

University of Groningen

Lagrangian modeling and control of DC-to-DC converters

Scherpen, Jacquélien M.A.; Klaassens, J. Ben; Ballini, Luca

Published in:
 Proceedings of the INTELEC'99

IMPORTANT NOTE: You are advised to consult the publisher's version (publisher's PDF) if you wish to cite from it. Please check the document version below.

Document Version
 Publisher's PDF, also known as Version of record

Publication date:
 1999

[Link to publication in University of Groningen/UMCG research database](#)

Citation for published version (APA):

Scherpen, J. M. A., Klaassens, J. B., & Ballini, L. (1999). Lagrangian modeling and control of DC-to-DC converters. In *Proceedings of the INTELEC'99* University of Groningen, Research Institute of Technology and Management.

Copyright

Other than for strictly personal use, it is not permitted to download or to forward/distribute the text or part of it without the consent of the author(s) and/or copyright holder(s), unless the work is under an open content license (like Creative Commons).

The publication may also be distributed here under the terms of Article 25fa of the Dutch Copyright Act, indicated by the "Taverne" license. More information can be found on the University of Groningen website: <https://www.rug.nl/library/open-access/self-archiving-pure/taverne-amendment>.

Take-down policy

If you believe that this document breaches copyright please contact us providing details, and we will remove access to the work immediately and investigate your claim.

Downloaded from the University of Groningen/UMCG research database (Pure): <http://www.rug.nl/research/portal>. For technical reasons the number of authors shown on this cover page is limited to 10 maximum.

Lagrangian modeling and control of DC-to-DC converters

Jacquélien M.A. Scherpen[§], J. Ben Klaassens[§], Luca Ballini^{§§*}

[§] Fac. ITS, Dept. of Electrical Eng., Delft University of Technology,
P.O. Box 5031, 2600 GA Delft, The Netherlands.
E-mail: J.M.A.Scherpen@its.tudelft.nl / J.B.Klaassens@its.tudelft.nl
Phone: +31-15-278 5768, +31-15-278 2928, Fax: +31-15-278 6679

^{§§} Fac. of Eng., Dept. Electronica, Computer Science and Systems,
University of Bologna, Viale Risorgimento 2, 40136 Bologna, Italy
E-mail: lballini@krenet.it

Abstract - In this paper a method is presented to build an Euler Lagrange model for switching electrical networks in a structured general way, which is also applicable to ideal electrical circuits without switches. The switches make the dynamic models nonlinear. For using the Lagrangian structure for controller design, a preliminary study of the zero-dynamics of such switching network is presented. A case study, where a passivity based controller has been applied, is given for the Ćuk converter.

I. INTRODUCTION

DC-to-DC power converters play a primary role in modern power systems for satellites, non-civilian, industrial and consumer electronic applications. Optimization of converter design is an important issue. Therefore a thorough understanding of the converter as a system is required and one must be able to analyze converter behavior like stability and transient response. Power converters employ pulse modulation for controlling the duty cycle. The pulse modulation process presents significant difficulties in analyzing the behavior of these converters. Approximations in system modeling are usually required. State-space averaging has been demonstrated to be an effective method for analysis.

The feedback regulation of DC-to-DC power supplies is, broadly speaking, accomplished through either pulse-width-modulation (PWM) feedback strategies, or by inducing an appropriate stabilizing sliding regime ([17], [11]). In the context of PWM feedback policies, modeling and regulation of switched DC-to-DC power converters was initiated by the pioneering work of Middlebrook and Ćuk ([9]) in the mid seventies. The average PWM model could be justified from a purely mathematical viewpoint, without regarding their possible physical significance or derived from the energy property of

the switched electrical circuit. In the latter we have the advantage of exploiting the physical properties during the feedback controller design stage. In particular, we would like to apply the *passivity-based* approach in the feedback duty ratio synthesis problem, i.e., based on the energy of a system we design a controller, see e.g. [13, 10] and therefore we like to work with Euler Lagrange models. Sira-Ramirez *et al.* demonstrate ([13]) for the 'boost', 'buck', 'buck-boost' converters on a case by case basis that idealized mathematically motivated models actually correspond to systems derivable from classical Euler-Lagrange (EL) dynamics considerations. The approach consists in establishing a suitable set of average *EL parameters* modulated by the duty ratio function. Here we develop a procedure that results in the EL parameters of a general switching electrical network structure, where we assume switches to be ON or OFF, and where the EL parameters are extended with constraint equations stemming from Kirchhoff's current laws.

Due to a possible non-minimum phase nature of the average output voltage variable, a *direct* application of the passivity-based design method, aimed primarily at output-voltage regulation, may lead to an unstable dynamical feedback controller. For this reason, an *indirect* approach, consisting of output-voltage regulation through stabilization of one of the other dynamical elements is undertaken. A study of the zero-dynamics is thus necessary, and here we present some preliminary results on this matter. Indirect controller design for a non-minimum phase system has been justified, for nonlinear system in the work of Benvenuti *et al.* ([1]).

In Section II we present the general procedure to develop an EL model for switching and non-switching electrical networks. Then, in Section III we give some preliminary results on general statements about the stability of the zero-dynamics, corresponding to the (non)-minimum phase behavior of the output. Section IV treats the development of a passivity based controller for the Ćuk converter. In Section V the simulations with the Ćuk converter are presented. Finally, in Section VI we end with the conclusions.

* Research performed within the Erasmus exchange program

II. EULER-LAGRANGE MODELING OF (SWITCHING) NETWORKS

The EL dynamics of an electric circuit, containing no magnetic coupling between its different branches, is classically characterized by the following set of nonlinear differential equations

$$\frac{d}{dt} \left(\frac{\partial \mathcal{L}}{\partial \dot{q}} \right) - \frac{\partial \mathcal{L}}{\partial q} = -\frac{\partial \mathcal{D}}{\partial \dot{q}} + \mathcal{F}_q \quad (1)$$

where \dot{q} is the vector of flowing current and q represent their time integrals, or *electric charge*. The vector of electric charge constitutes the *generalized coordinates* describing the circuit. This vector is assumed to have n components, represented by q_1, \dots, q_n . It is well-known that the scalar function \mathcal{L} is the *Lagrangian* of the system, defined as the difference between the *magnetic co-energy* of the circuit, denoted by $\mathcal{T}(q, \dot{q})$, and the *electric field energy* of the circuit, denoted by $\mathcal{V}(q)$, i.e.

$$\mathcal{L}(q, \dot{q}) = \mathcal{T}(q, \dot{q}) - \mathcal{V}(q) \quad (2)$$

The function $\mathcal{D}(\dot{q})$ is the *Rayleigh dissipation cofunction* of the system. The vector $\mathcal{F}_q = (\mathcal{F}_{q_1}, \dots, \mathcal{F}_{q_n})$ represents the ordered components of the set of *generalized forcing functions*, or voltage sources, associated with each generalized coordinate.

EL circuits are thus generally represented by the set of equation

$$\frac{d}{dt} \left(\frac{\partial \mathcal{T}}{\partial \dot{q}} \right) - \frac{\partial \mathcal{T}}{\partial q} + \frac{\partial \mathcal{V}}{\partial q} = -\frac{\partial \mathcal{D}}{\partial \dot{q}} + \mathcal{F}_q. \quad (3)$$

Following ([10]), we refer to the set of functions $(\mathcal{T}, \mathcal{V}, \mathcal{D}, \mathcal{F}_q)$ as the *EL parameters* of the circuits, and simply express a circuit Σ by means of the ordered quadruple:

$$\Sigma = (\mathcal{T}, \mathcal{V}, \mathcal{D}, \mathcal{F}_q). \quad (4)$$

We are interested in a general method for dynamic modeling of electrical networks, with or without switches. We consider ideal physical elements, and want to follow the above mentioned Lagrangian framework, so that the physics can be easily used for control purposes. However, actually the Euler-Lagrange (EL) equations are a balance of generalized forces, or, efforts, which in the electrical domain is given by the voltages, and involves both generalized position and generalized velocity coordinates for each separate physical element. In the electrical domain that means that we attach to each separate element (inductor and capacitor) *two* state-variables, namely a charge and a current. Clearly this does not correspond to the physical intuition, but it can be viewed as if for the inductor the charge is an *intermediate help* variable, and for the condensator the current is. In order to involve also the Kirchhoff current laws, we need to consider the constraint form of the EL equations, see e.g. [14], given by,

$$\begin{aligned} \frac{d}{dt} \left(\frac{\partial \mathcal{L}}{\partial \dot{q}} \right) - \frac{\partial \mathcal{L}}{\partial q} &= -\frac{\partial \mathcal{D}}{\partial \dot{q}} + A(q)\lambda + \mathcal{F}_q \\ A(q)^T \dot{q} &= 0 \end{aligned} \quad (5)$$

which then finally results in the removal of these intermediate help variables. This procedure can be performed for electrical networks with linear inductive and capacitive elements and with or without ideal switches. The switches can be naturally involved in the constraints that follow from Kirchhoff's current laws. If we denote by the scalar u the switch position, which is assumed to take values on a discrete set of the form $\{0, 1\}$. The complete procedure is as follows:

Procedure:

1. Give all n dynamic elements in the network two coordinates, namely a charge and a current coordinate, q_i , and \dot{q}_i , $i = 1 \dots n$.
2. Determine the corresponding energy for all ideal elements, i.e., the magnetic co-energy for the inductive elements, denoted by $\mathcal{T}(q, \dot{q})$, and the electric field energy for the capacitive elements, denoted by $\mathcal{V}(q)$. In case of a switching network, this step does *not* involve the position of the switch.
3. Determine the Rayleigh dissipation energy, denoted by $\mathcal{D}(\dot{q})$, for the resistive elements, which may involve the switch position u , and the use of a Kirchhoff current law for determining the current through the resistive element in terms of the dynamic elements as given in step 1.
4. Determine the generalized forcing functions \mathcal{F}_q given by the voltage sources, possibly depending on the switch position.
5. Give the constraint equations that are determined by Kirchhoff's currents laws, that do not include the laws of step 3, and thus only involve the currents through the dynamic elements. If there are no constraint equations for this step, then put $A(q) = 0$.
6. Plug the information of the previous steps in the constraint form of the EL equations (5) and determine a state space model by choosing the currents corresponding with the inductive elements, and either the charge or the voltage corresponding with the capacitive elements, as state variables. \square

In the following we present two examples to illustrate the above method, a simple LC-circuit with an odd number of states, and a Čuk converter circuit with an ideal switch. Both of these examples use the constraint Euler-Lagrange equations (5). The Čuk converter serves as a case study further in the paper. However, the above procedure also applies to the unconstrained case, i.e., where $A(q) = 0$, like in the examples of the buck, boost and buck-boost converter circuits, [13], where the EL models of these systems have been obtained on a case by case basis.

Example 1: LC-circuit of Figure 1.

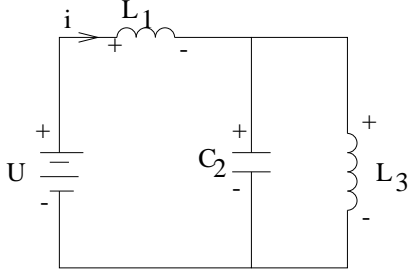

Figure 1: LC circuit

This example is taken from Example 4.2.1. of [14], and is meant to show the potential of this method, even if the number of dynamic elements is not even. At first sight the EL equations may demand an even number, but due to the above procedure where each dynamic element has two coordinates, this is not necessary.

(Intermediate) state variables: $q_i, \dot{q}_i, i = L_1, C_2, L_3$

Lagrangian: $\mathcal{L} = \frac{1}{2}L_1\dot{q}_{L_1}^2 + \frac{1}{2}L_3\dot{q}_{L_3}^2 - \frac{1}{2C_2}q_{C_2}^2$

Kirchhoff: $\dot{q}_{L_1} - \dot{q}_{L_3} - \dot{q}_{C_2} = 0$

with $q = (q_{L_1}, q_{C_2}, q_{L_3})^T$ we obtain from the equations (5) with $A(q)^T = (1, -1, -1)$

$$\begin{aligned} L_1\ddot{q}_{L_1} &= \lambda + V \\ \frac{1}{C_2}q_{C_2} &= -\lambda \\ L_3\ddot{q}_{L_3} &= -\lambda \\ 0 &= \dot{q}_{L_1} - \dot{q}_{L_3} - \dot{q}_{C_2} \end{aligned}$$

which results in the dynamical equations corresponding to (4.19) in [14], with $(x_1, x_2, x_3) = (\dot{q}_{L_1}, \frac{1}{C_2}q_{C_2}, \dot{q}_{L_3})$

$$\begin{aligned} \dot{x}_1 &= -\frac{1}{L_1}x_2 + V \\ \dot{x}_2 &= \frac{1}{C_2}(x_1 - x_3) \\ \dot{x}_3 &= \frac{1}{L_3}x_2 \end{aligned} \quad \square$$

Example 2: Ćuk converter of Figure 2.

This example illustrates the potential of the proposed procedure for switching networks, and serves as a case study throughout the paper.

(Intermediate) state variables: $q_i, \dot{q}_i, i = L_1, C_2, L_3, C_4$

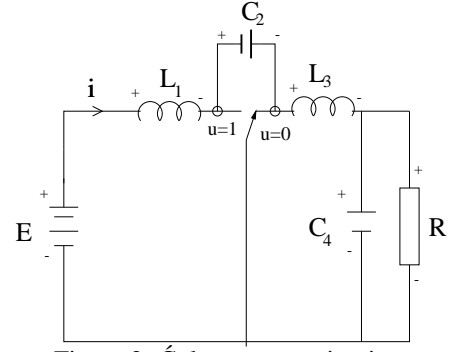

Figure 2: Ćuk converter circuit

Magnetic co-energy: $T(\dot{q}_L) = \frac{1}{2}L_1\dot{q}_{L_1}^2 + \frac{1}{2}L_3\dot{q}_{L_3}^2$

Electric field energy: $\mathcal{V}(q_C) = \frac{1}{2C_2}q_{C_2}^2 + \frac{1}{2C_4}q_{C_4}^2$

Rayleigh dissipation: $\mathcal{D}(\dot{q}_{L_3}, \dot{q}_{C_4}) = \frac{1}{2}R(\dot{q}_{L_3} - \dot{q}_{C_4})^2$

External forces: $\mathcal{F}_{q_{L_1}} = E, \mathcal{F}_{q_{C_2}} = \mathcal{F}_{q_{L_3}} = \mathcal{F}_{q_{C_4}} = 0$

Kirchhoff constraint: $\dot{q}_{C_2} - u\dot{q}_{L_3} - (1-u)\dot{q}_{L_1} = 0$

And thus $A(q)^T = (-(1-u), 1, -u, 0)$. Plugging this into the equations (5) yields for the Ćuk converter:

$$\begin{aligned} L_1\dot{q}_{L_1} &= -(1-u)\lambda + E \\ \frac{1}{C_2}q_{C_2} &= \lambda \\ L_3\ddot{q}_{L_3} &= -R(\dot{q}_{L_3} - \dot{q}_{C_4}) - u\lambda \\ \frac{1}{C_4}q_{C_4} &= R(\dot{q}_{L_3} - \dot{q}_{C_4}) \\ 0 &= \dot{q}_{C_2} - u\dot{q}_{L_3} - (1-u)\dot{q}_{L_1} \end{aligned}$$

which results in the state equations for $(x_1, x_2, x_3, x_4) = (\dot{q}_{L_1}, \frac{1}{C_2}q_{C_2}, \dot{q}_{L_3}, \frac{1}{C_4}q_{C_4})$:

$$\begin{aligned} \dot{x}_1 &= -(1-u)\frac{1}{L_1}x_2 + \frac{E}{L_1} \\ \dot{x}_2 &= (1-u)\frac{1}{C_2}x_1 + u\frac{1}{C_2}x_3 \\ \dot{x}_3 &= -u\frac{1}{L_3}x_2 - \frac{1}{L_3}x_4 \\ \dot{x}_4 &= \frac{1}{C_4}x_3 - \frac{1}{RC_4}x_4 \end{aligned} \quad (6)$$

This is the model with the discrete values for the switch, but as we will see next, is also closely related to the PWM model. \square

A PWM policy regulating the switch position function u may be specified as follows:

$$u(t) = \begin{cases} 1, & \text{for } t_k \leq t < t_k + D(t_k)T \\ 0, & \text{for } t_k + D(t_k)T \leq t < t_k + T \end{cases} \quad (7)$$

$$t_{k+1} = t_k + T; \quad k = 0, 1, \dots$$

where t_k represent a sampling instant; the parameter T is the fixed sampling period; the sampled value of the state vector $x(t)$

of the converter are denoted by $x(t_k)$. The function $D(\cdot)$ is the *duty ratio function*, acting as an external control input to the average PWM model of the converter [12]. The value of the duty ratio function $D(t_k)$ determines at every sampling instant t_k the width of the upcoming ON pulse as $D(t_k)T$ (during this period the switch is fixed at the position represented by $u = 1$). Now, the duty ratio function $D(\cdot)$ is evidently a function limited to take real values on the open interval $]0,1[$.

For networks with a switch, note that, according to the PWM switching policy (7), at every sampling interval of period T , the Kirchhoff constraint $A(q)^T \dot{q} = 0$ for $u = 1$ is valid over only a fraction of the sampling period given by $D(t_k)$, while the constraint for $u = 0$ is valid over only a fraction of the sampling period equal to $(1 - D(t_k))$. One possible way to handle this, is to consider an average value of the Kirchhoff constraint and thus to propose the set of EL parameters with the constraint dependent on the duty cycle, as in the original procedure it is dependent on the discrete values of the switch. Note that if we would take $D = 1$ or 0 , one recovers, respectively, the Kirchhoff constraint for the two switch positions. Indeed, such a *consistency* condition is verified by noting that

$$\begin{aligned} A(q)^T \dot{q} |_{D=1} &= 0, \\ A(q)^T \dot{q} |_{D=0} &= 0. \end{aligned} \quad (8)$$

We note that the Lagrangian function associated with the above defined average EL parameters is actually *invariant* with respect to the switch position function.

Example 2 (continued)

The PWM model for the Čuk converter is given by the dynamic equations as in (6), where the state variable x is replaced by the average state z , i.e., z_1 and z_3 represent the average inductor currents, and z_2 and z_4 the average capacitor voltages, and where the discrete signal u is replaced by the duty cycle D that takes values in the open interval $]0,1[$. \square

The presented Euler-Lagrange modeling technique for (switching) networks results in the same dynamical models as when the Hamiltonian framework is used, e.g. [7, 3], provided that the same level of ideal physics is assumed. However, the Hamiltonian framework does not introduce the “semi”-physical intermediate help-variables. Nevertheless, we do think that the above framework is an easy, general, and straightforward way to obtain the dynamic models of electrical networks, where the interconnection between the elements, given by the Kirchhoff laws, corresponds to the straightforward knowledge of the electrical engineer. It gives us the opportunity to apply the well-known passivity based control techniques, as presented in [13] for the buck, boost and buck-boost converter, but this time for more general electrical network structures.

III. ZERO-DYNAMICS

In the sequel, we continue with the dynamic PWM model of the converter structures, as can be obtained from the previous section, where we now denote the averaged state space variables by z , and the duty cycle by D . The design of passivity based control for the buck, boost, and buck-boost converter can be found in [13], whereas further analysis of the closed loop system is explored in some follow-up work, e.g. [15, 16]. Since we have given a general procedure to build an Euler-Lagrange model for switching networks, we can also generally apply the passivity based control design technique. However, one issue that remains is the choice of the average state variable to be stabilized to a certain value, in order to, possibly indirectly, regulate our average output toward a desired equilibrium value. For the boost and buck-boost converters, it was shown in [13] that the average output voltage could not be directly controlled, due to the unstable zero-dynamics (i.e., for linear systems this corresponds to zeros in the right half plane, or in other words, undesirable non-minimum phase behavior), and therefore, had to be indirectly controlled via the average input-current, which exposed stable zero-dynamics.

In general, we can not say much about the stability or instability of the zero-dynamics of the separate elements of switching networks, since we are not able to give general descriptions of the zero-dynamics. However, when we consider converter structures with one switch, a resistive element over the output capacitor, a constant voltage source that applies to an inductive element, and exclude the forcing function to depend on the switch position (like for the buck converter), then we can at least give one element of the zero-dynamics.

The description of the dynamics as described in words above is given by the following more compact matrix representation

$$\mathcal{M}\dot{z} + D\mathcal{J}_1 z + \mathcal{J}_2 z + \mathcal{R}z = \mathcal{E} \quad (9)$$

where \mathcal{M} is invertible, and where $\mathcal{J}_i = -\mathcal{J}_i^T$ and its elements are given by $\{-1, 0, 1\}$, for $i = 1, 2$.

Example 2 (continued)

For the Čuk converter of Example 2 we have

$$\mathcal{M} = \begin{pmatrix} L_1 & 0 & 0 & 0 \\ 0 & C_2 & 0 & 0 \\ 0 & 0 & L_3 & 0 \\ 0 & 0 & 0 & C_4 \end{pmatrix}; \quad \mathcal{J}_1 = \begin{pmatrix} 0 & -1 & 0 & 0 \\ 1 & 0 & -1 & 0 \\ 0 & 1 & 0 & 0 \\ 0 & 0 & 0 & 0 \end{pmatrix};$$

$$\mathcal{R} = \begin{pmatrix} 0 & 0 & 0 & 0 \\ 0 & 0 & 0 & 0 \\ 0 & 0 & 0 & 0 \\ 0 & 0 & 0 & 1/R \end{pmatrix}; \quad \mathcal{J}_2 = \begin{pmatrix} 0 & 1 & 0 & 0 \\ -1 & 0 & 0 & 0 \\ 0 & 0 & 0 & 1 \\ 0 & 0 & -1 & 0 \end{pmatrix};$$

$$\mathcal{E} = \begin{pmatrix} E \\ 0 \\ 0 \\ 0 \end{pmatrix}.$$

□

For the converter structures we consider here, we can bring the system in normal form (see e.g., [4]) for the output y given by the state z_i , which has relative degree r_i , then we obtain the new coordinates, $\xi = (\xi_1, \dots, \xi_{r_i})^T$, and $\eta = (\eta_{r_i+1}, \dots, \eta_n)^T$, with $(\xi, \eta) = \phi(z)$, and $\phi_1 = y, \dots, \phi_{r_i} = y^{(r_i)}$. For the η coordinates, that are related to the state of the zero-dynamics we obtain

$$\frac{\partial \phi_i}{\partial z}(z) \mathcal{M}^{-1} \mathcal{J}_1 z = 0, \quad i = r_i + 1, \dots, n.$$

This implies that at least the total energy, given by

$$\phi_{r_i+1}(z) = \frac{1}{2} z^T \mathcal{M} z \quad (10)$$

is part of the zero-dynamics. If we drop the assumption that the generalizing forces are independent of the switch, we can still do the above analysis, but then we have to add to the total energy of (10) an additional term which depends on the voltage source.

IV. PASSIVITY BASED CONTROL FOR THE ČUK CONVERTER

In the sequel we will continue with the passivity based controller design for the Čuk converter of Example 2 as a case study. It is immediately obtained that the equilibrium values for a constant duty ratio function $D(t) = D_c$ is for the average currents, denoted by I_{1_d}, I_{2_d} , and the average voltage, denoted by V_{1_d}, V_{2_d} , are given by

$$I_{1_d} = \frac{E}{R} \left(\frac{D_c}{1-D_c} \right)^2; \quad V_{1_d} = \frac{E}{1-D_c};$$

$$I_{2_d} = -\frac{D_c}{1-D_c} \frac{E}{R}; \quad V_{2_d} = -\frac{D_c}{1-D_c} E. \quad (11)$$

Note that for D_c in the open interval $]0, 1[$, results in $V_{2_d} < 0$. Henceforth, given a desired equilibrium value V_{2_d} for the output voltage, which correspond to a constant value of the duty ratio function $D_c = V_{2_d}/(V_{2_d} - E)$, the *unique* corresponding equilibrium values for the average voltage and currents are

$$I_{1_d} = \frac{V_{2_d}^2}{RE}; \quad I_{2_d} = \frac{V_{2_d}}{R}; \quad V_{1_d} = E - V_{2_d}. \quad (12)$$

This means that if we desire to regulate z_4 toward an equilibrium value V_{2_d} which is known to correspond to a steady state value D_c of the duty ratio function D , then such a regulation can be *indirectly* accomplished by stabilizing one of the other average variables toward the corresponding equilibrium values computed in (12).

If we consider the average output voltage z_4 as the output, we see that $r_4 = 2$, and thus that

$$\xi_1 := \phi_1(z) = z_4$$

$$\xi_2 := \phi_2(z) = \dot{z}_4 = \frac{1}{C_4} z_3 - \frac{1}{RC_4} z_4$$

and that the state of the zero-dynamics is going to be determined by

$$\eta_1 := \phi_3(z) = L_1 z_1 + L_3 z_3$$

$$\eta_2 := \phi_4(z) = \frac{1}{2} z_1^2 L_1 + \frac{1}{2} z_2^2 C_2 + \frac{1}{2} z_3^2 L_3$$

We now use Mathematica 3.0 for calculating $z = \phi^{-1}(\xi, \eta)$, and we form the zero-dynamics by giving z_4 its desired value V_{2_d} , i.e., then $\xi_1 = V_{2_d}$, $\xi_2 = 0$, and then we consider the dynamics of η , see [4]. In order to determine whether or not the zero-dynamics are stable, we linearize the zero-dynamics at the equilibrium point η^0 , that corresponds to (12).

In order to be able to numerically compute the eigenvalues, in order to determine the stability, we need to fill in some values for the parameters. Mathematica is not yet able to do this symbolically for the expressions we have here. In the sequel, when the stability of the zero-dynamics has to be computed, we use for the parameters the following (real-life) values: $E = 100 \text{ V}$, $R = 40 \text{ } \Omega$, $L_1 = L_3 = 600 \text{ } \mu\text{H}$, $C_2 = C_4 = 10 \text{ } \mu\text{F}$. In the case of the zero-dynamics of z_4 this yields for the linearization the eigenvalues $(625 - 9107.29i, 625 + 9107.29i)$ with real part in the right half plane. Thus the zero-dynamics are unstable, and we can conclude that directly controlling z_4 to its desired value is infeasible, due to non-minimum phase behavior.

Consider now the output of the circuit to be represented by the average output current z_3 (i.e., $y = z_3$). In this case we would perform an indirect control of the output voltage z_4 by controlling the output current z_3 . The relative degree $r_3 = 1$. In order to find the zero-dynamics we proceed as along the same lines as above, i.e.,

$$\xi := \phi_1(z) = z_3$$

and then we find $\phi_2(z), \phi_3(z), \phi_4(z)$ by taking

$$\eta_1 := \phi_2(z) = \frac{1}{2} z_1^2 L_1 + \frac{1}{2} z_2^2 C_2 + \frac{1}{2} z_3^2 L_3$$

$$\eta_2 := \phi_3(z) = L_1 z_1 + L_3 z_3 \quad (13)$$

$$\eta_3 := \phi_4(z) = z_4.$$

Again we perform the calculation of the inverse transformation $\phi^{-1}(\xi, \eta)$ with the help of Mathematica 3.0, and we find the

zero-dynamics as described above, where now $z_3 = I_{1d}$. The numerical results of the linearization yield in this case three eigenvalues $(-2500, 625 - 9107.29i, 625 + 9107.29i)$; since the two complex conjugates have the real part greater than zero we conclude that the controller is, unfortunately, not feasible due to its lack of stability.

Consider now the output of the system to be represented by the average input voltage z_2 . In this case we would perform an indirect control of the output voltage z_4 by controlling the input voltage z_2 . The relative degree of z_2 is $r_2 = 1$. As above, we now have

$$\xi := \phi_1(z) = z_2$$

and then we complete the transformation by taking η_1, η_2, η_3 as in (13). Again the calculation of the inverse transformation $z = \phi^{-1}(\xi, \eta)$ has been performed with the help of Mathematica 3.0. The zero-dynamics are then given by putting $z_2 = V_{1d}$, and linearizing these dynamics yields eigenvalues with a real part in the right half plane, i.e., $(-15311.6, 6405.8 - 17938.7i, 6405.8 + 17938.7i)$. Hence, we conclude that controlling z_4 via z_2 is also infeasible.

Our last opportunity for indirectly controlling the output voltage z_4 is given by controlling the average input current z_1 , which also has relative degree $r_1 = 1$. Hence, as above,

$$\xi := \phi_1(z) = z_1$$

and we complete the transformation by taking η_1, η_2, η_3 as in equation (13). Going through the calculations with $z_1 = I_{1d}$, we obtain for the linearized zero-dynamics the three eigenvalues $(-1668.99, -1040.5 + 15766.1i, -1040.5 - 15766.1i)$. Now all of them have the real part in the left half plane. Hence, we conclude that, at least for the chosen values of the parameters, controlling z_4 indirectly via z_1 is feasible. Since the expression is too complicated we are not able to analyze the behavior of the eigenvalues depending on the parameters analytically, but we have seen that for varying values of the parameters the order and the sign of the eigenvalues remain the same. Hence, from the above analysis we may conclude that we can indirectly control the output voltage by controlling the input current.

We now provide the only feasible regulation based on an *indirect* output capacitor voltage control, achievable through the regulation of the input current. Suppose it is desired to regulate z_1 towards a constant value $z_{1d} = I_{1d}$. Corresponding to this objective for the input voltage z_1 , the required input voltage, output voltage and output current may be represented by the functions $z_{2d}(t)$, $z_{3d}(t)$ and $z_{4d}(t)$, to be determined later. Now we follow the procedures as given in [10], and by the same thread as in [13] we obtain the following controller that preserves pas-

sivity of the closed loop system:

$$\begin{aligned} \dot{z}_{2d} &= -\frac{1}{C_2} \left(\left(1 - \frac{E + R_1(z_1 - I_{1d})}{z_{2d}}\right)(I_{1d} - z_{3d}) - I_{1d} \right. \\ &\quad \left. - R_2(z_2 - z_{2d}) \right) \\ \dot{z}_{3d} &= -\frac{1}{L_3} \left(\left(1 - \frac{E + R_1(z_1 - I_{1d})}{z_{2d}}\right)z_{2d} + z_{4d} \right. \\ &\quad \left. - R_3(z_3 - z_{3d}) \right) \\ \dot{z}_{4d} &= -\frac{1}{C_4} \left(\frac{1}{R}z_{4d} - z_{3d} \right) \\ &\quad z_{2d}(0) > 0 \end{aligned} \tag{14}$$

$$D = 1 - \frac{E + R_1(z_1 - I_{1d})}{z_{2d}}$$

where $R_1, R_2, R_3 > 0$ are design parameters that inject the damping that is required for asymptotic stability. For further analysis, we refer to related considerations and remarks as given in [13]. We only present the scheme of Fig. 3 which is the implementation scheme based on philosophies that can be found in [5, 6].

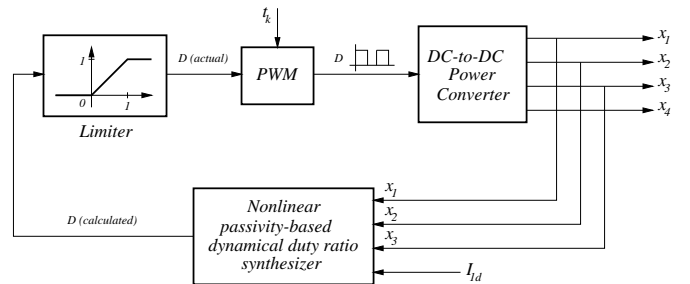

Figure 3: PWM feedback control scheme for indirect, passivity-based, output voltage regulation for Ćuk converter.

V. SIMULATION RESULTS

Simulation are performed in order to test the effectiveness and robustness of the proposed feedback controller. First of all we set an ideal voltage source $E = 100 V$. Resistors, capacitors, inductors and the transistor are supposed to be also ideal and as before, their values are taken to be the following typical values: $R = 40 \Omega$, $L_1 = L_2 = 600 \mu H$, $C_1 = C_2 = 10 \mu F$. For the damping parameters we choose the values $R_1 = 1$, $R_2 = 1$, $R_3 = 1$. For the switch implementation we had to consider both the following cases

- (i) Ideal switch
- (ii) Actual switch (one position switch plus diode)

In fact we would always like to use the actual switch but this however implies two nonlinear models for the plant (one when the transistor is ON and the other when the transistor is OFF) and for small values of the desired output voltage we get numerical problems.

For the use of the ideal switch, we have a numerically efficient procedure that uses the fact that for both switch positions we have a linear model, i.e.,

$$\dot{x}(t) = Ax(t) + B$$

and we can easily find the solution

$$\begin{aligned} x(t + \Delta t) &= e^{A\Delta t}x(t) + \int_t^{t+\Delta t} e^{A(t+\Delta t-s)}Bs ds \\ &= e^{A\Delta t}x(t) - A^{-1}B + A^{-1}e^{A\Delta t}B. \end{aligned}$$

for A invertible, which is the case here. It is also necessary to charge the electric network before applying the controller otherwise we run into numerical problems. Since our calculations are only valid near the equilibrium values, this does not seem very restrictive.

When we use the real switch, for the diode we use the exponential relation

$$I = I_R(e^{\frac{V}{k}} - 1)$$

where the reverse current is $I_R = 1 \text{ mA}$ and $k = 0.1086$ i.e. the forward current is $I_F = 10 \text{ A}$ when the forward voltage is $V_F = 1 \text{ V}$. These are typical values for a power diode. The sampling frequency for the PWM policy is set at 230 kHz , which gave the best trade-off between accuracy and simulation time. To avoid the use of low-pass filters, instead of using the averaged state variables z_1 , z_2 and z_3 for feedback on the duty ratio synthesizer, we use as it is customarily done, the actual PWM controlled state x_1 , x_2 and x_3 in the controller equations. The desired ideal average input inductor current is calculated by the equation in (12). We have set $V_{2_d} = -200 \text{ V}$ and this correspond to an ideal average input current $I_{1_d} = 10 \text{ A}$, with a steady-state duty ratio of $D = 0.667$; from the equations in (12) we calculate also the other ideal average values $I_{2_d} = -5 \text{ A}$ and $V_{1_d} = 300 \text{ V}$. Figure 4 shows the closed-loop state trajectories as well as the duty ratio function. As can be seen from the simulation, the proposed feedback controller (14) achieves the desired indirect stabilization of the output voltage around the desired equilibrium value. The average steady-state errors, with respect to the equilibrium values, is approximately 2.8% in the input current, 0.2% in the input voltage, 4.8% in the output current and about 0% in the output voltage. The ideal duty ratio is also achieved within 0% error.

In applications these systems are typically subject to external disturbances (see e.g., [15], [16]). For instance, the regulated voltage is perturbed by fluctuations in the external voltage source. In Figure 5 a stochastic perturbation signal has been

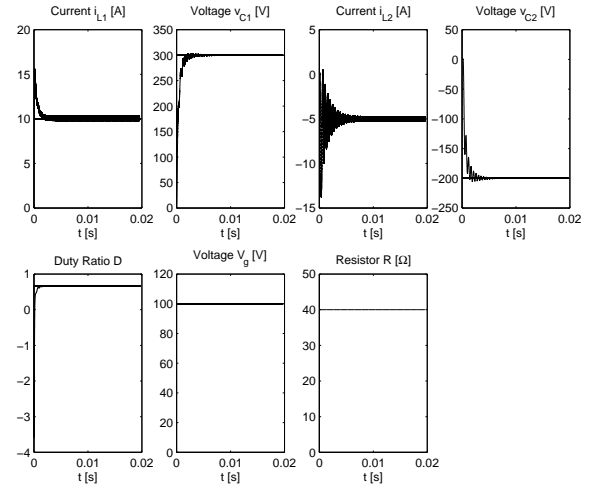

Figure 4: Simulation result for performance evaluation of the indirect PWM controller in a Ćuk converter with an ideal source voltage E .

added to the external voltage source starting from an initially uncharged system. The peak-to-peak magnitude of this noise is chosen to be approximately 20% of the value of E . The aver-

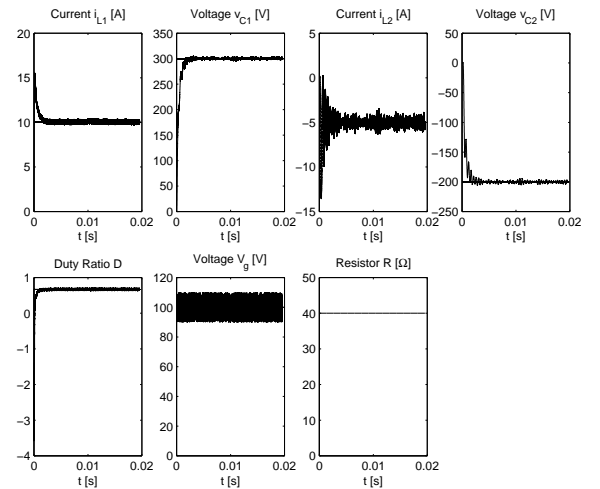

Figure 5: Simulation result for performance evaluation of the indirect PWM controller in a Ćuk converter with a perturbed source voltage E .

age steady-state errors, with respect to the equilibrium values, is now approximately 4% in the input current, 1.4% in the input voltage, 27% in the output current and 2.6% in the output voltage. The ideal duty ratio is achieved within less than 6% error. The controller performance hence exhibits a high degree of robustness with respect to the external stochastic perturbation.

Unknown load resistance variation generally affects the behavior of the closed-loop performance of the controlled converter. Simulations, shown in Fig. 6, were performed to depict the sen-

sitivity of the system currents, voltages and duty ratio with respect to abrupt, but temporary, unmodeled changes in the load resistance R . A sudden change in the load resistance was set to

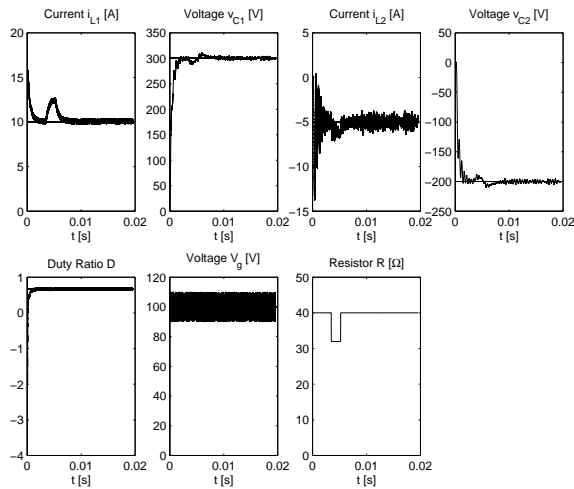

Figure 6: Robustness evaluation of the indirect PWM controller in a Ćuk converter with a perturbed source voltage and an abrupt change in the load resistor R .

20% of its nominal value. As can be seen from the figure, the controller rapidly manages to restore the desired steady state conditions immediately after the load perturbation disappears. The state variable most affected by such a perturbation is the input current. Conversely, as can be expected, the duty ratio function is barely affected by such sudden load change.

VI. CONCLUSION

A method has been presented to build in a structured way an Euler Lagrange model for switching electrical networks, which is also applicable to ideal electrical circuits without switches. The switches make the models nonlinear, and for using the physical structure as exposed by the EL model, we have made a preliminary study of the zero-dynamics of such switching network. A case study, where a passivity based controller has been applied, is given for the Ćuk converter.

The presented method now has the advantage that we have a general modeling technique for switching networks such that we immediately can apply some well-known nonlinear controller techniques that are based on the physics of the system, namely the passivity based control technique.

The method presented here can also be performed for Hamiltonian models, which is a recent topic of study in e.g., [3, 7], and can be argued to be better physically motivated, since no intermediate physical help variables are needed. However, in some cases it might be helpful to build Euler Lagrange models, since

it is sometimes easier, and since we then can apply well-known passivity based control techniques.

Further research is recommended in the development of an adaptive modification of the controller because one of the useful properties of the passivity-based controllers is that they easily can be modified to account for parametric uncertainty in the system dynamics. Furthermore, future research includes the involvement of more non-ideal physical effects, a more general statement about the non-minimum phase behavior, and the influence of the different topologies that are given in the power electronics literature.

Acknowledgments

We like to thank Jacob van der Woude for his help with the Matlab implementations. We also like to thank Romeo Ortega and Gerardo Escobar for the discussions on the zero-dynamics and the Ćuk converter.

REFERENCES

- [1] L. Benvenuti, M.D. di Benedetto and J.W. Grizzle, "Approximate output tracking for nonlinear non-minimum phase system with applications to flight control", *Michigan Control Group Report CGR-92-20*, University of Michigan, Ann Arbor MI (1992).
- [2] E. van Dijk, H.J.N. Spruijt, D.M. O'Sullivan, J.B. Klaassens, "PWM-Switch Modeling of DC-DC converters", *IEEE Trans. Pow. Elec.*, Vol. 10 (1995) 659–665.
- [3] G. Escobar, A.J. van der Schaft, R. Ortega, "A Hamiltonian viewpoint in the modeling of switching power converters", *Automatica*, Vol. 35 (1999) 445–452.
- [4] A. Isidori, *Nonlinear Control Systems*, Third Edition, Springer Verlag, London (1995).
- [5] J.G. Kassakian, M. Schlecht and G.C. Verghese, *Principles of power electronics*, Addison-Wesley, Reading, MA (1991).
- [6] H. Sira-Ramírez, P. Lischinsky-Arenas, "Dynamical discontinuous feedback control of nonlinear system", *IEEE Trans. Aut. Contr.* AC-35 (1990) 1373–1378.
- [7] B. Maschke, R. Ortega, A.J. van der Schaft, "Energy-based Lyapunov functions for forced Hamiltonian systems with dissipation", to appear in *IEEE Trans. Aut. Contr.*
- [8] E.R.W. Meerman, H.J.N. Spruijt, "PWM Converter Topologies", *Proc. Eur. Space Pow. Conf., Madrid, Spain* (Aug. 1988) 297–305.
- [9] R.M. Middlebrook, S. Ćuk, "A general unified approach to modeling switching converter power stages", *IEEE Power Electr. Spec. Conf. (PESC)* (1976) 18–34.
- [10] R. Ortega, A. Loría, R. Kelly and L. Praly, "On passivity-based output feedback global stabilization of Euler-Lagrange system", *Int. J. Robust Nonlinear Control*, 5, pp. 313–324, 1995.

- [11] A. Sabanovic, N. Sabanovic and K. Ohnishi, *Sliding modes in power converter and motion control system*, Int. J. Control, 57, pp. 1237–1259, 1993.
- [12] H. Sira-Ramírez, “A geometric approach to pulse-width-modulated control in nonlinear dynamical system”, *IEEE Trans. Aut. Contr.* AC-34 (1989) 184–187.
- [13] H. Sira-Ramirez, R.A. Perez-Moreno, R. Ortega, M. Garcia-Esteban, “Passivity-Based Controllers for the Stabilization of DC-to-DC Power Converters”, *Automatica*, Vol. 33, 4 (1997) 499–513.
- [14] A.J. van der Schaft, *\mathcal{L}_2 -gain and passivity techniques in nonlinear control*, Springer Verlag, Lecture Notes in Contr. & Inf. Sc. 218, 1996.
- [15] J.M.A. Scherpen, R. Ortega, “On nonlinear control of Euler-Lagrange system: Disturbance attenuation properties”, *System & Control Letters* 30, pp.49–56, 1997.
- [16] J.M.A. Scherpen, R. Ortega, G. Escobar, “On disturbance attenuation properties of control schemes for Euler-Lagrange systems: theoretical and experimental results”, *Proc. Eur. Contr. Conf. Brussels*, Vol. 6a, FR-A A6, 6pp., (July 1997).
- [17] V. Venkataramanan, A. Sabanovic and S. Čuk, *Sliding mode control of DC-to-DC converters*, Proc. IECON’85, pp. 251–258.