

University of Groningen

SAInt - A Simulation Tool for analyzing the Consequences of Natural Gas Supply Disruptions

Pambour, Kwabena Addo; Dijkema, Gerhard; Bolado-Lavin, Ricardo

Published in:
 Pipeline Technology Conference

IMPORTANT NOTE: You are advised to consult the publisher's version (publisher's PDF) if you wish to cite from it. Please check the document version below.

Document Version
 Publisher's PDF, also known as Version of record

Publication date:
 2016

[Link to publication in University of Groningen/UMCG research database](#)

Citation for published version (APA):
 Pambour, K. A., Dijkema, G., & Bolado-Lavin, R. (2016). SAIInt - A Simulation Tool for analyzing the Consequences of Natural Gas Supply Disruptions. In *Pipeline Technology Conference*

Copyright

Other than for strictly personal use, it is not permitted to download or to forward/distribute the text or part of it without the consent of the author(s) and/or copyright holder(s), unless the work is under an open content license (like Creative Commons).

The publication may also be distributed here under the terms of Article 25fa of the Dutch Copyright Act, indicated by the "Taverne" license. More information can be found on the University of Groningen website: <https://www.rug.nl/library/open-access/self-archiving-pure/taverne-amendment>.

Take-down policy

If you believe that this document breaches copyright please contact us providing details, and we will remove access to the work immediately and investigate your claim.

Downloaded from the University of Groningen/UMCG research database (Pure): <http://www.rug.nl/research/portal>. For technical reasons the number of authors shown on this cover page is limited to 10 maximum.



SAInt - A Simulation Tool for analyzing the Consequences of Natural Gas Supply Disruptions

Kwabena Addo Pambour^{a,*}, Ricardo Bolado-Lavin^b, Gerard P. J. Dijkema^a

^a University of Groningen, Energy and Sustainability Research Institute Groningen (ESRIG), Nijenborgh 4, 9747 AG Groningen, The Netherlands

^b European Commission, Joint Research Centre (JRC), Institute for Energy and Transport (IET), Westerduinweg 3, 1755 LE Petten, The Netherlands

Abstract

The interruption of gas supply to the EU through Ukraine in January 2009 has been the largest gas crises in the EU ever. This was the triggering event to develop and finally enact Regulation 994/2010 on security of gas supply, nowadays of mandatory implementation by EU Member States (MS). According to this Regulation, MS have to develop a Risk Assessment (RA), a Preventive Action Plan (PAP) and an Emergency Plan (EP), among other obligations. The development of a RA needs the identification of a number of scenarios, and the estimation of their probabilities and consequences. In this paper, we focus our effort on the correct estimation of consequences of potential scenarios. Given the complex and dynamic behavior of national or regional gas transport systems (GTS), this estimation can only be done with an adequate gas transport network simulation model. In previous work, a mathematical engine (SAInt) was developed for simulating hydraulic transients in GTS under isothermal conditions. Nevertheless, the actual resolution of transport equations is not sufficient to simulate the degrees of freedom of a network to react to a transient or, more severe, to a gas supply disruption. In this paper, we identify the different actions that the operator, market actors and authorities may adopt in the different steps of a gas crisis and the infrastructure elements used to implement those actions (production sites - PRO, underground gas storage facilities - UGS, liquefied natural gas regasification terminals - LNG, compressor stations - CS, cross border entry points - CBE, etc.). Furthermore, we identify the different possible control modes of each facility in the gas infrastructure

*corresponding author, Email: k.a.pambour@rug.nl, Web: <https://de.linkedin.com/in/kpambour>

and implement them in SAInt to further develop its capabilities as an integrated simulation tool to analyze gas supply disruptions. Finally, we apply SAInt on a real world instance.

Keywords: *natural gas crises, security of gas supply, gas supply disruption, transient hydraulic simulation*

1 Introduction

The interruption of the gas flows to the EU through Ukraine in January 2009 has been the largest gas crises in the EU ever. Russian gas exports through Ukraine were drastically reduced on January 6th, 2009, and completely interrupted the day after. Gas flows started again on January 20th and were completely restored only on January 22nd. This event triggered a deep analysis of EU vulnerability to gas disruptions led by the European Commission. The final result of this effort ended up with the enactment of Regulation 994/2010 [1] on security of gas supply. According to this Regulation, MS have to develop a Risk Assessment (RA), a Preventive Action Plan (PAP) and an Emergency Plan (EP), among other obligations. The target of the RA is to identify the scenarios that introduce most risk into the system (more likely to happen and more severe in consequences). Results of the RA are input to the PAP and the EP. The target of the PAP is to deploy measures to prevent the occurrence of scenarios that contribute most to the risk, or at least to make them less likely to happen. The target of the EP is to design strategies to mitigate the consequences of severe scenarios, should they happen.

The development of a RA needs the identification of a number of scenarios, and the estimation of their probabilities and consequences. Normally, consequences are given in terms of non-supplied gas per off-take point of the gas transport network, and eventually integrated for the entire network. In this paper, we focus our effort on the correct estimation of consequences of potential scenarios. Given the complex and dynamic behaviour of a national or regional gas transport system, this estimation can only be done with the adequate gas transport network simulation models. In previous work [2], a mathematical engine (**SAInt** - Scenario Analysis Interface for Energy Systems) has been developed for simulating hydraulic transients in gas transport networks under isothermal conditions. The use of a transient hydraulic model is inevitable, due to the dynamic nature of the prevailing processes in gas systems.

Nevertheless, the actual resolution of transport equations is not enough to simulate

the degrees of freedom of a network to react to a transient or, more severe, to a gas disruption. In normal operation Transmission System Operators (TSOs), following market decisions, network codes and network good practice management, have the capability to make decisions concerning the use of the different facilities of the network (production sites - PS, underground gas storage facilities - UGS, liquefied natural gas regasification terminals - LNG, compressor stations – CS, cross border import stations - CBI, cross border export points – CBE, etc.) in order to optimize its use. When a gas disruption takes place, according to the EP other actors may intervene, as for example the Competent Authority (CA), obliging the TSO to adopt specific actions to mitigate the impact of the crises on gas customers.

In this paper, we identify the different actions that the operator, market actors and authorities may adopt in the different steps of a gas crisis and the infrastructure elements used to implement them. Next, we identify the different possible control modes and constraints of each infrastructure element and implement them in **SAInt** to further develop its capabilities as an integrated simulation tool to analyze gas supply disruptions. Finally, we apply **SAInt** on a real world instance.

The paper is structured as follows. In section 2 a formal definition of risk is provided, where we focus on the 'consequence' element of the term 'Risk'. In section 3 we address the identification of the different measures that TSOs, authorities and market actors may adopt in the different steps of a gas crisis, and the types of facilities that may be affected by such decisions. Section 4 is dedicated to describing the different ways of controlling each type of facility and the manner to program such ways of control. Finally, in section 5 we show the actual implementation of the models developed in the previous sections by means of a real world instance.

2 Definition of Risk

The word 'risk' is frequently used in a very informal manner. Quite often, risk is defined as probability times consequences (or impact, or damage). Essentially, this means that a measure of risk has to account for potential consequences and weigh them with their corresponding probabilities (likelihoods). A more operational definition of risk follows in the next paragraphs. Standard ISO 31010 indicates that Risk Assessments attempt to answer the following fundamental questions:

- What can happen and why?
- What are the consequences?

- What is the probability of its future occurrence?

Kaplan and Garrick [3] showed that a formal answer to these three questions requires describing risk through the use of a set of triplets

$$R = \{ \langle s_i, \phi_i, y_i \rangle \quad i = 1, 2, \dots, N \} \quad (1)$$

where

1. s_i represents scenario i in the set of N scenarios considered.
2. ϕ_i is the probability of scenario i .
3. y_i is the potential consequence under the conditions of scenario i .

This constitutes a formal mathematical definition of risk, although it does not account for all sources of uncertainty. Under this definition each scenario is characterized by its probability and its consequence(s) (one or several consequence variables may be considered, but only one possible value of each consequence variable is considered). Adopting this definition of Risk means that all possible scenarios must be identified and the probability of each must be estimated. Moreover, for each scenario, the consequence(s) for the system must be assessed.

A RA, in order to be useful, has to be as accurate as possible, and certainly free of bias. The introduction of bias is a pervasive problem in RA. The most frequent reason to introduce bias in a RA is a poor identification of sources of risk (typically classified as hazards, equivalent to non-intentional events, and threats or intentional actions leading to undesired events). This problem produces in most occasions a severe underestimation of risk. This is the reason why many techniques have been developed in order to avoid this problem, from the simple brainstorming to the much more elaborate Failure Mode and Effect Analysis (FMEA) or the Hazard and Operability Analysis (HAZOP). Nevertheless, the incorrect assessment of consequences of different scenarios - gas crises -, leads certainly to biases in the estimation of risk, probably not as severe as the ones derived from a poor identification of sources of risk, but certainly undesired. This is a problem that has been systematically ignored in the literature. Typically, problems of gas disruptions have been addressed at a very coarse level of granularity, as much in space as in time [4–9].

3 Measures to Mitigate the Impact of Gas Disruptions

Regulation 994/2010 [1] on security of gas supply has as one of its key elements the EP. According to the Regulation, the EP has to be designed taking into account the results of the RA. The target of the EP is to mitigate as much as possible the effects of risky scenarios, in order to contribute to decreasing the risk level associated to the studied gas system. This means it has to be designed to react to the scenarios that introduce more risk into the system, decreasing their consequences as much as possible.

Regulation 994/2010 [1] builds the EP upon three crisis levels:

1. 'Early warning': when there is concrete, serious and reliable information that an event may occur which is likely to result insignificant deterioration of the supply situation.
2. 'Alert': when a supply disruption or exceptionally high gas demand occurs which results in significant deterioration of the supply situation, but the market is still able to manage the situation.
3. 'Emergency': in the event of exceptionally high gas demand, significant supply disruption or other significant deterioration of the supply situation and in the event that all relevant market measures have been implemented but the supply of gas is insufficient to meet the remaining gas demand so that non-market measures have to be additionally introduced.

As it can be seen in the definition of the three crisis levels, security of gas supply market measures and non-market measures are listed. The Regulation [1] considers in its annexes II and III the main market and non-market measures that may be adopted, and these are further classified as either supply side or demand side measures. This classification is provided in Tab. 1. Some of these measures have more to do with the PAP than with the EP, as for example diversification of gas supply routes, the deployment of new LNG regasification facilities or of new gas storage facilities, investments in infrastructure, including bi-directional capacity, among others. These are options that, if adopted, lead to decreased probabilities of some potential events / crises, but cannot be adopted when the crisis has already started. Measures that have to do with the EP are, for example, increased production flexibility, increased import flexibility, and reverse flows, among others. The security of supply measures considered in the Regulation [1] related to the EP, when implemented in case of crisis, involve necessarily the use of some network facilities. Normally, the operator will have to react to the event triggering the crisis by changing the operational mode of some of the facilities. For example, to

Tab. 1: Security of gas supply measures. Adapted from Regulation 994/2010 [1] on security of gas supply.

	Market measures	Non-market measures
Supply side measures	<ul style="list-style-type: none"> • increased production flexibility, • increased import flexibility, • facilitating the integration of gas from renewable energy sources into the gas network infrastructure (power to gas), • commercial gas storage-withdrawal capacity and volume of gas in storage, • LNG terminal capacity and maximal send-out capacity, • diversification of gas supplies and gas routes, • reverse flows, • coordinated dispatching by transmission system operators, • use of long-term and short-term contracts, • investments in infrastructure, including bi-directional capacity, • contractual arrangements to ensure security of gas supply. 	<ul style="list-style-type: none"> • use of strategic gas storage, • enforced use of stocks of alternative fuels (e.g. in accordance with Council Directive 2009/119/EC of 14 September 2009 imposing an obligation on Member States to maintain minimum stocks of crude oil and/or petroleum products (1)), • enforced use of electricity generated from sources other than gas, • enforced increase of gas production levels, • enforced storage withdrawal.
Demand side measures	<ul style="list-style-type: none"> • use of interruptible contracts, • fuel switch possibilities including use of alternative back-up fuels in industrial and power generation plants, • voluntary firm load shedding, • increased efficiency, • increased use of renewable energy sources. 	<ul style="list-style-type: none"> • enforced fuel switching, • enforced utilisation of interruptible contracts, where not fully utilised as part of market measures, • enforced firm load shedding.

react to a sudden drop in imports through an entry point, the operator could change the control mode of some other entry points from flow control to pressure control in order to keep the pressure at the normal operational level in the network, allowing the transport of gas to the areas close to the entry point affected by the gas disruption. This can be combined with a change in the control mode of other facilities to enhance the transport of gas in the desired direction, as for example CS. Tab. 2 shows the correspondence between the EP measures considered in the Regulation [1] and the network facilities needed to implement them. For example, increased import flexibility means having in place the right contracts that allow increase flows with relatively short notice to react to problems. The way to implement this measure in the model is acting on the control mode of the entry stations across which the shipper that provides that flexibility can put gas into the system. The same would apply to contractual arrangements signed to ensure security of gas supply.

The facilities modeled in **SAInt** to simulate the flexibility of a gas transport network under normal operation and under gas crisis situations are: entry stations (CBIs, PROs), exit stations (CGS,GPP,IND), UGS, LNG, and CS. In fact, entry and exit stations are modeled as nodes with flow or pressure control similar to the regulator and metering station installed in the actual station.

All measures that have to do with reduction of demand are simulated via exit stations. At the bottom of the table we can see coordinated dispatching by TSOs. This necessarily demands the use of all facilities available in the network. In the next section, we see the way all these facilities are modeled in **SAInt**, most remarkably their specific control modes and constraints.

4 Model of Gas Infrastructure

The system of equations describing the transient flow in gas systems can be expressed by the following linearized matrix equation, derived from the one-dimensional, isothermal continuity and momentum equation describing the gas flow in pipelines.

$$\begin{pmatrix} \Phi & -\mathbf{A}_P & -\mathbf{A}_N & \mathbf{I} \\ \mathbf{A}_{DP} & -\mathbf{R} & \mathbf{0} & \mathbf{0} \\ \mathbf{C}_P & \mathbf{0} & \mathbf{C}_N & \mathbf{0} \\ \mathbf{K}_P & \mathbf{0} & \mathbf{K}_N & \mathbf{K}_L \end{pmatrix} \begin{pmatrix} p^{n+1} \\ Q_P^{n+1} \\ Q_N^{n+1} \\ L^{n+1} \end{pmatrix} = \begin{pmatrix} \Phi p^n \\ B \\ E \\ S \end{pmatrix} \quad (2)$$

where p^{n+1} and L^{n+1} are vectors of nodal gas pressure and nodal load at a future time point t_{n+1} , and Q_P^{n+1} and Q_N^{n+1} are vectors of gas flow rates in pipe and non-

Tab. 2: Correspondence between EP measures and network facilities needed to implement them.

Measure adopted	Facility used
<ul style="list-style-type: none"> • increased production flexibility, • increased import flexibility, • use of long-term and short-term contracts, contractual arrangements to ensure security of gas supply. • enforced increase of gas production levels, • use of long-term and short-term contracts, contractual arrangements to ensure security of gas supply. 	<p><u>Exit Stations:</u></p> <p>CBI - Cross Border Entry Stations, PRO - Gas Production Fields</p>
<ul style="list-style-type: none"> • use of interruptible contracts, • fuel switch possibilities including use of alternative back-up fuels in industrial and power generation plants • voluntary firm load shedding • enforced use of stocks of alternative fuels (e.g. in accordance with Council Directive 2009/119/EC of 14 September 2009 imposing an obligation on Member States to maintain minimum stocks of crude oil and/or petroleum products (1)) • enforced use of electricity generated from sources other than gas, • enforced fuel switching • enforced utilisation of interruptible contracts, where not fully utilised as part of market measures • enforced firm load shedding 	<p><u>Exit Stations:</u></p> <p>CGS - City Gate Stations, GPP - Gas Fired Power Plant Stations, IND Stations of Large Industrial Customers, CBE - Cross Border Export Stations</p>
<ul style="list-style-type: none"> • commercial gas storage, • use of strategic gas storage, • enforced storage withdrawal. 	<p>UGS - Underground Gas Storage Facility</p>
<ul style="list-style-type: none"> • LNG terminal capacity and maximal send-out capacity, • increased import flexibility, • use of long-term and short-term contracts, contractual arrangements to ensure security of gas supply. 	<p>LNG - Liquefied Natural Gas Regasification Terminals</p>
<ul style="list-style-type: none"> • coordinated dispatching by transmission system operators 	<p>All</p>

pipe elements at a future time point t_{n+1} , respectively. The other matrices in eq. (2) are coefficient matrices, which depend on the state variables (p, Q, L), gas properties (relative density, gas viscosity etc.), pipe properties (length, diameter, roughness etc.) and properties of non-pipe facilities (adiabatic efficiency, driver efficiency, resistance factor etc.). The detailed derivation of eq. (2) can be found in [2].

4.1 Extended Iterative Time Integration Algorithm

The system of equations expressed in eq. (2) are solved based on the iterative time integration algorithm developed in [2], which has been extended to include a Dynamic Control Feasibility Algorithm (DFC), a Simulation Control Evaluation Algorithm (SCE) a Constraints and Control Handling Algorithm (CCH) for controlled non-pipe facilities (e.g. compressor stations and regulator stations) and a Dynamic Time Step Adaptation Method (DTA), which adapts the simulation time step Δt in relation to the control mode changes in order to capture these changes with a higher time resolution. Fig. 1 shows the flow diagram of the extended algorithm which is implemented in **SAInt**. Each case study in **SAInt** is modeled as a scenario which includes a time window, a global time step Δt_g , an initial state for the studied network and a list of scenario definitions, defined by the user prior to the actual solution process. As shown in Fig. 1 before the actual time integration process the program iterates through the list of scenario definitions. The algorithm for the remaining solution process contains three major loops, namely, the time integration loop, marked by the solid blue flow arrows, the constraints and control handling loop, illustrated by the dashed red flow arrows and the iterative loop, indicated by the dashdotted green flow arrows in Fig. 1. In the following, we explain briefly the function of these loops.

Time Integration Loop

The time integration loop is the outer loop of the transient solver. It has been extended by a dynamic control feasibility checking algorithm (DFC), which checks if a requested control change for a future time point t_{n+1} is feasible, considering the present control of the station at time point t_n . If a requested set point is not feasible, the DFC will change the station control to the next closest feasible working point. In addition, for some requested control changes, like for instance, turning an operating compressor station into bypass, the DFC makes use of a simulation control object (SCO), which enables the control of the station until a specified simulation time and/or until a specified

Fig. 1: Flow diagram of the transient hydraulic solver implemented in the simulation tool **SAInt**

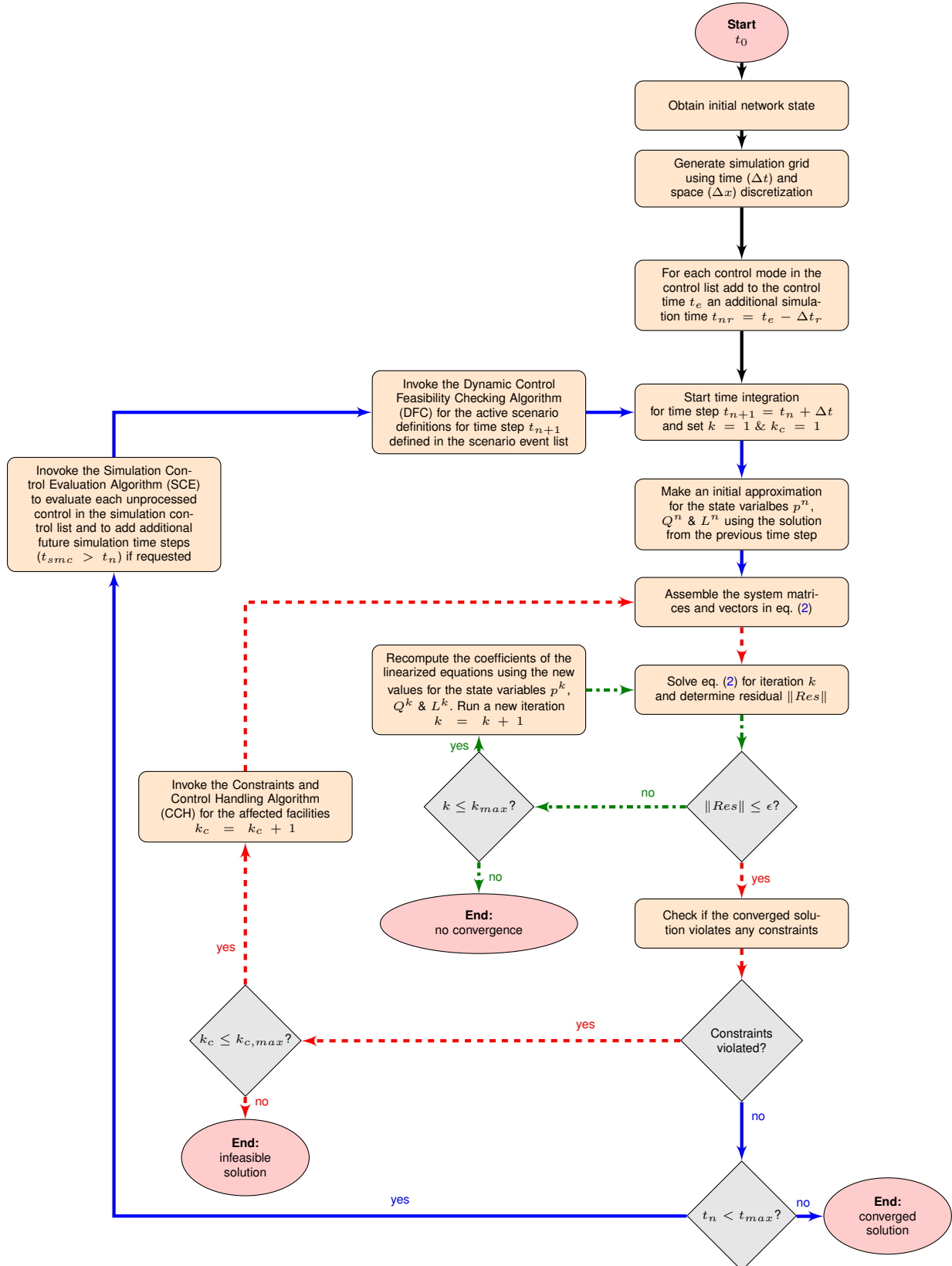

condition is fulfilled. The SCOs are stored in a simulation control list, which is processed before the start of each time integration loop.

Iterative Loop

The iterative loop, in contrast, is the inner loop of the transient solver and serves the purpose of solving the linearized system of equations (eq. (2)) iteratively. The solution of the system of equations requires an efficient linear equation solver for each iteration step. We have extended the linear solver used in [2] by a direct sparse solver specifically designed for solving large scale structurally unsymmetric sparse linear systems such as the system of equations expressed in eq. (2). The new solver enhances the capability of the simulation tool for solving large scale gas systems with thousands of elements with reasonable computation time and storage demand.

Constraints and Control Handling Loop

The constraints and control handling loop only comes into play if a station constraint has been violated. In this case, the CCH algorithm for the specific station is invoked. The idea behind the CCH loop is to repeat the iterative loop for the last time point t_n using new control settings for the affected station. The solver delivers to the CCH algorithm a list of constraint violation objects, which contain information on the violated parameters and their corresponding constraint levels. The constraint level is an indicator of the significance of each constraint and how it should be treated by the solver. It is subdivided into the following four levels:

1. **Warning:**

The solver issues a warning of a constraint violation without invoking the CCH algorithm.

2. **Soft limit:**

The solver invokes the CCH algorithm, which tries to find a feasible working point for a limited number of iterations. If no feasible working point is found the solver ignores the violated constraint and proceeds with the next time step (t_{n+1}).

3. **Hard limit:**

The solver invokes the CCH algorithm, which tries to find a feasible working point for a limited number of iterations. If no feasible working point is found the simulation is aborted.

4. Stop limit:

The solver aborts the simulation without invoking the CCH algorithm.

The CCH algorithm tries to find a compromise between the violated parameter and the existing control set point by generating a new control setting for the station. If necessary, the CCH algorithm can issue an SCO for the affected station, which is then added to the simulation control list and evaluated in the SCE for the specified simulation time.

4.2 Control Modes for Non-Pipe Facilities

Non-pipe facilities, such as compressor, regulator and valve stations play a key role in the operation and management of gas transport systems. These facilities enable the transmission system operator (TSO) to supervise and control the gas stream, pressure, temperature and the line pack in the pipeline system.

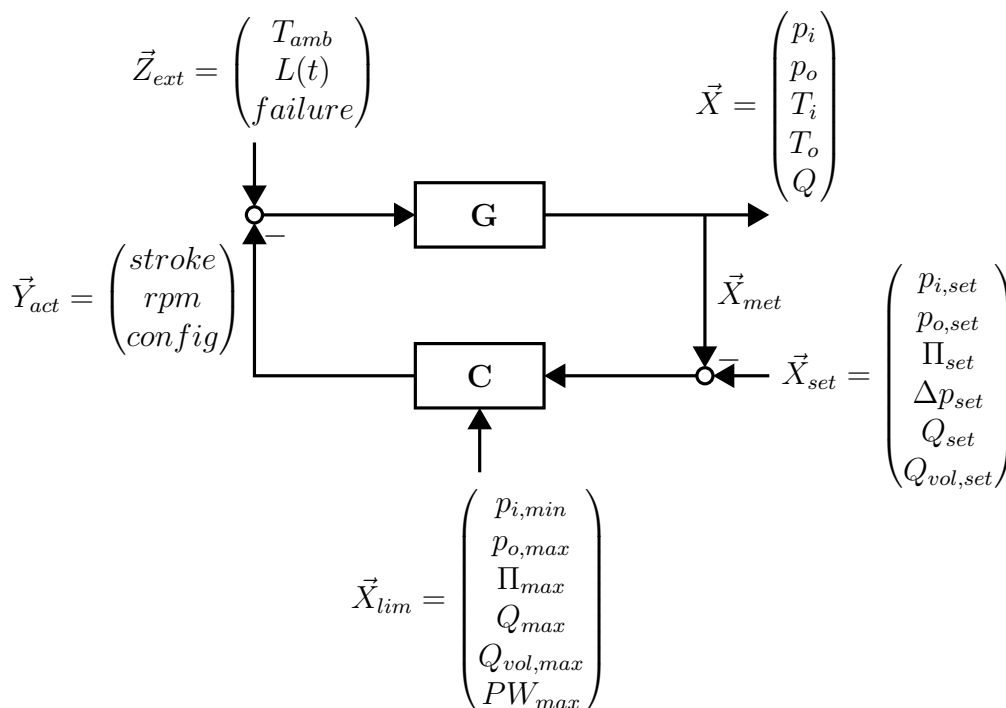

Compressor stations are usually installed every 150-300 kilometer along the gas pipeline system. Their function is to increase the gas pressure to compensate for the pressure losses incurred during transportation. Regulator stations, in contrast, are pri-

Fig. 2: A simplified functional diagram of a control system in a compressor or regulator station

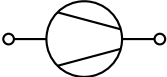

marily installed in combination with metering stations at all entry and exit stations and at the interface of two connected sub networks with different maximum operating pressure levels (MOP). The purpose of a regulator station is to reduce the upstream gas pressure to a lower downstream pressure and/or to regulate the quantity of gas flowing through the station. Valves in turn, are installed every 10-30 km along the pipeline system and serve the purpose of routing the gas stream and shutting down sections of the network for maintenance or in case of a disruption. Compressor stations and regulator

Tab. 3: Overview of available control modes and constraints settings for non-pipe facilities modeled as elements

Facility	Control Modes	Constraints
<p>Compressor Station</p> 	<p>inlet pressure ($p_{i,set}$) outlet pressure ($p_{o,set}$) pressure ratio (Π_{set}) pressure difference (Δp_{set}) flow rate (Q_{set}) volumetric flow ($Q_{vol,set}$) flow velocity (V_{set}) shaft power ($PW_{s,set}$) driver power ($PW_{d,set}$) driver fuel ($Q_{f,set}$) closed (<i>OFF</i>) bypass (<i>BP</i>)</p>	<p><u>internal hard limits:</u> $p_o \geq p_i$ & $Q \geq 0$</p> <p><u>user defined limits:</u> max. outlet pressure ($p_{o,max}$, 80 [barg]) min. inlet pressure ($p_{i,min}$, 25 [barg]) max. volumetric flow ($Q_{vol,max}$, 100 [m^3/s]) max. flow rate (Q_{max}) max. pressure Ratio (Π_{max}, 2 [-]) max. driver power ($PW_{d,max}$, 100 [MW])</p>
<p>Regulator Station</p> 	<p>inlet pressure ($p_{i,set}$) outlet pressure ($p_{o,set}$) pressure difference (Δp_{set}) flow rate (Q_{set}) volumetric flow ($Q_{vol,set}$) flow velocity (V_{set}) closed (<i>OFF</i>) bypass (<i>BP</i>)</p>	<p><u>internal hard limits:</u> $p_i \geq p_o$ & $Q \geq 0$</p> <p><u>user defined limits:</u> max. outlet pressure ($p_{o,max}$, 80 [barg]) min. inlet pressure ($p_{i,min}$, 25 [barg]) max. volumetric flow ($Q_{vol,max}$, 100 [m^3/s]) max. flow rate (Q_{max})</p>
<p>Valve Station</p> 	<p>closed (<i>OFF</i>) opened (<i>BP</i>)</p>	<p><u>internal hard limit:</u> $V \leq 60$ [m/s]</p> <p><u>user defined limits:</u> max. flow velocity (V_{max}, 30 [m/s])</p>

stations are typically operated at a desired set point, which is controlled by a designated automatic control system (ACS). The purpose of such a system is to keep the station at the desired set point and to ensure that station constraints are not violated. Fig. 2 shows a generic functional diagram of an ACS with a feedback loop, where \vec{X} marks the set of state variables at the station inlet and outlet (e.g. gas pressure p , temperature T and flow rate Q), G the set of (differential) equations describing the physical processes in the station (e.g. adiabatic gas compression, isenthalpic gas expansion etc.), \vec{Z}_{ext} the set of external factors directly influencing the physical process (e.g. ambient temperature T_{amb} , fluctuations in demand and supply $L(t)$, technical failures etc.), \vec{X}_{met} the set of metered state variables, \vec{X}_{set} the set of operating set points available to the dispatcher (e.g. flow rate set point Q_{set} , inlet and outlet pressure set point $p_{i,set}$ and $p_{o,set}$), C the control algorithm of the controller, \vec{X}_{lim} the set of station constraints (e.g. maximum outlet pressure, maximum available compression power) and \vec{Y}_{act} the set of available actuators to act on the process (percent opening of the regulator flow area, shaft revolution etc.). The state variables \vec{X} are continuously metered by sensors and metering devices installed in the station (\vec{X}_{met}). The metered data is then compared to the desired operating set point \vec{X}_{set} requested by the dispatcher. The dispatcher can only assign one set point at a time, since the ACS typically permits the control of only one state variable at a time. Additional set points are then treated as constraints. The deviations between the metering data \vec{X}_{met} and the set point \vec{X}_{set} are forwarded to the controller C . The controller then checks if the deviations are within acceptable margins and if the desired set point does not violate any station constraints (\vec{X}_{lim}). If a correction of the state variables is necessary to maintain the set point the controller makes use of the actuators \vec{Y}_{act} to act on the physical process G . In case a requested set point is not permitted the controller will typically relax the set point to the next closest possible operating point.

The described functions and controls of non-pipe facilities can be modeled in **SAInt** by defining a scenario parameter and assigning it to the specific facility. Tab. 3 & 4 show a list of available control modes and constraint parameters that can be assigned to the different non-pipe facilities in the simulation model.

4.3 Modeling of Measures to Mitigate the Impact of Disruptions

The different generic control modes for non-pipe facilities presented in the last section are similar to those available to TSOs to manage their actual systems and to react to disruptions in the GTS. A TSO can typically change the settings of each facility dynamically depending on the current state of the system and the forecasts for gas supply

Tab. 4: Overview of available control modes and constraints settings for non-pipe facilities modeled as nodes

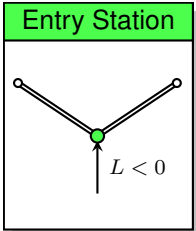
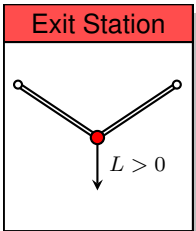
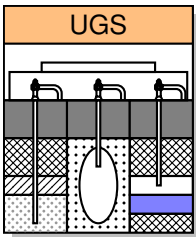
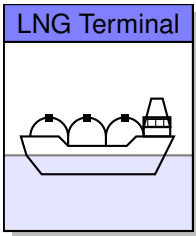
Facility	Control Modes	Constraints
	pressure (p_{set}) inflow (Q_{set})	<u>internal hard limits:</u> $L \leq 0$ <u>user defined limits:</u> min. supply flow (Q_{min}) max. supply flow (Q_{max}) min. supply pressure (p_{min}) max. supply pressure (p_{max})
	pressure (p_{set}) outflow (Q_{set})	<u>internal hard limits:</u> $L \geq 0$ <u>user defined limits:</u> min. delivery flow (Q_{min}) max. delivery flow (Q_{max}) min. delivery pressure (p_{min}) max. delivery pressure (p_{max})
	pressure (p_{set}) withdrawal/injection rate (Q_{set}) initial working inventory (INV) withdrawal state (WDR) injection state (INJ)	<u>internal hard limits:</u> $L^{wdr} \leq 0$ & $L^{inj} \geq 0$ <u>user defined hard limits:</u> max. working inventory ($I_{w,max}$) max. withdrawal rate ($Q_{wdr,max}$) max. injection rate ($Q_{inj,max}$) <u>user defined limits:</u> max. supply pressure ($p_{wdr,max}$) min. offtake pressure ($p_{inj,min}$)
	pressure (p_{set}) regasification rate (Q_{set}) initial working inventory (INV) arriving vessel size ($VESSEL$)	<u>internal hard limits:</u> $L \leq 0$ <u>user defined hard limits:</u> max. working inventory ($I_{w,max}$) max. regasification rate ($Q_{reg,max}$) <u>user defined limits:</u> max. supply pressure ($p_{reg,max}$)

and demand. In case of a disruption, the TSO will typically follow a strict sequence of actions and measures (protocol) to mitigate the impact of the disruption. The degrees of freedom available to the TSO to apply these measures, which are included in the Emergency Plan and are based on the events identified in the Risk Assessment, will depend on the legal commitments with other stakeholders (gas customers, shippers, producers, competent authorities etc.) and the technical restrictions imposed by the gas infrastructure (pressure, flow and power limits etc.). To model these actions together with the available control modes listed in Tab. 3 & 4, we introduce a conditional expression for the execution of a requested control change of non-pipe facilities. The conditional expression may depend on a number of different network parameters, such as the line pack level, available supply and facilities, current gas demand. By doing this, we enable the simulation model to react dynamically to a disruption, similar to how a TSO would react in reality, allowing by these means a more realistic simulation of the gas network behavior and a better quality estimation of gas crises consequences. Furthermore, to model the different entities and their responsibilities in the combined simulation model of interconnected multinational gas transport systems, we introduce the possibility of dividing the simulation model into different subsystems, which we then assign to the different entities responsible for their operation. Each subsystem has the same properties as the total network model. This way, we can use the parameters of the subsystems in the conditional expressions to request a change in control mode. For instance, we could impose an increase in gas supply to a subsystem in case of a drop in line pack below a certain threshold. In the next section, we give a brief description of the developed simulation software. Finally, we demonstrate the capabilities of the software by applying it to a real world instance.

5 Model Application

The models presented in this paper have been implemented in a simulation software - **SAInt** (Scenario Analysis Interface for Energy Systems), which has been developed in MS Visual Studio .NET with the object oriented programming languages VB.NET, C# and C++. **SAInt** is divided into two separate modules, namely, **SAInt-API** (Application Programming Interface) and **SAInt-GUI** (Graphical User Interface). The API, is the main library of the software and contains all solvers and classes for instantiating the different objects comprising the gas system model (nodes, pipes, compressors etc.). The API is independent of the GUI and can be used separately in any other environment supporting .NET libraries (e.g. MS Excel, Visual Studio etc., Iron Python).

Fig. 3: Snapshot of the network model of the Bulgarian-Greek NGTs in the graphical user interface of the simulation tool SAInt

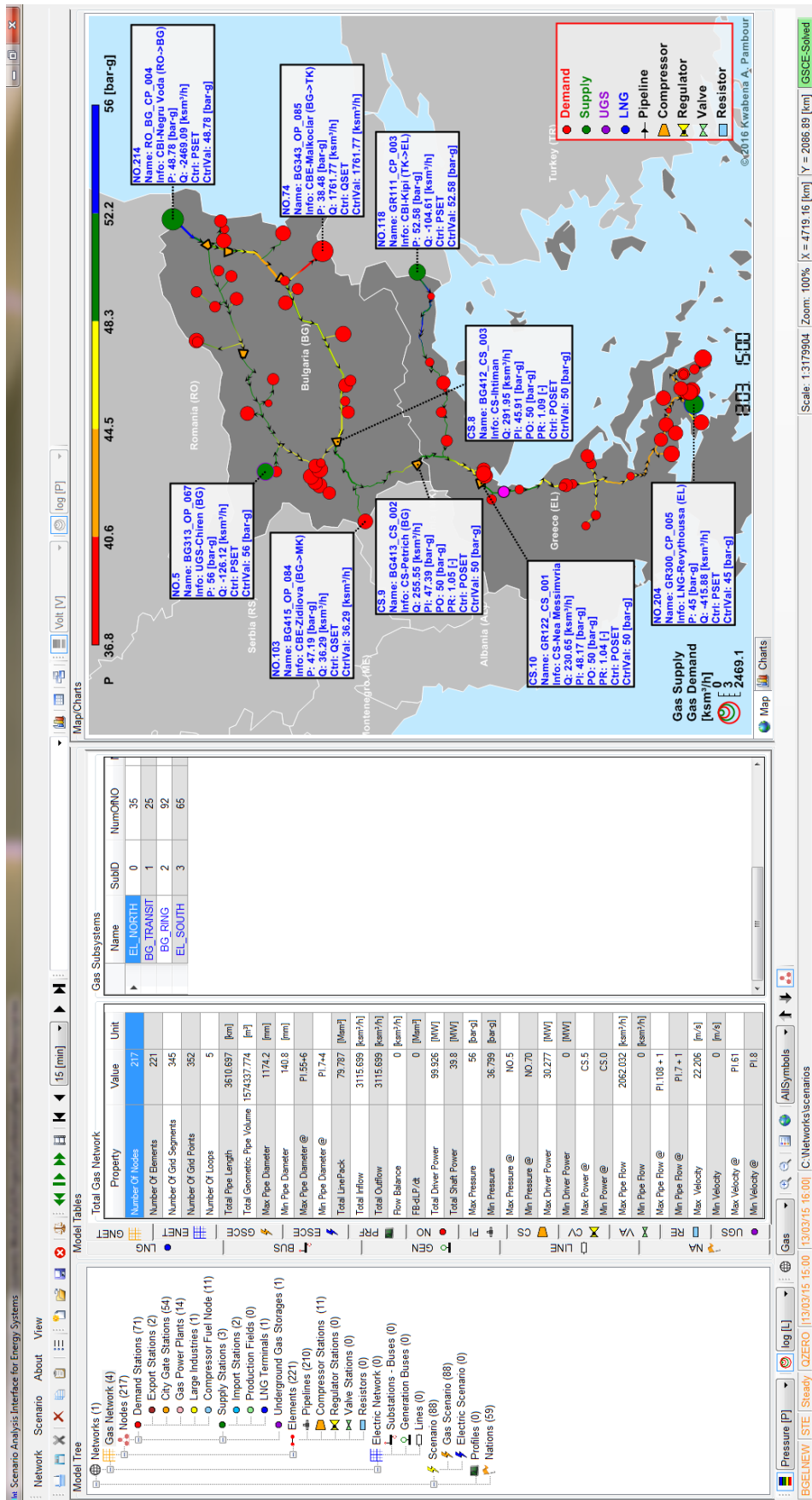

SAInt-GUI is the graphical interface, which enables a visual communication between the API and the user. The GUI uses the classes and solvers provided by the API to perform the simulation tasks requested by the user.

In this section, we apply the models implemented in **SAInt** to perform a case study on one of the regions affected by the gas crisis in January 2009, namely, the Bulgarian and Greek National Gas Transport Systems (NGTS). In the case study, we assess the

Fig. 4: Assigned subsystems in the Bulgarian-Greek simulation model

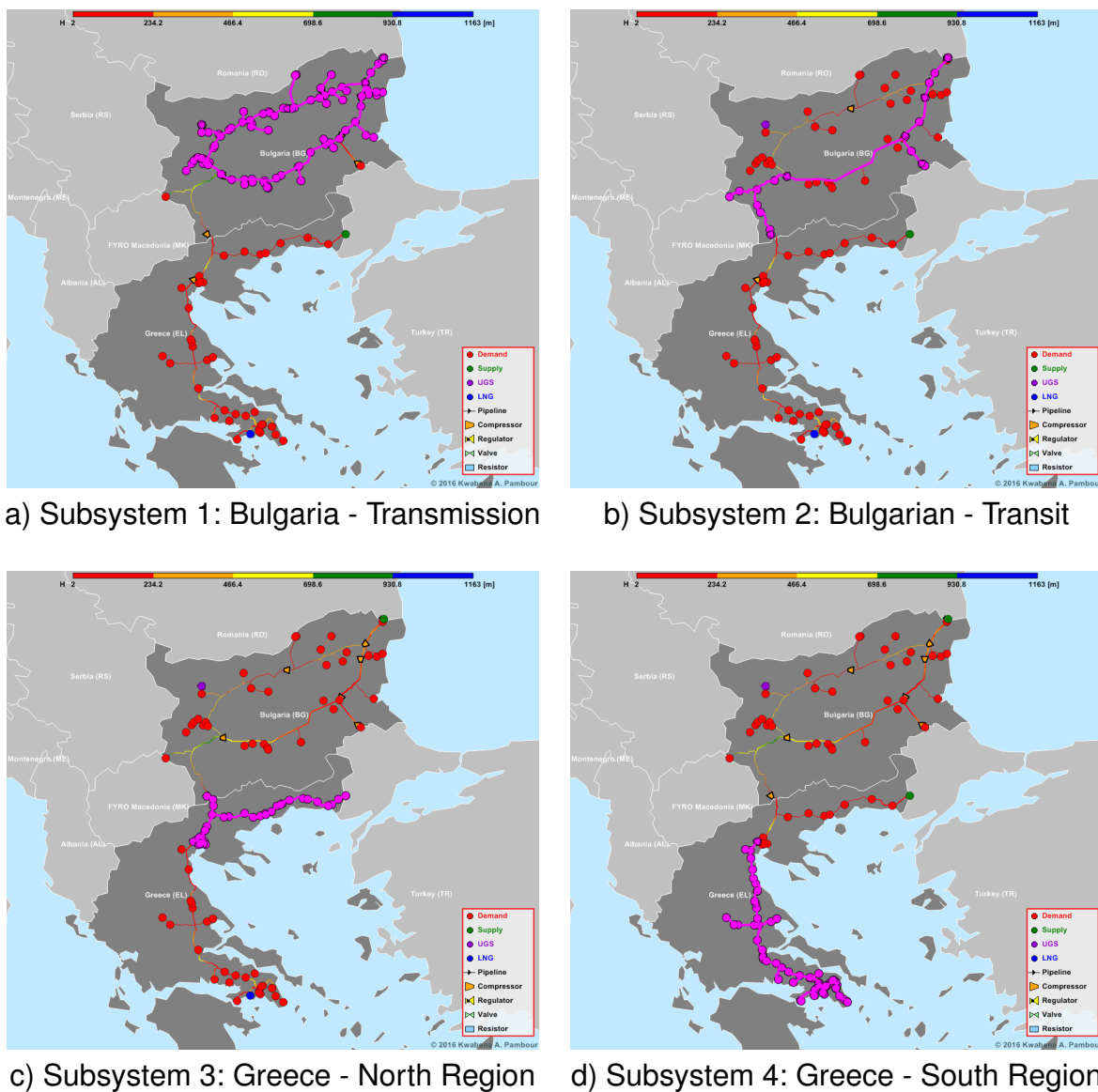

resilience of the network in case of a disruption in a compressor station. We apply mitigation measures to reduce the impact of the disruption by changing the settings of specific facilities using conditional control settings. Fig. 3 shows a snapshot of the

network model in the graphical user interface of **SAInt**. As illustrated in Fig. 3 and

Tab. 5: Properties of the Bulgarian-Greek NGTS

Property	Value	Unit
Number Of Nodes	217	
Number Of Elements	221	
Number Of Grid Segments	345	
Number Of Grid Points	352	
Number Of Loops	5	
Total Pipe Length	3610.697	[km]
Total Geometric Pipe Volume	1574337.774	[m ³]
Max Pipe Diameter	1174.2	[mm]
Min Pipe Diameter	140.8	[mm]

Tab. 6: Properties of the assigned subsystems

Subsystem	Nodes	Elements	Supply	Demand	Compressor
BG_RING	92	95	0	32	4
BG_TRANSIT	25	27	1	2	6
EL_NORTH	35	34	1	11	0
EL_SOUTH	65	65	1	26	1

Tab. 7: Input parameter for transient simulation of the Bulgarian-Greek network model

Parameter	Symbol	Value	Unit
time step	Δt	900	[s]
total simulation time	t_{max}	48	[h]
gas temperature	T	288.15	[K]
dynamic viscosity	η	10^{-5}	[kg/m · s]
standard pressure	p_n	1.01325	[bar]
standard temperature	T_n	273.15	[K]
relative density	d	0.6	[-]

Tab. 5, the Bulgarian-Greek simulation model comprises of 210 pipe elements (total pipe length of approx. 3600 [km] and total geometric pipe volume of approx. 1.6 Million m³), 11 compressor stations (10 located in Bulgaria and 1 in Greece) and 217 nodes (67 exit stations to the local distribution system (CGS) and to direct served customers (GPP, IND), two Cross Border Export Stations (CBE), 2 Cross Border Import

Fig. 5: Snapshot of the **SAInt**-Node-Editor showing the assigned constraints to CBI-Negru Voda

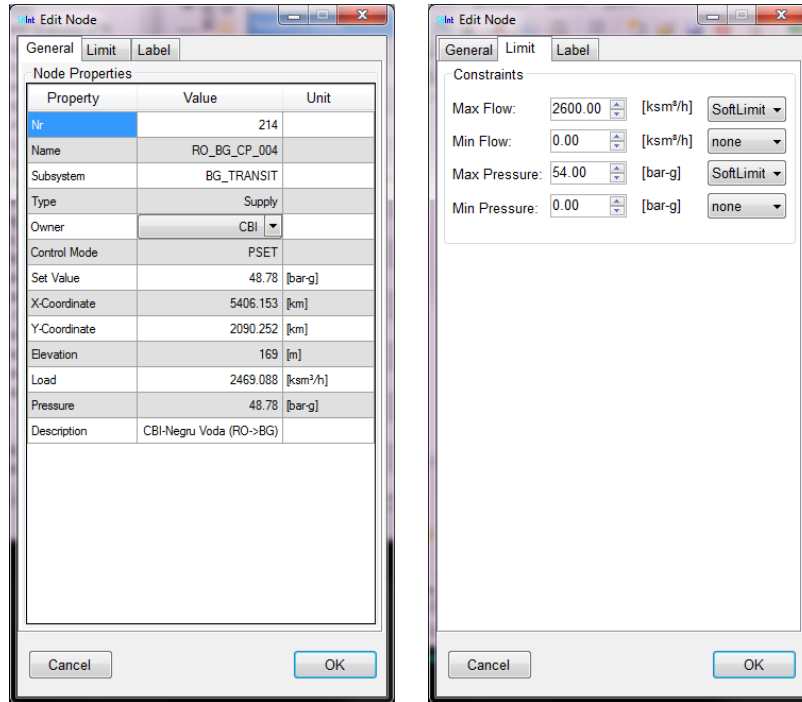
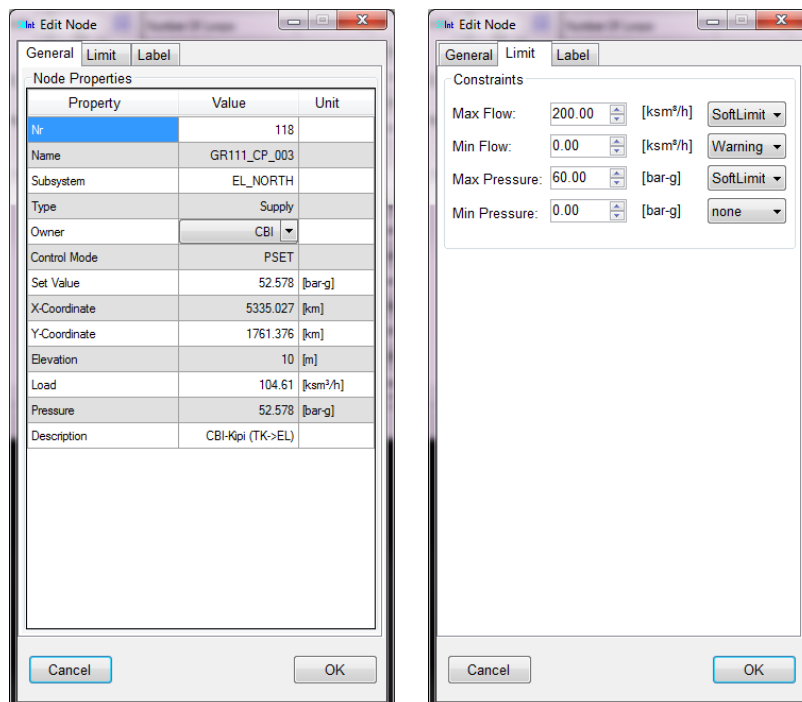
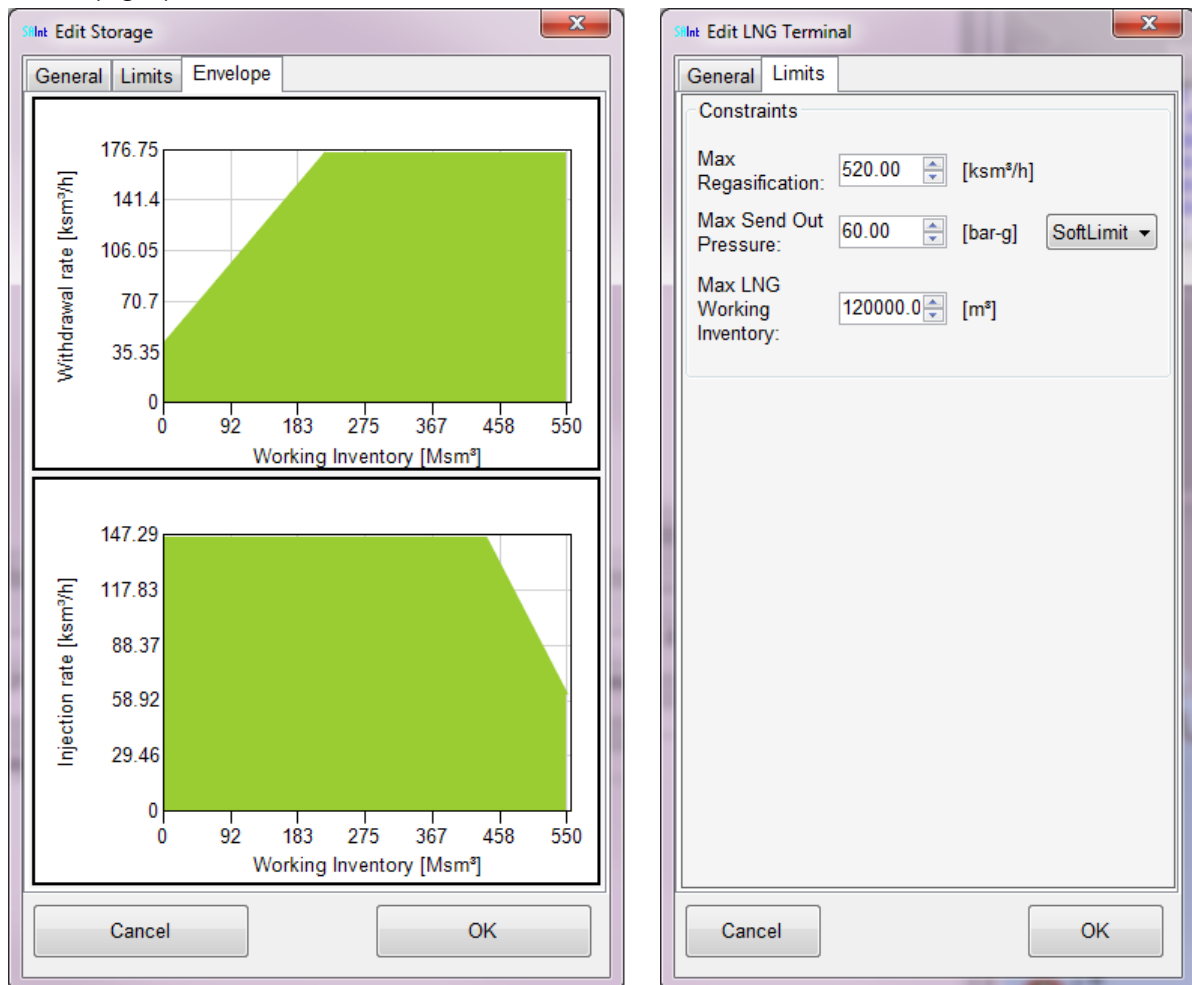

Fig. 6: Snapshot of the **SAInt**-Node-Editor showing the assigned constraints to CBI-Kipi



Stations (CBI), one LNG Terminal and one Underground Gas Storage Facility (UGS)). The Bulgarian-Greek NGTS is basically structured into two national transmission sys-

Fig. 7: Snapshot of **SAInt**-Storage Editor (left) and LNG-Terminal-Editor (right) showing the assigned properties for UGS-Chiren (left) and LNG-Terminal-Revythoussa (right)



tems and a transit pipeline transporting a large quantity of gas from CBI Negru Voda to the CBEs at the border to Turkey (Malcoclar), FYRO Macedonia (Zidilova) and Greece (Sidirokastron). Apart from CBI-Negru Voda, there are three additional entry points to the NGTS, namely, UGS-Chiren in Bulgaria (depleted gas field storage with supply from storage during winter and injection during summer), LNG Terminal -Revythoussa, Greece, and CBI-Kipi at the Greek-Turkish border. For the case study, we divide the network model into four subsystems, as shown in Fig. 4 and Tab. 6. We will use the parameters of the subsystems to define conditional expressions for the control of surrounding non-pipe facilities.

In order to start the dynamic simulation, we need an initial state of the network model,

Fig. 8: **SAInt**-Profile-Editor showing the relative 24h load profile assigned to demand nodes representing city gate stations

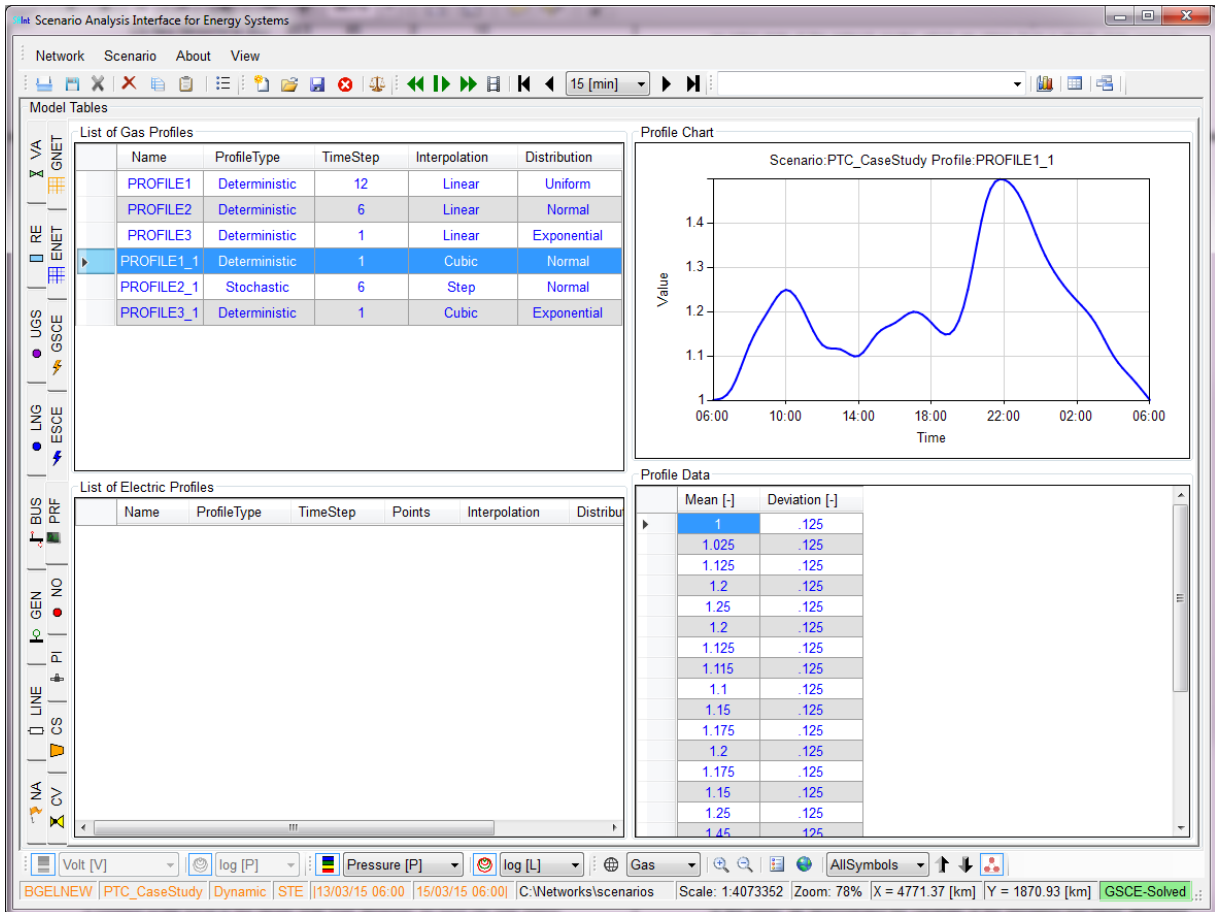

which we obtain from a steady state computation. The results of the steady state computation is shown in the map in Fig. 3, where the pressure and load distribution and the gas flow direction in the pipelines are depicted. The input data for the loads are based on peak winter consumption in 2011. Moreover, each supply node in the model is pressure controlled, while each compressor station (except the compressor station at UGS-Chiren, which is typically used for storage injection) is outlet pressure controlled with pressure set points ranging between 40-54 [barg]. For the cross border import stations Negru Voda and Kipi, we define constraints for the maximum pressure and maximum supply quantity, as shown in the snapshot of the node dialogs in Fig. 5 & 6. For the dynamic simulation, we assign to the demand nodes representing city gate stations the characteristic relative load profile depicted in Fig. 8, which we multiply with the corresponding steady state loads. For the other demand nodes, we assume a

Fig. 9: Snapshot of the **SAInt** scenario definition table showing the defined boundary conditions disruption events and mitigation strategy for the case study

Active	Time	Evaluation	Condition	Object	Nr	Parameter	Profile	Value	Unit
<input checked="" type="checkbox"/>	13/03 06:00	NONE		NO	50	QSET	PROFILE1_1	1.494	[ksm ² /h]
<input checked="" type="checkbox"/>	13/03 06:00	NONE		NO	28	QSET	PROFILE1_1	2.86	[ksm ² /h]
<input checked="" type="checkbox"/>	13/03 06:00	NONE		NO	30	QSET	PROFILE1_1	2.759	[ksm ² /h]
<input checked="" type="checkbox"/>	13/03 06:00	NONE		NO	166	QSET	PROFILE1_1	1.662	[ksm ² /h]
<input checked="" type="checkbox"/>	13/03 06:00	NONE		NO	167	QSET	PROFILE1_1	12.913	[ksm ² /h]
<input checked="" type="checkbox"/>	13/03 06:00	NONE		NO	164	QSET	PROFILE1_1	12.827	[ksm ² /h]
<input checked="" type="checkbox"/>	13/03 06:00	NONE		NO	145	QSET	PROFILE1_1	47.296	[ksm ² /h]
<input checked="" type="checkbox"/>	13/03 06:00	NONE		NO	157	QSET	PROFILE1_1	1.234	[ksm ² /h]
<input checked="" type="checkbox"/>	13/03 06:00	NONE		NO	163	QSET	PROFILE1_1	1.025	[ksm ² /h]
<input checked="" type="checkbox"/>	13/03 06:00	NONE		NO	168	QSET	PROFILE1_1	605	[ksm ² /h]
<input checked="" type="checkbox"/>	13/03 06:00	NONE		NO	175	QSET	PROFILE1_1	73.891	[ksm ² /h]
<input checked="" type="checkbox"/>	13/03 06:00	NONE		NO	210	QSET	PROFILE1_1	5.529	[ksm ² /h]
<input checked="" type="checkbox"/>	13/03 06:00	NONE		NO	212	QSET	PROFILE1_1	24.439	[ksm ² /h]
<input checked="" type="checkbox"/>	13/03 06:00	NONE		NO	213	QSET	PROFILE1_1	837	[ksm ² /h]
<input checked="" type="checkbox"/>	13/03 06:00	NONE		NO	209	QSET	PROFILE1_1	1.444	[ksm ² /h]
<input checked="" type="checkbox"/>	13/03 06:00	NONE		NO	179	QSET	PROFILE1_1	.093	[ksm ² /h]
<input checked="" type="checkbox"/>	13/03 06:00	NONE		NO	186	QSET	PROFILE1_1	51	[ksm ² /h]
<input checked="" type="checkbox"/>	13/03 06:00	NONE		NO	122	QSET	PROFILE1_1	684	[ksm ² /h]
<input checked="" type="checkbox"/>	13/03 06:00	NONE		NO	112	QSET	PROFILE1_1	56.237	[ksm ² /h]
<input checked="" type="checkbox"/>	13/03 06:00	NONE		NO	146	QSET	PROFILE1_1	42.622	[ksm ² /h]
<input checked="" type="checkbox"/>	13/03 06:00	NONE		NO	119	QSET	PROFILE1_1	249	[ksm ² /h]
<input checked="" type="checkbox"/>	13/03 06:00	NONE		NO	111	QSET	PROFILE1_1	1.219	[ksm ² /h]
<input checked="" type="checkbox"/>	13/03 06:00	NONE		NO	130	QSET	PROFILE1_1	.026	[ksm ² /h]
<input checked="" type="checkbox"/>	13/03 06:00	NONE		NO	208	QSET	PROFILE1_1	.96	[ksm ² /h]
<input checked="" type="checkbox"/>	13/03 06:00	NONE		NO	150	QSET	PROFILE1_1	952	[ksm ² /h]
<input checked="" type="checkbox"/>	13/03 06:00	NONE		NO	154	QSET	PROFILE1_1	3.977	[ksm ² /h]
<input checked="" type="checkbox"/>	13/03 06:00	NONE		NO	165	QSET	PROFILE1_1	.561	[ksm ² /h]
<input checked="" type="checkbox"/>	13/03 06:00	NONE		NO	131	QSET	PROFILE1_1	18.403	[ksm ² /h]
<input checked="" type="checkbox"/>	13/03 06:00	NONE		NO	133	QSET	PROFILE1_1	1.495	[ksm ² /h]
<input checked="" type="checkbox"/>	13/03 06:00	NONE		NO	143	QSET	PROFILE1_1	14.154	[ksm ² /h]
<input checked="" type="checkbox"/>	13/03 06:00	NONE		NO	155	QSET	PROFILE1_1	2.024	[ksm ² /h]
<input checked="" type="checkbox"/>	13/03 12:00	DoIFTRUE	gsub_EL_SOUTH.lp.[Msm3]>12.5	CS	8	POSET	-	50	[bar-g]
<input checked="" type="checkbox"/>	13/03 12:00	DoUntilTRUE	gsub_EL_SOUTH.lp.[Msm3]<12.5	CS	8	POWMAX	-	-	-
<input checked="" type="checkbox"/>	13/03 12:00	NONE		CS	9	OFF	-	-	-
<input checked="" type="checkbox"/>	13/03 12:00	DoIFTRUE	gsub_EL_NORTH.PMIN.[barg]<30	CS	10	PISET	-	35	[bar-g]
<input checked="" type="checkbox"/>	14/03 00:00	NONE		CS	9	BP	-	-	-

constant profile equal to the steady state load. Moreover, for each city gate station, we define a minimum delivery pressure limit of 20 [barg] and for the two cross border export stations a minimum delivery pressure of 30 [barg]. Furthermore, for UGS-Chiren and LNG-Revythoussa, we use the storage envelope and facility limits shown in the snapshot of the storage and LNG-Terminal dialog in Fig. 7. Additional simulation settings and gas properties are listed in Tab. 7.

To assess the resilience of the network and to show the capability of the simulation tool to model the reaction of the gas system to supply disruptions, we introduce a disruption in the compressor station CS-Petrich located at the Bulgarian-Greek border. Fig. 9 shows a snapshot of the **SAInt**- Scenario Definition Table, where the different control parameter definitions are listed. After the start of the simulation (6:00), we interrupt the gas flow from the Bulgarian transit pipeline to Greece by shutting down the compressor station CS-Petrich at 12:00. The flow interruption is relaxed 12 hours later at midnight 00:00 by changing the control mode of the station to bypass. To mitigate the supply dis-

Fig. 10: Time series of Line Pack (LP) and Minimum Pressure (PMIN) in the subsystems EL_NORTH (GSUB.0) and EL_SOUTH (GSUB.3)

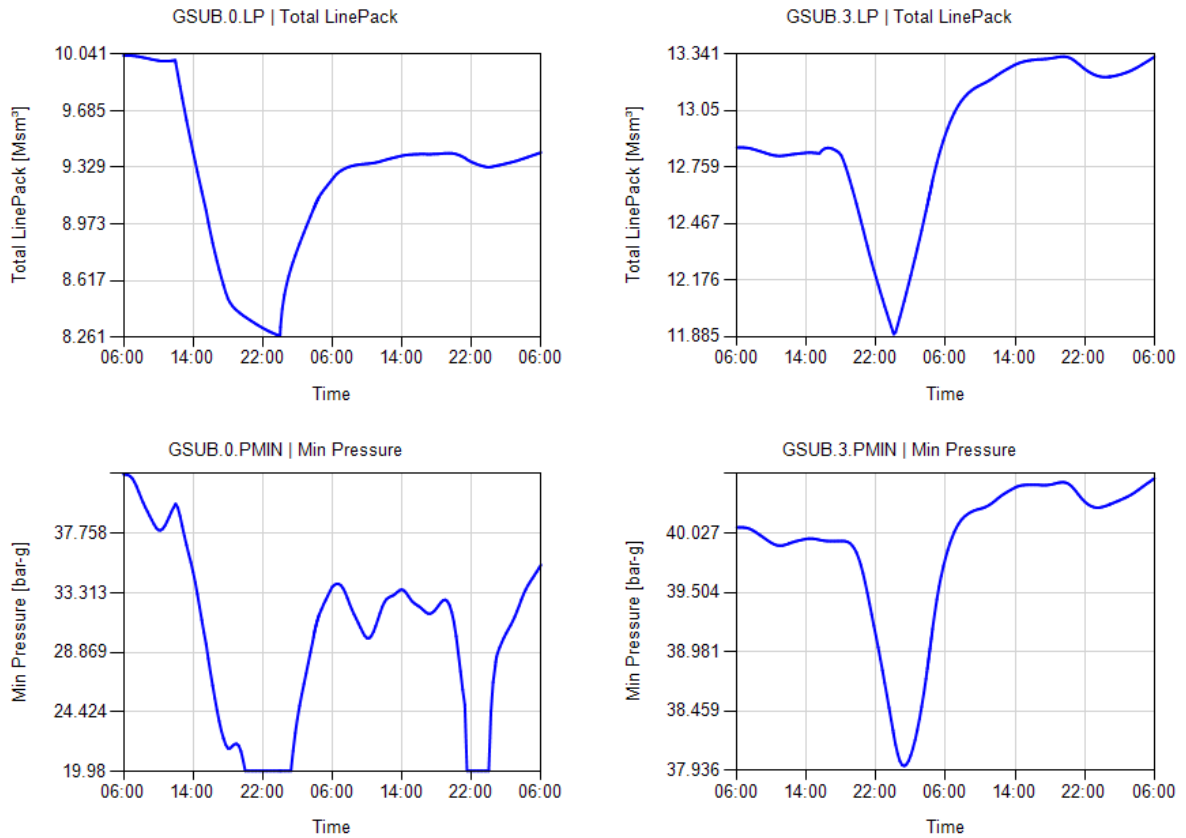

ruption, we define conditional control settings to the surrounding compressor stations, namely, CS-Ihtiman and CS-Nea Messimvria. We request a change in control mode for CS-Nea Messimvria from outlet pressure to inlet pressure control with a control set point of 35 [bar-g], if the minimum pressure in the subsystem EL_North is below 30 [bar-g], in order to stabilize the pressure in EL_North.

In addition, we request a change in control mode for CS-Ihtiman from outlet pressure

control to maximum driver power control, whenever the line pack in the subsystem EL_South goes below 12.5 [Msm³]. If the line pack is above this threshold, we request the station to return to its original outlet pressure control. In reality such a control change, would require the coordination of the two TSOs as indicated in the list of mitigation measures in Tab. 2. The results of the computation are shown in Fig. 11 - 17 and are discussed in the following.

Fig. 11 - 13 show the time series of the station control, inlet and outlet pressure and flow rate for the compressor stations CS-Ihtiman (top plot, CS.8), CS-Petrich (middle plot, CS.9) and CS-Nea Messimvria (bottom plot, CS.10). As can be seen in the middle time plots, the flow through CS-Petrich is interrupted at 12:00, causing the inlet pressure to increase and the outlet pressure of the station to decrease. The disruption also affects the pressure level and total line pack in the subsystem EL_North as depicted in figure 10, where the total line pack and the minimum pressure in the subsystems EL_North (GSUB.0) and EL_South (GSUB.3) are depicted. At approximately 15:00 the minimum pressure in subsystem EL_North drops below 30 [barg], which is the threshold for changing the control of CS-Nea Messimvria to inlet pressure control. At the time where this condition is fulfilled, the inlet pressure of CS-Nea Messimvria is above the requested set point of 35 [barg], thus, to achieve the requested set point the station compresses more gas from the suction to the discharge side, causing the flow rate to increase (s. bottom plot of Fig. 13) and the driver power to reach its maximum value (s. bottom plot of Fig. 11). The requested inlet pressure set point is finally reached at approx 18:00 (s. bottom plot of Fig. 12).

The effect of the second mitigation measure can be seen if we compare the time series of the line pack in subsystem EL_South (Fig. 10) and the time series for the compressor station CS-Ihtiman. At approx. 21:00 the line pack in subsystem EL_South drops below 12.5 [Msm³], causing the compressor station to change its original pressure outlet set point from 50 [barg] to the maximum outlet pressure [54 barg]. This set point differs from the requested maximum driver power control (s. Fig. 9). The reason for this is, that operating the compressor station at maximum driver power would violate the maximum outlet pressure constraint, thus the constraint and control handling algorithm considers the next feasible working point, which in this case is the maximum outlet pressure.

The maximum outlet pressure control is relaxed at approx. 4:00, when the line pack in subsystem EL_South rises above 12.5 [Msm³]. In this case the station is set back to its original outlet pressure control of 50 [barg]. Since the original pressure set point is below the outlet pressure at 4:00 (54 [barg]), the flow through the station is firstly interrupted until the outlet pressure drops back to 50 [barg].

Fig. 11: Time series of station controls for compressor stations CS-Ihtiman (CS.8), CS-Petrich (CS.9) & CS-Nea Messimvria (CS.10)

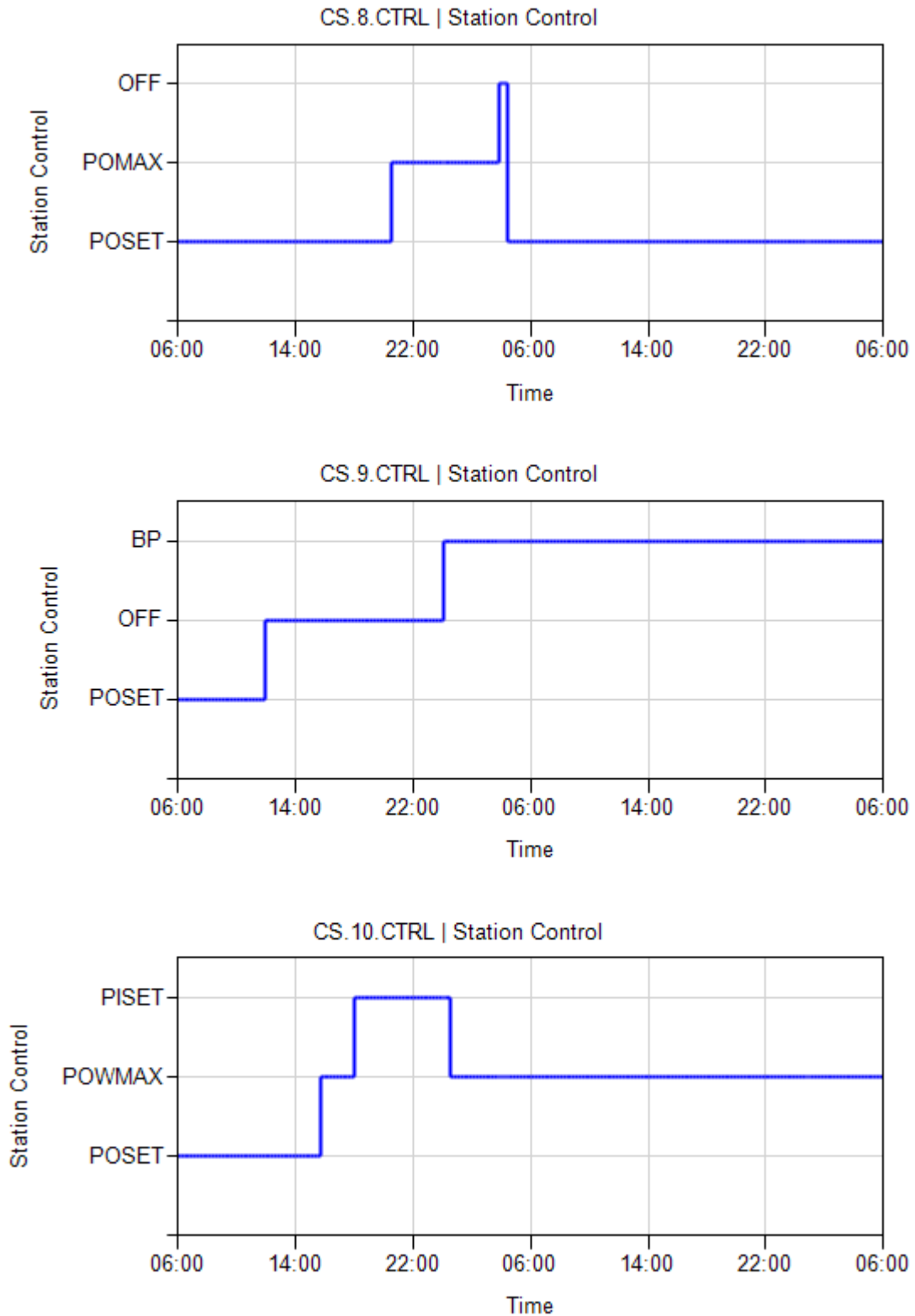

Fig. 14-17 show the time series of the station control, pressure and load for the four entry points CBI-Negru Voda, CBI-Kipi, UGS-Chiren and LNG-Revythoussa. In these plots, we see the effect of the station constraints on the control set point of the station and also how the disruption in CS-Petrich affected the entry points. The most affected facilities are CBI-Kippi and LNG-Revythoussa, where the gas supply rises to its maximum, in order to balance the demand in the northern and southern Greek region.

6 Conclusion

In this paper, we presented a transient hydraulic simulation tool for analyzing the consequences of natural gas supply disruptions. In the first part, we gave a formal definition of the term Risk and discussed the different elements comprising a Risk Assessment, namely, the identification of potential scenarios and the estimation of their probability and consequences. We pointed out the importance of estimating the consequences of potential scenarios in an adequate manner, using hydraulic models that reflect the dynamic behavior of the gas transport systems appropriately. Furthermore, we gave an overview of the different mitigation measures that can be adopted to reduce the impact of gas supply disruptions and the facilities in the gas infrastructure to apply these measures. Next, we presented an algorithm for solving the physical equations describing the dynamic behavior of gas transport systems. In addition, we elaborated how to model the control settings of non-pipe facilities such as compressor stations and regulator stations and how these control modes are implemented in the simulation tool **SAInt**. Finally, we apply the methods developed in this paper to a real world instance, where we demonstrated capability of the developed tool to simulate gas supply disruptions and to model and assess demand and supply side measures to mitigate the impact of gas supply disruptions.

In the near future, we intend to extend the simulation tool to include a model of the electric power system, in order to analyze the interdependency of gas and electric power systems in an integrated manner.

References

- [1] European Union, "Regulation (EU) No 994/2010 of the European Parliament and the Council of 20 October 2010 concerning measures to safeguard security of gas supply and repealing Council Directive 2004/67/EC," *Official Journal of the*

- European Union, 2010, <http://eur-lex.europa.eu/legal-content/EN/TXT/PDF/?uri=CELEX:32010R0994&from=EN>, April 11, 2016.
- [2] K. A. Pambour, R. Bolado-Lavin, and G. P. Dijkema, “An integrated transient model for simulating the operation of natural gas transport systems,” *Journal of Natural Gas Science and Engineering*, vol. 28, pp. 672 – 690, 2016.
- [3] S. Kaplan and B. Garrick, *On the Quantitative Definition of Risk*, *Risk Analysis*, vol. 1. 1981.
- [4] P. Praks, V. Kopustinskas, and M. Masera, “Probabilistic modelling of security of supply in gas networks and evaluation of new infrastructure,” *Reliability Engineering & System Safety*, vol. 144, pp. 254 – 264, 2015.
- [5] A. Szikszai and F. Monforti, “Gemflow: A time dependent model to assess responses to natural gas supply crises,” *Energy Policy*, vol. 39, no. 9, pp. 5129 – 5136, 2011.
- [6] N. Voropai, S. Senderov, and A. Edelev, “Detection of “bottlenecks” and ways to overcome emergency situations in gas transportation networks on the example of the european gas pipeline network,” *Energy*, vol. 42, no. 1, pp. 3 – 9, 2012. 8th World Energy System Conference, {WESC} 2010.
- [7] F. Monforti and A. Szikszai, “A montecarlo approach for assessing the adequacy of the european gas transmission system under supply crisis conditions,” *Energy Policy*, vol. 38, no. 5, pp. 2486 – 2498, 2010. Greater China Energy: Special Section with regular papers.
- [8] R. Carvalho, L. Buzna, F. Bono, M. Masera, D. K. Arrowsmith, and D. Helbing, “Resilience of natural gas networks during conflicts, crises and disruptions,” *PLoS ONE*, vol. 9, p. e90265, 03 2014.
- [9] S. Lochner, “Modeling the european natural gas market during the 2009 russian–ukrainian gas conflict: Ex-post simulation and analysis,” *Journal of Natural Gas Science and Engineering*, vol. 3, no. 1, pp. 341 – 348, 2011.

Fig. 12: Time series of inlet pressure (PI) and outlet pressure (PO) for compressor stations CS-Ihtiman (CS.8), CS-Petrich (CS.9) & CS-Nea Messimvria (CS.10)

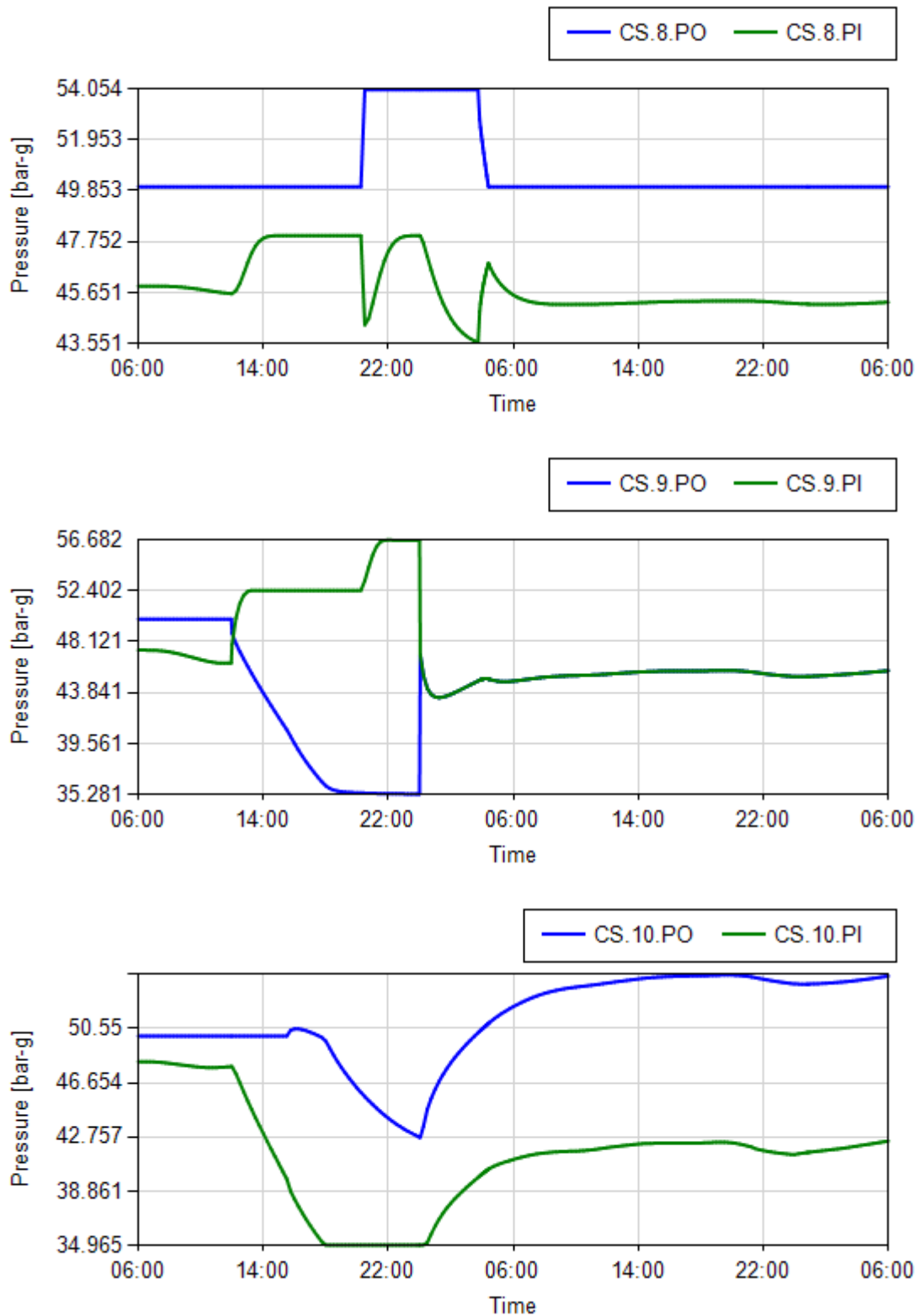

Fig. 13: Time series of flow rate (Q) for compressor stations CS-Ihtiman (CS.8), CS-Petrich (CS.9) & CS-Nea Messimvria (CS.10)

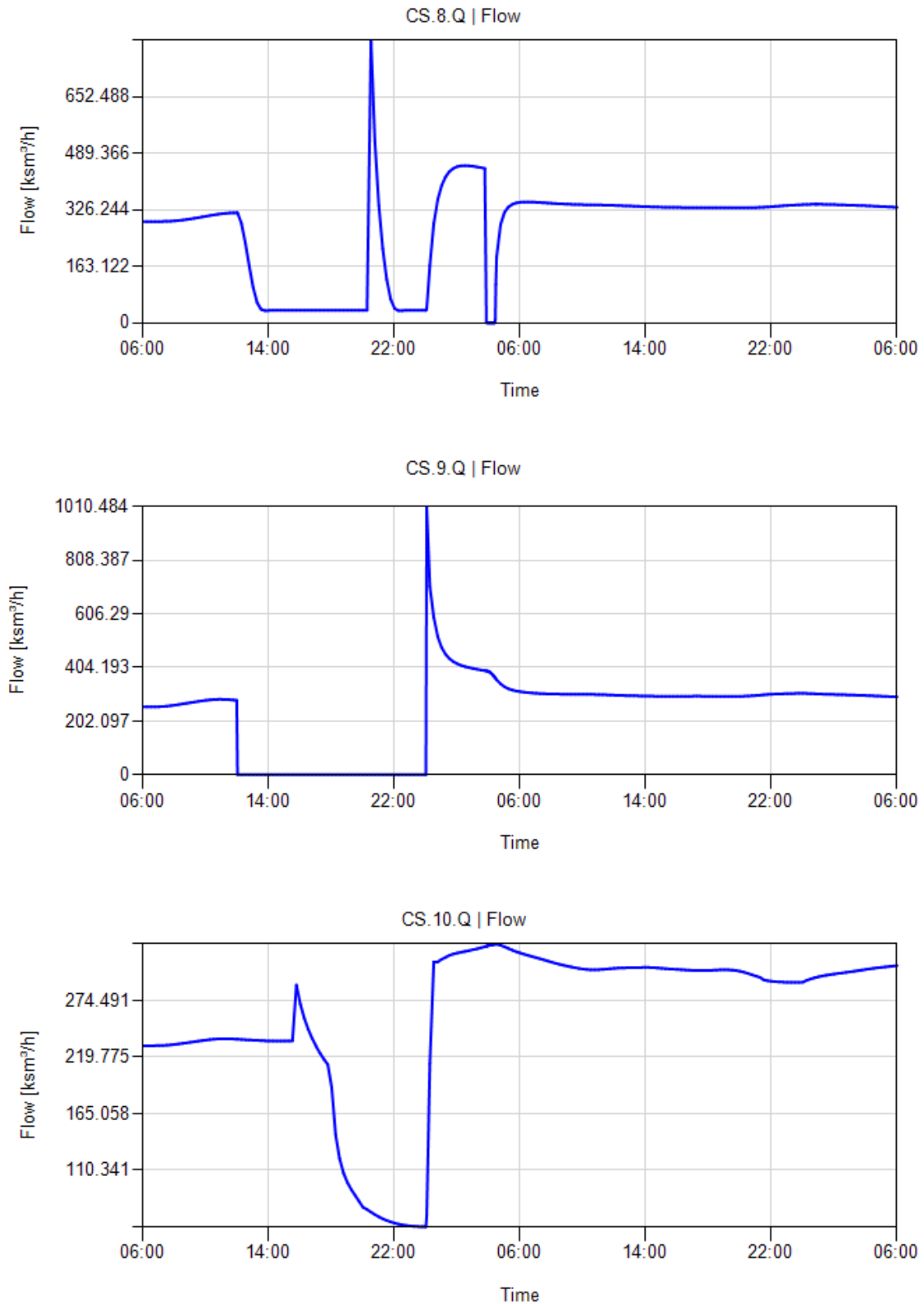

Fig. 14: Time series of of delivered gas quantity, station control, load and pressure for the Cross Border Import Negru Voda

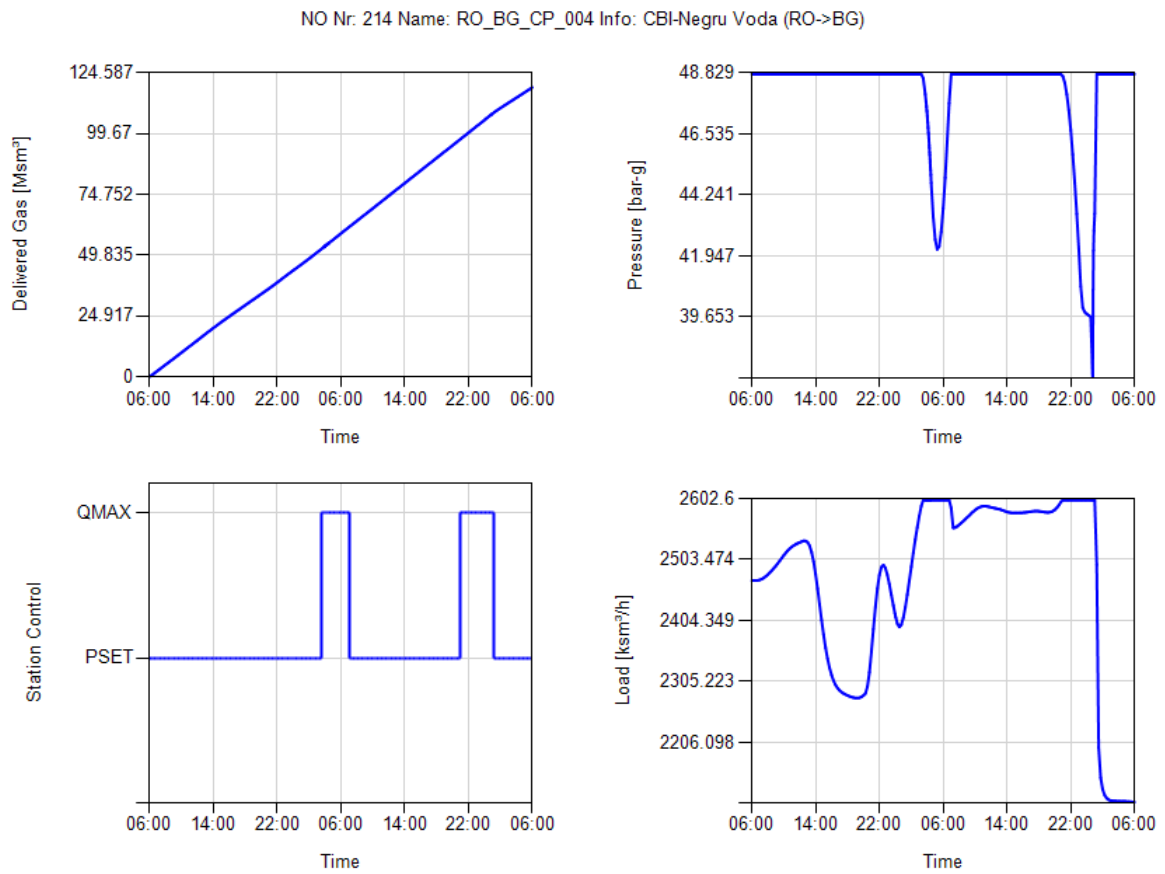

Fig. 15: Time series of of delivered gas quantity, station control, load and pressure for the Cross Border Import Kipi

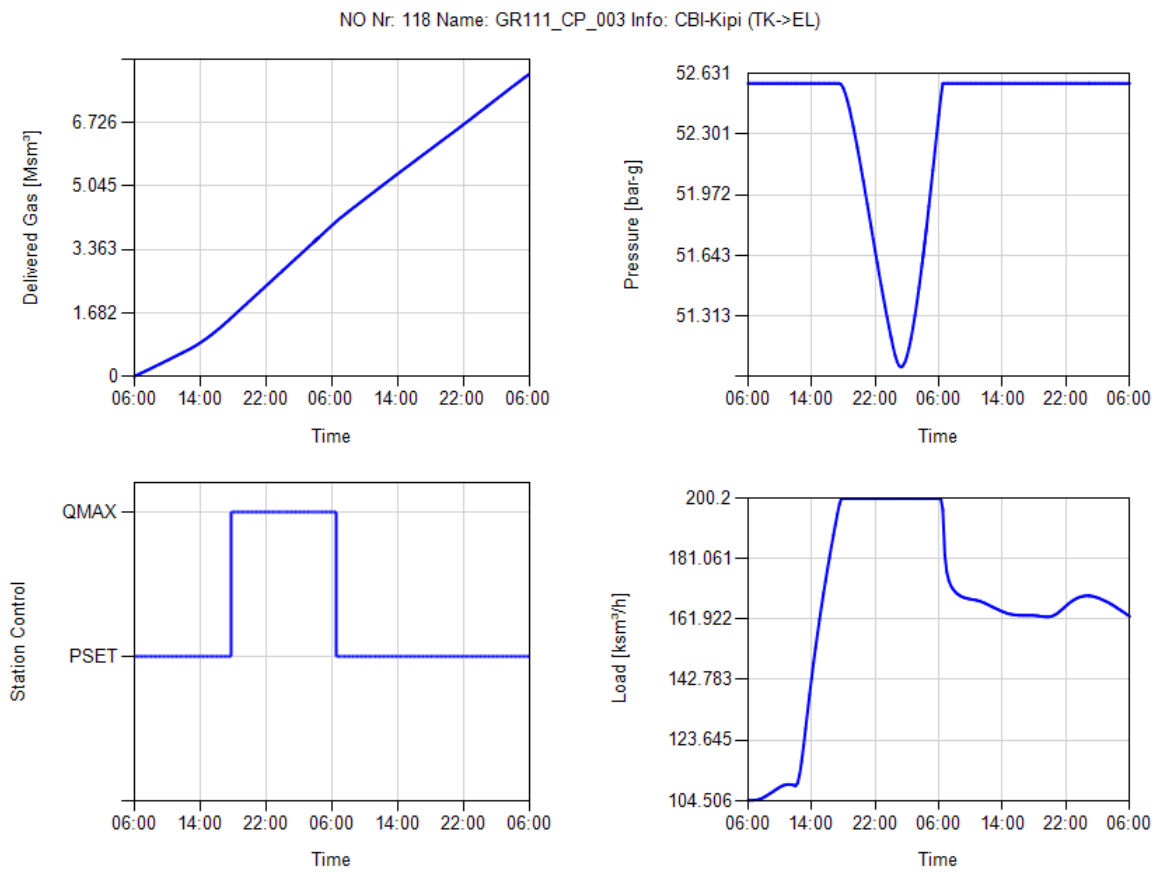

Fig. 16: Time series of of the supply, storage inventory, delivered gas quantity, station control, pressure and storage envelope for the Underground Gas Storage Facility Chiren

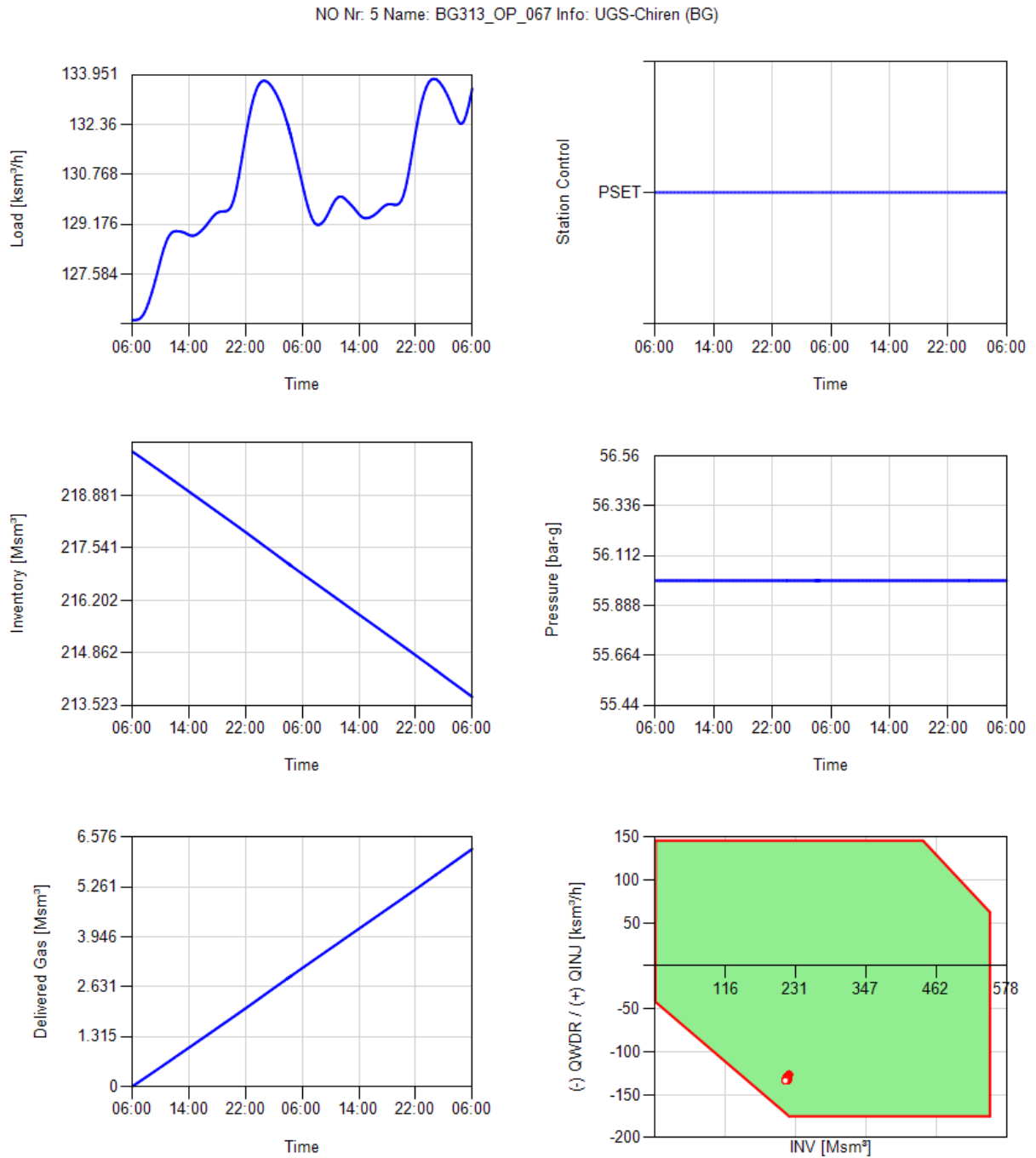

Fig. 17: Time series of the supply, storage inventory, delivered gas quantity, station control, pressure and storage envelope for the LNG-Terminal Revythoussa

