

University of Groningen

## Traffic to the inner membrane of the nuclear envelope

Laba, Justyna K.; Steen, Anton; Veenhoff, Liesbeth M.

*Published in:*  
Current Opinion in Cell Biology

*DOI:*  
[10.1016/j.ceb.2014.01.006](https://doi.org/10.1016/j.ceb.2014.01.006)

**IMPORTANT NOTE: You are advised to consult the publisher's version (publisher's PDF) if you wish to cite from it. Please check the document version below.**

*Document Version*  
Publisher's PDF, also known as Version of record

*Publication date:*  
2014

[Link to publication in University of Groningen/UMCG research database](#)

*Citation for published version (APA):*

Laba, J. K., Steen, A., & Veenhoff, L. M. (2014). Traffic to the inner membrane of the nuclear envelope. *Current Opinion in Cell Biology*, 28, 36-45. <https://doi.org/10.1016/j.ceb.2014.01.006>

### Copyright

Other than for strictly personal use, it is not permitted to download or to forward/distribute the text or part of it without the consent of the author(s) and/or copyright holder(s), unless the work is under an open content license (like Creative Commons).

The publication may also be distributed here under the terms of Article 25fa of the Dutch Copyright Act, indicated by the "Taverne" license. More information can be found on the University of Groningen website: <https://www.rug.nl/library/open-access/self-archiving-pure/taverne-amendment>.

### Take-down policy

If you believe that this document breaches copyright please contact us providing details, and we will remove access to the work immediately and investigate your claim.

*Downloaded from the University of Groningen/UMCG research database (Pure): <http://www.rug.nl/research/portal>. For technical reasons the number of authors shown on this cover page is limited to 10 maximum.*



ELSEVIER

# Traffic to the inner membrane of the nuclear envelope

Justyna K Laba<sup>1,2</sup>, Anton Steen<sup>1</sup> and Liesbeth M Veenhoff<sup>1,2</sup>

Past research has yielded valuable insight into the mechanisms that regulate the nuclear transport of soluble molecules like transcription factors and mRNA. Much less is known about the mechanisms responsible for the transportation of membrane proteins to the inner membrane of the nuclear envelope. The key question is: does the facilitated transport of integral inner membrane proteins exist in the same way as it does for soluble proteins and, if so, what is it used for? Herein, we provide an overview of the current knowledge on traffic to the inner nuclear membrane, and make a case that: (a) known sorting signals and molecular mechanisms in membrane protein biogenesis, membrane protein traffic and nuclear transport are also relevant with respect to INM traffic; and (b) the interplay of the effects of these signals and molecular mechanisms is what determines the rates of traffic to the INM.

## Addresses

<sup>1</sup>European Research Institute for the Biology of Ageing, University of Groningen, University Medical Center Groningen, Antonius Deusinglaan 1, 9713 AV Groningen, The Netherlands

<sup>2</sup>Netherlands Proteomics Centre, Groningen Biomolecular Sciences and Biotechnology Institute, University of Groningen, The Netherlands

Corresponding author: Veenhoff, Liesbeth M ([l.m.veenhoff@rug.nl](mailto:l.m.veenhoff@rug.nl))

Current Opinion in Cell Biology 2014, 28:36–45

This review comes from a themed issue on **Cell nucleus**

Edited by **Michael P Rout** and **Gary H Karpen**

For a complete overview see the [Issue](#) and the [Editorial](#)

Available online 13th February 2014

0955-0674 © 2014 The Authors. Published by Elsevier Ltd.

Open access under [CC BY-NC-ND license](#).

<http://dx.doi.org/10.1016/j.ceb.2014.01.006>

## Introduction

The nuclear envelope (NE) is a specialized area of the endoplasmic reticulum (ER). It is composed of two membranes, the inner and the outer nuclear membrane (INM and ONM), which come together in places where Nuclear Pore Complexes (NPCs) are embedded. In many eukaryotes, a proteinaceous surface, namely the nuclear lamina, underlies the INM. The perinuclear space in between the two membranes is continuous with the ER lumen. The ER, ONM and INM are also continuous, but have distinct functions and sets of transmembrane proteins. Assigning

proteins as true INM residents is problematical for multiple reasons, ranging from technical difficulties in microscopically resolving their localization in the INM or ONM, to biological reasons such as their cell type specificity [1]. Bioinformatic predictions are difficult to make, as only a few domains specific to INM proteins have been identified, such as the LEM (for Lap1-emerin-MAN1) and SUN (for Sad-Unc-84 homology) domains for which structures are available [2,3<sup>\*</sup>]. A decade ago, the first proteomic studies aimed at identifying putative INM proteins were performed [4,5] but to date, only a relatively small number of these proteins have been both well-characterized and proven to be enriched in the inner membrane compared to the outer membrane and ER.

The importance of the correct trafficking and function of INM proteins is clear from numerous examples of the roles played in the development of nuclear envelopopathies and cancer. Accordingly, the lamina-associated polypeptide 2, Lap2 $\beta$ , is over-expressed in digestive tract cancers [6]. Mutations in the lamin B receptor, LBR, cause both Greenberg dysplasia, a major disease leading to aberrant embryonic development [7], or Pelger-Huet anomaly [8]. Laminopathies are often linked to mutations in lamin A, but recent studies show that the mistargeting of INM proteins could be causative of the disease phenotypes [9<sup>\*</sup>,10]. For example, Hutchinson–Gilford Progeria Syndrome (HGPS), a serious accelerated ageing disease, is caused by a dominant *de novo* mutation in lamin A that results in the accumulation of progerin, which is a farnesylated lamin A variant. In HGPS cells, the levels of SUN1 in the INM are increased [9<sup>\*</sup>,11<sup>\*</sup>], and knocking-down SUN1 alleviates cellular senescence [9<sup>\*</sup>]. Similarly, nuclear deformation and cell survival are rescued by SUN1 knock-down in mice cells lacking lamin A or carrying progerin-like mutations [9<sup>\*</sup>].

Over the years, multiple mechanisms of INM protein targeting have been proposed, involving a variety of potential sorting signals. Earlier work suggested that the interplay between multiple signals is required for the efficient targeting of INM proteins [12,13]. Clearly, there will be multiple signals encoded on a specific membrane protein to guide its biogenesis and targeting. These signals may encode information for: insertion into the lipid bilayer, cytosolic subcellular sorting to the different membrane compartments, and nuclear transport. For each of these categories short descriptions of the molecular signals and mechanisms ('molecular toolboxes') are given (Fig. 1 and [Toolbox I, II and III](#)). [Table 1](#) contains an overview of some of the better studied integral membrane proteins that are enriched in the INM in *Saccharomyces cerevisiae* and

humans. We have also sorted into three molecular toolboxes the plethora of targeting information that has been experimentally validated.

### En route to the INM

#### *En route to the INM: membrane insertion*

Essential steps of the targeting process is the synthesis and insertion of the nascent polypeptide to the membrane environment (Fig. 1, I) [14]. The two conserved insertion machineries, the Sec61 and GET (Guided-Entry of TA proteins) systems, are situated in the ER, including the ONM. An INM localized pool of Sec61 might exist [15] and the GET transmembrane components are small and may also passively reach the INM through the lateral channels of the NPC. Thus, in principle a post-translational mechanism where a chaperoned INM protein is first trafficked to the nucleus, after which it is membrane inserted, could be possible for membrane proteins that are posttranslationally inserted such as very small monotopic membrane proteins and tail anchored proteins. However, this has not been tested directly.

Monotopic membrane proteins could be targeted at either of the two insertion machineries. From the proteins listed in Table 1, only emerin and LAP2 $\beta$  are potentially inserted via the GET pathway. The small splice variant of Heh1(-helix-extension-helix-1)/Src1 known as Src1-small, and Mps3 (monopolar spindle), SUN1 and SUN2 have larger

#### Toolbox I Protein insertion

Membrane protein integration into the lipid bilayer is a facilitated process. There are two well-characterized insertion systems that are conserved from yeast to man: the Sec61 system and the GET pathway (reviewed in [14,55,56]). The Sec61 system translocates soluble proteins and membrane proteins with single (monotopic) and multiple transmembrane spanning segments (polytopic). The current data supports that polytopic membrane proteins are inserted cotranslationally by the Sec61 system. The GET system evolved for the specialized post-translational insertion of tail anchored proteins, which are proteins with a single transmembrane spanning segment at their C-terminus and a short luminal tail. Small monotopic membrane proteins may also be inserted posttranslationally. Prediction of the topology of membrane proteins is based on hydrophobicity profiles and the characteristic features of the regions flanking the transmembrane segments. For example, if the region N-terminal of the transmembrane domain is long or positively charged (positive-inside rule), then it is likely extraluminal. The translocation of the N-terminus to the lumen is likely when positive charges are lacking, when the preceding region is not well folded and the hydrophobic sequence is long. Besides the Sec and GET pathways, other insertion machineries also exist, for example, in yeast, the Sec61 homolog, Ssh1, and the Sec63 complex.

The question of post-translational or co-translational insertion could be relevant to traffic of INM proteins, but has been little studied. In particular post-translational insertion via the GET pathway could occur at the INM post nuclear import, in which case the transport occurs as a soluble chaperoned protein.

#### Toolbox II Cytosolic subcellular traffic

In general, membrane proteins may traffic through different subcellular compartments before they reach their destination, for example to be modified post-translationally. In addition, membrane proteomes are generally dynamic, for example there is a rapid exchange between the plasma membrane, pools of vesicles and the ER network. For the trafficking of membrane proteins to the different cellular membranes, signal sequences exist such as those for Golgi retrieval, ER retention, and peroxisome and mitochondrial targeting. The localization of a protein encoding multiple signals depends on the kinetics of the different trafficking routes.

It may be a mistake to think of INM proteins as stable components of the INM; they may well also have a dynamic localization within the cell that is regulated by the interplay of the above sorting signals. Cases where cytosolic subcellular traffic is relevant for traffic of INM proteins are given in Table 1.

luminal domains and their insertion is probably facilitated by the Sec61 system. The polytopic membrane proteins, Heh1/Src1, Heh2 (helix-extension-helix-1), LEM2 (Lap1-emerin-MAN1-2), MAN1, LBR and nurim, are probably inserted by Sec61 co-translationally.

#### Toolbox III Nuclear import

The NPCs are anchored where both the INM and ONM come together to form the highly curved pore membrane. Their overall architecture and function is broadly conserved from yeast to humans. There are also distinct differences between yeast and metazoan NPCs: the yeast NPCs are smaller in size and molecular weight and each of them has several unique components [57,58]. NPCs are composed of a scaffold of folded proteins that anchor the 8-fold rotational symmetric structure to the nuclear envelope membrane. A set of intrinsically disordered proteins, the FG-Nups, are anchored to the scaffold of the NPC, and are critical for the selectivity of the pore. For soluble proteins, the mechanisms of nuclear transport are well described [59]. Molecules may diffuse through the NPC passively (efflux/influx) and equilibrate between the cytosol and nucleus. Transport factors and the gradient of RanGTP–RanGDP across the nuclear envelope are required to specifically ‘pump’ proteins against a concentration gradient and to transport very large macromolecular complexes across the NPC. In these facilitated import and export reactions, soluble transport factors shuttle Nuclear Localization Signal (NLS)-containing proteins or Nuclear Export Signal (NES)-containing proteins across the NPCs. The FG-Nups encode multiple phenylalanine and glycine (FG)-repeats that act as binding sites for the soluble transport factors. Direction to the transport reaction is given by the gradient of RanGTP–RanGDP across the nuclear envelope: in an import reaction, the transport factor dissociates from cargo in the presence of RanGTP, thereby releasing the cargo in the nucleus. In addition, retention mechanisms usually play a role in defining nuclear and cytosolic concentrations of soluble proteins.

Retention mechanisms also play a major role in defining INM localization of membrane proteins. In addition, specifically in yeast, there is good evidence for the facilitated import of Heh1 and Heh2 resulting in accumulation in the INM. Alike for soluble proteins, traffic of these INM proteins depends on FG-Nups, Kaps and the gradient of RanGTP–RanGDP. The sorting signal is composed of an NLS and a long intrinsically disordered linker.

Figure 1

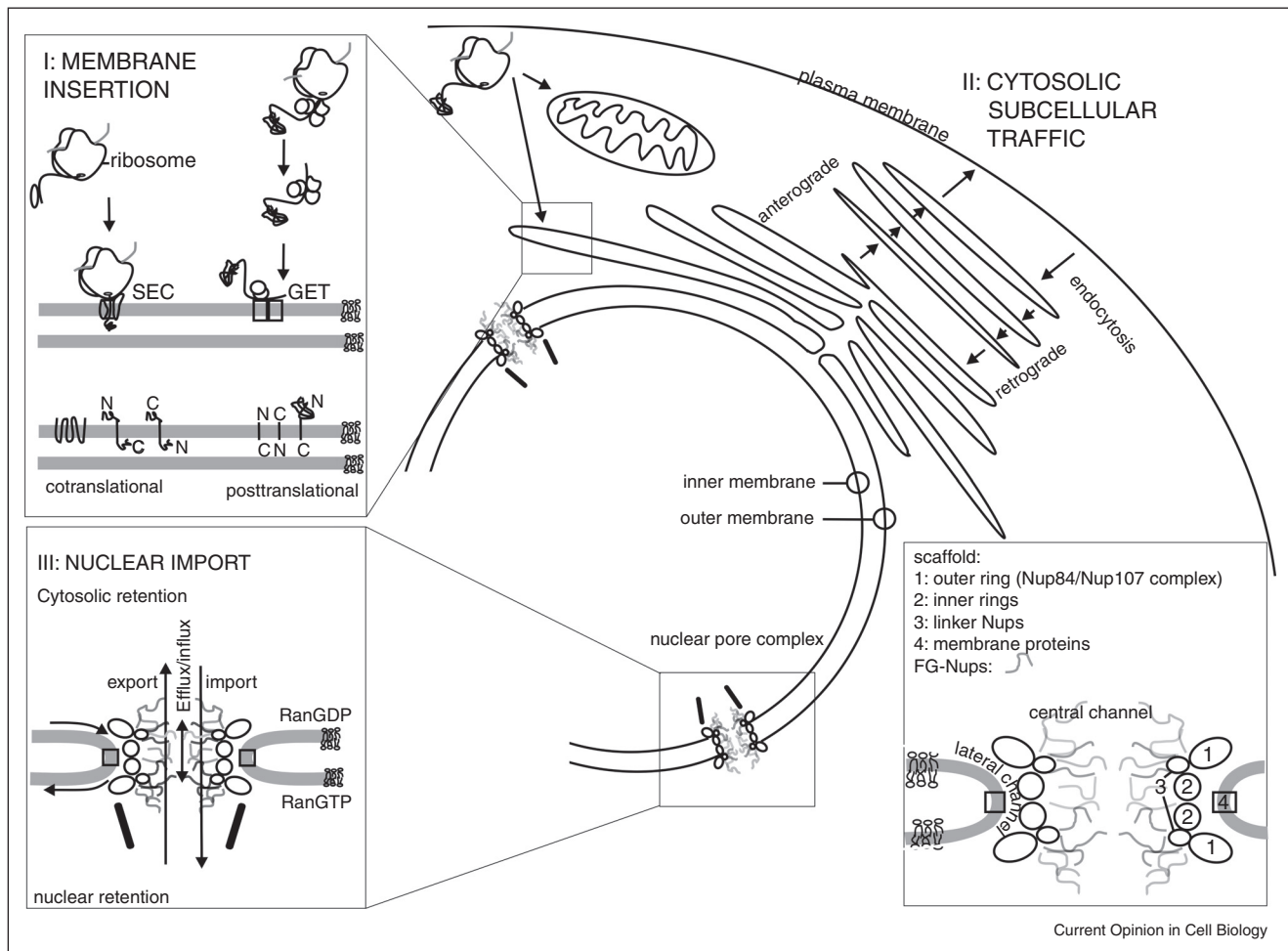

The sorting of integral inner membrane proteins is an add-up of known principles of membrane protein biogenesis, cytosolic subcellular traffic and nuclear transport. See toolbox I, II, III for explanation.

Many INM proteins have relatively large N-terminal extraluminal domains, which often contain regions that have been proved to be relevant for trafficking (Fig. 2). The early recognition of INM proteins, including as early as during translation, was first proposed for viral peptides and later for native INM proteins [16–18]. Here, a shorter isoform of importin- $\alpha$  was shown to both bind a nascent polypeptide chain predisposed for the INM at a stretch of positive charges located 5–8 residues from the transmembrane segment, and direct it to the translocon [16–18]. Whether this is a significant sorting event specifically in Heh2 is unclear, as the absence of this sequence does not affect localization [19]. Accordingly, instead of a sorting sequence, this could be regarded as a manifestation of the positive inside rule guiding membrane insertion. We take that the early recognition of Heh2, being destined for the INM, is more likely to occur through the early binding of the yeast homolog of importin- $\alpha$ , Kap60, to the exceptionally strong NLS of Heh2 [20\*].

#### *En route to the INM: cytosolic subcellular sorting*

The localization of a protein encoding multiple signals depends on the kinetics of the different trafficking routes. Anything that disrupts this balance can cause a change in localization. For example, mitochondria have a separate system for tail anchored protein insertion that could potentially compete with the GET system inserting them into the ER [21]. Knowledge of the cytosolic subcellular sorting (Fig. 1, II) of integral INM proteins is thus far limited, but SUN2 is a clear example of how elements of subcellular sorting between the ER and Golgi are important. This monotopic INM protein possesses an Arg-rich Golgi retrieval signal that is necessary for its INM localization [12]. Similar Arg-rich sequences are found in LBR, Lap2 $\beta$ , emerin and LEM2, but their involvement in targeting has not yet been characterized.

Changes in the concentrations of interaction partners can also disturb proper sorting. For instance, SUN2 was found

in endosomes when Rab5, a small GTPase responsible for endosomal membrane fusion and complexing SUN2, was over-expressed [22]. Another example is the mislocalization of SUN1 to the Golgi that has been observed in mice lacking functional wild-type lamin A [9<sup>•</sup>]. Lamin A is probably needed for the retention of SUN1, preventing it from travelling to the Golgi. Indeed, when the N-terminal lamin A-interacting domain of SUN1 is deleted, the SUN1 relocates from the NE to the Golgi [9<sup>•</sup>]. A balance between subcellular localizations is also required for LBR, which has two separate functions: inside the nucleus it is responsible for regulating the structure of the NE, as illustrated by its role in maintaining the lobulated structure of granulocyte nuclei [8], but it also acts as a sterol reductase for which it has to be ER localized [7]. How the dual localization is controlled is presently unclear.

Intriguing connections with plasma membrane localization also exist. Emerin, for instance, targets to the plasma membrane in the heart tissue of some animals [23]. Also interesting is how the epidermal growth factor receptor (EGFR) travels from the plasma membrane to the nucleus upon EGF binding. The receptor is endocytosed and travels through the Golgi and to the ER via COPI regulated retrograde vesicle trafficking [24,25]. The next steps include translocation to the nucleus and extraction from the membrane, although the order in which this happens is unclear, nor is what triggers membrane extraction.

#### *En route to the INM: nuclear import*

Current models of the transport of INM proteins disagree significantly on the nature of energy dependence: is there or is there not an active energy dependent import that drives the accumulation of membrane proteins in the INM? When looking at soluble proteins like transcription factors, we mostly see that retention mechanisms, as well as the kinetics of import, export, influx and efflux, define their localization (Fig. 1, III). These kinetics can be adapted by modification or the shielding of import and export signals.

Many membrane proteins in the INM are retained due to interactions with nuclear components, most notably lamins and chromatin and SUN-KASH interactions in the lumen, but there is now good evidence that this 'selective retention' is not the sole basis for their nuclear presence. An initial report on the energy (and temperature) dependence of INM protein import [26] suggested that ATP is used for NPC restructuring which creates transient channels through which the proteins could travel. Later reports show that several INM proteins make direct or indirect use of the classical nuclear transport elements, including NLSs, Kaps and FG-Nups. *S. cerevisiae* Heh1 and Heh2 and human SUN2 have confirmed NLS sequences [12,27], while others have predicted sequences [28]. Moreover, Heh1 and Heh2

localization is dependent on the transport factors Kap60 and Kap95 (yeast importin- $\beta$ ), the RanGTP/RanGDP gradient, and a subset of FG-Nups [19,27]. In *S. cerevisiae*, a combination of an NLS and an intrinsically disordered (ID) linker (L) is required *and is sufficient* for INM targeting. This 'NLS-L' motif targets a Heh2 transmembrane domain, a polytopic Sec61 transmembrane domain and a synthetic transmembrane domain composed of leucine alanine repeats to the INM. We propose that the ID linker facilitates binding to the transport factors and interactions with the FG-Nups [19,29]. Alternatively, or additionally, the combination of the strong NLS and the ID linker acts earlier in the membrane protein biogenesis or traffic. Consistent with a facilitated transport mechanism, large extraluminal domains are tolerated [20<sup>•</sup>]. However, more importantly, using these mobile proteins it was shown that, upon blocking import, the protein leaks out from the INM to the ER. This demonstrates that INM accumulation is the result of fast import and slower efflux, and reflects energy driven accumulation. Facilitated NLS mediated import of proteins with large extraluminal domains has been reproduced with polytopic transmembrane proteins, which should resolve the discussion of whether the transmembrane segments are embedded in the membrane during transport (unpublished). Having reinforced the aspect of the facilitated transport of these yeast INM proteins, we emphasize that retention also plays a role. Full length Heh1 and Heh2 have LEM domains, and their diffusion in the membrane is much slower than that of truncated versions without the LEM domain. This is consistent with them binding to nuclear structures [19]. Overall, as for soluble proteins, the localization of these INM proteins is defined by the kinetics of import, leakage and nuclear retention.

For INM proteins without predicted NLS sequences, other mechanisms for facilitated transport have been proposed, for example via FG repeats encoded on the INM proteins [30], or via a piggyback mechanism in which membrane proteins bind to a soluble NLS-containing protein. The latter mode of transport was proposed for Mps3, which binds histone H2Z.A [31]. Some of the INM proteins that are thought to localize due to retention may in fact make use of the piggyback import. Lamins come to mind as potential piggyback candidates. The current thinking is that lamins contribute to sorting by retaining INM proteins upon arrival at the INM, but a role in piggyback transport of INM proteins cannot be excluded until we measure where they first associate. For example, prelamin A may have such a role in targeting of SUN1 to the INM. In differentiating human myoblasts, farnesylated prelamin A accumulates in and recruits SUN1 to the NE [32]. Additionally, a type of lamin A, possibly the unprocessed or mature forms, prevents SUN1 from travelling to the Golgi [9<sup>•</sup>]. Farnesylated prelamin A also interplays with SUN2 targeting in differentiating



Figure 2

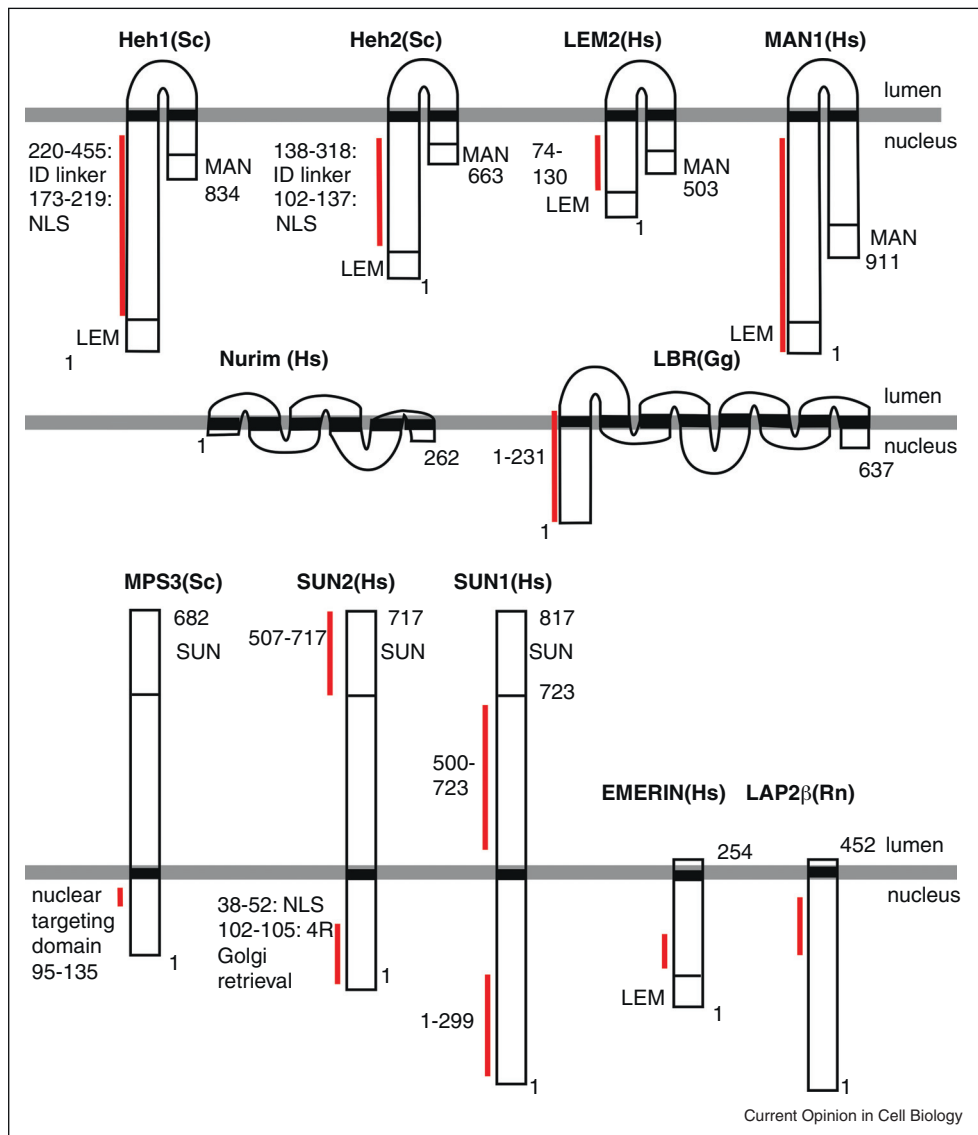

Targeting signals in integral membrane proteins of the inner membrane of the nuclear envelope. The topology of some of the better studied integral membrane proteins of the INM. The red bar indicates part of the sequence that was shown experimentally to be important for the INM localization of the protein (references in Table 1). LEM (for Lap1-emerin-MAN1), MAN (Heh/Man1 carboxy-terminal homology domain, CTHD) and SUN (for Sad-Unc-84 homology) domains are indicated. Hs *Homo sapiens*, Sc, *Saccharomyces cerevisiae*, Rn *Rattus norvegicus*, Gg *Gallus gallus*.

myoblasts. Here, the enrichment of SUN2 at the nuclear poles depends on farnesylated prelamin A [32]. Moreover, in patients with Mandibuloacral dysplasia with type A lipodystrophy (MADA), which is a rare disease caused by the accumulation of unprocessed prelamin A, SUN2 distribution in the NE is disorganized. This is rescued by drugs that reduce prelamin A farnesylation [10].

In conclusion, particularly in yeast, there is good evidence for the facilitated import of membrane proteins that results in accumulation in the INM. In human cells, there

is no definitive answer as to whether facilitated transport alone can result in accumulation in the INM. Nevertheless, it is clear that retention mechanisms play a major role in both yeast and mammalian systems.

#### Putative NPC independent traffic

As discussed [33], NPC independent routes across the NE, such as those used by viruses [34], may also be available to traffic native membrane proteins. For the replication of the Herpes Simplex virus, large nucleocapsids are formed in the nucleus, which have to pass the NE before their

**Table 1****Sorting signals in integral INM proteins.**

Protein	Toolbox I elements: membrane protein insertion	Toolbox II elements: cytosolic protein sorting	Toolbox III elements: nuclear import machinery	Unclassified	Refs.
<i>Yeast</i>					
Mps3	Cotranslational Sec61 system <sup>a</sup>		- Indirect dependence on Kap123, Kap95 and RanGTP–RanGDP gradient; piggyback mechanism via binding to histone H2Z.A. - Nuclear retention		[31,60]
Heh1/Src1	- Src1 small: cotranslational Sec61 <sup>a</sup> - Full length Heh1: cotranslational Sec61 <sup>a</sup>		- NLS, RanGTP–RanGDP gradient, Kap60, Kap95, Nup170, Nup2 - Nuclear retention		[19,27]
Heh2	- Cotranslational Sec61 <sup>a</sup> ; - We interpret 'INM sorting motif' is topology indicator		- NLS, RanGTP–RanGDP gradient, Kap60, Kap95, Nup170, Nup2, GLFG domains of Nup100, Nup57, Nup145 - Nuclear retention		[17,19,27]
<i>Human</i>					
SUN1	Cotranslational Sec61 <sup>a</sup>		- Nuclear retention	Localization depends on farnesylated prelamin A	[11*,32,61]
SUN2	Cotranslational Sec61 <sup>a</sup>	Golgi retrieval signal	- NLS, importin- $\alpha$ , importin- $\beta$ , RanGTP–RanGDP gradient, - Nuclear retention	SUN2 mobility requires ATP	[12,22,62,63]
Emerin	Tail anchored protein, possibly posttranslational insertion by GET pathway <sup>a</sup>	Subpopulation in plasma membrane in heart tissue from human, rat and mouse (sorting signals unknown)	- Nuclear retention	Emerin mobility requires ATP	[23,63]
LAP2 $\beta$	Tail anchored protein, possibly posttranslational insertion by GET pathway <sup>a</sup>		- Nuclear retention		[26,64–66]
LEM2	Cotranslational Sec61 <sup>a</sup>		- Nuclear retention		[67]
MAN1	Cotranslational Sec61 <sup>a</sup>		- Nuclear retention		[68]
LBR	- Cotranslational Sec61 <sup>a</sup> - N terminal domain probably co-defines topology; - 'INM sorting motif'	Distinct functions at ER and NE (sorting signals unknown)	- RanGTP dependent interaction with Importin $\beta$ (not importin- $\alpha$ dependent) - Nuclear retention	Mobility of LBR is dependent on RanGTP and Nup35	[7,16,63, 69–72]
Nurim	- Cotranslational Sec61 <sup>a</sup> - 'INM sorting motif'		- Nuclear retention (but not to DNA and not to lamins)		[73,74]

<sup>a</sup> Prediction.

maturation in the cytosol. An NPC independent export model, namely nuclear egress, is currently accepted as an explanation for this phenomenon (reviewed in [35]). The nuclear localized capsids are enveloped by the INM and cross the perinuclear space as vesicles, which fuse with the ONM and release the capsid to the cytoplasm. The same mechanism is reported in *Drosophila melanogaster* for the export of ribonucleoprotein particles (RNPs), which are too large to pass the NPC [36\*]. Perinuclear granules have been observed in other cell types and species, so the nuclear egress might in fact be a conserved export mechanism.

Nuclear egress has been hypothesized to be involved in the removal of nuclear protein aggregates [37]. Future studies will have to demonstrate if membrane proteins could exit the nucleus via any such egress pathway.

### Challenges when studying INM import

#### Kinetics matter

Definitive proof of the existence of the facilitated transport of membrane proteins requires verification that import across the NPC is faster than efflux, as well as a demonstration that import is transport factor and Ran

dependent. This requires methods that allow the direct assessment of transport kinetics through the NPC, distinct from the kinetics of diffusion in the INM and ONM. Single molecule tracking experiments would be uniquely suitable, but are thus far unexploited.

Alternatively, it is possible to measure rates of bulk efflux or bulk import. Bulk efflux is measured in experiments that start with an accumulation in the INM and then follow the kinetics of equilibration after blocking facilitated import. The steady state accumulation levels together with the efflux kinetics reveal the kinetics of import. These measurements can only be obtained when the proteins of interest are freely diffusing and are not retained in either compartment. The absence of protein turnover over the measured time period is also critical. However, for all known INM proteins, the binding of nuclear localized proteins is an important retention mechanism which makes them unsuitable for bulk efflux measurements. As a consequence, truncated versions that lack retention signals, or even synthetic constructs encoding only the minimally required sorting signals [19,20<sup>\*</sup>], must be used for these studies.

#### *Where do membrane proteins travel through the NPC?*

Based on electron tomographs of metazoan NPCs [38–41], the most logical pathway of the extraluminal domains of INM proteins is along the pore membrane through the lateral channels (Fig. 1). These channels are flanked on the cytoplasmic and nuclear sides by the proteins from the outer ring Y-shaped Nup84 or Nup107 subcomplexes in yeast and humans, respectively [42]. An approximately 10 nm space is available between the membrane and this part of the NPC scaffold. More centrally in the NPC, the lateral channels are flanked by its integral membrane proteins, and here the passage seems to be more restricted. Unfortunately, high resolution tomographs are not available of *S. cerevisiae*.

Membrane proteins have been proposed as passing through (a) the lateral channels, which seems likely judging from the tomographic images of NPCs, or (b) the central channel, which is likely considering the involvement of FG-Nups and Kaps. Three main uncertainties about the structure of the NPC are relevant here. Firstly, yeast and human pores may differ critically, and whereas (a) is largely supported by work regarding metazoans, (b) is mostly from work with respect to baker's yeast. Secondly, whether the disordered FG-Nups occupy the space in the lateral channels, and whether FG-Nups facilitate karyopherin mediated traffic through the lateral channels, is unknown. Thirdly, NPCs are flexible structures in which the position of the 8-fold rotational symmetric units is variable [39]. At the impressive but still limited resolution available, it is uncertain whether small or temporary openings exist between the centre of the NPC and the lateral channels. Accordingly,

to resolve the route(s) through the NPC (even) better knowledge of its dynamic structure is required.

#### **Why INM targeting would be needed**

Recent studies have uncovered new exciting functions of integral membrane proteins residing in the INM, and while for some of these activities passive diffusion and selective retention is sufficient, for others a tighter control of protein localization could be expected. Passive diffusion may be enough for LAP2 $\beta$  and MAN1, which have been shown to (redundantly) mediate the assembly of the NE [43]. High enrichment in the INM may possibly be required for proteins that play a role in NPC assembly into an intact NE. NPC assembly in the intact NE in yeast depends on Heh1 and Heh2 [44], while Sun1 and an INM-localized pool of Pom121 play a role in NPC assembly in humans [45–49]. INM proteins can also directly contribute to the INM acting as a 'transcription factor resting place' by sequestering transcription factors that illegitimately entered the nucleus and as such prevent transcription of target genes [50].

Functions related to chromatin anchoring to the nuclear periphery might depend on facilitated transport, as they require a higher level of regulation (recent reviews [51,52]). An analysis of cells with inverted chromatin architecture has provided interesting insights into this topic [53<sup>\*\*</sup>]. The heterochromatin of rod photoreceptor cells of nocturnal mammals is not located on the nuclear periphery, but is shifted to the nuclear interior. This phenotype occurs gradually during differentiation and is caused by the lack of the anchoring proteins LBR and lamin A/C in mature cells, whereas LBR is still present in the cells at early stages of differentiation. This sequential expression of the above-mentioned proteins during differentiation has also been observed in different mouse tissues, and has a potential effect on the expression of cell type specific genes. The deletion of LBR or lamin A in differentiating myotubes have the opposite effects: a lack of LBR increases the expression of muscle specific genes, while the loss of lamin A reduces it. There is no LBR or lamin A regulated effect on the expression level of the same genes in mature muscle cells. These results suggest that INM proteins act as heterochromatin tethers to regulate differentiation. Indeed, several INM proteins are able to reposition specific chromosomes and are restricted to certain tissues [54<sup>\*</sup>].

These observations strongly support the idea that INM proteins localize in the nucleus specifically to shape chromatin and regulate transcription, and do not enter the nucleus by chance and stay there due to an interaction with DNA. So, in addition to the regulation of the expression or turnover of INM proteins, facilitated import may also play an important role in tuning the



proteome of the inner membrane, and with that the proteome of the cell.

### Concluding remarks

We asked the question as to whether the facilitated transport of integral inner membrane proteins exists in the same way as it does for soluble proteins, and, if so, what is it used for. We conclude that there is ample evidence that the facilitated import of integral membrane proteins exists in *S. cerevisiae*. Some may argue that facilitated import in yeast is a consequence of its closed mitosis and lack of lamins. However, the biological evidence of INM proteins directing chromosome localization and transcriptional regulation, as well as the presence of NLS sequences, suggests that facilitated transport is also present in humans. A better understanding of the transport of integral membrane proteins to the INM should go hand in hand with research aimed at uncovering new roles of INM proteins in chromatin organization and signal transduction in development, ageing and differentiation.

### Acknowledgements

We are grateful to Patrick Lusk for his valuable discussions. This work is financed by the research programmes NWO-vidi and ECHO from the Netherlands Organization for Scientific Research (NWO) and by the Netherlands Proteomics Centre.

### References and recommended reading

Papers of particular interest, published within the period of review, have been highlighted as:

- of special interest
- of outstanding interest

1. Ias Heras de JI, Meinke P, Batrakou DG, Srsen V, Zuleger N, Kerr AR, Schirmer EC: **Tissue specificity in the nuclear envelope supports its functional complexity.** *Nucleus* 2013:4.
2. Laguri C, Gilquin B, Wolff N, Romi-Lebrun R, Courchay K, Callebaut I, Worman HJ, Zinn-Justin S: **Structural characterization of the LEM motif common to three human inner nuclear membrane proteins.** *Struct Fold Des* 2001, **9**:503-511.
3. Sosa BA, Rothballer A, Kutay U, Schwartz TU: **LINC complexes form by binding of three KASH peptides to domain interfaces of trimeric SUN proteins.** *Cell* 2012, **149**:1035-1047.
- The SUN domain is one of the few INM protein specific domains identified, and this paper presents its crystal structure, in complex with KASH. The structure shows a hexameric arrangement of three SUN and three KASH domains.
4. Dreger M, Bengtsson L, Schöneberg T, Otto H, Hucho F: **Nuclear envelope proteomics: novel integral membrane proteins of the inner nuclear membrane.** *Proc Natl Acad Sci U S A* 2001, **98**:11943-11948.
5. Schirmer EC, Florens L, Guan T, Yates JR III, Gerace L: **Nuclear membrane proteins with potential disease links found by subtractive proteomics.** *Science* 2003, **301**:1380-1382.
6. Kim H-J, Hwang S-H, Han M-E, Baek S, Sim H-E, Yoon S, Baek S-Y, Kim B-S, Kim J-H, Kim S-Y *et al.*: **LAP2 is widely overexpressed in diverse digestive tract cancers and regulates motility of cancer cells.** *PLoS ONE* 2012, **7**:e39482.
7. Clayton P, Fischer B, Mann A, Mansour S, Rossier E, Veen M, Lang C, Baasanjav S, Kieslich M, Brossuleit K *et al.*: **Mutations causing Greenberg dysplasia but not Pelger anomaly uncouple enzymatic from structural functions of a nuclear membrane protein.** *Nucleus* 2010, **1**:354-366.
8. Hoffmann K, Dreger CK, Olins AL, Olins DE, Shultz LD, Lucke B, Karl H, Kaps R, Müller D, Vaya A *et al.*: **Mutations in the gene encoding the lamin B receptor produce an altered nuclear morphology in granulocytes (Pelger-Huët anomaly).** *Nat Genet* 2002, **31**:410-414.
9. Chen C-Y, Chi Y-H, Motalif RA, Starost MF, Myers TG, Anderson SA, Stewart CL, Jeang K-T: **Accumulation of the inner nuclear envelope protein Sun1 is pathogenic in progeric and dystrophic laminopathies.** *Cell* 2012, **149**:565-577.
- This study shows the pathology of upregulation and Golgi targeting of SUN1, when Lamin A is mutated or lacking. Knocking down SUN1 in HGPS cells and mutant Lamin A mouse models, rescues the cells from nuclear deformations and senescence.
10. Camozzi D, D'Apice MR, Schena E, Cenni V, Columbaro M, Capanni C, Maraldi NM, Squarzoni S, Ortolani M, Novelli G *et al.*: **Altered chromatin organization and SUN2 localization in mandibuloacral dysplasia are rescued by drug treatment.** *Histochem Cell Biol* 2012, **138**:643-651.
11. Haque F, Mazzeo D, Patel JT, Smallwood DT, Ellis JA, Shanahan CM, Shackleton S: **Mammalian SUN protein interaction networks at the inner nuclear membrane and their role in laminopathy disease processes.** *J Biol Chem* 2010, **285**:3487-3498.
- Some lamin A mutations, associated with laminopathies as Emery–Dreifuss muscular dystrophy and Hutchinson–Gilford Progeria Syndrome (HGPS), disrupt interactions with SUN1 and SUN2. SUN1 is accumulated at the NE in HGPS cells, which correlates with Prelamin A accumulation.
12. Turgay Y, Ungricht R, Rothballer A, Kiss A, Csucs G, Horvath P, Kutay U: **A classical NLS and the SUN domain contribute to the targeting of SUN2 to the INM.** *EMBO J* 2010:119 <http://dx.doi.org/10.1038/emboj.2010>.
13. Tapley EC, Ly N, Starr DA: **Multiple mechanisms actively target the SUN protein UNC-84 to the inner nuclear membrane.** *Mol Biol Cell* 2011, **22**:1739-1752.
14. Shao S, Hegde RS: **Membrane protein insertion at the endoplasmic reticulum.** *Annu Rev Cell Dev Biol* 2011, **27**:25-56.
15. Deng M, Hochstrasser M: **Spatially regulated ubiquitin ligation by an ER/nuclear membrane ligase.** *Nature* 2006, **443**:827-831.
16. Braunagel SC, Williamson ST, Ding Q, Wu X, Summers MD: **Early sorting of inner nuclear membrane proteins is conserved.** *Proc Natl Acad Sci U S A* 2007, **104**:9307-9312.
17. Liu D, Wu X, Summers MD, Lee A, Ryan KJ, Braunagel SC: **Truncated isoforms of Kap60 facilitate trafficking of Heh2 to the nuclear envelope.** *Traffic* 2010, **11**:1506-1518.
18. Saksena S, Shao Y, Braunagel SC, Summers MD, Johnson AE: **Cotranslational integration and initial sorting at the endoplasmic reticulum translocon of proteins destined for the inner nuclear membrane.** *Proc Natl Acad Sci U S A* 2004, **101**:12537-12542.
19. Meinema AC, Laba JK, Hapsari RA, Otten R, Mulder FAA, Kraft A, van den Bogaart G, Lusk CP, Poolman B, Veenhoff LM: **Long unfolded linkers facilitate membrane protein import through the nuclear pore complex.** *Science* 2011, **333**:90-93.
20. Meinema AC, Poolman B, Veenhoff LM: **Quantitative analysis of membrane protein transport across the nuclear pore complex.** *Traffic* 2013, **14**:487-501.
- A quantitative analysis of karyopherin-mediated import and passive efflux of Heh2 derived reporters and their mobility in different membrane compartments is presented. Membrane proteins with large extraluminal domains terminal to the intrinsically disordered linker passively leak out from the INM to the ONM and ER.
21. Wattenberg B, Lithgow T: **Targeting of C-terminal (tail)-anchored proteins: understanding how cytoplasmic activities are anchored to intracellular membranes.** *Traffic* 2001, **2**:66-71.
22. Liang Y, Chiu PH, Yip KY, Chan SY: **Subcellular localization of SUN2 is regulated by lamin A and Rab5.** *PLoS ONE* 2011, **6**:e20507.
23. Berk JM, Tiftt KE, Wilson KL: **The nuclear envelope LEM-domain protein emerin.** *Nucleus* 2013, **4**:298-314.

24. Du Y, Shen J, Hsu JL, Han Z, Hsu M-C, Yang C-C, Kuo H-P, Wang YN, Yamaguchi H, Miller SA *et al.*: **Syntaxin 6-mediated Golgi translocation plays an important role in nuclear functions of EGFR through microtubule-dependent trafficking.** *Oncogene* 2013;1 <http://dx.doi.org/10.1038/onc.2013>.
25. Wang Y-N, Wang H, Yamaguchi H, Lee H-J, Lee H-H, Hung M-C: **COPI-mediated retrograde trafficking from the Golgi to the ER regulates EGFR nuclear transport.** *Biochem Biophys Res Commun* 2010, **399**:498-504.
26. Ohba T, Schirmer EC, Nishimoto T, Gerace L: **Energy- and temperature-dependent transport of integral proteins to the inner nuclear membrane via the nuclear pore.** *J Cell Biol* 2004, **167**:1051-1062.
27. King MC, Patrick Lusk C, Blobel G: **Karyopherin-mediated import of integral inner nuclear membrane proteins.** *Nature* 2006, **442**:1003-1007.
28. Lusk CP, Blobel G, King MC: **Highway to the inner nuclear membrane: rules for the road.** *Nat Rev Mol Cell Biol* 2007, **8**: 414-420.
29. Meinema AC, Poolman B, Veenhoff LM: **The transport of integral membrane proteins across the nuclear pore complex.** *Nucleus* 2012, **3**:322-329.
30. Kerr AR, Schirmer EC: **FG repeats facilitate integral protein trafficking to the inner nuclear membrane.** *Commun Integr Biol* 2011, **4**:557-559.
31. Gardner JM, Smoyer CJ, Stensrud ES, Alexander R, Gogol M, Wiegraebe W, Jaspersen SL: **Targeting of the SUN protein Mps3 to the inner nuclear membrane by the histone variant H2A.Z.** *J Cell Biol* 2011, **193**:489-507.
32. Mattioli E, Columbaro M, Capanni C, Maraldi NM, Cenni V, Scotlandi K, Marino MT, Merlini L, Squarzoni S, Lattanzi G: **Prelamin A mediated recruitment of sun1 to the nuclear envelope directs nuclear positioning in human muscle.** *Cell Death Differ* 2011, **18**:1305-1315.
33. Burns LT, Wente SR: **Trafficking to uncharted territory of the nuclear envelope.** *Curr Opin Cell Biol* 2012, **24**:341-349.
34. Kobiler O, Drayman N, Butin-Israeli V, Oppenheim A: **Virus strategies for passing the nuclear envelope barrier.** *Nucleus* 2012, **3**:526-539.
35. Mettenleiter TC, Müller F, Granzow H, Klupp BG: **The way out: what we know and do not know about herpesvirus nuclear egress.** *Cell Microbiol* 2013, **15**:170-178.
36. Speese SD, Ashley J, Jokhi V, Nunnari J, Barria R, Li Y, Ataman B, Koon A, Chang Y-T, Li Q *et al.*: **Nuclear envelope budding enables large ribonucleoprotein particle export during synaptic Wnt signaling.** *Cell* 2012, **149**:832-846.
- This paper provides the first experimental proof for the egress mechanism being an endogenous export pathway. Authors investigate ribonucleoprotein particles (RNPs) formation and transport from the nucleus in *Drosophila melanogaster*. Using microscopy they show RNPs localize to the perinuclear space and can leave the nucleus. The same local lamina remodeling machinery is used as during viral egress.
37. Rose A, Schlieker C: **Alternative nuclear transport for cellular protein quality control.** *Trends Cell Biol* 2012, **22**:509-514.
38. Elad N, Maimon T, Frenkiel-Krispin D, Lim RY, Medalia O: **Structural analysis of the nuclear pore complex by integrated approaches.** *Curr Opin Struct Biol* 2009, **19**:226-232.
39. Frenkiel-Krispin D, Maco B, Aebi U, Medalia O: **Structural analysis of a metazoan nuclear pore complex reveals a fused concentric ring architecture.** *J Mol Biol* 2010, **395**: 578-586.
40. Maimon T, Medalia O: **Perspective on the metazoan nuclear pore complex.** *Nucleus* 2010, **1**:383-386.
41. Beck M, Lucić V, Förster F, Baumeister W, Medalia O: **Snapshots of nuclear pore complexes in action captured by cryo-electron tomography.** *Nature* 2007, **449**:611-615.
42. Alber F, Dokudovskaya S, Veenhoff LM, Zhang W, Kipper J, Devos D, Suprpto A, Karni-Schmidt O, Williams R, Chait BT *et al.*: **The molecular architecture of the nuclear pore complex.** *Nature* 2007, **450**:695-701.
43. Anderson DJ, Vargas JD, Hsiao JP, Hetzer MW: **Recruitment of functionally distinct membrane proteins to chromatin mediates nuclear envelope formation in vivo.** *J Cell Biol* 2009, **186**:183-191.
44. Yewdell WT, Colombi P, Makhnevych T, Lusk CP: **Luminal interactions in nuclear pore complex assembly and stability.** *Mol Biol Cell* 2011, **22**:1375-1388.
45. Yavuz S, Santarella-Mellwig R, Koch B, Jaedicke A, Mattaj IW, Antonin W: **NLS-mediated NPC functions of the nucleoporin Pom121.** *FEBS Lett* 2010, **584**:3292-3298.
46. Doucet CM, Talamas JA, Hetzer MW: **Cell cycle-dependent differences in nuclear pore complex assembly in metazoa.** *Cell* 2010, **141**:1030-1041.
47. Talamas JA, Hetzer MW: **POM121 and Sun1 play a role in early steps of interphase NPC assembly.** *J Cell Biol* 2011, **194**:27-37.
48. Mitchell JM, Mansfeld J, Capitanio J, Kutay U, Wozniak RW: **Pom121 links two essential subcomplexes of the nuclear pore complex core to the membrane.** *J Cell Biol* 2010, **191**: 505-521.
49. Shaulov L, Gruber R, Cohen I, Harel A: **A dominant-negative form of POM121 binds chromatin and disrupts the two separate modes of nuclear pore assembly.** *J Cell Sci* 2011, **124**:3822-3834.
50. Heessen S, Fornerod M: **The inner nuclear envelope as a transcription factor resting place.** *EMBO Rep* 2007, **8**:914-919.
51. Towbin BD, Meister P, Gasser SM: **The nuclear envelope — a scaffold for silencing?** *Curr Opin Genet Dev* 2009, **19**:180-186.
52. Mekhail K, Moazed D: **The nuclear envelope in genome organization, expression and stability.** *Nat Rev Mol Cell Biol* 2010, **11**:317-328.
53. Solovei I, Wang AS, Thanisch K, Schmidt CS, Krebs S, Zwerger M, Cohen TV, Devys D, Foisner R, Peichl L *et al.*: **LBR and lamin A/C sequentially tether peripheral heterochromatin and inversely regulate differentiation.** *Cell* 2013, **152**:584-598.
- The authors study the rod photoreceptor cells from nocturnal mammals, which have inverted chromatin architecture (with heterochromatin in the center of the nucleus), and discover the sequential expression of LBR and lamin A during development of many cell types and its effect on chromatin positioning and transcription.
54. Zuleger N, Boyle S, Kelly DA, las Heras de JI, Lazou V, Korfali N, Batrakou DG, Randles KN, Morris GE, Harrison DJ *et al.*: **Specific nuclear envelope transmembrane proteins can promote the location of chromosomes to and from the nuclear periphery.** *Genome Biol* 2013, **14**:R14.
- Certain chromosomes are at the nuclear periphery in some tissues, and in the nuclear interior in others, which has obvious effects on expression of encoded proteins. Authors postulate that this observation might be caused by tissue specific expression of novel nuclear envelope proteins that they identified before.
55. Park E, Rapoport TA: **Mechanisms of Sec61/SecY-mediated protein translocation across membranes.** *Annu Rev Biophys* 2012, **41**:21-40.
56. Denic V: **A portrait of the GET pathway as a surprisingly complicated young man.** *Trends Biochem Sci* 2012, **37**:411-417.
- While the cotranslational pathway of membrane proteins insertion into the ER was discovered more than 30 years ago, the first molecular players in the posttranslational insertion pathway for tail-anchored proteins were only discovered in Since then great progress in understanding the GET (Guided Entry of Tail Anchored proteins) was made, reviewed here.
57. Rout MP, Aitchison JD, Suprpto A, Hjertaas K, Zhao Y, Chait BT: **The yeast nuclear pore complex: composition, architecture, and transport mechanism.** *J Cell Biol* 2000, **148**:635-651.
58. Cronshaw JM, Krutchinsky AN, Zhang W, Chait BT, Matunis MJ: **Proteomic analysis of the mammalian nuclear pore complex.** *J Cell Biol* 2002, **158**:915-927.
59. Aitchison JD, Rout MP: **The yeast nuclear pore complex and transport through it.** *Genetics* 2012, **190**:855-883.

60. Friederichs JM, Gardner JM, Smoyer CJ, Whetstone CR, Gogol M, Slaughter BD, Jaspersen SL: **Genetic analysis of Mps3 SUN domain mutants in *Saccharomyces cerevisiae* reveals an interaction with the SUN-like protein Slp1.** *G3 (Bethesda)* 2012, **2**:1703-1718.
61. Hasan S, Güttinger S, Mühlhäusser P, Anderegg F, Bürgler S, Kutay U: **Nuclear envelope localization of human UNC84A does not require nuclear lamins.** *FEBS Lett* 2006, **580**:1263-1268.
62. Hodzic DM: **Sun2 is a novel mammalian inner nuclear membrane protein.** *J Biol Chem* 2004, **279**:25805-25812.
63. Zuleger N, Kelly DA, Richardson AC, Kerr ARW, Goldberg MW, Goryachev AB, Schirmer EC: **System analysis shows distinct mechanisms and common principles of nuclear envelope protein dynamics.** *J Cell Biol* 2011, **193**:109-123.
64. Furukawa K, Fritze CE, Gerace L: **The major nuclear envelope targeting domain of LAP2 coincides with its lamin binding region but is distinct from its chromatin interaction domain.** *J Biol Chem* 1998, **273**:4213-4219.
65. Burke B, Stewart CL: **The laminopathies: the functional architecture of the nucleus and its contribution to disease.** *Annu Rev Genom Hum Genet* 2006, **7**:369-405.
66. Furukawa K, Panté N, Aebi U, Gerace L: **Cloning of a cDNA for lamina-associated polypeptide 2 (LAP2) and identification of regions that specify targeting to the nuclear envelope.** *EMBO J* 1995, **14**:1626-1636.
67. Brachner A, Reipert S, Foisner R, Gotzmann J: **LEM2 is a novel MAN1-related inner nuclear membrane protein associated with A-type lamins.** *J Cell Sci* 2005, **118**:5797-5810.
68. Wu W, Lin F, Worman HJ: **Intracellular trafficking of MAN1, an integral protein of the nuclear envelope inner membrane.** *J Cell Sci* 2002, **115**:1361-1371.
69. Smith S, Blobel G: **The first membrane spanning region of the lamin B receptor is sufficient for sorting to the inner nuclear membrane.** *J Cell Biol* 1993, **120**:631-637.
70. Soullam B, Worman HJ: **The amino-terminal domain of the lamin B receptor is a nuclear envelope targeting signal.** *J Cell Biol* 1993, **120**:1093-1100.
71. Soullam B, Worman HJ: **Signals and structural features involved in integral membrane protein targeting to the inner nuclear membrane.** *J Cell Biol* 1995, **130**:15-27.
72. Ma Y, Cai S, Lv Q, Jiang Q, Zhang Q, Sodmergen, Zhai Z, Zhang C: **Lamin B receptor plays a role in stimulating nuclear envelope production and targeting membrane vesicles to chromatin during nuclear envelope assembly through direct interaction with importin beta.** *J Cell Sci* 2007, **120**:520-530.
73. Rolls MM, Stein PA, Taylor SS, Ha E, McKeon F, Rapoport TA: **A visual screen of a GFP-fusion library identifies a new type of nuclear envelope membrane protein.** *J Cell Biol* 1999, **146**:29-44.
74. Hofemeister H, O'Hare P: **Analysis of the localization and topology of nurim, a polytopic protein tightly associated with the inner nuclear membrane.** *J Biol Chem* 2004, **280**:2512-2521.