

University of Groningen

## Hands-free Voice Restoration

Kalkeren, Theodoor Aries van

**IMPORTANT NOTE: You are advised to consult the publisher's version (publisher's PDF) if you wish to cite from it. Please check the document version below.**

*Document Version*

Publisher's PDF, also known as Version of record

*Publication date:*

2014

[Link to publication in University of Groningen/UMCG research database](#)

*Citation for published version (APA):*

Kalkeren, T. A. V. (2014). *Hands-free Voice Restoration: Clinical aspects of the development of a hands-free speech valve and its fixation for laryngectomy patients*. s.n.

### Copyright

Other than for strictly personal use, it is not permitted to download or to forward/distribute the text or part of it without the consent of the author(s) and/or copyright holder(s), unless the work is under an open content license (like Creative Commons).

The publication may also be distributed here under the terms of Article 25fa of the Dutch Copyright Act, indicated by the "Taverne" license. More information can be found on the University of Groningen website: <https://www.rug.nl/library/open-access/self-archiving-pure/taverne-amendment>.

### Take-down policy

If you believe that this document breaches copyright please contact us providing details, and we will remove access to the work immediately and investigate your claim.

*Downloaded from the University of Groningen/UMCG research database (Pure): <http://www.rug.nl/research/portal>. For technical reasons the number of authors shown on this cover page is limited to 10 maximum.*

# **Hands-free Voice Restoration**

**Clinical aspects of the development of a hands-free speech valve and its fixation for laryngectomy patients**

T.A. van Kalkeren

## Colophon

Design/Layout/Cover: Ferdinand van Nispen, Citroenvlinder-dtp.nl, Bilthoven,  
The Netherlands

Print: GVO drukkers & vormgevers B.V., Ede, The Netherlands

ISBN: 978-90-6464-739-0

The *in-vivo* studies have been made possible as a result of grants by the “Stichting Tonny en Luit Stol Baflo” and the “Stichting Familie Stol-Hoeksema”; two foundations in favor of supporting healthcare with its focus on cancer control and humanitarian aid.

The publication of this thesis was financially supported by: Atos Medical, ChipSoft, Chiesi Farmaceutici, Daleco Pharma, Dos Medical/KNO-winkel.nl, Eelco Huizinga Stichting, GlaxoSmithKline, De Haan Hoorapparaten Leeuwarden, Olympus Nederland B.V., Patiëntenvereniging NSvG/Michiel Keijzer Fonds, Servona.

Authors E.B. van der Houwen, G.J. Verkerke, and B.F.A.M van der Laan are inventors/ applicants of the patent “Tracheostoma valve,” WO 2010/114372.1

© Theodoor A. van Kalker, 2014

Hands-free Voice Restoration: Clinical aspects of the development of a hands-free speech valve and its fixation for laryngectomy patients.

Thesis Rijksuniversiteit Groningen.

All rights reserved. No part of this publication may be reproduced in any form of by any means, electronically, mechanically, by print or otherwise without written permission of the copyright owner.



rijksuniversiteit  
groningen

## Hands-free Voice Restoration

Clinical aspects of the development of a hands-free speech valve  
and its fixation for laryngectomy patients

### Proefschrift

ter verkrijging van de graad van doctor aan de  
Rijksuniversiteit Groningen  
op gezag van de  
rector magnificus, prof. dr. E. Sterken  
en volgens besluit van het College voor Promoties.

De openbare verdediging zal plaatsvinden op  
woensdag 22 januari 2014 om 14:30 uur

door

**Theodoor Aries van Kalkeren**

geboren op 19 juli 1978  
te Zoelen

**Promotores:**

Prof. dr. B.F.A.M. van der Laan

Prof. dr. ir. G.J. Verkerke

**Beoordelingscommissie:**

Prof. dr. P.U. Dijkstra

Prof. dr. F.J.M. Hilgers

Prof. dr. G. Rakhorst

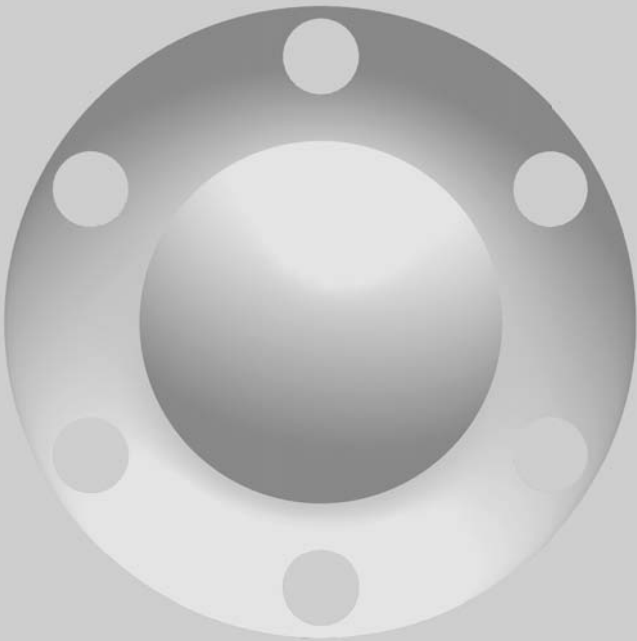
Aan mijn ouders

# Contents

<b>1</b>	<b>General introduction</b>	9
	<b>Stoma geometry</b>	23
<b>2</b>	<b>Stoma geometry and clinical implications</b> Worldwide, Multi Center Study of Peristomal Geometry and Morphology in Laryngectomees and its Clinical Effects. Head & Neck. 2011 Aug; Volume 33, Issue 8, Pages 1184-1190.	25
<b>3</b>	<b>Stoma geometry and patch use</b> Does the patch fit the stoma? A study on peristoma geometry and patch use in laryngectomized patients. Clinical Otolaryngology. 2011 Jun; Volume 36, Issue 3, Pages 209-302.	39
	<b>A new stoma patch</b>	53
<b>4</b>	<b><i>In vitro</i> evaluation of stoma patch adhesives</b> The best tracheostoma patch adhesives. In Vitro comparison of 5 adhesive systems. Submitted	55
<b>5</b>	<b><i>In vivo</i> evaluation of the iPatch</b> In Vivo Evaluation of the iPatch: A Novel Tracheostoma Patch. Submitted	67

<b>A new hands-free speech valve</b>		77
<b>6</b>	<b><i>In vitro</i> evaluation of the iValve v1</b>	79
	In Vitro Evaluation of the iValve: A Novel Hands-Free Speech Valve. Annals of Otolaryngology, Rhinology & Laryngology. 2011 Dec; Volume 120, Issue 12, Pages 814-819.	
<b>7</b>	<b><i>In vivo</i> evaluation of the iValve v1</b>	93
	In Vivo Test of a New Hands-Free Tracheostoma Inhalation Valve. Clinical Otolaryngology, 2013 Oct; Volume 38, Issue 5, Pages 420-424.	
<b>8</b>	<b>General discussion and Conclusions</b>	105
<b>9</b>	<b>Summary &amp; Samenvatting</b>	115
	Acknowledgements & Dankwoord	129
	Curriculum Vitae	134





# 1

## General Introduction

## General Introduction

In The Netherlands an estimated 40% of male and 30% of female are diagnosed with a malignancy during the course of their life. At this time of writing about 67.000 new cases of cancer were diagnosed.

Head and neck cancer is ranked as the fourth most frequent cancer among males, with some 2500 to 2800 new cases a year. About a third of the patients die as a consequence of their disease <sup>1,2</sup>.

### Laryngeal cancer

At this time of writing, every year in The Netherlands about 700 people are diagnosed with laryngeal cancer <sup>2</sup>. Laryngeal cancer is mainly diagnosed in male. However, male present a declining incidence, this decline does not show in female. The male to female ratio declined from 7:1 in 1989–1995 to 5:1 in 2003–2010 <sup>3</sup>. It is probably an effect of a rising trend of more smoking and drinking by women in the last years, which are well known risks for laryngeal cancer. However, in the Netherlands a recent Tobacco Act sets out measures to curb tobacco use and protect non-smokers from passive smoking. It gives everyone the right to work in a smoke-free environment. Smoking is now banned in most pubs, clubs and restaurants, although small bars run by self-employed people with no employees were exempt from the ban for some years. This act will be will be changed again in juli 2014 when the smoking ban will be reinstalled across the entire hospitality industry. It will only be permitted in separate sealed-off smoking areas without service. It is likely that these measures are going to change this trend.

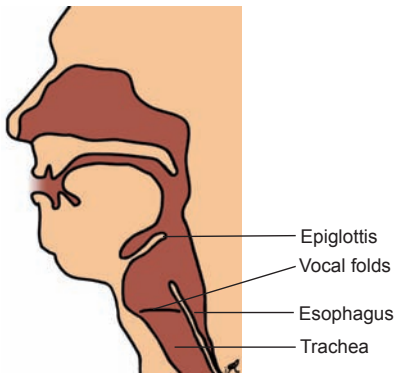
### Laryngectomy

A total laryngectomy is the standard technique for treatment of high stage carcinoma of the larynx, either in the glottis, subglottis or supraglottis. Nowadays, laryngectomy is mostly used as salvage therapy for tumor recurrence after (laser-) surgery, radiotherapy, or chemo-radiation treatment <sup>4</sup>. The incidence of new patients with laryngeal cancer is about 700 per year, accounting for less than 1% of all tumors <sup>3</sup>.

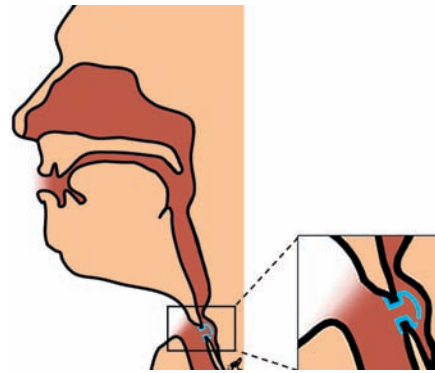
A total laryngectomy consists of the surgical removal of the larynx including vocal folds and epiglottis (Figure 1). The trachea is cut from the larynx and is

guided outside to the anterior neck, where it is sutured to the skin forming a tracheostoma. Breathing is now performed via the tracheostoma. The airway tract is now completely separated from the alimentary tract (Figure 2).

A laryngectomy has profound consequences for the patient. Patients often have difficulties in speaking, swallowing and affected senses of smell (and taste) reflecting the inability to sniff often occur. The inhaling air is not filtered, not moisturized and is not heated. This may have a profound adverse effect on the patient's physical, functional, and emotional health, and may result in a decreased quality of life (QOL) <sup>5</sup>.

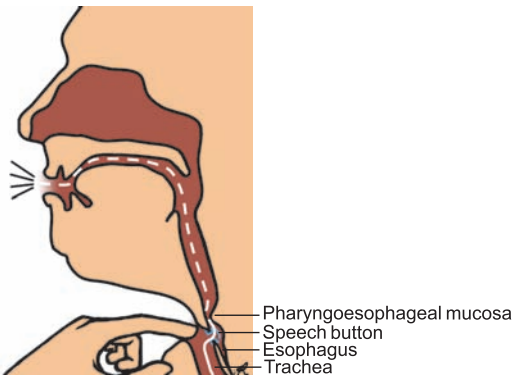


**Figure 1.** The normal situation in which the larynx (in conjunction with the vocals folds and epiglottis) is still in place.



**Figure 2.** The situation after removal of the larynx, including the vocal folds and epiglottis. The trachea is now connected to the lower neck. It completely separates the air and food pathway.

A voice prosthesis is situated as a one way shunt valve (blue) in an artificially created fistula between esophagus and trachea.



**Figure 3.** Digital closure of the tracheostoma during exhaling causes airflow (white line) from the trachea through the voice button into the oesophagus. The pharyngoesophageal mucosa starts to vibrate and produces a tone that enables the patient to speak.

## Voice Rehabilitation

### *History*

Billroth carried out the first successful laryngectomy on New Years Eve 1873 <sup>6</sup>. Since then, there have been many efforts to give a new voice to laryngectomies. In 1874 a staff member of Billroth, Carl Gussenbauer, described this operation an “artificial larynx”, which was designed by the technician of the department and was tested in dogs prior to the surgery. This first ‘voice prosthesis’ shunted air from the trachea into the pharynx along a sound-producing reed similar to the reed in a mouth harp <sup>7</sup>. About half a century later in 1922, Seeman is stated to be the first to describe the ability of the pharynx, esophagus and stomach to act as air reservoirs, the modus operandi of esophageal speech <sup>8-13</sup>. In this way of voicing, air is injected into the upper esophagus and then released in a controlled manner to create sound used to produce speech. Because of the high level of difficulty in learning esophageal speech, a minority of the patients are able to master this skill. In 1932 the first report of a tracheoesophageal puncture was made by Guttman <sup>14</sup>. A laryngectomized patient was said to use a hot ice pick to create a tracheoesophageal puncture as part of a suicidal attempt. This tracheoesophageal puncture, however, allowed him to speak by forcing air through the puncture to the esophagus when closing off the tracheostoma by using his hand; a successful self-rehabilitation, with the necessary aspiration prevention achieved with a gooth feather.

It is stated that in 1942, Wright, invented an electro-mechanical method to transmit sound through the soft tissue of the neck. He did so by attaching small loudspeakers to the throat. By this means he invented the first electronic larynx known as Sonovox.

Blom and Singer initiated the tracheoesophageal puncture and silicone rubber shunt prosthesis in 1979 <sup>15</sup>. During the next 3 decades, several variations of the silicone rubber shunt prosthesis have been made. However, the general principle is unchanged at present.

### *Present*

Whereas many methods of rehabilitation are available the rehabilitation using a tracheoesophageal shunt prosthesis is the Gold standard in speech rehabilitation <sup>1611-13, 17, 18</sup>. Voice restoration by tracheoesophageal speech is achieved at a higher success rate as compared to esophageal speech <sup>19</sup>.



By this method a shunt between the esophagus and the trachea is made during the laryngectomy. In this shunt a voice prosthesis made of silicone rubber is placed (Figure 2). This voice prosthesis has a valve that can open only in the esophageal direction and thus prevents food or fluids from entering the trachea. When the patient wants to phonate he or she will inhale air into the lungs through the tracheostoma, then the tracheostoma has to be closed off by a finger or thumb so that no air can escape through the tracheostoma while exhaling (Figure 3). The exhaled air will be pushed through the valve of the voice prosthesis into the esophagus and out of the mouth. This airflow will cause the pharyngoesophageal mucosa to start vibrating and producing sound, allowing voice production and speech.

With the introduction of low-pressure shunt valves<sup>20-22</sup>, and additional myotomy of the cricopharyngeal and lower pharyngeal constrictor muscles these results have even further improved<sup>23-25</sup>.

### **Tracheostoma Valves**

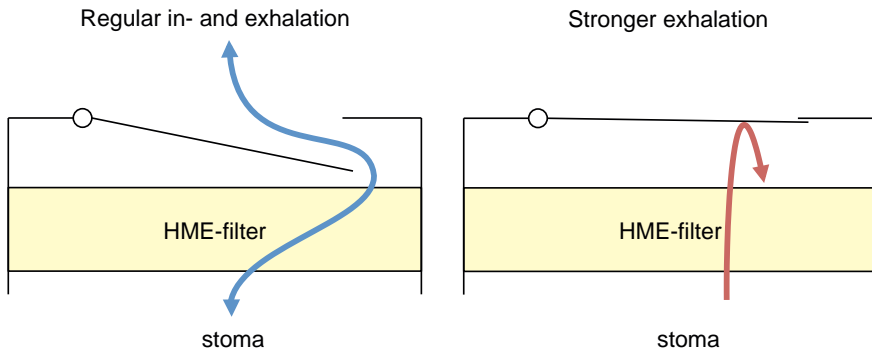
Tracheoesophageal speech requires the patient to use a finger to occlude the tracheostoma. As a result, the patient needs at least one hand to initiate speech, which restricts movement, points to the disability and is deemed unhygienic (Figure 3).

To tackle this problem the first hands-free tracheostoma valve was developed by Blom et al. in 1982, which reduced the need for digital closure of the tracheostoma<sup>26</sup>. To initiate speech, this type of tracheostoma valve relies on a slight increase of exhalation pressure by the patient, needed to close the hands-free tracheostoma valve. This type of valve is therefore called an exhalation valve (Figure 4).

These exhalation valves are very popular and are well known to improve the quality of life<sup>27, 28</sup>. The most used valve in The Netherlands is the Atos Provox Freehands (Atos Medical AG, Hörby, Sweden) adjustable tracheostoma valve.

However these type of valves also have their drawbacks. First of all, the valve opens again as the pressure in the trachea becomes negative, at the beginning of an inhalation. Secondly, exhaled air is spent to close the valve, wasting valuable air to speak. Magnets in the tip of the membrane and the housing of the FreeHands exhalation valve are partly solving these two issues, because they enable the membrane to stay closed with the slightest of exhalation pressure, and only release

and thus allow the membrane to open at the onset of inhalation<sup>28</sup>. Thirdly, a sudden positive intra-tracheal pressure, during exhalation, accompanies closing of the valve. This could exert a considerable force between the valve and the connection of the valve to the patient. A new tracheostoma valve design was therefore recommended by Geertsema et al.<sup>29-32</sup>. This valve closes by means of inhalation thus saving air for phonation during exhalation. Furthermore, it has the possibility to pause between words, enabling continuous speech and supporting natural pauses. This valve is developed further into a prototype that is available for testing<sup>33</sup>.



**Figure 4.** Schematic view of the currently available exhalation tracheostoma valves. left; the valve is open during inhalation, right: A short burst of air closes the valve.

### Tracheostoma Aid fixation

A well-known difficulty in tracheostoma valve use is its attachment to the skin around the stoma. The aim is to produce a reliable air-tight seal between the valve and the trachea. As fast exhalation of air is needed to close the current tracheostoma valves, its use is considered to exert extra stress on the interface between the stoma and the valve.

A number of concepts have been developed to improve the fixation of a tracheostoma valve to the tracheostoma. Intratracheal fixation with a button can sometimes overcome the peristomal attachment problems<sup>34</sup>. However a considerable number of patients are not able to achieve hands-free speech with a speech valve this way<sup>35</sup>.

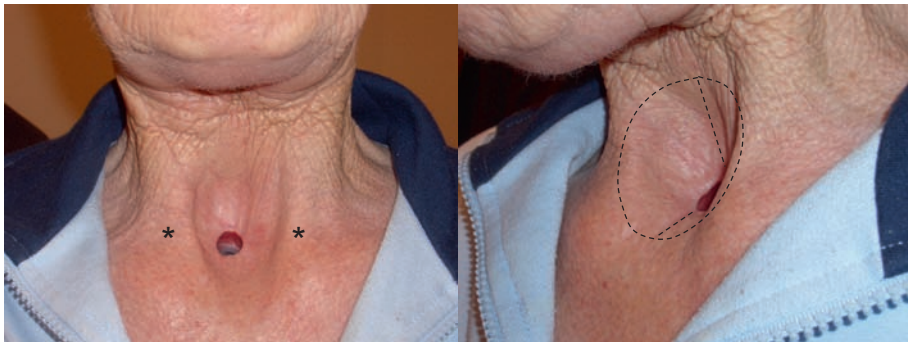
Furthermore, adhesive patches (Figure 5) can be applied to attach the valve to the soft tissue surrounding the stoma (peristomal area). The time that this sealed fixation method is airtight is very unreliable and shows a large variation over

patients. This issue (in part) has been solved by the build-in spring function in modern adhesive patches: the adhesive itself is attached away from the free inner-edge of the housing, which allows the latter to move outward without extra stress on the free edge of the adhesive itself<sup>36</sup>.

Poor fit, poor gluing capability and skin irritation of the adhesive patches are the main reasons for not wearing adhesive stoma patches and thus tracheostoma valves cannot be used<sup>37,38</sup>.



**Figure 5.** A collection of commercially available tracheostoma patches. All but one (bottom left) are flat, which is not in accordance to the peristomal skin geometry (Figure 6).



**Figure 6.** The tracheostoma geometry, 1 year after operation: the trachea ends in a recession between the two sternocleidomastoid muscles (left, marked with an \*), creating a funnel shape (right, dotted line).

Up until recently, most commercial patches currently available were shaped as a flat unit. As can be seen in Figure 6, this is not in accordance with the typical peristomal shape. The trachea is situated in a depression between the two sternocleidomastoid muscles. This anatomy forms a cone-shaped geometry. In 2012, the Provox StabiliBase was introduced. The patch consists of a new adhesive



baseplate, which is convex in shape, has a firm base, and contains stabilizing bars. The Provox StabiliBase was designed with improved stability to counteract the phonatory pressure during voicing<sup>36</sup>.

To improve the tracheostoma valve interface, first detailed knowledge on peristomal geometry and its clinical influences is needed. This will serve as the basis to design and build a new tracheostoma interface.

Furthermore, the shape of the tracheostoma changes as neck rotates and flexes during head movements. Current commercial tracheostoma patches use materials that cannot completely follow the flexibility of the peristomal skin and as a result cause shear forces. This could contribute to the short lifetime and skin irritation of the current tracheostoma patches. Therefore we intended to develop a new patch, made out of thin, soft and flexible silicone rubber, this design is in contrast to the Provox StabiliBase, which has a firm base and includes stabilizing bars.

## **Objective of the Thesis**

The general aim of the research presented in this thesis is to improve hands-free speech in laryngectomy patients.

### **Toward optimization of the interface between patient and speech valve**

To improve the attachment of speech valves and filters using stoma patches, optimization of the connection between the stoma patch and the skin should be achieved in several perspectives. First of all, the geometry of the stoma patch should resemble the normal shape of the skin surrounding the stoma. However, the actual shape of the tracheostoma is unknown. We therefore measured the stoma geometry worldwide and made a model for the general shape of the stoma. Secondly, the stoma patch should benefit from the most effective adhesive. However, the most efficient adhesive glue is not even known by the manufacturers of the glue itself. We measured the adhesive capability of five current available stoma patches and sought for an effective alternative adhesive to stick the patch to the skin around the stoma.



## **Toward realization of a new hands-free speech valve**

The current exhalation speech valves do not allow inhalation in the mid of a sentence, which hampers natural speech. Furthermore, exhaled air is spent to close the valve, wasting valuable air to speak. And the valves exert a considerable force between the valve and connection to the patient. To tackle these problems, we pursued to realize a new speech valve based on the principle of inhalation, in contrast to the present-day exhalation. This new valve and its characteristics were tested in vitro and optimized on laryngectomy patients.

## **Outline of the Thesis**

Pertaining to the aim to improve the performance of tracheostoma patches, our worldwide research on the geometry of the peristoma is presented in Chapter 2 and 3. It describes the most comprehensive study to date in which data is presented about the actual dimensions of the skin surrounding the tracheostoma. In this perspective we studied the peristomal area as it is changed by laryngectomy and the effects of several factors on the peristomal geometry. We investigated whether the number of removed trachea rings, incision of the sternocleidomastoid muscles, neck dissection, reconstruction, time after operation, and age had any effect on the (peri)stomal geometry of the patient (Chapter 2). Next, we address the need for laryngectomees to use adhesive patches on their stoma to connect filters and speech valves. We studied the geometry of (peri)stomas in relation to patch use. We address improvement of tracheostoma interfaces, specifically attending patients currently incapable to use stoma patches (Chapter 3).

It is not known which tracheostoma patch adhesive is best. Both for possible clinical and research purposes, an over-the-counter prosthesis adhesive was tested in vitro on artificial skins and compared to four other commercially available adhesive patches. In order to gather these data, a special test setup was build (Chapter 4).

The study to improve the attachment of tracheostoma patches for laryngectomy patients is presented in Chapter 5. Given the current available tracheostoma patch geometry is not conform the actual stoma shape, a new tracheostoma patch is

investigated. This new design is based upon new insights into the peristomal skin geometry (Chapter 2 and 3). Furthermore, it is made flexible out of extreme thin and flexible silicone material. It addresses the need to have a more natural fit to the peristomal anatomy of the laryngectomised patient facilitating maximum comfort.

In Chapter 6 we performed an in vitro study of a novel, disposable, automatic hands-free tracheostoma speech valve for laryngectomy patients based upon the principle of inhalation. The commercially available automatic speech valves close upon strong exhalation and open again when the pressure drops.

In the last chapter of this thesis (Chapter 7), a study is presented in which the prototype iValve was tested on patients. Furthermore, the performance of the iValve was reviewed to the current most widely used exhalation tracheostoma valve, the Atos-Provox® Free Hands HME.



## Reference List

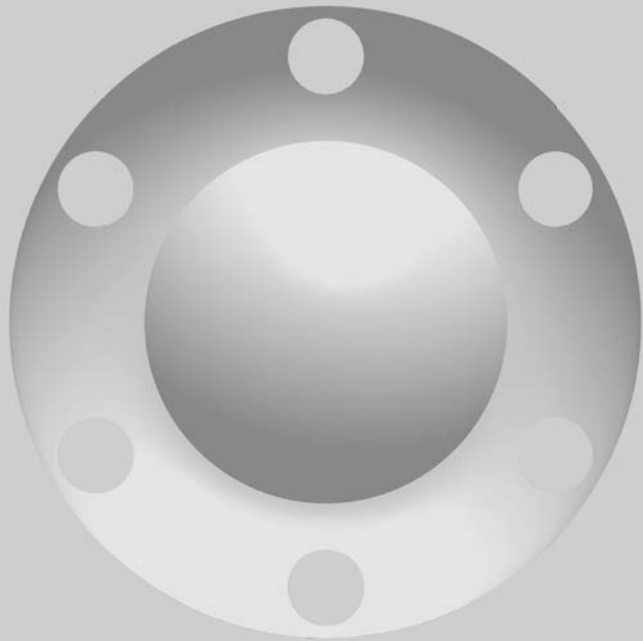
1. Cijfers en gegevens over strottenhoofdkanker. 2009.
2. KWF kankerbestrijding. Cijfers en gegevens over kanker in Nederland. 2009.
3. van Dijk BA, Karim-Kos HE, Coebergh JW, Marres HA, de Vries E. Progress against laryngeal cancer in The Netherlands between 1989 and 2010. *Int J Cancer* 2013.
4. Kaanders JH, Hordijk GJ. Carcinoma of the larynx: the Dutch national guideline for diagnostics, treatment, supportive care and rehabilitation. *Radiother Oncol* 2002;63:299-307.
5. Hilgers FJ, Aaronson NK, Ackerstaff AH, Schouwenburg PF, van Zandwijk N. The influence of a heat and moisture exchanger (HME) on the respiratory symptoms after total laryngectomy. *Clin Otolaryngol Allied Sci* 1991;16:152-156.
6. Lefebvre JL, Andry G, Chevalier D, et al. Laryngeal preservation with induction chemotherapy for hypopharyngeal squamous cell carcinoma: 10-year results of EORTC trial 24891. *Ann Oncol* 2012.
7. Gussenbauer C, Ueber C. Erste Durch Th. Billroth am menschen ausgefuhrte kehlkopf-exstirpation und die anwendung eines kunstlichen kehlkopfes. *Archiv Fur Klinische Chirurgie* 1874:334-56.
8. Burger H, Kaiser L. Spraak zonder strottenhoofd. *Nederlands Tijdschrift Voor Geneeskunde* 1925;69:906-917.
9. Damsté PH. Oesophageal speech after laryngectomy 1958.
10. Moolenaar - Bijl AJ. Consonant articulation and the intake of air in Oesophageal speech. *Folia Phoniatri* 1953;59:212-216.
11. Debruyne F, Delaere P, Wouters J, Uwents P. Acoustic analysis of tracheo-oesophageal versus oesophageal speech. *J Laryngol Otol* 1994;108:325-328.
12. Brown DH, Hilgers FJ, Irish JC, Balm AJ. Postlaryngectomy voice rehabilitation: state of the art at the millennium. *World J Surg* 2003;27:824-831.
13. Pauloski BR, Fisher HB, Kempster GB, Blom ED. Statistical differentiation of tracheoesophageal speech produced under four prosthetic/occlusion speaking conditions. *J Speech Hear Res* 1989;32:591-599.
14. Guttman MR. Rehabilitation of voice in laryngectomized patients. *Arch Otolaryngol* 1932:478-9.
15. Singer MI, Blom ED. An endoscopic technique for restoration of voice after laryngectomy. *Ann Otol Rhinol Laryngol* 1980;89:529-533.
16. Blom ED. Tracheoesophageal voice restoration: origin--evolution--state-of-the-art. *Folia Phoniatri Logop* 2000;52:14-23.
17. Robbins J, Fisher HB, Blom EC, Singer MI. A comparative acoustic study of normal, esophageal, and tracheoesophageal speech production. *J Speech Hear Disord* 1984;49:202-210.
18. Hilgers FJ, Balm AJ. Long-term results of vocal rehabilitation after total laryngectomy with the low-resistance, indwelling Provox voice prosthesis system. *Clin Otolaryngol Allied Sci* 1993;18:517-523.
19. Van Weissenbruch R, Albers FW. Vocal rehabilitation after total laryngectomy using the Provox voice prosthesis. *Clin Otolaryngol Allied Sci* 1993;18:359-364.
20. Hilgers FJ, Schouwenburg PF. A new low-resistance, self-retaining prosthesis (Provox) for voice rehabilitation after total laryngectomy. *Laryngoscope* 1990;100:1202-1207.
21. Smith BE. Aerodynamic characteristics of Blom-Singer low-pressure voice prostheses. *Arch Otolaryngol Head Neck Surg* 1986;112:50-52.
22. Zijlstra RJ, Mahieu HF, Lith-Bijl JT, Schutte HK. Aerodynamic properties of the low-resistance Groningen button. *Arch Otolaryngol Head Neck Surg* 1991;117:657-661.
23. Op de Coul BM, van den Hoogen FJ, van As CJ, et al. Evaluation of the effects of primary myotomy in total laryngectomy on the neoglottis with the use of quantitative videofluoroscopy. *Arch Otolaryngol Head Neck Surg* 2003;129:1000-1005.

24. Mahieu HF, Annyas AA, Schutte HK, van der Jagt EJ. Pharyngoesophageal myotomy for vocal rehabilitation of laryngectomees. *Laryngoscope* 1987;97:451-457.
25. Singer MI, Blom ED. Selective myotomy for voice restoration after total laryngectomy. *Arch Otolaryngol* 1981;107:670-673.
26. Blom E, Singer M, Hamaker R. Tracheostoma valve for postlaryngectomy voice rehabilitation. *Ann Otol Rhinol Laryngol* 1982;576-578.
27. Lorenz KJ, Groll K, Ackerstaff AH, Hilgers FJ, Maier H. Hands-free speech after surgical voice rehabilitation with a Provox((R)) voice prosthesis: experience with the Provox FreeHands HME tracheostoma valve((R)) system. *Eur Arch Otorhinolaryngol* 2007;264:151-157.
28. Op de Coul BM, Ackerstaff AH, van As-Brooks CJ, et al. Compliance, quality of life and quantitative voice quality aspects of hands-free speech. *Acta Otolaryngol* 2005;125:629-637.
29. Geertsema AA, Boonstra CW, Schutte HK, Verkerke GJ. Design and test of a new tracheostoma valve based on inhalation. *Arch Otolaryngol Head Neck Surg* 1999;125:622-626.
30. Geertsema AA, de Vries MP, Schutte HK, Lubbers J, Verkerke GJ. In vitro measurements of aerodynamic characteristics of an improved tracheostoma valve for laryngectomees. *Eur Arch Otorhinolaryngol* 1998;255:244-249.
31. Geertsema AA, Schutte HK, Verkerke GJ. In vivo measurements of an improved tracheostoma valve based on inhalation. *Ann Otol Rhinol Laryngol* 2002;111:142-148.
32. Geertsema AA, Boonstra CW, Schutte HK, Verkerke GJ. Design and test of a new tracheostoma valve based on inhalation. *Archives of Otolaryngology Head and Neck Surgery* 1999;125:622-626.
33. Van der Houwen EB. thesis; Development of a handsfree speech valve for laryngectomy patients. June 2012;1:99-119.
34. Hilgers FJ, Ackerstaff AH. Development and evaluation of a novel tracheostoma button and fixation system (Provox LaryButton and LaryClip adhesive) to facilitate hands-free tracheoesophageal speech. *Acta Otolaryngol* 2006;126:1218-1224.
35. Lewin JS, Lemon J, Bishop-Leone JK, Leyk S, Martin JW, Gillenwater AM. Experience with Barton button and peristomal breathing valve attachments for hands-free tracheoesophageal speech. *Head Neck* 2000;22:142-148.
36. Hilgers FJ, Dirven R, Wouters Y, Jacobi I, Marres HA, van den Brekel MW. A multicenter, prospective, clinical trial evaluating a novel adhesive baseplate (Provox StabiliBase) for peristomal attachment of postlaryngectomy pulmonary and voice rehabilitation devices. *Laryngoscope* 2012;122:2447-2453.
37. ten Hallers EJ, Marres HA, Rakhorst G, et al. Difficulties in the fixation of prostheses for voice rehabilitation after laryngectomy. *Acta Otolaryngol* 2005;125:804-813.
38. Hilgers FJ, Ackerstaff AH, van As CJ, Balm AJ, Van den Brekel MW, Tan IB. Development and clinical assessment of a heat and moisture exchanger with a multi-magnet automatic tracheostoma valve (Provox FreeHands HME) for vocal and pulmonary rehabilitation after total laryngectomy. *Acta Otolaryngol* 2003;123:91-99.

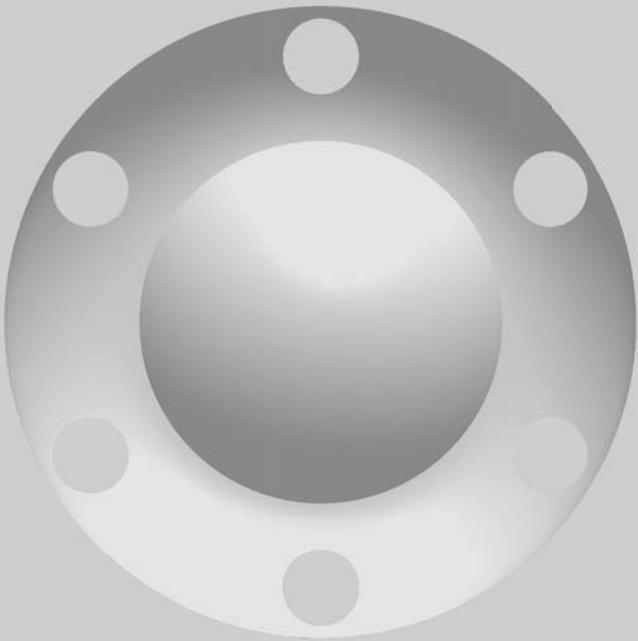




# Stoma geometry







# Worldwide, Multi Center Study of Peristomal Geometry and Morphology in Laryngectomees and its Clinical Effects.

T.A. van Kalkeren<sup>1</sup>, E.B. van der Houwen<sup>2</sup>, M.E. Duits<sup>1</sup>, F.J.M. Hilgers<sup>3</sup>, A. Hebe<sup>4</sup>, B.E. Mostafa<sup>5</sup>, G. Lawson<sup>6</sup>, Z. Martinez<sup>7</sup>, V. Woisard<sup>8</sup>, G. Marioni<sup>9</sup>, D. Ruske<sup>10</sup>, P. Schultz<sup>11</sup>,  
W.J. Post<sup>12</sup>, G.J. Verkerke<sup>2,13</sup>, B.F.A.M. van der Laan<sup>1</sup>

Head & Neck. 2011 Aug; Volume 33, Issue 8, Pages 1184-90.

<sup>1</sup>Dept of Otorhinolaryngology/Head&Neck Surgery and <sup>2</sup>Dept of Biomedical Engineering, University Medical Center Groningen, University of Groningen, Hanzeplein 1, PO BOX 30.000, 9700RB, Groningen, the Netherlands

<sup>3</sup>The Netherlands Cancer Institute, Institute of Phonetic Sciences, and Academic Medical Center, University of Amsterdam, Amsterdam, the Netherlands

<sup>4</sup>Dept of ORL, Instituto Português de Oncologia de Lisboa, Lisboa, Portugal

<sup>5</sup>Dept of ORL, HNS, Faculty of Medicine, Ain-Shams University, Cairo, Egypt

<sup>6</sup>Dept of ORL, HNS, University Hospital of Louvain at Mont-Godinne, Belgium

<sup>7</sup>Dept of ORL, Hospital Donostia, San Sebastián, Spain

<sup>8</sup>Dept of ORL, HNS, University Hospital of Rangueil Larrey, Toulouse, France

<sup>9</sup>Dept of Medical and Surgical Specialties, Section of Otolaryngology, University Hospital of Padova, Italy

<sup>10</sup>ORL Head and Neck Department, Dunedin Hospital, Otago, New Zealand

<sup>11</sup>Dept of ORL, HNS, University Hospital Strasbourg, France

<sup>12</sup>Dept of Epidemiology, University Medical Center Groningen, the Netherlands

<sup>13</sup>Faculty of Engineering Technology, University of Twente, the Netherlands

## Introduction

Total laryngectomy, as a primary treatment option, is performed in patients with advanced supraglottic T3/T4 cancers, T4a glottic cancers, T3/T4 subglottic cancers, or in patients with poor general conditions, or are unable to tolerate potential respiratory complications of partial surgery<sup>1</sup>. Furthermore, laryngectomy is often used as salvage therapy for tumor recurrence after surgery, radiotherapy, or chemoradiation treatment<sup>2</sup>. Total laryngectomy implies a permanent tracheostoma and laryngeal voice loss with permanent separation of the upper respiratory and digestive tracts. Patients who lose their larynx due to total laryngectomy can regain voice and speech in several ways.

The best quality of voice and speech is obtained using a shunt valve also known as tracheoesophageal voice and speech<sup>3-7</sup>. Furthermore, voice and speech restoration by tracheoesophageal speech is achieved at a higher success rate as compared to esophageal speech<sup>8</sup>. With the introduction of low-pressure shunt valves<sup>9-11</sup>, additional myotomy of the cricopharyngeal and lower pharyngeal constrictor muscles have improved these results even further<sup>12-14</sup>.

The shunt valve is a 1-way valve that operates as an artificial fistula connecting the trachea and esophagus. When the tracheostoma is occluded, the shunt valve allows air to be forced in the direction of the esophagus. This air induces vibration of the pharyngoesophageal mucosa and thus aids voice production and speech. However, this means of speech requires the patient to use his/her hand to occlude the tracheostoma. As a result, the patient needs at least 1 hand to initiate speech, which restricts mobility, points to the disability, and is deemed unhygienic. To tackle this problem, the first automatic tracheostoma valve was established in 1982, which reduced the need for digital closure of the tracheostoma<sup>15,16</sup>. This type of automatic tracheostoma valve, which is open throughout normal breathing, relies on a short burst of exhaled air when the patient wants to initiate speech. This short burst of air causes closure of the automatic tracheostoma valve. During inhalation, the automatic tracheostoma valve opens again. A recognized difficulty in automatic tracheostoma valve use is its attachment to the tracheostoma. Adhesive patches are applied to attach the automatic tracheostoma valve to the soft tissue surrounding the stoma (peristomal area). The aim is to produce an airtight seal. The length of time of this sealed fixation method is very inconsistent. Factors influencing the duration of this seal are back pressure, phlegm production,

and peristomal anatomy<sup>15</sup>. As a short burst of air is needed to close the current automatic tracheostoma valves, its use is considered to exert substantial stress on the interface between the stoma and the valve. Ten Hallers *et al*<sup>17</sup> and Hilgers *et al.*<sup>18</sup> show poor fit, poor gluing capability and skin irritation of the adhesive patches as the main reasons for not wearing ATVs and adhesive stoma patches<sup>19</sup>. The problem of fixation can be dealt with by applying a tailor-made ATV-interface<sup>20,21</sup>. This is done at considerable cost and, therefore, is not feasible for all patients.

To improve the automatic tracheostoma valve interface, knowledge on tracheostoma geometry and its clinical influences is imperative<sup>16</sup>. We studied the geometry of the peristomal area as it is changed by laryngectomy and we investigated the effects of several factors on the peristomal geometry. The factors we studied are the number of removed trachea rings, the incision of the sternal attachment of the sternocleidomastoid muscles (SCM), neck dissection, reconstruction, time after operation, admission of postoperative radiotherapy, and age of the patients.

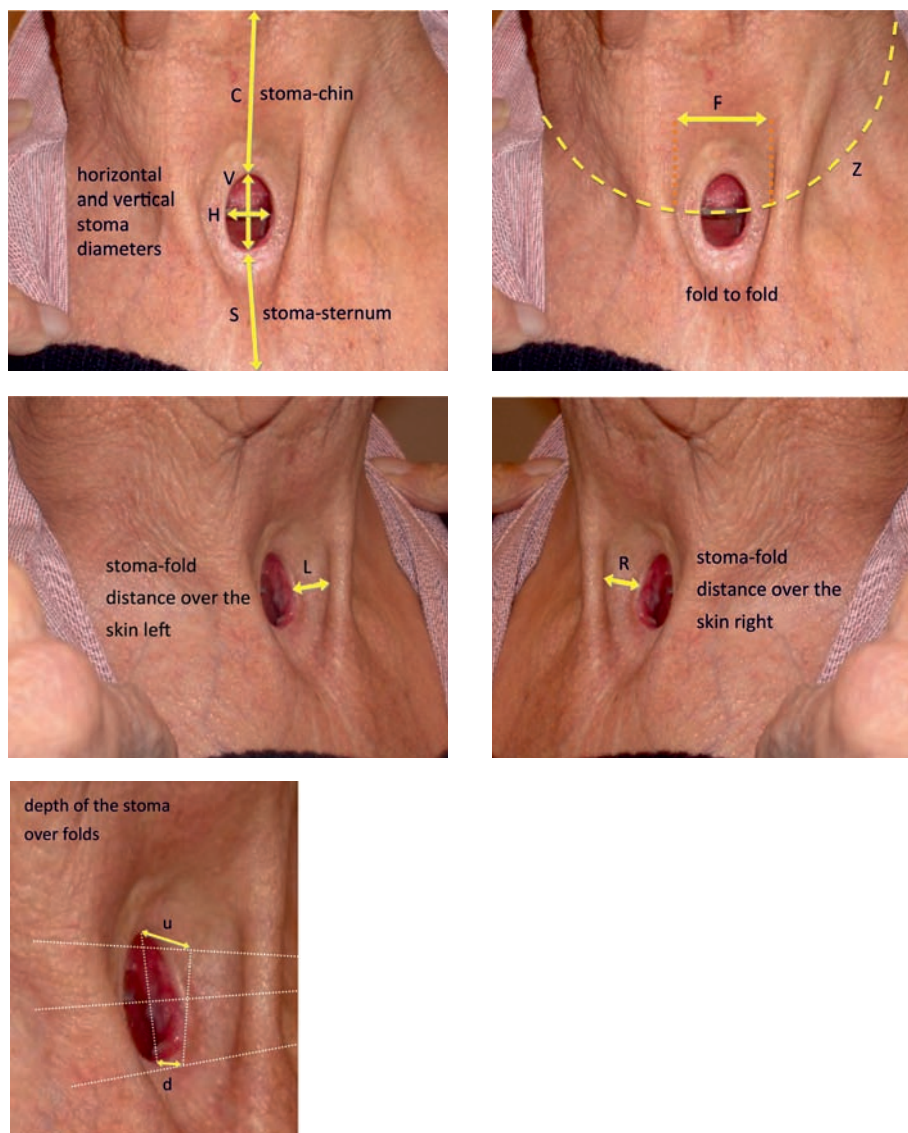
To our knowledge this is the first paper to present data of clinical implications on peristomal geometry in laryngectomized patients.

## Material and Methods

A total of 191 patients from 10 institutes across the world were included in this study. Inclusion criteria were patients who had undergone a total laryngectomy at least 1 year previously. Exclusion criteria were infection, ulceration or edema of the stoma, tumor recurrences, or poor wound healing in such a way that measuring the stoma was deemed unhygienic, painful, or difficult. All included patients were scheduled for routine check-ups (eg, shunt valve changes). This study was approved by the local medical ethical committee. The study protocol consisted of 4 main items: (1) imaging of the stoma, (2) 10 lengthwise measurements of the stoma and peristomal region, (3) classification of the stoma in predefined categories, and (4) a structured study-specific questionnaire.

Measurements included the following 10 items (Figure 1):





**Figure 1.** Visual overview of the 10 measurements on the peristomal area.

- (Z) circumference of the neck at stoma height,
- (H) horizontal diameter of the trachea opening in the skin (stoma),
- (V) vertical diameter of the trachea opening in the stoma,
- (F) distance between the SCM or skin folds,
- (C) upper border of the stoma until the hyoid or first skin fold,
- (S) lower border of the stoma until jugular notch of the sternum,
- (L) left border of stoma until SCM or skin fold,
- (R) right border of stoma until SCM or skin fold,
- (u) depth of the upper border of the stoma opening,
- (d) depth of the lower border of the stoma opening.

Item 4 consisted of a structured study-specific questionnaire comprising 23 items regarding stoma care and stoma fixated aids. From this list, we used the following items in this study: does the patient use a stoma aid on a regular basis, and if so, how long does the stoma aid stay in situ? Furthermore, 27 items regarding the patients' surgical history were filled in by the examiners. Items used in this study are listed in Table 1. Finally, the date of laryngectomy and age of the patient were noted.

**Table 1.** Overview of the data studied.

Factor	Variable
Number of removed trachea 'rings'	1,2,3,4 rings
SCM incision	Yes / No / Not applicable
Age	Age in months
Neck dissection	None / one sided / bilateral
Type of neck dissection	None / radical / modified / selective
Pharynx reconstruction	Yes / No
Radiotherapy	Yes/No

### **Statistical Analysis**

Effect of Number of Removed Trachea Cartilage "Rings" during Laryngectomy.

The total cohort consisted of 3 groups having 2 (n = 51), 3 (n = 36), and 4 (n = 10) tracheal rings removed, respectively. As only 2 patients had 1 trachea ring removed, these cases were excluded from further analysis. The 3 groups were compared using analysis of variance (ANOVA). In case of significant results, additional Bonferroni correction was used to adjust for multiple comparisons. Levene's test was used to check the equality of the variances of the different groups. In case of non-normality, data were log transformed. In case of non-normality of log transformation, data were evaluated using Kruskal–Wallis nonparametric test and Mann–Whitney U test. Data were analyzed using SPSS version 16.0.2. A 2-tailed p value of < .05 was considered to be statistically significant and 95% confidence interval (CI) was given.



***The Effect of Sternocleidomastoid Muscle Cleavage.***

Twenty-seven patients underwent cleavage of the sternal attachment of the SCM and 56 patients did not. Only the Dutch population was selected to compare. Given that all included Dutch surgeons involved in this study were trained at The Netherlands Cancer Institute – Antoni van Leeuwenhoek Hospital, the surgical technique was assumed to be similar. In addition, intraobserver bias was known to be more than adequate in the Dutch population within all measurements (unpublished data). No subdivision was made in whether a neck dissection was carried out. Independent samples t tests were performed to compare the peristomal dimensions in these 2 groups. Levene's test was used to check the equality of the variances of the different groups. When equality of the variances was not met, data were evaluated using a Mann–Whitney (Wilcoxon rank sum) nonparametric test.

***The Effect of Age and Time after Operation.***

To determine whether there was a correlation between the age of the patient and peristomal geometry, and whether there was a correlation between the time after operation and the peristomal geometry, Pearson correlation coefficients were used. In case of non-normality, Spearman rank correlation coefficients were used. Additionally, visual scatterplots and boxplots were made in order to visualize a possible correlation.

***The Effect on Pharyngeal Reconstruction.***

To investigate whether there was a difference in peristomal geometry when pharyngeal reconstruction was performed after total laryngectomy or not, the groups of patients who underwent a reconstruction ( $n = 21$ ) and the group of patients who did not ( $n = 96$ ) were compared with the independent samples t test. Levene's test was used to check the equality of the variances of the different groups. If equality of the variances was not met, data were evaluated using the Mann–Whitney nonparametric test.

***The Effect of Neck Dissection.***

To determine if there was a difference in peristomal anatomy in the group of patients who underwent a neck dissection, 3 groups were distinguished: patients who did not have a neck dissection ( $n = 36$ ), patients who had a 1-sided neck dissection (left,  $n = 9$ , in addition to right,  $n = 8$ ), and patients who had a bilateral neck dissection

(n = 67). These groups were compared using 1-way ANOVA. Furthermore, ANOVA was also used to compare the change in peristomal geometry as a result of the type of neck dissection; radical (n = 16), modified (n = 13), selective (n = 24), and absence of lymph node dissection (n = 24).

In case of significant results, additional Bonferroni correction was used to adjust for multiple comparisons.

Levene's test was used to check the equality of the variances of the different groups. If equality of the variances was not met, data were evaluated using a Kruskal–Wallis nonparametric test.

### ***The Effect of Radiotherapy.***

To investigate whether there was a difference in peristomal geometry when radiotherapy was performed after total laryngectomy or not, the group of patients who underwent radiotherapy (n = 70) and the group of patients who did not (n = 57) were compared using the independent samples t test. Levene's test was used to check the equality of the variances of the different groups. If equality of the variances was not met, data were evaluated using Mann–Whitney nonparametric test.

## **Results**

### ***General.***

One hundred ninety-one patients were included in this study, of which 10.4% were women. The average age was 65.5 years (range, 35–92 years). In total, 49.6% used an adhesive stoma patch on a regular (daily) basis. In the group of regular daily adhesive stoma patch users, the mean duration in situ was 25.6 hours (range, 0–7 days). The overall anatomy of the trachea opening and peristomal soft tissue is described in Table 2, as stated by van der Houwen *et al* (Chapter 3).





**Table 2.** Peristomal geometry, all measurements presented are in mm.

	Valid N	Mean	SD	95% CI
Circumference of the neck <i>Z</i>	166	367	33	310 - 420
Horizontal stoma diameter <i>H</i>	186	13	4	8 - 20
Vertical stoma diameter <i>V</i>	188	17	5	10 - 25
Distance Fold to Fold <i>F</i>	187	38	16	14 - 70
Distance Stoma to Chin <i>C</i>	186	35	15	10 - 114
Distance Stoma to Sternum <i>S</i>	188	24	9	10 - 40
Distance stoma to patients' right fold <i>R</i>	184	20	13	7 - 45
Distance stoma to patients' left fold <i>L</i>	185	19	9	8 - 40
Stoma depth hor. from upper side of stoma <i>u</i>	175	13	9	0 - 32
Stoma depth hor. from lower side of stoma <i>d</i>	175	12	8	0 - 27

### ***The Effect of Number of Removed Trachea Cartilage 'Rings' during Laryngectomy.***

With respect to the geometry *H*, the overall significance was 0.004. Paired comparisons using Bonferroni corrected result demonstrated a significant difference between the group with 2 removed trachea rings and 3 trachea rings. The horizontal stoma diameter (*H*) was an average 1.87 mm smaller ( $p = .01$ ; 95% CI, 0.40–3.33 mm) in the group with 3 removed trachea rings. Next, paired comparisons using Bonferroni corrected result demonstrated a significant difference between the group with 2 removed trachea rings and 4 trachea rings. The horizontal stoma diameter (*H*) was 3.33 mm in average smaller ( $p = .15$ ; 95% CI, 0.51–6.16 mm) and the vertical stoma diameter (*V*) 4.16 mm smaller ( $p = .03$ ; 95% CI, 0.25–8.08 mm) in the group with 4 removed trachea rings.

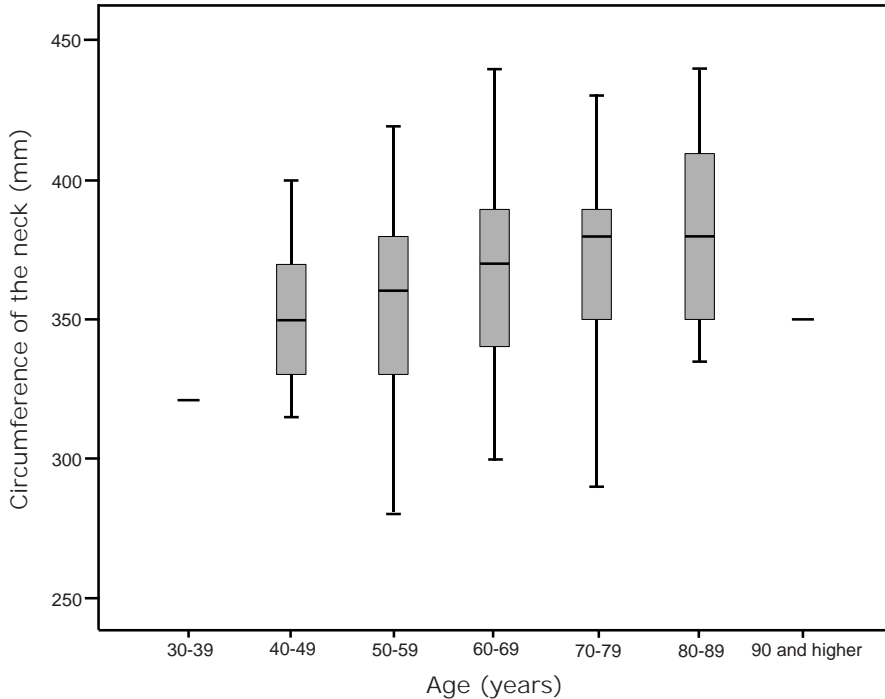
### ***The Effect of Sternocleidomastoid Muscle Cleavage.***

Using the *t* test did not show significant differences between the SCM-cleaved ( $n = 27$ ) and noncleaved group ( $n = 56$ ). Mann–Whitney test demonstrated a statistically significant difference in the distance from the stoma to the left fold (*L*) measurements ( $p = .02$ ) and in the distance from the upper border of the stoma to the chin (*Z*) measurements ( $p = .00$ ). No statistically significant difference was found between the cleaved and noncleaved patients' group in the measurements *H*, *V*, *F*, *C*, *S*, *R*, *u*, and *d*.

### ***The Effect of Age after Operation.***

A positive correlation was found between the age of the patient and the circumference of the neck (*Z*; ie, there is an increase in this circumference with increasing age, as is shown in Figure 2). Pearson correlation coefficient was 0.19

( $p = .02$ ). Furthermore, age demonstrated a positive Pearson correlation between the depth of the upper border (u) of the stoma ( $CC = 0.20$ ;  $p = .01$ ) and the depth of the lower border (d) of the stoma ( $CC = 0.17$ ;  $p = .04$ ). No additional significant correlations were found.



**Figure 2.** Boxplot demonstrating the relation between the age of the patient in years and the circumference of the neck. An increase in neck circumference is shown when the patient's age is higher.

#### ***The Effect of Time after Operation.***

A positive Pearson correlation between the time after operation and the distance from the upper border of the stoma to the chin (C) was demonstrated ( $CC = 0.182$ ;  $p = .04$ ). Furthermore, a negative Spearman's rho was shown between the time after operation and vertical diameter (V) of the stoma ( $CC = 0.18$ ;  $p = .04$ ). No significant correlation between the horizontal diameter of the stoma (H) and the time after operation was found.

#### ***The Effect on Pharyngeal Reconstruction.***

Statistically significant differences were found between the reconstructed and the nonreconstructed group. The group in which a pharyngeal reconstruction was



carried out had a 5.70 mm larger depth of the upper side of the stoma ( $p = .01$ ; 95% CI, 1.28 to 10.11 mm). No other influencing factors were demonstrated.

***The Effect of Neck Dissection.***

A statistically significant difference was found between the nondissected and the bilaterally dissected group. The nondissected group showed a smaller horizontal stoma diameter (H) with a mean difference of 3.0 mm ( $p = .00$ ; 95% CI, 1.2–4.7 mm) and a smaller vertical stoma diameter (V) with a mean difference of 3.7 mm ( $p = .00$ ; 95% CI, 1.6–5.9 mm) as compared to the bilaterally dissected group. Furthermore, statistically significant difference was found between the unilaterally and the bilaterally dissected group. The bilaterally dissected group showed a smaller vertical stoma diameter (V) with a mean difference of 3.64 mm ( $p = .02$ ; 95% CI, 0.81–6.46 mm) as compared to the bilaterally dissected group. Finally, we compared the peristomal geometry as a result of the type of neck dissection (radical, modified, selective, and absence of lymph node dissection). Statistically significant differences were found between the nondissected group and the selective lymph node dissected group: the selective lymph node dissected group showed a 3.49 mm larger horizontal (H) stoma diameter ( $p = .01$ ; 95% CI, 0.61–6.78 mm) and a 4.01 mm larger vertical (V) stoma diameter ( $p = .01$ ; 95% CI, 0.41–6.62 mm) as compared to the nondissected group. Furthermore, the selective lymph node dissected group showed a 13.0 mm larger fold-to-fold (F) distance ( $p = .02$ ; 95% CI, 1.15–24.86 mm) as compared to the nondissected group. Statistically significant difference was found between the modified dissected group and the selective lymph node dissected group: the selective lymph node dissected group showed a 8.27 mm larger lower stoma (d) depth ( $p = .02$ ; 95% CI, 0.73–15.82 mm) as compared to the modified dissected group.

***The Effect of Radiotherapy.***

Statistically significant differences were found between the radiotherapy and the nonradiotherapy group. The group in which a radiotherapy was carried out had a 7.7 mm smaller distance between the SCM or skin folds (F) as compared to the nonradiotherapy group ( $p = .01$ ; 95% CI, 1.5 to 13.8 mm). Furthermore, the group in which a radiotherapy was carried out had a 5.7 mm smaller distance between the right border of the stoma until SCM or skin fold (R) as compared to the nonradiotherapy group ( $p = .01$ ; 95% CI, 2.1 to 9.7 mm). No other influencing factors were found.

**Multivariate Analysis.**

Multivariate analysis was made to perform trade studies across all studied dimensions while taking into account the effects of all 6 variables. However, multivariate analysis was not able to signify these effects, due to missing variables.

**Discussion**

Although 3-dimensional evaluation of the (peri-)stoma using stereophotogrammetry or laser scanning is well known, proven<sup>22</sup>, and was available in-house, we found this was of no practical and additional use in a worldwide study as not all medical centers had access to these techniques, and as these techniques are just a storage medium in between the anatomy and the actual measurement. Our proposed measurement protocol can also easily be carried out on a digital image of the patient. Our attempts to model the peristomal area were, therefore, performed in a relatively low-tech manner using a Vernier caliper and flexible ruler. This was sufficient to gain all 10 parameter values in a reliable way and omits 3-dimensional scanning which only results in an image but no parametrical values. It was assumed that when removing more trachea rings during total laryngectomy, more traction was carried out on the skin surrounding the stoma. However, in contrast to our expectations, the group of patients having 4 trachea rings removed did not have a deeper stoma (described in terms of  $u$  [depth of upper border of the stoma opening] and  $d$  [depth of lower border of the stoma opening]) when compared to the group with 2 trachea rings removed. This could suggest that the surgeon is not limited in a choice between 2 and 4 tracheal rings to be removed with respect to the stomal geometry. When evaluating the measurements of the SCM groups, it was assumed that incision of the sternal attachment of the SCM provided a more flat peristomal area, better suited for today's most used flat peristomal adhesive patches. Although the fold-to-fold distance seems larger, no significantly shallower stomas were found in the group where incision of the SCM was made. As a result, it is not demonstrated that cleaving the SCM during laryngectomy will result in a geometrically flatter stoma.

Most clinicians familiar with laryngectomy patients are known with the phenomenon of a shrinking stoma after surgery. This occurrence could only be regained in our data in the vertical diameter ( $V$ ) of the stoma. In addition, with respect to radiotherapy, this phenomenon could not be shown. However, it must



be noted that measurements were carried out on 1 single outpatient day. Also, preceding dilatation of the stoma opening was not taken into account in this study.

Next, the influence of pharyngeal reconstruction on the peristomal geometry was studied. The lower border (d) did not significantly alter when comparing the 2 groups. However, the depth of the upper border of the stoma (u) proved to be significantly increased by as much as 5.70 mm. The measurement (u) was defined as the distance from the most superior edge of the stoma to the plane over the first interruptions lateral to the stoma. It must be noted that reconstruction is mainly performed above the level of the stoma. This could account for a larger upper stoma depth (u). Furthermore, the location of the lower border of the stoma (d) is anchored by the framework of the sternum and clavícula and, therefore, seems not to move as much as the upper border.

A multivariate analysis was carried out for all factors, but due to missing variables, no additional results could be taken into account. Furthermore, in this worldwide multicenter study, no conclusions could be drawn upon stoma geometry between different ethnic groups.

## Conclusion

These new data describing the tracheal opening and soft tissue contours around the trachea stoma do indicate the variety of influences affecting the peristomal area after total laryngectomy. Surprisingly, SCM cleavage did not seem to influence the depth of the peristomal area in this worldwide study. Therefore, it is not demonstrated that cleaving the SCM at the time of a laryngectomy will result in a geometrically flatter stoma. Furthermore, it seems that the number of removed tracheal rings during laryngectomy does not influence the depth of the stoma. Based on the results of our worldwide multicenter studies, a new adhesive automatic tracheostoma valve fixation patch is being developed. Our intent in developing a new biomedical device is not to adjust the patient to the device, but to engineer the device to fit the patient.

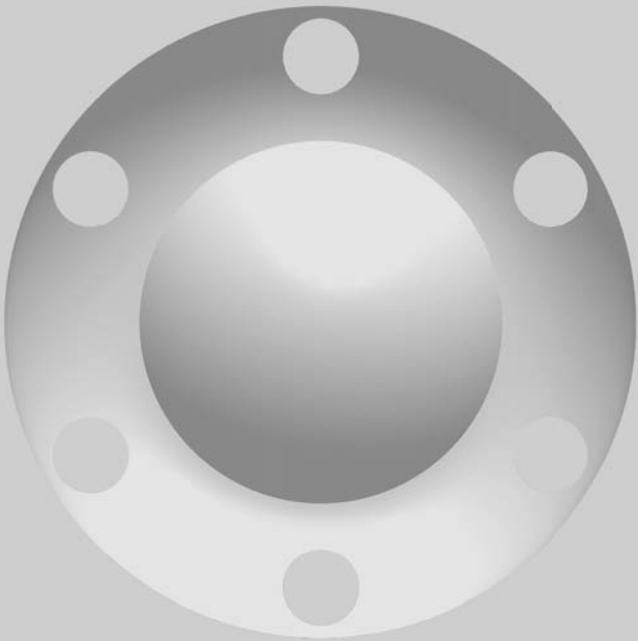
## Acknowledgments

We would like to acknowledge W.J. van der Meer for his help on patient imaging.

## Reference List

1. Marioni G, Marchese-Ragona R, Lucioni M, Staffieri A. Organ-preservation surgery following failed radiotherapy for laryngeal cancer. Evaluation, patient selection, functional outcome and survival. *Curr Opin Otolaryngol Head Neck Surg* 2008;16:141-146.
2. Kaanders JH, Hordijk GJ. Carcinoma of the larynx: the Dutch national guideline for diagnostics, treatment, supportive care and rehabilitation. *Radiother Oncol* 2002;63:299-307.
3. Brown DH, Hilgers FJ, Irish JC, Balm AJ. Postlaryngectomy voice rehabilitation: state of the art at the millennium. *World J Surg* 2003;27:824-831.
4. Debruyne F, Delaere P, Wouters J, Uwents P. Acoustic analysis of tracheo-oesophageal versus oesophageal speech. *J Laryngol Otol* 1994;108:325-328.
5. Pauloski BR, Fisher HB, Kempster GB, Blom ED. Statistical differentiation of tracheoesophageal speech produced under four prosthetic/occlusion speaking conditions. *J Speech Hear Res* 1989;32:591-599.
6. Robbins J, Fisher HB, Blom EC, Singer MI. A comparative acoustic study of normal, esophageal, and tracheoesophageal speech production. *J Speech Hear Disord* 1984;49:202-210.
7. Hilgers FJ, Balm AJ. Long-term results of vocal rehabilitation after total laryngectomy with the low-resistance, indwelling Provox voice prosthesis system. *Clin Otolaryngol Allied Sci* 1993;18:517-523.
8. Van Weissenbruch R, Albers FW. Vocal rehabilitation after total laryngectomy using the Provox voice prosthesis. *Clin Otolaryngol Allied Sci* 1993;18:359-364.
9. Hilgers FJ, Schouwenburg PF. A new low-resistance, self-retaining prosthesis (Provox) for voice rehabilitation after total laryngectomy. *Laryngoscope* 1990;100:1202-1207.
10. Smith BE. Aerodynamic characteristics of Blom-Singer low-pressure voice prostheses. *Arch Otolaryngol Head Neck Surg* 1986;112:50-52.
11. Zijlstra RJ, Mahieu HF, Lith-Bijl JT, Schutte HK. Aerodynamic properties of the low-resistance Groningen button. *Arch Otolaryngol Head Neck Surg* 1991;117:657-661.
12. Op de Coul BM, van den Hoogen FJ, van As CJ, et al. Evaluation of the effects of primary myotomy in total laryngectomy on the neoglottis with the use of quantitative videofluoroscopy. *Arch Otolaryngol Head Neck Surg* 2003;129:1000-1005.
13. Mahieu HF, Annyas AA, Schutte HK, van der Jagt EJ. Pharyngoesophageal myotomy for vocal rehabilitation of laryngectomees. *Laryngoscope* 1987;97:451-457.
14. Singer MI, Blom ED. Selective myotomy for voice restoration after total laryngectomy. *Arch Otolaryngol* 1981;107:670-673.
15. Grolman W, Schouwenburg PF, de Boer MF, Knegt PP, Spoelstra HA, Meeuwis CA. First results with the Blom-Singer adjustable tracheostoma valve. *ORL J Otorhinolaryngol Relat Spec* 1995;57:165-170.
16. van den Hoogen FJ, Meeuwis C, Oudes MJ, Janssen P, Manni JJ. The Blom-Singer tracheostoma valve as a valuable addition in the rehabilitation of the laryngectomized patient. *Eur Arch Otorhinolaryngol* 1996;253:126-129.
17. ten Hallers EJ, Marres HA, Rakhorst G, et al. Difficulties in the fixation of prostheses for voice rehabilitation after laryngectomy. *Acta Otolaryngol* 2005;125:804-813.
18. Hilgers FJ, Ackerstaff AH, van As CJ, Balm AJ, Van den Brekel MW, Tan IB. Development and clinical assessment of a heat and moisture exchanger with a multi-magnet automatic tracheostoma valve (Provox FreeHands HME) for vocal and pulmonary rehabilitation after total laryngectomy. *Acta Otolaryngol* 2003;123:91-99.
19. Op de Coul BM, Ackerstaff AH, van As-Brooks CJ, et al. Compliance, quality of life and quantitative voice quality aspects of hands-free speech. *Acta Otolaryngol* 2005;125:629-637.
20. Lemon JC, Lewin JS, Martin JW, Chambers MS. Custom modification of the Blom-Singer tracheostoma valve housing. *J Prosthodont* 2003;12:17-20.
21. Meyer JBJ, Knudson RC. Fabrication of a custom recessed tracheostoma valve retainer for the total laryngectomy patient. *J Prosthet Dent* 1990;63:182-186.
22. Dirven R, Hilgers FJ, Plooi J, et al. 3D stereophotogrammetry for the assessment of tracheostoma anatomy. *Acta Otolaryngol* 2008:1-7.





# Does the patch fit the stoma? A study on peristoma geometry and patch use in laryngectomized patients<sup>†</sup>

E.B. van der Houwen MSc<sup>1</sup>, T.A. van Kalker MD<sup>2</sup>, W.J. Post PhD<sup>3</sup>,  
F.J.M. Hilgers MD, PhD<sup>4</sup>, B.F.A.M. van der Laan MD, PhD<sup>2</sup>, G.J. Verkerke MSc, PhD<sup>1,5</sup>

Clinical Otolaryngology. 2011 Jun; Volume 36, Issue 3, Pages 209-302.

<sup>1</sup>Dept of Biomedical Engineering and the <sup>2</sup>Dept of Otorhinolaryngology/Head&Neck Surgery,  
University Medical Center Groningen, University of Groningen, A. Deusinglaan 1, 9713AV,  
Groningen, the Netherlands

<sup>3</sup>Dept of Epidemiology, University Medical Center Groningen, the Netherlands

<sup>4</sup>The Netherlands Cancer Institute Amsterdam, and the Institute of Phonetic Sciences, and the  
Academic Medical Center, University of Amsterdam, the Netherlands

<sup>5</sup>Faculty of Engineering Technology, University of Twente, the Netherlands

<sup>†</sup>Presented at the EGFL 2009 conference, 21-24th of October, 2009. Lisbon, Portugal.



## Introduction

Laryngectomy is currently the most frequently performed treatment for advanced-stage laryngeal carcinoma. The patient's initial inability to speak and the lack of air pre-conditioning have both been shown to decrease quality of life<sup>2</sup>.

To enable speech, finger operated Heat-and-Moisture-Exchange (HME) filters and, for hands-free speech, Automatic tracheoStoma Valves (ASV's)<sup>3,4,5,6</sup> have been on the market for some time, or are in development<sup>7</sup>. Heat and moisture exchange (HME-)filters effectively improve the tracheal climate<sup>2,8</sup> and generally benefit laryngectomized patients<sup>9,10</sup>. In general, two widely accepted fixation methods are available for attachment of ASV's and HME-filters to the stoma: intra-tracheal devices or adhesive stoma patches.

The use of patches, filters and valves varies. Literature suggests 78% compliance for a manually operated valve with HME-filter<sup>11</sup>, 78% for any stoma patch in general<sup>5</sup>, 70% for a patch with HME-filter<sup>10</sup> and 15-25%<sup>6,10,12</sup> compliance for daily use of an automatic speech valve. ASV's in particular are not widely used due to compliance issues.

ASV's exert considerably more stress on the attachment system than the manually occluded HME's during speech. With manual occlusion, the pneumatic pressure is countered by finger pressure, while in ASV's all speech pressure is exerted on the stoma interface. Poor fit, poor gluing and skin irritation (mostly related to the use of glue) are mentioned as the main reasons for not using ASV's<sup>3,5,12</sup>, and are all interface related. Currently, the only way to improve this is by casting a tailor-made ASV interface<sup>13,14</sup>, a laborious and expensive solution.

If we want to increase ASV use, this stoma interfacing needs to be improved. The unknown geometry of the stoma and peristoma however, hinders this development. Therefore we set up a study to obtain all information required to improve stoma interfacing. Improved adhesive patches will increase the use of these patches, their connected speech valves and HME-filters, and can significantly improve the quality of life in this patient group.

The study was split up into a clinical and a anthropometrical part, published in parallel. In the clinical paper we investigated the influence of the surgical procedure on the shape and size of the (peri) stoma<sup>17</sup>. This paper showed that the surgical approach where the sternocleidomastoid is incised in order to decrease the stoma depth is of very limited effect on the depth of the stoma, and therefore on the improvement of patch fit<sup>17</sup>. It also showed that the number of removed

tracheal rings is of no influence of the stoma depth. The clinical paper presents only the stoma geometry for the entire measured population.

This anthropometrical paper presents not only the geometry of the (peri)stoma of laryngectomized patients in general, but especially the difference in stoma geometry in patch users and non-patch users specifically. Commercially available adhesive patches were also measured and compared to the collected stoma geometry, to investigate a mismatch between peristoma shape of non-patch users and the commercially available patch shape. This paper is the first study ever to present this difference in peri stoma geometry. With this data it is possible to develop stoma interfaces, e.g. adhesive patches, specifically for this large group of unaddressed patients, improving HME and ASV use with all the associated increase in quality of life.



## Methodology

### Patients

A total of 191 patients (10% female) from various institutions in 8 countries (The Netherlands (n = 84), Belgium (n = 20), France (n = 12), New Zealand (n = 5) Italy (n = 6), Spain (n = 17), Portugal (n = 26) and Egypt (n = 21) were randomly included from routine out-patient clinic visits. The average age was 65.5 years (range 35-92 years). Inclusion criteria were total laryngectomy at least 1 year prior to the study. Exclusion criteria were irritation of the (peri)stoma, tumour recurrences or poor wound healing in such a way that measuring the (peri)stoma was deemed unhygienic, painful, or difficult. Data from all institutions were pooled together to establish an homogeneous database, effectively spanning different institutes and surgeons, delivering the (peri)stomal geometry of an as large as possible population.

### Ethical considerations

This study was approved by all the respective institution's ethics committees. All included patients were scheduled for routine check-up (e.g. shunt valve changes) and signed informed consent forms.

### Methods

To characterise those geometrical parameters of the (peri)stoma that influence stoma interfacing we derived 10 parameters. More parameters would only slightly improve characterisation, but increase measuring time. The selected number

proved a good balance in practice. All patients and investigators completed a questionnaire. Photographic images were taken of each patient's neck to enable retrospective verification of measured data. All photos, measurements and classifications were done with the patient sitting upright in a chair. Measurements took about 30 minutes per patient.

The protocol used in this study consists of three parts.

direct measurement of the stoma and peristoma by means of a (tape) ruler (1 mm divisions) and Vernier Calliper (minimal accuracy 0.5 mm),

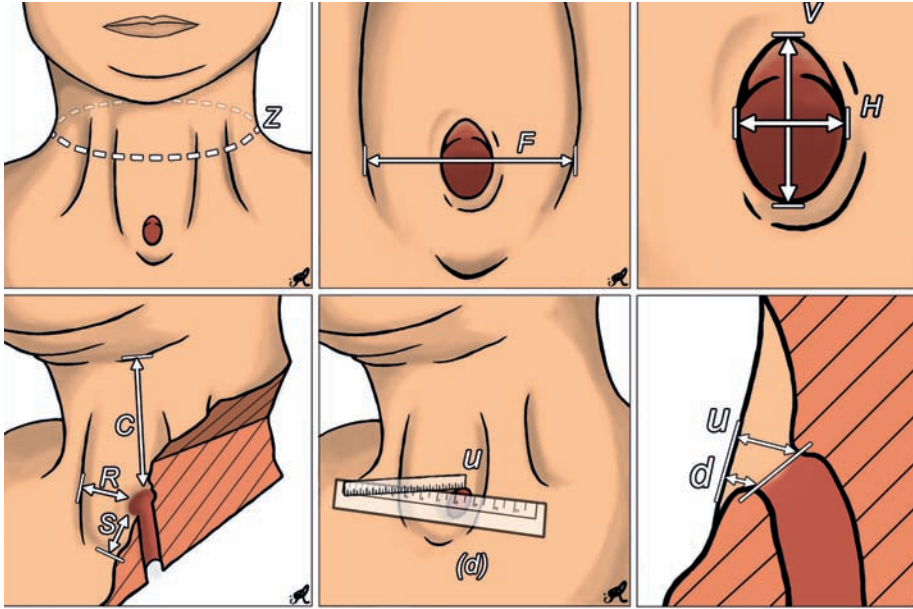
10 standardized digital pictures of the peristoma and neck,

a detailed questionnaire from which the patient's age and gender and three questions related to patch use ("do you use stoma stickers or patches?", "are adhesive patches financially reimbursed by your health care provider?" and "how long do the stickers/patches stay?") were used in this study.

In addition, the depth (defined as the distance from inner to outer rim perpendicular to the stoma) of adhesive patches from the three most popular brands (Blom-Singer (Helix Medical, Carpinteria, USA), Atos (Atos Medical, Hörby, Sweden) and Ceredas (Ceredas, Antony, France)) were measured with a Vernier Calliper (minimal accuracy 0.5 mm).

The applied surgical techniques, patient history and their influence on patch use and (peri)stoma geometry were presented in our clinical study<sup>17</sup>.

### Measured Parameters



**Figure 1.** Parameters of the patient's (peri)stoma (distance  $L$  omitted in this figure for clarity).

The following ten parameters were according to the diagram in Figure 1:

The collar size  $Z$  (circumference of the neck at stoma height).

The horizontal  $H$  and vertical  $V$  diameter of the stoma itself.

The area of uninterrupted, smooth, scar and crevice-free skin around the stoma is defined by the following parameters:

Distance fold-to-fold  $F$ : the horizontal distance (at stoma centre height) between the first interruptions on each side of the stoma, in most cases these folds are the sternocleidomastoid muscles (SCM). This distance is maximized at 100 mm: distances greater than 100mm are noted as 100mm.

Distance stoma-to-chin  $C$ : the distance from the stoma to the first upward interruption (often the base of the chin). This distance is maximized at 50 mm.

Distance stoma-to-sternum  $S$ : the distance downward from the stoma to the first interruption (often the jugular notch (the recession above the sternum). This distance is maximized at 50 mm.

Distance stoma-to-right-fold  $R$  and distance stoma-to-left-fold  $L$ : the horizontal distance between the stoma edge and the first fold proximal to the stoma (often the SCM) on the patients' right and left sides. This distance is maximized at 50 mm.

Superior stoma depth  $u$ : the distance from the most superior edge of the stoma to the plane over the first interruptions lateral to the stoma (often the depth of the deepest stoma edge seen from the plane over the SCM).

Inferior stoma depth  $d$ : the distance from the most inferior edge of the stoma to the plane over the first interruptions lateral to the stoma (often the depth of the most shallow stoma edge measured from the plane over the SCM).

### **Calculated parameters**

Four parameters are derived from the measured parameters: the ellipticity of the stoma  $\varepsilon$  ( $H/V$ ), the average stoma depth  $D_{ave}$  ( $(u+d)/2$ ), the area of the stoma  $A_{stoma}$  ( $H \times V \times \frac{1}{4} \times \pi$ ) and the inclination of the stoma relative to the proximal folds  $\alpha$ , in degrees ( $\arcsine((u-d)/V)$ ). A higher  $\alpha$ , designates a stoma leaning relatively backward and an  $\alpha$  of 0 designates a stoma parallel to the proximal protrusions of the SCM or proximal folds.

### **Statistical analysis**

All parameters were analyzed using SPSS version 16.0. Statistical analysis was mainly based on descriptive analysis. Normality of all parameters was checked visually using histograms and Q-Q plots and where needed the parameters were  $\log^{10}$ -transformed to achieve normality. In case of normality, equality of means of parameters was tested using the independent sample T-tests. In case of non-normality, parameters were tested using a Mann-Whitney non-parametric rank test. Relations between nominal parameters were investigated using the Pearson Chi-square test. A two-tailed p-value of  $<0.05$  was taken to indicate statistical significance.

All parameters were checked for extreme values (checked on the respective photos). Extremes were excluded from analyses. To assess the intra-observer variability, half of the patient population was measured twice by the same observer (see Table 4). The intra-observer agreement was calculated using kappa coefficients. Values for kappa between 0.61 and 0.80 denote substantial agreement and values higher than 0.80 denote almost perfect intra-observer agreement.

## **Results**

### **General results**

In all patients ( $n=191$ ), only 36% report the use of patches (Table 1). In four countries (Spain, Egypt, Italy and Portugal), patches are not financially reimbursed by health insurance. With these countries excluded, 58% of the patients ( $n=121$ ) report to use patches (Table 1). In the group of daily adhesive patch users (all countries included,  $n=56$ ), the mean patch *in situ* duration was 29.5 hours (33.3 hours for patients in reimbursed countries alone). Not all parameters were consistently available for all patients due to missing data and removed extreme values.

**Table 1.** Patch use in reimbursing and non-reimbursing countries.

	N	% patch users in total	% patch users in responders	% non responders
Reimbursing countries*	121	41	58	28
Non-reimbursing countries†	70	9	9	1
Total	191	29	36	18

\* The Netherlands (n = 84), Belgium (n = 20), France (n = 12) and New Zealand (n = 5)

† Italy (n = 6), Spain (n = 17), Portugal (n = 26) and Egypt (n = 21)

### **Normality of measured parameters**

All parameters were checked on normal distribution. Four parameters ( $C$ ,  $d$ ,  $R$  and  $L$ ) were not normally distributed. The parameters  $R$  and  $L$  were normally distributed after  $\log^{10}$ -transformation.

Descriptive statistics for the entire population are presented in Table 2.

**Table 2.** Geometry for the total population (all sizes in mm).

\*not normally distributed (median and variance presented). †5<sup>th</sup> percentile. ‡95<sup>th</sup> percentile.

	Valid N	Mean (SD)	Min.	Max.	P5 <sup>†</sup>	P95 <sup>‡</sup>
Circumference of the neck $Z$	166	367 (33)	280	440	310	420
Horizontal stoma diameter $H$	186	13 (4)	3	23	8	20
Vertical stoma diameter $V$	188	17 (5)	6	33	10	25
Distance Fold to Fold $F$	187	38 (16)	10	100	14	70
Distance Stoma to Sternum $S$	188	24 (9)	3	50	10	40
Superior stoma depth $u$	175	13 (9)	0	50	0	32
Mean stoma depth $D_{ave}$	175	13 (8)	0	35	1	28
Area of the stoma (mm <sup>2</sup> ) $A_{stoma} = (H \times V) / 4 \times \pi$	186	186 (88)	20	506	71	346
Ellipticity of the stoma $\epsilon = (H/V)$	186	0.8 (0.2)	0.3	1.5	0.5	1.1
Stoma inclination $\alpha$ (degrees)	166	3 (22)	-91	91	-32	37
Distance Stoma to Chin $C^*$	186	40 (240)	4	50	10	114
Distance stoma to patients' right fold $R^*$	184	17 (87)	3	82	7	45
Distance stoma to patients' left fold $L^*$	185	17 (88)	5	52	8	40
Inferior stoma depth $d^*$	175	11 (65)	0	35	0	27

### **(Peri)stoma geometry and adhesive patch use**

Geometry in relation to patch use was only investigated in patients from reimbursing countries that responded to the question about patch-use (n=84). 5 Parameters show a difference in geometry (Table 3) between patch users and non-patch users.



On average, patch users have thicker necks, a larger fold-to-fold ( $F$ ) distance, shallower and flatter peristomas (more parallel to the front of the neck). The  $\alpha$  in patch users was 30 degrees, compared to 91 degrees for non-patch users (P95 respectively 27 and 57 degrees inclination, Table 3).

**Table 3.** Significantly different geometry for patch users and non-patch users (Portugal, Egypt, Spain, and Italy excluded). All sizes in mm. †5<sup>th</sup> percentile. ‡95<sup>th</sup> percentile.

Patients that report patch use						
	Valid N	Mean (SD)	Min.	Max.	P5 <sup>†</sup>	P95 <sup>‡</sup>
Circumference of the neck $Z$	37	358 (30)	290	435	290	430
Distance Fold to Fold $F$	49	44 (23)	10	100	11	100
Superior stoma depth $u$	49	13 (10)	0	50	0	26
Mean stoma depth $D_{ave}$	49	13 (7)	0	35	0	24
Stoma inclination $\alpha$ (degrees)	45	1 (24)	-91	30	-45	27
Patients that report no patch use.						
	Valid N	Mean (SD)	Min.	Max.	P5 <sup>†</sup>	P95 <sup>‡</sup>
Circumference of the neck $Z$	30	381 (24)	340	420	340	415
Distance Fold to Fold $F$	37	34 (12)	10	60	11	55
Superior stoma depth $u$	37	21 (11)	0	40	2	37
Mean stoma depth $D_{ave}$	37	18 (9)	0	34	2	34
Stoma inclination $\alpha$ (degrees)	33	20 (24)	-15	91	-15	57
Total responding patients						
	Valid N	Mean (SD)	Min.	Max.	P5 <sup>†</sup>	P95 <sup>‡</sup>
Circumference of the neck $Z$	67	369 (30)	290	435	330	415
Distance Fold to Fold $F$	86	40 (20)	10	100	11	76
Superior stoma depth $u$	86	17 (11)	0	50	0	35
Mean stoma depth $D_{ave}$	86	15 (9)	0	35	0	29
Stoma inclination $\alpha$ (degrees)	78	9 (26)	-91	91	-38	51

### **Adhesive patch depth**

An investigation of the three most popular brands on the market showed that most tracheostoma adhesive patches are flat. The only concave types (The Blom-Singer BE6038 and BE6039, Helix Medical, USA and the Atos XtraBase, Atos Medical, Sweden), are around 7 mm deep.

### **Assessment of intra-observer reliability**

Calculated kappa coefficients (Table 4) show almost perfect intra-observer agreement for *V* and *C* (kappa values of respectively 0.875 and 0.881). Other measurements show substantial agreement (0.630 to 0.783) (see Table 4).

**Table 4.** intra-observer reliability assessed by kappa coefficient

Parameter	Kappa coefficient (valid cases)
Circumference of the neck <i>Z</i>	0.630 (94)
Horizontal stoma diameter <i>H</i>	0.698 (92)
Vertical stoma diameter <i>V</i>	0.875 (86)
Distance Fold to Fold <i>F</i>	0.783 (90)
Distance Stoma to Chin <i>C</i>	0.881 (92)
Distance Stoma to Sternum <i>S</i>	0.689 (93)
Distance stoma to patients' right fold <i>R</i>	0.754 (90)
Distance stoma to patients' left fold <i>L</i>	0.751 (90)
Superior stoma depth <i>u</i>	0.735 (92)
Inferior stoma depth <i>d</i>	0.725 (91)

## **Discussion**

### **Comparison with other studies**

Dirven *et al.* (2008)<sup>16</sup> measured (peri)stomas in a small (n=20) Dutch population and found similar stoma sizes and stoma depths: *H*, *V*, *L* and *R* respectively 14.7, 19, 15.5 and 16 mm (Dirven 2008) versus 13, 17, 17 and 17 mm (this study).

The patient compliance with tracheostoma devices (measured as patch use) in this study (58%) is considerably lower than the values found in literature (78% and 70%)<sup>5,11,10</sup>. Apart from differences in (peri)stoma geometry, the personal preferences of the practitioners, culture and climate might also have effects on patch use. The geometrical differences found in this paper are highly significant ( $p \leq 0.016$ ) and clinically relevant.

### **Key findings**

The major factor which determines patch-use is the financial reimbursement of tracheostoma devices (58% compliance vs. 9% in non-reimbursing countries). Thus a major improvement in patch use could be obtained with less expensive patches (and connected devices) or (improved) financial reimbursement systems. No significant difference in gender amongst patch users was found, though the low





number of female patients in this group ( $n=12$ ) rendered fair comment impossible. We also investigated the influence of wrinkles and folds (scars) and found these factors of no significant influence on overall patch use. No relationship between patch use, mucus/phlegm production, *in situ* patch duration and average stoma depth was found.

Table 3 shows that the peristoma in patch users are considerably more shallow ( $D_{ave} = 13$  mm) than the peristoma in non-patch users ( $D_{ave} = 18$  mm). This can be largely attributed to the superior stoma depth ( $u$ ) and less to the Inferior stoma depth ( $d$ ). This suggests a change in the stoma plane angle: stomas of patch users are considerably more parallel to the front of the neck than those of non-patch users. Thus the peristoma *overall depth* and *relative stoma angle* determine the quality of patch accommodation.

Considering the mean stoma depth of 13 mm in the total patient population with the 7 mm of the commercially available deepest stoma patches, the high number of interface problems<sup>3,5,6</sup> in literature can be fully explained by our presented data. This clearly indicates that adjusting the patch size and shape to the (peri)stoma geometry is very likely to benefit compliance and successful use of these devices. The measurements also show that the overall space around the stoma is important to patch accommodation. In patch users, the distance  $F$  is larger than in non-patch users. Yet the distances  $L$  and  $R$ , or the distance  $C$  or  $S$ , show no significant differences. Thus the area of the peristoma in non-patch users is smaller and more concave. Given this, the area for glue retention decreases. With  $L$ ,  $R$ ,  $C$  and  $S$  still showing ample space for a more concave patch, developing a patch that makes use of this space is clearly possible.

### ***Clinical and practical implications***

We found that non-patch users have deeper and more inclined stomas than patch users. Thus either the patch should be altered to fit these peristomas or an effort should be made to decrease the depth of the peristoma and the inclination of the stoma during surgery. The latter, by means of incision of the SCM, is being done in some institutions. However, as we have shown in our clinical paper, the use of this procedure has only very limited effect<sup>17</sup>. Alteration of the patch design should be preferred over alteration of the patient's anatomy and should at least be pursued before considering the drastic alternative. Two examples on how to improve the design of an adhesive patch for better fit are supplied in the Recommendations S1.

***Intra-observer reliability***

The presented parameters are measurements of soft tissue, on which landmarks for reproducible measurements have intrinsic limitations. Despite these challenges, the intra-observer reliability showed high levels of agreement between the different measurements.

**Conclusions**

This study shows that there is a wide variation in (peri)stoma anatomy, a wide variability in the use of stoma patches, and a difference between the (peri)stomal anatomy and shape of current adhesive patches.

Patch use seems to be associated with stoma *depth* and with stoma *inclination*. Patch users have relatively shallow, parallel stomas (parallel to the frontal structures of the neck), while non-patch users have deeper, more inclined stomas (tilted backward). Patch users have on average thicker necks and a larger fold-to-fold distance. The distances  $R$  and  $L$  do not differ between patch users and non-patch users, nor do they differ between different stoma depths.

This study of a broad laryngectomized patient population, is the first to clearly demonstrate the different peristoma geometries for patients that can, and patients that cannot use patches, and deliver the geometry to improve this situation. Deeper patches, adjusted to the geometry of patients that are currently without adhesive patches, are a simple and much needed step to increase patch use. A step that can dramatically increase the use of patches, their connected speech valves, and HME-filters, and by doing so will significantly improve the quality of life in this patient group.

**Acknowledgments**

The would like to acknowledge the following for participating in the study: M.E. Duits (Dept of Otorhinolaryngology/Head&Neck Surgery, University Medical Center Groningen, University of Groningen, A. Deusinglaan 1, 9713AV, Groningen, the Netherlands), A. Hebe and J. Olias MD PhD (Dept of ORL, Instituto Português de Oncologia de Lisboa, Lisboa, Portugal), B.E. Mostafa MD (Dept of ORL, HNS, Faculty of Medicine, Ain-Shams University, Cairo, Egypt), G. Lawson MD (Dept of ORL, HNS, University Hospital of Louvain and Université Catholique de Louvain, Belgium),



Z. Martinez MD (Dept of ORL, Hospital Donostia, San Sebastián, Spain), V. Woisard MD (Dept of ORL, HNS, University Hospital of Rangueil Larrey, Toulouse, France), G. Marioni MD (Dept of Medical & Surgical Specialties, Section of Otolaryngology, University Hospital Padova, Italy), D. Ruske MD (ORL Head and Neck Department, Dunedin Hospital, Otago, New Zealand ), P.Schultz MD Dept of ORL, HNS, University Hospital Strasbourg, France).

We would also like to acknowledge W.J. van der Meer for his help on patient scanning, R.S. Koolschijn for Figure 1 and D. Ruske and J. Younes for proof reading.

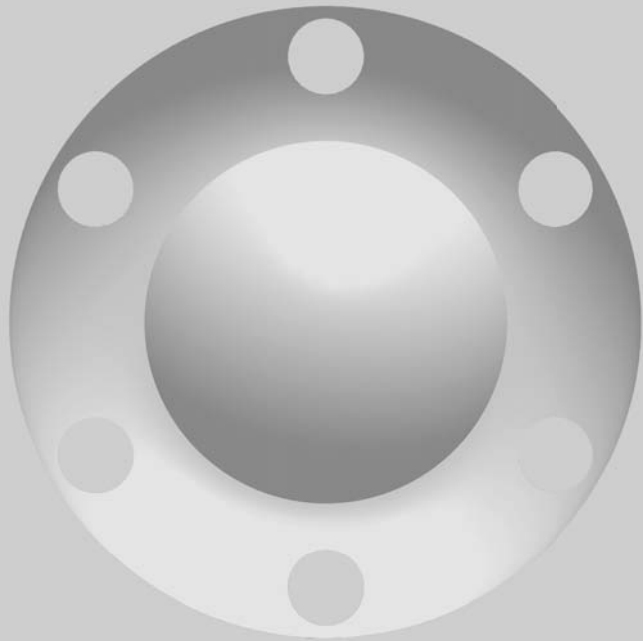
## Reference List

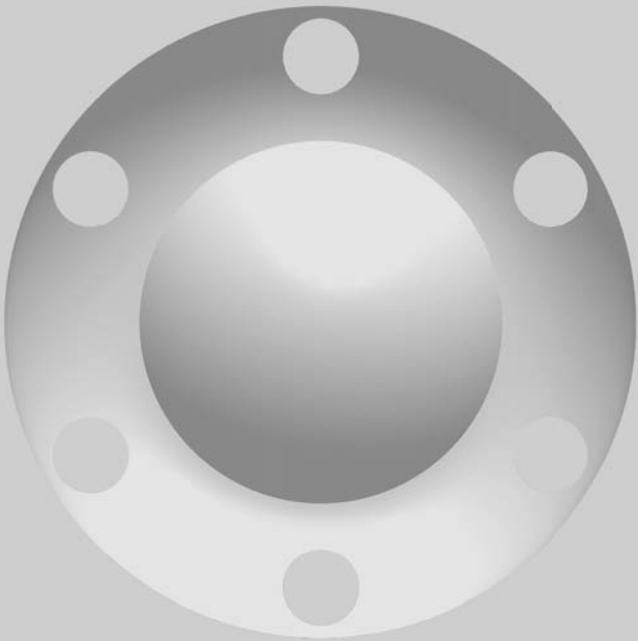
1. Kaanders JH and Hordijk GJ. (2002) Carcinoma of the larynx: the Dutch national guideline for diagnostics, treatment, supportive care and rehabilitation. *Radiother.Oncol.* 3. 299-307
2. Hilgers FJ, Aaronson NK, et al. (1991) The influence of a heat and moisture exchanger (HME) on the respiratory symptoms after total laryngectomy. *Clin.Otolaryngol.Allied Sci.* 2. 152-156
3. ten Hallers EJ, Marres HA, et al. (2005) Difficulties in the fixation of prostheses for voice rehabilitation after laryngectomy. *Acta Otolaryngol.* 8. 804-813
4. van den Hoogen FJ, Meeuwis C, et al. (1996) The Blom-Singer tracheostoma valve as a valuable addition in the rehabilitation of the laryngectomized patient. *Eur.Arch.Otorhinolaryngol.* 3. 126-129
5. Hilgers FJ, Ackerstaff AH, et al. (2003) Development and clinical assessment of a heat and moisture exchanger with a multi-magnet automatic tracheostoma valve (Provox FreeHands HME) for vocal and pulmonary rehabilitation after total laryngectomy. *Acta.Otolaryngol.* 1. 91-99
6. Lorenz KJ, Groll K, et al. (2007) Hands-free speech after surgical voice rehabilitation with a Provox((R)) voice prosthesis: experience with the Provox FreeHands HME tracheostoma valve((R)) system. *Eur.Arch. Otorhinolaryngol.* 2. 151-157
7. Geertsema AA, Boonstra CW, et al. (1999) Design and test of a new tracheostoma valve based on inhalation. *Archives.of.Otolaryngology.Head.and.Neck.Surgery.* 6. 622-626
8. Keck T, Durr J, et al. (2005) Tracheal climate in laryngectomees after use of a heat and moisture exchanger. *Laryngoscope.* 3. 534-537
9. Moerman M, Lawson G, et al. (2003) The Belgian experience with the cyranose heat moisture exchange filter. A multicentric pilot study of 12 total laryngectomees. *Eur.Arch.Otorhinolaryngol.* 6. 301-303
10. Bien S, Okla S, et al. (2009) The effect of a Heat and Moisture Exchanger (Provox((R)) HME) on pulmonary protection after total laryngectomy: a randomized controlled study. *Eur.Arch.Otorhinolaryngol.*
11. Ackerstaff AH, Hilgers FJ, et al. (1998) Long-term compliance of laryngectomized patients with a specialized pulmonary rehabilitation device: Provox Stomafilter. *Laryngoscope.* 2. 257-260
12. Op de Coul BM, Ackerstaff AH, et al. (2005) Compliance, quality of life and quantitative voice quality aspects of hands-free speech. *Acta Otolaryngol.* 6. 629-637
13. Lemon JC, Lewin JS, et al. (2003) Custom modification of the Blom-Singer tracheostoma valve housing. *J.Prosthdont.* 1. 17-20
14. Meyer JBJ and Knudson RC. (1990) Fabrication of a custom recessed tracheostoma valve retainer for the total laryngectomy patient. *J.Prosthet.Dent.* 2. 182-186
15. Dirven R, Kooijman PG, et al. (2010) An external neck brace to support the peristomal fixation of an automatic stoma valve (ASV): 3D stereophotogrammetrical assessment. *Acta Otolaryngol.* 7. 851-858
16. Dirven R, Hilgers FJ, et al. (2008) 3D stereophotogrammetry for the assessment of tracheostoma anatomy. *Acta Otolaryngol.* 11. 1248-1254
17. van Kalker TA, van der Houwen EB, et al. (2010) A worldwide, Multi Center Study of Peristomal Geometry and Morphology in Laryngectomees and its Clinical Effects. (in press). *Head & Neck*





# A new stoma patch





# 4

## The best tracheostoma patch adhesives. In Vitro comparison of 5 adhesive systems.

T.A. van Kalkeren MD<sup>1</sup>, E.B. van der Houwen MSc<sup>2</sup>, R. Mencke BSc<sup>1,2</sup>, G.J. Verkerke MSc, PhD<sup>2,3</sup>, B.F.A.M. van der Laan MD, PhD<sup>1</sup>

Submitted

<sup>1</sup>Dept of Otorhinolaryngology/Head&Neck Surgery and the <sup>2</sup>Dept of Biomedical Engineering, University of Groningen, University Medical Center Groningen, A. Deusinglaan 1, 9713AV, Groningen, the Netherlands

<sup>3</sup>Faculty of Engineering Technology, University of Twente, the Netherlands



## Introduction

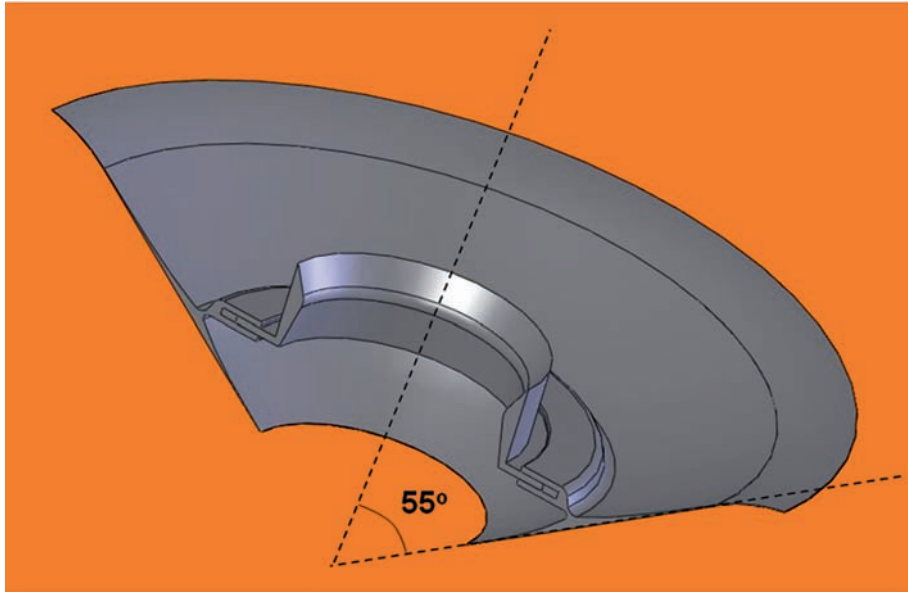
A total laryngectomy is indicated in case of advanced laryngeal carcinoma or residual disease after primary radiotherapy. After extirpation of the larynx, a tracheostoma is created ventrally in the neck to facilitate breathing. Rehabilitation of laryngectomy patients ideally consists of the application of shunt valves to restore speech and Heat- and Moisture Exchange filters (HMEs)<sup>1,2</sup> to restore most nasal functions. HMEs decrease involuntary coughing, airway irritation and excessive mucus production. Furthermore, the inhaled air is filtered, heated, and moisturised. They require placement in front of, and attachment to the tracheostoma. Voice supporting aids such as tracheostoma valves (TSVs)<sup>3,4</sup> may also need to be positioned in front of the tracheostoma. Both HMEs and TSVs are attached to the tracheostoma by means of an adhesive patch, also referred to as stoma patch, of which the current flat shaped ones perform dissatisfying, up to the point that in combination with a TSV only 25-30%<sup>2,5,6</sup> of all patients use these patches on a daily basis. The main reasons for the lack of utilisation are poor fit (the current tracheostoma patches are flat and presuppose a similar peristomal shape), poor adhesion capacity, allergies and skin irritation<sup>1,7</sup>. The recently (2012) introduced Provox StabiliBase partially addresses this, by being convex in shape<sup>8</sup>. It uses the same adhesive as the Provox Flexiderm as discussed in this study.

Studying the peristomal skin geometry has yielded elaborate data on size, shape and state of stomas<sup>9</sup>. A significant difference was found between patch users and non-patch users concerning the opening angle, the mathematical term for the top angle of a cone, of the patch (Figure1)<sup>10</sup>.

Adhesive capacity is dependent on the substrate properties, the type of adhesive, and the direction, size, and duration of the force caused by the exerted pressure. During physiologic speech, the endotracheal pressure varies from 2.0 to 3.9 kPa<sup>11</sup> and during loud speech, this pressure varies between 4.9 and 6.5 kPa<sup>12</sup>. Pressures during coughing can rise up to 21 kPa<sup>13</sup>.

Several adhesives are used on a regular base. However, their adhesive capacity has never been compared.

The aim of this study was to determine the maximum pressure that different (over-the-counter) adhesives can withstand compared to commercial patch adhesives. For that reason a selection of adhesives was studied.



**Figure 1.** Showing the opening angle of the patch.

## Materials and method

In total 5 different patch/adhesive combinations were tested :

1. Provox Adhesive FlexiDerm Oval (Atos Medical, Sweden)
2. Provox Adhesive OptiDerm Oval (Atos Medical, Sweden)
3. Ceredas Adhésif Double Face (Ceredas, Anthony, France)
4. Blom-Singer TrueSeal Adhesive Housing (Helix Medical, Carpinteria, USA)
5. Principality Original Adhesive G601 (Principality Medical Limited in Rogerstone, United Kingdom), applied on a prepared Atos FlexiDerm patch; the original adhesion layer was covered with a thin piece of paper to which the G601 adhesive was applied. G601, contrary to the other adhesion systems, needs to be applied shortly before use.

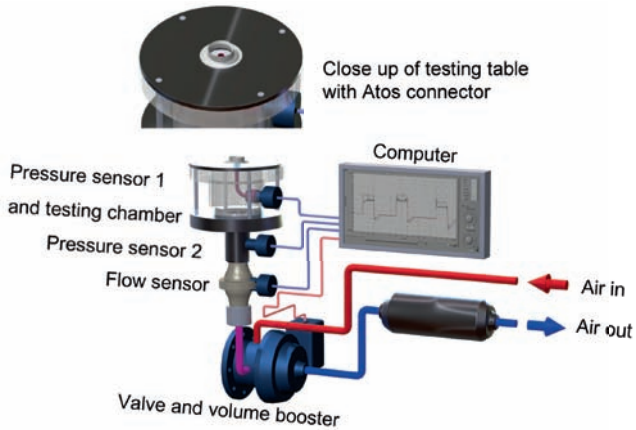
From every patch/adhesive combination 14 samples were tested. All patches were cut to an equal outer diameter. All inner diameters were similar in size with the exception of the Ceredas patch, with an inner diameter of 30 mm as compared to 23 mm of the remaining patches.

The maximum pressure a stoma patch can withstand was tested using the Pneumatics Simulator (PS); a device that can simulate respiratory patterns (Figure 2a and 2b).

To test the patches an artificial skin was made. For that reason 12 Bellamy skins were prepared<sup>14</sup>. This three-layered artificial skin possesses viscoelastic properties comparable to human skin. One artificial skin can be used six times, 12 artificial skins were used in total. The order of the tested patches was randomly distributed on the skins. Alternating the order of using the patches on the artificial skins was done to control for possible wearing off effects.

In preparation for the experiment, all patches were cut circular to the same outer diameter (71 mm) in order to create an equal adhesion area. The skins were fixated and slightly stretched over a heated (36 degrees Celsius) testing table. The bottom side was covered with a thin film of liquid soap, facilitating free lateral movement between the skin and the table. The center of the skin was also fixated with a hollow clamp: the simulator's tracheostoma. After removing the backing, the patch was applied to the skin over the clamp (Figure 3) at the central hole, mimicking a patch applied to a stoma (Figure 3a and 3b). All patches were closed with an airtight plug.

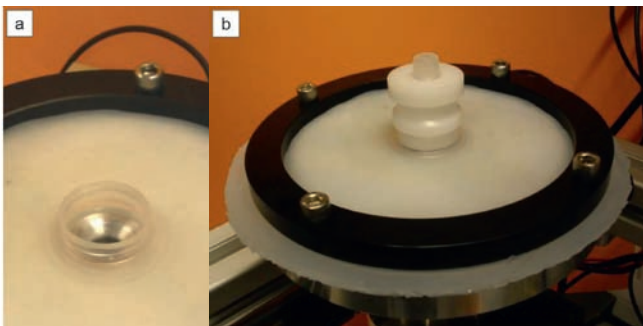
After placement, all patches were manually pressed to the artificial skin for 1 minute and a 5 minute waiting period was employed to ensure proper adhesion. Then, the PS increased the pressure at 0.05 kPa/s, from 0 kPa to 20 kPa. Using National Instruments LabVIEW 7.1 software (Austin, TX, USA), the pressure at which a first blister formed was recorded and the pressure and flow at which the adhesive failed, i.e. an air tunnel formed and the pressure dropped. Blister time, the time until failure of the patch, was recorded using a stopwatch. After failing of the adhesive, the patch was removed and the skin was cleaned with ethanol and allowed to dry before applying the next patch.



**Figure 2a.** A schematic overview of the Pneumatics Simulator setup. This device can simulate respiratory patterns. Pressure and flow sensors connected to a computer log the exerted values. A widely used (Atos FlexiDerm/OptiDerm/Regular) flat connector is mounted on the testing table enabling connection of stomal aids, such as filters.



**Figure 2b.** The Pneumatics Simulator. An artificial skin was fixated to the table on the left (arrow).



**Figure 3a.** A stoma patch applied to the artificial skin over the central hole and the trumpet clamp. **3b. Experimental** setup, ready for measurements. The stoma patch is closed with a plug.



### Statistical analysis

To test whether the test adhesive, Principality G601, can be compared to commercially available types of adhesive, a sample size calculation yielded that 14 patches per group were needed for a power > 0.9 in order to show equality.

Data are presented as mean  $\pm$  standard deviation or as median [interquartile range] depending on the distribution. Normally distributed unpaired data were compared with the Student's t test or ANOVA (depending on the number of groups), non-normally distributed unpaired data were compared with the Mann-Whitney U test or the Kruskal-Wallis test (depending on the number of groups). Spearman's or Pearson's correlation coefficient was used, depending of the distribution of the data. A p value < 0.05 was considered significant. SPSS version 16.01 (SPSS Inc., Chicago, Illinois, USA) was used to analyse the data.

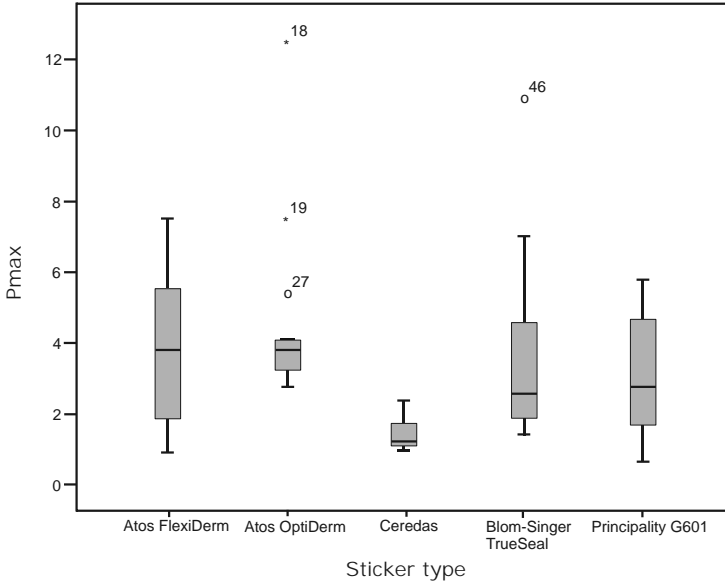
## Results

Maximum pressure, blister time, and failing time for each patch type are presented in Table 2. The Principality G601 displayed a median maximum pressure of 2.75 [1.66-4.83] seconds. Subsequent Mann-Whitney U tests yielded that the measured maximum pressures of the Principality G601 adhesive did not differ significantly from the results of the Atos FlexiDerm, Atos OptiDerm, or Blom-Singer TruSeal patches ( $p = 0.346$ ,  $p = 0.118$ ,  $p = 0.662$ , respectively), whereas it scored significantly better than the Ceredas patches ( $p = 0.004$ ) (Table 1 and Figure 4). The median blister time for Principality G601 was 48.5 [21.6-76.0] seconds. The median failing time for Principality G601 was 54.0 [30.1-94.6] seconds.

**Table 1.** The maximum pressure, blister time, and failing time plus [ranges] for each patch type.

Patch type	Median Maximum pressure [IQR*] (kPa)	Median blister time [IQR] (s)	Median failing time [IQR] (s)	Median time from blister to air tunnel formation [IQR] (s)
Atos FlexiDerm (n=14)	3.8 [1.88-5.58]	70.5 [27.5-103.8]	78.0 [40.8-119.0]	14.1 [3.0-16.4]
Atos OptiDerm (n=14)	3.8 [3.30-4.43]	52.5 [38.0-67.5]	74.1 [65.8-89.5]	20.0 [17.4-24.0]
Ceredas (n=14)	1.2 [1.10-1.85]	20.5 [13.8-29.8]	25.2 [21.4-34.9]	6.0 [4.8-8.1]
Blom-Singer TruSeal (n=14)	2.55 [2.0-5.13]	30.5 [23.3-67.1]	49.5 [37.0-102.6]	16.8 [13.8-30.3]
Atos FlexiDerm housing + Principality G601 (n=14)	2.75 [1.66-4.83]	48.5 [21.6-76.0]	54.0 [30.1-94.6]	7.8 [4.5-17.0]

\*IQR, interquartile range



**Figure 4.** The different patch types and the maximum pressure they withstood. Pmax denotes the maximum pressure in kPa. The Ceredas patches scored significantly lower than all other patches. The Blom-Singer TruSeal patches also scored significantly lower than the Atos OptiDerm patches ( $p = 0.027$ ).

Subtracting the blister time from the failing time yields the time it takes for the patch to fail completely after a blister has been formed (Table 2). With a median of 7.8 [4.5-17.0] seconds, the Principality G601 adhesive was statistically comparable to the Atos FlexiDerm and Ceredas patches ( $p = 0.565$  and  $p = 0.241$ , respectively) and scored significantly lower than the Atos OptiDerm and Blom-Singer TruSeal patches ( $p = 0.009$  and  $p = 0.002$ , respectively).

There was a correlation between maximum pressure and time between blister formation and air tunnel formation ( $p < 0.001$ ), with a correlation coefficient of 0.411.

After correcting for patch type by normalizing the maximum pressure with respect to the mean, there was a non-significant correlation ( $p = 0.398$ ) of 0.1 between the sequence number of a patch on a skin, and the normalized maximum pressure.

The principality G601 was tested by attaching a sheet to an Atos Flexiderm housing on which this glue was applied. We only encountered failure between the G601 glue and the skin, not between the sheet and the Flexiderm patch.



## Discussion

Because all patches were tested on an artificial skin, no effects of mucus, transpiration and movement of the skin were tested. This could lead to a prolonged adhesion time of all tested systems.

The Ceredas patch had a larger inner diameter of 30 mm as compared to 23 mm of the remaining patches. This could have influenced the adhesion performance in a negative manner. Mechanically one could say that the peel force of the Ceredas patch due to the applied air pressure is distributed over a larger circumference, and that this way the adhesion force is overestimated. Isolated testing of all adhesives could eliminate this uncertainty, but must require an equal fixation of the adhesives to the patch, which is difficult to realize.

The normal skin temperature of the frontal torso is  $32.5 (\pm 0.8)^\circ\text{C}$ , at an ambient temperature of  $22.4\text{ }^\circ\text{C} (\pm 1.7^\circ\text{C})$ . The temperature of the face can get up to  $33.7 \pm 0.8^\circ\text{C}$ <sup>15</sup>. We postulated that the patch would act as a thermal insulator on the skin. Therefore we used a higher temperature of  $36^\circ\text{C}$  during our tests. We did not test the actual temperature of the skin under the patch in vivo.

The results of the tests show a large range of failure time within the same tracheostoma patches, even in this standardised test setup. Factors that can contribute to this are the pressure on the patch during application and the time between application and testing. Although after placement, all patches were pressed to the artificial skin for 1 minute and a 5 minute waiting period was employed to ensure proper adhesion, it must be noted that the manufacturer of for example the Provox patches recommends a waiting period of 20 minutes before use. This factor can negatively influence the time in situ.

During coughing, for a short period of time, the intra-tracheal pressure rises to 4.9 to 6.5 kPa. This is 3 times in excess of the maximum that stoma patches can withstand under a constant pressure. Although application of a constant pressure to a stoma patch is likely to cause failure at a lower pressure than a short burst, it is not an ideal situation for a reliable tracheostoma patch.

For testing purposes these patches were cut circular in order to compare the adhesives independent of the patch shape. In everyday use, these patches might be able to withstand higher pressures in vivo due to their specific shape. An in vivo study with different patch shapes is now in progress.

## Conclusion

These results show that these commercially available adhesive patches perform comparable in the in vitro situation, with the exception of the Ceredas patch. These results also show that the Principality G601 adhesive performs comparable to the Atos Flexiderm and Blom-Singer Truseal or (slightly) better than the other adhesives, although not significant. Especially the consistency of the adhesion capacity advocates that it is worthwhile to test Principality G601 clinically.

## Acknowledgments

We would like to acknowledge E.D. de Jong, A.J. Wachtmeester, T. Oude Hengel, J.M. Gijzel, A.E. Schoeman and M. Schouten for their work on the testing equipment and artificial skin.

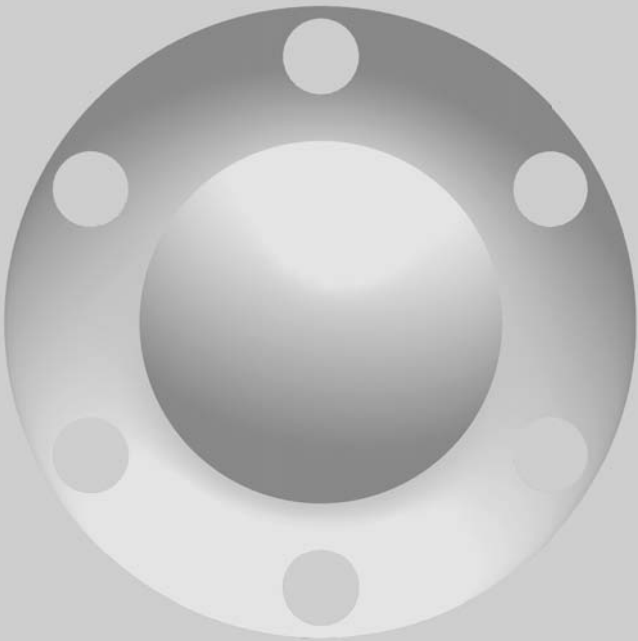




## References

1. Hilgers FJ, Ackerstaff AH, van As CJ, Balm AJ, Van den Brekel MW, Tan IB. Development and clinical assessment of a heat and moisture exchanger with a multi-magnet automatic tracheostoma valve (Provox FreeHands HME) for vocal and pulmonary rehabilitation after total laryngectomy. *Acta Otolaryngol* 2003;123:91-99.
2. Lorenz KJ, Groll K, Ackerstaff AH, Hilgers FJ, Maier H. Hands-free speech after surgical voice rehabilitation with a Provox((R)) voice prosthesis: experience with the Provox FreeHands HME tracheostoma valve((R)) system. *Eur Arch Otorhinolaryngol* 2007;264:151-157.
3. Geertsema AA, Boonstra CW, Schutte HK, Verkerke GJ. Design and test of a new tracheostoma valve based on inhalation. *Archives of Otolaryngology Head and Neck Surgery* 1999;125:622-626.
4. Geertsema AA, Schutte HK, Verkerke GJ. In vivo measurements of an improved tracheostoma valve based on inhalation. *Ann Otol Rhinol Laryngol* 2002;111:142-148.
5. Bien S, Okla S, van As-Brooks CJ, Ackerstaff AH. The effect of a Heat and Moisture Exchanger (Provox HME) on pulmonary protection after total laryngectomy: a randomized controlled study. *Eur Arch Otorhinolaryngol* 2010;267:429-435.
6. Op de Coul BM, Ackerstaff AH, van As-Brooks CJ, et al. Compliance, quality of life and quantitative voice quality aspects of hands-free speech. *Acta Otolaryngol* 2005;125:629-637.
7. ten Hallers EJ, Marres HA, Rakhorst G, et al. Difficulties in the fixation of prostheses for voice rehabilitation after laryngectomy. *Acta Otolaryngol* 2005;125:804-813.
8. Hilgers FJ, Dirven R, Wouters Y, Jacobi I, Marres HA, van den Brekel MW. A multicenter, prospective, clinical trial evaluating a novel adhesive baseplate (Provox StabiliBase) for peristomal attachment of postlaryngectomy pulmonary and voice rehabilitation devices. *Laryngoscope* 2012;122:2447-2453.
9. van Kalkeren TA, van der Houwen EB, Duits MA, et al. Worldwide, multicenter study of peristomal geometry and morphology in laryngectomees and its clinical effects. *Head Neck* 2011;33:1184-1190.
10. van der Houwen EB, van Kalkeren TA, Post WJ, Hilgers FJ, van der Laan BF, Verkerke GJ. Does the patch fit the stoma? A study on peristoma geometry and patch use in laryngectomized patients. *Clin Otolaryngol* 2011;36:235-241.
11. Hamade R, Hewlett N, Scanlon E. A quantitative and qualitative evaluation of an automatic occlusion device for tracheoesophageal speech: the Provox FreeHands HME. *Clin Linguist Phon* 2006;20:187-193.
12. Grolman W, Eerenstein SE, Tan FM, Tange RA, Schouwenburg PF. Aerodynamic and sound intensity measurements in tracheoesophageal voice. *ORL J Otorhinolaryngol Relat Spec* 2007;69:68-76.
13. Lavietes MH, Smeltzer SC, Cook SD, Modak RM, Smaldone GC. Airway dynamics, oesophageal pressure and cough. *Eur Respir J* 1998;11:156-161.
14. Bellamy KE. Development of a novel maxillofacial prosthetic material. 2004.
15. Tkápiová M, Hudák R, Živpák J, Sidun J. Thermographic Atlas of the Human Body. 15th International Conference on Intelligent Engineering Systems 2011:23-25.





# In Vivo Evaluation of the iPatch: A Novel Tracheostoma Patch.

T.A. van Kalkeren<sup>1</sup>, E.B. van der Houwen<sup>2</sup>, M.J.C. van den Berge<sup>1</sup>, G.J. Verkerke<sup>2,3</sup>,  
B.F.A.M. van der Laan<sup>1</sup>

Submitted

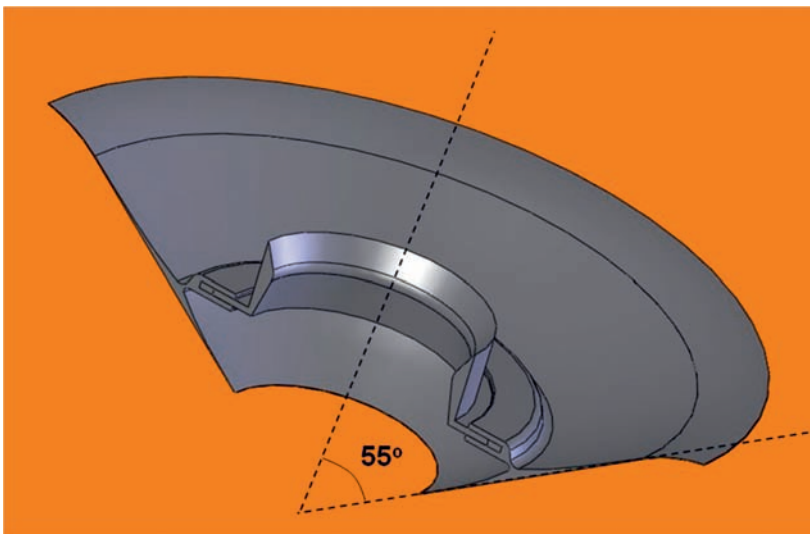
<sup>1</sup>Dept of Otorhinolaryngology/Head&Neck Surgery and <sup>2</sup>Dept of Biomedical Engineering,  
University of Groningen, University Medical Center Groningen, Hanzeplein 1, 9700 RB,  
Groningen, the Netherlands

<sup>3</sup>Faculty of Engineering Technology, University of Twente, the Netherlands.

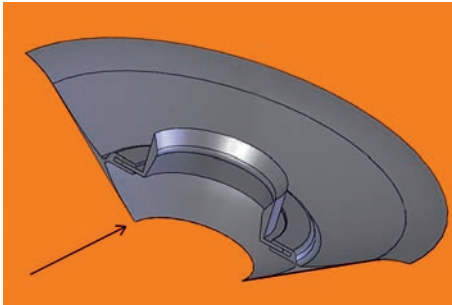
## Introduction

Patients lose their normal capability to speak after laryngectomy. During this procedure a tracheostoma is created ventrally in the neck to enable breathing. To facilitate rehabilitation of laryngectomy patients, shunt valves to restore speech and filters to re-establish most nasal functions are applied frequently <sup>1,2</sup>. Tracheostoma aids such as tracheostoma speech valves (TSVs) <sup>3,4</sup> that are attached to the tracheostoma allow hands-free speech. Filters and TSVs can be connected to an adhesive patch attached around the tracheostoma. However, only 25-30% <sup>2,5,6</sup> of all patients use these patches on a daily basis in combination with a TSV. Several reasons can be stated for the lack of use; most important are insufficient adhesion capacity, skin irritation and allergies <sup>1,7</sup>.

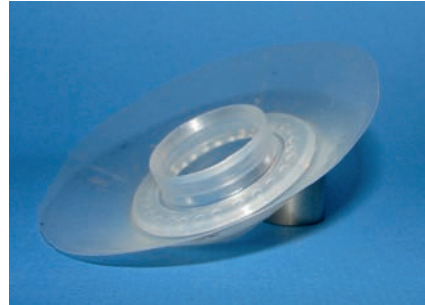
A recent published worldwide study of peristomal skin geometry revealed detailed data on size, shape and state of stomas <sup>8</sup> and showed a size mismatch between stoma and patches. These new insights have led to development of a tracheostoma patch with a novel shape and material properties. This newly developed tracheostoma patch adapts more natural to the shape of the tracheostoma. As half of the patients replaces its tracheostoma patch daily, the patch was designed to attain in situ for a minimum duration of 12 hours before detachment and to be very comfortable <sup>9</sup>. The present study is a feasibility study to test if the iPatch meets its design criteria.



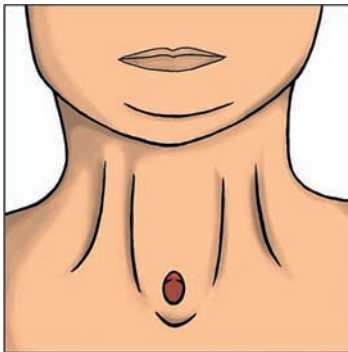
**Figure 1.** Opening angle of the silicon stoma patch (outer diameter 71 mm).



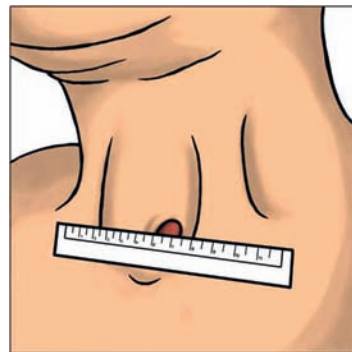
**Figure 2.** Sketch of a cross-section of the iPatch. The skirt (arrow) on the inside of the universal connector is meant to prevent peeling forces upon the free edge of the patch.



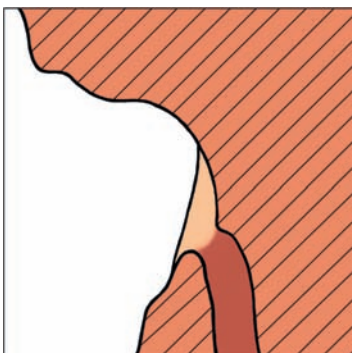
**Figure 3.** The silicone rubber based tracheostoma patch has a thin flexible conical base.



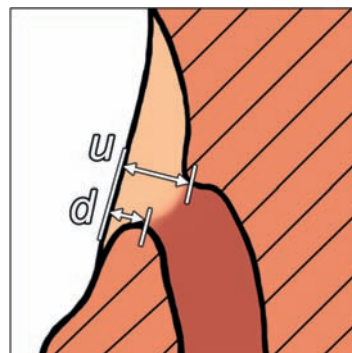
**Figure 4.** Frontal view of the tracheostoma.



**Figure 5.** A flat ruler is positioned over the sternocleidomastoid muscles, defining the upper border of the conical shape of the peristoma.



**Figure 6.** A model of a sagittal view of the tracheostoma.



**Figure 7.** The upper (u) and lower (d) border of the tracheostoma were measured.



## Materials and Methods

In this study, a total of 39 patients were included. Inclusion criteria were laryngectomized patients between 45 and 70 years old that have been using a trachea-esophageal shunt prosthesis for their phonation for at least six months. Excluded were patients with ulceration, infection or metastasis around or in the stoma or with severe respiratory problems. In general, patients in such bad health that cooperation with this study is too much of a burden were excluded. Written informed consent was given by the patients for data to be collected and used for future clinical research.

Patients made use of a new stoma patch, the iPatch, developed by the Department of BioMedical Engineering of the University Medical Center Groningen, The Netherlands. The new patch is characterised by a funnel-shape with an opening angle of 55 degrees (Figure 1). The diameter is 71 mm, this is smaller than the Provox Flexiderm, which has a diameter of 76 mm and broadens to 100 mm at the lateral sides at which it contains an extension. Worldwide studies on peristomal geometry<sup>8,10</sup> (this thesis Chapter 2 & 3) showed that most (if not all) tracheostoma patches which suffered from fast detachment did so at the inner border of the patch. A free floating inner edge was created on the inside of the universal connector to prevent forces upon the free edge of the patch (Figure 2). To achieve a soft, comfortable and non irritating patch, it was made from a thin sheet of silicone rubber (Figure 3). Its flexible design is in contrast to the commercially available Provox Stabilibase which is on the market since 2012. The Provox Stabilibase was designed to improve stability by using a firm baseplate with stabilizing bars to counteract the phonatory pressure during voicing<sup>11</sup>. All patches were prepared with the same glue as the worldwide commonly used Flexiderm®, Atos, Sweden tracheostoma patch.

At the beginning of the study, patients were asked to fill in a questionnaire regarding their stoma status, physical complaints related to the stoma and experience with previous stoma adhesives. Next, the stoma was photographed from frontal and both lateral perspectives and the stoma measures were systematically collected (Figure 4-7)<sup>8</sup>. Mean tracheostoma depth was calculated as  $(u+d)/2$  with  $u$  = the upper border and  $d$  = the lower border of the stoma.

Finally, patients were instructed by a short training in how to attach the stoma patch. Throughout the use of the stoma patch patients were asked to keep a journal with a study specific questionnaire about the use of the patch and, most importantly, to register the time in hours and date of applying and removing the patch. Patients were instructed to use the patch as long as it would stay attached to the peristomal skin. Together with the patch, 4 Atos Provox® HME HiFlow Cassettes were provided.

No co-intervention has been made and patients were allowed to use co-medication and diet as they wished. After the use of the patch, the journal was returned to the investigators.

The study was approved by the local medical ethical committee.

### *Statistical analysis*

Patch in situ times and stoma geometry were analyzed using SPSS statistics version 18.0. Normality of all parameters was checked visually using histograms and Q-Q plots and where needed the parameters were log<sup>10</sup>-transformed to achieve normality.

## **Results**

11 Patients did not supply sufficient data or did not return their tracheostoma diary booklet. As a result they were excluded from the study. The aim of the study was to design a patch that could stay in situ for more than 12 hours. In total 61% of patches in situ lifetime longer than 12 hours (Figure 8).

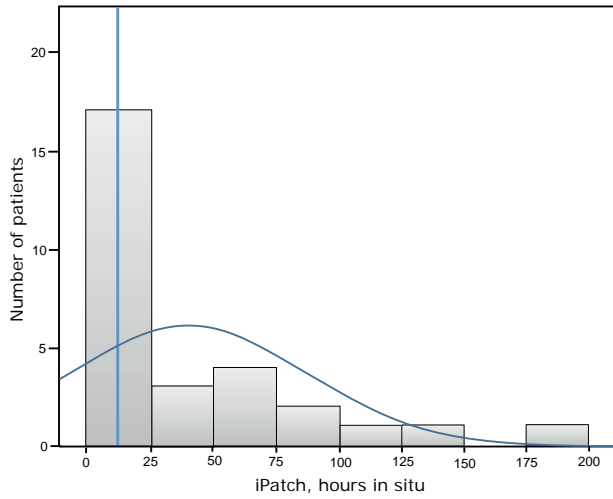
If only the patients who had a mean depth of the tracheostoma of more than 11 mm were taken in consideration (N = 8) the mean duration of the patch in situ was 48,6 hours (Std.Dev. = 0.48). This is in accordance with the results of Ackerstaff et al. in which half the patients replaced the adhesive daily, while in the remainder the plaster adhered to the skin optimally for 2 days or more <sup>9</sup>.

### ***Results of the questionnaire***

89% of the patients did not or experienced very little irritation of the skin when using the tracheostoma patch.







**Figure 8.** Histogram showing the duration of the patch in situ. The blue line shows the 12 hour in situ mark, which was the aim of the study. The curved line represents Gaussian fit to the histogram. The patch noticeably surpasses the aimed goal.



**Figure 9.** The thin silicon patch proved to be highly translucent.



**Figure 10.** The thin pliable patch is able to adapt to the peristomal skin shape during head movement, the more rigid connector can only do this to some extent.

## Discussion

For laryngectomy patients TSV's and HME's are important rehabilitating tools for increasing QoL and preventing complications like pneumonia. However, only 25-30% is using them. One of the important reasons for this is a size mismatch between stoma and patch. The iPatch is designed to have a better match for most laryngectomized patients. Therefore it has a funnel shape. Other important features are a skirt on the inside of the universal connector to distribute the load in a better way and the use of a thin silicone rubber sheet to prevent skin irritation. The results show that the iPatch performs within the design criteria, both in time of attachment as well as in comfort.

The silicone rubber patches were pretreated by a plasma treatment. Nonetheless, in some cases the attachment of the glue to the skin was still more powerful than the attachment of the glue to the silicone rubber patch. In addition, applying the glue to the very thin and pliable edges of the patch was a challenge in itself. This can also be seen in the right upper corner of the patch in Figure 8. Therefore, we feel that improvement of these features can result in a further improvement of this prototype.

The translucent and shiny appearance of the patch did cause some debate among patients (Figure 9). 10 Patients were very content, stating that the shiny surface was fresh and hygienic. 2 Patients did not like this feature as it draws attention to their disability.

The number of patients who experienced skin irritation was very low. This is in accordance to tests performed with the Provox Flexiderm patch, in which skin irritation resulting from the adhesive occurred in only 9% of the patients<sup>9</sup>. Patients who cannot wear a tracheostoma patch due to a very sensitive skin, as do most of the patients who underwent postoperative radiotherapy and have a deep stoma might be helped using this soft and pliable tracheostoma patch (Figure 10).

At last, it was clear that patients with a mean tracheostoma depth of 11 mm or more did benefit from the funnel shaped patch, although not significantly more ( $p=0.15$ ). Possibly, an advanced version of the prototype iPatch could be introduced on the market as the ideal patch especially for this patient category. It is not known how well the iPatch interacts with a hands-free TSV, for which further studies have to be performed.



## Conclusion

Lifetime of the iPatch did meet the requirement of 12 hours in 61% of the patients. The mean lifetime is in accordance to the Provox Flexiderm tracheostoma patch, which uses the same adhesive; it's flexible design or smaller patch diameter did not show a negative effect. The funnel shape integrates well to deep tracheostomas. The patch is comfortable, which is (partly) a result of it being made out of extremely thin flexible silicone rubber, reducing sheer stresses on the skin. In addition, the new silicone patch proved to induce little skin irritations. Further improvement is possible regarding the connection of the glue to the silicone rubber patch. Within the conceptual framework the patch has proven to be a viable design.

## Acknowledgements

We thank Principality Medical Ltd, Newport, Wales, for generously supplying the majority of the silicone rubber material. We also thank Atos Medical AG, Hörby, Sweden for their supply of patch connectors.

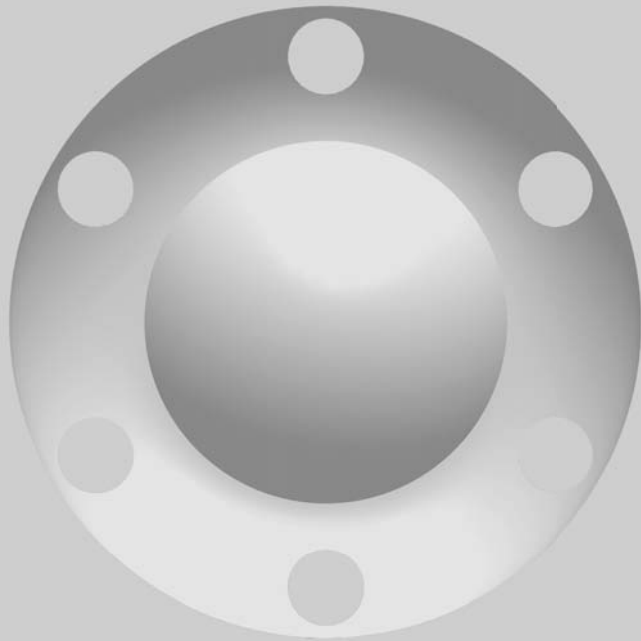
## Reference list

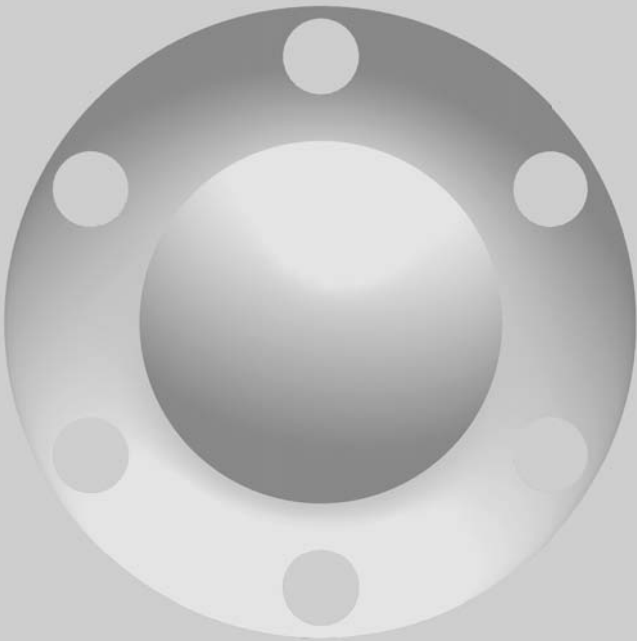
1. Hilgers FJ, Ackerstaff AH, van As CJ, Balm AJ, Van den Brekel MW, Tan IB. Development and clinical assessment of a heat and moisture exchanger with a multi-magnet automatic tracheostoma valve (Provox FreeHands HME) for vocal and pulmonary rehabilitation after total laryngectomy. *Acta Otolaryngol* 2003;123:91-99.
2. Lorenz KJ, Groll K, Ackerstaff AH, Hilgers FJ, Maier H. Hands-free speech after surgical voice rehabilitation with a Provox((R)) voice prosthesis: experience with the Provox FreeHands HME tracheostoma valve((R)) system. *Eur Arch Otorhinolaryngol* 2007;264:151-157.
3. Geertsema AA, Boonstra CW, Schutte HK, Verkerke GJ. Design and test of a new tracheostoma valve based on inhalation. *Archives of Otolaryngology Head and Neck Surgery* 1999;125:622-626.
4. Geertsema AA, Schutte HK, Verkerke GJ. In vivo measurements of an improved tracheostoma valve based on inhalation. *Ann Otol Rhinol Laryngol* 2002;111:142-148.
5. Bien S, Okla S, van As-Brooks CJ, Ackerstaff AH. The effect of a Heat and Moisture Exchanger (Provox HME) on pulmonary protection after total laryngectomy: a randomized controlled study. *Eur Arch Otorhinolaryngol* 2010;267:429-435.
6. Op de Coul BM, Ackerstaff AH, van As-Brooks CJ, et al. Compliance, quality of life and quantitative voice quality aspects of hands-free speech. *Acta Otolaryngol* 2005;125:629-637.
7. ten Hallers EJ, Marres HA, Rakhorst G, et al. Difficulties in the fixation of prostheses for voice rehabilitation after laryngectomy. *Acta Otolaryngol* 2005;125:804-813.
8. van Kalkeren TA, van der Houwen EB, Duits MA, et al. Worldwide, multicenter study of peristomal geometry and morphology in laryngectomees and its clinical effects. *Head Neck* 2011;33:1184-1190.
9. Ackerstaff AH, Hilgers FJ, Balm AJ, Tan IB. Long-term compliance of laryngectomized patients with a specialized pulmonary rehabilitation device: Provox Stomafilter. *Laryngoscope* 1998;108:257-260.
10. van der Houwen EB, van Kalkeren TA, Post WJ, Hilgers FJ, van der Laan BF, Verkerke GJ. Does the patch fit the stoma? A study on peristoma geometry and patch use in laryngectomized patients. *Clin Otolaryngol* 2011;36:235-241.
11. Hilgers FJ, Dirven R, Wouters Y, Jacobi I, Marres HA, van den Brekel MW. A multicenter, prospective, clinical trial evaluating a novel adhesive baseplate (Provox StabiliBase) for peristomal attachment of postlaryngectomy pulmonary and voice rehabilitation devices. *Laryngoscope* 2012;122:2447-2453.





# A new hands-free speech valve





# In Vitro Evaluation of the iValve: A Novel Hands-Free Speech Valve.

Eduard. B. van der Houwen\*<sup>1</sup> MSc, Tjouwke. A. van Kalker<sup>2</sup> M D,  
Johannes. G. M. Burgerhof<sup>3</sup> MSc, Bernard. F. A. M. van der Laan<sup>2</sup> MD PhD,  
Gijsbertus. J. Verkerke<sup>1,4</sup> MSc PhD.

Annals of Otology, Rhinology & Laryngology. 2011 Dec; Volume 120, Issue 12,  
Pages 814-819.

<sup>1</sup>Dept of Biomedical Engineering and <sup>2</sup>Dept of Otorhinolaryngology/Head&Neck Surgery,  
and <sup>3</sup>Dept of Epidemiology, University Medical Center Groningen, University of Groningen, A.  
Deusinglaan 1, 9713AV, Groningen, the Netherlands.

<sup>4</sup>Faculty of Engineering Technology, University of Twente, the Netherlands

This study was presented the 20<sup>th</sup> of January 2011, at the 3<sup>rd</sup> DutchBME Conference 2011 in  
Egmond aan Zee, The Netherlands.

This study was funded by grant 0903-40 from the Nuts-Ohra fund, a not-for-profit organization  
promoting applied medical research,. Authors van der Houwen, Verkerke, and van der Laan are  
inventors/applicants of the pending patent "Tracheostoma valve," EP 2 236 165 A1.

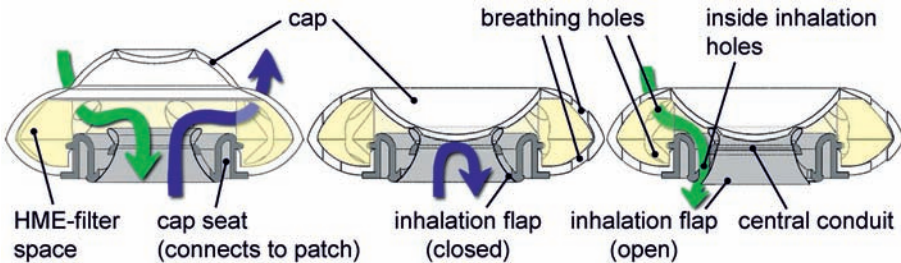


## Introduction

Tracheostoma valves for speech restoration are known to improve the overall quality of life in laryngectomy patients.<sup>1,2</sup> In particular, hands-free speech using automatic tracheostoma speech valves (ASVs) is very well received by patients.<sup>1,2</sup> These valves have been on the market for some time.<sup>3-5</sup> Most commonly used ASVs are the Atos Provox FreeHands adjustable tracheostoma valve (Atos Medical AG, Hörby, Sweden), the Blom-Singer ATSV standard and ATSV II adjustable tracheostoma valves (Helix Medical, Carpinteria, USA) and the Adeva Window (Adeva Medical, Lübeck, Germany). All commercially available ASVs close upon strong *exhalation* and open again when the pressure drops. This method wastes valuable air during closure, leaving less air for longer sentences without using additional breaths. During speech, pressure should be maintained to prevent the valve from opening again, making pausing between words impossible. The resulting sentences are often short, with frequent breaths of air in between, leaving patients feeling out of breath and quickly fatigued.



**Figure 1.** Atos Provox FreeHands HME automatic exhalation valve (with heat and moisture exchange (HME) filter) A) on patient and B) on patch next to C) iValve automatic inhalation valve (without HME).



**Figure 2.** iValve hands-free inhalation valve prototype (with space for the HME-filter in yellow) A) in open, breathing position, B) in closed, speaking position, and C) at inhalation (inhalation flap open) in closed, speaking position. Inhaled air indicated by green, exhaled air indicated by blue arrows.

A new ASV principle based upon *inhalation*<sup>6-8</sup> has already been demonstrated. This principle eliminated the problems associated with ASVs based upon the principle of closure upon *exhalation*. Major improvements of this mechanism compared to exhalation ASVs are the possibility of prolonged speech, the possibility of coughing without removing the valve, and the prevention of wasting exhaled air in closing the valve.<sup>7</sup> The newly developed iValve (Figure 1C, and 2) introduced in this paper is based upon this principle. The current 3-part design is targeted to decrease manufacturing costs as compared to the existing valves, possibly allowing use as a one-use-only disposable device.

This study investigates the feasibility of the iValve for clinical use by comparing its operational characteristics to physiological values. First, we checked if the closing flows and opening pressures of the iValve could be independently controlled within the physiological pressure and flow ranges that can be produced by laryngectomy patients. Second, we investigated whether the airflow resistance coefficient (ARC) at inhalation in both speaking and breathing modes is comparable to the healthy physiological situation and to that with two commercially available, and widely used, valves.

## Materials and methods

### *iValve.*

The iValve is composed of only 3 parts that are assembled to form a single unit. The device comprises a cap, a cap seat, and a foam-like heat and moisture exchange (HME) filter in between (Figure 2).

In order to start speech, the patient closes the iValve by strong inhalation (just exceeding normal breathing flows). In this speech position, the patient can speak (Figure 2B) almost naturally, pausing and whispering at will. The cap is the actual switching valve. The cap can buckle from the outward, breathing mode (Figure 2A), to the inward (Figure 2B), speaking mode, in which it effectively closes off the central breathing conduit, rerouting all exhaled air for speech. The valve will remain in the speech position, and inhalation is only possible via a different route through the inside inhalation holes (Figure 2C, green arrow), around the central breathing conduit of the cap. To be closed at *exhalation*, the inside holes are covered with a circumferential flap on the patient side of the cap seat, which closes off the holes



at *exhalation* when the circumferential flap is pressed against the inhalation holes by air pressure during speech.

The patient can switch the valve back into the breathing mode by strong exhalation, exceeding the phonation pressure (Figure 2A): the cap buckles outward, and air can freely flow through the central breathing conduit, the HME, and the breathing holes. All air - during speech only at inhalation, and during breathing at both inhalation and and exhalation - is drawn through the HME filter. Exhalation for breathing is possible in the speaking mode, but will not be "Voiceless"; for silent and higher-flow exhalation, the patient will have to exhale strongly and thus switch the valve back to the breathing mode.

The opening pressure and closing flow can be adjusted to suit the individual patient. The number of air holes is designed to determine the closing flow of the iValve. The pressure to open the iValve is designed to be varied by changing the cap thickness. At the time of this study, an HME-filter that was also suitable for the *in vivo* follow-up study was not yet available. Therefore, all opening and closing tests were performed without this filter. The absence of the HME-filter will not influence opening pressures, since the iValve is then closed and there is no airflow at all. It is however, likely to influence the closing flow. The HME was not considered essential to this stage of evaluation of the novel iValve prototype design.

For the opening pressure and closing flow measurements, 18 iValve caps with 6 different cap thicknesses (1.10, 1.17, 1.24, 1.36, 1.40 and 1.44 mm; 3 identical specimens per thickness) were molded from silicone rubber (Z001, Principality Medical Limited, Newport, UK). All caps were tested in conjunction with a single cap seat, molded from the same material.

For comparison of airflow resistance at inhalation, one Atos Cassette manual speech valve and one Atos FreeHands automatic speech valve (with the blue valve flap) served as references.

### ***Test set-up***

The valve's response characteristics were tested on a pneumatics simulator, a device that simulates the physiological pneumatics of respiration, speech and coughing (Figure 3). The device comprised a testing table with a standard Atos Provox connector to which all valves were attached for testing.

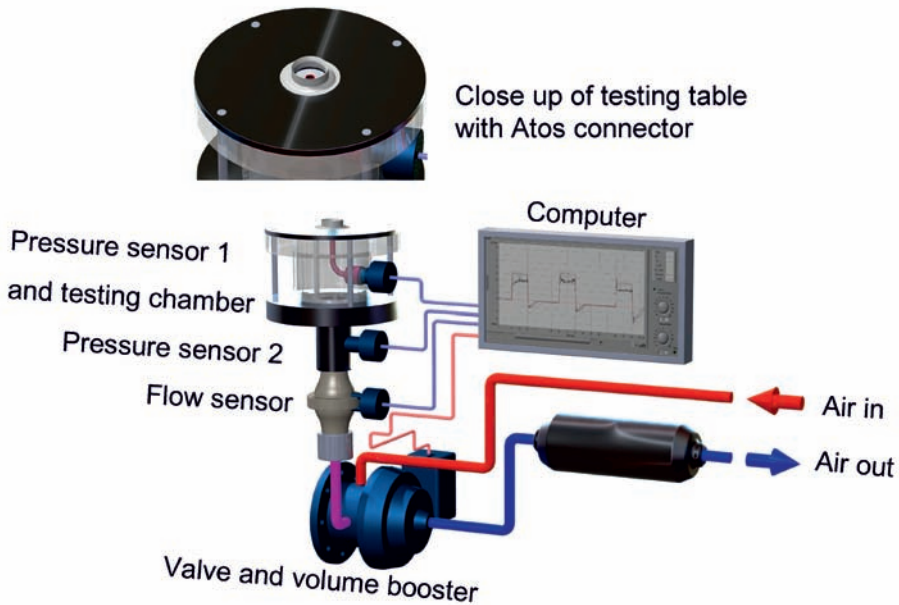


Figure 3. Pneumatics Simulator and close-up of Atos patch on top the testing table (top).

A computer-controlled valve (pressure regulator QB2TFEE002 with volume booster R0002-B, Proportion-Air, McCordsville, USA) controlled the pressure in the testing chamber under the testing table with the valve. For testing the valves under inhalation, the testing table with the valve attached was mounted upside down on the pressure chamber. The pressure in the testing chamber under the valve was monitored continuously with a pressure sensor (DSY002, Proportion-Air), and plotted against time. The flow through the testing table was monitored continuously by means of a Lilly-type wire gauze flow head (AD Instruments MLT300L, Oxford, UK) that was connected to a differential pressure transducer (Honeywell DC001NDC4, Freeport, USA) and plotted against time as well.

#### ***Investigation closing flow and opening pressure***

All iValves were submitted to a dynamic pressure pattern (rise time less than 0.15 seconds). For this, a block-shaped pressure pattern (1.5 second plateau) was generated, each time with increased pressure (0.1-kPa steps starting at 1 kPa) until the flow or pressure at which the valve switched was established.

Every cap (6 thicknesses x 3 identical specimens) was tested with 4, 6, 8 and 10 air holes, punched in the edge of the cap, and tested 3 times at both inhalation



(determining closing flow) and exhalation (determining opening pressure). Thus, 216 closing pressure values and 216 opening flow values were collected in total.

### ***Investigation and comparing of air resistance***

The ARC used throughout this paper is defined as the pressure difference divided by the squared flow as suggested by Verkerke et al.<sup>9</sup> This definition of ARC yields a coefficient independent of airflow.<sup>9</sup>

For this experiment, 6 iValves with only 1 cap thickness (1.24 mm, representing the average thickness) were used. The iValve's ARC was measured in both breathing (open) and speaking (closed) modes.

The ARCs at inhalation of the iValve, Atos Cassette and Atos FreeHands were tested using the same pneumatics simulator setup. The airflow through the valves was slowly increased from 0.6 to 3.0 L/s, and the air pressure within the valve was registered at 0.3-L/s intervals. The ARC was calculated from these data as the pressure difference (between the atmospheric and the testing chamber pressure) divided by the squared flow through the valve. For fair comparison, the iValve was equipped with an HME-filter in the designated cap cavity, cut from Atos HME filter foam. Although this filter made it possible to test the ARC, it was not yet suitable for safe *in vivo* testing.

### ***Statistics***

The relation between flows, pressures, cap thickness, and number of holes was investigated using a linear mixed-effects model generated with a restricted maximum likelihood approach. In all tests, an alpha level of 0.05 was used to indicate significance.

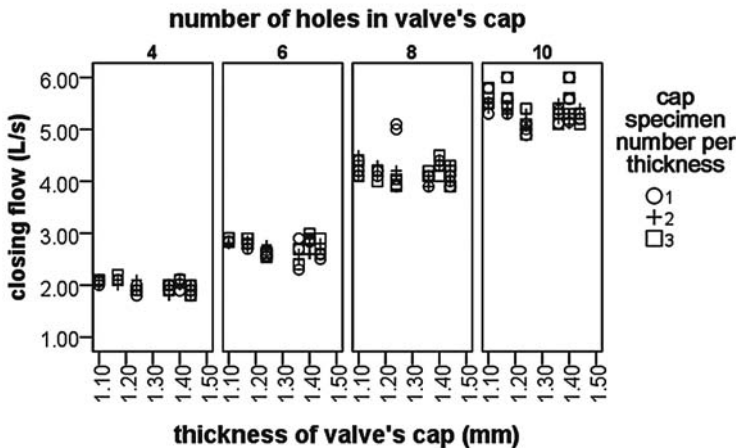
## **Results**

### ***Closing flow and opening pressure of iValve.***

Figure 4 shows the closing flow (from breathing to speaking mode) as a function of the thickness of the valve's cap (within a single panel) and as a function of the number of holes (between panels). When air holes are added, a clear increase in airflow can be observed, whereas the airflow seems unaffected by the valve cap thickness. The statistical mixed effect analysis confirmed that the number of holes has a significant ( $\alpha=0.05$ ) linear influence on the closing flow ( $p < 0.001$ ), whereas

the closing flow is not significantly influenced by cap thickness ( $p = 0.056$ ). Any 2 added holes increased the closing flow by 1.16 L/s. The closing flow range is 1.8 to 6.0 L/s.

Figure 5 shows the opening pressure (from speaking to breathing mode) as a function of the thickness of the valve's cap (within a single panel) and as a function of the number of holes (between panels). At an increased cap thickness, a clear increase in opening pressure can be observed. The number of air holes seemed to have little effect on the opening pressure. The mixed effect analysis confirmed this. Opening pressure significantly (significance level  $\alpha=0.05$ ) and linearly depends on cap thickness ( $p < 0.001$ ), and not on the number of holes ( $p = 0.64$ ). The opening pressure range is between 2.9 and 6.0 kPa.



**Figure 4.** Airflow (y-axis) at closing in 18 iValve specimens as function of cap thickness (x-axis) and number of air holes in the cap (consecutive panels). Three identical iValve cap specimens per thickness were each tested 3 consecutive times.



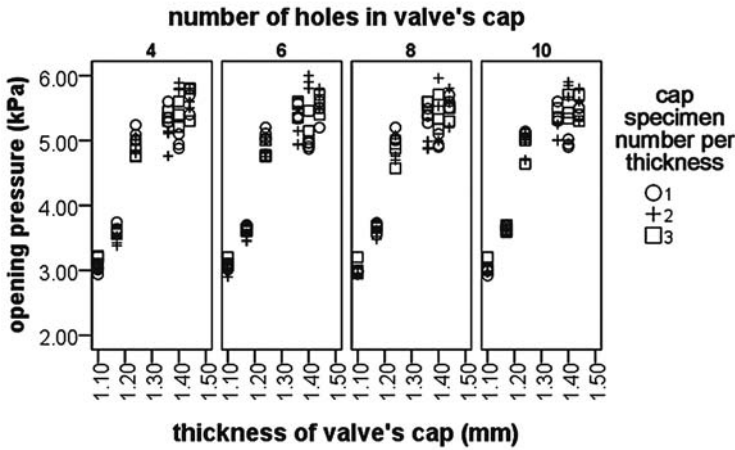


Figure 5. Air pressure at opening (y-axis) in 18 iValve specimens as a function of cap thickness (x-axis) and number of air holes in the cap (consecutive panels). Three identical iValve cap specimens per thickness were each tested 3 consecutive times.

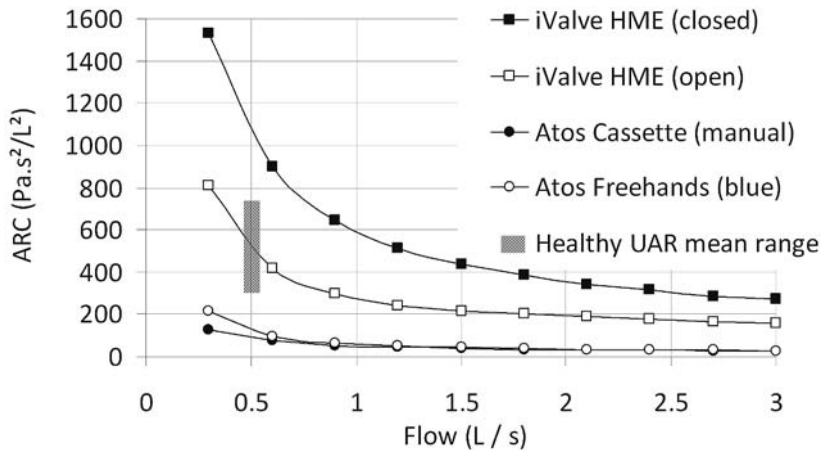


Figure 6. Airflow resistance coefficient (ARC; Pa · s<sup>2</sup>/L<sup>2</sup>) at inhalation versus flow (in L/s) for iValve (both open and closed), Atos FreeHands, and Atos Cassette. Natural upper airway resistance mean range is 0.5 L/s.<sup>10</sup>

**Airflow Resistance Coefficient**

Figure 6 shows a comparison of ARCs for different valves (6 iValves, 1 Atos Cassette, and 1 FreeHands) at inhalation, and the physiological upper airway resistance (UAR) at 0.5 L/s.<sup>10</sup> The iValve’s ARC graph (Figure 6) in the closed (speaking) mode shows a rapidly declining graph with mean values (±SD) ranging 1533 ± 474 to 270 ± 22, and decreasing with flow.

The iValve's ARC in the open (breathing) mode shows a much flatter graph, with values ranging from  $811 \pm 63$  to  $159 \pm 17 \text{ Pa} \cdot \text{s}^2/\text{L}^2$  and slightly decreasing with flow. The ARCs of the Atos Cassette and FreeHands are almost constant and identical. The iValve's ARC in the breathing mode is within the physiological UAR range; in the speaking mode, the ARC is above the UAR and is considerably higher than the ARCs of the Atos valves.

## Discussion

The opening pressures and closing flows of the iValve are independently controllable between 2.9 and 6 kPa and 1.8 and 6.0 L/s, respectively. The iValve's ARC is higher than those of the Atos valves, but around 0.5 L/s (quiet breathing<sup>10</sup>), it is just within the upper and lower ranges of the healthy physiological UAR coefficients found in the literature<sup>10</sup>. Decreasing the ARC of the iValve in the speaking mode will be one of the targets for the next version in ongoing development.

### **Closing flow**

The iValve's closing flow appears to linearly increase with the number of air holes, and appears to be independent on the valve's thickness (Figure 4). The closing flows of the iValve should be at least above those used in moderately intensive breathing (moderate exercise or daily activities) and below the laryngectomy patient's maximum. Quiet breathing, in laryngectomy patients and normal subjects (alike), is 0.1 L/s.<sup>11</sup> The peak inspiratory flow is 6.0 L/s<sup>12</sup> for healthy male subjects, and 2.5 L/s for asthma patients.<sup>13</sup> Geertsema et al<sup>8</sup> described an operating range of 1.7 to 3.8 L/s of closing flow in *in vivo* tests of their prototype. These physiologically attainable flows fall perfectly within the range of the iValve.

The closing flow measurements have been performed without HME filter. Arguably, the HME filter will influence (decrease) the closing flow of the iValve. Once the overall ARC has been decreased and HME filter is available, the final prototype will need readjusting to the patients' range of comfortable control flows. Since the relationship between the geometry and the control characteristics are now known, this is completely feasible.





### **Opening pressure**

The iValve's opening pressure appears to linearly increase with cap thickness, yet it appears to be independent of the number of air holes (Figure 5). The pressure's independence of air holes is not surprising, since at closure there is no flow and thus no influence of the air holes. The opening pressure of the iValve should be just higher than the pressures required for intelligible speech in laryngectomees. Geertsema et al<sup>8</sup> described an operating range of 0.8 to 7.2 kPa for the opening pressure in *in vivo* tests of their prototype. Roxburgh and Perry<sup>14</sup> found a range of 1.52 to 7.85 kPa for speech at normal loudness using the Blom-Singer ATV. Hamadé et al<sup>15</sup> found a range of 1.96 to 3.92 kPa with manual occlusion. Grolman et al<sup>16</sup> found a mean pressure of 3.2 kPa at manual occlusion during normal speech, and 6.6 kPa during loud speech. The physiologically attainable opening pressures also fall perfectly within the range of the iValve. The opening pressure measurements have been performed without HME filter. However, no influence on the opening pressure is expected, since the HME filter is positioned past the closed cap.

### **Airflow Resistance Coefficient**

The iValve's ARC decreases with increasing flow, and is not a single ARC. This finding is in concordance with definition of ARC of Verkerke et al<sup>9</sup> only, if we assume the circumferential flap valve progressively opens at higher flows.

The iValve's ARC in the breathing mode is comparable to that of the healthy physiological system. The ARCs of the Atos Cassette and the Atos FreeHands are almost identical and are considerably lower than that of the iValve.

Although an ARC comparable to the normal physiological situation will benefit the pulmonary system on the long-term,<sup>17</sup> patients prefer a much lower ARC. The mean nasal airway (nasal passage, pharynx and larynx) resistance at inhalation ranges from 304 to 742 Pa · s<sup>2</sup>/L<sup>2</sup> in normal healthy subjects.<sup>10</sup>

The iValve's ARC is overall considerably higher with the iValve in the closed (speaking) mode than in the open (breathing) mode, because in open position the central conduit is open to airflow as well.

Whether a high ARC during inhalation at speech is considered uncomfortable by the patient is unknown and can only be investigated in an *in vivo* study. Values in the healthy UAR lower range are the aim for our next prototype.

### **Clinical implications**

Because all patients are different, the iValve's required opening pressure (which also defines the maximum automatic speech loudness) can be selected by choosing an iValve version from a limited range of products. The iValve's closing flow can be adjusted in each iValve version by adjusting the number of open air holes in the cap.

The ARC of the iValve in the breathing mode already lies within the natural and healthy UAR range, but is higher than the ARCs of both Atos valves. The ARC at inhalation in the speaking mode is above the UAR and an *in vivo* study will have to show whether this is acceptable or will have to be decreased. Too high an ARC can be uncomfortable to the patient, but too low an ARC might decrease pulmonary function in the long term.<sup>17</sup>

## **Conclusions**

The iValve works as designed. It opens and closes at the appropriate physiological pressure and flow values. The opening and closing values can be independently controlled, so individual adjustment of the iValve is feasible and simple to implement. The closing flow in this prototype is adjusted by varying the number of holes in the cap, and the opening pressure can be selected from a limited range of (e.g. 3 to 5) versions.

The airflow resistance of the iValve at low flows and with an HME-filter present is higher than that of commercially available valves, but is within physiological values (at 0.5 l/s and higher flows). Only in the speaking mode, the airflow resistance will have to be decreased to be comparable to that of commercially available valves. This study shows that the iValve prototype is ready for evaluation in a clinical study. The iValve's design also shows that using skin-soft materials for the construction of this type of medical device is very feasible and can dramatically decrease the number of assembly parts and consequently potentially decrease manufacturing costs, opening the way to possible disposable solutions, and reaching patients in developing countries. The iValve promises to be a viable asset to the existing range of ASVs, with the added benefit of improved intuitive control and greater voice dynamics by the patient. The *in vivo* tests will show how these characteristics are perceived by patients.



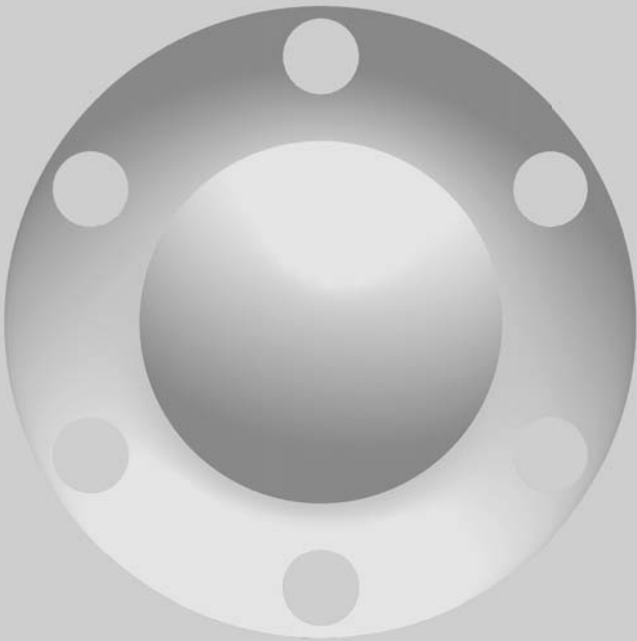
### **Acknowledgements**

We thank Dr. Y.J. Gu and Prof. G. Rakhorst for their valuable comments on this report. We thank R. Eleveld, L. Fledderus, B. Giesberts, A.-K. Klockow, N. Krop, S. Panahkhahi, C. Roossien, W. Sikkema, S. Sloot and M. Timmer for their contributions in developing, and H. Thole for his work on prototyping the iValve. We also thank L.H. Kuiper, H. Pragt, W.A.M.E. Schrijver and C. Roossien for their *in vitro* testing of the design and A.J. Wachtmeester and E.D. de Jong for their development of the Pneumatics Simulator device. We also thank Principality Medical Ltd, Newport, Wales, for generously supplying the majority of the silicone rubber material.

## Reference list

1. Lorenz KJ, Groll K, Ackerstaff AH, Hilgers FJ, Maier H. Hands-free speech after surgical voice rehabilitation with a Provox((R)) voice prosthesis: experience with the Provox FreeHands HME tracheostoma valve((R)) system. *Eur Arch Otorhinolaryngol.* 2007;264:151-157.
2. Op de Coul BM, Ackerstaff AH, van As-Brooks CJ et al. Compliance, quality of life and quantitative voice quality aspects of hands-free speech. *Acta Otolaryngol.* 2005;125:629-637.
3. Hilgers FJ, Ackerstaff AH, Van As CJ, Balm AJ, Van den Brekel MW, Tan IB. Development and clinical assessment of a heat and moisture exchanger with a multi-magnet automatic tracheostoma valve (Provox FreeHands HME) for vocal and pulmonary rehabilitation after total laryngectomy. *Acta Otolaryngol.* 2003;123:91-99.
4. ten Hallers EJ, Marres HA, Rakhorst G et al. Difficulties in the fixation of prostheses for voice rehabilitation after laryngectomy. *Acta Otolaryngol.* 2005;125:804-813.
5. van den Hoogen FJ, Meeuwis C, Oudes MJ, Janssen P, Manni JJ. The Blom-Singer tracheostoma valve as a valuable addition in the rehabilitation of the laryngectomized patient. *Eur Arch Otorhinolaryngol.* 1996;253:126-129.
6. Geertsema AA, de Vries MP, Schutte HK, Lubbers J, Verkerke GJ. In vitro measurements of aerodynamic characteristics of an improved tracheostoma valve for laryngectomees. *Eur Arch Otorhinolaryngol.* 1998;255:244-249.
7. Geertsema AA, Schutte HK, Verkerke GJ. In vivo measurements of an improved tracheostoma valve based on inhalation. *Ann Otol Rhinol Laryngol.* 2002;111:142-148.
8. Geertsema AA, Boonstra CW, Schutte HK, Verkerke GJ. Design and test of a new tracheostoma valve based on inhalation. *Archives of Otolaryngology Head and Neck Surgery.* 1999;125:622-626.
9. Verkerke GJ, Geertsema AA, Schutte HK. Airflow resistance of airflow-regulating devices described by independent coefficients. *Ann Otol Rhinol Laryngol.* 2001;110:639-645.
10. Verkerke GJ, Geertsema AA, Schutte HK. Airflow resistance of heat and moisture exchange filters with and without a tracheostoma valve. *Annals of Otolaryngology and Laryngology.* 2002;111:333-337.
11. Liu H, Wan M, Wang S, Niu H. Aerodynamic characteristics of laryngectomees breathing quietly and speaking with the electrolarynx. *J Voice.* 2004;18:567-577.
12. Depledge MH. Peak inspiratory flow: measurement using a modified mini Wright peak flow meter. *Thorax.* 1985;40:205-206.
13. Brown PH, Ning AC, Greening AP, McLean A, Crompton GK. Peak inspiratory flow through Turbuhaler in acute asthma. *Eur Respir J.* 1995;8:1940-1941.
14. Roxburgh J, Perry A. Use of a "hands-free" tracheostoma valve in patients with laryngectomy and tracheoesophageal puncture. *Ann Otol Rhinol Laryngol.* 2004;113:565-570.
15. Hamade R, Hewlett N, Scanlon E. A quantitative and qualitative evaluation of an automatic occlusion device for tracheoesophageal speech: the Provox FreeHands HME. *Clin Linguist Phon.* 2006;20:187-193.
16. Grolman W, Eerenstein SE, Tan FM, Tange RA, Schouwenburg PF. Aerodynamic and Sound Intensity Measurements in Tracheoesophageal Voice. *ORL J Otorhinolaryngol Relat Spec.* 2006;69:68-76.
17. Drake-Lee A. The physiology of the nose and paranasal sinuses. In: Gleeson M, ed. *Basic sciences; Scott-Brown's otolaryngology.* Oxford: Butterworth-Heinemann; 1997:1-21.





# In Vivo Test of a New Hands-Free Tracheostoma Inhalation Valve, a Randomised Crossover Study.

Tjouwke A. van Kalkeren, MD,<sup>1</sup> Eduard B. van der Houwen, MSc<sup>2</sup>,  
Willemijne A.M.E. Schrijver, BSc,<sup>1,2</sup> Gijsbertus J. Verkerke, PhD,<sup>2,3</sup>  
Bernard F.A.M. van der Laan, MD, PhD,<sup>1</sup>

Clinical Otolaryngology, 2013 Oct; Volume 38, Issue 5, Pages 420-424.

<sup>1</sup>Dept of Otorhinolaryngology/Head&Neck Surgery, University Medical Center Groningen, University of Groningen, Hanzeplein 1, 9700 RB, Groningen, the Netherlands.

<sup>2</sup>Dept of Biomedical Engineering, University Medical Center Groningen, University of Groningen, Hanzeplein 1, 9700 RB, Groningen, the Netherlands.

<sup>3</sup>Faculty of Engineering Technology, University of Twente, Postbus 217, 7500 AE Enschede, the Netherlands.

## Introduction

Tracheoesophageal speech is currently the most widely used technique for voice rehabilitation after total laryngectomy<sup>1,2</sup>. By this technique, an artificial fistula is created in the wall between the trachea and esophagus. A one-way valve prosthesis is placed in this artificial fistula, permitting air from the lungs to pass into the esophagus. To make use of the shunt valve the stoma requires closure with a finger or thumb. However, this is deemed unhygienic and some people cannot securely close the stoma by this means. Furthermore, it draws attention to the laryngectomy status and conversation is hampered if both hands are occupied.

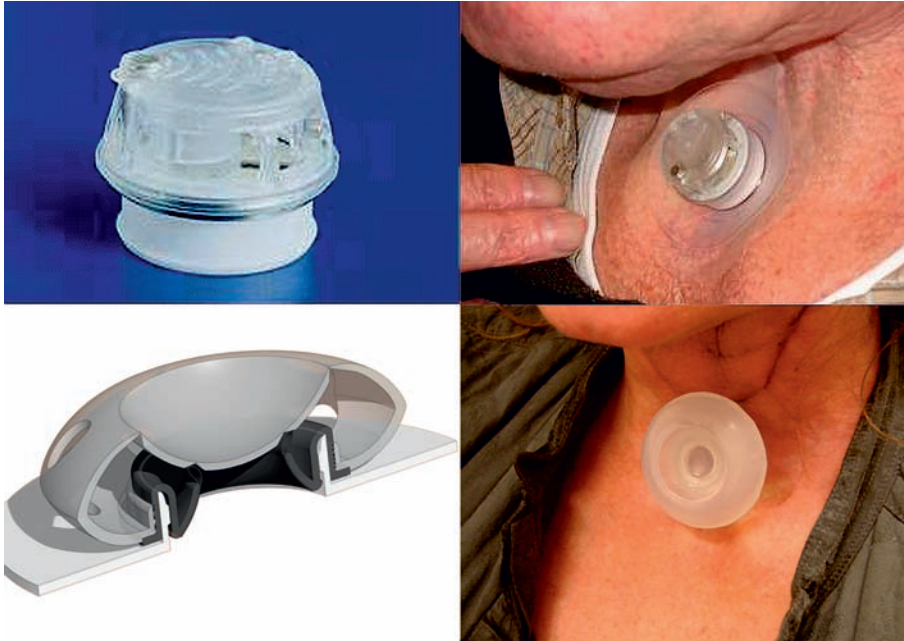
Hands-free tracheoesophageal speech adds to a more natural way of speaking after total laryngectomy<sup>1</sup>. To realize hands-free speaking, several tracheostomal valves have been designed in the past, which are based on the mechanism of closure at exhalation<sup>3-5</sup>. An example of a commonly used exhalation device is the Atos-Provox® FreeHands adjustable tracheostoma valve (Figure 1). This valve is closed by fast exhalation. With every inhalation the valve opens again, therefore continuation of speech after inhaling requires repeating closure of the valve by fast exhalation.

Therefore, this concept has its disadvantages. The most important disadvantage is that exhaled breathing air is spent by closing the tracheostomal valve, leaving less air available for phonation. Another disadvantage is that the next inhalation opens the valve again, thus constant phonation is not possible.

To challenge these problems, Geertsema *et al.* designed a new mechanism based on the principal of inhalation<sup>6,7</sup>. According to the author, major improvements are the possibility of continuous speech, coughing and that no exhaled air is spent to close the valve. To incorporate this mechanism, a new tracheostoma valve, called the iValve, has been developed (Figure 1). The new prototype valve closes by means of inhalation.

The iValve opens and stay open at strong positive air pressure (fast exhalation) and closes permanently at strong negative air pressure, at high flow (fast inhalation). This feature enables the patient to switch the valve harmoniously between the "speaking" and "breathing" setting.

Furthermore, the iValve incorporates a second valve, which enables the patient to inhale even when the valve is in the closed "speaking" setting, enabling continuous speech.



**Figure 1.** The Atos-Provox® FreeHands HME exhalation tracheostoma valve with a HME-filter (top, left) and a close-up of a patient wearing this valve, connected to a peristomal patch (an adhesive flange that is attached to the skin around the stoma on which a speech valve can be attached) (top, right). A cross-sectional view of the inhalation valve in closed position (bottom, left) and attached to the stoma using an adhesive patch (bottom, right).

Technical specifications and more in depth clarification of the in vitro testing of the iValve can be found in: *"In Vitro Evaluation of the iValve: A Novel Hands-Free Speech Valve"*; by van der Houwen et al.<sup>8</sup>

### ***Aims of the study***

The aim of the study was to compare speech using the iValve prototype to speech using the commercially available Atos Provox® FreeHands HME speech valve (referred to from here simply as the FreeHands device). The hypothesis was that it would be possible to speak longer as well as louder using the new iValve as compared to the FreeHands, at equal or lower intra-tracheal pressure.





## Materials and Methods

### *Ethical considerations*

This study was designed as a prospective evaluation of laryngectomy patients who were followed-up at the ENT Department of the University Medical Center Groningen. The Institutional Ethics Committee approved the study design and experimental protocols. All patients gave written informed consent for their participation.

### *Patients*

This was a monocenter, randomized clinical case series, performed in a tertiary referral head & neck oncology center in the Netherlands. Participants were all adults aged between 52 to 83 (mean 66) years which have undergone laryngectomy for at least 1 year prior. The number of laryngectomy patients in our clinic is over 134. Only patients who could speak with both the Freehands and the iValve were included in the study. Exclusion criteria were either low lung capacity, for which speech valve operation was deemed too difficult, or patients with irritated or irregular stoma's so that the valve could not be attached to the stoma. The study took place at the University Medical Center Groningen between April and December 2011.

The main outcome was to evaluate maximum phonation time of the new inhalation hands-free speech valve as compared to the Freehands speech valve. A sample size of 12 produces a 95% confidence interval equal to the standardised mean difference plus or minus 0,566. Taking a drop-out rate of 10% into account, 14 patients were included in this study. Secondary objective was measurement of the maximum loudness of speech and the subjective opinion of the patients regarding the iValve.

Before the study started, prior testing of the iValve was done to test if our design of the iValve would actually work. Four patients successfully participated in this test. Next, 14 patients were randomly assigned following simple randomization procedures (computerized random numbers) to 1 of 2 treatment groups which either used the iValve preceding the Freehands valve or vice versa. The outline of the study is expressed in Figure 2.

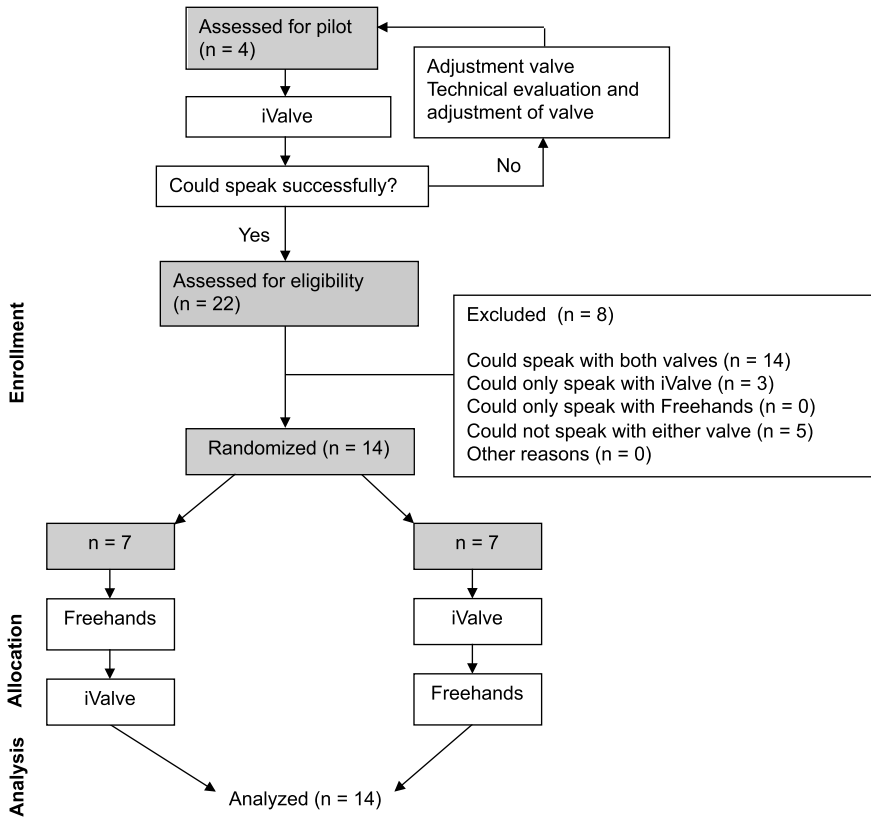


Figure 2. The flow diagram of the study. No loss to follow up was reported.

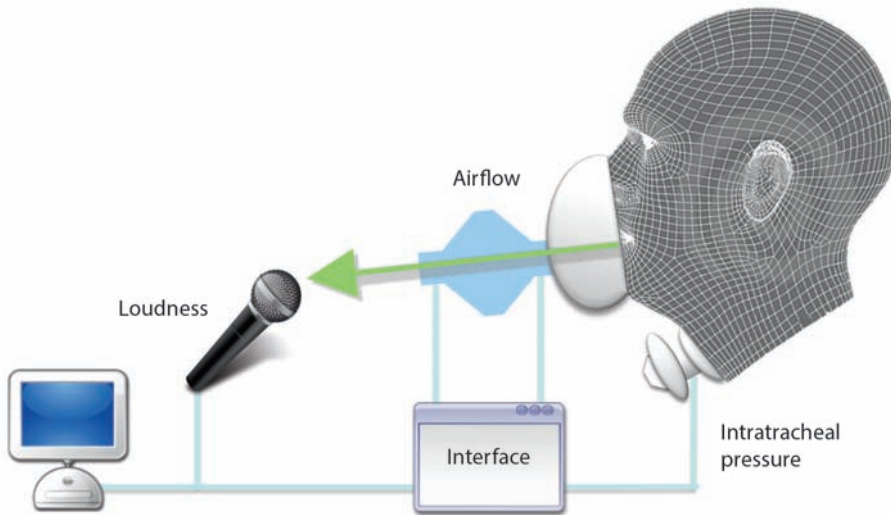
### Voice and speech assessment

During the study the following parameters were measured:

- Loudness and dynamic range in dB: The patient phonated a sustained vowel /a/ and sentences at three levels of phonation: as soft as possible, at comfortable loudness, and as loud as possible. After that, the patient had to read a 18 Dutch words and 5 sentences (containing 120 words in total), also at three levels of phonation. The sound was recorded, measured and visually plotted in a phonetogram.
- Maximum phonation time in seconds: The patient phonated a sustained vowel /a/, /e/ and /u/ at comfortable pitch and loudness after maximum inhalation. Time was measured using a stopwatch. Measurements were repeated three times for statistical analysis (median out of three calculated).



- Intra-tracheal pressure in kPa and flow in L/s: The patient phonated a sustained /a/ and sentences at two levels of phonation: as soft and loud as possible. After this, the patients were instructed to speak a Dutch sentence (“Ik heb zin in een kopje koffie”, Dutch for “I fancy a cup of coffee”), also at the two levels of phonation. The intratracheal pressure and flow was measured in the test setup as stated in Figure 3. Repeated three times for statistical analysis (median out of three calculated).



**Figure 3.** The test setup used to measure the flow, intra-tracheal pressure and loudness of voice during phonation. The test setup was custom made.

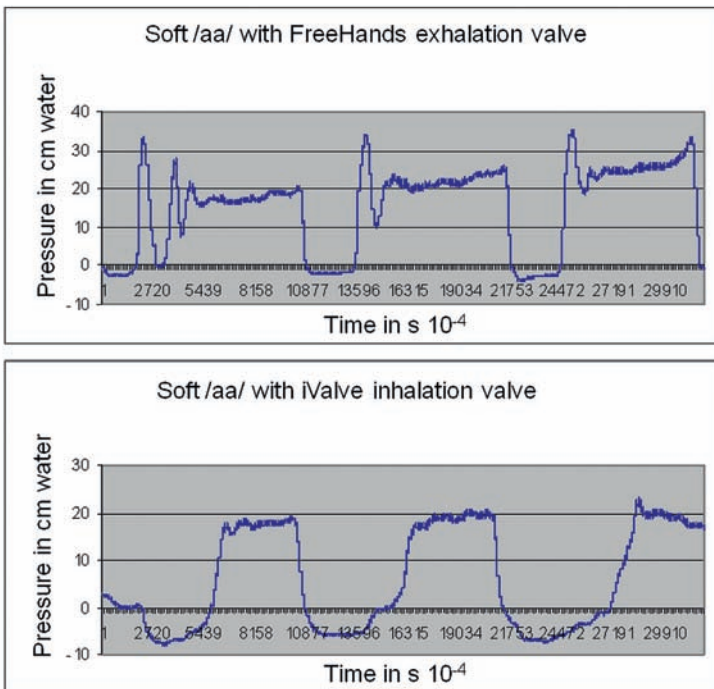
### **Structured Questionnaire**

Patients were asked to fill in a questionnaire. Some of the questions were; “Do you think closing of the stoma with a finger or thumb is annoying?”, “Would you prefer to use a hands-free valve if possible?”, “If you are able to use an automatic speech valve, do you believe that hands-free speech makes life easier?” and “What can or must be improved to the iValve to make it better?”

### Statistical analysis

SPSS version 16.0 was used. Statistical analysis was mainly based on comparison of two groups. Normality of all parameters was checked visually using histograms and Q-Q plots and where needed the parameters were  $\log^{10}$ -transformed to achieve normality. In case of normality, the paired sample T-tests were used. In case of non-normality, parameters with two-way classifications were tested using a Mann-Whitney non-parametric rank test. A two-tailed p-value of  $<0.05$  was taken to indicate statistical significance.

## Results



**Figure 4.** Intra-tracheal pressure during speech using a FreeHands exhalation (top) and an iValve inhalation valve (bottom). A clear peak pressure was measured during closure of the FreeHands, exerting stress between the stoma and stoma-connector.

### Loudness of speech and whispering

There was no significant difference found between either a loud sentence (FreeHands mean=88.1dB, sd=9.9, iValve mean=84.8dB, sd=12.3, p value of



difference between means=0.068), a soft sentence\* (FreeHands mean=69.9dB, sd=11.7, iValve mean=67.3dB, sd=12.4, p value of difference between means=0.394) and the dynamic range (FreeHands mean=18.1dB, sd=8.5, iValve mean=17.5dB, sd=9.6, p value of difference between means=0.744). Subjectively, 44% experienced a softer voice using the exhalation valve, 44% a louder voice and 11% could not point out a difference. Both results are indicating that there are no differences between the valves.

### ***Phonation time***

Phonation time in seconds showed no significant differences during the vowel /a/\* (FreeHands mean=8.1, sd=6.3, iValve mean=6.7, sd=4.2, p value of difference between means=0.713), /e/ (FreeHands mean=7.0, sd=5.8, iValve mean=6.4, sd=4.4, p value of difference between means=0.844) or /u/\* (FreeHands mean=7.4, sd=6.6, iValve mean=6.2, sd=4.3, p value of difference between means=0.836), indicating that there are no differences between the valves.

### ***Intra-tracheal pressure***

There's no significant difference in intra-tracheal pressure in cm H<sub>2</sub>O found when expressing a loud vowel /a/ (FreeHands mean=32.5, sd=17.0, iValve mean=31.0, sd=15.5, p value of difference between means=0.708), soft /a/ (FreeHands mean=18.0, sd=9.0, iValve mean=14, sd=0.8, p value of difference between means=0.158), loud sentence\* (FreeHands mean=37.0, sd=20.5, iValve mean=29.5, sd=11.0, p value of difference between means=0.168), soft sentence\* (FreeHands mean=20.5, sd=10.0, iValve mean=14.5, sd=5.5, p value of difference between means=0.089), indicating that there are no differences between the valves.

However the Freehands exerts a pressure peak when closing the valve at initiation of speech, Figure 4. The pressure peak was consistent in all but one patients (n=11) using the Freehand exhalation valves. The average pressure peak was 35,3 cm H<sub>2</sub>O (sd=9.7) in a loud vowel /a/ and 32,3 cm H<sub>2</sub>O (sd=14.2) in a soft vowel /a/. No consistent pressure peak was noticed in the iValve.

### ***Results of the questionnaire***

64% of the patients believe that closing the stoma with a finger or thumb is not annoying. However, 86% believe that hands-free speech makes life easier. All patients would like to use an automatic speech valve. 57% of the patients believe the iValve is more easy to use than the Freehands. However, 81% is of the opinion

that inhalation through the iValve in its closed position is too difficult.

\*not normally distributed.

## Discussion

### ***Synopsis of key/new findings***

The new iValve proved to be comparable in overall performance to the Freehands exhalation valve. As well the maximum phonation time, as the maximum loudness were on par on all parameters. The initial hypothesis of longer phonation and advanced loudness was therefore not met. However an added benefit of the iValve proved to be the ability to whisper, which was not possible using the current exhalation valves.

### ***Air resistance***

The patients' preference regarding a specific type of valve could be caused by the supplied air resistance of the speech valve. The aerodynamic properties of the iValve were not adapted to the patients' needs during this study. The final results could be optimized if the speech valves would be individually tailored to the patients.

A difference between the valves was that the FreeHands was tested with HME filter and the iValve without. This could account for a difference in resistance through which the iValve is more easy to use.

### ***Clinical challenges***

Automatic speech valves can be connected to the stoma using adhesive patches. The pressure peak during the closure of the Freehands valve during initiation of speech could potentially apply stress between the patch and the peristomal area. The iValve did not show this behavior, which can be another benefit of this new valve, but this was not tested in this study. It must be noted that this iValve study is still a feasibility study, a proof of concept. If the challenges as mentioned above can be addressed then the iValve concept will be even more promising.



## Conclusion

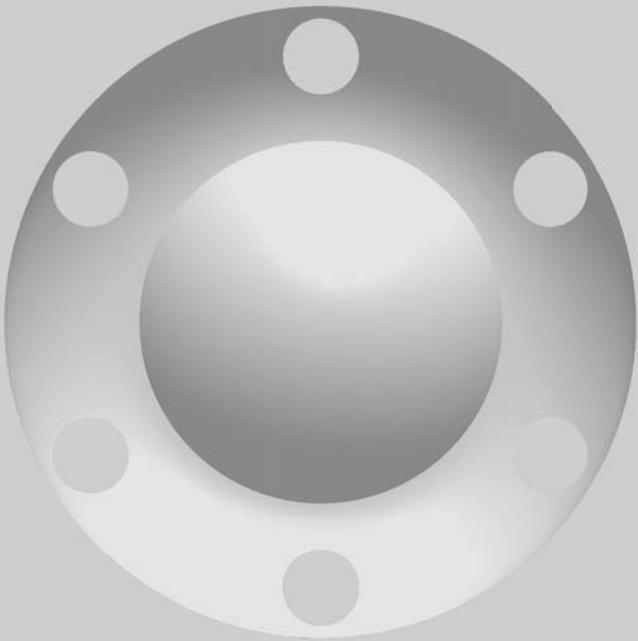
Based on aforementioned results, the new iValve proved to be comparable in performance to the existing FreeHands exhalation speech valve. An added feature of the iValve was the ability to whisper, which is not possible using the current exhalation valves. However, further engineering has to be performed to optimize the new inhalation valve. Still, during this feasibility study, the new valve has proven to be a viable design. With the air resistance addressed, the iValve is a more optimized product, which could help laryngectomy patients with improved hands free speech.

## Reference list

1. Op de Coul BM, Ackerstaff AH, van As-Brooks CJ, van den Hoogen FJ, Meeuwis CA, Manni JJ and Hilgers FJ. (2005) Compliance, quality of life and quantitative voice quality aspects of hands-free speech. *Acta Otolaryngol.* 6, 629-637.
2. Lorenz KJ, Groll K, Ackerstaff AH, Hilgers FJ and Maier H. (2007) Hands-free speech after surgical voice rehabilitation with a Provox((R)) voice prosthesis: experience with the Provox FreeHands HME tracheostoma valve((R)) system. *Eur. Arch. Otorhinolaryngol.* 2, 151-157.
3. Hilgers FJ, Ackerstaff AH, van As CJ, Balm AJ, Van den Brekel MW and Tan IB. (2003) Development and clinical assessment of a heat and moisture exchanger with a multi-magnet automatic tracheostoma valve (Provox FreeHands HME) for vocal and pulmonary rehabilitation after total laryngectomy. *Acta Otolaryngol.* 1, 91-99.
4. Ten Hallers EJ, Marres HA, Rakhorst G, Hagen R, Staffieri A, Van Der Laan BF, Van Der Houwen EB and Verkerke GJ. (2005) Difficulties in the fixation of prostheses for voice rehabilitation after laryngectomy. *Acta Otolaryngol.* 8, 804-813.
5. van den Hoogen FJ, Meeuwis C, Oudes MJ, Janssen P and Manni JJ. (1996) The Blom-Singer tracheostoma valve as a valuable addition in the rehabilitation of the laryngectomized patient. *Arch. Otorhinolaryngol.* 3, 126-129.
6. Geertsema AA, Schutte HK and Verkerke GJ. (2002) In vivo measurements of an improved tracheostoma valve based on inhalation. *Ann. Otol. Rhinol. Laryngol.* 2, 142-148.
7. Geertsema AA, Boonstra CW, Schutte HK and Verkerke GJ. (1999) Design and test of a new tracheostoma valve based on inhalation. *Arch. Otolaryngol. Head Neck Surg.* 6, 622-626.
8. van der Houwen EB, van Kalker TA, Burgerhof JG, van der Laan BF and Verkerke GJ. (2011) In vitro evaluation of the iValve: a novel hands-free speech valve. *Ann. Otol. Rhinol. Laryngol.* 12, 814-819.







# 8

## **General Discussion and Conclusions**

This chapter describes the presuppositions and overall results of studies described in this thesis and my view on the future developments in the field of voice restoration.

## **Current situation**

Tracheoesophageal speech using shunt prostheses has revolutionized vocal rehabilitation after total laryngectomy. The advantages of these devices are abundant and comprise high success rates and direct voice production with a more fluent quality than with esophageal speech. Tracheoesophageal speech has clearly improved the quality of life of laryngectomised patients. Even more so, since in combination with the use of an automatic speaking valve, it enables the possibility of hands-free speech, just like esophageal speech.

Despite hands-free speech being a more natural way of speaking, the pathway to hands-free voice production is not without hurdles. Several problems must be faced when a patient wants to use hands-free speech. The automatic speech valve must be attached to the tracheostoma in a reliable way. The stoma patch must have an airtight fit to the stoma skin. The stoma patches must be comfortable in use and limiting irritation to the skin.

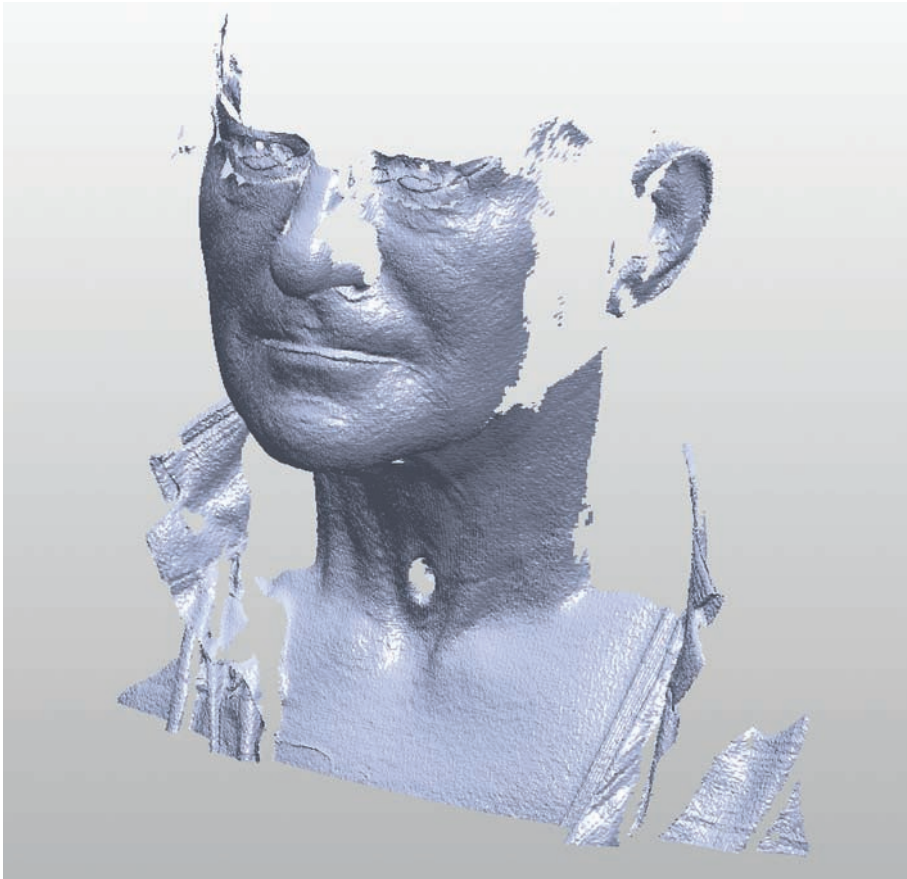
In addition, the current speech valves exert stress on the connection to the skin and lose valuable exhaled air during closure. Hands-free speech is therefore still not widely used.

## **The iPatch studies**

To be able to develop peristomal patches, the peristoma geometry study was essential. The knowledge of detailed actual dimensions of the stoma is a key factor as it presents requirements of peristomal devices in terms of shapes and variation in shapes. Furthermore, it gives clues why some current devices are prone to failure in some patients. To our knowledge no other studies are known describing the peristomal geometry in such detail than the one published in this thesis.

We had a wide variety of measurement methods at our disposal to measure the three-dimensional peristomal dimensions in house. The use of three-dimensional surface imaging technology is becoming increasingly common in craniofacial

clinics and anthropometric studies. Thanks to fast capture speeds and growing ease of use, 3D digital stereophotogrammetry is rapidly becoming a popular imaging modality. Another technique we contemplated was laser scanning that is, like stereophotogrammetry, well known and proven <sup>1,2</sup>. These systems can serve as a valuable tool generating an objective digital archive of the patient's face without exposure to radiation. An example of a laryngectomy patient rendering using the laser scanning technique is shown in Figure 1.



**Figure 1.** A 3D digital laser scan of the peristomal area. The scanner is a one point source, resulting in missing parts of the body that are in the shadow area of the laser and sensor.



However, acquiring consistent high-quality 3D captures requires planning and knowledge of these devices. The devices are still expensive, have a large footprint and must be set up and calibrated on site<sup>3</sup>. From a practical point of view, it was not possible to perform these measurements in a large worldwide setting. Moreover they do not give dimensions of the stoma, just a different representation of it.

Our attempts to model the peristomal area were therefore performed in a comparatively low-tech manner using a Vernier Calliper and flexible ruler. The attempt to keep it simple was proven valuable as different medical centres over the world could easily carry out the protocol in a reproducible way.

As can be seen in Chapter 2 we measured the peristomal area in a manual reproducible way and tried to detect differences in geometry within the range of 2 to 4 trachea rings removed during laryngectomy. The consensus was that when more trachea rings were removed, the stoma would become deeper due to traction of the trachea on the surrounding skin. This would negatively influence the attachment of the currently available flat stoma patches. However, we could not detect any differences. We anticipated a bias in different operation techniques. But surprisingly, after selecting only those patients who were operated in The Netherlands in a unified way we still could not detect any difference. Since the participating head and neck surgeon in The Netherlands were trained in the same clinic, the operation technique was considered not to be a biasing factor. However, we did not include removal of more than 4 trachea-rings in our study. So we can only conclude that stoma geometry was not influenced up to 4 removed trachea rings.

Additionally, we investigated if incision of the sternal attachment of the sternocleidomastoid would provide a more flush peristomal area. A flatter stoma could benefit the attachment of the currently available stoma patches. The same analyses were made as for the trachea-ring evaluations, as described above, to eliminate bias caused by the operation technique. Likewise, no significantly shallower (flatter) stomas were found in the group where incision of the SCM was made.

The authors are strong advocators of a well-implemented design of prosthesis used in the individual patient. And therefore we consider that a supporting device like a speech valve should be adapted to the patient and not the other way around: the patient should not be altered to fit a helping aid. When evaluating the measurements of the SCM groups, it was assumed that incision of the sternal

attachment of the SCM provided a more flat peristomal area, better suited for today's most used flat peristomal adhesive patches. Although the fold-to-fold distance seems larger, no significantly shallower stomas were found in the group where incision of the SCM was made. As a result, it is not demonstrated that cleaving the SCM during laryngectomy will result in a geometrically flatter stoma. Therefore, revision of the tracheostoma patch design should be desired over modification of the patient's anatomy before contemplating this invasive procedure.

Before we could design and test new tracheostoma patches using the clinical obtained data of the surrounding area of a tracheostoma, we had to determine the criteria upon which the patch should conform.

As we have seen, there are clear distinctions in tracheostoma patch-use worldwide. A major aspect can be addressed to whether there is a financial refund upon the tracheostoma devices. In reimbursed countries, patients are 6.4 times more likely to use a tracheostoma device than in non-reimbursing countries (9% versus 58%). The first criterion was therefore to create an inexpensive patch so that more patients (where there is no or little financial support for stoma aids) can benefit from its use.

The second criterion we determined was the ability of the patch to attach to irregular surfaces, caused by wrinkles, scars and skin folds. However, we found that wrinkles and folds (scars) induced no significant effect on overall patch use.

Our data shows a discrepancy in the actual stoma depth and the depth of the currently available tracheostoma patches. One of the current tracheostoma patches, the Provox Stabilibase, partly addresses this with an actual measured depth of 7.5-8 mm<sup>4</sup>. However, the mean stoma depth we measured worldwide was 13 mm. It is one of the factors of the large number of mentioned tracheostoma connector problems in literature. The third criterion in designing a new patch was to increase the depth to match the actual stoma geometry.

Additionally, the data showed that the peristomal area in non-patch users is smaller and thus reduces the usable space for glue retention. Our fourth criterion in designing the new patch was therefore to keep the area of contact to the skin as large as possible.

We were not interested in the best brand, but we wanted to know which feature made a certain patch superior to the other. Therefore we had to simulate the



skin around the tracheostoma. To keep consistency in our measurements, each tracheostoma patch was tested on an artificial skin. The skin was static and we did not use moisturised air. By this means we ruled out the effects of saliva, transpiration and movement of the neck.

During one normal speaking cycle it has a pressure-peak at initiation of speech caused by closure of the valve. A common pressure we measured during regular speaking was between 340 - 380 mm H<sub>2</sub>O, an equivalent of 3.3 - 3.7 kPa. In comparison, the intra-tracheal pressures throughout coughing with a closed tracheostoma increases to about 20 kPa.

During testing of the patches *in vitro*, none of the adhesives was able to reliably bear intra-tracheal pressures of 4.9 to 6.5 kPa. Every time during coughing, for a short period of time, the intra-tracheal pressure rises 3 times in excess of the maximum that stoma patches can withstand under a constant pressure. Although application of a constant pressure to a stoma patch is likely to cause failure at a lower pressure than a short burst, it is not an ideal situation for a reliable tracheostoma patch.

When using an automatic speech valve the patch is not counteracted by the force of a finger, as is the case in manually occluded tracheostoma valves. In other words there are large discrepancies in what intra-tracheal pressures stoma patches can endure and what design criteria are desired when using an automatic speech valve. This finding is in accordance with *in vivo* data in literature<sup>5-7</sup> where only 15-25% of patients were able to use a patch in combination with an automatic speech valve.

A new patch had to be designed after the above mentioned features gave novel insights into the peristomal anatomy and issues with the current peristomal patches. To this means the iPatch was designed and made. The first patch was funnel shaped. From our data in the worldwide study, we knew it was not ideal, as the actual shape of the stoma is teardrop shaped. However for ease of manufacturing and proof of concept we first tried a full symmetrical design. Even with this concept the patch performed well in terms of time it would stay fixed to the skin around the stoma.

An important issue in the first iPatch design was the attachment of the glue to the silicone rubber material that was unsatisfactory. It is well known that attachment to silicone rubber can be tough. Therefore we pre-treated the silicone rubber patches with plasma. However, during tests on patients the attachment of the

glue to the skin was still more powerful than the attachment to the silicone rubber patch. Furthermore, the patch is very thin with pliable edges. Application of glue to these edges proved to be a challenge. We are of the opinion that perfection of these features would result in an even better patch. It was therefore not long after the in vivo tests of the first iPatch when the first sketches of iPatch version 2 were made to tackle these problems with the design.

The lack of skin irritation and high comfort was (partly) due to the patch being made out of highly flexible silicone material. The choice for a thin silicone material was to make a better contact area to the skin and reduce sheer forces. In the end, even patients with a very delicate skin could wear the patch without any discomfort. Long term results and ease of removal of the iPatch have not been tested in our feasibility study. First results show potential and this new design could to be a valuable addition in a patient category that often had radiotherapy due to their laryngeal cancer.

## The iValve studies

We chose not to improve the currently speech valves as the current exhalation valves are evolved over many years and even the most recent and very complex exhalation valves cannot tackle the wide range of difficulties encountered by the laryngectomised patients. The exhalation valves waste valuable air during closure, leaving less air for longer sentences without using additional breaths. During speech, pressure should be maintained to prevent the valve from opening again, making pausing between words impossible. Magnets in the tip of the membrane and the housing of the FreeHands exhalation valve are partly solving this issue; they enable the membrane to stay closed with the slightest of exhalation pressure, and only release and thus allow the membrane to open at the onset of inhalation <sup>7</sup>.

Therefore we chose the principle of inhalation as introduced by Geertsema et al. The principle provides more air for phonation than exhalation valves and in this way we are able to increase the maximum phonation time. In addition, the valve does not have to be closed every time the patient wants to speak. It enabled the patient to pause during a normal sentence.





Chapter 6 describes the first experiences with the new design inhalation valve with patients. The first tests with the iValve were very successful. The first design proved to be at least as good as the Atos FreeHands valve. As assumed, the patients were able to stop talking mid-sentence and start talking again without closing the valve again.

Using the new iValve, patients no longer had to initiate speech using a powerful exhalation to close the speech valve. This enabled a slow airflow through the speech button, not introducing a mucosa vibration in the esophagus. Whispering was possible. We did not aim for this goal; a patient cheerfully showed us the way. However, we did not test if exhalation valves are able to achieve whispering. Further studies are needed.

## **The future of voice restoration**

The large database as presented in this thesis on tracheostoma anatomy, dictates valuable guidelines for a better tracheostoma patch design. The iPatch is a universal approach to a tracheostoma patch. It's design is mostly suited for patients who have a tracheostoma geometry close to the mean stoma geometry. We have also shown that patients who have a geometry which is on the remote ends of the spectrum do not perform as well in terms of adherence.

Additive manufacturing or 3D printing is a process of making a three-dimensional solid object of virtually any shape from a digital model. 3D printing is achieved using an additive process, where successive layers of material are laid down in different shapes.

Although this technique is not new and is quite well known, the possibilities and materials which can be used by 3D printing are vastly expanding at this time of writing. In particular the family of rubber-like materials that is becoming available offers a variety of elastomer characteristics. With the availability of 3D scanning it would be fascinating to see if an exact fitting flexible tracheostoma patch could be printed. Furthermore, it would be interesting to see if this patch would lead to a prolonged time of adherence.

The size of the first prototype iValve was perceived as too big according to a majority of patients. This, in addition to the opinion of patients that inhalation in

closed position is too difficult, made us redesign the first iValve prototype. The new iValve v2 is designed to address these challenges. Furthermore, efforts are made to include a heat and moisturising filter. We hope the iValve v2 is able to surpass the already capable exhalation valves. If so, more possibilities come into existence to improve quality of life for a large and diverse group of laryngectomy patients.

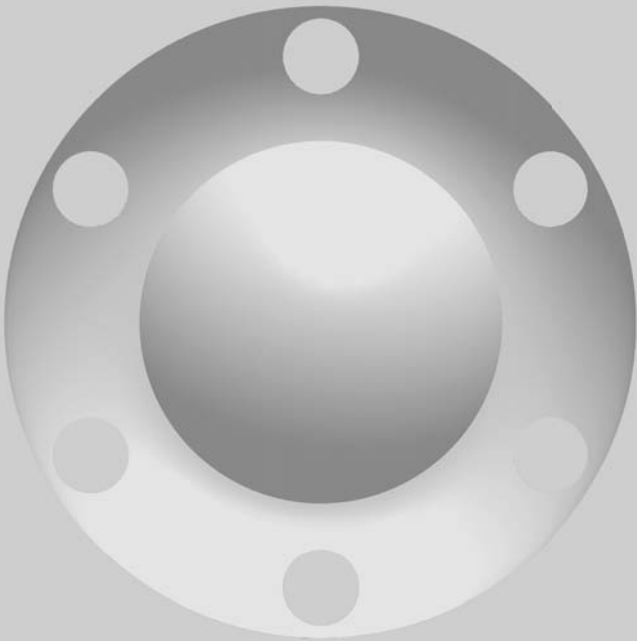
## Conclusion

Hands-free speech rehabilitation in laryngectomy patients remains a challenge. Therefore, I am very pleased that the new prototypes of the hands-free speech system (iPatch and iValve) works as well as it does. I am even more excited that we only scratched the surface of the potential of the system. With the current insights, the system has the prospective to be a state of the art hands-free speech system. Who knows how far future research will push these boundaries of speech rehabilitation.

## Reference list

1. Dirven R, Hilgers FJ, Plooi J, et al. 3D stereophotogrammetry for the assessment of tracheostoma anatomy. *Acta Otolaryngol* 2008;1-7.
2. Grolman W, Schouwenburg PF, Verbeeten B, Jr., de Boer MF, Meeuwis CA. Three-dimensional models of the tracheostoma using stereolithography. *ORL J Otorhinolaryngol Relat Spec* 1995;57:338-342.
3. Heike CL, Upson K, Stuhau E, Weinberg SM. 3D digital stereophotogrammetry: a practical guide to facial image acquisition. *Head Face Med* 2010;6:18-160X-6-18.
4. Hilgers FJ, Dirven R, Wouters Y, Jacobi I, Marres HA, van den Brekel MW. A multicenter, prospective, clinical trial evaluating a novel adhesive baseplate (Provox StabiliBase) for peristomal attachment of postlaryngectomy pulmonary and voice rehabilitation devices. *Laryngoscope* 2012;122:2447-2453.
5. Lorenz KJ, Groll K, Ackerstaff AH, Hilgers FJ, Maier H. Hands-free speech after surgical voice rehabilitation with a Provox((R)) voice prosthesis: experience with the Provox FreeHands HME tracheostoma valve((R)) system. *Eur Arch Otorhinolaryngol* 2007;264:151-157.
6. Bien S, Okla S, van As-Brooks CJ, Ackerstaff AH. The effect of a Heat and Moisture Exchanger (Provox HME) on pulmonary protection after total laryngectomy: a randomized controlled study. *Eur Arch Otorhinolaryngol* 2010;267:429-435.
7. Op de Coul BM, Ackerstaff AH, van As-Brooks CJ, et al. Compliance, quality of life and quantitative voice quality aspects of hands-free speech. *Acta Otolaryngol* 2005;125:629-637.





# 9

## Summary

Despite advances in conservative laryngeal surgery and radiotherapy, laryngectomy remains the treatment of choice for advanced-stage laryngeal carcinoma. As a result of this procedure, the patient is deprived of the normal sound-producing element. Furthermore, there is a permanent separation of the upper respiratory and digestive tracts. The trachea now ends at an artificially created opening in the neck, the tracheostoma. Due to the new anatomy of the trachea, the passageway to the nose is blocked which leads to the absence of pre-heated, filtered and moisturized air on inhalation. Both the inability to speak and the means to condition air have been shown to dramatically decrease the quality of life.

Laryngectomy patients generally benefit from conditioning of the inhaled air. This can be achieved by applying a heat and moisture exchanger onto the tracheostoma. Generally, two widely accepted fixation methods are available for attachment of tracheostoma aids: intra-tracheal devices or, the less invasive, adhesive stoma patches. A recognized difficulty in automatic tracheostoma valve use is its attachment to the tracheostoma. Adhesive patches are applied to attach the automatic tracheostoma valve to the soft tissue surrounding the stoma (peristomal area). The aim is to produce an airtight seal. The glue that this sealed remains fixed is very unpredictable. Factors influencing the duration of this seal are backpressure, phlegm production, sweat production and peristomal anatomy.

Patients who lose their larynx due to total laryngectomy can regain voice and speech in several ways. The best quality of voice and speech is obtained using a shunt valve. This type of speech restoration is also known as tracheoesophageal voice and speech. Voice and speech restoration by tracheoesophageal speech is achieved at a higher success rate as compared to esophageal speech.

The shunt valve is a one-way valve that operates as an artificial fistula connecting the trachea and esophagus. When the tracheostoma is occluded, the shunt valve allows air to be forced into the esophagus. This air induces vibration of the pharyngoesophageal mucosa and thus aids voice production and speech. However, this means of speech requires the patient to use his/her hand to occlude the tracheostoma. As a result, the patient needs at least one hand to initiate speech, which restricts mobility, points to the disability, and is deemed unhygienic. To tackle this problem, the first automatic tracheostoma valve was established in 1982, which reduced the need for digital closure of the tracheostoma.

During the subsequent 30 years (up until now) this type of automatic speech valve has not changed in its working principle. This category of automatic tracheostoma valve, which is open throughout normal breathing, relies on a short burst of exhaled air when the patient wants to initiate speech. This short burst of air causes closure of the automatic tracheostoma valve. During inhalation, the automatic tracheostoma valve opens again. As a short burst of air is needed to close the current automatic tracheostoma valves, its use is considered to exert substantial stress on the interface between the stoma and the valve.

To improve the fixation issue a new adhesive patch was developed with a geometry which is based upon the actual measured tracheostoma shape. To improve the tracheostoma valve issue, a new valve was developed, based on inhalation as closing mechanism.

In this thesis project the two new devices were tested in vitro and clinically.

To improve the automatic tracheostoma valve interface, one needs to know the basis upon which to build. The fundamental knowledge on tracheostoma geometry and its clinical influences is imperative (Chapter 2). Therefore, we studied the geometry of the peristomal area as it is changed by laryngectomy and investigated the effects of several factors on the peristomal geometry. We investigated whether the number of removed trachea rings, incision of the sternocleidomastoid muscles, neck dissection, reconstruction, time after operation, and age had any effect on the (peri)stomal geometry of the patient.

To this means (peri)stomas of 191 patients from 10 institutes worldwide were photographed, measured, and compared. We show that the number of removed tracheal rings during laryngectomy does not seem to influence stoma depth. This study also does not demonstrate that cleaving the sternocleidomastoid muscle (SCM) at the time of a laryngectomy will result in a geometrically flatter stoma.

In Chapter 3 we did address the need for laryngectomees to use adhesive patches on their stoma to connect filters and speech valves. These devices however, are not widely used. This is mainly attributed to a poor fit of the adhesive patches to the stoma site. Current patches are not based upon the (peri)stoma geometry of patients because the exact geometry of the tracheostoma is unknown.

This study investigates the geometry of (peri)stomas in relation to patch use. The study delivers data enabling improvement of tracheostoma interfaces, specifically



addressing patients currently unable to use stoma patches. For this means an observational anthropometric study of the (peri)stoma of laryngectomised patients was performed. The identical large worldwide multicenter patient cohort as in Chapter 2 was used. Next to the photographed and measured (peri)stomas, patients completed a questionnaire on patch-use. To compare the shape of the stoma to the currently available stoma patches, the concavity of commercially available patches was measured. We found that in countries with a financial reimbursement system 58% of the patients use patches in comparison to only 9% in other countries. Patches stay in situ for an average of 33.3 hours. Patch and non-patch users differ on five out of ten measured geometrical parameters. Most prominent differences are that patch users have much shallower peristomas (13 versus 18 mm), and stomas are far more parallel to the anterior neck plane. The deepest commercially available patch (Provox StaBilibase) is 7.5-8 mm deep. Therefore this study provides detailed (peri)stoma geometry data of a diverse population, and for the first time in relation to patch-use. It reveals a serious mismatch between patients and patches. With these data a new patch was developed that might improve rehabilitation after laryngectomy.

In addition to stoma geometry, the adhesion to the stoma site is a contributing factor in the lifetime of stoma patches. At this time of writing it is unknown which adhesive system is preferable.

In Chapter 4 both for possible clinical and research purposes, a general more patient friendly, over-the-counter prosthesis adhesive was tested in vitro on artificial skins and compared to four other commercially available adhesive patches. In order to gather these data, a special test setup was build. The median maximum failure pressure for this tested general adhesive (Principality G601), was shown to be 2.75 kPa. This is comparable to the failure pressure of the other four tested, commercially available adhesive patches.

In Chapter 5 we did test a flexible, funnel shaped tracheostoma patch for laryngectomy patients. This new design is based upon new insights into the peristomal skin geometry (Chapter 2 and 3). The novel tracheostoma patch is designed to have a more natural fit to the peristomal anatomy of the laryngectomy patient facilitating maximum comfort. The performance goal was a patch in situ lifetime of 12 hours or longer when provided with a commonly used stoma filter.

The new tracheostoma patch was tested on 28 laryngectomy patients. The tracheostoma geometry of every patient was measured, as described in Chapter 1. Patients used the new patch as long as it would stay in situ in combination with a commercially available HME cassette. Throughout the use of the stoma patch, patients kept a journal to register their experiences and time and date of applying and removing the patch.

The patch prototypes stayed in situ with a mean of 34.5 hours. For patients with a mean depth of the tracheostoma of more than 11 mm, the mean patch in situ time increased to 48.6 hours. 25 (89%) Patients experienced no or very little irritation of the skin using the new tracheostoma patch, partly because it was made out of extremely thin flexible silicone rubber, which causes less sheer-stress on the skin. Mean in situ lifetime of the new patch was longer in patients with a deep stoma, although not significantly. Furthermore, the major improvement of the new silicone patch was the ability to induce limited skin irritation. Within the conceptual framework the patch has proven to be a viable design.

In Chapter 6 we performed in vitro evaluation of a novel, disposable, automatic hands-free tracheostoma speech valve for laryngectomy patients based upon the principle of inhalation. The commercially available automatic speech valves close upon strong exhalation and open again when the pressure drops. This method has the disadvantage that the subsequent inhalation opens the valve again; as a result constant phonation is not achievable. Furthermore, current automatic tracheostoma valves have the disadvantage that exhaled breathing air is spent for closure of the tracheostoma valve, leaving less air for phonation. To challenge these problems a new tracheostoma valve has been developed that is closed by fast inhalation in contrast to exhalation. The novel i(nhalation)Valve is designed to allow almost natural speech, allowing mid-sentence pausing and offers the patient the possibility of whispering.

To test the valve in vitro, the inhalation closing flows and exhalation opening pressures of 6 iValve prototype versions at different settings were compared with physiological values. The airflow resistance at inhalation was compared to physiological and commercial valve values.

During these tests, the iValve prototypes showed a flow and pressure range in concordance with the physiological values in literature. The airflow resistance in the breathing mode was within the physiological airflow resistance range, yet above the values from the two commercial valves. The resistance in speaking





mode was above the physiological airflow resistance range.

Therefore we conclude that these in vitro tests show that the iValve versions can be selected and adjusted to operate within physiological range. The airflow resistance in the breathing mode is good. In speaking mode inhalation should, and can, be decreased. An example is when a HME filter will be incorporated, adding more resistance. The iValve should offer the patient a useable alternative, and its low cost allows disposability and wider use.

In Chapter 7 a study is presented in which the prototype iValve was tested on patients. Furthermore the iValve was compared to the current most widely used exhalation tracheostoma valve, the Atos Provox® Free Hands HME.

The new iValve was comparable in performance to the Atos Provox® Free Hands HME. In addition, it appeared that patients were able to whisper using the iValve.

As proof of concept, the iValve has demonstrated to be a viable design. The iValve has more potential; therefore this valve will be further developed. In the new version the inhalation resistance will be reduced, the overall dimensions will be more compact and it will be linked to a HME. The aim is to make the valve with its intrinsic benefits available to patients.

## Samenvatting

Ondanks ontwikkelingen in strottenhoofd (larynx) chirurgie en radiotherapie blijft het volledig verwijderen van het strottenhoofd (laryngectomie) de eerste keus van behandeling bij een vergevorderd stadium van keelkanker (larynxcarcinoom). Een gevolg van deze ingreep voor de patiënt is dat het normale geluids-producerende element (de stemplooiën) is verwijderd. Daarnaast is er een permanente scheiding van de bovenste luchtweg (trachea) en slokdarm (oesophagus). De luchtpijp eindigt nu in een kunstmatig gecreëerde opening in de hals, het tracheostoma. Door de nieuwe anatomie van de luchtpijp is de ademweg naar de neus geblokkeerd, wat leidt tot afwezigheid van voorverwarmde, gefilterde en bevochtigde lucht tijdens inhalatie. Zowel de onmogelijkheid tot spreken als de middelen om de ademplucht te conditioneren hebben de kwaliteit van leven aantoonbaar verminderd.

Gelaryngectomeerde patiënten hebben voordeel bij conditionering van de ingeademde lucht. Dit kan worden bereikt door het toepassen van heat and moisture exchangers (filters) op het tracheostoma.

Globaal zijn er twee algemeen geaccepteerde methoden voor de bevestiging van tracheostoma-hulpmiddelen: intra-tracheale canules of de minder invasieve tracheostoma pleisters. Met behulp van pleisters wordt de tracheostoma-klep aan de omliggende huid van het tracheostoma bevestigd (peristomale gebied). Het doel is het creëren van een luchtdichte afsluiting. Een bekend probleem bij tracheostoma-kleppen is de bevestiging aan het tracheostoma. De tijdsduur dat deze fixatiemethode luchtdicht is, varieert erg van patiënt tot patiënt. Factoren die de tijdsduur van deze afsluiting bepalen zijn tegendruk op de pleister tijdens praten of hoesten, mucus productie en peristomale anatomie.

Patiënten die hun stembanden verliezen als gevolg van een totale laryngectomie kunnen op verschillende manieren hun stem herwinnen. De beste stemkwaliteit wordt verkregen door gebruik te maken van een tracheo-oesofageale klep. Dit type spraak wordt ook wel tracheo-oesofageale spraak genoemd. Spraakrevalidatie door tracheo-oesofageale spraak heeft een hoger succespercentage dan oesofageale spraak.

De tracheo-oesofageale spraakklep is een eenrichtingsklep die werkt als een kunstmatig gangetje tussen luchtpijp en slokdarm. Wanneer het tracheostoma wordt afgesloten, zorgt de tracheo-oesofageale spraakklep ervoor dat lucht



in de slokdarm wordt gedrukt. Deze lucht veroorzaakt trilling van de faryngo-oesofageale mucosa en draagt hiermee bij tot de grondtoon die gebuikt wordt voor spraakvorming.

Echter, deze manier van spreken betekent dat de patiënt zijn of haar hand moet gebruiken om het tracheostoma af te sluiten. Hierdoor is tijdens spraak altijd een hand in gebruik. Dit beperkt de mobiliteit, legt nadruk op de handicap en is onhygiënisch. Om dit probleem te beteugelen is in 1982 de eerste automatische tracheostoma klep ontworpen, wat de handmatige afsluiting van het stoma overbodig maakte.

In de daarop volgende 30 jaar (tot op heden) is dit type automatische spreekklep onveranderd in zijn werkingsprincipe. Deze categorie automatische spreekkleppen, welke open zijn bij normaal ademen, zijn gebaseerd op een korte uitademingstoot als de patiënt wil gaan spreken. Deze korte uitademingstoot veroorzaakt sluiting van de automatische spreekklep. Tijdens inademing opent de automatische spreekklep weer. Doordat een korte uitademingstoot nodig is om de huidige generatie automatische spreekkleppen te sluiten, oefenen deze kleppen aanzienlijke spanning uit op het contactvlak tussen het stoma en de klep.

Om het fixatie probleem te verbeteren werd een nieuwe tracheostoma pleister ontwikkeld met een geometrie wat gebaseerd is op de werkelijke gemeten stoma vorm. Om de tracheostoma kleppen te verbeteren werd een nieuwe klep ontwikkeld, gebaseerd op inhalatie als sluitingsmechanisme.

In dit proefschrift worden de twee nieuwe hulpmiddelen in vitro en klinisch getest.

Om bevestiging van de automatische spreekkleppen te verbeteren, is het nodig te weten wat de basis is waarop verder gebouwd kan worden. Een grondige kennis van de tracheostoma geometrie en informatie over welke klinische factoren hierop uitwerking hebben is een vereiste. Om dit doel te bereiken hebben we de geometrie van het peristomale gebied onderzocht en bepaald welke klinische factoren hier een invloed op uitoefenen (Hoofdstuk 2). De volgende factoren zijn daarbij in acht genomen; het aantal verwijderde tracheeringen, incisie van de musculus sternocleidomastoideus, halsklierdissectie, reconstructie en tijd na operatie. Ook is bepaald of er een relatie was met de peristomale geometrie van de patiënt.

Hiervoor zijn de (peri)stoma's van 191 patiënten van 10 wereldwijde medische centra gefotografeerd, gemeten en vergeleken. We tonen aan dat het aantal verwijderde

trachearingen tijdens laryngectomie de diepte van het stoma niet beïnvloedt. Deze studie toont ook niet aan dat het klieven van de musculus sternocleidomastoideus tijdens laryngectomie resulteert in een geometrisch vlakker stoma.

In Hoofdstuk 3 behandelen we de noodzaak voor gelaryngectomeerden om stomapleisters te gebruiken teneinde filters en automatische spreekkleppen te plaatsen. Deze hulpmiddelen worden echter niet wijdverbreid gebruikt. Dit wordt voornamelijk toegeschreven aan beperkte pasvorm van de stomapleisters op het peristoma. De huidige stomapleisters zijn niet gebaseerd op de (peri)stoma geometrie van patiënten, gezien deze geometrie onbekend is.

Deze studie onderzoekt de geometrie van het (peri)stoma in relatie tot het pleister gebruik. Het levert data op die de bevestiging aan het tracheostoma oppervlak zouden kunnen verbeteren. Hierbij wordt nadruk gelegd op patiënten die niet in staat zijn om stomapleisters te gebruiken. Om dit doel te bereiken is een observationeel antropometrische studie van het (peri)stoma verricht. Er is gebruik gemaakt van het relatief grote wereldwijde patiënten cohort zoals omschreven in Hoofdstuk 2. In aanvulling op de gefotografeerde en gemeten (peri)stomas, hebben patiënten een vragenlijst ingevuld over stomapleister gebruik. Om de geometrie van het stoma te vergelijken met de huidige meest gebruikte stomapleisters is de concaviteit van deze pleisters gemeten.

We vonden dat in landen waarbij er een financieel vergoedingssysteem aanwezig was, 58% van de patiënten stomapleisters gebruikt en slechts 9% in de andere landen. Stomapleisters blijven gemiddeld 33 uur in situ. Pleister en niet-pleister gebruikers verschillen op 5 van de 10 gemeten geometrische parameters. De meest uitgesproken verschillen zijn dat pleister gebruikers een veel nauwer peristoma hebben (13 versus 18 mm) en de stoma's staan veel meer parallel ten opzichte van het anterieure hals vlak. De diepste commercieel verkrijgbare pleister (Provox StaBilibase) is 7,5-8 mm diep. Hierdoor biedt deze studie gedetailleerde informatie over (peri)stomale geometrie van een grote, diverse populatie en dit voor het eerst in relatie tot stomapleister gebruik. Het openbaart een ernstige discrepantie tussen patiënten en pleisters. Met deze nieuwe gegevens is een nieuw stomapleister ontwikkeld die de revalidatie na laryngectomie kan verbeteren.

In aanvulling op de stoma geometrie is de kleeftkracht aan het peristoma een bijdragende factor in de levensduur van stomapleisters. Op dit moment van schrijven is het onbekend welk kleefstelsel de voorkeur geniet.



In Hoofdstuk 4 wordt zowel voor klinische- als in onderzoeksdoeleinden een vrij verkrijgbare prothese lijm in vitro getest op kunsthuiden en vergeleken met vier andere commercieel verkrijgbare stoma pleisters. Om deze data te meten werd een speciaal voor dit doel ontwikkelde testopstelling gebouwd. De mediaan van de maximale druk waarbij de geteste lijm (Principality G601) losliet was 2.75 kPa. Dit is vergelijkbaar met de loslaat druk van de overige vier geteste, commercieel verkrijgbare stoma pleisters.

In Hoofdstuk 5 testten we een nieuw ontwikkelde flexibele, trechtervormige stomapleister voor gelaryngectomeerden. Dit nieuwe ontwerp is gebaseerd op nieuwe inzichten in (peri)stomale geometrie (Hoofdstuk 2 en 3). De nieuwe tracheostoma pleister is ontworpen om een meer natuurlijke pasvorm te hebben ten opzichte van de peristomale anatomie van de gelaryngectomeerde patiënt waardoor het draagcomfort geoptimaliseerd wordt. Het beoogde doel was een pleistertijd in situ van 12 uur of langer, wanneer deze wordt uitgerust met een standaard toegepast stomafilter.

De nieuwe tracheostoma pleister werd getest bij 28 gelaryngectomeerde patiënten. De tracheostoma geometrie van elke patiënt werd gemeten analoog aan de methode omschreven in Hoofdstuk 2. Patiënten gebruikten de nieuwe pleister zo lang als hij in situ wilde blijven zitten in combinatie met een commercieel verkrijgbare filtercassette. Patiënten hielden een logboek bij tijdens het dragen van de nieuwe pleister en registreerden daarbij hun ervaringen en tijd/datum van aanbrengen en verwijderen.

De pleister prototypen bleven gemiddeld 34,5 uur zitten. Bij patiënten met een gemiddelde diepte van het stoma van meer dan 11 mm, was de gemiddelde tijdsduur in situ 48,6 uur. 25 (89%) Patiënten ondervonden geen of erg weinig irritatie van de huid met de nieuwe tracheostoma pleister, mede gezien het feit dat de pleister gemaakt was van extreem dun flexibel siliconenrubber wat minder afschuifkrachten veroorzaakt. De gemiddelde levensduur van de nieuwe pleister was langer bij patiënten met een diep stoma, dit effect was echter niet significant. Daarnaast is de grootste verbetering van het nieuwe prototype pleister dat het zeer weinig huidirritatie induceert. Binnen de beoogde doelen heeft de nieuwe pleister zich bewezen als een haalbaar concept.

In Hoofdstuk 6 wordt een in vitro evaluatie uitgevoerd van een nieuw ontworpen, disposable, automatische tracheostoma spreekklep voor gelaryngectomeerden

gebaseerd op het concept van inhalatie. De commercieel verkrijgbare automatische spreekkleppen sluiten bij sterke exhalatie en openen weer als de druk vermindert. Deze methode heeft het nadeel dat de volgende inhalatie de klep weer opent; een gevolg is dat constante fonatie niet mogelijk is. Daarnaast hebben de huidige automatische tracheostomakleppen het nadeel dat uitademingslucht wordt gebruikt om de klep te sluiten waardoor er minder lucht over is voor fonatie. Om deze problemen te ondervangen is een nieuwe tracheostomaklep ontwikkeld die sluit bij snelle inhalatie in plaats van exhalatie. De nieuwe inhalatie klep, hierna iValve genoemd, is ontworpen om een zo natuurlijk mogelijke spraak mogelijk te maken. De nieuwe klep staat toe dat er in het midden van een zin gepauzeerd kan worden en biedt de patiënt de mogelijkheid tot fluisteren.

Om deze nieuwe klep in vitro te testen, zijn luchtdrukken en -stromingen gemeten, waarbij de klep sluit bij 6 verschillende iValve prototypen. Deze metingen zijn vergeleken met de fysiologische waarden. De luchtweerstand tijdens inhalatie is verder vergeleken met fysiologische waarden en die van commercieel verkrijgbare kleppen.

Tijdens deze tests toonden de iValve prototypen een luchtstroom en drukrange in overeenkomst met fysiologische waarden, gevonden in de literatuur. De luchtweerstand in de ademstand was binnen de fysiologische waarden, echter boven de waarden van twee commercieel verkrijgbare kleppen.

De luchtweerstand in de spreekstand was boven de fysiologische waarden.

Hieruit concluderen wij dat deze laboratoriumtesten aantonen dat de verschillende iValve versies geselecteerd en aangepast kunnen worden om te kunnen gebruiken binnen de fysiologische waarden in de patiënt. De luchtstroomweerstand in de ademstand is goed. In de spraakstand moet, en kan, deze weerstand tijdens inhalatie verminderd worden. Dit is bijvoorbeeld van belang wanneer de iValve in combinatie met een HME filter zal worden gebruikt welke een extra weerstand vormt. De iValve kan de patiënt een bruikbaar alternatief bieden en de lage productie kosten staan disposable en een breder gebruik toe.

In Hoofdstuk 7 wordt een studie getoond waarin het prototype van de iValve wordt getest bij patiënten. Daarnaast werd de iValve vergeleken met de huidige meest gebruikte exhalatie tracheostoma klep, de Atos Provox® Free Hands HME. De nieuwe iValve was vergelijkbaar in prestaties ten opzichte van de Atos Provox® Free Hands HME. In aanvulling hierop bleek dat patiënten in staat waren om te fluisteren met de iValve.



Binnen de beoogde doelen heeft de iValve zich bewezen als een haalbaar concept. De iValve heeft meer potentieel, daarom zal deze klep verder worden ontwikkeld. In de nieuwe versie zal de inhalatieweerstand worden verminderd, de algehele afmetingen worden compacter en zal worden gecombineerd met een HME filter. Het oogmerk is om de klep met zijn inherente voordelen beschikbaar te maken voor patiënten.

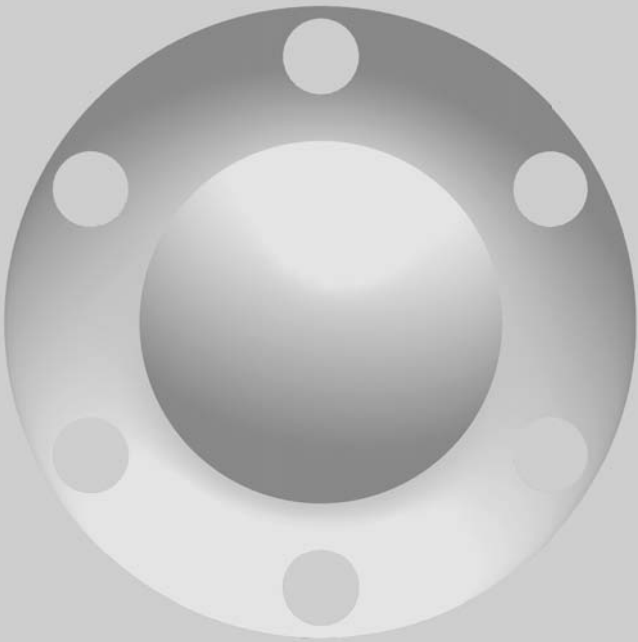


Scan de QR code om een uitzending te bekijken waarin het prototype van de iValve wordt gedemonstreerd.

Het Academisch Ziekenhuis, TELEAC, 20 apr 2010, Afl. 4.







# Dankwoord

Het schrijven van dit proefschrift zou onmogelijk zijn geweest zonder de hulp van derden. Een aantal mensen ben ik zeer erkentelijk voor hun rol die ze gespeeld hebben bij het tot stand komen van dit proefschrift.

Prof. dr. B.F.A.M. van der Laan, beste Bernard. Mijn promotor en tevens opleider. Met je inhoudelijke kennis en inzicht ben je onmisbaar geweest voor de tot stand koming van dit proefschrift. Als ik ergens in vastliep, inspireerde je me doordat je denkt in mogelijkheden en niet in belemmeringen. Je betrokkenheid, in het bijzonder bij de afronding van dit proefschrift, ondervond ik als zeer waardevol en ik ben je hier zeer erkentelijk voor. Ook wil ik je bedanken voor je inzet tijdens mijn KNO-opleiding. Ik ben verheugd dat ik breed wordt opgeleid in een goede kliniek en zie uit naar een mooie toekomst als KNO-arts.

Prof. dr. ir. G.J. Verkerke, beste Bart, mijn promotor. In de loop der jaren heb ik veel waardering gekregen voor je heldere adviezen. Je hebt de gave om complexe zaken op een praktische manier te benaderen. Hierdoor wist je vaak de cultuurkloof te dichten tussen inzichten van een medicus en een ingenieur. Je liet zien dat het ontwerpen van producten geen triviale aangelegenheid is en dat er vele facetten zijn waarmee rekening gehouden moet worden. Deze brede blik op het proces zorgde voor de realisatie van een succesvol eindresultaat, de iValve en de iPatch.

Prof. dr. F.J.M. Hilgers, beste Frans, naast dat je lid bent van mijn beoordelingscommissie, was je ook co-auteur van twee artikelen. Je was een belangrijke en betrokken adviseur voor mijn manuscript. Door je brede ervaring waren je adviezen scherp, maar altijd opbouwend en erop gericht om het onderzoek te verbeteren. Ik wil je graag bedanken voor je inspanningen waardoor het proefschrift aanzienlijk in kwaliteit gewonnen heeft.

Prof.dr.P.U.Dijkstra en Prof.dr.G.Rakhorst, waarde leden van de manuscriptcommissie, veel dank voor uw bereidheid het manuscript deskundig te beoordelen.

Dr. ir. E.B. van der Houwen, beste Ward, paranimf, co-auteur, ontwerper en dichter, de titel van doctor heb je al een jaar eerder ruimschoots verdiend. We hebben het onderzoek als een dubbeltraject doorlopen. Onze samenwerking heb ik altijd als zeer vanzelfsprekend en prettig ervaren. Je brede interesse en charisma was hierin onmisbaar naast de vele motiverende gesprekken die we samen hebben gevoerd.

Nu het proefschrift af is heb ik vaker tijd om wat mee te gaan drinken. Bedankt dat je mijn paranimf wilt zijn.

Dr. W. Post, beste Wendy, dit proefschrift zou statistisch minder significant zijn zonder je hulp. Dank je voor je enthousiaste begeleiding en mooie verhalen tijdens de methodologische opzet en analyses van de verschillende studies.

Dear Co-authors, dear Mrs. Hebe, dr. Lawson, prof. Mostafa, dr. Marioni, dr. Martínez, dr. Ruske, dr. Schulz, dr. Woisard. Many thanks for your help during the currently largest international multi-center tracheostoma geometry study. It was a great success due to your efforts and a pleasure to work with all of you. I hope we can continue our collaboration in the future.

(Oud-)studenten, Minke van den Berge, Lützen Kuiper, Rik Mencke, Willemijne Schrijvers en Agnes Uittewaal, bedankt voor jullie onbetaalbare bijdrage aan mijn onderzoek, de mooie verhalen, de gezelligheid en vriendschap. Jullie hebben dit project de moeite waard gemaakt!

Veel dank aan alle gelaryngectomeerde patiënten die zeer bereidwillig waren om mee te werken aan onze studies. In het bijzonder zou ik de heer De Groot, mevrouw Drenth en de heer De Bruine willen bedanken. De heer De Groot, beste Fokko, dank voor je niet aflatende interesse en medewerking bij de metingen tijdens de vele patiëntenbijeenkomsten. Mevrouw Drenth, beste Liesbeth, bedankt voor je medewerking, acteerwerk tijdens het TV-debuut van de iValve en vooral je bezielende elan. De heer De Bruine, beste Ad, je staat altijd klaar om de ontwikkelingen rondom gelaryngectomeerden een stap vooruit te helpen. Door jullie hulp zijn al onze metingen en het testen van de prototypen zonder problemen verlopen.

Sponsors, Atos, "Stichting Tonny en Luit Baflo" en "Stichting Familie Stol Hoeksema", ben ik zeer erkentelijk voor het leveren van de ondersteuning op financieel gebied en in de vorm van materiaal voor mijn onderzoek.

Alle medewerkers van de poli KNO en in het bijzonder Rebecca Baldal, Geert Busscher, Marianne Duits en Lieneke Klei, naast de klinische werkzaamheden wil ik jullie bedanken voor jullie hulp tijdens de metingen.



F. Leemhuis, beste Frits, elektronicus, je vanzelfsprekendheid tot hulp was erg belangrijk. Ontzettend bedankt hiervoor.

Opleidingsgroep UMCG, naast promoveren is de opleiding zeer waardevol. De sfeer en het opleidingsklimaat is bijzonder goed. Ik hoop dat mijn laatste jaar net zo leerzaam zal zijn als de voorgaande jaren.

Opleidingsgroep MCL dank ik voor een geweldig perifeer jaar. Ik heb genoten van de prettige werksfeer en heb bovenal ontzettend veel van jullie geleerd.

(Oud)-assistenten KNO UMCG, beste Bertram, Charlotte, Christina, Ellen, Emiel, Francka, Henry-Jaques, Hilke, Hugo, Jacolien, Janine, Janke, Jasper, Kevin, Kim, Leonie, Leontien, Maartje, Marloes, Michel, Michiel, Noortje Schwandt, Noortje Smale, Nynke, Perry, Robin, Rutger, Sanaz, Thomas, Tom, Willem en Wouter. Bedankt voor de goede sfeer op de werkvloer, maar vooral ook voor het inkleuren van de vele mooie momenten tijdens de vrijdagmiddagborrels en jaarlijkse ski- en zeilweekenden. In het bijzonder wil ik Leontien bedanken. Ik heb ons jaar op een onderzoekskamer als zeer ontspannen en leerzaam ervaren. Toen ik vanuit het midden des lands plots in het hoge noorden belandde was jij het die me enthousiast opving. Je maakte me wegwijs in Groningen, de mores binnen de KNO en liet me kennis maken met de schaatscultuur. Mijn proefschrift is af en die van jou zal zeer snel volgen. Ik weet zeker dat het een fantastisch werk wordt en wens je veel succes!

Prof. dr. H.F. Mahieu, beste Hans, mijn eerste voorzichtige stappen in het wetenschappelijk onderzoek zijn door jou begeleid. Zonder je bezielende enthousiasme voor wetenschappelijk onderzoek zou dit proefschrift er niet zijn geweest.

Fabian, we hebben sinds 1992 een compleet ander pad bewandeld. Je vriendschap is me dierbaar en ik vind het mooi dat daarbij afstand geen rol speelt. Bedankt dat je tijdens deze dag aan mijn zijde wilt staan.

Mijn broertje, Gilbert, ik vind het enorm waardevol dat we zo'n gemakkelijke en goede band hebben. Nu het proefschrift is afgerond zijn mijn weekenden weer vrij. Hopelijk heb ook jij weer tijd om samen onze auto af te bouwen.

Mijn ouders, lieve papa en mama, jullie eeuwige belangstelling, onvoorwaardelijke steun en liefde zijn onmisbaar geweest bij alles wat ik tot nu toe heb bereikt. Jullie hechten waarde aan nieuwsgierigheid, creativiteit en de kunst van iets zelf maken. Deze basis hebben jullie me gegeven. De afstand tussen Groningen en Zoelen maakt een bezoekje niet altijd gemakkelijk. Als blijk van waardering heb ik dit proefschrift aan jullie opgedragen, jullie zijn me dierbaar.



## Curriculum Vitae



Tjouwke van Kalker werd op 19 juli 1978 geboren te Zoelen. Na zijn lagere school ging hij naar het RSG Lingecollege in Tiel waar hij in 1996 zijn eindexamen HAVO en in 1998 zijn VWO-examen behaalde. Hierna werd hij een jaar uitgeloot voor de studie Geneeskunde. In dat jaar heeft hij zijn propedeuse Werktuigbouwkunde behaald aan de Technische Universiteit Eindhoven. In 1999 startte hij met zijn studie Geneeskunde aan de Universiteit Maastricht. Na in 2003 zijn doctoraalfase te hebben beëindigd liep hij zijn co-assistentchap in diverse ziekenhuizen in Limburg, Brabant en in latere

fase buiten de Nederlandse grenzen in India en Thailand. Tijdens deze periode werd zijn aandacht getrokken naar de KNO-heelkunde. Eind 2005 behaalde hij zijn artsexamen. Aansluitend begon hij als Arts-onderzoeker op de KNO-afdeling van het Meander Medisch Centrum te Amersfoort alwaar hij, onder directe begeleiding van prof.dr.H.F. Mahieu, heeft bijgedragen aan de ontwikkeling van een kymograaf (digitale high-speed camera om stemplooi trillingen in beeld te brengen). In 2007 startte hij als Arts-onderzoeker bij de afdeling KNO in het UMC Groningen en deed onder leiding van prof.dr.B.F.A.M. van der Laan en prof.dr.ir.G.J. Verkerke onderzoek naar tracheostoma geometrie, een nieuw ontwerp stoma pleister en een nieuwe hands-free spreekklep voor gelaryngectomeerde patiënten. Het onderzoek heeft hij als een dubbeltraject doorlopen samen met dr.ir.W. van der Houwen, die in 2012 op de technische kant van dit onderzoek is gepromoveerd, wat uiteindelijk heeft geleid tot het tot stand komen van dit meer klinisch georiënteerde proefschrift. Sinds november 2009 is hij in opleiding tot KNO-arts in het UMC Groningen, het perifere deel van de KNO opleiding werd in het MC Leeuwarden gelopen.





