

University of Groningen

## Maturation pathway of nisin and other lantibiotics

Vos, Willem M. de; Kuipers, Oscar P.; Siezen, Roland J.

*Published in:*  
Molecular Microbiology

*DOI:*  
[10.1111/j.1365-2958.1995.mmi\\_17030427.x](https://doi.org/10.1111/j.1365-2958.1995.mmi_17030427.x)

**IMPORTANT NOTE: You are advised to consult the publisher's version (publisher's PDF) if you wish to cite from it. Please check the document version below.**

*Document Version*  
Publisher's PDF, also known as Version of record

*Publication date:*  
1995

[Link to publication in University of Groningen/UMCG research database](#)

*Citation for published version (APA):*

Vos, W. M. D., Kuipers, O. P., & Siezen, R. J. (1995). Maturation pathway of nisin and other lantibiotics: post-translationally modified antimicrobial peptides exported by Gram-positive bacteria. *Molecular Microbiology*, 17(3). [https://doi.org/10.1111/j.1365-2958.1995.mmi\\_17030427.x](https://doi.org/10.1111/j.1365-2958.1995.mmi_17030427.x)

### Copyright

Other than for strictly personal use, it is not permitted to download or to forward/distribute the text or part of it without the consent of the author(s) and/or copyright holder(s), unless the work is under an open content license (like Creative Commons).

The publication may also be distributed here under the terms of Article 25fa of the Dutch Copyright Act, indicated by the "Taverne" license. More information can be found on the University of Groningen website: <https://www.rug.nl/library/open-access/self-archiving-pure/taverne-amendment>.

### Take-down policy

If you believe that this document breaches copyright please contact us providing details, and we will remove access to the work immediately and investigate your claim.

*Downloaded from the University of Groningen/UMCG research database (Pure): <http://www.rug.nl/research/portal>. For technical reasons the number of authors shown on this cover page is limited to 10 maximum.*

## MicroReview

# Maturation pathway of nisin and other lantibiotics: post-translationally modified antimicrobial peptides exported by Gram-positive bacteria

Willem M. de Vos,\* Oscar P. Kuipers,  
Jan Roelof van der Meer<sup>†</sup> and Roland J. Siezen  
Department of Biophysical Chemistry, NIZO, PO Box 20,  
6710 BA Ede, The Netherlands.

### Summary

Lantibiotics form a family of highly modified peptides which are secreted by several Gram-positive bacteria. They exhibit antimicrobial activity, mainly against other Gram-positive bacteria, by forming pores in the cellular membrane. These antimicrobial peptides are ribosomally synthesized and contain leader peptides which do not show the characteristics of signal sequences. Several amino acid residues of the precursor lantibiotic are enzymatically modified, whereafter secretion and processing of the leader peptide takes place, yielding the active antimicrobial substance. For several lantibiotics the gene clusters encoding biosynthetic enzymes, translocator proteins, self-protection proteins, processing enzymes and regulatory proteins have been identified. This *MicroReview* describes the current knowledge about the biosynthetic, immunity and regulatory processes leading to lantibiotic production. Most of the attention is focused on the lantibiotic nisin, which is produced by the food-grade bacterium *Lactococcus lactis* and is widely used as a preservative in the food industry.

### Introduction

Many bacteria secrete ribosomally synthesized polypeptides that show antagonistic activity against their competitors. Some of these are large proteins that kill closely related bacteria and conform to the original definition of bacteriocins (Tagg *et al.*, 1976). However, in recent years an increasing number of small antimicrobial peptides has

been identified that have a wider host range (Kolter and Moreno, 1992). These antagonistic peptides, which are usually cysteine-rich and hydrophobic, include microcins, lantibiotics, and other heat-stable peptides. Whilst microcins, such as microcin B17 and colicin V, are made by members of the Enterobacteriaceae (Baquero and Moreno, 1984), the other antimicrobial peptides are exclusively produced by Gram-positive bacteria (Klaenhammer, 1993; Jung, 1991). In particular, heat-stable peptides secreted by lactic acid bacteria have received considerable attention because of their potential as natural food preservatives. The lantibiotics include a growing list of modified peptides with unique structures produced by bacilli, lactococci, lactobacilli, staphylococci, streptococci, and streptomycetes (Fig. 1; Jung, 1991). Well-studied examples of non-lantibiotics are pediocin PA-1, lacticin F, and the narrow-host-range peptide lactococcin A produced by *Pediococcus acidilacti*, *Lactobacillus acidophilus*, and *Lactococcus lactis*, respectively (Marugg *et al.*, 1992; Fremaux *et al.*, 1993; Holo *et al.*, 1991). In spite of the phylogenetic heterogeneity of the producers, which include both Gram-negative and Gram-positive bacteria, all of these antimicrobial peptides are ribosomally synthesized with N-terminal extensions that do not conform to a consensus *sec*-dependent signal sequence and instead are transported in a process that probably involves ABC exporters (Fath and Kolter, 1993).

An important property that differentiates the antimicrobial peptides is the degree of post-translational intramolecular modification that extends beyond the formation of common disulphide bridges. Microcins and heat-stable peptides are not subject to such post-translational modifications, with the exception of microcin B17, a glycine-rich peptide that contains modified cysteine, serine and glycine residues forming directly connected heteroaromatic rings (Bayer *et al.*, 1993; Yorgey *et al.*, 1993). In contrast, it has been established that lantibiotics are subject to a series of sequential post-translational modifications (Schnell *et al.*, 1988). Lantibiotics constitute an unusual class of biologically active peptides that contain both dehydrated amino acids and lanthionine residues, forming intramolecular thioether rings (Jung, 1991; see Fig. 1). These monosulphide bridges determine the

Received 10 May, 1994; revised 13 April, 1995; accepted 24 April, 1995. <sup>†</sup>Present address: EAWAG-ETH CH-8600 Dübendorf, Switzerland. \*For correspondence. E-mail nizobfc1@caos.kun.nl or willem.devos@algemeen.micr.wau.nl; Tel. (31) 83 80 59 558; Fax (31) 83 80 50 400.

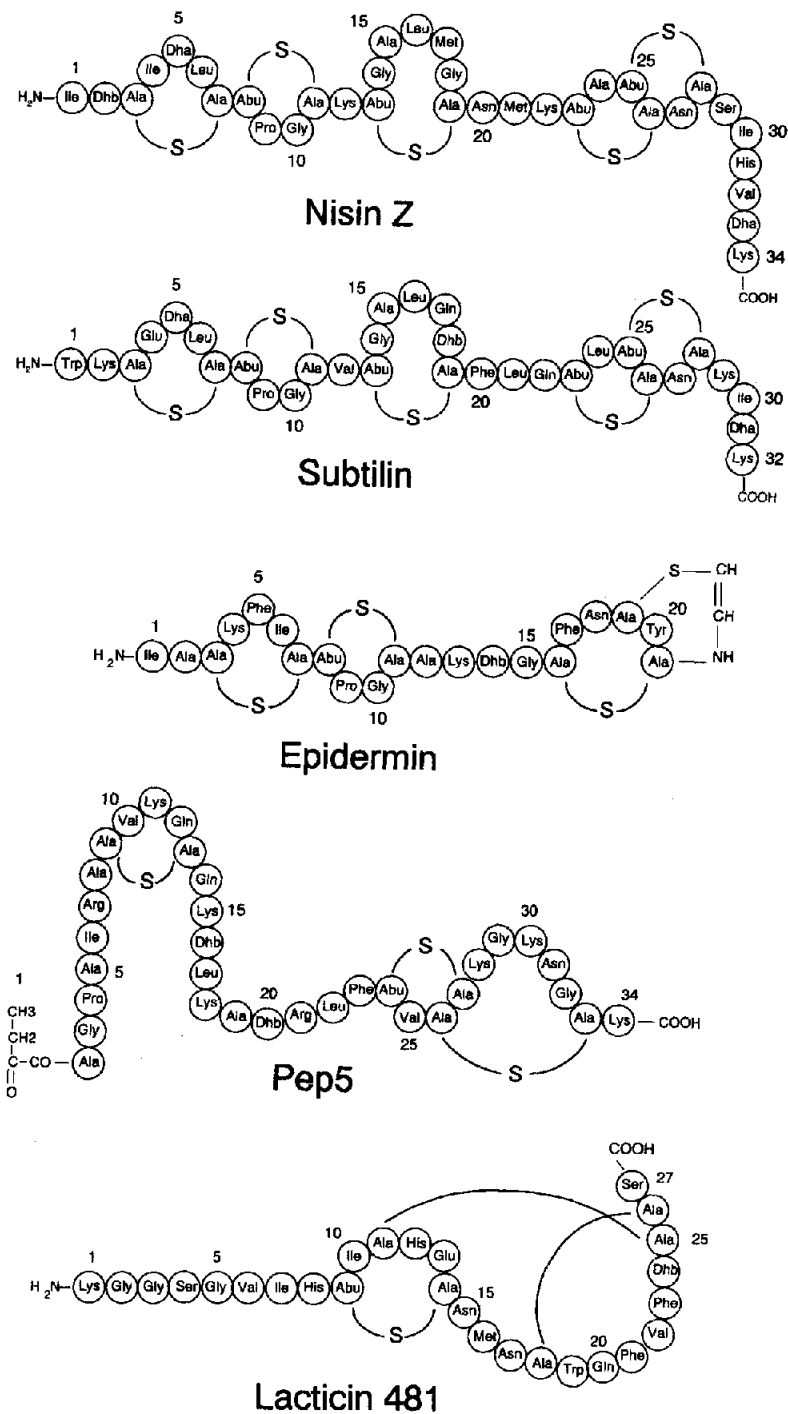

**Fig. 1.** Schematic representation of the structures of linear lantibiotics nisin Z, subtilin, epidermin and Pep5 (Jung, 1991). The structure of lactacin 481 has not been completely solved and only one of the two possible structures is shown (Piard *et al.*, 1993). The nomenclature of unusual amino acids has been described previously (Jung, 1991; de Vos *et al.*, 1991).

characteristic polycyclic structures of lantibiotics and their intrachain position has been used to group these antimicrobial peptides into linear (Group A) and circular (Group B) lantibiotics (Jung, 1991). The unique properties of lantibiotics have generated considerable interest in the structure–function relationships of these antimicrobial peptides that are known to form transient, potential-dependent pores in the bacterial cytoplasmic membranes (Sahl,

1991). In addition, the specificity and biochemistry of the reactions that underlie the post-translational modifications of lantibiotics have received significant attention, especially as they have the potential to extend the genetic code and generate novel residues in polypeptides. Finally, lantibiotics can be produced efficiently and hence are excellent model compounds for the study of the export of small peptides in bacteria.

The first lantibiotic structure to be unravelled was that of nisin, a 34-residue peptide (Gross and Morell, 1971). Nisin was discovered 50 years ago as an inhibitory substance produced by a strain of *L. lactis* (Mattick and Hirsch, 1944). Since then, many primary discoveries in the field of antimicrobial peptides have involved nisin, a situation that has been greatly stimulated by the increasing application of nisin in the food industry (de Vos, 1993). These events include the identification of the sequence and transcription of the nisin structural gene (Buchman *et al.*, 1988), the determination of the spatial structure of nisin in solution (van de Ven *et al.*, 1991), and the construction and characterization of the first nisin mutants generated by protein engineering (Kuipers *et al.*, 1992). In this review we address the recent progress made in the genetic and biomolecular characterization of the post-translational modification, dedicated export, immunity, and proteolytic processing of nisin and other linear (Group A) lantibiotics with known structures such as epidermin, subtilin, Pep5, and lactacin 481 (Fig. 1). For a more complete review, see Sahl *et al.* (1995).

### Structural genes for nisin and other linear lantibiotics

At present, two natural variants of nisin are known, designated nisin A and nisin Z (Gross and Morell, 1971; Mulders *et al.*, 1991; de Vos *et al.*, 1993). Single lactococcal strains make only one nisin variant and both nisin A and nisin Z producers are widely distributed (de Vos *et al.*, 1993). The variants differ at residue 27 (histidine in nisin A and asparagine in nisin Z; Fig. 1) and their structural genes *nisA* and *nisZ*, respectively, have been characterized (Buchman *et al.*, 1988; Kaletta and Entian, 1989; Mulders *et al.*, 1991). The predicted 57-residue peptide, designated pre-nisin, contains a 23-residue N-terminal leader part which is absent in mature nisin, and a 34-residue C-terminal part designated pro-nisin (Fig. 2; for lantibiotic nomenclature see Schnell *et al.*, 1988; Jung, 1991; de Vos *et al.*, 1991).

The structural genes of several other linear (Group A) lantibiotics have also been characterized in recent years and all contain leader and pro-lantibiotic sequences (Fig. 2). While the pro-peptides are subject to various, and probably sequential, post-translational modification reactions, recent studies in which intermediates were characterized have shown that the Pep5 and nisin leader sequences are not modified, apart from the occasional removal of the N-terminal methionine (Weil *et al.*, 1990; van der Meer *et al.*, 1993; 1994; Kuipers *et al.*, 1993b). Whilst sequences in both the leader and the pro-lantibiotic part could account for this difference in modification, it is likely that the N-terminal leader sequence, which is the first to be synthesized and at some stage is removed, may have a specific role in the post-translational modification and targeting processes.

### Linear lantibiotics contain two classes of leader peptides

Comparison of the lantibiotic leader sequences (Fig. 2) shows that they are hydrophilic, highly charged, and often contain a charged residue following the initiator methionine. In contrast to the cysteine-rich pro-regions, the leader sequences are devoid of cysteine residues. Based on similarities in the size, net charge and sequence of the leaders, the presently known linear (Group A) lantibiotics can be classified into two main groups, i.e. Class AI and Class All (Fig. 2).

Class AI includes leaders with a slightly positive or negative net charge that contain several conserved residues. Mutation analysis of the nisin leader has shown that some of those conserved amino acids, including a serine at position -6 and several residues in the so-called FNLDV box, are essential for nisin modification, secretion or both (van der Meer *et al.*, 1994; see below). Class All includes leader peptides with, in general, a highly negative net charge that do not contain a sequence resembling the characteristic FNLDV box. In contrast, those leaders contain consensus sequences that are not found in the Class AI leader sequences.

Apart from the distinct signature sequences, the Group AI and All leaders also differ in the residues that precede the pro-lantibiotic part. In the Class AI leaders these residues are charged and contain a conserved proline residue. Cleavage of the nisin leader was shown to be catalysed by a dedicated extracellular serine protease as the last step in nisin biosynthesis (van der Meer *et al.*, 1993). Site-directed mutagenesis and molecular modelling studies have shown that whilst the conserved proline is not essential for leader cleavage, a positively charged residue at position -1 and a small hydrophobic residue at position -4 are essential (van der Meer *et al.*, 1994; Siezen *et al.*, 1995). In contrast, the listed Class All leaders contain a GA/GS/GG sequence immediately preceding the cleavage site and conserved ELS/EVS and EL/EM sequences. Unexpectedly, this Class All leader sequences show considerable similarities with leaders of non-lantibiotic peptides produced by Gram-positive bacteria, such as pediocin, lactacin F and lactococcin A, and that of colicin V produced by *Escherichia coli* (Havarstein *et al.*, 1994). Site-directed mutagenesis studies of leader processing sites have shown that export levels of colicin V or lactacin F are decreased by mutations G-2D, G-2R or G-2S (Gilson *et al.*, 1990; Klaenhammer, 1993). The colicin V leader peptide is essential for translocation and is cleaved during export (Gilson *et al.*, 1990; Fath and Kolter, 1993). Based on these results, it is tempting to speculate that the listed leader peptides of the Class All lantibiotics and that of the non-lantibiotics are processed by a peptidase with a similar specificity and location.

	leader peptide	▼	prolantibiotic
Class AI			
	* * *	*	
nisin A	MSTKDF <b>FN</b> LDLVS---VSKKDSG-ASPR		ITSISLCTPGCKTGALMGCNMKTATCCHCSIHVSK
nisin Z	MSTKDF <b>FN</b> LDLVS---VSKKDSG-ASPR		ITSISLCTPGCKTGALMGCNMKTATCNCSEHVSK
subtilin	MSKFDD <b>FD</b> LDVVK---VSKQDSK-ITPQ		WKSESLCTPGCVTGALQTCFLQTLTCNCKISK
epidermin	MEAVKEKNDL <b>FN</b> LDVKNAKESN-DSG-AEPR		IASKFICTPGCAKTGSFNSYCC
gallidermin	MEAVKEKNEL <b>FD</b> LDVKNAKESN-DSG-AEPR		IASKFLCTPGCAKTGSFNSYCC
pep5	MKNNK <b>N</b> LDLEIKK--ETSQ-NTDELEPQ		TAGPAIRASVKQCKQLKATRLFTVSCGKNGCK
epilancin K7	MNNSL <b>FD</b> LNLNK-GVETQ-KSD-LEPQ		SASVLKTSIKVSKKYCKGVTLTCGNITGGK
consensus leader	<b>FN</b> LDV            S    DS    PR		
	D                    T    KT    Q		
Class AII			
lacticin 481	MKEQNSFN <b>LLQ</b> EVTESELDLILGA		KGSGVIHTISHECNMNSWQFVFTCCS
streptococcin A-FF2	MEKNNEVIN <b>SIQ</b> EVSLLELDQIIIGA		GKNGVFKTISHECHLNTWAFLATCCS
salivaricin A	MNAMKNSKDILN <b>NAIE</b> EVSEKELMEVAGG		KRSGWIATITDDCPNSVFVCC
cytolysin L1	MENLSV <b>VP</b> SFEELSVEEMEAIQGS		GDVQAETTPVCAVAATAASSAACGWVGGIFTGVTVVSLKHC
cytolysin L2	VLNKENQEN <b>Y</b> SNKLELVGPSFEELSLEEMEAIQGS		GDVQAETTPACFTIGLVGALFSAKFC
consensus leader		<b>EVS EL I GA</b>	
		LT M V S	

**Fig. 2.** Alignment of leader and pro-peptides of lantibiotics compared with that of non-lantibiotics. Lantibiotics with Class AI leaders include nisin A and nisin Z from different strains of *L. lactis* (Buchman *et al.*, 1988; Mulders *et al.*, 1991), subtilin from *B. subtilis* (Banerjee and Hansen, 1988), epidermin, gallidermin and Pep5 from various *Staphylococcus epidermidis* strains (Schnell *et al.*, 1988; Kaletta *et al.*, 1989; Schnell *et al.*, 1989). Lantibiotics with a Class AII leader include lacticin 481 from *L. lactis* (Piard *et al.*, 1993), streptococcin A-FF2 from *Streptococcus* sp. (Ross *et al.*, 1993), salivaricin from *Streptococcus salivarius* (Hynes *et al.*, 1993), and cytolysin L1 and L2 from *Enterococcus faecalis* (Gilmore *et al.*, 1994). Fully conserved residues in both classes of leaders and cysteine residues in the pro-lantibiotic part that are all involved in lanthionine and  $\beta$ -methyl lanthionine formation are indicated in bold. Consensus residues are shown below the two classes of leaders while essential residues in the nisin leader are indicated by stars (van der Meer *et al.*, 1994).

Recently, a new lantibiotic has been characterized, lactocin S, which also has a Class AII leader peptide with the conserved ELS element, but lacks the glycine-rich cleavage site, suggesting an alternative proteolytic cleavage (Skaugen *et al.*, 1994).

#### Common post-translational modifications in the pro-region of linear lantibiotics

Comparison of the sequences of pro-lantibiotics with the structures of the corresponding mature linear lantibiotics allowed the identification of the residues that were subject to dehydration and subsequent reactions or participating in other post-translational modifications at the N- and C-terminus (Figs 1 and 2).

One or more unsaturated amino acids (dehydroalanine and dehydrobutyrine) are found in all lantibiotics and appear to be derived from serine and threonine residues, respectively (Jung, 1991); these dehydrated residues may subsequently undergo stereospecific nucleophilic addition

by the sulphhydryl group of a cysteine residue to form the characteristic lanthionine or  $\beta$ -methyl-lanthionine, respectively. Alternatively, they may remain as dehydrated residues in the lantibiotic. In the lantibiotic lactocin S a novel modification has recently been discovered in which some of the dehydrated serine residues are converted, probably via a hydrogenation reaction, into D-alanine residues (Skaugen *et al.*, 1994).

The chemical modification reactions leading to the typical lanthionines were first proposed by Ingram (1970) and are assumed to be catalysed by specific enzymes encoded by the lantibiotic genes. However, the nucleophilic addition might be a chemical reaction as suggested by recent results in which a sequence mimicking the second (B) ring of epidermin was shown to cyclize spontaneously via a stereoselective intramolecular addition generating (2S,6R)-lanthionine that is found in all linear lantibiotics (Toogood, 1993). Whatever the nature of this reaction, the nucleophilic addition of the sulphhydryl group leading to the formation of thioether bonds in

linear lantibiotics shows a striking polarity from a cysteine residue to a more N-terminally located dehydro-residue, reflecting a common mechanism.

Apart from the modification reactions that involve the formation of dehydrated residues, two other types of post-translational modifications are known in lantibiotics (see Fig. 1). In some lantibiotics such as Pep5 and epidermin K7, the N-terminal threonine and serine residues are modified into 2-oxy-butyryl and 2-hydroxyl-pyruvyl residues, respectively (Kellner *et al.*, 1989; van de Kamp *et al.*, 1995). In addition, the C-terminal cysteine residues of epidermin and the related gallidermin are modified into S-[(Z)-2-aminovinyl]-D-cysteine (Schnell *et al.*, 1988; Schnell, 1989; Kupke *et al.*, 1992).

### Organization of genes involved in the biosynthesis of nisin and other linear lantibiotics

Chromosome analysis in conjunction with transfer and curing studies have indicated that the production of nisin, the immunity to nisin, and the capacity to ferment sucrose are located on an unstable genetic element that was identified as a 70 kb conjugative transposon in *L. lactis* NIZO R5 (Rauch and de Vos, 1992). The organization, excision and integration of the nisin A transposon Tn5276 from this strain has been characterized and can be considered as the prototype of a novel family of large nisin–sucrose elements, which includes other nisin A transposons (such as Tn5301) from other strains, and nisin Z transposons (such as Tn5278) (Horn *et al.*, 1991; Rauch *et al.*, 1994).

The sequence and transcription of the Tn5276 13 kb nisin gene cluster has been determined (Fig. 3; Kuipers

*et al.*, 1993a; van der Meer *et al.*, 1993; de Vos *et al.*, 1995). The Tn5276 *nisABTCIPRK* gene cluster is similar in organization and sequence to the clusters recently characterized from *L. lactis* strains 6F3 and N8, which produce nisin A and nisin Z, respectively (Engelke *et al.*, 1994; Immonen *et al.*, 1995).

The gene clusters flanking the structural genes for various other lantibiotics have been characterized (Fig. 3). The best-studied representatives are those of nisin, subtilin, epidermin and Pep5, each containing Class AI leaders, and cytolysin and lactacin 481, which contain Class AII leader peptides (Fig. 2).

Mutation analysis has shown that there is a single structural lantibiotic gene that can be complemented *in trans* in the case of epidermin (Augustin *et al.*, 1992), subtilin (Liu and Hansen, 1992), and nisin (Dodd *et al.*, 1992; Kuipers *et al.*, 1993a). However, deletion and complementation studies have recently shown that the cytolysin gene cluster contains two tandem structural genes (here designated *cylA1* and *cylA2*; Fig. 3) that are both required for the cytolytic activity (Gilmore *et al.*, 1994). Apart from an internal repeat, these *cyl* genes do not share common sequences, which contrasts with the complete duplication of the structural gene for streptococcin A that was recently observed in various strains of *Streptococcus pyogenes* (Hynes *et al.*, 1994).

In addition to the conjugative nisin–sucrose transposons, the lantibiotic gene clusters are often found on unstable genetic elements and a plasmid location has been shown for the genes for epidermin, Pep5, cytolysin and lactacin 481 production. This has allowed the simple isolation of isogenic mutants that were deficient in lantibiotic production. Some of these mutants have been

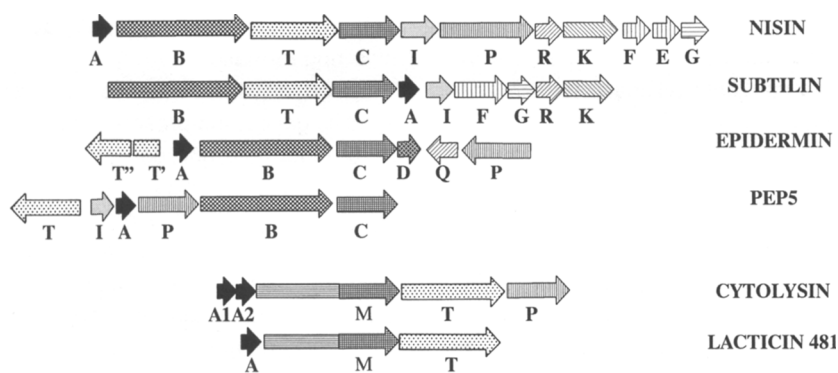

**Fig. 3.** Organization of lantibiotic operons. Following the proposed nomenclature (de Vos *et al.*, 1991), genes encoded in the lantibiotic operons have the following locus symbols: *nis*, nisin (Kuipers *et al.*, 1993a; Engelke *et al.*, 1994; Siegers and Entian, 1995); *spa*, subtilin (Klein *et al.*, 1992; 1993; Klein and Entian, 1994); *epi*, epidermin (Schnell *et al.*, 1992); *pep*, Pep5 (Reis *et al.*, 1994; H.-G. Sahl, personal communication); *cyl*, cytolysin (Gilmore *et al.*, 1994); *lct*, lactacin 481 (Piard *et al.*, 1993; Rince *et al.*, 1994). Individual genes are distinguished by capital letters, A being used for the structural gene. Identical capitals are used for genes encoding similar functions as deduced from functional analysis or sequence conservation. The presumed functions include modifying enzymes (B, C or M), oxidative decarboxylation (D), immunity (I), leader peptidase (P), export (T), regulation (R, K, and Q), and accessory self-protection (FG or EFG). Note that other nomenclature has been used in some of the original literature, i.e. for *spa*, *cyl* and *lct* genes. Similar shading indicates sequence conservation; structural genes are all black.

partially or completely complemented by the lantibiotic gene clusters, showing that the production of nisin requires the *nisABTCIPR* genes (van der Meer *et al.*, 1993) while the *cylA1A2CTP* genes are necessary for the production of cytolysin (Gilmore *et al.*, 1994). Moreover, the *epiABCDQP* genes are required for the production of epidermin in a heterologous host (Augustin *et al.*, 1992). Although the involvement of chromosomal genes cannot be excluded, these complementation experiments suggest that the presently identified gene clusters contain all the necessary information for the production of nisin, epidermin and cytolysin.

While the lantibiotic gene clusters show a characteristic and unique organization, they have the capacity to code for proteins with considerable sequence similarity to those found to be produced by the nisin genes (indicated by similar shading in Fig. 3). The genes that show sequence similarity or analogous functions have received the same gene designations, which conform with the agreements made at the 1st and 2nd International Workshops on Lantibiotics, although other designations have been used in early literature (see de Vos *et al.*, 1991). These include the *nisB* gene and the distal *nisC* gene, which are probably involved in modification, the *nisT* gene encoding a protein with high similarity to ABC exporters, the *nisI* gene specifying a lipoprotein involved in nisin immunity, the *nisP* gene coding for a serine protease involved in leader processing, and, finally, the *nisRK* genes coding for a two-component regulatory system (see below).

### Two classes of dedicated, lantibiotic-specific proteins are likely to be involved in common post-translational modification reactions

The nisin gene cluster contains two genes, *nisB* and *nisC*, that code for 993- and 414-residue proteins, respectively, with no significant overall homology to other proteins in the present databases. Remarkably, all characterized lantibiotic gene clusters contain a gene that could encode a protein with sequence homology to NisC, and this property was used to align the clusters in Fig. 3. While the *spa*, *epi* and *pep* clusters have the capacity to code for proteins similar in size and sequence to both NisC and NisB, the *cyl* and *lct* gene clusters may encode 993- and 922-residue proteins, designated CylM and LctM, respectively, that contain a C-terminal domain with striking homology to NisC (Gilmore *et al.*, 1994; Siezen *et al.*, 1995). The presence of a common set of genes encoding proteins with a conserved sequence is likely to reflect the common reactions in the maturation pathways of lantibiotics. Mutation studies have suggested that the genes for the NisB, NisC and CylM family of proteins are essential for the production of functional lantibiotics and may be involved in the dehydration and thioether bond

formation. When either *nisB*, *epiB* or *spaB* was disrupted, production of the corresponding lantibiotic was completely abolished (Klein *et al.*, 1992; Augustin *et al.*, 1992; Chung and Hansen, 1992; O. P. Kuipers *et al.*, manuscript in preparation). Similarly, mutations in the *nisC* and *epiC* genes have led to impaired production of nisin and epidermin, respectively (O. P. Kuipers *et al.*, manuscript in preparation; Augustin *et al.*, 1992). Finally, it was recently found that disruption of *lctM* destroyed the production of lactacin 481 and inactivation of *cylM* abolished production of cytolysin (Rince *et al.*, 1994; Gilmore *et al.*, 1994). However, as no precursors have been identified and characterized in these mutants, any conclusions about the reaction that is catalysed by these conserved proteins remain speculative.

Careful homology searches showed that the N-terminal domains of the CylM and LctM proteins do not show any significant similarity to NisB and its homologues, excluding the possibility of a fusion between their respective genes. In addition, no other proteins were found in protein databases that had a significant resemblance to those belonging to the NisB, NisC or CylM family of proteins. Computational secondary-structure predictions indicated that all of these contain membrane-spanning hydrophobic regions, and recent experimental evidence confirmed that NisB and SpaB are membrane-bound (Engelke *et al.*, 1992; Gutowski-Eckel *et al.*, 1994). Limited similarity was reported between NisB and *E. coli* llvA, a threonine dehydratase, and hence a possible dehydratase function for the NisB-like proteins has been suggested (Gutowski-Eckel *et al.*, 1994). If this is correct, this leads to the speculation that NisC-like proteins are involved in the enzyme-catalysed formation of thioether bonds from the dehydrated residues and cysteine. Similarly, it could be envisaged that the CylM protein and its homologues combine the role of dehydratase and the enzymatic activity leading to lanthionine ring formation.

Based on the sequence and size of the lantibiotic-specific genes, the presently identified gene clusters may be grouped into one containing homologues of the *nisB* and *nisC* genes, and another containing no *nisC* homologue but an extended *nisB*-like gene, such as *cylM* or *lctM* (Fig. 3). There is a striking correlation between this grouping and the classification of lantibiotics based on the differences in leader sequence (Fig. 2). This implies that the linear lantibiotics can be grouped into two classes based both on the characteristics of their leader sequence and on the presence of conserved genes in their gene cluster. Complete sequence analysis of gene clusters encoding other lantibiotics with Class AI or Class AII leaders is needed to further substantiate this classification. Nevertheless, it is tempting to assume that this dichotomy reflects an interaction between the homologues of NisC and/or NisB with the Class AI leader peptides on

one hand, and an interaction between the enlarged proteins of the CylM family and the Class All leader peptides on the other. In what way this interaction takes place and what roles the characteristic signature elements of the two classes of leader peptides play in this interaction remain to be elucidated. However, mutation analysis of the conserved FNLDV box has led to the suggestion that the leader sequence of nisin plays a role in either recognition of, or binding to, lantibiotic-modifying enzymes, together with other functions such as maintaining the precursor in an inactive form (van der Meer *et al.*, 1993; 1994). In line with this hypothesis is the recent finding that substitution of the nisin leader by that of subtilin resulted in a completely and correctly matured nisin species, indicating that functional exchange is possible between the Class AI leaders (Kuipers *et al.*, 1993b).

### Export and activation of nisin and other (pre)lantibiotics: roles of NisT and NisP

Two nisin genes, *nisT* and *nisP*, encode proteins with identified functions that are also found to be encoded by other lantibiotic gene clusters. The *nisT* gene encodes a 600-residue protein with strong homology to ABC exporters (Engelke *et al.*, 1992; Kuipers *et al.*, 1993a). ABC exporters share two main regions of homology, i.e. an ATP-binding motif in the C-terminal half, and the membrane-spanning domains in the N-terminal half, suggesting that for secretion ATP hydrolysis is required as a source of energy (Fath and Kolter, 1993). The domains responsible for substrate recognition have not been identified. Related genes for ABC exporters are found in all other lantibiotic gene clusters investigated (Fig. 3). It is likely that those translocators are involved in the export of (precursors of) the lantibiotics. This has been conclusively demonstrated for the export of cytolysin CylT was the first ABC exporter identified in Gram-positive bacteria (Gilmore *et al.*, 1990). As expected, introduction of an in-frame deletion in the N-terminal part of NisT abolished the production of nisin (O. P. Kuipers *et al.*, unpublished). However, a *spaT* disruption mutant of *Bacillus subtilis* was able to produce subtilin but had a clumpy phenotype and became non-viable at a later growth phase (Klein *et al.*, 1992). Although this phenotype was interpreted as indicative of a defective translocation system, it also suggested the presence of an alternative export system for which recent evidence is provided (see below).

There is a single gene for the ABC exporter in the lantibiotic gene clusters, except in the case of the *epi* gene cluster, which contains an interrupted *epiT* gene. However, this does not preclude the production of a functional ABC exporter, and the corresponding gene in the related gallidermin gene cluster does not appear to be interrupted

(Schnell, 1989). ABC exporters are also required for the translocation of colicin V and other non-lantibiotic antimicrobial peptides such as pediocin PA-1 (Marugg *et al.*, 1992), and lactococcin A (Stoddard *et al.*, 1992). However, in these systems another accessory gene with deduced homology to HlyC is present and it has been shown that export of these non-lantibiotics requires both the ABC exporter and the accessory genes (Fath and Kolter, 1993).

The *nisP* gene has been shown to encode an extracellular serine protease. The deduced protein sequence of NisP contains an N-terminal signal sequence and a C-terminal membrane anchor, indicative of secretion followed by anchoring to the cell membrane (van der Meer *et al.*, 1993). Various lines of evidence have been provided supporting the conclusion that extracellular removal of the nisin leader peptide by NisP is the last step in the biosynthesis of nisin. One piece of evidence is based on the detailed characterization of an extracellular intermediate, designated precursor nisin, that consists of the non-modified nisin leader and a fully modified pro-nisin part. This precursor nisin was first isolated from a *L. lactis* strain that contained an incomplete *nisP* gene (van der Meer *et al.*, 1993). Precursor nisin was devoid of biological activity but could be activated by incubation with cell membranes from a *nisP*-expressing strain, indicating that the activating NisP protease is membrane-located as was expected from the presence of characteristic topogenic sequences. Remarkably, the presence of nisin precursor was also observed early during growth of nisin-producing strains (van der Meer *et al.*, 1994). Other support for the role of NisP in cleaving nisin precursors was provided by the observation that mutations in the nisin leader peptide at positions -4 or -1 resulted in the secretion of unprocessed nisin precursors, probably because of the inability of the NisP protease to productively bind the modified precursor in its substrate-binding region (van der Meer *et al.*, 1994). This notion was strengthened by molecular modelling of precursors in the active site of NisP, which indicated that a hydrophobic residue at position -4 and a positively charged residue at position -1 (Siezen *et al.*, 1995; see Fig. 2) were necessary. Finally, a nisin precursor peptide containing the leader of the homologous lantibiotic subtilin was effectively transported into the culture medium, probably not being processed because of the presence of a glutamine residue at position -1 (Kuipers *et al.*, 1993b). Taken together with the predicted location of NisP at the outer side of the bacterial membrane, and the *in vitro* actual processing of native nisin A precursor by whole cells expressing *nisP*, it can be concluded that the fully modified precursor peptide is translocated and then processed by NisP.

The cellular location of processing by a dedicated leader



peptidase may differ according to the lantibiotic. The homologous EpiP and CylP proteins also contain a signal sequence but lack an anchor, suggesting that they operate extracellularly, either attached to the cell wall in another fashion or not attached at all. The putative peptidase PepP of the *pep* operon lacks both a signal sequence and an anchor, and may function intracellularly, which is compatible with the N-terminal modification of Pep5. Finally, the *spa* gene cluster does not contain a peptidase-like gene (Fig. 3). However, the subtilin producer *B. subtilis* is known to contain a variety of secreted serine proteases that could be involved in the proteolytic activation. Because of the great similarity between the nisin and subtilin systems and the functional exchange of their leaders, it is likely that this proteolytic cleavage of the subtilin leader sequence also will take place outside the *B. subtilis* cells.

#### Immunity: role of immunity proteins such as the lipoprotein NisI and ABC exporters

The *nisl* gene was recently identified in the middle of the nisin gene cluster and shown to be involved in the development of immunity. The deduced sequence of the 245-residue NisI suggests that it is a lipoprotein, probably anchored in the membrane with its C-terminus to the outer side of the cell (Kuipers *et al.*, 1993a). Cloning of *nisl* in a non-nisin producing *L. lactis* strain conferred a low level of immunity, which may be due to a low expression level since independent experiments showed that overexpression of *nisl* conferred a high level of immunity to *L. lactis* cells (Engelke *et al.*, 1994). Furthermore, overexpression of *nisl* under the control of the inducible T7-promoter in *E. coli* resulted in significant protection of EDTA-treated cells against exogenously added nisin (Kuipers *et al.*, 1993a). Finally, disruption of the *nisl* gene in nisin-producing *L. lactis* strains did not affect nisin production but considerably increased the sensitivity to nisin (Siegers and Entian, 1995; O. P. Kuipers *et al.*, unpublished results). Interestingly, the *spa* gene cluster contains a gene, *spaI*, for a 165-residue lipoprotein with no structural or sequence similarity to NisI, but also two other genes, *spaF* and *spaG*, that may encode an ABC exporter (Klein and Entian, 1994). Gene-disruption mutants in all these *spa* genes were more sensitive to subtilin than the wild-type strain, indicating that both the lipoprotein and the ABC exporter are involved in producer immunity. For microcin B17 it has been shown that an ABC exporter, consisting of McbF and McbE, is involved in translocation of microcin but also plays a role in the self-protection mechanism (del Carmen Garrido *et al.*, 1988). The SpaG and the N-terminal part of SpaF show significant homology with the McbG and McbF proteins, respectively, suggesting that a similar mechanism would operate in a

subtilin-producing *B. subtilis* (Klein and Entian, 1994). Very recently, downstream of the *nisABTCIPRK* cluster, three genes, designated *nisFEG*, were discovered (Siegers and Entian, 1995). The deduced sequences of NisF and NisE are highly similar to that of the N- and C-terminal parts of SpaF, respectively, while NisG is predicted to be a hydrophobic protein, like McbG. Mutations in all three *nisFEG* genes appeared to result in increased sensitivity to exogenously added nisin, indicating that next to the NisI lipoprotein an ABC exporter is also involved in self-protection in *L. lactis* (Siegers and Entian, 1995). These results imply that for the lantibiotics nisin and subtilin, which are extracellularly activated, NisT or SpaT would be involved in export of the precursor form, while the other ABC exporter (NisFEG or SpaFG) would translocate nisin or subtilin that has penetrated the membrane without being affected by the lipoproteins NisI or SpaI. Whether this second ABC exporter would also translocate precursor forms remains to be investigated but it would explain the subtilin-producing phenotype found for a SpaT disruption mutant (Klein *et al.*, 1992).

In lantibiotics that are completely intracellularly matured, another mechanism of immunity may be operating. One such a lantibiotic is Pep5, and it has been reported that expression of *pepI* that is located upstream from the structural gene *pepA* can confer immunity to Pep5 in *Staphylococcus epidermidis*, whereas disruption of this gene abolishes both Pep5 production and the immune phenotype (Reis *et al.*, 1994). Insensitive variants were only observed when both *pepA* and *pepI* were present in the constructed plasmid. This may indicate a role for a *pepA* gene product in immunity although a regulatory function cannot be excluded. The putative Pepl protein consists of only 69 amino acid residues, with a striking 20-amino-acid hydrophobic region between positions 6 and 27, suggesting a membrane location.

#### NisR/NisK and other two-component regulatory systems involved in the biosynthesis of lantibiotics

Preceding the *nisFEG* genes are the *nisR* and *nisK* genes, which encode a histidine kinase and response regulator, respectively (van der Meer *et al.*, 1993; Engelke *et al.*, 1994). A similar two-component system has been found in the *spa* gene cluster and the corresponding *spaRK* genes code for a proteins with significant homology to those encoded by the *nisRK* genes, (Klein *et al.*, 1993). In addition, the epidermin gene cluster contains the *epiQ* gene that also encodes a response regulator with only a little homology to NisR and SpaR (Augustin *et al.*, 1992). The most likely target for the response regulator is the promoter of the structural lantibiotic gene and for EpiQ such an interaction resulting in transcriptional activation has recently been confirmed (Peschel *et al.*, 1993). In view of

the differences in their transcriptional organization, it may be expected that variations on a similar theme can occur in the regulation of expression of the different lantibiotic gene clusters. It has been suggested that subtilin and nisin production is regulated (Klein *et al.*, 1993; Engelke *et al.*, 1994), and recently the inducing signal for nisin biosynthesis was found to be nisin itself (Kuipers *et al.*, submitted). The large similarity between the nisin and subtilin systems suggests that they may react to a similar stimulus.

### Maturation pathway of nisin

Taking together the results described above, we suggest the following maturation pathway for nisin (Fig. 4). In the first step (Step 1), the inducing signal activates, via the two-component signalling pathway, the *nisA* promoter, which has features also found in other positively regulated promoter sequences (de Vos and Simons, 1994). This results in production of the primary translation product of the *nisA* gene (pre-nisin) containing free cysteines and no dehydrated residues and which could adopt an  $\alpha$ -helical structure (Step 2). The pre-nisin is directed, presumably by virtue of the leader peptide, to a membrane-located complex containing the modifying enzymes NisB (possibly involved in dehydration) and NisC (conceivably involved in establishing the thioether bonds) (Step 3). At this stage, the leader may help to maintain the peptide in an inactive form (van der Meer *et al.*, 1993). Subsequently, the precursor nisin is translocated via the ABC exporter NisT at the expense of ATP hydrolysis (Step 4). Finally, precursor nisin is activated by proteolytic cleavage by the extracellular protease NisP that is hooked to the cell envelope by its fatty acyl membrane anchor (Step 5). The fate of the leader has not yet been determined and it remains to be established whether it is just degraded or has another function.

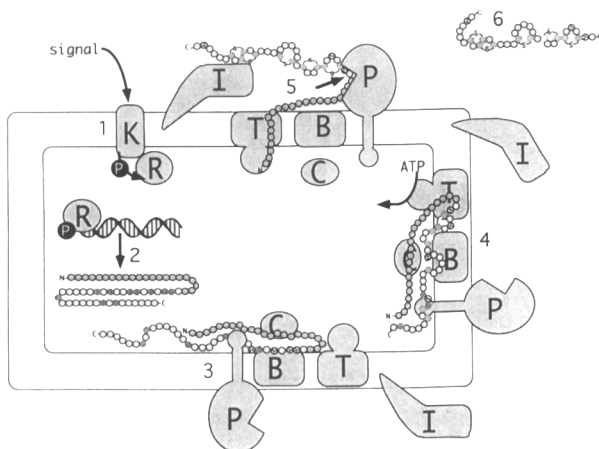

Fig. 4. Proposed maturation pathway of nisin (for an explanation, see the text).

The proposed sequence of the various maturation steps in time and space may also apply to other lantibiotics. However, additional intracellular conversions are required in the case of specific modification reactions such as those involving the N- and C-termini. It has recently been reported that the EpiD-catalysed C-terminal modification of epidermin may occur intracellularly as the first step in the post-translational modification of this lantibiotic (Kupke *et al.*, 1994). In addition, the presence of N-terminal modifications found in the lantibiotics Pep5 and epilancin K7 precludes export of a precursor form of those lantibiotics in which the leader is still attached to the N-terminus. This is in line with the observation that the proteases PepP and ElkP, which are encoded by the gene clusters for these related lantibiotics, do not contain a signal sequence, suggesting an intracellular location (Reis *et al.*, 1994; van de Kamp *et al.*, 1995). Similarly, an intracellular location may be predicted for the protease involved in cleaving the recently discovered lactocin S that also contains an N-terminally modified residue (Skaugen *et al.*, 1994). All these N-terminally modified lantibiotics would then require translocators that export the fully matured product which is not maintained in an inactive conformation by the presence of a leader sequence.

The exact nature of the individual reactions involved in the maturation pathway, e.g. the isolation and characterization of individual enzymes and other proteins, the *in vitro* conversion of serine and threonine residues present in propeptides into dehydrated residues, subsequent lantionine formation, and the elucidation of substrate requirements for these enzymes, awaits further investigation. Protein engineering of leader peptides and proregions of lantibiotics, recently initiated, appears to be an approach that promises to elucidate the substrate requirements (Kuipers *et al.*, 1992; Dodd *et al.*, 1992; Liu and Hansen, 1992; Kuipers *et al.*, 1993b; van der Meer *et al.*, 1994).

In conclusion, the maturation pathway we propose here for nisin shows that the role of the leader is still not fully understood, apart from its function in producing an inactive conformation. In particular, it is not known how it functions in targeting the pre-lantibiotic to the maturation and export proteins, what its fate is after cleavage, and in which way it may contribute to processes such as self protection after it has been cleaved off. This not only applies to the Class AI leaders but also to leaders that belong to Class AII. Both classes contain different conserved signature sequences that are probably recognized by the two different classes of modification enzymes. An important finding from the studies with nisin is that leader cleavage is not a prerequisite for export by the ABC exporter NisT and it is possible that this conclusion can be extended to other peptides with antimicrobial activity.

**Acknowledgements**

Part of this work was supported by contracts BIOT-CT-91-0263 and BIOT-CT-91-0265 of the European Union.

**References**

- Augustin, J., Rosenstein, R., Wieland, B., Schneider, U., Schnell, N., Engelke, G., Entian, K.-D., and Götz, F. (1992) *Eur J Biochem* **204**: 1149–1154.
- Baquero, F., and Moreno, F. (1984) *FEMS Microbiol Lett* **23**: 117–124.
- Bayer, A., Freund, S., Nicholson, G., and Jung, G. (1993) *Angew Chem Int Ed Engl* **32**: 1336–1339.
- Banerjee, S., and Hansen, J.N. (1988) *J Biol Chem* **263**: 9508–9514.
- Buchman, G.W., Banerjee, S., and Hansen, J.N. (1988) *J Biol Chem* **263**: 16260–16266.
- del Carmen Garrido, M., Herrero, M., Kolter, R., and Moreno, F. (1988) *EMBO J* **7**: 1853–1862.
- Chung, Y.J., and Hansen, J.N. (1992) *J Bacteriol* **174**: 6699–6702.
- Dodd, H.M., Horn, N., Hao, Z., and Gasson, M.J. (1992) *Appl Environ Microbiol* **58**: 3683–3693.
- Engelke, G., Gutowski-Eckel, Z., Hammelmann, M., and Entian, K.-D. (1992) *Appl Environ Microbiol* **58**: 3730–3743.
- Engelke, G., Gutowski-Eckel, Z., Kiesau, P., Siegers, K., Hammelmann, M., and Entian, K.-D. (1994) *Appl Environ Microbiol* **60**: 814–825.
- Fath, M.J., and Kolter, R. (1993) *Microbiol Rev* **57**: 995–1017.
- Fremaux, A., Muriana, P., and Klaenhammer, T.R. (1993) *Appl Environ Microbiol* **59**: 3906–3915.
- Gilmore, M.S., Segarra, R.A., and Booth, M.C. (1990) *Infect Immunol* **58**: 3914–3923.
- Gilmore, M.S., Segarra, R.A., Booth, M.C., Bogie, C.P., Hall, L.R., and Clewell, D.B. (1994) *J Bacteriol* **176**: 7335–7344.
- Gilson, L., Mahanty, H.K., and Kolter, R. (1990) *EMBO J* **9**: 3875–3884.
- Gross, E., and Morell, J.L. (1971) *J Am Chem Soc* **93**: 4634–4635.
- Gutowski-Eckel, Z., Klein, C., Siegers, K., Bohm, K., Hammelmann, M., and Entian, K.-D. (1994) *Appl Environ Microbiol* **60**: 1–11.
- Havarstein, L.S., Holo, H., and Nes, I.F. (1994) *Microbiol* **140**: 2383–2389.
- Holo, H., Nilsen, O., and Nes, I. (1991) *J Bacteriol* **173**: 3879–3887.
- Horn, N., Swindell, S., Dodd, H., and Gasson, M.J. (1991) *Mol Gen Genet* **228**: 129–135.
- Hynes, W.L., Ferretti, J.J., and Tagg, J.R. (1993) *Appl Environ Microbiol* **59**: 1969–1971.
- Hynes, W.L., Ferretti, J.J., and Tagg, J.R. (1994) *Appl Environ Microbiol* **60**: 4207–4209.
- Immonen, T., Ye, S., Ra, R., Qiao, M., Paulin, L., and Saris, P.E.J. (1995) *DNA Sequence* **5**: 203–218.
- Ingram, L. (1970) *Biochem Biophys Acta* **224**: 263–265.
- Jung, G. (1991) in *Nisin and Novel Lantibiotics: Proceedings of the First International Workshop on Lantibiotics*. Jung, G., and Sahl, H.-G. (eds). Leiden: Escom Publishers, pp. 1–25.
- Kaletta, C., and Entian, K.-D. (1989) *J Bacteriol* **171**: 1597–1601.
- Kaletta, C., Entian, K.-D., Kellner, R., Jung, G., Reis, M., and Sahl, H.-G. (1989) *Arch Microbiol* **152**: 16–19.
- van de Kamp, M., van den Hooven, H.W., Konings, R.N.H., Hilbers, C.W., van de Ven, F.J.M., Bierbaum, G., Sahl, H.-G., Kuipers, O.P., Siezen, R.J., and de Vos, W.M. (1995) *Eur J Biochem* **230**: 587–600.
- Kellner, R., Jung, G., Josten, M., Kaletta, C., Entian, K.-D., and Sahl, H.-G. (1989) *Angew Chem Int Ed Engl* **28**: 616–619.
- Klaenhammer, T.R. (1993) *FEMS Microbiol Rev* **12**: 39–87.
- Klein, C., and Entian, K.-D. (1994) *Appl Environ Microbiol* **60**: 2793–2801.
- Klein, C., Kaletta, C., Schnell, N., and Entian, K.-D. (1992) *Appl Environ Microbiol* **58**: 132–142.
- Klein, C., Kaletta, C., and Entian, K.-D. (1993) *Appl Environ Microbiol* **59**: 296–303.
- Kolter, R., and Moreno, F. (1992) *Annu Rev Microbiol* **46**: 141–163.
- Kuipers, O.P., Rollema, H.S., Yap, W.M.G.J., Boot, H.J., Siezen, R.J., and de Vos, W.M. (1992) *J Biol Chem* **267**: 24340–24346.
- Kuipers, O.P., Beerthuyzen, M.M., Siezen, R.J., and de Vos, W.M. (1993a) *Eur J Biochem* **216**: 281–291.
- Kuipers, O.P., Rollema, H.S., de Vos, W.M., and Siezen, R.J. (1993b) *FEBS Lett* **330**: 23–27.
- Kupke, T., Stefanović, S., Sahl, H.-G., and Götz, F. (1992) *J Bacteriol* **174**: 5354–5361.
- Kupke, T., Kempter, C., Gnau, V., Jung, G., and Götz, F. (1994) *J Biol Chem* **269**: 5653–5659.
- Liu, W., and Hansen, J.N. (1992) *J Biol Chem* **267**: 25078–25085.
- Marugg, J.D., Gonzalez, C.F., Kunka, B.S., Ledebauer, A.M., Pucci, M.J., Toonen, M.Y., Walker, S.A., Zoetmulder, L.C.M., and Vandeborgh, P.A. (1992) *Appl Environ Microbiol* **58**: 2360–2367.
- Mattick, A.T.R., and Hirsch, A. (1944) *Nature* **154**: 551.
- van der Meer, J.R., Polman, J., Beerthuyzen, M.M., Siezen, R.J., Kuipers, O.P., and de Vos, W.M. (1993) *J Bacteriol* **175**: 2578–2588.
- van der Meer, J.R., Rollema, H.S., Siezen, R.J., Beerthuyzen, M.M., Kuipers, O.P., and de Vos, W.M. (1994) *J Biol Chem* **269**: 3555–3562.
- Muldres, J.W.M., Boerrigter, I.J., Rollema, H.S., Siezen, R.J., and de Vos, W.M. (1991) *Eur J Biochem* **201**: 581–584.
- Peschel, A., Augustin, J., Kupke, T., Stefanović, S., and Götz, F. (1993) *Mol Microbiol* **9**: 31–39.
- Piard, J.-C., Kuipers, O.P., Rollema, H.S., Desmazeaud, M.J., and de Vos, W.M. (1993) *J Biol Chem* **268**: 16361–16368.
- Rauch, P.J.G., and de Vos, W.M. (1992) *J Bacteriol* **174**: 1280–1287.
- Rauch, P.J.G., Beerthuyzen, M.M., and de Vos, W.M. (1994) *Appl Environ Microbiol* **60**: 1798–1804.
- Reis, M., Eschbach-Bludau, M., Iglesias-Wind, M.I., Kupke, T., and Sahl, H.-G. (1994) *Appl Environ Microbiol* **60**: 2876–2883.
- Rince, A., Dufour, A., Le Pogam, S., Thuault, D., Bourgeois, C.M., and LePenne, J.P. (1994) *Appl Environ Microbiol* **60**: 1652–1657.

- Ross, K.F., Ronson, C.W., and Tagg, J.R. (1993) *Appl Environ Microbiol* **59**: 2014–2021.
- Sahl, H.-G. (1991) In *Nisin and Novel Lantibiotics: Proceedings of the First International Workshop on Lantibiotics*. Jung, G., and Sahl, H.-G. (eds). Leiden: Escom Publishers, pp. 347–359.
- Sahl, H.-G., Jack, R.W., and Bierbaum, G. (1995) *Eur J Biochem* **230**: 827–853.
- Schnell, N. (1989) PhD Thesis, University of Frankfurt, Frankfurt, Germany.
- Schnell, N., Entian, K.-D., Schneider, U., Götz, F., Zähler, H., Kellner, R., and Jung, G. (1988) *Nature* **333**: 276–278.
- Schnell, N., Entian, K.-D., Götz, F., Hörner, T., Kellner, R., and Jung, G. (1989) *FEMS Microbiol Lett* **58**: 263–268.
- Schnell, N., Engelke, G., Augustin, J., Rosenstein, R., Ungermann, V., Götz, F., and Entian, K.-D. (1992) *Eur J Biochem* **204**: 57–68.
- Siegers, K., and Entian, K.-D. (1995) *Appl Environ Microbiol* **61**: 1082–1089.
- Siezen, R.J., Kuipers, O.P., and de Vos, W.M. (1995) *Ant v Leeuwenhoek*, in press.
- Siezen, R.J., Rollema, H.S., Kuipers, O.P., and de Vos, W.M. (1995) *Prot Eng* **8**: 117–125.
- Skaugen, M., Nissen-Meyer, J., Jung, G., Stevanović, S., Sletten, K., Mortvedt-Abilgaard, C.I., and Nes, I.F. (1994) *J Biol Chem* **269**: 27183–27185.
- Stoddard, G.W., Petzel, J.P., van Belkum, M.J., Kok, J., and McKay, L.L. (1992) *Appl Environ Microbiol* **58**: 1952–1961.
- Tagg, J.R., Dajani, A.S., and Wannamaker, L.W. (1976) *Microbiol Rev* **40**: 722–756.
- Toogood, P.L. (1993) *Tetrahedron Lett* **34**: 7833–7836.
- van de Ven, F.J.M., van den Hooven, H.W., Konings, R.N.H., and Hilbers, C.W. (1991) *Eur J Biochem* **202**: 1181–1188.
- de Vos, W.M. (1993) In *Bacteriocins of Lactic Acid Bacteria*. Hoover, D.G., and Steenson, L.R. (eds). San Diego: Academic Press, pp. 249–265.
- de Vos, W.M., and Simons, G.F.M. (1994) In *Genetics and Biotechnology of Lactic Acid Bacteria*. Gasson, M.J., and de Vos, W.M. (eds). Glasgow: Blackie Academic and Professional, pp. 52–105.
- de Vos, W.M., Jung, G., and Sahl, H.-G. (1991) In *Nisin and Novel Lantibiotics: Proceedings of the First International Workshop on Lantibiotics*. Jung, G., and Sahl, H.-G. (eds). Leiden: Escom Publishers, pp. 457–464.
- de Vos, W.M., Mulders, J.W.M., Hugenholtz, J., Siezen, R.J., and Kuipers, O.P. (1993) *Appl Environ Microbiol* **59**: 213–218.
- de Vos, W.M., Beerthuyzen, M.M., Luesink, E.J., and Kuipers, O.P. (1995) In *Genetics of Streptococci, Enterococci and Lactococci. Dev Biol Stand Vol. 85*. Ferretti, J.J., Gilmore, M.S., Klaenhammer, T.R., and Brown, F. (eds). Basel: Karger, pp. 617–625.
- Weil, H.-P., Beck-Sickinger, A.G., Metzger, J., Stevanović, S., Jung, G., Josten, M., and Sahl, H.-G. (1990) *Eur J Biochem* **194**: 217–223.
- Yorgey, P., Davagnino, J., and Kolter, R. (1993) *Mol Microbiol* **9**: 897–905.