

University of Groningen

## Pulse compression below 5 fs at MHz repetition rate

Baltuška, Andrius; Pshenichnikov, Maxim S.; Wiersma, Douwe A.; Szipöcs, Róbert

*Published in:*

Technical Digest. Summaries of papers presented at the Conference on Lasers and Electro-Optics, 1998. CLEO 98

**IMPORTANT NOTE: You are advised to consult the publisher's version (publisher's PDF) if you wish to cite from it. Please check the document version below.**

*Document Version*

Publisher's PDF, also known as Version of record

*Publication date:*

1998

[Link to publication in University of Groningen/UMCG research database](#)

*Citation for published version (APA):*

Baltuška, A., Pshenichnikov, M. S., Wiersma, D. A., & Szipöcs, R. (1998). Pulse compression below 5 fs at MHz repetition rate: current status, prospects, and applications. In *Technical Digest. Summaries of papers presented at the Conference on Lasers and Electro-Optics, 1998. CLEO 98* (pp. 365-366). University of Groningen, The Zernike Institute for Advanced Materials.

### Copyright

Other than for strictly personal use, it is not permitted to download or to forward/distribute the text or part of it without the consent of the author(s) and/or copyright holder(s), unless the work is under an open content license (like Creative Commons).

The publication may also be distributed here under the terms of Article 25fa of the Dutch Copyright Act, indicated by the "Taverne" license. More information can be found on the University of Groningen website: <https://www.rug.nl/library/open-access/self-archiving-pure/taverne-amendment>.

### Take-down policy

If you believe that this document breaches copyright please contact us providing details, and we will remove access to the work immediately and investigate your claim.

*Downloaded from the University of Groningen/UMCG research database (Pure): <http://www.rug.nl/research/portal>. For technical reasons the number of authors shown on this cover page is limited to 10 maximum.*

kHz<sup>1,2</sup> and 200 nJ at a repetition rate of 1 kHz with pulse duration as short as 13 fs has been directly generated from laser cavities.<sup>3</sup> Investigators have also examined techniques to design standard repetition rate KLM lasers to operate at high powers and achieve high-intensity pulses.<sup>4</sup>

In this paper, we present a simple alternative method for improving peak power from a laser by designing a novel long-cavity geometry for KLM. This represents a complementary concept to scaling laser designs to shorter cavity lengths and compact sizes to achieve high repetition rates. In this case, the objective is to increase laser output pulse energies and intensities by increasing cavity lengths. Because the total output power of the laser cannot be increased, the pulse energy can be increased by reducing the laser repetition rate. The development of long-cavity lasers requires careful design, because the operation KLM depends critically on laser-cavity design. The laser cavity must be operated in a particular subset of its stability region and to optimize mode-locking performance.

As an approach to developing long-cavity lasers, we explored the use of Herriott-style MPC.<sup>5</sup> This device has been used for spectroscopy of gases where long optical propagation paths in a gas cell are required.<sup>6</sup> The MPC is constructed with a pair of curved mirrors separated by a given distance. The mirrors have notches cut in them to introduce and extract the optical beam. The optical beam is introduced into the MPC so that it strikes the first mirror off center and subsequently bounces between the two mirrors in a circular pattern, where it can be extracted after a given number of passes. The beam is also focused on subsequent bounces so that its propagation resembles propagation through a periodic lens array. This device is designed so that it provides a unity transformation of the *q* parameter of the laser beam after a given number of transits. Thus, if this device is inserted into the KLM laser, it can be designed so that it has zero effective length and leaves the laser cavity mode and nonlinear focusing behavior invariant.

The laser consists of a standard, dispersion-compensated KLM Ti:Al<sub>2</sub>O<sub>3</sub> with MPC incor-

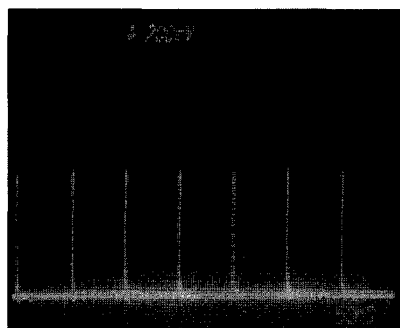

CTHJ6 Fig. 2. Mode-locked laser pulse train of 15-MHz repetition rate or 68-ns pulse separation at 50 ns/div.

porated into one of the arms (Fig. 1). Mode locking was achieved at 15 MHz repetition rate, where the MPC has two mirrors M1 and M2 separated by 82.4 cm and the beam made 20 round-trip passes between the mirrors (Fig. 2). At 3.5 W pump power, we obtained 140 mW average output power and 20-fs nearly-transform-limited pulse duration centered at 807 nm (Fig. 3). This implies a peak power of  $\approx 0.5$  MW. Furthermore, because the pulse repetition rates are significantly lower, parasitic effects in ultrafast measurements using this source will be significantly less than for conventional high-repetition-rate 100-MHz lasers.

One limitation to the available pulse energies in our system was imposed by multiple-pulse instabilities that tend to arise at high pulse energies. This is a consequence of the high peak intensities present in this laser and the saturation of the self-amplitude modulation effects produced in KLM. Achieving high pulse energies requires a detailed understanding of the KLM mechanism and cavity operation because, as the laser cavity length is increased, the intracavity pulse energies and intensities are also increased to higher levels than in standard lasers. We are currently optimizing the pulse duration and output power performance to avoid multiple pulsing and to stably obtain a several-MW pulse peak power. In future work, the design and operating point

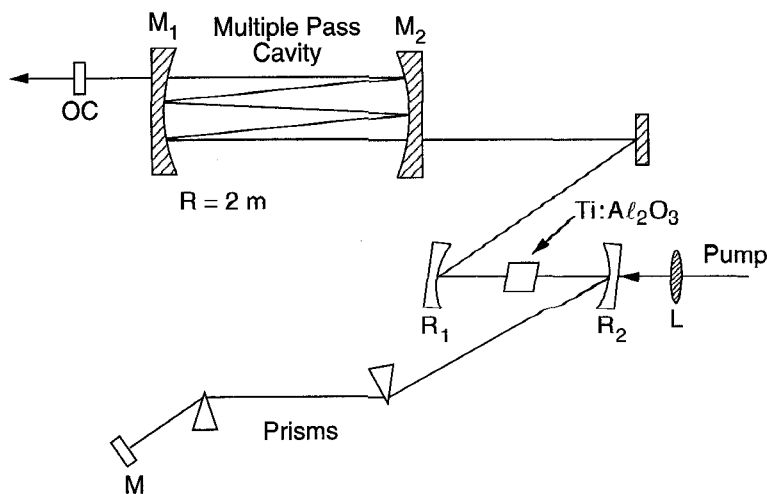

CTHJ6 Fig. 1. Ti:Al<sub>2</sub>O<sub>3</sub> laser schematic with a pair of multiple-pass cavity mirrors.

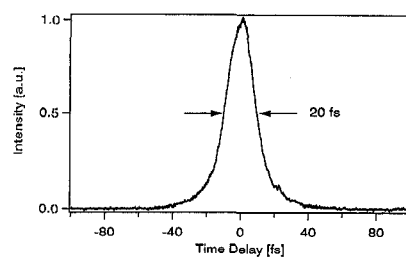

(a)

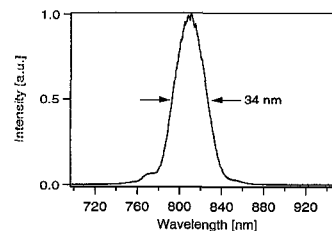

(b)

CTHJ6 Fig. 3. Intensity autocorrelation trace (a) and associated spectrum of 20 fs duration (b) from a KLM Ti:Al<sub>2</sub>O<sub>3</sub> laser pulse.

of the laser will be extended to <10 MHz repetition rate.

In conclusion, mode-locked operation at 15 MHz has been demonstrated using a novel and long-cavity laser with an MPC. We successfully obtained 0.5 MW peak power and 20 fs nearly-transform-limited pulse from KLM Ti:Al<sub>2</sub>O<sub>3</sub> laser. This unprecedented low repetition rate laser suggests new approaches for achieving MW-level peak powers from laser cavities.

We thank Igor Bilinsky for scientific assistance. We would like to thank CVI Incorporated for help in designing the mirrors used in this study.

\*Present address: Wellman Laboratory, Massachusetts General Hospital

1. M. Ramaswamy, M. Ulman, J. Paye, J.G. Fujimoto, *Opt. Lett.* **18**, 1822 (1993).
2. M.S. Pshenichnikov, W.P. de Boeij, D.A. Wiersma, *Opt. Lett.* **19**, 572 (1994).
3. G.N. Gibson, R. Klank, G. Gibson, B.E. Bouma, *Opt. Lett.* **21**, 1055 (1996).
4. L. Xu, G. Tempea, A. Poppe, M. Lenzner, C. Spielmann, F. Krausz, A. Stingl, K. Ferencz, *Appl. Phys. B* **65**, 151 (1997).
5. D. Herriott, H. Kogelnik, R. Kompfner, *Appl. Opt.* **3**, 523 (1964).
6. W.R. Trutna, R.L. Byer, *Appl. Opt.* **19**, 301 (1980).

CTHJ7 12:15 pm

**Pulse compression below 5 fs at MHz repetition rate: current status, prospects, and applications**

Andrius Baltuška, Maxim S. Pshenichnikov, Douwe A. Wiersma, Róbert Szipöcs,\*  
*Ultrafast Laser and Spectroscopy Laboratory, Department of Chemistry, University of Groningen, Nijenborgh 4, 9747 AG Groningen, The Netherlands*

The basic recipe to generate ultrashort pulses consists of four main ingredients: (i) generation of white-light continuum (WLC) with

Thursday, May 7

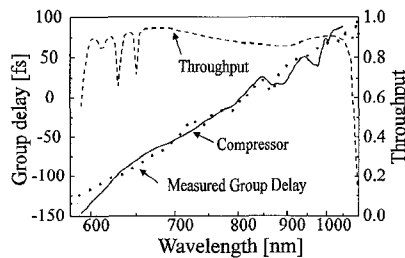

**CThJ7** Fig. 1. The measured group delay of the white-light continuum as derived from SHG FROG measurements (dots), the group delay (solid line), and throughput (dashed line) of the three-stage compressor.

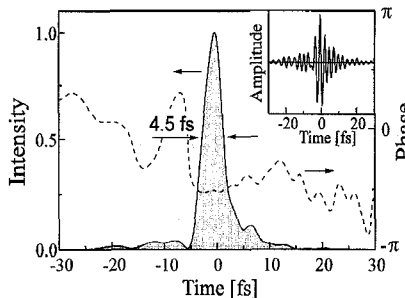

**CThJ7** Fig. 2. The intensity profile (solid line) and the phase (dashed line) of the compressed 4.5-fs pulse retrieved via SHG FROG. The real part of the electric field is shown in the inset.

sufficient spectral bandwidth, (ii) measurement of the spectral phase of the resulting WLC, (iii) design of a compressor suitable for phase correction over the whole continuum bandwidth, and (iv) determination of the compressed pulse duration and its phase. In our setup, the required ultrabroad bandwidth of WLC is produced on injection of  $\sim 13$ -fs, 35-n pulses from a Millennia-pumped cavity-dumped Ti:sapphire laser into a single-mode fused silica fiber.<sup>1</sup> Due to self-phase-modulation (SPM) in the fiber, the exiting pulse has a spectrum stretching from 500 nm to  $\sim 1.1$   $\mu\text{m}$ . Combined action of SPM and dispersion leads to a nearly linear group delay (Fig. 1, dotted line) over most of the spectrum, as was resolved by means of second-harmonic generation frequency-resolved optical gating (SHG FROG).<sup>2</sup>

Group delay measurements of the generated continuum served as a target function for the design of the three-stage, high-throughput compressor, consisting of a quartz  $45^\circ$ -prism pair, broadband chirped mirrors, and thin-film Gires-Tournois dielectric interferometers. The phase characteristics of the compressor were analyzed using dispersive ray tracing and mapped onto the measured group delay of the continuum (Fig. 1, solid line).

To retrieve the temporal phase and shape of the compressed pulse, we employed the SHG FROG. The results of processing of the experimental FROG traces by the commercially available FROG program (Femtosec Technologies) are shown in Fig. 2. The compressed pulse duration is  $\sim 4.5$  fs, which corresponds to  $\sim 2.5$  oscillation of the electric field at its FWHM. Excursion of phase across most of the

spectrum does not exceed  $\sim \pi/4$  and originates from the nonsmooth phase of employed chirped mirrors.

Having succeeded previously in compressing the white light pulse below 6 fs by using exclusively chirped mirrors with reflectivity  $>98\%$  in the range 550–1080 nm, our current work is aimed at substantial improvement of their dispersive properties. The synthesis of such mirror structures is based on a novel computation technique<sup>3</sup> particularly developed for chirped mirrors. A new and more robust numerical engine for mirror design permitted a significant reduction in computation time and flexibility is desired dispersion properties.

We also foresee utilization of programmable phase masks<sup>4</sup> for compensation of residual phase distortion remaining after the pulse compressor. Additionally, by applying such pulse-shaping techniques, variably delayed replicas of the pulse needed in numerous nonlinear optical experiments could be generated without optical beam splitting and recombining in an interferometrically stable setup.

Our white-light-producing setup also offers great versatility meeting demands of different spectroscopic applications. By using a wavelength-selective element, the laser is converted into a continuously tunable source of longer pulses (20–30 fs) over the entire spectral bandwidth of white light.

The sub-5-fs pulses are used in nonlinear optical experiments to study ultrafast chemical reaction dynamics in solutions. The high repetition rate, simplicity, and large spectral bandwidth ( $>500$  nm) make this light source ideal for spectroscopic applications in condensed phase.

\*Research Institute for Solid State Physics, P.O. Box 49, H-1525 Budapest, Hungary

1. A. Baltuška, Z. Wei, M.S. Pshenichnikov, D.A. Wiersma, *Opt. Lett.* **22**, 102 (1997).
2. G. Taft, A. Rundquist, M. Murnane, I. Christov, H. Kapteyn, K. DeLong, D. Fittinghoff, M. Krumbugel, J. Sweetser, R. Trebino, *IEEE J. Select. Top. Quantum Electron.* **2**, 575 (1996).
3. R. Szpöcs, A. Kohazi-Kis, *Appl. Phys. B* **65**, 115 (1997).
4. A.M. Weiner, J.P. Heritage, E.M. Kirschner, *J. Opt. Soc. Am. B* **5**, 1563 (1988).

**CThK**

**10:30 am–12:30 pm**

Room 103

**VCSEL Applications**

Kent D. Choquette, *Sandia National Laboratories, President*

**CThK1 (Invited)**

**10:30 am**

**High-performance multiple-wavelength vertical-cavity photonic-integrated-emitter arrays for direct-coupled multimode optical links**

S.Y. Hu, J. Ko, E.R. Hegblom, L.A. Coldren, *Department of Electrical and Computer Engineering, University of California, Santa Barbara, California 93106*

For short-haul wavelength-division multiplexing (WDM) applications, it is desirable to have a compact, individually addressable, multiple-wavelength emitter array to bring many channels of information directly into a multimode fiber without resorting to complicated coupling optics. The simplicity in packaging of this butt-coupled (for top emitters) or Burrus-coupled<sup>1</sup> (for bottom emitters) configuration implies that it will be highly manufacturable and with a much lower cost. In this talk, we demonstrate high-performance multiple-wavelength photonic-integrated-emitter (PIE) vertical-cavity surface-emitting laser (VCSEL) arrays and their optical links with wavelength-selective photodetector arrays<sup>2</sup> for such direct-coupled WDM systems.

Our VCSEL PIE array consists of eight pie-shaped bottom-emitting VCSELs arranged within a 60- $\mu\text{m}$ -diameter area to match the core of a multimode fiber. We used the 0.98- $\mu\text{m}$  VCSEL design with InGaAs quantum wells and AlGaAs/GaAs mirrors. Cavity modes for the individual channels were adjusted by performing a three-level binary-coding anodic oxidation<sup>2</sup> on the GaAs phase-tuning layer before the growth of the rest of the top mirror.<sup>3</sup> A manufacturable planar processing technique was developed to facilitate further packaging of these VCSEL PIE arrays. The idea is to etch deep, narrow trenches to define these pie-shaped VCSELs, followed by a shallow wet oxidation extending only 1.0  $\mu\text{m}$  from the edges. Those trenches were then filled up with polyimide for  $p$ -metal crossover. Figure 1 shows a

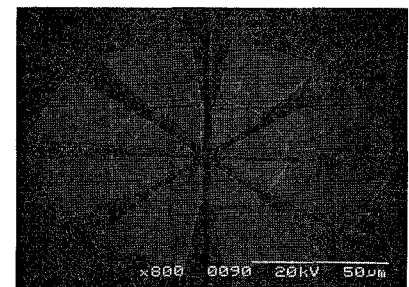

**CThK1** Fig. 1. Scanning electron micrograph of a finished bottom-emitting VCSEL PIE array.