

University of Groningen

A Novel Passivity Property of Nonlinear RLC Circuits

Jeltsema, D.; Ortega, R.; Scherpen, J.M.A.

Published in:

Proceedings of the 4th Mathmod Symposium, ARGESIM Report 24

IMPORTANT NOTE: You are advised to consult the publisher's version (publisher's PDF) if you wish to cite from it. Please check the document version below.

Document Version

Publisher's PDF, also known as Version of record

Publication date:

2003

[Link to publication in University of Groningen/UMCG research database](#)

Citation for published version (APA):

Jeltsema, D., Ortega, R., & Scherpen, J. M. A. (2003). A Novel Passivity Property of Nonlinear RLC Circuits. In *Proceedings of the 4th Mathmod Symposium, ARGESIM Report 24* (pp. 845-853). University of Groningen, Research Institute of Technology and Management.

Copyright

Other than for strictly personal use, it is not permitted to download or to forward/distribute the text or part of it without the consent of the author(s) and/or copyright holder(s), unless the work is under an open content license (like Creative Commons).

The publication may also be distributed here under the terms of Article 25fa of the Dutch Copyright Act, indicated by the "Taverne" license. More information can be found on the University of Groningen website: <https://www.rug.nl/library/open-access/self-archiving-pure/taverne-amendment>.

Take-down policy

If you believe that this document breaches copyright please contact us providing details, and we will remove access to the work immediately and investigate your claim.

Downloaded from the University of Groningen/UMCG research database (Pure): <http://www.rug.nl/research/portal>. For technical reasons the number of authors shown on this cover page is limited to 10 maximum.

Please refer to this paper as:

D. Jeltsema, R. Ortega, J.M.A. Scherpen, "A novel passivity property of nonlinear RLC circuits", Proc. 4th Mathmod Symposium, ARGESIM Report 24, Vienna, February 2003, 845-853.

A NOVEL PASSIVITY PROPERTY OF NONLINEAR RLC CIRCUITS*

D. Jeltsema[‡], R. Ortega[§] and J.M.A. Scherpen[‡]

Corresponding author: D. Jeltsema

[‡]Control Systems Eng. Group
Delft University of Technology
P.O. Box 5031, 2600 GA Delft
The Netherlands

[§]Lab. des Signaux et Systèmes
Supelec, Plateau du Moulon
91192 Gif-sur-Yvette
France

Phone: +33-(0)15-278-5489, Fax: +31-(0)15-278-6679

Email: d.jeltsema@its.tudelft.nl

Abstract. Arbitrary interconnections of passive (possibly nonlinear) resistors, inductors and capacitors define passive systems, with port variables the external sources voltages and currents, and storage function the total stored energy. In this paper we identify a class of RLC circuits (with convex energy function and weak electromagnetic coupling) for which it is possible to ‘add a differentiation’ to the port terminals preserving passivity—with a new storage function that is directly related to the circuit power. To establish our results we exploit the geometric property that voltages and currents in RLC circuits live in orthogonal spaces, i.e., Tellegen’s theorem, and heavily rely on the seminal paper of Brayton and Moser published in the early sixties.

1. Introduction

Passivity is a fundamental property of dynamical systems that constitutes a cornerstone for many major developments in circuit and systems theory, see e.g. [6] and the references therein. It is well-known that (possibly nonlinear) RLC circuits consisting of arbitrary interconnections of passive resistors, inductors, capacitors and voltage and/or current sources are also passive with port variables the external source voltages and currents, and storage function the total stored energy [2]. Our main contribution in this paper is the proof that for all RL or RC circuits, and a class of RLC circuits it is possible to ‘add a differentiation’ to one of the port variables (either voltage or current) preserving passivity with a storage function which is directly related to the circuit power. The new passivity property is of interest in circuit theory, but also has applications in control (see [4] for some first results regarding stabilization).

Since the supply rate (the product of the passive port variables) of the standard passivity property is voltage \times current, it is widely known that the differential form of this passivity in-

*This project was partially supported by the European Community Marie Curie Fellowship in the framework of the CTS (Control Training Site).

equality establishes the *active* power-balance of the circuit. As the new supply rate is voltage \times the time-derivative of the current (or current \times the time-derivative of the voltage)—quantities which are sometimes adopted as suitable definitions of the supplied *reactive* power—our result unveils some sort of reactive power-balance.

The remaining of the paper is organized as follows. In Section 2 we briefly review some fundamental results in circuits theory, like the classical definition of passivity and Tellegen’s Theorem. The new passivity property for RL and RC is established in Section 3. In Section 4 this result is extended to a class of RLC circuits using the classical Brayton-Moser equations. Finally, we conclude the paper with some remarks and comments on future research.

2. Tellegen’s Theorem and Passivity

Consider a circuit consisting of n_L inductors, n_C capacitors, n_R resistors and n_S voltage and/or current sources, called the *branches* of the circuit. Let $i_\gamma = \text{col}(i_{\gamma_1}, \dots, i_{\gamma_{n_\gamma}}) \in \mathbb{R}^{n_\gamma}$ and $v_\gamma = \text{col}(v_{\gamma_1}, \dots, v_{\gamma_{n_\gamma}}) \in \mathbb{R}^{n_\gamma}$, with $\gamma = \{L, C, R, S\}$, denote the branch currents and voltages of the circuit, respectively. It is well-known that Tellegen’s theorem [5] states that the set of branch currents (which satisfy Kirchhoff’s current law), say $\mathbb{K}_i \subset \mathbb{R}^b$, $b = \sum_\gamma n_\gamma$, and the set of branch voltages (that satisfy Kirchhoff’s voltage law), say $\mathbb{K}_v \subset \mathbb{R}^b$, are orthogonal subspaces. As an immediate consequence of this fact we have

$$\sum_\gamma i_\gamma^\top v_\gamma = 0, \quad (1)$$

which states that the total power in the circuit is preserved.

Corollary 1 *Voltages and currents in a (possibly nonlinear) RLC circuit satisfy*

$$\sum_\gamma v_\gamma^\top \frac{di_\gamma}{dt} = 0, \quad (2)$$

as well as

$$\sum_\gamma i_\gamma^\top \frac{dv_\gamma}{dt} = 0. \quad (3)$$

The proof of this corollary is easily established noting that, if $i_\gamma \in \mathbb{K}_i$ (resp. $v_\gamma \in \mathbb{K}_v$), then clearly also $\frac{di_\gamma}{dt} \in \mathbb{K}_i$ (resp. $\frac{dv_\gamma}{dt} \in \mathbb{K}_v$), and then invoking orthogonality of \mathbb{K}_i and \mathbb{K}_v .

Another immediate consequence of Tellegen’s theorem is the following, slight variation of the classical result in circuit theory, see, e.g., Section 19.3.3 of [2], whose proof is provided for the sake of completeness.

Proposition 1 *Arbitrary interconnections of inductors and capacitors with passive resistors verify the energy-balance inequality*

$$\int_0^t i_S^\top(t') v_S(t') dt' \geq E[\varphi_L(t), q_C(t)] - E[\varphi_L(0), q_C(0)], \quad (4)$$

where we have defined the total stored energy $E(\varphi_L, q_C) = E_L(\varphi_L) + E_C(q_C)$ with $\varphi_L \in \mathbb{R}^{n_L}$ and $q_C \in \mathbb{R}^{n_C}$ the inductor fluxes and the capacitor charges, respectively. If, furthermore, the inductors and capacitors are also passive, then the network defines a passive system with port variables $i_S, v_S \in \mathbb{R}^{n_S}$ and storage function the total energy.

Proof: First, notice that $\frac{dE}{dt} = i_L^\top v_L + i_C^\top v_C$, where we have used the fact that $i_L = \nabla_{\varphi_L} E_L(\varphi_L)$ and $v_C = \nabla_{q_C} E_C(q_C)$, with $\nabla_{(\cdot)} = \frac{\partial}{\partial(\cdot)}$ denoting the partial derivative, and the constitutive relations $v_L = \frac{d\varphi_L}{dt}$ and $i_C = \frac{dq_C}{dt}$. Then, by (1) we have that $i_L^\top v_L + i_C^\top v_C = i_S^\top v_S - i_R^\top v_R$ (notice that we have adopted the standard sign convention for the supplied power). Hence, noting that $i_R^\top v_R \geq 0$ for passive resistors, and integrating the latter equations from 0 to t , we obtain (4). Passivity follows from positivity of $E(\varphi_L, q_C)$ for passive inductors and capacitors. ■

3. A New Passivity Property for RL and RC Circuits

In this section we first consider circuits consisting solely of inductors and current-controlled resistors and sources, denoted by Σ_L , and circuits consisting solely of capacitors and voltage-controlled resistors and sources, denoted by Σ_C . Furthermore, to present the new passivity property we need to define some additional concepts that are well-known in circuit theory [3, 5], and will be instrumental to formulate our results.

Definition 1 The content of a current-controlled resistor is defined as

$$F_k(i_{R_k}) = \int_0^{i_{R_k}} \hat{v}_{R_k}(i'_{R_k}) di'_{R_k}, \quad (5)$$

while for a voltage-controlled resistor the function

$$G_k(v_{R_k}) = \int_0^{v_{R_k}} \hat{i}_{R_k}(v'_{R_k}) dv'_{R_k} \quad (6)$$

is called the resistors co-content.

Proposition 2 Arbitrary interconnections of passive inductors with convex energy function $E_L(\varphi_L)$, current-controlled resistors and sources, satisfy the power-balance inequality

$$\int_0^t v_S^\top(t') \frac{di_S}{dt'}(t') dt' \geq F[i_R(t)] - F[i_R(0)], \quad (7)$$

where $F(i_R) = \sum_{k=1}^{n_R} F_k(i_{R_k})$. If the resistors are passive, the circuit Σ_L defines a passive system with port variables $(v_S, \frac{di_S}{dt})$ and storage function the total resistors content.

Similarly, arbitrary interconnections of passive capacitors with convex energy function $E_C(q_C)$, voltage-controlled resistors and sources, satisfy the power-balance inequality

$$\int_0^t i_S^\top(t') \frac{dv_S}{dt'}(t') dt' \geq G[v_R(t)] - G[v_R(0)], \quad (8)$$

where $G(v_R) = \sum_{k=1}^{n_R} G_k(v_{R_k})$. If the resistors are passive, the circuit Σ_C defines a passive system with port variables $(i_S, \frac{dv_S}{dt})$ and storage function the total resistors co-content.

Proof: The proof of the new passivity property for RL circuits is established as follows. First, differentiate the resistors content

$$\frac{dF}{dt}(i_R) = v_R^\top \frac{di_R}{dt}. \quad (9)$$

Then, from the fact that $\frac{di_L}{dt} = \nabla_{\varphi_L}^2 E_L(\varphi_L) v_L$ we notice that

$$v_L^\top \frac{di_L}{dt} = v_L^\top \nabla_{\varphi_L}^2 E_L(\varphi_L) v_L \geq 0, \quad (10)$$

where the non-negativity stems from the convexity assumption. Finally, by substituting (9) and (10) into (2) of Corollary 1, with $v_C = 0$ and $i_C = 0$, and integrating from 0 to t yields the result.

The proof for RC circuits follows verbatim, but now using (3) of Corollary 1 instead of (2), the relation $\frac{dv_C}{dt} = \nabla_{q_C}^2 E_C(q_C) i_C$ and the definition of the co-content. ■

Remark 1 In some cases it is possible to include also voltage-controlled resistors in Σ_L (resp. current-controlled resistor in Σ_C) under the condition that the (i_R, v_R) curves are invertible.

Remark 2 The new passivity properties of Proposition 2 differ from the standard result of Proposition 1 in the following respects. First, while Proposition 1 holds for general RLC circuits, the new properties are valid only for RC or RL systems. Using the fact that passivity is invariant with respect to negative feedback interconnections it is, of course, possible to combine RL and RC circuits and establish passivity of some RLC circuits. A class of RLC for which a similar property holds will be identified in Section 4. Second, the condition of convexity of the energy functions required for Proposition 2 is sufficient, but not necessary for passivity of the dynamic elements. Hence, the class of admissible dynamic elements is more restrictive.

Remark 3 It is interesting to remark that the supply rate of the new passive systems defined by either the product $v_S^\top \frac{di_S}{dt}$ or $i_S^\top \frac{dv_S}{dt}$, coincides with a commonly accepted definition of *reactive power*.

4. Passivity of Brayton-Moser Circuits

The previous developments show that, using the content and co-content as storage functions and the reactive power as supply rate, we can identify new passivity properties of RL and RC circuits. In this section we will establish similar properties for RLC circuits. Towards this end, we strongly rely on some fundamental results reported in [1]. Furthermore, we assume that the current-controlled resistors, denoted by R_L , are contained in Σ_L and the voltage-controlled resistors, denoted by R_C , are contained in Σ_C . The class of RLC circuits considered here is then composed by an interconnection of Σ_L and Σ_C .

4.1 Brayton and Moser's Equations

In the early sixties Brayton and Moser [1] have shown that the dynamic behavior of a topologically complete¹ circuit (without external sources) is governed by the following differential equations:

$$-L(i_L) \frac{di_L}{dt} = \nabla_{i_L} \tilde{P}(i_L, v_C), \quad C(v_C) \frac{dv_C}{dt} = \nabla_{v_C} \tilde{P}(i_L, v_C), \quad (11)$$

where $L(i_L) = \nabla_{i_L} \hat{\varphi}_L(i_L) \in \mathbb{R}^{n_L \times n_L}$ is the inductance matrix, $C(v_C) = \nabla_{v_C} \hat{q}_C(v_C) \in \mathbb{R}^{n_C \times n_C}$ is the capacitance matrix, $\tilde{P} : \mathbb{R}^{n_L + n_C} \rightarrow \mathbb{R}$ is called the mixed-potential and is given by

$$\tilde{P}(i_L, v_C) = i_L^\top \Gamma v_C + F(i_L) - G(v_C), \quad (12)$$

where $\Gamma \in \mathbb{R}^{n_L \times n_C}$ is a (full rank) matrix that captures the interconnection structure between the inductors and capacitors.

¹A circuit is called 'topologically complete' if it can be described by an independent set of inductor currents and capacitor voltages such that Kirchhoff's laws are satisfied. For a detailed treatment on topological completeness, the reader is referred to [7].

If we add external sources², (11) can be written as

$$Q(x)\dot{x} = \nabla_x \tilde{P}(x) - Bv_S \quad (13)$$

where $x = \text{col}(i_L, v_C)$, $Q(x) = \text{diag}(-L(i_L), C(v_C))$ and $B = \text{col}(B_S, 0)$ with $B_S \in \mathbb{R}^{n_L \times n_S}$.

Remark 4 Notice that mixed-potential function contains both the content and co-content which are, due to the topological completeness assumption, described in terms of the inductor currents and capacitor voltages, respectively. In other words, for topologically complete circuits there exist a matrix $\Gamma_L \in \mathbb{R}^{n_{RL} \times n_L}$ such that for the resistors contained in Σ_L , $i_{R_L} = \Gamma_L i_L$, while for the resistors contained in Σ_C we have that $v_{R_C} = \Gamma_C v_C$, with $\Gamma_C \in \mathbb{R}^{n_{RC} \times n_C}$.

4.2 Generation of New Storage Function Candidates

Let us next see how the Brayton-Moser equations (13) can be used to generate storage functions for RLC circuits. From (13) we have that (compare with (2))

$$\frac{d\tilde{P}}{dt}(x) = \dot{x}^\top Q(x)\dot{x} + \dot{x}^\top Bv_S. \quad (14)$$

That is, $\frac{d\tilde{P}}{dt}(x)$ consists of the sum of a quadratic term plus the inner product of the source port variables in the desired form $\dot{x}^\top Bv_S = v_S^\top \frac{dis}{dt}$ (compare with the left-hand side of (7) of Proposition 2). Unfortunately, even under the reasonable assumption that the inductor and capacitor have convex energy functions, the presence of the negative sign in the first main diagonal block of $Q(x)$ makes the quadratic form sign-indefinite, and not negative (semi-)definite as desired. Hence, we cannot establish a power-balance inequality from (14). Moreover, to obtain the passivity property an additional difficulty stems from the fact that $\tilde{P}(x)$ is also not sign-definite.

To overcome these difficulties we borrow inspiration from [1] and look for other suitable pairs, say $Q_A(x)$ and $\tilde{P}_A(x)$, which we call *admissible*, that preserve the form of (13). More precisely, we want to find matrix functions $Q_A(x) \in \mathbb{R}^{n \times n}$, with $n = n_L + n_C$, verifying

$$Q_A^\top(x) + Q_A(x) \leq 0, \quad (15)$$

and scalar functions $\tilde{P}_A : \mathbb{R}^n \rightarrow \mathbb{R}$ (if possible, positive semi-definite), such that

$$Q_A(x)\dot{x} = \nabla_x \tilde{P}_A(x) - Bv_S. \quad (16)$$

If (15) and (16) hold, it is clear that $\frac{d\tilde{P}_A}{dt}(x) \leq v_S^\top \frac{dis}{dt}$, from which we obtain a power-balance equation with the desired port variables. Furthermore, if $\tilde{P}_A(x)$ is positive semi-definite we are able to establish the required passivity property.

In the proposition below we will provide a complete characterization of the admissible pairs $Q_A(x)$ and $\tilde{P}_A(x)$. For that, we find it convenient to use the general form (11), i.e., $Q(x)\dot{x} = \nabla_x P(x)$, where for the case considered here $P(x) = \tilde{P}(x) - x^\top Bv_S$.

Proposition 3 For any $\lambda \in \mathbb{R}$ and any constant symmetric matrix $M \in \mathbb{R}^{n \times n}$

$$Q_A(x) = \lambda Q(x) + \nabla_x^2 P(x) M Q(x) \quad (17)$$

$$P_A(x) = \lambda P(x) + \frac{1}{2} \nabla_x^\top P(x) M \nabla_x P(x). \quad (18)$$

²Restricting, for simplicity, to circuits having only voltage sources in series with the inductors.

Proof: A detailed proof of (17) and (18) can be found in [1], page 19. ■

An important observation regarding Proposition 3 is that, for suitable choices of λ and M , we can now try to generate a matrix $Q_A(x)$ with the required negativity property, i.e., $Q_A^\top(x) + Q_A(x) \leq 0$.

Remark 5 Some simple calculations show that a change of coordinate $z = \Phi : \mathbb{R}^n \rightarrow \mathbb{R}^n$ on the dynamical system (11) acts as a similarity transformation on Q . Therefore, this kind of transformation is of no use for our purposes where we want to change the sign of Q to render the quadratic form sign-definite.

4.3 Power-Balance Inequality and the New Passivity Property

Before we present our main result we first remark that in order to preserve the port variables $(v_S, \frac{di_S}{dt})$, we must ensure that the transformed dynamics (16) can be expressed in the form (13), which is equivalent to requiring that $P(x) = \tilde{P}(x) - x^\top B v_S$. This naturally restricts the freedom in the choices for λ and M in Proposition 3.

Theorem 1 Consider a (possibly nonlinear) RLC circuit satisfying (13). Assume:

- A.1 The inductors and capacitors are passive and have strictly convex energy functions.
- A.2 The voltage-controlled resistors R_C in Σ_C are passive, linear and time-invariant. Also, $\det(R_C) \neq 0$, and thus $G(v_C) = \frac{1}{2} v_C^\top R_C^{-1} v_C \geq 0$ for all v_C .
- A.3 Uniformly in i_L, v_C we have $\|C^{\frac{1}{2}}(v_C) R_C \Gamma^\top L^{-\frac{1}{2}}(i_L)\| < 1$, where $\|\cdot\|$ denotes the spectral norm of a matrix.

Under these conditions, we have the following power-balance inequality

$$\int_0^t v_S^\top(t') \frac{di_S}{dt'}(t') dt' \geq \tilde{P}_A[i_L(t), v_C(t)] - \tilde{P}_A[i_L(0), v_C(0)], \quad (19)$$

where the transformed mixed-potential function is defined as

$$\begin{aligned} \tilde{P}_A(i_L, v_C) = & F(i_L) + \frac{1}{2} i_L^\top \Gamma R_C \Gamma^\top i_L \\ & + \frac{1}{2} (\Gamma^\top i_L - R_C^{-1} v_C)^\top R_C (\Gamma^\top i_L - R_C^{-1} v_C). \end{aligned}$$

If, furthermore

- A.4 The current-controlled resistors are passive, i.e., $F(i_L) \geq 0$.

Then, the circuit defines a passive system with port variables $(v_S, \frac{di_S}{dt})$ and storage function the transformed mixed-potential $\tilde{P}_A(i_L, v_C)$.

Proof: The proof consists in first defining the parameters λ and M of Proposition 3 so that, under the conditions A.1–A.4 of the theorem, the resulting Q_A satisfies (15) and \tilde{P}_A is a positive semi-definite function.

First, notice that under assumption A.2 the co-content is linear and quadratic. To ensure that $\tilde{P}(x)$ is linear in v_S , as is required to preserve the desired port variables, we may select $\lambda = 1$ and $M = \text{diag}(0, 2R_C)$. Now, using (17) we obtain after some straight forward calculations

$$Q_A(i_L, v_C) = \begin{bmatrix} -L(i_L) & 2R_C \Gamma C(v_C) \\ 0 & -C(v_C) \end{bmatrix}.$$

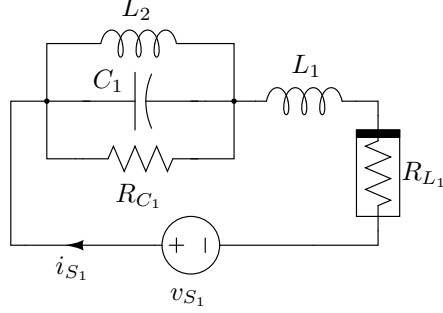

Figure 1: Simple RLC circuit with nonlinear current-controlled resistor.

Assumption A.1 ensures that $L(i_L)$ and $C(v_C)$ are positive definite. Hence, a Schur complement analysis proves that, under Assumption A.3, (19) holds. This proves the power-balance inequality. Passivity follows from the fact that, under Assumption A.2 and A.4, the mixed-potential function $\tilde{P}_A(i_L, v_C)$ is positive semi-definite for all i_L and v_C . This completes the proof. \blacksquare

Remark 6 Assumption A.3 is satisfied if the voltage-controlled resistances $R_{C_k} \in R_C$ are ‘small’. Recalling that these resistors are contained in Σ_C , this means that the coupling between Σ_L and Σ_C , that is, the coupling between the inductors and capacitors, is weak.

Remark 7 We have considered here only voltage sources, some preliminary calculations suggest that current sources can be treated analogously using an alternative definition of the mixed potential. Furthermore, it is interesting to underscore that from (14) we can obtain, as a particular case with $\tilde{P}(i_L) = F(i_L)$, the new passivity property for RL circuits of Proposition 2, namely

$$\frac{dF}{dt}(i_L) = v_S^\top \frac{di_S}{dt} - v_L^\top \nabla_{\varphi_L}^2 E_L(\varphi_L) v_L.$$

However, the corresponding property for RC circuits,

$$\frac{dG}{dt}(v_C) = i_S^\top \frac{dv_S}{dt} - i_C^\top \nabla_{q_C}^2 E_C(q_C) i_C$$

does not follow directly from (14), as it requires the utilization of (3) instead of (2), as done above.

5. Example

Consider the RLC circuit depicted in Figure 1. For simplicity assume that all the circuit elements are linear and time-invariant, except for the resistor R_{L_1} . The voltage–current relation of R_{L_1} is described by $v_{R_{L_1}} = f_{R_{L_1}}(i_{L_1})$. The interconnection matrix Γ , the content $F(i_{L_1})$ and the co-content $G(v_{C_1})$ are readily found to be $\Gamma = [1, -1]^\top$, $F(i_{L_1}) = \int_0^{i_{L_1}} f_{R_{L_1}}(i'_{L_1}) di'_{L_1}$ and $G(v_{C_1}) = \frac{1}{2R_{C_1}} v_{C_1}^2$, respectively, and thus, the mixed-potential for the circuit is

$$\tilde{P}(i_{L_1}, i_{L_2}, v_{C_1}) = \int_0^{i_{L_1}} f_{R_{L_1}}(i'_{L_1}) di'_{L_1} - \frac{1}{2R_{C_1}} v_{C_1}^2 + i_{L_1} v_{C_1} - i_{L_2} v_{C_1}.$$

Hence, the differential equations describing the dynamics of the circuit are given by

$$\begin{aligned} -L_1 \frac{di_{L_1}}{dt} &= f_{R_{L_1}}(i_{L_1}) - v_{S_1} + v_{C_1} \\ -L_2 \frac{di_{L_2}}{dt} &= -v_{C_1} \\ C_1 \frac{dv_{C_1}}{dt} &= i_{L_1} - \frac{v_{C_1}}{R_{C_1}} - i_{L_2}. \end{aligned}$$

The new passivity property is obtained by selecting $\lambda = 1$ and $M = \text{diag}(0, 0, 2R_{C_1})$, yielding that $Q_A^\top + Q_A \leq 0$ if and only if

$$R_{C_1} < \sqrt{\frac{L_1 L_2}{C_1(L_1 + L_2)}}. \quad (20)$$

Under the condition that $F(i_{L_1}) \geq 0$ and $R_{C_1} > 0$, positivity of \tilde{P}_A is easily checked by calculating (18), i.e.,

$$\tilde{P}_A(i_{L_1}, i_{L_2}, v_{C_1}) = \int_0^{i_{L_1}} f_{R_{L_1}}(i'_{L_1}) di'_{L_1} + \frac{R_{C_1}}{2}(i_{L_1}^2 + i_{L_2}^2) + \frac{R_{C_1}}{2} \left(i_{L_1} - i_{L_2} - \frac{v_{C_1}}{R_{C_1}} \right)^2.$$

In conclusion, if (20) is satisfied, then the circuit of Figure 1 defines a passive system with port variables $(v_{S_1}, \frac{di_{L_1}}{dt})$ and storage function $\tilde{P}_A(i_{L_1}, i_{L_2}, v_{C_1}) \geq 0$.

6. Concluding Remarks

Our main motivation in this paper was to establish a new passivity property for RL, RC and a class of RLC circuits. We have proven that for this class of circuits it is possible to ‘add a differentiation’ to the port variables preserving passivity with respect to a storage function which is directly related to the circuit’s power. The new supply rate naturally coincides with the definition of reactive power.

Instrumental for our developments was the exploitation of Tellegen’s theorem. Dirac structures, as proposed in [6], provide a natural generalization to this theorem, characterizing in an elegant geometrical language the key notion of power preserving interconnections. It seems that this is the right notion to try to extend our results beyond the realm of RLC circuits, e.g., to mechanical or electromechanical systems. A related question is whether we can find Brayton–Moser like models for this class of systems.

There are close connections of our result and the Shrinking Dissipation Theorem of [8], which is extensively used in analog VLSI circuit design. Exploring the ramifications of our research in that direction is a question of significant practical interest.

Acknowledgments

The authors would like to thank R. Griño for his useful remarks regarding the interpretation of the new storage function as a reactive power. The second author would like to express his gratitude to B.E. Shi with whom this research started.

References

- [1] R.K. Brayton and J.K. Moser, A theory of nonlinear networks - I, *Quart. of App. Math.*, vol. 22, pp 1–33, April, 1964.
- [2] C. A. Desoer and E. S. Kuh, *Basic Circuit Theory*, McGraw–Hill, NY, 1969.
- [3] W. Millar, Some general theorems for nonlinear systems possessing resistor, *Phil. Mag.*, vol. 42, 1951, pp. 1150–1160.

- [4] R. Ortega, D. Jeltsema and J.M.A. Scherpen, ‘Stabilization of nonlinear RLC circuits via power-shaping’, in Proc. Latin American Conf. on Aut. Contr., Guadalajara, México, December 2002.
- [5] P. Penfield, R. Spence and S. Duinker, *Tellegen’s Theorem and Electrical Networks*, MIT Press, 1970.
- [6] A.J. van der Schaft, *\mathcal{L}_2 -Gain and Passivity Techniques in Nonlinear Control*, Springer-Verlag, London, 2000.
- [7] L. Weiss, W. Mathis and L. Trajkovic, A generalization of Brayton–Moser’s mixed potential function, *IEEE Trans. Circuits and Systems - I*, April 1998.
- [8] J. L. Wyatt, Little-known properties of resistive grids that are useful in analog vision chip designs, in *Vision Chips: Implementing Vision Algorithms with Analog VLSI Circuits*, eds. C. Koch and H. Li, IEEE Computer Science Press, NJ, 1995.