

University of Groningen

Gradient System Modelling of Matrix Converters with Input and Output Filters

Jeltsema, Dimitri; Scherpen, Jacquélien M.A.; Klaassens, J. Ben

Published in:

Proceedings of the 10th European Conference on Power Electronics and Applications, EPE 2003

IMPORTANT NOTE: You are advised to consult the publisher's version (publisher's PDF) if you wish to cite from it. Please check the document version below.

Document Version

Publisher's PDF, also known as Version of record

Publication date:

2003

[Link to publication in University of Groningen/UMCG research database](#)

Citation for published version (APA):

Jeltsema, D., Scherpen, J. M. A., & Klaassens, J. B. (2003). Gradient System Modelling of Matrix Converters with Input and Output Filters. In *Proceedings of the 10th European Conference on Power Electronics and Applications, EPE 2003* (pp. 1-10). University of Groningen, Research Institute of Technology and Management.

Copyright

Other than for strictly personal use, it is not permitted to download or to forward/distribute the text or part of it without the consent of the author(s) and/or copyright holder(s), unless the work is under an open content license (like Creative Commons).

The publication may also be distributed here under the terms of Article 25fa of the Dutch Copyright Act, indicated by the "Taverne" license. More information can be found on the University of Groningen website: <https://www.rug.nl/library/open-access/self-archiving-pure/taverne-amendment>.

Take-down policy

If you believe that this document breaches copyright please contact us providing details, and we will remove access to the work immediately and investigate your claim.

Downloaded from the University of Groningen/UMCG research database (Pure): <http://www.rug.nl/research/portal>. For technical reasons the number of authors shown on this cover page is limited to 10 maximum.

Gradient System Modelling of Matrix Converters with Input and Output Filters

Dimitri Jeltsema, Jacquélien M.A. Scherpen and J. Ben Klaassens

Delft Center of Systems and Control
Delft University of Technology
P.O. Box 5031, 2600 GA Delft, The Netherlands
Fax: +31-(0)-15-2786679

Email: d.jeltsema/j.b.klaassens/j.m.a.scherpen@dcsc.tudelft.nl

Keywords: Matrix Converters, Modelling, Converter Circuits, Control.

Abstract: Due to its complexity, the dynamics of matrix converters are usually neglected in controller design. However, increasing demands on reduced harmonic generation and higher bandwidths makes it necessary to study large-signal dynamics. A unified methodology that considers matrix converters, including input and output filters, as gradient systems is presented.

1 Motivation

Matrix converters are complex hybrid devices, which are becoming ubiquitous in many large scale industrial energy conversion applications. In the last decade, considerable research effort has been devoted to the modelling, analysis and control of matrix converters, see for instance [1, 3, 4, 8, 11, 12, 14] or [13] for some recent results. Due to their high complexity, the dynamic behavior is typically neglected at the controller design stage and usually only the (quasi-)static behavior is concerned. However, since the increasing demands on harmonic generation and EMI (ElectroMagnetic Interference) requirements, a matrix converter is usually preceded by an input filter and connected to the load via an output filter.

From practical applications it is well-known that the inclusion of filters can cause undesirable phenomena, like oscillations and power reflections during start-up and transient conditions. These filters also seriously restrict the achievable bandwidth of the overall system. Another problem is the phase shift, caused by the input filter, between the input currents and voltages, which varies with the load and with the magnitude of the input voltages. To overcome the aforementioned stability problems and to achieve unity power factor operation, it is necessary to incorporate the dynamics of the filters in the control schemes. Therefore a thorough understanding of the available matrix converter topologies as a system is required and one must be able to analyze behavior like stability and transient response.

The objective of this paper is to present a unified method to model the dynamics of a large family of matrix converters including passive filter elements, like capacitors, inductors and (non-ideal) transformers. This model can then be used to analyze the dynamical behavior and to design feedback controllers. The key observation here is that the semiconductor power switching devices (SPSD's) of the matrix converter circuit can be thought of as a conductive circuit with $\alpha + \beta$ external ports, where α represents the number of input terminals and β the number of output terminals, to which an arbitrary number of (multi-port) inductors and/or capacitors is attached, see Figure 1.

In this paper we will show that the circuit of Figure 1 establishes a *gradient* system, or more specifically, a *Brayton-Moser* circuit [2, 10], and, if it is well-controlled, forms a prototype of a high-efficient non-oscillatory circuit with a dissipative characteristic. This is naturally formalized by requiring the existence of a potential function that is decreasing along the trajectories of the currents and voltages in the circuit if no external energy is supplied. Consequently, the form of the equations describing the circuit is basically as follows [2]:

$$\dot{z} = Q^{-1}(z) \frac{\partial P}{\partial z}(z, \Phi), \quad (1)$$

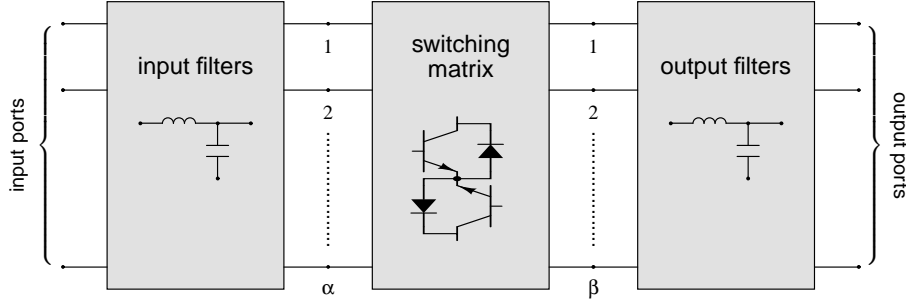

Figure 1: General structure of a $\alpha \times \beta$ matrix converter with passive filter elements

where z represents the capacitor voltages and inductor currents, respectively, Φ represents the input and output phase (port) currents and voltages while $Q(z)$ contains the values of the (possibly nonlinear) filter inductors and capacitors. The scalar function $P(z, \Phi)$ is called the *mixed-potential* function of the circuit and consist of the power related to the characteristics of the conductances (SPSD's) and the power flows at input and output terminals. One of the main advantages is that in this way we have a compact representation of the circuit dynamics, while complicated functional relations of the SPSPD's can be easily included in the definition of the conductances.

Due to the switching characteristics, the dynamics of a matrix converter are highly nonlinear. In general, the question of the stability of an equilibrium solution can be studied by two methods. One is the standard method of investigating the structure of the variational equations by linearizing the dynamics of equation (1). In this paper we present nonlinear Lyapunov-like stability criteria to ensure stability of the converter in the presence of input and output filters using the functions $Q(z)$ and $P(z, \Phi)$. A major advantage of the proposed method is that the dynamics do not have to be linearized to investigate stability. Besides the fact that the proposed method yields *large-signal* results, cumbersome calculations to obtain the linearized models are avoided.

2 Modelling Procedure

Consider the general basic topology of the matrix converter circuit depicted in Figure 2. The SPSPD's in the circuit are represented by (possibly nonlinear) two-state controllable conductances $G_{j,k} = G_{j,k}(\cdot)$.¹ We assume that the power flow can be conducted in both directions and that the state transition can, though smoothly, take place in an arbitrary time instant, i.e., the SPSPD's can be smoothly switched ON and OFF arbitrarily fast. The state-transition of the SPSPD's can be described as follows:

$$G_{j,k} = \begin{cases} G_{j,k}^1 \text{ (high), i.e., switch is ON} \\ G_{j,k}^0 \text{ (low), i.e., switch is OFF.} \end{cases} \quad (2)$$

2.1 Switching Surface

From a circuit theoretic point of view, the matrix matrix converter may be considered as an $(\alpha + \beta)$ -port G -circuit². In general, there exist $\alpha + \beta$ relations between the $2(\alpha + \beta)$ port variables, $i_\gamma = \text{col}(i_{\gamma_1}, \dots, i_{\gamma_\gamma}) \in \mathbb{J}^\gamma$ and $v_\gamma = \text{col}(v_{\gamma_1}, \dots, v_{\gamma_\gamma}) \in \mathbb{V}^\gamma$ with $\gamma \in \{\alpha, \beta\}$, such that $\alpha + \beta$ of them can be considered independent. Geometrically speaking, this means that that in the $2(\alpha + \beta)$ -dimensional space $\mathbb{S} = \mathbb{J}^\alpha \times \mathbb{J}^\beta \times \mathbb{V}^\alpha \times \mathbb{V}^\beta$ we have an $(\alpha + \beta)$ -dimensional subspace $\mathbb{S}' \subset \mathbb{S}$, referred to as the *switching surface*, which is characteristic for the external behavior at the ports. If the voltages are prescribed (e.g. the ports are terminated by voltage sources), the relations between i_γ and v_γ are determined by [2]

$$i_\gamma = \frac{\partial F^*}{\partial v_\gamma}(v_\alpha, v_\beta), \quad (3)$$

¹By $G_{j,k}(\cdot)$ we denote that $G_{j,k}$ depends on yet to be defined variables ' \cdot ' (via control). For example: $G_{j,k} = G_{j,k}(t)$.

²The magnitude of the $\alpha + \beta$ voltages are defined with respect the an arbitrary reference voltage and form $(\alpha + \beta)$ ports relative to this reference.

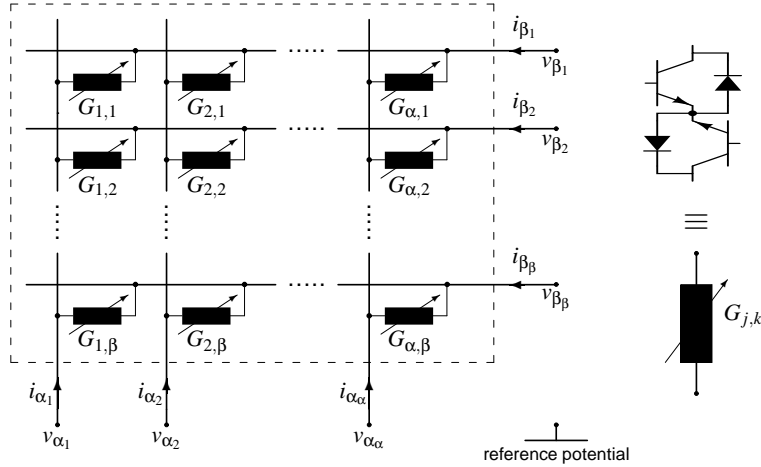

Figure 2: Basic topology of an $\alpha \times \beta$ matrix converter. The SPST's are modelled as two-state controllable conductances $G_{j,k}$.

where the *voltage potential* $F^*(v_\alpha, v_\beta) : \mathbb{V}^\alpha \times \mathbb{V}^\beta \rightarrow \mathbb{R}$ is a scalar function, describing the switching surface \mathbb{S}' . In case the conductances do not depend on v_α and/or v_β , this function is a quadratic form given by $F^*(v_\alpha, v_\beta) = \frac{1}{2}v_\alpha^\top G_{\alpha\alpha}v_\alpha + \frac{1}{2}v_\beta^\top G_{\beta\beta}v_\beta + v_\alpha^\top G_{\alpha\beta}v_\beta$, in which $G_{\alpha\alpha}$ and $G_{\beta\beta}$ are diagonal matrices of the form

$$G_{\alpha\alpha} = \sum_{j=1}^{\beta} \begin{bmatrix} G_{1,j} & 0 & \cdots & 0 \\ 0 & G_{2,j} & \cdots & 0 \\ \vdots & \vdots & \ddots & \vdots \\ 0 & 0 & \cdots & G_{\alpha,j} \end{bmatrix} \text{ and } G_{\beta\beta} = \sum_{k=1}^{\alpha} \begin{bmatrix} G_{k,1} & 0 & \cdots & 0 \\ 0 & G_{k,2} & \cdots & 0 \\ \vdots & \vdots & \ddots & \vdots \\ 0 & 0 & \cdots & G_{k,\beta} \end{bmatrix},$$

respectively, while $G_{\alpha\beta} = G_{\beta\alpha}^\top$ is a matrix of the form

$$G_{\alpha\beta} = \begin{bmatrix} G_{1,1} & G_{1,2} & \cdots & G_{1,\beta} \\ G_{2,1} & G_{2,2} & \cdots & G_{2,\beta} \\ \vdots & \vdots & \ddots & \vdots \\ G_{\alpha,1} & G_{\alpha,2} & \cdots & G_{\alpha,\beta} \end{bmatrix}.$$

Similarly, if the current are prescribed (e.g. the ports are terminated by current sources), we have that

$$v_\gamma = \frac{\partial F}{\partial i_\gamma}(i_\alpha, i_\beta), \quad (4)$$

where the *current potential* $F(i_\alpha, i_\beta)$ is again a scalar function, defined by $F + F^* = i_\alpha^\top v_\alpha + i_\beta^\top v_\beta$. The latter equality represents nothing else than a generalized Δ -Y (or Legendre) transformation. Hence, (3) and (4) describe the same surface \mathbb{S}' and they can be considered as transformations which are inverse to each other. Indeed, in case the switching surface is described using the current potential, it is easily checked that the conductances in Figure 2 act as resistances $R_{j,k} = G_{j,k}^{-1}$. Notice that $F + F^*$ is precisely the total power dissipated in the SPST's, while in the linear case $F^* = F$ equals half the dissipated power, see also Figure 3. According to the definitions introduced in [10], we may regard the matrix converter behavior described by (3) or (4) as a memoryless (static) *gradient* system.

2.2 Inclusion of Passive Filter Elements

In the previous subsection we have shown that the behavior of an $\alpha \times \beta$ matrix converter topology can be considered as a static gradient system exposing $\alpha + \beta$ free ports. In a practical situation the matrix converter is usually preceded by passive filter elements, like inductors, capacitors and resistors, to meet the demands on harmonic generation and EMI (ElectroMagnetic Interference) requirements. As already argued in Section 1, under certain conditions on the (filter) element values, a gradient system forms a

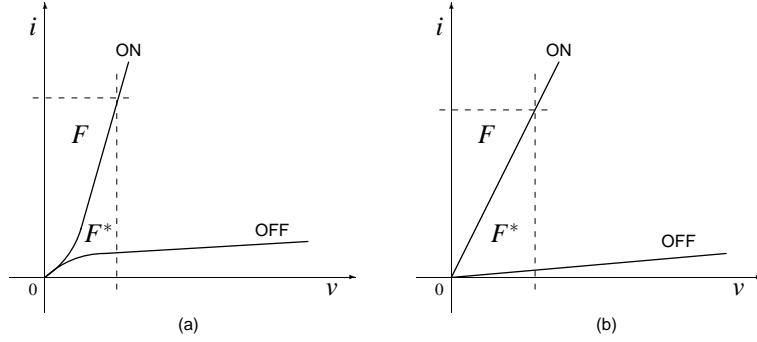

Figure 3: Examples of conductance curves of the SPSS's: (a) smooth nonlinear characteristic, (b) linear characteristic. The total dissipated power in both cases is equal to $F + F^* (= vi)$, while in the linear case, $F = F^* (= \frac{1}{2} vi)$.

prototype of a non-oscillatory dissipative system and its structure can be advantageously used to investigate qualitative properties, like stability and transient behavior. For that reason we are interested to extend the ideas outlined in the previous subsection to arrive at a gradient system description of a matrix converter including arbitrary filter structures.

A very nice example of a particular class of (dynamical) gradient systems are electrical circuits that can be described by the Brayton-Moser equations [2]. The basic idea is to consider a R(G)LC circuit as a resistive (resp. conductive) circuit with an arbitrary number of free ports to which either a capacitor or an inductor is attached. In the following subsection it is our interest to translate this idea to the matrix converter described by either (3) or (4). The inclusion of filter elements then simply follow by terminating the free ports by either capacitors or inductors. The same holds for the inclusion of voltage (resp. current) sources.

First, we will consider a matrix converter having its ports terminated by capacitors and current sources only. Secondly, its dual is presented (i.e., the matrix converter including inductors and voltage sources only). Finally, the two separate models are combined to obtain a description of a matrix converter with general input and output filters.

2.2.1 Current-Mode Operation

Suppose that the ' α -side' of the matrix converter is terminated by α (possibly nonlinear) capacitors, captured by the $\alpha \times \alpha$ matrix C_α , and that the ' β -side' is terminated by independent current sources I_β . The resulting circuit topology is depicted in left-hand scheme of Figure 4. Consequently, the corresponding voltages associated with the capacitors are then given by v_α . The resulting converter can then be considered as a multi-phase *current source inverter* [3]. Furthermore, the equation describing the dynamical behavior of the converter using the voltage potential function F^* are determined by

$$C_\alpha(v_\alpha) \frac{dv_\alpha}{dt} = -\frac{\partial F^*}{\partial v_\alpha}(v_\alpha, v_\beta) + I_\alpha, \quad (5)$$

where I_α represents the auxiliary currents, which we will use later on to interconnect the circuit with passive elements and sources. Notice that the ' β -side' port voltages v_β can be written in terms of the current sources $i_\beta = I_\beta$ and v_α as $v_\beta = \hat{v}_\beta(v_\alpha, I_\beta) = G_{\beta\beta}^{-1} I_\beta - G_{\beta\beta}^{-1} G_{\beta\alpha} v_\alpha$, which yields after some simple calculations that $F^*(v_\alpha, v_\beta)|_{v_\beta = \hat{v}_\beta(v_\alpha, I_\beta)} = F^*(v_\alpha, I_\beta)$, with

$$F^*(v_\alpha, I_\beta) = \underbrace{\frac{1}{2} v_\alpha^\top [G_{\alpha\alpha} - G_{\beta\alpha}^\top G_{\beta\beta}^{-1} G_{\beta\alpha}] v_\alpha}_{F_d^*(v_\alpha)} + \underbrace{v_\alpha^\top G_{\alpha\beta} G_{\beta\beta}^{-1} I_\beta}_{F_e^*(v_\alpha, I_\beta)}.$$

The latter function constitutes the characteristic of the circuit defined on the switching surface \mathbb{S}' . Furthermore, if we split the voltage potential in two parts, a dissipative part $F_d^*(v_\alpha)$ and an externally supplied

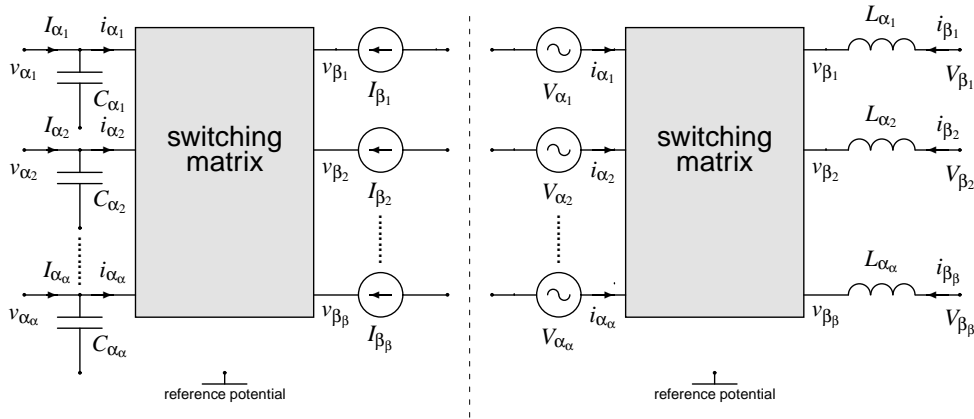

Figure 4: Matrix converter with passive filter elements: (left) current-mode topology; (right) voltage-mode topology.

part $F_e^*(v_\alpha, I_\beta)$, we may rewrite (5) as

$$\begin{aligned} C_\alpha(v_\alpha) \frac{dv_\alpha}{dt} &= -\frac{\partial}{\partial v_\alpha} [F_d^*(v_\alpha) + F_e^*(v_\alpha, I_\beta)] + I_\alpha \\ &= -\frac{\partial F_d^*}{\partial v_\alpha}(v_\alpha) - G_{\alpha\beta} G_{\beta\beta}^{-1} I_\beta + I_\alpha. \end{aligned} \quad (6)$$

The key motivation of equating the converter's dynamic behavior in the form (6) is that, after pre-multiplication with \dot{v}_α^\top , we can advantageously use the fact that the resulting equation yields $\dot{F}_d^*(v_\alpha) = \dot{v}_\alpha^\top [I_\alpha - G_{\alpha\beta} G_{\beta\beta}^{-1} I_\beta] - \dot{v}_\alpha^\top C_\alpha(v_\alpha) \dot{v}_\alpha$, which constitutes the (reactive) power-balance of the circuit. Hence, if $C_\alpha(v_\alpha) \geq 0$ then (6) obviously satisfies the inequality

$$\dot{F}_d^*(v_\alpha) \leq \left(\frac{dv_\alpha}{dt} \right)^\top [I_\alpha - G_{\alpha\beta} G_{\beta\beta}^{-1} I_\beta]. \quad (7)$$

Following some recent ideas [2] and [6], we may conclude that if also $F_d^*(v_\alpha) \geq 0$, the converter defines a passive system with supply rate $\dot{v}_\alpha^\top [I_\alpha - G_{\alpha\beta} G_{\beta\beta}^{-1} I_\beta]$ and storage (Lyapunov) function $F_d^*(v_\alpha)$. The latter case suggests that every trajectory of (6) tends to (one of) the periodical equilibrium orbits $v_\alpha = v_\alpha^*$ as $t \rightarrow \infty$.

2.2.2 Voltage-Mode Operation

Along the same lines as Subsection 2.2.1, we will consider the case that the ' β -side' of the matrix converter is terminated by β (possibly nonlinear) inductors, captured by the $\beta \times \beta$ matrix L_β , and that the ' α -side' is terminated by independent voltage sources V_α . The resulting converter, depicted in the right-hand scheme of Figure 4, can now be considered as a multi-phase *voltage source inverter* [3] and its dynamic behavior is described by the equation

$$-L_\beta(i_\beta) \frac{di_\beta}{dt} = \frac{\partial F_d}{\partial i_\beta}(i_\beta) + G_{\beta\beta}^{-1} G_{\beta\alpha} V_\alpha - V_\beta, \quad (8)$$

where V_β represents the auxiliary voltages, while the dissipative part of the current potential is given by $F_d(i_\beta) = \frac{1}{2} i_\beta^\top G_{\beta\beta}^{-1} i_\beta$. Notice that (8) precisely presents the dual of (6). Hence, in a similar fashion as in Subsection 2.2.1, if $L_\beta(i_\beta) \geq 0$ then (8) satisfies (compare with (7))

$$\dot{F}_d(i_\beta) \leq \left(\frac{di_\beta}{dt} \right)^\top [V_\beta - G_{\beta\beta}^{-1} G_{\beta\alpha} V_\alpha] \quad (9)$$

which, under the condition that $F_d(i_\beta) \geq 0$, suggests that every trajectory of (8) tends to (one of) the periodical equilibrium orbits $i_\beta = i_\beta^*$ as $t \rightarrow \infty$. We are now ready to present the complete Brayton-Moser model of the matrix converter with arbitrary input and output filter circuits.

2.3 The Complete Model

Consider again that the ‘ α -side’ of the matrix converter is terminated by α capacitors, captured by the $\alpha \times \alpha$ matrix C_α , and that the ‘ β -side’ is terminated by β inductors, captured by the $\beta \times \beta$ matrix L_β . The corresponding voltages associated with the capacitors are given by v_α , while the corresponding current associated with the inductors are i_β . Hence, if we take v_α and i_β as the independent variables, then, by using the relations (6) and (8), the equations describing the dynamical behavior of the converter should read as

$$C_\alpha(v_\alpha) \frac{dv_\alpha}{dt} = -\frac{\partial F_d^*}{\partial v_\alpha}(v_\alpha) + G_{\alpha\beta} G_{\beta\beta}^{-1} i_\beta + I_\alpha \quad (10)$$

$$-L_\beta(i_\beta) \frac{di_\beta}{dt} = \frac{\partial F_d}{\partial i_\beta}(i_\beta) + G_{\beta\beta}^{-1} G_{\beta\alpha} v_\alpha - V_\beta, \quad (11)$$

where again I_α and V_β represent the auxiliary currents and voltages, respectively. Notice that the interconnection of the two basic topologies (6) and (8) is realized by the terms $G_{\alpha\beta} G_{\beta\beta}^{-1} i_\beta$ and $G_{\beta\beta}^{-1} G_{\beta\alpha} v_\alpha$, respectively. Next, we are interested in writing the latter equations in a similar form as (1), using a single potential function. To do this, we proceed as follows. First, recall that both $F_d^*(v_\alpha)$ and $F_d(i_\beta)$ represent a measure for the power dissipated in the SPSD’s, which in case of linear SPSD’s both represent half the dissipated power. Secondly, it is recognized that the (workless) power due to the interconnection of (6) and (8) is given by $v_\alpha^\top G_{\alpha\beta} G_{\beta\beta}^{-1} i_\beta$. This immediately suggests that if we combine the latter properties and define a function $P : \mathbb{S}' \rightarrow \mathbb{R}$ of the form

$$P(v_\alpha, i_\beta) = F_d(i_\beta) - F_d^*(v_\alpha) + i_\beta^\top G_{\beta\beta}^{-1} G_{\beta\alpha} v_\alpha, \quad (12)$$

equations (10) and (11) can be written as

$$C_\alpha(v_\alpha) \frac{dv_\alpha}{dt} = \frac{\partial P}{\partial v_\alpha}(v_\alpha, i_\beta) + I_\alpha \quad \text{and} \quad -L_\beta(i_\beta) \frac{di_\beta}{dt} = \frac{\partial P}{\partial i_\beta}(v_\alpha, i_\beta) - V_\beta. \quad (13)$$

The function $P(v_\alpha, i_\beta)$ represents the *mixed-potential* function describing the total characteristic of the circuit [2]. For ease of notation, (13) can be written in the following compact matrix form

$$\dot{z} = Q^{-1}(z) \frac{\partial P}{\partial z}(z) - Q^{-1}(z) \Phi. \quad (14)$$

Here we have defined $z = \text{col}(z^\alpha, z^\beta)$, with $z^\alpha = v_\alpha$ and $z^\beta = i_\beta$, $Q(z) = \text{diag}(C_\alpha(v_\alpha), -L_\beta(i_\beta))$, while $\Phi = \text{col}(-I_\alpha, V_\beta)$ again represent the external ports of the circuit. Equation (14) is slightly different from (1) in the sense that we excluded the external sources from the mixed-potential function. This in order to be able to draw similar conclusions based on the (reactive) power-balance as in Subsection 2.2.1 and 2.2.2. Notice that the power at the external ports equals $\Phi^\top z$ and that $P(z)$ has the units of power.

In practical applications, the input capacitors are usually preceded by additional passive filter elements, whereas the output inductors are connected to additional passive filter elements followed by the load. From a topological point of view, inclusion of additional elements can be viewed as a standard interconnection. To see this, let $u = \text{col}(u^\alpha, u^\beta)$ and $y = \text{col}(y^\alpha, y^\beta)$ represent the input and output signals of the additional input filter (connected to the ‘ α -side’ of the converter) and output filter (connected to the ‘ β -side’ of the converter) sub-circuits, respectively. Furthermore, denote the additional mixed-potential by $P_{\text{fil}}(\tilde{z})$, where $\tilde{z} = \text{col}(\tilde{z}^\alpha, \tilde{z}^\beta)$ denotes the (arbitrary number of) independent state variables of the additional filter sub-circuits, i.e., the voltages across the additional filter capacitors and the currents through the additional filter inductors. The interconnection of the matrix converter circuit described by (14) with the additional filter sub-circuits is accomplished as shown in Figure 5.

Let the dynamics of the filter sub-circuits be represented by another gradient system description given by

$$\dot{\tilde{z}} = Q_{\text{fil}}^{-1}(\tilde{z}) \frac{\partial P_{\text{fil}}}{\partial \tilde{z}}(\tilde{z}) - Q_{\text{fil}}^{-1}(\tilde{z}) u, \quad (15)$$

then the additional filter circuits are interconnected with the converter via the external ports, i.e., $\Phi = -y + \Phi_e$, with Φ_e the (optional) external signals of the converter and $y = A^\top \tilde{z}$, with A a matrix of appropriate dimensions selecting the port variables to be interconnected. Furthermore, $u = Az + \tilde{\Phi}_e$ as

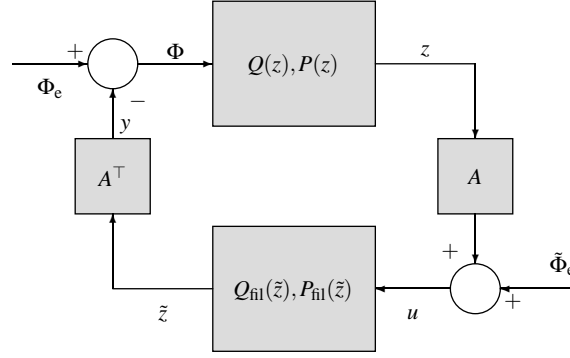

Figure 5: Interconnection of the matrix converter described by (14) with additional filter sub-circuits.

can be seen from Figure 5, with $\tilde{\Phi}_e$ representing the external signals (voltage and/or current sources) of the filters. The complete dynamics of the interconnected system take the form

$$\begin{bmatrix} \dot{z} \\ \dot{\tilde{z}} \end{bmatrix} = \underbrace{\begin{bmatrix} Q^{-1}(z) & 0 \\ 0 & Q_{\text{fil}}^{-1}(\tilde{z}) \end{bmatrix}}_{Q_{\text{tot}}^{-1}(z, \tilde{z})} \begin{bmatrix} \frac{\partial P_{\text{tot}}}{\partial z}(z, \tilde{z}) \\ \frac{\partial P_{\text{tot}}}{\partial \tilde{z}}(z, \tilde{z}) \end{bmatrix} - \begin{bmatrix} Q^{-1}(z) & 0 \\ 0 & Q_{\text{fil}}^{-1}(\tilde{z}) \end{bmatrix} \begin{bmatrix} \Phi_e \\ \tilde{\Phi}_e \end{bmatrix},$$

or in sort notation, with $\hat{z} = \text{col}(z, \tilde{z})$ and $\hat{\Phi}_e = \text{col}(\Phi_e, \tilde{\Phi}_e)$, read as

$$\dot{\hat{z}} = Q_{\text{tot}}^{-1}(\hat{z}) \frac{\partial P_{\text{tot}}}{\partial \hat{z}}(\hat{z}) - Q_{\text{tot}}^{-1}(\hat{z}) \hat{\Phi}_e, \quad (16)$$

The latter system is again a Brayton-Moser system having a characteristic $P_{\text{tot}}(\hat{z}) = P_{\text{tot}}(z, \tilde{z}) = P(z) + P_{\text{fil}}(\tilde{z}) - \tilde{z}^T A z$. Notice that if $\tilde{\Phi}_e = 0$, the power at the ports equals $-\tilde{z}^T A z = \Phi_e^T z$ which implies that the interconnection is power preserving. Let us next consider an example to demonstrate the proposed modelling procedure.

3 Example: 3×3 Matrix Converter

Consider the three-by-three phase matrix converter shown in Figure 6. The converter is driven by 3 sinusoidal voltage sources V_{e_k} , $k = 1, 2, 3$. The input filter is a simple LC filter (formed by L_{α_k} and C_{α_k}) with switchable damping resistors μR_{α_k} , where μ takes values in the discrete set $\{0, 1\}$ (switch is OFF or ON, respectively). The converter's load is formed by three RL circuits (formed by L_{β_k} and R_{β_k}). Since $\alpha = \beta = 3$, the matrices $G_{\beta\alpha}$, $G_{\beta\beta}$ and $G_{\alpha\alpha}$ are given by

$$G_{\beta\alpha} = \begin{bmatrix} G_{1,1} & G_{2,1} & G_{3,1} \\ G_{1,2} & G_{2,2} & G_{3,2} \\ G_{1,3} & G_{2,3} & G_{3,3} \end{bmatrix}, \quad G_{\beta\beta} = \begin{bmatrix} G_{1,1} + G_{2,1} + G_{3,1} & 0 & 0 \\ 0 & G_{1,2} + G_{2,2} + G_{3,2} & 0 \\ 0 & 0 & G_{1,3} + G_{2,3} + G_{3,3} \end{bmatrix},$$

and

$$G_{\alpha\alpha} = \begin{bmatrix} G_{1,1} + G_{1,2} + G_{1,3} & 0 & 0 \\ 0 & G_{2,1} + G_{2,2} + G_{2,3} & 0 \\ 0 & 0 & G_{3,1} + G_{3,2} + G_{3,3} \end{bmatrix},$$

respectively. Furthermore, the voltage and current vectors are defined by $z^\alpha = \text{col}(v_{\alpha_1}, v_{\alpha_2}, v_{\alpha_3})$, $z^\beta = \text{col}(i_{\beta_1}, i_{\beta_2}, i_{\beta_3})$, $\tilde{z}^\alpha = \text{col}(\tilde{i}_{\alpha_1}, \tilde{i}_{\alpha_2}, \tilde{i}_{\alpha_3})$ and $\tilde{\Phi}_e^\alpha = \text{col}(V_{e_1}, V_{e_2}, V_{e_3})$, while $\tilde{z}^\beta = 0$, $\tilde{\Phi}_e^\beta = 0$ and $\Phi_e = 0$.

Since, the additional (filter) elements are given by μR_{α_k} , L_{α_k} and R_{β_k} , the additional mixed potential function should read $P_{\text{fil}}(\tilde{z}) = \frac{1}{2}(\Phi_e^\alpha - z^\alpha)^T \mu R_{\alpha}^{-1}(\Phi_e^\alpha - z^\alpha) + \frac{1}{2}(\tilde{z}^\beta)^T R_{\beta} \tilde{z}^\beta$, where

$$R_{\alpha} = \begin{bmatrix} R_{\alpha_1} & 0 & 0 \\ 0 & R_{\alpha_2} & 0 \\ 0 & 0 & R_{\alpha_3} \end{bmatrix}, \quad R_{\beta} = \begin{bmatrix} R_{\beta_1} & 0 & 0 \\ 0 & R_{\beta_2} & 0 \\ 0 & 0 & R_{\beta_3} \end{bmatrix}.$$

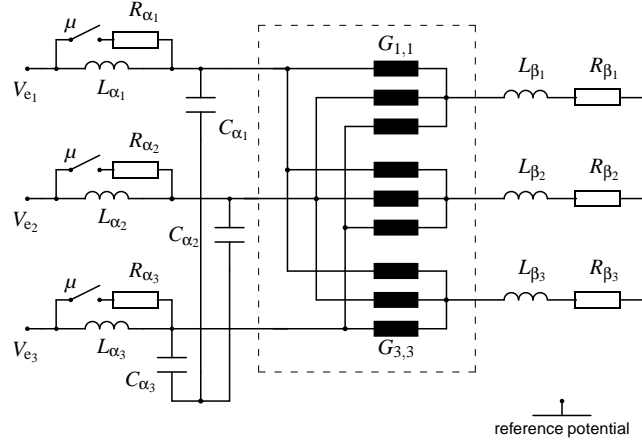

Figure 6: Example: 3×3 matrix converter with LC input filter, inductive output filter and switchable damping resistors.

The interconnection matrix A connecting the additional filter elements to the matrix converter is readily found as $A = \text{diag}(I_{d\alpha}, 0, 0)$, where $I_{d\alpha}$ denotes the $\alpha \times \alpha$ identity matrix. Hence, by using (12), the total mixed-potential representing the characteristic is of the converter is given by

$$P_{\text{tot}}(z, \tilde{z}) = \frac{1}{2}(z^\beta)^\top G_{\beta\beta}^{-1} z^\beta - \frac{1}{2}(z^\alpha)^\top [G_{\alpha\alpha} - G_{\beta\alpha}^\top G_{\beta\beta}^{-1} G_{\beta\alpha}] z^\alpha + (z^\beta)^\top G_{\beta\beta}^{-1} G_{\beta\alpha} z^\alpha + \frac{1}{2}(\Phi_e^\alpha - z^\alpha)^\top \mu R_\alpha^{-1} (\Phi_e^\alpha - z^\alpha) + \frac{1}{2}(\tilde{z}^\beta)^\top R_\beta \tilde{z}^\beta + (\tilde{z}^\alpha)^\top A z^\alpha. \quad (17)$$

If we for simplicity assume that the filter elements are linear and time-invariant, the matrices containing the filter element values are

$$C_\alpha = \begin{bmatrix} C_{\alpha_1} & 0 & 0 \\ 0 & C_{\alpha_2} & 0 \\ 0 & 0 & C_{\alpha_3} \end{bmatrix}, \quad L_\alpha = \begin{bmatrix} L_{\alpha_1} & 0 & 0 \\ 0 & L_{\alpha_2} & 0 \\ 0 & 0 & L_{\alpha_3} \end{bmatrix}, \quad L_\beta = \begin{bmatrix} L_{\beta_1} & 0 & 0 \\ 0 & L_{\beta_2} & 0 \\ 0 & 0 & L_{\beta_3} \end{bmatrix},$$

and thus the matrix Q_{tot} reads as

$$Q_{\text{tot}} = \begin{bmatrix} C_\alpha & 0 & 0 \\ 0 & -L_\beta & 0 \\ 0 & 0 & -L_\alpha \end{bmatrix}. \quad (18)$$

We now have all the information necessary to find the dynamic model of the matrix converter of Figure 6. The behavior is completely determined by the mixed-potential function found in (17). Finally, a state-space representation of the converter dynamics is obtained by substitution of (17) and (18) into (16).

4 Overall Stability and Passivity

In applications it is necessary to guarantee to be able to switch the converter from one state to the other in a reliable manner. For that reason, the LC filter elements are usually accompanied by passive resistors (see the example of Section 3) to rule out the possibility that during the switching process, the converter, and especially the input filter, may go into oscillation. The key motivation, as already briefly highlighted in Subsection 2.2.1 and 2.2.2, is that we can use the gradient system structure to find conditions on the filter element values of the converter which guarantee that the equilibrium set is (semi-)globally asymptotically stable. The strength of this method is that it also holds for circuits containing certain nonlinearities, like the switching itself, without having to linearize the dynamics first.

4.1 Stability Analysis

Due to space limitations, we will briefly discuss the application of the aforementioned analysis using the example of Section 3. The idea makes use of LaSalle's Invariance Theorem and Brouwer's Fixed-Point

Theorem, see e.g. [2], in conjunction with the gradient system form (16). Without loss of generality, we consider the case that $\hat{\Phi}_e = 0$. In that case, the time-derivative of the total mixed-potential $P_{\text{tot}}(\hat{z})$ is given by

$$\dot{P}_{\text{tot}}(\hat{z}) = -\dot{\hat{z}}^\top \frac{\partial P_{\text{tot}}}{\partial \hat{z}}(\hat{z}) = \dot{\hat{z}}^\top Q_{\text{tot}}(\hat{z}) \dot{\hat{z}}.$$

Unfortunately, we are not directly able to draw similar conclusions as in Subsection 2.2.1 or 2.2.2 due to the fact that the quadratic product $\dot{\hat{z}}^\top Q_{\text{tot}}(\hat{z}) \dot{\hat{z}}$ is sign indefinite. In order to overcome this problem we need to consider the following additional family of storage (Lyapunov) functions [2], of which its time-derivatives are also quadratic in $\dot{\hat{z}}$,

$$P_{\text{tot}}^*(\hat{z}) = \lambda P_{\text{tot}}(\hat{z}) + \frac{1}{2} \frac{\partial^\top P_{\text{tot}}}{\partial \hat{z}}(\hat{z}) M \frac{\partial P_{\text{tot}}}{\partial \hat{z}}(\hat{z}),$$

where $\lambda \in \mathbb{R}$ is a constant and M a symmetric matrix of appropriate dimensions. It is then checked by straightforward calculations that the time-derivative of this new storage function satisfies

$$\dot{P}_{\text{tot}}^*(\hat{z}) = \dot{\hat{z}}^\top Q_{\text{tot}}^*(\hat{z}) \dot{\hat{z}},$$

where $Q_{\text{tot}}^*(\hat{z})$ is a matrix defined as [9]

$$Q_{\text{tot}}^*(\hat{z}) = \left[\lambda + \frac{1}{2} \frac{\partial^2 P_{\text{tot}}}{\partial \hat{z}^2}(\hat{z}) M + \frac{1}{2} \frac{\partial}{\partial \hat{z}} \left(\frac{\partial P_{\text{tot}}}{\partial \hat{z}}(\hat{z}) M \right) \right] Q_{\text{tot}}(\hat{z}).$$

Finally, the problem of finding a storage function in the sense of LaSalle can be solved if we can find a λ and M such that the symmetric part of $Q_{\text{tot}}^*(\hat{z})$ is negative semi-definite, i.e.,

$$Q_{\text{tot}}^*(\hat{z}) + (Q_{\text{tot}}^*)^\top(\hat{z}) \leq 0. \quad (19)$$

In the following subsection we will apply the latter to the example discussed in Section 3 in order to find lower bounds on the damping resistors R_α .

Remark: Notice that $P_{\text{tot}}^*(\hat{z})$ and $Q_{\text{tot}}^*(\hat{z})$ also form an appropriate pair to describe the dynamics of the converter, i.e.,

$$[Q_{\text{tot}}^*(\hat{z})]^{-1} \frac{\partial P_{\text{tot}}^*}{\partial \hat{z}}(\hat{z}) \equiv Q_{\text{tot}}^{-1}(\hat{z}) \frac{\partial P_{\text{tot}}}{\partial \hat{z}}(\hat{z}) (= \dot{\hat{z}}).$$

4.2 Input Filter Design Example

Consider again the example matrix converter discussed in Section 3. In this subsection we will show that the stability analysis of the previous subsection can be used to determine a lower bound on the input filter damping resistors R_α to ensure a non-oscillatory response in case of, for example, setpoint changes. For simplicity, we will base our design on the three-to-one phase equivalent shown in Figure 7. Assume for the moment that the switches μ are closed, i.e., $\mu = 1$.

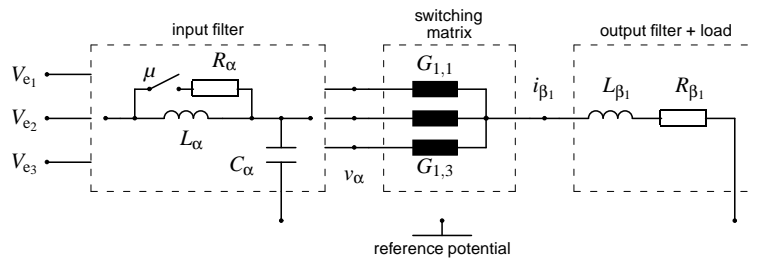

Figure 7: Example: 3×1 phase representation of the converter of Figure 6.

In [2] several mathematical methods are proposed to find the parameters λ and M such that inequality (19) is satisfied. For the converter under consideration, we state without proof that the inequality (19) is satisfied if R_α satisfies the inequality

$$R_{\alpha_k} > \sqrt{\frac{L_{\alpha_k}}{C_{\alpha_k}}}, \quad k = 1, 2, 3. \quad (20)$$

It is interesting to notice that this is precisely the design criterium one obtains when using classical input filter design methods like in [7]. Of course, the main advantage of the method shown here is that the stability criteria also hold for circuits with nonlinear filter elements.

5 Conclusion and Outlook

In this paper we have proposed a unified framework to model and analyze the dynamical behavior of a matrix converter with input and output filters. The method uses the classical Brayton-Moser equations and can be used to find conditions on the (possible nonlinear) filter elements in order to guarantee non-oscillatory responses in case of, for example, setpoint changes. Besides large signal stability analysis, the framework can also be used to design (passivity-based) controllers, e.g. [5, 9]. One of the main ideas presented in these references is that the dynamics of the system can be modified by shaping the mixed-potential function P , i.e., shaping the (reactive) power of the system, through the available control inputs. For the matrix converter structures considered in this paper shaping of the mixed-potential naturally involves the determination of the switching characteristics represented by the conductances $G_{j,k}$. As explained in [5], the stability criteria based on the Brayton-Moser framework helps us to find control actions in such a way that a non-oscillatory behavior is guaranteed, even if there are no damping resistors added to the dynamic filter elements, like the R_α 's in the example. For that, future research should be devoted on how to shape the mixed-potential function and how to determine the characteristics of the conductances $G_{j,k}$ in order to guarantee non-oscillatory dynamical behavior for all possible mode changes.

Selected References

- [1] A. Alesina, M.G.B. Venturini, "Solid-state power conversion: A Fourier analysis approach to generalized transformer synthesis", *IEEE Trans. Circ. Syst.*, Vol. 28, pp. 319-330, Apr. 1981.
- [2] R.K. Brayton and J.K. Moser, "A theory of nonlinear networks, part I", *Quart. Appl. Math.*, Vol. 12, No. 1, pp. 1-33, 1964.
- [3] D. Borojević, "Space vector modulation in matrix converters", *VPEC Current*, Vol. 5, no. 1, pp. 4-7, and no. 2, pp. 3-6, 1991.
- [4] D.G. Holmes and T.A. Lipo, "Implementation of a controlled rectifier using AC-AC matrix converter theory", *IEEE Trans. Power Elec.*, Vol. 7, No. 1, January 1992.
- [5] , D. Jeltsema and J. M. A. Scherpen, "Tuning rules for passivity-preserving controllers, In proc. American Control Conference, Angorage, Alaska, May 2002.
- [6] D. Jeltsema, R. Ortega and J.M.A. Scherpen, "On passivity and power-balance inequalities of nonlinear RLC circuits", to appear in *IEEE Trans. Circ. and Systems*. (Preliminary version available in Proc. 4th MathMod Conference, Vienna, Austria, Feb. 2003.)
- [7] R.D. Middelbrook, "Input filter considerations in design and application of switching regulators, Advances in Switch-Mode Power Conversion, Volumes I and II, 2nd edition, TESLAcO, 1983, paper 7, pp. 91-107.
- [8] M. Milanovič, B. Dobaj, "Unity input displacement factor correction principle for direct AC to AC matrix converters based on modulation strategy", *IEEE Tran. Circ. Syst.*, Vol. 47 pp. 221-230, February 2000.
- [9] R. Ortega, D. Jeltsema and J.M.A. Scherpen, 'Stabilization of nonlinear RLC circuits via power-shaping', in Proc. Latin American Conf. on Aut. Contr., Guadalajara, México, December 2002.
- [10] A.J. van der Schaft, *System Theoretic Description of Physical Systems*, CWI (Centrum voor Wiskunde en Informatica) Tract 3, 1984.
- [11] T.J. Sobczyk, "Control strategy of matrix converters", *Proc. EPE Brighton*, pp. 93-97, September 1993.
- [12] P. Tenti, L. Malesani and L. Rossetto, "Optimum control of N -input K -output matrix converters", *IEEE Trans. Power Elec.*, Vol. 7, No. 4, October 1992.
- [13] Various Authors, "A special issue on matrix converters", *IEEE Trans. Ind. Elect.*, Vol. 49, No. 4, April 2002.
- [14] P. Wood, *Switching Power Converters*, New York, NY: Van Nostrand, 1981.