

University of Groningen

Adaptive control of port-Hamiltonian systems

Dirksch, D.A.; Scherpen, J.M.A.

Published in:

Proceedings of the 19th International Symposium on Mathematical Theory of Networks and Systems

IMPORTANT NOTE: You are advised to consult the publisher's version (publisher's PDF) if you wish to cite from it. Please check the document version below.

Document Version

Publisher's PDF, also known as Version of record

Publication date:

2010

[Link to publication in University of Groningen/UMCG research database](#)

Citation for published version (APA):

Dirksch, D. A., & Scherpen, J. M. A. (2010). Adaptive control of port-Hamiltonian systems. In A. Edelmayer (Ed.), *Proceedings of the 19th International Symposium on Mathematical Theory of Networks and Systems* (pp. 1503-1508). University of Groningen, Research Institute of Technology and Management.

Copyright

Other than for strictly personal use, it is not permitted to download or to forward/distribute the text or part of it without the consent of the author(s) and/or copyright holder(s), unless the work is under an open content license (like Creative Commons).

The publication may also be distributed here under the terms of Article 25fa of the Dutch Copyright Act, indicated by the "Taverne" license. More information can be found on the University of Groningen website: <https://www.rug.nl/library/open-access/self-archiving-pure/taverne-amendment>.

Take-down policy

If you believe that this document breaches copyright please contact us providing details, and we will remove access to the work immediately and investigate your claim.

Downloaded from the University of Groningen/UMCG research database (Pure): <http://www.rug.nl/research/portal>. For technical reasons the number of authors shown on this cover page is limited to 10 maximum.

Adaptive control of port-Hamiltonian systems

D.A. Dirksz and J.M.A. Scherpen

Abstract—In this paper an adaptive control scheme is presented for general port-Hamiltonian systems. Adaptive control is used to compensate for control errors that are caused by unknown or uncertain parameter values of a system. The adaptive control is also combined with canonical transformation theory for port-Hamiltonian systems. This allows for the adaptive control to be applied on a large class of systems and for being included in the port-Hamiltonian framework.

I. INTRODUCTION

Adaptive control has proved to be a very useful method for controlling systems which are sensitive to parameter uncertainty. With adaptive control it is possible to estimate parameter errors and to compensate for those errors. This can improve the performance of the controlled system. In [11] some adaptive control methods were discussed which explicitly incorporate parameter estimation in the control law. Furthermore, basic adaptive control is described in [19] for linear, nonlinear, single-input and multi-input systems. The recursive methodology of backstepping is described in [8] for nonlinear and adaptive control design. Adaptive control for stabilization and tracking control of Euler-Lagrange (EL) systems was described in [12]. More recent results in the field of nonlinear applied adaptive control are presented in [1], which rely upon the the notions of *immersion and invariance*.

In this paper we want to describe an adaptive control scheme in the port-Hamiltonian (PH) framework. PH systems were introduced as a generalization of conventional systems [10]. They describe a large class of (nonlinear) systems including passive mechanical systems, electrical systems, electromechanical systems and mechanical systems with nonholonomic constraints [17]. In [4] canonical transformation was presented for PH systems. With canonical transformation a PH system can be transformed into another one while preserving the structure of the original system. The canonical transformation theory is interesting since it makes it possible to stabilize systems that cannot be stabilized by conventional state-feedback without canonical transformation. Some examples can be found in [3] and [5]. It has also been shown that the control methodologies Passivity-Based Control (PBC) and Interconnection and Damping Assignment Passivity-Based Control (IDA-PBC) are special cases of stabilization by canonical transformation.

For adaptive control of PH systems with uncertain parameters little is known. For PH systems [2] presented the use of an adaptive internal model to overcome sinusoidal

disturbances, but the system parameters were assumed to be known. In [20] simultaneous stabilization of PH systems was investigated. Here adaptive control was applied to deal with uncertain parameters. Although the results hold for general time-invariant PH systems, the assumptions limit the class of systems since a restriction is made on the form of the Hamiltonian.

Here we introduce an adaptive control scheme for general PH systems. The adaptive control compensates for input errors caused by not exactly knowing the value of the necessary system parameters. Compared to [20] we have weaker assumptions, deal with time-varying systems and the systems are not required to have the desired equilibrium point. Stabilization techniques can still be used to realize desired equilibrium points. It is also possible to extend the adaptive scheme to deal with a class of input disturbances. We will then use the general results to apply adaptive tracking control for fully actuated standard mechanical PH systems. The results are different than the well known Slotine-Li method [18], [19]

In the next section we briefly summarize canonical transformation and stabilization of PH systems. Since it is a general methodology which includes the PBC techniques it is an interesting method to determine the control input for PH systems. For this reason we choose stabilization by canonical transformation as control methodology and later on extend these results to realize adaptive control. In section III we introduce the problem of control with parameter uncertainty and present the PH adaptive control scheme. The adaptive control scheme is then applied on a special case in section IV, tracking control of fully actuated mechanical systems. Concluding remarks are given in section V.

Notation: To simplify expressions, the arguments of functions are left out if clear from the context. Furthermore, $\|\cdot\|$ denotes the Euclidean vector norm and $\|\cdot\|_p$ the \mathcal{L}_p -norm.

II. CANONICAL TRANSFORMATION AND STABILIZATION

Describe a nonautonomous PH system by

$$\begin{aligned} \dot{x} &= (J(x,t) - R(x,t)) \frac{\partial H}{\partial x}(x,t) + g(x,t)u \\ y &= g(x,t)^\top \frac{\partial H}{\partial x}(x,t) \end{aligned} \quad (1)$$

where $x = (x_1, \dots, x_n)^\top$ is the vector of system states, $J(x,t)$ is the skew symmetric interconnection matrix $J(x,t) \in \mathbb{R}^{n \times n}$, $R(x,t)$ a symmetric damping matrix $R(x,t) \in \mathbb{R}^{n \times n}$, $g(x,t)$ the input matrix $g(x,t) \in \mathbb{R}^{n \times l}$, $l \leq n$, u is the control input vector and y the output vector. The Hamiltonian $H(x,t)$ is defined as the sum of kinetic and potential energy of the system.

The authors are with the Faculty of Mathematics and Natural Sciences, University of Groningen, Nijenborgh 4, 9747 AG Groningen, The Netherlands. Email: d.a.dirksz@rug.nl, j.m.a.scherpen@rug.nl

Canonical transformation is widely used for analysis of the structure of dynamical systems in classical mechanics. In [4] canonical transformations for PH systems were introduced. There it was shown how PH systems are stabilized by using the canonical transformation. We now present the relevant results of [4] and [5].

Lemma 1: Consider the PH system described by (1). Suppose that $H(x, t)$ is positive definite, that $\frac{\partial H}{\partial t} \leq 0$ and that the system is zero-state detectable¹. Then the feedback $u = -C(x, t)y$ with $C(x, t) \geq \epsilon I > 0$ renders $x = 0$ globally asymptotically stable. \triangleleft

Lemma 2: The generalized Hamiltonian system (1) is transformed into another one by any time-invariant, non-singular, coordinate transformation. \triangleleft

Definition 1: A set of transformations

$$\bar{x} = \Phi(x, t) \quad (2)$$

$$\bar{H} = H(x, t) + U(x, t) \quad (3)$$

$$\bar{y} = y + \alpha(x, t) \quad (4)$$

$$\bar{u} = u + \beta(x, t) \quad (5)$$

that changes the coordinates x into \bar{x} , the Hamiltonian H into \bar{H} , the output y into \bar{y} and the input u into \bar{u} is said to be a generalized canonical transformation for the PH system if it transforms a PH system (1) into another. \triangleleft

The class of generalized canonical transformations are characterized by the following theorem:

Theorem 1: Consider the PH system described by (1). For any scalar function $U(x, t)$ and any vector function $\beta(x, t)$, there exists a pair of functions $\Phi(x, t)$ and $\alpha(x, t)$ that yields a generalized canonical transformation. The function $\Phi(x, t)$ yields a generalized canonical transformation with $U(x, t)$ and $\beta(x, t)$ if and only if there exist $K(x, t) = -K(x, t)^\top$ and $S(x, t) = S(x, t)^\top$ such that $R + S \geq 0$ and the partial differential equation (PDE)

$$\frac{\partial \Phi}{\partial(x, t)} \left((J - R) \frac{\partial U}{\partial x} + \begin{matrix} (K - S) \frac{\partial(H+U)}{\partial x} \\ -1 \end{matrix} + g\beta \right) = 0 \quad (6)$$

holds. The change of output $\alpha(x, t)$ and the matrices $\bar{J}(x, t)$, $\bar{g}(x, t)$ and $\bar{R}(x, t)$ are given by

$$\alpha = g^\top(x, t) \frac{\partial U}{\partial x}(x, t) \quad (7)$$

$$\bar{J} = \frac{\partial \Phi}{\partial x} (J + K) \frac{\partial \Phi}{\partial x}^\top \quad (8)$$

$$\bar{g} = \frac{\partial \Phi}{\partial x} g(x, t) \quad (9)$$

$$\bar{R} = \frac{\partial \Phi}{\partial x} (R + S) \frac{\partial \Phi}{\partial x}^\top \quad (10)$$

\triangleleft

¹A dynamical system with input u , output y and state x is said to be zero-state detectable if $(u, y) = (0, 0) \Rightarrow x \rightarrow 0$.

The result is that system (1) is transformed into the system

$$\begin{aligned} \dot{\bar{x}} &= (\bar{J}(\bar{x}, t) - \bar{R}(\bar{x}, t)) \frac{\partial \bar{H}}{\partial \bar{x}}(\bar{x}, t) + \bar{g}(\bar{x}, t) \bar{u} \\ \bar{y} &= \bar{g}(\bar{x}, t)^\top \frac{\partial \bar{H}}{\partial \bar{x}}(\bar{x}, t) \end{aligned} \quad (11)$$

Before describing the stabilization theorem the definition of decrescent is given, a concept used for stability analysis of nonautonomous systems.

Definition 2 ([7], [19]): A scalar function $W(x, t)$ is said to be decrescent if $W(0, t) = 0$ and if there exists a time-invariant positive definite function $W_1(x)$ such that

$$\forall t \geq 0, \quad W(x, t) \leq W_1(x)$$

\triangleleft

Theorem 2: Consider the PH system described by (1) and transform it by the generalized canonical transformation with $U(x, t)$ and $\beta(x, t)$ such that $H + U \geq 0$. Then the new input-output mapping $\bar{u} \mapsto \bar{y}$ is passive with storage function \bar{H} if and only if

$$\frac{\partial(H + U)^\top}{\partial(x, t)} \begin{pmatrix} (J - R) \frac{\partial U}{\partial x} - S \frac{\partial(H+U)}{\partial x} + g\beta \\ -1 \end{pmatrix} \geq 0 \quad (12)$$

Suppose that (12) holds, that $H + U$ is positive-definite and that the system is zero-state detectable. Then the feedback $u = -\beta - C(x, t)(y + \alpha)$ with $C(x, t) \geq \epsilon I > 0$ renders the point $\bar{x} = 0$ globally asymptotically stable. Suppose moreover that $H + U$ is decrescent and that the transformed system is periodic. Then the feedback renders the system uniformly asymptotically stable. \triangleleft

This section has summarized the theory of stabilization of PH system by canonical transformation. The theory was chosen because of the interesting properties of PH systems and because of dealing with general time-varying PH systems. This makes it applicable to tracking control problems. Furthermore, the method works even when a system cannot be stabilized by conventional state feedback without canonical transformation.

III. PARAMETER UNCERTAINTY AND ADAPTIVE CONTROL

Adaptive stabilization

In the previous section it was shown how canonical transformation is used to stabilize a PH system. However, the canonical transformation theory requires full information about the system. Not exactly knowing system parameters can result in a control input which does not lead to the desired behavior of the system. We can describe the control input signal u in terms of a nominal part (based on nominal system parameters) and an unknown part (based on the unknown errors in the parameters). We will make the following assumption.

A. 1: The control input u for system (1) can be expressed in terms of the unknown vector $z = (z_1, \dots, z_m)^\top$:

$$u = u_0(x, t) + \Delta(x, t)z \quad (13)$$

where $\Delta(x, t)$ is a matrix of known functions. \triangleleft

In (13) the input signal is expressed as the sum of a nominal input $u_0(x, t)$, the input based on the nominal parameters, and a term depending on the unknown vector z . The vector z is the vector of parameter errors; the vector containing the unknown differences between the real parameters of the system and the nominal parameters. The unknown term in (13) can then also be seen as the error in the required input signal. Theorem 2 showed that, when there is no uncertainty, a system can be asymptotically stabilized by the control input

$$u = -\beta(x, t) - C(x, t)(y + \alpha(x, t)) \quad (14)$$

In the case of parameter uncertainty we assume that (14) can be written in the form (13). Only applying the nominal input $u_0(x, t)$ to system (1), with

$$\bar{\Delta}(\bar{x}, t) = \Delta(\Phi^{-1}(\bar{x}, t), t) \quad (15)$$

$$= \Delta(x, t) \quad (16)$$

results in the transformed system

$$\begin{aligned} \dot{\bar{x}} &= \left(\bar{J}(\bar{x}, t) - \hat{R}(\bar{x}, t) \right) \frac{\partial \bar{H}}{\partial \bar{x}}(\bar{x}, t) - \bar{g}(\bar{x}, t) \bar{\Delta}(\bar{x}, t) z \\ \dot{\bar{y}} &= \bar{g}(\bar{x}, t)^\top \frac{\partial \bar{H}}{\partial \bar{x}}(\bar{x}, t) \end{aligned} \quad (17)$$

with

$$\hat{R}(\bar{x}, t) = \bar{R}(x, t) + \bar{g}(\bar{x}, t) C(\bar{x}, t) \bar{g}^\top(\bar{x}, t) \quad (18)$$

instead of the desired system (11) with $\bar{u} = -C(\bar{x}, t) \bar{y}$. It has already been mentioned that errors in the control input can cause the system to show undesired behavior. Adaptive control is here proposed to compensate for the errors in the control input, which are caused by errors in the parameter values.

Before giving our adaptive control theorem we recall Barbalat's lemma [7], [9], often used for analysis of nonautonomous systems.

Lemma 3 (Barbalat): Let $\varphi(t) : \mathbb{R} \rightarrow \mathbb{R}$ be a uniformly continuous function on $[0, \infty)$. Suppose that the limit of $\int_0^t \varphi(\tau) d\tau$ as t tends to infinity exists and is finite. Then,

$$\lim_{t \rightarrow \infty} \varphi(t) = 0 \quad (19)$$

\triangleleft

Theorem 3: Consider system (1) for which the parameter values are uncertain. Assume that assumption A.1 holds. Assume furthermore that

A. 2: There exist a scalar function $U(x, t)$ and a vector function $\beta(x, t)$ such that (6) and (12) hold and $H + U$ is positive definite.

A. 3: The Hamiltonian of the transformed system $\bar{H}(\bar{x}, t)$ can be described in terms of kinetic and potential energy, i.e.,

$$\bar{H}(\bar{x}, t) = \bar{T}(\bar{x}, t) + \bar{V}(\bar{x}) \quad (20)$$

with $\bar{T}(\bar{x}, t)$ and $\bar{V}(\bar{x})$ the kinetic and potential energy of the transformed system, respectively.

A. 4: For the kinetic energy $\bar{T}(\bar{x}, t)$ we have

$$\lim_{\bar{y} \rightarrow 0} \bar{T}(\bar{x}, t) = 0 \quad (21)$$

A. 5: The limit

$$\lim_{t \rightarrow \infty} \|\Delta(x, t)\| \quad (22)$$

does not exist. That is, $\Delta(x, t)$ stays non-constant as $t \rightarrow \infty$.

A. 6: The system is zero-state detectable and \bar{y} can be measured.

Then, the control input

$$u = u_0(x, t) + \Delta(x, t) \hat{z} \quad (23)$$

with $C(x, t) \geq \epsilon I > 0$, \hat{z} the estimate of z and adaptation law

$$\dot{\hat{z}} = -K_a \Delta^\top(x, t) \bar{y} \quad (24)$$

with K_a a diagonal positive definite matrix renders the system (1) globally asymptotically stable in $\bar{x} = 0$.

Proof. Define the parameter estimation error by $\bar{z} = \hat{z} - z$. The closed-loop system realized by input (23) and adaptation law (24) can be described in PH form ²

$$\begin{bmatrix} \dot{\bar{x}} \\ \dot{\bar{z}} \end{bmatrix} = \begin{bmatrix} \bar{J} - (\bar{R} + \bar{g}C\bar{g}^\top) & \bar{g}\bar{\Delta}K_a \\ -K_a\bar{\Delta}^\top\bar{g}^\top & 0 \end{bmatrix} \begin{bmatrix} \frac{\partial \mathcal{H}}{\partial \bar{x}} \\ \frac{\partial \mathcal{H}}{\partial \bar{z}} \end{bmatrix} \quad (25)$$

$$\bar{y} = \bar{g}^\top \frac{\partial \mathcal{H}}{\partial \bar{x}}$$

where the arguments have been left out for notational simplicity, with the Hamiltonian

$$\mathcal{H} = \bar{H}(\bar{x}, t) + \frac{1}{2} \bar{z}^\top K_a^{-1} \bar{z} \quad (26)$$

Take (26) as Lyapunov candidate function. Then

$$\begin{aligned} \dot{\mathcal{H}} &\leq -\bar{y}^\top C \bar{y} \\ &\leq -\epsilon \|\bar{y}(t)\|^2 \end{aligned} \quad (27)$$

with ϵ a positive constant. The Lyapunov candidate function (26) is lower bounded and application of Barbalat's lemma, lemma 3, with $\varphi = \dot{\mathcal{H}}$ indicates that $\bar{y} \rightarrow 0$ as time $t \rightarrow \infty$. Since $\dot{\mathcal{H}} \rightarrow 0$ the function (26) becomes constant. Assumption A.4 then implies that the kinetic energy $\bar{T}(\bar{x}, t)$ goes to zero as $t \rightarrow \infty$. Since (26) can be written in the form

$$\mathcal{H} = \bar{T}(\bar{x}, t) + \bar{V}(\bar{x}) + \frac{1}{2} \bar{z}^\top K_a^{-1} \bar{z} \quad (28)$$

\bar{x} and \bar{z} become constant. The closed-loop dynamics of (25) can then be reduced to

$$\dot{\bar{x}} = [\bar{J} - (\bar{R} + \bar{g}C\bar{g}^\top)] \frac{\partial \mathcal{H}}{\partial \bar{x}} + \bar{g}\bar{\Delta}\bar{z} \quad (29)$$

Since \bar{x} becomes constant we have that $\dot{\bar{x}} = 0$ as $t \rightarrow \infty$. The matrix $\bar{\Delta}$ is non-constant so $\bar{z} \rightarrow 0$ else we have that $\dot{\bar{x}} \neq 0$. Since $\bar{z} \rightarrow 0$ the zero-state detectability assumption with (29) and $\bar{y} \rightarrow 0$ implies that $\bar{x} \rightarrow 0$ as $t \rightarrow \infty$. \square

²Since z is constant $\dot{\hat{z}} = \dot{\bar{z}}$.

Remark 1: If the function (26) is decrescent, by theorem 2 uniform asymptotic stability can then be claimed for system (1). \square

Theorem 3 shows how adaptive control can be realized in the PH framework, for general nonautonomous PH systems. It should be noted that assumptions A.3 and A.4 hold for a large class of physical PH systems. The update law for \hat{z} follows from requiring that the interconnection matrix of the closed-loop system (transformed system with estimator) to be skew-symmetric. Assumption A.5 can limit the application for stabilization problems. However, as will be shown in the next section, it can be applied for tracking problems. We also want to remark that theorem 3 can be extended to deal with input disturbances. Any input disturbance described by a linear combination of an unknown constant term and a known function, which stays non-constant, can be canceled by applying adaptive control to estimate the unknown term.

Example: vibration isolation

Figure 1 shows a mass-spring-damper (MSD) system with

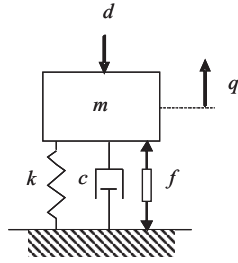

Fig. 1. Mass-spring-damper system.

mass $m > 0$, $k > 0$ the positive spring constant, $c > 0$ the damping constant, input force f and (input) disturbance

$$d(t) = A \sin(\omega t + \phi) \quad (30)$$

with A, ω, ϕ positive constants. Describe a standard mechanical system in PH form by

$$\begin{bmatrix} \dot{q} \\ \dot{p} \end{bmatrix} = \begin{bmatrix} 0 & I \\ -I & -D(q, p) \end{bmatrix} \begin{bmatrix} \frac{\partial H}{\partial q} \\ \frac{\partial H}{\partial p} \end{bmatrix} + \begin{bmatrix} 0 \\ G \end{bmatrix} u \quad (31)$$

$$y = G^\top \frac{\partial H}{\partial p}$$

with $q = (q_1, \dots, q_k)^\top$ the vector of generalized configuration coordinates, $p = (p_1, \dots, p_k)^\top$ the vector of generalized momenta, I the identity matrix, $D(q, p) \in \mathbb{R}^{k \times k}$ the (positive definite) damping matrix, G the input matrix and y the output vector. The Hamiltonian of the system is equal to the sum of kinetic and potential energy:

$$H(q, p) = \frac{1}{2} p^\top M^{-1}(q) p + V(q) \quad (32)$$

where $M(q) = M^\top(q) > 0$ is the system mass matrix and $V(q)$ the potential energy. For fully actuated systems the input matrix can be taken, without loss of generality, equal to the identity matrix, $G = I$. In [16] it is shown how sensitive equipment supported by a vibrating structure can

be modeled as a MSD system. The objective in designing an active isolation system is to add a force actuator working in parallel with the spring and dashpot, similar to figure 1. Taking the suspension frame of a wafer stepper/scanner as example, the force f will be supplied by a piezo actuator. It is well known that piezo material exhibits hysteresis effects. In [19] it is explained how hysteresis can cause self-sustained oscillations, which can be approximated as a sinusoidal disturbance with a known base frequency. This can simplify both modeling and control design of a system with a complex nonlinearity like hysteresis.

Assume that ω is known, but A and ϕ are not. It is possible to re-write the disturbance d in the form

$$\begin{aligned} A \sin(\omega t + \phi) &= A (\sin(\omega t) \cos(\phi) + \cos(\omega t) \sin(\phi)) \\ &= \underbrace{A \cos(\phi)}_{z_1} \sin(\omega t) + \underbrace{A \sin(\phi)}_{z_2} \cos(\omega t) \end{aligned}$$

The adaptive control scheme can be applied to estimate z_1 and z_2 , since the matrix $\Delta(x, t)$ will not be constant (because of the sine and cosine functions). For this example canonical transformation is not necessary. For the simulation we take $m = 1, k = 20, c = 10, A = 1, \omega = 1$ and $\phi = 0$. For the adaptive control we take $K_z = 100$, with a nominal value of zero for A . Figure 2 shows simulation results for how PH adaptive control stabilizes the system and the estimation of the disturbance amplitude converges to A .

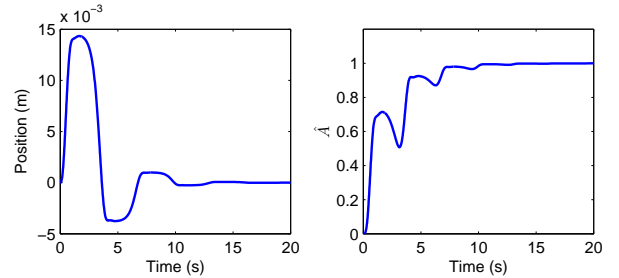

Fig. 2. Trajectories for the MSD system under sinusoidal disturbance and adaptive control. Initial conditions: $[q(0) \ p(0) \ \hat{A}(0)] = [0 \ 0 \ 0]$

Although simple, the example is also interesting because an equivalent RLC electrical network can be described. This can be thought of a RLC network where the source has a disturbance of known frequency, but unknown amplitude and phase.

In the next section we apply the presented adaptive control scheme to tracking control of standard fully-actuated mechanical systems.

IV. TRACKING CONTROL OF FULLY ACTUATED MECHANICAL SYSTEMS

Adaptive tracking control

The example in the previous section did not require coordinate transformation, i.e., $\bar{x} = x$. Here, we apply theorem 3 to realize adaptive tracking control of fully-actuated standard mechanical systems, described by (31). In the introduction it was already mentioned that tracking is

realized by transforming the system into an error system, which is then asymptotically stabilized. Transformation of a fully actuated standard mechanical system into an error system by canonical transformation was shown in [5], with $(\bar{q}, \bar{p})^\top = \Phi(q, p, t)$:

$$\bar{q} = q - q_d(t) \quad (33)$$

$$\bar{p} = p - M(q)\dot{q}_d(t) \quad (34)$$

and $q_d(t)$ the desired trajectory which is assumed to be known and twice differentiable. Theorem 3 extends the results of [5] to realize adaptive tracking control, under the assumptions

A. 7: The desired trajectory $q_d(t) \in \mathcal{C}^2$ is assumed to be known, non-constant in infinity and

$$\|q_d(t)\|, \|\dot{q}_d(t)\|, \|\ddot{q}_d(t)\| < B \quad (35)$$

with B a positive constant. \triangleleft

A. 8: The mass matrix $M(q)$, the damping matrix $D(q, p)$ and the potential energy term $\rho(q)$ can be expressed in terms of unknown real parameters z_1, \dots, z_m :

$$\begin{aligned} M(q) &= \sum_{i=1}^m M_i(q)z_i + M_0(q) \\ D(q, p) &= \sum_{i=1}^m D_i(q, p)z_i + D_0(q, p) \\ \rho(q) &= \sum_{i=1}^m \rho_i(q)z_i + \rho_0(q) \end{aligned} \quad (36)$$

Remark 2: We want to remark that assumptions A.7 and A.8 are not extra assumptions for application of theorem 3. They are assumptions made for the specific class of standard mechanical systems such that assumptions A.1 and A.5 in theorem 3 are satisfied. \triangleleft

For tracking control a non-constant $\Delta(x, t)$, assumption A.5, can be assured since for a desired trajectory the changes in the desired positions will cause a change in the desired velocities and accelerations. However, the method cannot be assured to work for stabilization since convergence of velocities to zero may still result in a steady-state error. Remember that the adaptation law is driven by the velocity errors.

In the literature about adaptive tracking control of fully actuated mechanical systems [6], [11], [12], [15], [18] and [19], to name a few, the error signal is usually redefined. The method proposed in this paper does not require such a definition of the error signal. The adaptive input, which compensates for errors, together with the skew-symmetry of the interconnection matrix of the error system directly results in the adaptation law for the uncertain parameters and passivity of the error system. It is also interesting to note that the error system resulting from the canonical transformation [5] and the error system with adaptation given in this paper are both PH. The (adaptive) tracking results for EL systems

[12],[19], also give a passive error system, however, the resulting error system is not of EL form anymore, and is thus not so easy to analyze.

Example: 2R planar manipulator

The adaptive tracking control is applied on a fully actuated 2 DOF planar manipulator (2R planar manipulator). The system is shown in figure 3. The manipulator has links with

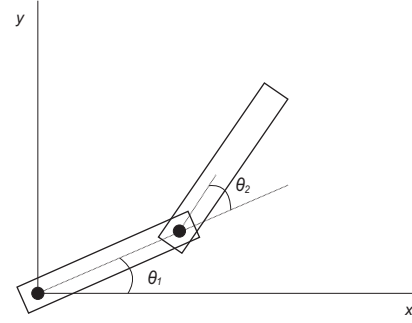

Fig. 3. 2R planar manipulator.

length l_i , angles θ_i , mass m_i , the center of the mass is denoted by r_i and the moment of inertia I_i with $i = 1, 2$.

The system works in the horizontal plane so gravity influence can be neglected. The Hamiltonian can then be defined by only kinetic energy:

$$H(q, p) = \frac{1}{2}p^\top M^{-1}(q)p \quad (37)$$

with $q = (\theta_1, \theta_2)^\top$ and $p = M(q)\dot{q}$. Define the constants

$$\begin{aligned} a_1 &= m_1 r_1^2 + m_2 l_1^2 + I_1 \\ a_2 &= m_2 r_2^2 + I_2 \\ b &= m_2 l_1 r_2 \end{aligned}$$

The mass/inertia matrix becomes

$$M(q) = \begin{bmatrix} a_1 + a_2 + 2b \cos \theta_2 & a_2 + b \cos \theta_2 \\ a_2 + b \cos \theta_2 & a_2 \end{bmatrix} \quad (38)$$

The system is fully actuated with input signal $u = (u_1, u_2)$, which are the control torques on the two joints. The damping matrix is assumed to be constant, $D = \text{diag}\{d_1, d_2\}$. For simplicity the system parameters are chosen to be all equal to one. Furthermore we have $K_p = \text{diag}\{20, 20\}$ and $K_d = \text{diag}\{10, 10\}$, where K_p is the matrix of controller gains and K_d the matrix of the additional (injected) damping constants. The desired joint angles are

$$q_{1d}(t) = \theta_{1d}(t) = c_1 \sin \omega_1 t \quad (39)$$

$$q_{2d}(t) = \theta_{2d}(t) = c_2 \sin \omega_2 t \quad (40)$$

where $c_1 = c_2 = \omega_1 = \omega_2 = 1$. It is assumed that the values of the masses m_1, m_2 and the values of the damping matrix d_1, d_2 are uncertain/unknown. Table I shows the nominal and real values used in this example. Figure 4 shows the trajectories for the manipulator and figure 5 the estimation of the uncertain parameter values. It can be seen that the tracking errors converge to zero and that the estimation of

TABLE I
UNCERTAIN PARAMETER VALUES

Parameter	Nominal	Real
m_1	1.2	1
m_2	1.2	1
d_1	0	1
d_2	0	1

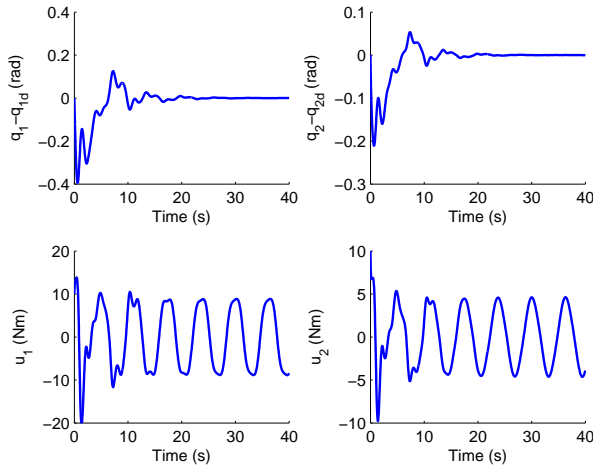

Fig. 4. Error trajectories for the 2R planar manipulator with uncertainty and adaptive control. Initial conditions: $[q(0) \ p(0)] = [0 \ 0 \ 0 \ 0]$.

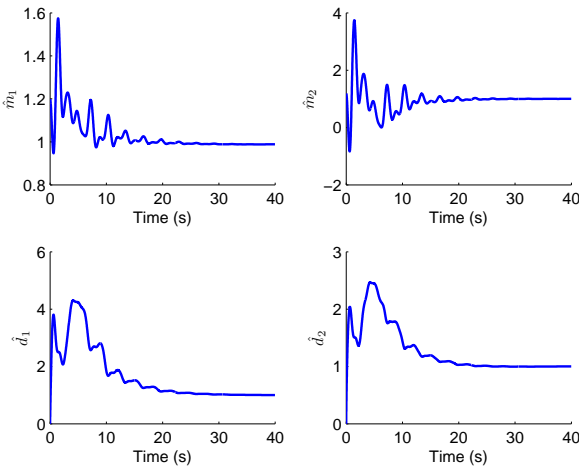

Fig. 5. Estimation of uncertain parameters.

the parameter values converge to the real values. It should be pointed out that figure 5 does not show the trajectories of \hat{z} , but of \hat{z} plus the nominal parameter values (given in table I).

V. CONCLUDING REMARKS

In this paper adaptive control of general PH systems was presented. The adaptive control scheme was combined with

canonical transformation theory for PH systems. This allows the adaptive control scheme to be applied on a large class of systems and for being included in the PH framework. The advantages are the insightful PH structure.

Two examples were used to show the application of the PH adaptive control scheme. The results showed how the adaptive control estimates and compensates for the errors of the uncertain parameters such that trajectories converge to the desired trajectories. It is obvious that with more unknown parameters there are more parameters which have to be estimated. This can be expected to take more time and so the speed of convergence of the tracking error decreases.

REFERENCES

- [1] A. Astolfi, D. Karagiannis, R. Ortega, 2008, Towards applied nonlinear adaptive control, *Annual Reviews in Control*, Vol. 32, No. 2, 136-148
- [2] C. Bonivento, L. Gentili, A. Paoli, 2004, Internal model based fault tolerant control of a robot manipulator, *Proceedings IEEE Conference on Decision and Control*, Atlantis, Bahamas
- [3] K. Fujimoto, T. Sugie, 2000, Time-varying stabilization of nonholonomic Hamiltonian systems via canonical transformations, *Proceedings of American Control Conference*, Chicago, USA
- [4] K. Fujimoto, T. Sugie, 2001, Canonical transformation and stabilization of generalized Hamiltonian systems, *Systems & Control Letters*, Vol. 42, No. 3, 217-227
- [5] K. Fujimoto, K. Sakurama, T. Sugie, 2003, Trajectory tracking of port-controlled Hamiltonian systems via generalized canonical transformations, *Automatica*, Vol. 39, No. 12, 2059-2069
- [6] B. Jayawardhana, G. Weiss, 2009, Tracking and disturbance rejection for fully actuated mechanical systems, *Automatica*, Vol. 44, No. 12, 3036-3045
- [7] H. Khalil, 1996, *Nonlinear Systems*, Prentice Hall, Upper Saddle River
- [8] M. Krstic, I. Kanellakopoulos, P. Kokotovic, 1995, *Nonlinear and Adaptive Control Design*, John Wiley & Sons, New York
- [9] R. Marino, P. Tomei, 1995, *Nonlinear Control Design, Geometric, Adaptive and Robust*, London, Prentice Hall
- [10] B.M. Maschke, A.J. van der Schaft, 1992, Port-controlled Hamiltonian systems: modeling origins and system-theoretic properties, *IFAC symposium on Nonlinear Control Systems*, Bordeaux, France, 282-288
- [11] R. Ortega, M.W. Spong, 1989, Adaptive motion control of rigid robots: a tutorial, *Automatica*, Vol. 25, No. 6, 877-888
- [12] R. Ortega, A. Loria, P.J. Nicklasson, H. Sira-Ramírez, 1998, *Passivity-based control of Euler-Lagrange systems: mechanical, electrical and electromechanical applications*, London, Springer
- [13] R. Ortega, A. van der Schaft, B. Maschke, G. Escobar, 2002, Interconnection and damping assignment passivity-based control of port-controlled Hamiltonian systems, *Automatica*, Vol. 38, 585-596
- [14] R. Ortega, M. Spong, F. Gomez and G. Blankenstein, 2002, Stabilization of underactuated mechanical systems via interconnection and damping assignment, *IEEE Transactions on Automatic Control*, Vol. 47, No. 8, 1218 - 1233
- [15] E. Panteley, R. Ortega, M. Gäfvert, 1998, An adaptive friction compensator for global tracking in robot manipulators, *Systems & Control Letters*, Vol. 33, No. 5, 307-313
- [16] A. Preumont, 2002, *Vibration control of active structures, an introduction*, New York, Kluwer Academic Publishers
- [17] A.J. van der Schaft, 2000, *L2-gain and passivity techniques in nonlinear control*, London, Springer
- [18] J.J.E. Slotine, W. Li, 1988, Adaptive manipulator control: A case study, *IEEE Transactions on Automatic Control*, Vol. 33, No. 11, 995-1003
- [19] J.J.E. Slotine, W. Li, 1991, *Applied Nonlinear Control*, Prentice Hall, New Jersey
- [20] Y. Wang, G. Feng, D. Cheng, 2007, Simultaneous stabilization of a set of nonlinear port-controlled Hamiltonian systems, *Automatica*, Vol. 43, No. 3, 403-415