

University of Groningen

## Sulfur Nutrition and Sulfur Assimilation in Higher Plants

Rennenberg, H.; Brunold, C.; De Kok, L. J.; Stulen, I.

**IMPORTANT NOTE: You are advised to consult the publisher's version (publisher's PDF) if you wish to cite from it. Please check the document version below.**

*Document Version*

Publisher's PDF, also known as Version of record

*Publication date:*

1990

[Link to publication in University of Groningen/UMCG research database](#)

*Citation for published version (APA):*

Rennenberg, H. (Ed.), Brunold, C. (Ed.), De Kok, L. J., & Stulen, I. (1990). *Sulfur Nutrition and Sulfur Assimilation in Higher Plants: Fundamental Environmental and Agricultural Aspects*. SPB Academic Publishing.

### Copyright

Other than for strictly personal use, it is not permitted to download or to forward/distribute the text or part of it without the consent of the author(s) and/or copyright holder(s), unless the work is under an open content license (like Creative Commons).

The publication may also be distributed here under the terms of Article 25fa of the Dutch Copyright Act, indicated by the "Taverne" license. More information can be found on the University of Groningen website: <https://www.rug.nl/library/open-access/self-archiving-pure/taverne-amendment>.

### Take-down policy

If you believe that this document breaches copyright please contact us providing details, and we will remove access to the work immediately and investigate your claim.

*Downloaded from the University of Groningen/UMCG research database (Pure): <http://www.rug.nl/research/portal>. For technical reasons the number of authors shown on this cover page is limited to 10 maximum.*

Sulfur  
nutrition  
and  
sulfur  
assimilation

in  
higher  
plants

fundamental  
environmental  
and agricultural  
aspects



editors: H. RENNENBERG CH. BRUNOLD L.J. DEKOK I. STULEN

SPB Academic Publishing

# Sulfur nutrition and sulfur assimilation in higher plants

Fundamental  
environmental  
and agricultural  
aspects

Proceedings of a workshop organized by the Department of Plant  
Physiology, University of Groningen. The Fraunhofer Institute for  
Atmospheric Environmental Research, and the Institute of Plant  
Physiology, University of Bern Haren, 28-31 March 1989

Edited by

H. RENNENBERG  
Fraunhofer Institute for Atmospheric  
Environmental Research, Garmisch-  
Partenkirchen, Fed. Rep. Germany

C. BRUNOLD  
Institute of Plant Physiology,  
University of Bern  
Bern, Switzerland

and  
L.J. DE KOK  
I. STULEN  
Department of Plant Physiology,  
University of Groningen.  
Haren, the Netherlands



SPB Academic Publishing

CIP-DATA KONINKLIJKE BIBLIOTHEEK, DEN HAAG

**Sulfur**

Sulfur nutrition and sulfur assimilation in higher plants  
: proceedings of the Workshop Sulfur Metabolism, Haren,  
The Netherlands, March 28–31, 1989 / ed. by H. Rennenberg  
... [et al.]. – The Hague : SPB Academic Publishing. – Ill.  
With index.

ISBN 90-5103-038-X

SISO 583 UDC 581.13

Subject headings: sulfur nutrition ; plants / sulfur  
assimilation ; plants.

© 1990 SPB Academic Publishing bv, P.O. Box 97747  
2509 GC The Hague, The Netherlands

All rights reserved. No part of this book may be translated or reproduced in any form by  
print, photoprint, microfilm, or any other means without the prior written permission of the  
publisher.

ISBN 90-5103-038-X

# CONTENTS

Preface	vii
Foreword	ix
<b>Section 1. Regulatory aspects of uptake and reduction of sulfate and incorporation into amino acids</b>	
1.1 W.J. Cram, Uptake and transport of sulfate	3
1.2 C. Brunold, Reduction of sulfate to sulfide	13
1.3 J. Giovanelli, Regulatory aspects of cysteine and methionine synthesis	33
1.4 Discussion	49
<b>Section 2. Metabolism of sulfur into organic sulfur compounds</b>	
2.1 H. Rennenberg and G.L. Lamoureux, Physiological processes that modulate the concentration of glutathione in plant cells	53
2.2 M. Kreis, Synthesis, structure and evolutionary relationships of sulfur-rich seed proteins in higher plants	67
2.3 K.F. Kleppinger-Sparace, S.A. Sparace and J.B. Mudd, Plant sulfolipids	77
2.4 E. Grill, E.-L. Winnacker and M.H. Zenk, Phytochelatins, the heavy metal binding peptides of the plant kingdom	89
2.5 E. Schnug, Glucosinolates – fundamental, environmental and agricultural aspects	97
2.6 Discussion	107
<b>Section 3. Environmental and agricultural aspects of sulfur metabolism</b>	
3.1 L.J. De Kok, Sulfur metabolism in plants exposed to atmospheric sulfur	111
3.2 W.H.O. Ernst, Ecological aspects of sulfur metabolism	131
3.3 J.F. Thompson and J.T. Madison, The effect of sulfate and methionine on legume proteins	145
3.4 Discussion	159
<b>Poster Contributions</b>	
4.1 C.I. Bell, W.J. Cram and D.T. Clarkson, Turnover of sulfate in leaf vacuoles limits retranslocation under sulfur stress	163
4.2 L. Bergmann and R. Hell, Determination and characterization of $\gamma$ -glutamylcysteine synthetase from higher plants	167
4.3 W. Bosma, G. Kamminga and L.J. De Kok, $H_2S$ -induced accumulation of sulfhydryl-compounds in leaves of plants under field and laboratory exposure	173
4.4 K.-J. Dietz and H. Busch, Intracellular compartmentation, utilization and transport of methionine in barley mesophyll cells	177

4.5	G. Ferrari, G. Cacco, A. Bottacin and M. Saccomani, Energetics of sulfate uptake by plants as related to previous sulfate availability	181
4.6	P.B. Goldsbrough, M.L. Mendum and S.C. Gupta, Effect of glutathione on phytochelatin synthesis and cadmium tolerance in tomato cells	185
4.7	D. Grill, H. Guttenberger and E. Bermadinger, Thiol-content of plants depending on the altitude	191
4.8	A.S. Gupta, R.G. Alscher and D.C. McCune, Ozone exposure, glutathione levels and photosynthesis in hybrid poplar	195
4.9	S. Klapheck, I. Zimmer and H. Cosse, Glutathione and ascorbate participate in hydrogen peroxide degradation in germinating castor bean endosperm	199
4.10	K.F. Kleppinger-Sparace, J.B. Mudd and S.A. Sparace, Biosynthesis of plant sulfolipids	205
4.11	F.A. Krone, C. Mundt and J.D. Schwenn, Probing for PAPS-reductase in higher organisms by Southern blotting of genomic DNA with the cloned <i>cysH</i> gene from <i>Escherichia coli</i>	209
4.12	Karuna C. Lakkineni, T.V.R. Nair and Y.P. Abrol, S and N interaction in relation to H <sub>2</sub> S emission in some crop species	213
4.13	G.L. Lamoureux, E.P. Fuerst and D.G. Rusness, Selected aspects of glutathione conjugation research in herbicide metabolism and selectivity	217
4.14	K. Nagel, Physiological aspects of Cd-tolerance in <i>Chlamydomonas reinhardtii</i>	223
4.15	H. Pfanz, K.-J. Dietz, I. Weinerth and B. Oppmann, Detoxification of sulfur dioxide by apoplastic peroxidases	229
4.16	N.J. Robinson, E. Delhaize, W.P. Lindsay, J.M. Berger and P.J. Jackson, Regulation of poly( $\gamma$ -glutamylcysteinyl)glycine synthesis in <i>Datura innoxia</i> cell cultures	235
4.17	D. Schmutz, A. Rügsegger and C. Brunold, Effects of heavy metals on assimilatory sulfate reduction in pea roots	241
4.18	P. Schröder, D.G. Rusness and G.L. Lamoureux, Detoxification of xenobiotics in spruce trees is mediated by glutathione-S-transferases	245
4.19	R. Schupp and H. Rennenberg, Diurnal changes in the thiol composition of spruce needles	249
4.20	J.A.C. Verkleij, P.L.M. Koevoets, J. van't Riet, J.A. de Knecht and W.H.O. Ernst, The role of metal-binding compounds (phytochelatins) in the cadmium-tolerance mechanism of bladder campion ( <i>Silene vulgaris</i> )	255
4.21	T.L. Vierheller and I.K. Smith, Effect of chilling on glutathione reductase and total glutathione in soybean leaves ( <i>Glycine max</i> (L) Merr)	261
	Acknowledgements	267
	Workshop participants	268
	Index of authors	270
	Subject index	271

## **PREFACE**

This book summarizes the present understanding of sulfur uptake, assimilation and metabolism in higher plants. At the same time it indicates essential gaps in our knowledge in these fields, and raises questions which will hopefully contribute in inducing research aimed at finding appropriate answers.

In our view the book is unique in its attempt to include all aspects of sulfur metabolism, from molecular biology, biochemistry and physiology to ecology and agriculture. It discusses the formation and metabolism of all major sulfur containing products of higher plants, including sulfolipids, glutathione, glycosinolates, phytochelatins and proteins. The book contains the contributions presented at the first Workshop on Sulfur Metabolism in Higher Plants, held in Haren, the Netherlands, from March 28 to 31, 1989. This workshop was organized by the Fraunhofer Institute for Atmospheric Environmental Research, the University of Bern and the University of Groningen. The first part of the book contains invited papers of general interest for all plant physiologists. The second part, which represents the posters shown at the workshop, addresses the specialists in particular.

We are glad to dedicate this book to J. A. Schiff, Brandeis University, Massachusetts, U.S.A., a pioneer in the research of sulfur metabolism. His first publication in this field dates back to 1956, and he still continues to publish most exciting papers. With our dedication we want to acknowledge the important contribution of J. A. Schiff for more than three decades.

Heinz Rennenberg  
Christian Brunold  
Luit J. De Kok  
Ineke Stulen

*editors*



Jerome A. Schiff



## FOREWORD

### Comments on Organellar Sulfate Metabolism

Jerome A. Schiff

I wish to thank the organizers and editors for their kind dedication of this distinguished volume containing many important contributions to the advancement of our knowledge of sulfur metabolism. Brimstone biochemistry has been a rather small special field for special people who are stubborn and have enough curiosity to put up with difficulties. The high reactivity of sulfur, for example, continually forces us to rule out artifacts in order to discover the underlying metabolic reactions. Fortunately, none of us has had to face the problems of Baumann and Fromm who had to abandon their work with thioacetone because of the protests of the citizens of Freiburg who found the odor obnoxious (Noller, 1952). Still, we press on and my many collaborators (see the bibliography and the reviews therein) and I are proud to acknowledge membership in such a determined and talented company.

Perhaps it would be most useful given the aims of the present volume to continue on in a direction that will not be explored in detail elsewhere but has engaged our interest recently, the area concerned with the intracellular localization of sulfate metabolism. Through the earlier work of Schmidt, Schwenn and Trebst (see Schiff, 1983) we know that the reactions of sulfate activation and reduction in spinach are found in the chloroplast. However, the work of Brunold (Brunold and Schiff, 1976) with *Euglena* established for the first time that the enzymes of sulfate reduction between adenosine 5' phosphosulfate (APS) and cysteine can be found in the mitochondria, and, as in other photosynthetic eukaryotes, that the process begins with a sulfotransferase specific for APS. Later work (Saida *et al.*, 1985) showed that the sulfate activating enzymes leading to the formation of APS and adenosine 3' phosphate 5' phosphosulfate (PAPS) are located on the outside of the inner mitochondrial membrane (i.e. on the outside of the mitoplast) and that the PAPS formed from sulfate appears in the surrounding medium. Still more recently (Saida *et al.*, 1988) we have shown that sulfate reduction leading to the formation of cysteine is found in the same location. Thus there appears to be a sulfate-metabolizing center on the outside of the mitochondrial inner membrane in *Euglena* and this center is supplied with ATP from oxidative phosphorylation (Saida *et al.*, 1988). As with PAPS, most of the cysteine formed is found in the surrounding medium; a small amount enters the mitoplast and is incorporated into protein. The sulfate activating enzymes appear to be absent from *Euglena* chloroplasts (Saida *et al.*, 1988) and the chloroplasts do not convert sulfate to other compounds.

Where, then, does the sulfonic group of the *Euglena* chloroplast sulfolipid come from? The presence of a plastid is necessary for sulfolipid formation since *Euglena* mutant W<sub>10</sub> which lacks plastids completely (Osafune and Schiff, 1983) does not form detectable sulfolipid. Isolated *Euglena* chloroplasts incubated with <sup>35</sup>SO<sub>4</sub><sup>2-</sup>, however, do not form labeled sulfolipid (Saida and Schiff, 1989). In fact, prior metabolism of <sup>35</sup>SO<sub>4</sub><sup>2-</sup> in the mitochondria is necessary to produce intermediates

which lead to subsequent labeling of the sulfolipid in the chloroplasts. Addition of non-radioactive compounds during joint incubations of chloroplasts and mitochondria, or during incubations of chloroplasts with the medium from a previous mitochondrial incubation indicate that sulfite is the most effective compound diluting the label incorporated into sulfolipid; cysteine is less effective. Incubation of chloroplasts alone with  $^{35}\text{S}$ -labelled sulfite or cysteine confirms that sulfite is incorporated very efficiently into chloroplast sulfolipid; cysteine is somewhat less effective. Labeled sulfite and cysteine are both found in the medium surrounding mitochondria incubated with  $^{35}\text{SO}_4^{2-}$  and are therefore formed by the sulfate metabolizing center on the outside of the mitochondrial inner membrane. Sulfolipid labeling from  $^{35}\text{SO}_4^{2-}$  is inhibited by S-sulfocysteine or cysteine sulfinic acid, probably because these compounds can contribute non-radioactive sulfite to dilute the radioactive pool; they also inhibit labeling of cysteine from  $^{35}\text{SO}_4^{2-}$ . Based on this work, the pathway(s) of formation of the sulfonic acid group of the chloroplast sulfolipid in *Euglena* seems to be the conversion of sulfate via APS to sulfite (or cysteine) in the mitochondria, followed by conversion of sulfite (or cysteine) to the sulfolipid sulfonic acid group in the chloroplast (Saida and Schiff, 1989).

We have also been engaged in purifying the enzymes of sulfate metabolism from *Euglena* mitochondria. We have purified the mitochondrial ATP sulfurylase to homogeneity and investigation of the properties are under way (Li and Schiff, in preparation). We are particularly interested in the mechanism of inhibition by inorganic phosphate (Saida *et al.*, 1989a,b) which may of regulatory significance. The APS sulfotransferase has also been highly purified and a number of properties have been studied (Li and Schiff, 1989) but lack of space precludes a more detailed discussion here.

When *Euglena* mitochondria are incubated with  $^{35}\text{SO}_4^{2-}$  and a source of ATP, a previously unidentified labeled compound appears in the surrounding medium. We have identified this compound as tyrosine-O-sulfate by coelectrophoresis with synthetic material at pH 2.0, 5.8 or 8.0, hydrolysis to sulfate and tyrosine with mild acid or aryl sulfatase from *Aerobacter*, and by incorporation of  $^{14}\text{C}$ -tyrosine under the same conditions used for  $^{35}\text{SO}_4^{2-}$  (Saida *et al.*, 1989a,b). The *Aerobacter* enzyme does not catalyze the hydrolysis of tyrosine methyl ester to tyrosine; thus the compound formed is tyrosine-O-sulfate, not the sulfated methyl ester. There are a number of reports in the literature of sulfation of tyrosine methyl ester under conditions where free tyrosine is not a substrate for sulfation. The metabolic origin of free tyrosine-O-sulfate is still somewhat of a mystery, although in some organisms, at least some can arise from tyrosine-O-sulfate of protein. However, we have found that *Euglena* does not sulfate the tyrosine of protein ruling this out as a source of the free compound. Chloroplasts do not form tyrosine-O-sulfate from sulfate and ATP but both chloroplasts and mitochondria form this compound from  $\text{PAP}^{35}\text{S}$ ; this is consistent with the fact that chloroplasts lack the sulfate activating enzymes. No tyrosine need be added indicating that the tyrosine is supplied from endogenous sources. The system forming tyrosine-O-sulfate is membrane-bound and may be involved in tyrosine transport, in addition to the usually-ascribed role of phenol detoxification (Saida *et al.*, 1989a,b).

It will be apparent from the material presented that in *Euglena* the mitochondria are very active in sulfate metabolism and that this activity is necessary to generate

PAPS, sulfite and cysteine which are exported to other cellular compartments. Unlike higher plants, *Euglena* cells do not seem to rely on the chloroplasts for much beyond photosynthetic carbon dioxide reduction to carbohydrate. This may be the primary reason why (so far) *Euglena* is the only organism from which the plastids can be completely eliminated if a reduced carbon source is made available to the cells (Osafune and Schiff, 1983).

## References

- Brunold, C. and Schiff, J.A. 1976. Studies on sulfate utilization by algae. 15. Enzymes of assimilatory sulfate reduction in *Euglena* and their cellular localization. *Plant Physiol.* 57: 430-436.
- Li, J. and Schiff, J.A. 1989. Purified APS sulfotransferase from *Euglena* mitochondria. *Plant Physiol.* 89: S-50.
- Noller, C.R. 1952. Chemistry of organic compounds. W.B. Saunders, Philadelphia and London, p 271.
- Osafune, T., Stern, I. and Schiff, J.A. 1983. W<sub>10</sub>BSmL, a mutant of *Euglena gracilis* var. *bacillaris* lacking plastids. *Exper. Cell Research* 148: 530-535.
- Saidha, T., Stern, A.I. and Schiff, J.A. 1985. Localization of a sulphate-activating system within *Euglena* mitochondria. *Biochem. J.* 232: 357-365.
- Saidha, T., Na, S.-Q. Na, Li, J. and Schiff, J.A. 1988. A sulphate-activating system within *Euglena* mitochondria. *Biochem. J.* 253: 533-539.
- Saidha, T., Hanfstingl, U. and Schiff, J.A. 1989a. *Euglena* mitochondria and chloroplasts form tyrosine-O-sulfate. *Plant Physiol.* 89: S-76.
- Saidha, T., Hanfstingl, U. and Schiff, J.A. 1989b. Formation of tyrosine-O-sulfate by mitochondria and chloroplasts of *Euglena*. *Arch. Biochem. Biophys.* 272: 237-244.
- Schiff, J. A. 1983. Reduction and other metabolic reactions of sulfate. In: *Encyclopedia of plant physiology*, New series 15A, Inorganic plant nutrition, Läuchli, A. and Bielecki, R.L. eds. pp. 402-421, Springer, Berlin.

## **Section 1.**

### **Regulatory aspects of uptake and reduction of sulfate and incorporation into amino acids**

## **Contents**

1.1	W.J. Cram, Uptake and transport of sulfate	3
1.2	C. Brunold, Reduction of sulfate to sulfide	13
1.3	J. Giovanelli, Regulatory aspects of cysteine and methionine synthesis	33
1.4	Discussion	49

# UPTAKE AND TRANSPORT OF SULFATE

W.J. Cram

*Department of Biology, Ridley Building, University of Newcastle upon Tyne, NE1 7RQ, U.K.*

## Contents

The natural history of sulfur in plants	3
The mechanism of sulfate transport across the plasmalemma	4
– Evidence for a proton co-transport system and for recycling	4
The fate of sulfate after crossing the plasmalemma	5
Transport function	7
– Intracellular coordination	7
– Coordination in the whole plant	8
Literature cited	10

## The natural history of sulfur in plants

'It is hard to imagine a civilization without onions'(1). The greatest culinary impact of plant metabolism must be the subtle changes which sulfur undergoes. It is odd, therefore, to find that this field of biochemistry is relatively neglected.

Amongst the substances that flow into a plant sulfur comes fifth or sixth in quantity. With C content as 100 (and H and O greater because of high water content), N is 10 and S is around 0.6 (as are P, K and Ca) in the majority of plant species examined (27, 28). The S/N ratio of 1/20 in many species (*e.g.* 16) reflects their proportion in proteins. Only in those taxa where excess S is accumulated as aromatic isothiocyanates (*Brassicaceae*) or S-alkylcysteine sulfoxides (*Liliaceae*), or as sulfate (*Welwitschia*, *Desmarestia*, *Gossypium*, *Lepidium*, etc) is the ratio of S to N significantly higher (19). These contents arise by uptake over the life of the plant, so that at any stage one would expect to find that the relative uptake rates of S and N are also in the ratio 1/20. The mechanism(s) matching uptake and reduction of  $\text{SO}_4^{2-}$  and  $\text{NO}_3^-$  in these proportions is a matter to be considered below.

Sulfur is generally taken up as sulfate. In contrast to N and P, which are frequently available at low to vanishingly low concentrations, S is often available at relatively high concentrations – 25 mM in sea water, 0.1 to 1 mM in fresh water, and of the order of 0.5 mM in arable lands (19, 28, 41). This leads to the thought that in the evolution of plants there may have been less selection pressure for efficient use of S than for N and P. This idea does not agree with the finding that the scavenging ability of plants for S seems to be about as effective as that for N and P, as evidenced by the similar 'affinity' of their transport systems for  $\text{SO}_4^{2-}$ ,  $\text{NO}_3^-$  and  $\text{HPO}_4^{2-}$  (*e.g.* 25, 28). Nevertheless, the apparent inefficiency of internal utilisation of S by plants might have an evolutionary origin.

*Sulfur Nutrition and Sulfur Assimilation in Higher Plants*

*edited by H. Rennenberg et al., pp. 3–11*

©1990 SPB Academic Publishing bv, The Hague, The Netherlands

Sulfate uptake from the soil is supplemented by  $\text{SO}_2$  uptake from the air, particularly since the advent of *Homo sapiens*. In many countries crop plants have relied for their sulfur supply on atmospheric S as well as incidental S in fertilisers. As these sources are purified, it seems likely that S will increasingly limit productivity (e.g. 41). It may then become economically more important to understand the S economy of plants.

Following uptake of  $\text{SO}_4^{2-}$  by roots, its reductive assimilation is considered to occur almost exclusively in leaves (e.g. 19), though data on the assimilatory capacity of roots is very scanty. Most of the sulfate arriving in leaves is reduced and reduced-S is retranslocated to various sinks, though a fraction (10-20%) is often accumulated as  $\text{SO}_4^{2-}$ .

At higher external concentrations a larger fraction of the S arriving in shoots is held (not 'stored' - see below) as  $\text{SO}_4^{2-}$  (41). Sulfate toxicity is probably related to its effect in 'salting out' proteins and nucleic acids (e.g. 18, 43).

At lower external concentrations, and most dramatically after external sulfate removal, S is not redistributed as would be expected from a comparison with N, P and K. The latter elements all move out of mature tissues to succour the young growing shoots, leaving mature leaves to show the first deficiency symptoms. By contrast, although sulfate-S is readily mobilised from roots and stems, it is not mobilised but is rather retained in old leaves. These leaves then remain green while young shoots become chlorotic - the typical symptom of S deficiency (2, 5). One of the most puzzling aspects of sulfur physiology is the apparent immobility of S in mature leaves.

## The mechanism of sulfate transport across the plasmalemma

### *Evidence for a proton co-transport system and for recycling*

The evidence necessary to establish the operation of a proton co-transport system unequivocally is that the free energy available from proton inflow is greater than that needed for  $\text{SO}_4^{2-}$  inflow with the  $\text{H}^+/\text{SO}_4^{2-}$  stoichiometry observed: that  $\text{H}^+$  and  $\text{SO}_4^{2-}$  fluxes change in parallel in response to changes in the external concentrations of  $\text{H}^+$  and  $\text{SO}_4^{2-}$ : and that the electrical current across the membrane accounts for any inequality between  $\text{H}^+$  and  $\text{SO}_4^{2-}$  flows. Complete characterisation also demands knowledge of the response of the flows to internal  $\text{H}^+$  and  $\text{SO}_4^{2-}$  concentrations and to the electrical potential difference across the plasmalemma.

Measurements of all these variables have not been made on any single system, but more work has been done on microorganisms than on higher plants.

In *Penicillium notatum* (11)  $\text{SO}_4^{2-}$  and  $\text{H}^+$  influxes showed a 1/1,  $\text{H}^+/\text{SO}_4^{2-}$  stoichiometry in response to changes in external  $\text{H}^+$ ,  $\text{SO}_4^{2-}$  and  $\text{Ca}^{2+}$  concentrations, and the kinetics were consistent with initial binding of either  $\text{H}^+$  or  $\text{Ca}^{2+}$  followed by  $\text{SO}_4^{2-}$ . It was suggested that one  $\text{Ca}^{2+}$  ion entered with each  $\text{H}^+$  and  $\text{SO}_4^{2-}$  ion. Because in longer term experiments only 0.25  $\text{Ca}^{2+}$  entered per  $\text{SO}_4^{2-}$ , it was suggested that 3/4 of the  $\text{Ca}^{2+}$  entering recycled in the pump with another anion. This is an intriguing proposal, but caution is suggested by the non-specificity of the cation effects, particularly the small difference between  $\text{Ca}^{2+}$  and  $\text{Mg}^{2+}$ . On the other hand, one  $\text{H}^+$  may not always provide sufficient energy to drive in one  $\text{SO}_4^{2-}$ ,

and an additional driving force could be provided by another cation flowing in with  $\text{SO}_4^{2-}$ .

In *Saccharomyces cerevisiae* (33) stoichiometries have been well established though less extensive kinetics have been obtained than for *P. notatum*. The ratio of  $\text{H}^+$  to  $\text{SO}_4^{2-}$  influx in *S. cerevisiae* was  $3.4 \pm 0.5$ , and with each  $\text{SO}_4^{2-}$  entering  $1.04 \pm 0.14$   $\text{K}^+$  flowed out.  $\text{Ca}^{2+}$  influx was zero. Three  $\text{H}^+$  were postulated to drive one  $\text{SO}_4^{2-}$  in, with one  $\text{K}^+$  flowing out and balancing the charge transfer. A non-specific stimulation of influx by external cations was again observed. It was suggested that they might reduce electrical double layers, thus providing greater access for  $\text{SO}_4^{2-}$  to the pump. The stoichiometries in *Saccharomyces* are convincing, and a 3/1,  $\text{H}^+/\text{SO}_4^{2-}$  is an economical hypothesis. However, the stoichiometry of  $\text{H}^+$  to  $\text{SO}_4^{2-}$  in *Penicillium* is equally convincing, and generalisations about the driving cation would be premature.

In the marine habitat, where the external pH is about 8.2, the free energy change available from  $\text{H}^+$  influx is substantially less, and it is not surprising to find that  $\text{SO}_4^{2-}$  influx is stimulated by  $\text{K}^+$  rather than  $\text{H}^+$  in some algae (28).

In higher plants only *Lemna* has been studied in any detail (25). The authors calculated that two  $\text{H}^+$  per  $\text{SO}_4^{2-}$  would provide sufficient driving force for  $\text{SO}_4^{2-}$  uptake, but favoured a stoichiometry of 3  $\text{H}^+$  per  $\text{SO}_4^{2-}$  to account for the electrical current apparently carried by the pump. This current was observed as depolarisations of the membrane more or less proportional to the postulated activity of the  $\text{SO}_4^{2-}$  pump. (If the membrane conductance remains constant, then changes in p.d. will be proportional to changes in electrical current.) The  $\text{SO}_4^{2-}$  influx responded to changes in external pH and to fusicoccin in a manner consistent with a three proton symport, but direct measurement of the stoichiometry has yet to be made.

The main features of the kinetics of proton-linked co-transport systems have been worked out in detail and investigated in a number of systems, notably for  $\text{Cl}^-$  influx in *Chara corallina* (35) and glucose in *Chlorella vulgaris* (discussed in 34). In addition to a coupled influx one may observe counter-intuitive kinetics, recycling in the pump, or slip, and transinhibition of influx by the transported ion or molecule. These characteristics appear to tie together some scattered observations in the literature.

Studies of influx isotherms alone (e.g. 26; discussion in 38) do not provide information of the type necessary to establish the operation of a proton/sulfate cotransport system, though they have been used as a basis for an alternative model (26), for which the theoretical basis is unclear, in particular because of the theoretical findings of Sanders (34). These theoretical studies show that the kinetics of a relatively simple cotransport system would be expected to deviate from a rectangular hyperbola (34). Consequently, such deviations may be able to establish kinetic characteristics of a hypothetical single transport system, but it is difficult to see how they can be interpreted as positive evidence of the operation of several independent pumps.

Sulfate influx across the plasmalemma is up a large free energy gradient (7, 42). It is therefore surprising to observe that  $\text{SO}_4^{2-}$  appears to leak out again rapidly, which would dissipate much of the energy put into influx pumping. This has been observed both in *Lemna* (12, 42; see discussion of data from ref. 12 in ref. 9), and also in carrot and pea roots (7, 15). However, the efflux of tracer could occur by a mechanism other than energetically wasteful leakage. Recycling within the pump, which would only be observed when using tracers, would be one such non-dissipative mechanism. Observations consistent with a recycling mechanism are, first, that when



the external  $\text{SO}_4^{2-}$  concentration is raised influx and efflux rise in parallel (7) and, second, that efflux rises virtually instantaneously after the external  $\text{SO}_4^{2-}$  concentration is raised (Bell *et al.*, this volume). Both observations are most easily explained as tracer recycling in the pump, rather than an energy-dissipating leak. In this type of mechanism, the amount of 'slippage' would be expected to vary with conditions (cf. 15).

Trans-inhibition as a type of negative feedback will be discussed below.

### The fate of sulfate after crossing the plasmalemma

In prokaryotic cells, sulfate has one fate – 'local' metabolism – and sulfate uptake must be geared to match this, with the fine control on uptake preventing the cell wasting energy or flooding the cytoplasm with toxic  $\text{SO}_4^{2-}$  or unwanted osmoticum.

In higher plants additional cellular and intercellular transport systems operate. To put these into perspective the following picture is offered. Uptake, reduction and retranslocation may be seen in the same terms of matching supply to demand throughout the plant while minimising local perturbations. But what of the vacuole? Is the vacuole part of the normal flow path for metabolised sulfur? To assess this possibility, growth rates and turnover times of  $\text{SO}_4^{2-}$  can be compared. In *Lemna*, with relative growth rates of 3 to  $14 \times 10^{-3} \text{ h}^{-1}$ , rate constants for vacuolar turnover varied in parallel with growth rate from 4 to  $14 \times 10^{-3} \text{ h}^{-1}$  (13, 14, 42). Similarly, in terrestrial plants where a relative growth rate of  $0.25 \text{ d}^{-1}$ , or  $10^{-2} \text{ h}^{-1}$ , would be possible, vacuolar  $\text{SO}_4^{2-}$  turns over with a rate constant of  $10^{-3} \text{ h}^{-1}$  (Bell *et al.*, this volume; and calculated from 2). These figures strongly suggest that vacuoles turn over too slowly to be regarded as on the main path of sulfate metabolism. Vacuolar accumulation must play some longer term role, as will be discussed in a later section.

To carry these investigations forward, one must measure fluxes and compartment contents into and within the cell. Of the various methods that have been used, only compartmental analysis of  $^{35}\text{S}$  tracer kinetics has provided any systematic values. The necessary conditions, precautions and limitations of the method have been discussed many times, most recently in (9). The basic conditions are that the tissue must be at a steady state; the data must be impeccable; curve fitting must be objective; and the time scale must be adequately broad. In addition, one should validate the accuracy of the curve fitted and provide proof of the assumed underlying compartmental structure.

Extending the compartmental analysis to include chemical as well as physical compartments (or pools), and extending it also to the quasi-steady state, have provided valuable additional results in studying cellular sulfur physiology.

Some values of fluxes across plasmalemma and tonoplast and cytoplasmic and vacuolar contents have been obtained (7, 8, 42; Bell *et al.*, this volume). In ref. 37 the tissue appears not to have been at a steady state and the values obtained consequently uncertain). The results for the plasmalemma were discussed in the previous section. If  $\text{SO}_4^{2-}$  is metabolised,  $^{35}\text{S}$  tracer kinetics measured solely by exchange with the external solution will be insufficient to calculate fluxes and physical and chemical compartment contents, since more than two physical compartments are present. However, the additional information required to make the more extensive calculations needed to describe the more complex system can be obtained by direct

measurement of the quantity of tracer in metabolic pools following chemical isolation of the metabolites, lengthy and tedious as obtaining these values may be. This has been done most successfully by Giovanelli *et al.* (21, 22). Such a combination of tracer exchange kinetics and metabolic pool kinetics must be the approach used in future investigations of sulfur transport in cells.

The kinetics are simpler in the particular case where  $\text{SO}_4^{2-}$  flow into metabolites is irreversible (7, 8, 42). In such cases the plasmalemma fluxes can be validly calculated from exchange data alone, but tonoplast fluxes cannot be calculated.

Because organelles have such a high surface to volume ratio, it is probable that they will be kinetically indistinguishable from the bulk cytoplasm. Analysing isolated organelles therefore seems likely to be the only available approach to understanding their transport characteristics. Valuable results have been so obtained (*e.g.* 36, review in 38), but their extrapolation to the intact cell remains an uncertainty.

## Transport function

### *Intracellular coordination*

Although the function of transport systems cannot be the same in cells of roots, leaves and aquatic organisms, they will have certain features in common, which will be considered in this section. Differences will be considered in the next section.

Induction of sulfate uptake by S starvation is found in microorganisms (*e.g.* 17, 28). In addition, or as the cause of the phenomenon, intracellular negative feedback to the sulfate porter is found. Attempts have been made to determine whether the concentration of internal  $\text{SO}_4^{2-}$  or of internal reduced S constitutes the signal. By using the  $\text{SO}_4^{2-}$  analogues  $\text{SeO}_4^{2-}$  and  $\text{MoO}_4^{2-}$ , which are transported but do not produce stable reduction products (10), it has been demonstrated that internal feedback from  $\text{SO}_4^{2-}$ , as distinct from reduced S, must occur. The kinetics indicated that the mechanism of this effect was trans-inhibition of the proton cotransport system. A further finding in the same paper was that internal cysteine *also* fed back to the  $\text{SO}_4^{2-}$  influx pump.

In many other papers the 'either – or' question ('does  $\text{SO}_4^{2-}$  or reduced-S feed back?') has been asked. The lack of a clear answer suggests that the 'both...and' alternative may be correct, *viz* both  $\text{SO}_4^{2-}$  and reduced-S may feed back to control sulfate influx. However, in nearly every case the results are ambiguous because of the difficulty of measuring cytoplasmic concentrations. This is particularly true in higher plants where the 'either-or' question has been asked by many authors over the last few decades (see 38 for a recent review). The answer, additionally, must be more complex in higher plants than in microorganisms because of the large vacuoles in the former.

The added complexity is illustrated by results from work on excised carrot root tissue in which vacuolar sulfate was found to feed back to the tonoplast influx but not to the plasmalemma influx, and cysteine and methionine, when fed to the tissue, appeared to have no effect on any  $\text{SO}_4^{2-}$  fluxes. The suggestion was made that vacuolar sulfate has its own accumulation control system, that sulfate assimilatory biochemistry has its own feedback regulation, and that the plasmalemma influx is not

controlled by either of these (8). A parallelism was drawn with end product inhibition in a branched biochemical pathway, where the end product of a particular branch feeds back to a step after the branch point. This hypothesis can only be tested by measuring separately the plasmalemma and tonoplast fluxes and the internal concentrations of putative feedback effectors, and looking for a causative relationship between them. In the absence of such rigorous but lengthy measurements the situation will almost certainly remain unclear.

There is independent evidence for a degree of homeostasis of  $\text{SO}_4^{2-}$  accumulation in the vacuole, for instance in *Lemna* (13), as also in chloroplasts (36). Whether this implies homeostasis of  $\text{SO}_4^{2-}$  concentration in leaf cytoplasm, in contrast to the large variation found in carrot root cell cytoplasm, remains to be seen.

The discovery of a 'hypercontrolled' variant in carrot tissue culture (20) provides a powerful alternative approach to the problem of control of sulfate transport. The greater external sulfate-induced  $\text{SO}_4^{2-}$  efflux, and the greater inhibition of  $\text{SO}_4^{2-}$  influx by cystine fed to the tissue, led the authors to suggest that this variant combined greater recycling with greater sensitivity to internal reduced S than in the wild type. However, the uptake was measured over 2 hours and thus would almost certainly have included both metabolic and vacuolar accumulation. Further critical measurements of fluxes across individual membranes are needed to support the suggested interpretation.

Most recently, Rennenberg and co-workers have discovered that glutathione is a potent inhibitor of sulfate uptake in tobacco tissue culture (30). This was only found in heterotrophic cells, and took some hours to develop. The latter observation suggests that there is no direct feedback from glutathione to the sulfate porter, since this would be rapid. Its place in the integration of S transport in the intact plant will be referred to below.

Sulfate 'influx' to several cells also responds to light (*e.g.* 24, 25); internal  $\text{Cl}^-$  concentration (6), turgor (*e.g.* 23) and external calcium concentration (see *e.g.* 38). The interpretation of these effects depends on further analysis of the individual membrane events involved.

The final regulatory feature of  $\text{SO}_4^{2-}$  transport to be discussed is the possibility that a linkage of  $\text{SO}_4^{2-}$  to  $\text{NO}_3^-$  influx contributes to the N/S ratio typical of plants. The finding of a coupling between  $\text{NO}_3^-$  and  $\text{SO}_4^{2-}$  reduction (32) is extremely stimulating, given this background. However,  $\text{NO}_3^-$  and  $\text{SO}_4^{2-}$  reduction predominantly take place in the leaf, while N/S ratios in the whole plant are determined by the ratio taken up by the root. Unless a regulatory linkage extends to root uptake, the linkage during assimilation can only serve as fine tuning at the biochemical level (which may nonetheless be important). The necessity for uptake linkage is also brought into question if feedback from reduced S to  $\text{SO}_4^{2-}$  influx and reduced N to  $\text{NO}_3^-$  influx is confirmed: such feedback would by itself match relative uptake rates to relative utilisation rates.

### *Coordination in the whole plant*

There are two overriding considerations when the whole plant is viewed. The first is that every cell is within a few cells' distance of specialised long distance transport sys-

tems bringing S to it and taking S from it. This is in sharp contrast to *Lemna*, for instance, in which each cell has more or less direct contact with a virtually constant source and sink.

The second consideration is that once inside the plant the S content is fixed, so that matching supply to growth rate, or S to N uptake in the required proportion, must take place at the root.

As in microorganisms, the terrestrial plant shows regulation of  $\text{SO}_4^{2-}$  uptake (2, 4, 5, 38). In the case of the tropical legume *Macroptilium atropurpureum*, for instance (4), after external S is removed from the growing plant, growth begins to fall two days later and deficiency symptoms set in. Before this stage potential  $\text{SO}_4^{2-}$  uptake by roots (*i.e.* uptake measured immediately after external  $\text{SO}_4^{2-}$  is resupplied) has begun to increase and it reaches a maximum after 4 days. After return to nutrient medium with adequate S,  $\text{SO}_4^{2-}$  uptake falls more rapidly to its original value, completing the adjustment in about 10 hours. The speed of transport induction is comparable to that in *Lemna* (25), which suggests that it is related to the speed of biochemical adjustment of the pump rather than to rates of signalling from one part of the plant to another. The speed of down-regulation after re-supplying external  $\text{SO}_4^{2-}$  is comparable to the speed of down-regulation after ringing sunflower plants (3). The uptake of  $\text{NO}_3^-$  begins to fall within one hour of ringing the stem (3), so the slower response of  $\text{SO}_4^{2-}$  uptake must be related to events in the root, not to the speed of delivery of a signal carried by mass flow in the phloem. It is obviously critical to the plant to prevent toxic build up of sulfate, but this consideration only hints at a reason for breakdown of porters being ten times faster than their synthesis (if indeed this is the origin of the change in transport rates), and does not at all explain why  $\text{SO}_4^{2-}$  uptake falls so much slower than  $\text{NO}_3^-$  uptake after ringing.

The apparent matching of supply to demand is accompanied by an apparent linkage of  $\text{SO}_4^{2-}$  to  $\text{NO}_3^-$  uptake (5). These first indications of a link are suggestive, but do not at this stage show the 20 to 1 ratio to which some physiological significance could be ascribed.

Whether transport regulation in the root occurs at the plasmalemma or at the xylem loading sites is yet to be determined. It is perhaps not surprising, but nevertheless a salutary warning, to find that uptake rates by excised roots are substantially less than those of intact roots (39).

Once within the plant, sulfate moves to leaves where it is reduced, though some direction of the sulfate to younger leaves, presumably after transfer to the phloem, is indicated by the results of Smith and Lang (40). Rennenberg and co workers (see 31) have demonstrated that  $\text{SO}_4^{2-}$ , as well as S amino acids and glutathione, can be transported in the phloem.

The control of  $\text{SO}_4^{2-}$  accumulation and redistribution poses problems which are currently under investigation (see Bell *et al.*, this volume). Major flows of reduced S must occur from shoot to root. The puzzling feature is that after S deprivation,  $\text{SO}_4^{2-}$  previously stored in root and stem is mobilised within a few days (2, 4) with a  $\text{SO}_4^{2-}$  turnover constant of the order of  $10^{-2} \text{ h}^{-1}$ , whereas there may even be an increase in  $\text{SO}_4^{2-}$  content of mature leaves at the same time that young leaves are becoming deficient (4). Since phloem can readily load  $\text{SO}_4^{2-}$  directly (31) the probability is that vacuoles of leaves have different export characteristics from those of roots. Direct measurements confirm that this is indeed the case (Bell *et al.*, this volume).

The transport of S compounds into and out of phloem, with glutathione playing a central role (29), has not yet been investigated. Phloem loading and unloading of S compounds is likely to repay study particularly in relation to seed filling.

Finally, whether the plant can dispose of significant excess S as  $H_2S$  (see 29) is also a matter for further quantitative investigation.

### Literature cited

1. Beck, S., Bertholle, L. and Child, J. 1966. *Mastering the art of french cooking*. Harmondsworth: Penguin.
2. Bouman, D. 1975. The uptake and transport of sulphur in plants. In: *Sulphur in australasian agriculture*, McLachlan, K.D. ed. pp.79-86. Sydney: Sydney U.P.
3. Bowling, D.J. 1981. Evidence for an ion uptake controller in *Helianthus annuus*. In: *Structure and function of plant roots*, Brouwer, R. *et al.* eds. pp.179-183. The Hague: Nijhoff/Junk.
4. Clarkson, D.T., Smith, F.W. and Vanden Berg, P.J. 1983. Regulation of sulphate transport in a tropical legume, *Macroptilium atropurpureum* cv. Siratro. *J. Exp. Bot.* 34: 1463-1483.
5. Clarkson, D.T., Saker, L.R., Purves, J.V. and Lee, R.B. 1989. Depression of nitrate and ammonium transport in barley plants with diminished sulphate status. Evidence of co-regulation of nitrogen and sulphate intake. in press.
6. Cram, W.J. 1980. A common feature of the uptake of solutes by root parenchyma cells. *Aust. J. Plant Physiol.* 7: 41-49.
7. Cram, W.J. 1983a. Characteristics of sulfate transport across plasmalemma and tonoplast of carrot root cells. *Plant Physiol.* 72: 204-211.
8. Cram, W.J. 1983b. Sulphate accumulation is regulated at the tonoplast. *Plant Sci. Lett.* 31: 329-338.
9. Cram, W.J. 1988. Transport of nutrient ions across cell membranes *in vivo*. In: *Advances in plant nutrition*, Vol. 3, Tinker, B. and Lauechli, A. eds. pp. 1-53.
10. Cuppoletti, J. and Segel, I.H. 1974. Transinhibition kinetics the sulfate transport system of *Penicillium notatum*: analysis based on an iso uni uni velocity equation. *J. Memb. Biol.* 17: 239-252.
11. Cuppoletti, J. and Segel, I.H. 1975. Kinetics of sulfate transport by *Penicillium notatum*. Interactions of sulfate, protons and calcium. *Biochemistry* 14: 4712-4718.
12. Datko, A.H. and Mudd, S.H. 1984a. Sulfate uptake and its regulation in *Lemna paucicostata* Hegelm. 6746. *Plant Physiol.* 75: 466-473.
13. Datko, A.H. and Mudd, S.H. 1984b. Responses of sulfur-containing compounds in *Lemna paucicostata* Hegelm. 6746 to changes in availability of sulfur sources. *Plant Physiol.* 75: 474-479.
14. Datko, A.H., Mudd, S.H., Giovanelli, J. and Macnicol, P.K. 1978. Sulfur-containing compounds in *Lemna perpusilla* 6746 grown at a range of sulfate concentrations. *Plant Physiol.* 62: 629-635.
15. Deane-Drummond, C.E. 1987. The regulation of sulphate uptake following growth of *Pisum sativum* L. seedlings in S nutrient limiting conditions. Interaction between nitrate and sulphate transport. *Plant Sci.* 50: 27-35.
16. Dijkshoorn, W. and van Wijk, A.L. 1967. The sulphur requirements of plants as evidenced by the sulphur-nitrogen ratio in the organic matter. A review of published data. *Plant and Soil* 26: 129-157.
17. Eddy, A.A. 1982. Mechanisms of solute transport in selected eukaryotic microorganisms. *Adv. Microbial Physiol.* 23: 1-78.
18. Edelhoch, H. and Osborne, J.C.Jr. 1976. The thermodynamic basis of stability of proteins, nucleic acids, and membranes. *Adv. Protein Chem.* 30: 183-250.
19. Evans, L.T. 1975. Sulphur in agriculture. In: *Sulphur in australasian agriculture*, McLachlan, K.D. ed. pp. 3-9. Sydney: Sydney U.P.
20. Furner, I.J. and Sung, Z.R. 1982. Regulation of sulfate uptake in carrot cells: properties of a hyper-controlled variant. *Proc. Natl. Acad. Sci., U.S.A.* 79: 1149-1153.
21. Giovanelli, J., Mudd, S.H. and Datko, A.H. 1978. Homocysteine biosynthesis in green plants. Physiological importance of the transsulfurylation pathway in *Chlorella sorokiniana* growing under steady state conditions with limiting sulfate. *J. Biol. Chem.* 253: 5665-5677.
22. Giovanelli, J., Mudd, S.H. and Datko, A.H. 1985. Quantitative analysis of pathways of methionine metabolism and their regulation in *Lemna*. *Plant Physiol.* 78: 555-560.

23. Ingelsten, B. 1966. Absorption and transport of sulfate by wheat at varying mannitol concentration in the medium. *Physiol. Plant.* 19: 563-57.
24. Jeschke, W.D. and Simonis, W. 1965. Über die Aufnahme von Phosphat- und Sulphationen durch die Blätter von *Elodea densa* und ihre Beeinflussung durch Licht, Temperatur und Außenkonzentration. *Planta* 67: 6-32.
25. Lass, B. and Ullrich-Eberius, C.I. 1984. Evidence for proton/ sulfate cotransport and its kinetics in *Lemna gibba* G1. *Planta* 161: 53-60.
26. Nissen, P. 1974. Uptake mechanisms: inorganic and organic. *Annu. Rev. Plant Physiol.* 25: 53-79.
27. Pitman, M.G. and Cram, W.J. 1977. Regulation of ion content in whole plants. *Symp. Soc. Exp. Biol.* 31: 391-424.
28. Raven, J.A. 1980. Nutrient transport in microalgae. *Adv. Microbial Physiol.* 21: 47-226.
29. Rennenberg, H. 1984. The fate of excess sulfur in higher plants. *Annu. Rev. Plant Physiol.* 35: 121-153.
30. Rennenberg, H., Polle, A., Martini, N. and Thoene, B. 1989. Interaction of sulfate and glutathione (GSH) transport in cultured tobacco cells. *Planta* 176: 68-74.
31. Rennenberg, H., Schmitz, K. and Bergmann, L. 1979. Long distance transport of sulfur in *Nicotiana tabacum*. *Planta* 147: 57-62.
32. Reuveny, Z., Dougall, D.K. and Trinity, P.M. 1980. Regulatory coupling of nitrate and sulfate assimilation pathways in cultured tobacco cells. *Proc. Natl. Acad. Sci. U.S.A.* 77: 6670-6672.
33. Roomans, G.M., Kuypers, G.A.J., Theuvenet, A.P.R. and Borst-Pauwels, G.W.F.H. 1979. Kinetics of sulfate uptake by yeast. *Biochim. Biophys. Acta* 551: 197-206.
34. Sanders, D. 1986. Generalised kinetic analysis of ion-driven cotransport systems: II. Random ligand binding as a simple explanation for non-Michaelian kinetics. *J. Memb. Biol.* 90: 67-87.
35. Sanders, D. and Hansen, U.-P. 1981. Mechanism of  $\text{Cl}^-$  transport at the plasma membrane of *Chara corallina*: II. Transinhibition and the determination of  $\text{H}^+/\text{Cl}^-$  binding order from a reaction kinetic model. *J. Memb. Biol.* 58: 139-153.
36. Schroepel-Meier, G. and Kaiser, W.M. 1988. Ion homeostasis in chloroplasts under salinity and mineral deficiency. II. Solute distribution between chloroplasts and extra-chloroplastic space under excess or deficiency of sulfate, phosphate, or magnesium. *Plant Physiol.* 87: 828-832.
37. Smith, I.K. 1981. Compartmentation of sulfur metabolites in tobacco cells. Use of efflux analysis. *Plant Physiol.* 68: 937-940.
38. Smith, I.K. 1989. Sulfate and amino acid transport. In: Sulfur biochemistry in plants, Smith, I.K., Thompson, J.F. and Madison, J.D. eds., *Am.Soc. Plant Physiol., Monograph*. New York: Academic, in preparation.
39. Smith, I.K. and Cheema, H.K. 1985. Sulphate transport into plants and excised roots of soybean (*Glycine max* L.). *Ann. Bot.* 56: 219-224.
40. Smith, I.K. and Lang, A.L. 1988. Translocation of sulfate in soybean (*Glycine max* L. Merr). *Plant Physiol.* 86: 798-802.
41. Syers, J.K., Skinner, R.J. and Curtin, D. 1987. Soil and fertiliser sulphur in U.K. agriculture. The Fertiliser Society, Procs. No.264. pp 1-43.
42. Thoirion, A., Thoirion, B., Demarty, M. and Thellier, M. 1981. Compartmental analysis of sulphate transport in *Lemna minor* L., taking plant growth and sulphate metabolization into consideration. *Biochim. Biophys. Acta* 644: 24-35.
43. von Hippel, P.H., Peticolas, V., Schack, L. and Karlson, L. 1973. Model studies on the effects of neutral salts on the conformational stability of biological macromolecules. I. Ion binding to polyacrylamide and polystyrene columns. *Biochemistry* 12: 1256-1264.

# REDUCTION OF SULFATE TO SULFIDE

C. Brunold

*Pflanzenphysiologisches Institut der Universität Bern, Altenbergrain 21, 3013  
Bern, Switzerland*

## Contents

Introduction	14
Activation of sulfate by ATP sulfurylase	14
Measurement of ATP sulfurylase	14
– Distribution of ATP sulfurylase	16
– Properties	16
Formation of adenosine 3'-phosphate 5'-phosphosulfate (PAPS) by adenosine 5'-phosphosulfate (APS) kinase	16
– Measurement of APS kinase	16
– Distribution of APS kinase	16
– Properties	17
Sulfotransferase reactions	17
– APS sulfotransferase	17
– Measurement	17
– Distribution	17
– Properties	18
– PAPS sulfotransferase	18
– Measurement	18
– Distribution	18
– Properties	19
Reduction	19
Sulfite reductase	19
– Measurement	19
– Distribution	19
– Properties	19
– Organic thiosulfate reductase	19
– Measurement	19
– Distribution and Properties	20
Localization	20
Regulation	22
Concluding remarks	25
Acknowledgements	25
Literature cited	26

*Sulfur Nutrition and Sulfur Assimilation in Higher Plants*

*edited by H. Rennenberg et al., pp. 13–31*

©1990 SPB Academic Publishing bv, The Hague, The Netherlands

## Introduction

Higher plants and many microorganisms growing with sulfate as a sulfur source reduce it to the level of sulfide for the synthesis of cysteine, methionine, coenzymes and for iron-sulfur clusters of enzymes. This reaction sequence from sulfate to sulfide is called assimilatory sulfate reduction as opposed to dissimilatory sulfate reduction which occurs in certain anaerobic organisms such as *Desulfovibrio* and *Desulfotomaculum*, where sulfate functions as an acceptor for electrons during oxidation of organic substrates and where reduced forms of sulfur are excreted into the surroundings (59, 70, 74, 75, 107).

Assimilatory sulfate reduction has been regularly reviewed (3, 74, 83, 95, 117, 118). In the present review special stress will be put on key reactions and the regulation and localization of the pathway in higher plants. The discussion of the key reactions will follow the established lines of the reaction sequence which involves i) activation of sulfate, ii) transfer of the activated sulfate to a carrier and iii) reduction to the level of sulfide (75, 107).

Figure 1 summarizes the reactions which have been proposed to be involved in assimilatory sulfate reduction of higher plants. A first activation step of sulfate is catalyzed by ATP sulfurylase (EC 2.7.7.4). The adenosine 5'-phosphosulfate (APS) formed is the substrate for adenosine 5'-phosphosulfate kinase (APS kinase; EC 2.7.1.2.5) which forms adenosine 3'-phosphate 5'-phosphosulfate (PAPS) in a second activation step.

Two types of sulfotransferases have been described: APS sulfotransferase transfers the sulfate activated in APS to an as yet unidentified carrier molecule (CarSH) thus forming bound sulfite (CarS-SO<sub>3</sub><sup>-</sup>). PAPS sulfotransferase reacts with PAPS and reduced thioredoxin (tr(SH)<sub>2</sub>) to form sulfite, oxidised thioredoxin (trS<sub>2</sub>) and adenosine 3'-phosphate 5'-phosphate (PAP). Sulfite can also be formed, when CarS-SO<sub>3</sub><sup>-</sup> reacts with a suitable thiol (RSH).

The reduction of sulfite to the level of sulfide may involve sulfite reductase which acts on free sulfite, to form free sulfide, or organic thiosulfate reductase, which uses carrier-bound sulfite (CarS-SO<sub>3</sub><sup>-</sup>) as a substrate and forms carrier-bound sulfide (CarS-S<sup>-</sup>). For both types of reductases, reduced ferredoxin (fd<sub>red</sub>) has been shown to be the electron donor. The two reduction steps thus involve either free or bound intermediates and have been termed correspondingly (74, 75).

## Activation of sulfate by ATP sulfurylase

### Measurement

ATP sulfurylase (ATP: sulfate adenylyltransferase) catalyses the reaction (31, 44, 69):

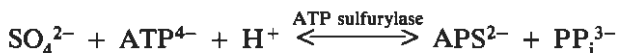

Adenosine 5'-phosphosulfate (APS) and inorganic pyrophosphate are formed from SO<sub>4</sub><sup>2-</sup> and ATP.

Because of the unfavourable equilibrium for APS synthesis and because ac-



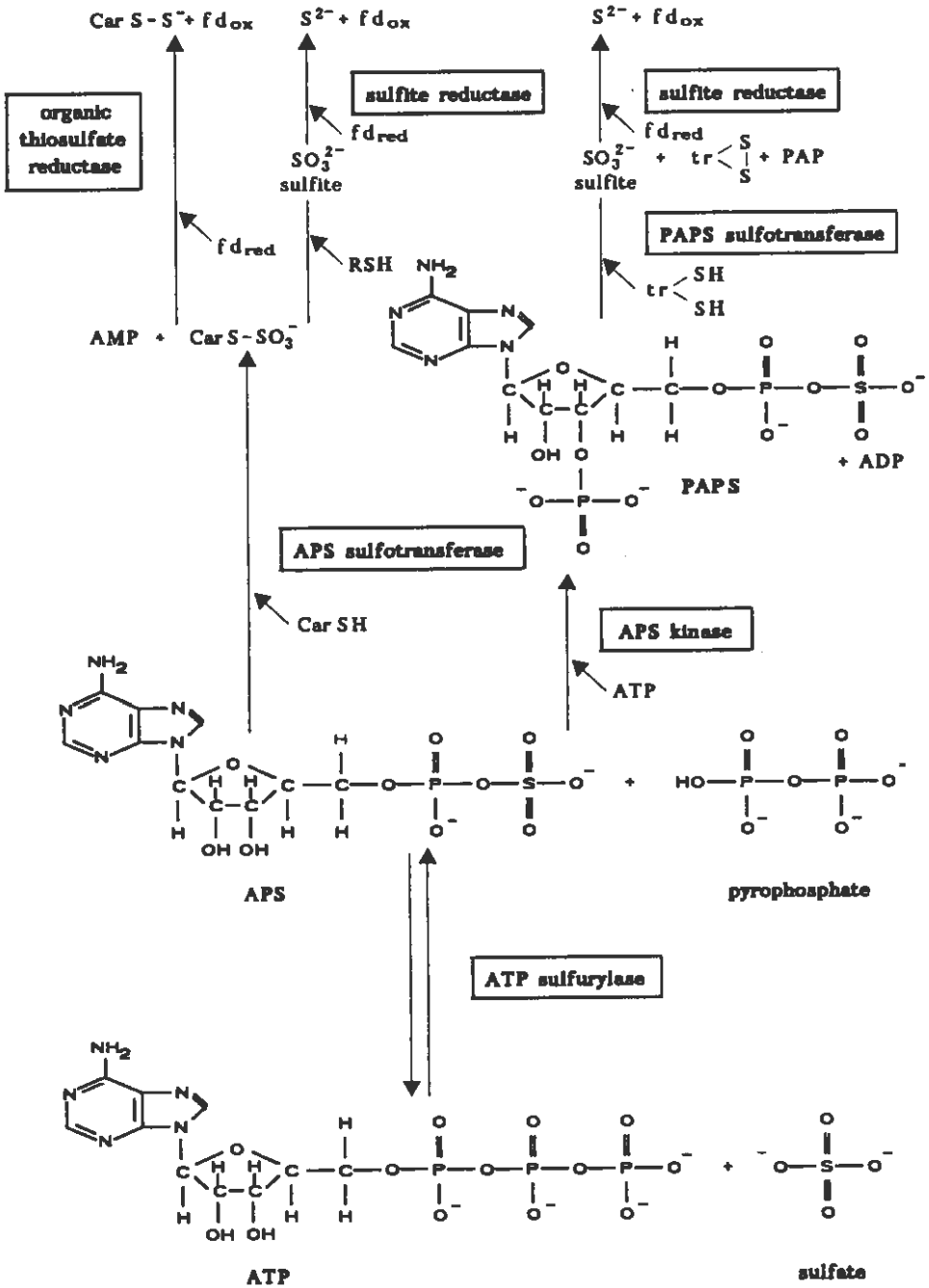

Fig. 1. Possible reactions of assimilatory sulfate reduction in higher plants. Explanation is given in the text. APS, adenosine 5'-phosphosulfate; PAPS, adenosine 3'-phosphate 5'-phosphosulfate; PAP, adenosine 3'-phosphate 5'-phosphate;  $\text{fd}_{\text{red}}$ ,  $\text{fd}_{\text{ox}}$ , reduced and oxidized ferredoxin;  $\text{tr(SH)}_2$ ,  $\text{tr(S)}_2$ , reduced and oxidized thioredoxin;  $\text{CarS-SO}_3^-$ ,  $\text{CarS-S}^-$ , carrier-bound sulfite and sulfide.

cumulating APS inhibits the reaction, measurement of product formation requires highly sensitive methods. Normally, radioactive  $^{35}\text{SO}_4^{2-}$  is used as a substrate and the  $^{35}\text{S}$ -APS formed is separated from the incubation mixture (33, 44, 66, 135). All these separation procedures are timeconsuming and require working with relatively high radioactivities.

ATP sulfurylase also catalyses the reaction of ATP with molybdate and similar anions (135) to form AMP and  $\text{PP}_i$ . Endogenous or added pyrophosphatase splits  $\text{PP}_i$  to  $2\text{P}_i$  which can be used as a measure of enzyme activity.

Methods which use the backreaction for determining ATP sulfurylase without the use of radioactive substrates include the highly sensitive detection of the ATP formed using a luciferin-luciferase system in an ATP-meter or a scintillation counter (8, 87). Another coupled assay system containing hexokinase and glucose and glucose-6-P dehydrogenase and NADP uses the NADPH formed as a measure for the enzyme activity (15).

### *Distribution*

ATP sulfurylase is most probably ubiquitous (31) and has been demonstrated in animals, plants and microorganisms.

### *Properties*

ATP sulfurylase has been purified from several organisms, including higher plants (7, 57, 104). It has a  $K_{\text{eq}}$  of about  $10^{-8}$  (69) and is inhibited by APS ( $K_i$  approximately  $1\mu\text{M}$ ). The enzyme from cabbage (*Brassica capitata* L.) leaves is an asymmetric dimer composed of 57,000 dalton subunits (57).

## **Formation of adenosine 3'-phosphate 5'-phosphosulfate (PAPS) by adenosine 5'-phosphosulfate (APS) kinase**

### *Measurement*

APS kinase (ATP: 5'-adenylylsulfate 3'-phosphotransferase) catalyses the following reaction:



The APS kinase activity can be measured by coupling the formation of ADP to the oxidation of NADH (14), using pyruvate kinase, NAD and lactic dehydrogenase. The decrease in absorbance at 340 nm is a measure for APS kinase activity. The enzyme was also measured by using a bioluminescence method (110) or by HPLC, using  $^{35}\text{S}$ -labelled APS as substrate (97).

### *Distribution*

APS kinase is probably a ubiquitous enzyme (31) which has been demonstrated in several higher plants (13, 50, 110, 127).

### Properties

The APS kinase from *Chlamydomonas* is activated by reduced thioredoxin (99). APS kinase is inhibited by APS, but this inhibition seems much more pronounced in the enzyme from microorganisms than the one from spinach (14) which has maximal activity at 100  $\mu\text{M}$  APS and is inhibited at higher concentrations. For *Chlamydomonas* (99) inhibition of APS kinase starts at 60-100 and 10-16  $\mu\text{M}$  APS in the presence or absence, respectively, of reduced thioredoxin. APS kinase has a very low  $K_m$  for APS, e.g. about 2  $\mu\text{M}$  for the enzyme from *Chlamydomonas* (45).

### Sulfotransferase reactions

#### APS sulfotransferase

##### Measurement

APS sulfotransferase (adenylsulfate: thiol sulfotransferase) catalyses the transfer of the sulfo group of APS to a carrier thiol (CarSH) (76):



The physiological carrier thiol may be glutathione in *Chlorella* (122) or a larger molecule in spinach. Phytochelatins (( $\gamma$ -glutamyl cysteine) $_n$  - glycine,  $n = 3-7$ ) which may have a function in sequestering heavy metals (40), have also been proposed as carrier thiols (111). In *in-vitro* systems dithiols like dithiothreitol (DTT) or monothiols like glutathione (GSH) were applied (121). With DTT, APS sulfotransferase produces free sulfite (121):



Sulfite can also be produced with monothiols in two steps (107, 121):

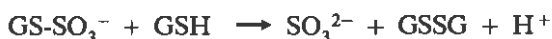

APS sulfotransferase activity is most conveniently measured by using radioactive  $^{35}\text{S}$ -APS and a dithiol. The  $^{35}\text{SO}_3^{2-}$  produced in the enzyme reaction is distilled into a base trap after addition of carrier  $\text{SO}_3^{2-}$  and acidification of the incubation mixture. The trapped radioactivity is used as a measure of APS sulfotransferase activity (24, 73).

##### Distribution

APS sulfotransferase activity has been detected in many higher plants (79), in algae, in cyanobacteria (76, 82, 120) and in *Euglena* (18). This enzyme is thought to be the predominant sulfotransferase in higher plants as well as in most other oxygenic eucaryotes (76, 79, 82). Certain cyanobacteria, however, use PAPS as sulfonyl donor for the sulfotransferase reaction (82).

## Properties

APS sulfotransferase from higher plants is an unstable enzyme (78, 81). It has been partially purified from spinach (81) and *Chlorella* (121). The enzyme from spinach has a  $K_m$  for APS of 10  $\mu\text{M}$ . Its molecular weight is 110,000.

## PAPS sulfotransferase

### Measurement

PAPS sulfotransferase catalyses the transfer of the sulfo group of PAPS to a suitable thiol carrier (136), which may be the dithiol thioredoxin ( $\text{tr}(\text{SH})_2$ ) *in vivo* (93, 100, 123). With thioredoxin the following reactions were proposed (107):

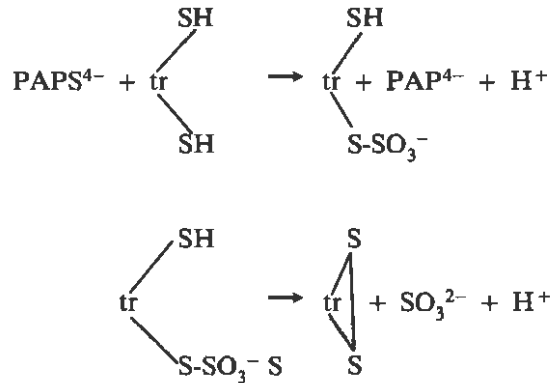

An alternative reaction mechanism recently proposed on the basis of results from *E. coli* and yeast involves i) reduction of the PAPS sulfotransferase by reduced thioredoxin, followed by ii) reduction of PAPS to  $\text{SO}_3^{2-}$  and PAP (100, 124). According to this reaction mechanism the enzyme was termed PAPS reductase (93, 100, 123). Reduced thioredoxin functions as a cofactor rather than as a carrier. Strong evidence in support of the reductase mechanism comes from experiments with the enzyme from *E. coli* (124) which can react with PAPS and form sulfite after reduction with and separation from thioredoxin. The identical mechanism may be relevant with the plant enzyme and renaming will be necessary consequently. In the present review the term PAPS sulfotransferase is used throughout.

PAPS sulfotransferase is most conveniently measured according to the procedure used for APS sulfotransferase but using  $^{35}\text{S}$ -PAPS as a substrate and thioredoxin as a reductant (93, 100).

### Distribution

PAPS sulfotransferase activity has been detected in bacteria (123), cyanobacteria (82), and spinach (97). This enzyme is thought to be the only or the predominant sulfotransferase in bacteria (107) and certain cyanobacteria. It remains to be seen what role it may play in assimilatory sulfate reduction of higher plants and algae as compared to APS sulfotransferase.

## Properties

PAPS sulfotransferase from spinach (93) has a molecular weight of 68,000 to 72,000. The enzyme reduces PAPS only when thioredoxin is present in the assay mixture.

## Reduction

### *Sulfite reductase*

#### Measurement

Sulfite reductase (EC 1.8.7.1) catalyses the ferredoxin- dependent (fd) reduction of sulfite to sulfide (2, 43, 46, 107, 115, 129):



There are many organisms, however, where sulfite reductase (EC 1.8.1.2) uses reduced pyridine nucleotide as reductant (47, 107).

Sulfite reductase can be estimated by i) determining the  $\text{S}^{2-}$  formed using methylene blue formation as a measure (106, 115), ii) using radioactive  $^{35}\text{S}\text{-SO}_3^{2-}$  and measuring the radioactive sulfide and iii) measuring the  $\text{S}^{2-}$  formed using an  $\text{S}^{2-}$  electrode (53, 54). Since it has been shown that  $\text{S}^{2-}$  accumulating in the incubation mixture inhibits sulfite reductase (131) an assay system for sulfite reductase was recently developed in which the  $\text{S}^{2-}$  is reacted with O-acetyl-L-serine to form cysteine (129). Cysteine determined with an acid ninhydrin reagent is used as a measure for sulfite reductase activity.

#### Distribution

Sulfite reductase has been detected in different plants (2, 43, 46, 72, 90, 98, 114, 115, 130), and it seems reasonable to assume that this enzyme is generally present in higher plants.

## Properties

The most detailed information is available of sulfite reductase from spinach leaves (2, 46). The enzyme is composed of subunits with a molecular weight of 69,000 (46) to 71,000 (2). The native enzyme has been assumed to have two (46) or four (2) subunits. It contains one mol of sirohaem and one  $\text{Fe}_4\text{S}_4$  center per subunit. The sulfite reductase catalyses the ferredoxin- or methylviologen-dependent reduction of both  $\text{SO}_3^{2-}$  and  $\text{NO}_2^-$ . The  $K_m$  for  $\text{SO}_3^{2-}$  is at least two orders of magnitude less than with  $\text{NO}_2^-$ , indicating that the physiological reaction catalysed by the enzyme is sulfite reduction. The lowest  $K_m$  for  $\text{SO}_3^{2-}$  published for sulfite reductase from spinach is  $6\mu\text{M}$ . (2).

### *Organic thiosulfate reductase*

#### Measurement

Organic thiosulfate reductase (formerly called thiosulfonate reductase) catalyses the

reduction of carrier-bound sulfite to carrier-bound sulfide, using reduced ferredoxin (fd) as an electron donor (77, 85, 86):



The enzyme can be measured using radioactive sulfogluta-thione ( $\text{GS-}^{35}\text{SO}_3^-$ ) as carrier-bound sulfite and by measuring the radioactive sulfide ( $^{35}\text{S}^{2-}$ ) liberated by exchange with nonradioactive  $\text{S}^{2-}$  from  $\text{GS-}^{35}\text{S}$  and distilled into a  $\text{Cd}^{2-}$  trap after acidification of the assay mixture. The radioactivity of the  $^{35}\text{S-CdS}$  serves as a measure of the enzyme activity (77, 85, 86). A more convenient method for measuring organic thiosulfate reductase involves using  $\text{S}_2\text{O}_4^{2-}$  and the electron-carrying dye methylviologen (77) in the assay system and determining the produced  $\text{H}_2\text{S}$  after distillation as methylene blue. It seems clear, however, that this reaction also measures sulfite reductase (107), so that it can only be used unambiguously for measuring organic thiosulfate reductase when sulfite reductase has been separated.

#### Distribution and properties

Organic thiosulfate reductase has been detected in spinach and *Chlorella* (77, 85, 86). The enzyme from *Chlorella* has a molecular weight of more than 200,000. With  $\text{fd}_{\text{red}}$  and  $\text{GS-}^{35}\text{SO}_3^-$  as substrates, organic thiosulfate reductase forms  $\text{GS-}^{35}\text{SH}$ .

#### Localization

A stimulation of sulfate assimilation by light has been described in many systems (6, 38, 114, 134). These observations prompted experiments with intact chloroplasts to examine whether these organelles could reduce sulfate to the thiol level. Indeed, Schmidt and Trebst (84, 119) showed a light-dependent formation of radioactive cysteine from radioactive  $\text{SO}_4^{2-}$  by isolated spinach chloroplasts. Their results were confirmed by other groups (51, 53, 92, 96). When chloroplasts were examined for the presence of enzymes of assimilatory sulfate reduction, ATP sulfurylase (7, 39, 96), APS kinase (13, 28, 50), APS sulfotransferase (35), organic thiosulfate reductase (94) and sulfite reductase (49, 72) were detected. With this set of enzymes chloroplasts are able of forming PAPS and of reducing sulfite either in the free form or bound to a carrier. Indications that both types of reduction with either free or bound sulfite may be operative come from experiments with extracts from spinach chloroplasts (92). These extracts were incubated with  $^{35}\text{S-APS}$  and concentrations of glutathione which were close to 3.5mM detected in chloroplasts (36). In a light-, glutathione- and ferredoxin-dependent reaction,  $^{35}\text{S-cysteine}$  was formed by these extracts. Half maximal rates of  $^{35}\text{S-cysteine}$  formation were obtained at approximately 3mM glutathione. When the assay system was analysed after the incubation, sulfite bound to glutathione ( $\text{GS-SO}_3$ ) as well as free sulfite could be detected. This finding indicates that glutathione may have two functions in the incubation mixture: a) as an acceptor for the sulfotransferase reaction (76, 122) and b) as a reductant in the formation of free sulfite (78, 107, 122). A concentration of  $3.5\mu\text{M } ^{35}\text{SO}_3^{2-}$  could be determined in the assay system. The experiments with the extracts from spinach chloroplasts show that  $^{35}\text{S-cysteine}$  can be formed from  $^{35}\text{S-APS}$  directly

without prior phosphorylation to PAPS, since the label of  $^{35}\text{S}$ -APS was not diluted appreciably by addition of non-radioactive PAPS. The radioactivity from  $^{35}\text{S}$ -PAPS, however, was diluted to a great extent by nonradioactive APS, indicating that prior to entering the sulfotransferase reaction, PAPS was dephosphorylated to APS, which is the true substrate in this system (76). Thioredoxin had no effect on cysteine formation from APS, even though different types of thioredoxins (60, 138) were used. These results seem to exclude PAPS as a sulfonyl donor in the transferase reaction of spinach chloroplasts. It should be stressed, however, that optimal conditions may not have been present for detecting an eventual PAPS sulfotransferase reaction.

The intracellular localization of the thioredoxin-dependant PAPS sulfotransferase from spinach leaves (93) is not clear. If, like APS sulfotransferase, it should turn out to be a chloroplast enzyme, the relative contribution of the two enzymes to assimilatory sulfate reduction in chloroplasts will need to be resolved.

Most, if not all of the ATP sulfurylase and APS sulfotransferase of green leaves is detected in chloroplasts (35, 39). In the leaves of  $\text{C}_4$ -plants (15, 39, 89) ATP sulfurylase and APS sulfotransferase activities are predominantly or even exclusively present in the bundle sheath cells. Sulfite reductase activity occurs in the mesophyll cells of maize leaves at 50% of the level of bundle sheath cells (90). In contrast, the enzymes catalysing nitrate reduction, nitrate reductase (EC 1.6.6.1) and nitrite reductase (EC 1.7.7.1) are localized predominantly or exclusively in the mesophyll cells of various  $\text{C}_4$ -plants (52, 61) including maize (42, 61, 90). These findings taken together with the distribution of the enzymes of assimilatory sulfate reduction lead to the following conclusions: Nitrogen arriving in the leaves as  $\text{NO}_3^-$  is reduced to  $\text{NO}_2^-$  and  $\text{NH}_4^+$  in the mesophyll cells. The sulfite reductase localized in the bundle sheath cells only takes part in nitrate assimilation when  $\text{NO}_2^-$ , produced by nitrate reductase from  $\text{NO}_3^-$  or formed from atmospheric  $\text{NO}_x$  reaches these cells. In contrast, the sulfite reductase of mesophyll cells may be active in nitrate assimilation to varying degrees depending on the  $\text{NO}_2^-$  concentrations present. Significant assimilatory sulfate reduction can only take place in the bundle sheath cells because the enzymes catalysing the first steps are exclusively or almost exclusively present in these cells. Sulfite reduction in mesophyll cells may become of physiological importance when  $\text{SO}_2$  is taken up from a polluted atmosphere (occurring as  $\text{HSO}_3^-$  or  $\text{SO}_3^{2-}$  in the plants) and is reduced to  $\text{S}^{2-}$  in substantial amounts. Both mesophyll and bundle sheath cells contain O-acetyl-L-serine sulphydrylase (EC 4.2.99.8) (89) activity, which catalyses the formation of cysteine from  $\text{S}^{2-}$  and O-acetyl-L-serine (Fig. 2).

Under normal conditions roots do not seem to contribute appreciably to the needs of plants for reduced sulfur. Reduced sulfur compounds are absent from xylem sap or present only in low concentrations (58). This is consistent with the finding that the level of APS sulfotransferase of sunflower roots was at 5% of the level in shoots (80), that ATP sulfurylase activity of soybean seedlings is at 5 to 10 times higher levels in the leaves than in the roots (1), and that sulfite reduction in pea seedlings occurs predominantly in the leaves as compared to roots (49). This situation changes dramatically, when roots are exposed to increased levels of heavy metals and start synthesising phytochelatins which needs high amounts of cysteine (55, see *Regulation*). It may also be different in young seedlings, because substantial amounts of the activity of all enzymes of assimilatory sulfate reduction were detected in the roots of 5 days old pea plants (24). ATP sulfurylase, APS sulfotransferase and sulfite

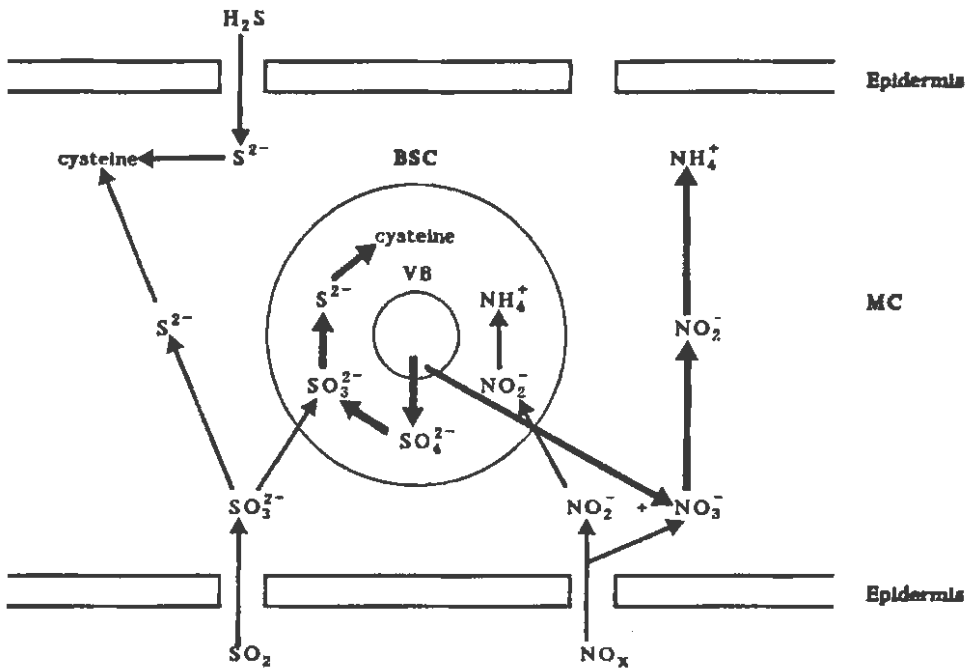

Fig. 2. Intercellular localization of assimilatory sulfate and nitrate reduction in maize leaves. BSC = bundle sheath cells; MC = mesophyll cells; VB = vascular bundle. The reactions indicated are localized on the basis of the distribution of the enzymes involved. The contribution of the epidermis cells to assimilatory sulfate reduction is not clear.

reductase activity from the roots were distributed on sucrose density very similarly as nitrite reductase activity, an enzyme localized in the proplastids. This indicates that these three enzymes of sulfate assimilation have the same intracellular localization. It is perhaps interesting in relation to intracellular localization of assimilatory sulfate reduction in roots that *Euglena* mitochondria synthesize cysteine from sulfate (71) using APS as sulfonyl donor (18).

## Regulation

In theory the concentration of reduced sulfur compounds in organisms capable of assimilatory sulfate reduction can be regulated in the following ways:

- regulation of sulfate uptake,
- regulation of the enzymes of assimilatory sulfate reduction,
- oxidation of reduced sulfur compounds,
- emission of reduced sulfur compounds into the surroundings.

Regulation of sulfate uptake is discussed in detail by Cram (this volume). The emission and oxidation of reduced sulfur compounds will only be discussed briefly here, the main emphasis is being placed on the regulation of enzyme activities.

Emission of reduced sulfur as hydrogen sulfide has been studied in detail. De Cor-



mis showed, that leaves fumigated with injurious concentrations of sulfur dioxide release hydrogen sulfide into the atmosphere (30). It was found later that emission of hydrogen sulfide represents 7 to 15% of the sulfur dioxide taken up (116). Emission of hydrogen sulfide was also observed in response to high sulfate and L-cysteine concentrations (64, 102, 137). The hydrogen sulfide released after sulfur dioxide treatment can best be explained by assuming reduction via sulfite reductase (64, 101). Direct release of sulfide from carrier-bound sulfide has been proposed for the emission of hydrogen sulfide in response to sulfate (64). Emission of reduced organic sulfur compounds has been reported with cell cultures of *Nicotiana tabacum*, which build up glutathione concentrations of 0.7 mM in the nutrient solution (11, 62).

The oxidation of reduced sulfur compounds has been studied with intact plants, extracts from plants and isolated mitochondria (9, 16, 48, 108, 112, 132, 133). It is not clear, whether this oxidation is coupled to energy conservation.

Work on the regulation of the enzymes of assimilatory sulfate reduction shows that these enzymes are affected

- during development,
- by the sulfate concentration in the medium,
- by the presence of  $\text{SeO}_4^{2-}$  and  $\text{MoO}_4^{2-}$  in the medium,
- by APS, 5'-AMP and 5'-ADP,
- by reduced sulfur compounds like  $\text{H}_2\text{S}$ ,  $\text{SO}_2$  and cysteine,
- by nitrogen nutrition.

Regulatory effects were described in which the activity of these enzymes and/or their level in the plant material were affected. A central point of control is occupied by ATP sulfurylase. As already mentioned this enzyme activity is inhibited by APS, its product (126). ATP sulfurylase activity is also affected by 5'-AMP and 5'-ADP. The two nucleotides inhibit the enzyme from spinach (96, 104). ATP sulfurylase from rice roots is inhibited by 5'-ADP and activated by 5'-AMP (56).

APS sulfotransferase activity from spinach and maize is inhibited competitively by 5'-AMP (81). This inhibition may be of physiological relevance: When the concentration of the nucleotide is decreased during a transition from darkness to light (81) an increase in APS sulfotransferase activity should result. An additional increase may result from the light-induced increase in pH in the stroma of the chloroplasts where the enzyme is localized (35), because the enzyme has a high pH optimum (81).

The inhibition of sulfite reductase by sulfide (50% by  $18\mu\text{M}$ ) may be important in situations where the acceptor for sulfide, O-acetyl-L-serine, is not available (130), because it could lessen the accumulation of toxic concentrations of  $\text{S}^{2-}$ . In the presence of the acceptor the O-acetyl-L-serine sulfhydrylase present in extracts from chloroplasts (131) incorporates essentially all  $\text{S}^{2-}$  into cysteine.

The extractable activity of ATP sulfurylase, APS sulfotransferase and sulfite reductase increased in line with chloroplast development when etiolated spinach, bean or pea seedlings were transferred from dark to light (35, 88, 131, 139). These observations are consistent with the localization of the enzyme in chloroplasts. During development of the primary leaves of beans (*Phaseolus vulgaris*) and peas (*Pisum sativum*) ATP sulfurylase and APS sulfotransferase activity increased till the leaf was fully developed, then both enzyme activities decreased to very low levels even though

ribulosebiphosphate carboxylase activity was still at high levels (88, 131). These findings indicate that in these leaves assimilatory sulfate reduction is no longer operating once they are completely developed. This was corroborated by experiments where primary leaves of beans (*Phaseolus vulgaris*) which were detached and incubated with  $^{35}\text{SO}_4^{2-}$  at various times during development (88): The *in vivo* assimilation of  $^{35}\text{SO}_4^{2-}$  decreased in proportion to the two enzyme activities. A rapid decrease in ATP sulfurylase and APS sulfotransferase activity was also detected in primary leaves of *Phaseolus vulgaris* during dark-induced senescence (91). The sequence of events during senescence of beech (*Fagus sylvatica* L.) and wheat leaves may be different because APS sulfotransferase activity decreased later than ribulosebiphosphate carboxylase activity (17, 32).

Generally both ATP sulfurylase and APS sulfotransferase activity of leaves increase under conditions of sulfur deprivation (1, 4, 10, 23, 89). The effect is normally more pronounced in cell cultures than in plants (12, 41, 141). High sulfate concentrations decrease APS sulfotransferase activity from *Lemna minor* (23), which may be due to the fact that parallel to the increase in plant sulfate there is an increase in non-protein thiols. In *Lemna minor*, *Phaseolus vulgaris* and cell cultures of *Rosa* sp. and *Nicotiana sylvestris*,  $\text{H}_2\text{S}$  and cysteine decrease APS sulfotransferase activity to very low levels (19, 20, 21, 41, 139). These responses may indicate that the enzyme is synthesized at a decreased rate when a reduced sulfur source is available in addition to/or instead of sulfate. Indeed, density labelling experiments using  $^{15}\text{NO}_3^-$  with *Lemna minor* showed that in the presence of  $\text{H}_2\text{S}$  the production of APS sulfotransferase molecules is decreased (128).

From the ecological point of view the effect of  $\text{SO}_2$  on the regulation of assimilatory sulfate reduction may be more important. A decrease in both ATP sulfurylase and APS sulfotransferase would be expected when  $\text{SO}_2$  is available to plants and is reduced as  $\text{SO}_3^{2-}$  to  $\text{S}^{2-}$  by sulfite reductase. Indeed, a substantial decrease of APS sulfotransferase activity was detected in *Phaseolus vulgaris*, *Fagus sylvatica* and *Picea abies* leaves fumigated with low concentrations of  $\text{SO}_2$  (22, 125, 140). ATP sulfurylase in *Fagus sylvatica* (22) and *Picea abies* (125) was not affected very significantly, indicating that the level of this enzyme is less subjected to regulatory signals from reduced sulfur compounds. This effect was detected before (33, 76) and may be due to the fact that ATP sulfurylase also catalyses the first step of sulfolipid synthesis (27, 28, 71).

Several studies have established regulatory interactions between assimilatory sulfate and nitrate assimilation (10, 25, 29, 37, 41, 62, 113, 141). Based on results with cultured cells of tobacco a scheme has been proposed (67, 68) in which each pathway is regulated down by its own internal signals when the other pathway is not limiting. This type of regulation is combined with a regulation by positive signals originating in the other pathway, thus establishing a coordination of both pathways. Since they converge in the synthesis of proteins, this coordinate regulation can be envisaged as a mechanism aimed at the production of appropriate amounts of amino acids and sulfur amino acids. The effects of varying sulfur and nitrogen nutrition are especially clearly evident with cell cultures. In sulfate sufficient cell cultures of tobacco (67, 68) ATP sulfurylase activity increased at a rate corresponding to the initial  $\text{NO}_3^-$ -concentration. The enzyme from *Ipomea* cell cultures increased with  $\text{NH}_4^+$  and  $\text{NO}_3^-$  as nitrogen sources as compared to cultures with  $\text{NO}_3^-$ , whereas lack of a nitrogen source decreased enzyme activity to 80% of the controls within 24 h (141).

The effects of nitrogen and sulfur sources on nitrate reductase, ATP sulfurylase and APS sulfotransferase have also been studied in cell cultures of *Rosa* sp. (41). Without a sulfur source APS sulfotransferase activity increased by 200% and nitrate reductase activity decreased to 30% as compared to controls. ATP sulfurylase activity was not affected. Omission of a nitrogen source did not affect ATP sulfurylase, whereas nitrate reductase and APS sulfotransferase decreased substantially. These results seem to indicate that APS sulfotransferase activity is regulated much more effectively than ATP sulfurylase activity by the sulfur and the nitrogen source in *Rosa*.

Plants cultivated with Cd can produce large amounts of phytochelatins (40). Since these compounds contain much cysteine (40), Cd might be expected to enhance the levels of the enzymes of assimilatory sulfate reduction. Indeed, ATP sulfurylase and APS sulfotransferase activity was high in roots of maize seedlings cultivated with  $50\mu\text{M Cd}^{2+}$  (55). In the leaves, a significant positive effect of  $\text{Cd}^{2+}$  was detected at  $5\mu\text{M}$  for ATP sulfurylase activity and at 5 and  $20\mu\text{M}$  for APS sulfotransferase. At higher concentrations both enzyme activities were at levels below the control which may be due to the fact that growth was almost completely inhibited and that premature senescence may be involved.

Taken together the enzyme levels in assimilatory sulfate reduction demonstrate that conditions of high demand stimulate the pathway whereas decreased demand or addition of exogenous sources of reduced sulfur compounds decrease sulfur flux.

### Concluding remarks

“It is probably fair to state that knowledge of sulfur metabolism has lagged behind knowledge of carbon, nitrogen and phosphorus metabolism. This lag is no doubt due to less intrinsic interest as well as such practical considerations as the instability of sulfur compounds”. This statement of Thompson (117) has lost none of its relevance for assimilatory sulfate reduction. The most intriguing open questions in this field which remain for future work are

- the physiological significance of the enzyme reactions detected *in vitro*, especially of the APS sulfotransferase versus the PAPS sulfotransferase pathway and of the organic thiosulfate reductase versus the sulfite reductase mechanism,
- the detailed characterization of APS sulfotransferase and PAPS sulfotransferase,
- the molecular basis of the regulatory phenomena observed,
- the contribution of the root system to assimilatory sulfate reduction.

The methods of molecular biology could be of great help for answering some of these questions. The fact that they have been used successfully in the related field of assimilatory nitrate reduction (26) will hopefully prompt workers in the field of assimilatory sulfate reduction of higher plants to proceed along similar lines.

### Acknowledgments

I thank J. Danzeisen and Th. Brunold for their help in preparing this review and J.D. Schwenn and H. Rennenberg for providing preprints of their work.

## Literature cited

1. Adams, C.A. and Rinne, R.W. 1969. Influence of age and sulfur metabolism on ATP sulfurylase activity in the soybean and survey of selected species. *Plant Physiol.* 44: 1241-1245.
2. Aketagawa, J. and Tamura, G. 1980. Ferredoxin-sulfite reductase from spinach. *Agric. Biol. Chem.* 44: 2371-2378.
3. Anderson, J.W. 1980. Assimilation of inorganic sulfate into cysteine. In: *Biochemistry of plants*, Milfin, B.J. ed., pp. 203-225, Academic Press, New York.
4. Archer, M.J. 1987. Effect of differential sulfur nutrition on the specific activity of ATP sulfurylase in mature grain from five wheat cultivars (*Triticum aestivum* L.). *Aust. J. Plant Physiol.* 14: 239-244.
5. Arnoldt, R.I. and de Meio, R.D. 1941. The conjugation of phenol and the action of phenol on the respiration of tissues in vitro. *Rev. Soc. Argent. Biol.* 17: 570-574.
6. Asahi, T. 1960. Reduction of sulfite to sulfide in mung bean leaf. *J. Biochem. (Tokyo)* 48: 548-556
7. Balharry, G.J.E. and Nicholas, D.J.D. 1970. ATP-sulphurylase in spinach leaves. *Biochem. Biophys. Acta* 220: 513-524.
8. Balharry, G.J.E. and Nicholas, D.J.D. 1971. New assay for ATP-sulphurylase using the luciferin-luciferase method. *Anal. Biochem.* 40: 1-17.
9. Ballantyne, D.J. 1977. Sulphite oxidation by mitochondria from green and etiolated peas. *Phytochem.* 16: 49-50.
10. Barney, P.E. and Bush, L.P. 1985. Interaction of nitrate and sulfate reduction in tobacco. *J. Plant Nutrition* 8: 505-515.
11. Bergmann, L. and Rennenberg, H. 1978. Efflux und Produktion von Glutathion in Suspensionskulturen von *Nicotiana tabacum*. *Z. Pflanzenphysiol.* 88: 175-185.
12. Bergmann, L., Schwenn, J.D. and Urlaub, H. 1980. Adenosine triphosphate sulfurylase and O-acetylserine sulphydrylase in photoheterotrophically and heterotrophically cultured tobacco cells. *Z. Naturforsch.* 35c: 952-957.
13. Burnell, J.N. and Anderson, J.W. 1973. Adenosine 5'-sulphatophosphate kinase activity in spinach leaf tissue. *Biochem. J.* 134: 565-579.
14. Burnell, J.N. and Whatley, F.R. 1975. A new, rapid and sensitive assay for adenosine 5'-phosphosulphate (APS) kinase. *Anal. Biochem.* 68: 281-288.
15. Burnell, J.N. 1984. Sulfite assimilation in C<sub>4</sub> plants. Intercellular and intracellular location of ATP sulfurylase, cysteine synthase and cystathionine  $\beta$ -lyase in maize leaves. *Plant Physiol.* 75: 873-875.
16. Brunold, C. 1972. Regulation der Sulfataufnahme und der Sulfatassimilation durch Schwefelwasserstoff bei *Lemna minor* L. Thesis University of Bern, Switzerland.
17. Brunold, C. 1983. Changes in ATP sulfurylase and adenosine 5'-phosphosulfate sulfotransferase activity during autumnal senescence of beech leaves. *Physiol. Plant.* 59: 319-323.
18. Brunold, C. and Schiff, J.A. 1976. Studies of sulfate utilization by algae. 15. Enzymes of assimilatory sulfate reduction in *Euglena* and their cellular localization. *Plant Physiol.* 57: 430-436.
19. Brunold, C. and Schmidt, A. 1976. Regulation of adenosine-5-phosphosulfate sulfotransferase activity by H<sub>2</sub>S in *Lemna minor* L. *Planta* 133: 85-88.
20. Brunold, C. and Schmidt, A. 1978. Regulation of sulfate assimilation in plants. 7. Cysteine inactivation of adenosine 5'-phosphosulfate sulfotransferase in *Lemna minor* L. *Plant Physiol.* 61: 342-347.
21. Brunold, C., Zryd, J.-P. and Lavanchy, P. 1981. Regulation of enzymes of assimilatory sulfate reduction in aerated cell suspension cultures of *Nicotiana sylvestris*. *Plant Sci. Lett.* 21: 167-174.
22. Brunold, C., Landolt, W. and Lavanchy, P. 1983. SO<sub>2</sub> and assimilatory sulfate reduction in beech leaves. *Physiol. Plant.* 59: 313-318.
23. Brunold, C., Suter, M. and Lavanchy, P. 1987. Effect of high and low sulfate concentrations on adenosine 5'-phosphosulfate sulfotransferase activity from *Lemna minor* L. *Physiol. Plant.* 70: 168-174.
24. Brunold, C. and Suter, M. 1989. Localization of enzymes of assimilatory sulfate reduction in pea roots. *Planta* 179: 228-234.
25. Cacco, G., Saccomani, M., Ferrari, G. 1983. Changes in the uptake and assimilation efficiency for sulfate and nitrate in maize hybrids selected during the period 1930 through 1975. *Physiol. Plant.* 58: 171-174.
26. Crawford, N.M., Campbell, W.H. and Davis, R.W. 1986. Nitrate reductase from squash cDNA cloning and nitrate regulation. *Proc. Natl. Acad. Sci. USA* 83: 8073-8076.
27. Davies, N.H., Mercer, E.I. and Goodwin, T.W. 1965. The occurrence and intracellular distribution

- of the plant sulfolipid in maize, runner beans, plant tissue cultures, and *Euglena gracilis*. *Phytochem.* 4: 741-749.
28. Davies, N.H., Mercer, E.I. and Goodwin, T.W. 1966. Some observations on the biosynthesis of the plant sulfolipid by *Euglena gracilis*. *Biochem. J.* 98: 369-373.
  29. Deboer, D.L. and Duke, S.H. 1982. Effects of sulphur nutrition on nitrogen and carbon metabolism in lucerne (*Medicago sativa* L.). *Physiol. Plant.* 54: 343-350.
  30. De Cormis, L. 1968. Dégagement d'hydrogène sulfurisé par des plantes soumises à une atmosphère contenant de l'anhydride sulfureux. *C.R. Acad. Sci. Ser. D.* 266: 683-685.
  31. De Meio, R.H. 1975. Sulfate activation and transfer. In: *Metabolic pathways VII. The metabolism of sulfur compounds*. Greenberg, D.M. ed. pp. 287-358. Academic Press, New York.
  32. Egger, A. 1989. Einfluss von Ozon auf physiologische Parameter von Sommerweizen (*Triticum aestivum* cv. Albis) im Freiland- und Laborversuchen. Thesis, University of Bern, Switzerland.
  33. Ellis, R.J. 1969. Sulphate activation in higher plants. *Planta* 88: 34-42.
  34. Erismann, K.H. and Brändle, R. 1968. Schwefelwasserstoff-Aufnahme und Verwertung durch paraschierte Blätter. *Flora, Abt. A.* 159: 379-382.
  35. Fankhauser, H. and Brunold, C. 1978. Localization of adenosine 5'-phosphosulfate sulfotransferase in spinach leaves. *Planta* 143: 285-289.
  36. Foyer, C.H. and Halliwell, B. 1976. The presence of glutathione and glutathione reductase in chloroplasts: a proposed role in ascorbic acid metabolism. *Planta* 133: 21-25.
  37. Friedrich, J.W. and Schrader, L.E. 1978. Sulfur deprivation and nitrogen metabolism in maize seedlings. *Plant Physiol.* 61: 900-903.
  38. Fromageot, P. and Perez-Milan, M. 1959. Réduction du sulfate en sulfite par la feuille de tabac. *Biochim. Biophys. Acta* 32: 457-464.
  39. Gerwick, B.C., Ku, S.B. and Black, C.C. 1980. Initiation of sulfate activation: a variation in C4 photosynthesis plants. *Science* 209: 513-515.
  40. Grill, E., Winnacker, E.L. and Zenk, M.H. 1985. Phytochelatins: the principal heavy-metal complexing peptides of higher plant. *Science* 230: 674-676.
  41. Haller, E., Suter, M. and Brunold, C. 1986. Regulation of ATP-sulfurylase and adenosine 5'-phosphosulfate sulfotransferase by the sulfur and the nitrogen source in heterotrophic cell suspension cultures of Paul's Scarlet rose. *J. Plant Physiol.* 125: 275-283.
  42. Harel, E., Lea, P.J. and Mifflin, B.J. 1977. Localization of enzymes of nitrogen assimilation in maize leaves and their activities during greening. *Planta* 134: 195-200.
  43. Hennies, H.H. 1975. A ferredoxin-linked sulfite reductase from *Spinacia oleracea*. *Z. Naturforsch.* 30c: 359-362.
  44. Hiltz, H. and Lipmann, F. 1955. The enzymatic activation of sulfate. *Proc. Natl. Acad. Sci.* 41: 880-890.
  45. Jender, H.G. and Schwenn, J.D. 1984. Purification and properties of ATP: adenylylsulphate 3'-phosphotransferase from *Chlamydomonas reinhardtii*. *Arch. Microbiol.* 138: 9-14.
  46. Krueger, R.J. and Siegel, L.M. 1982. Evidence for siroheme-Fe<sub>4</sub>S<sub>4</sub> interaction in spinach ferredoxin-sulfite reductase. *Biochemistry* 21: 2905-2909.
  47. Lee, J.P., LeGall, J. and Peck, H.D. Jr. 1973. Isolation of assimilatory- and dissimilatory-type sulfite reductases from *Desulfovibrio vulgaris*. *J. Bact.* 115: 529-542.
  48. Maggioni, A. and Renosto, F. 1977. Cysteine and methionine regulation of sulfate uptake in potato tuber discs (*Solanum tuberosum*). *Plant Physiol.* 39: 143-147.
  49. Mayer, A.M. 1967. Subcellular location of sulphite reductase in plant tissues. *Plant Physiol.* 42: 324-326.
  50. Mercer, E.I. and Thomas, G. 1969. The occurrence of ATP-adenylylsulphate 3'-phosphotransferase in the chloroplasts of higher plants. *Phytochemistry* 8: 2281-2285.
  51. Mills, W.R. and Wilson, K.G. 1978. Amino acid biosynthesis in isolated pea chloroplasts: metabolism of labeled aspartate and sulfate. *FEBS Lett.* 92: 129-132.
  52. Moore, R. and Black, C.C. 1979. Nitrogen assimilation pathways in leaf mesophyll and bundle sheath cells of C<sub>4</sub> photosynthesis plants formulated from comparative studies with *Digitaria sanguinalis* L. Scop. *Plant Physiol.* 64: 309-313.
  53. Ng, B.H. and Anderson, J.W. 1979. Light dependent incorporation of selenite and sulphite into selenocysteine and cysteine by isolated chloroplasts. *Phytochem.* 18: 573-580.
  54. Ngo, T.T. and Shargool, P.D. 1973. The use of a sulfide ion selective electrode to study O-acetylserine sulphydrylase from germinating rapeseed. *Anal. Biochem.* 54: 247-261.

55. Nussbaum, S., Schmutz, D. and Brunold, C. 1988. Regulation of assimilatory sulfate reduction by cadmium in *Zea mays* L. *Plant Physiol.* 88: 1407-1410.
56. Onajobi, F.D. 1975. Effects of adenine nucleotides on rice-root adenosine triphosphate sulphurylase activity in vivo. *Biochem. J.* 149: 301-304.
57. Osslund, T., Chandler, C. and Segel, I.H. 1982. ATP sulfurylase from higher plants. Purification and preliminary kinetics studies on the cabbage leaf enzyme. *Plant Physiol.* 70: 39-45.
58. Pate, J.S. 1965. Roots as organs of assimilation of sulfate. *Science* 149: 547-548.
59. Peck, H.D. Jr. 1959. The ATP-dependent reduction of sulfate with hydrogen in extracts of *Desulfovibrio desulfuricans*. *Proc. Natl. Acad. Sci. USA* 45: 701-708.
60. Porque, P.G., Baldesten, A. and Reichard, P. 1970. The involvement of the thioredoxin system in the reduction of methionine sulfoxide and sulfate. *J. Biol. Chem.* 245: 2371-2374.
61. Rathnam, C.K.M. and Edwards, G.E. 1976. Distribution of nitrate-assimilating enzymes between mesophyll protoplasts and bundle sheath cells in leaves of three groups of  $C_4$  plants. *Plant Physiol.* 57: 881-885.
62. Rennenberg, H. and Bergmann, L. 1979. Einfluss von Ammonium und Sulfat auf die Glutathion Produktion in Suspensionskulturen von *Nicotiana tabacum*. *Z. Pflanzenphysiol.* 92: 133-142.
63. Rennenberg, H. 1983. Role of O-acetylserine in hydrogen sulfide emission from pumpkin leaves in response to sulfate. *Plant Physiol.* 73: 560-565.
64. Rennenberg, H. 1989. Synthesis and emission of hydrogen sulfide by higher plants. In: Biogenic sulfur in the environment, Saltzman, E.S. and Cooper, W.J. eds., ACS Sym. Ser. 393, pp. 44-57, Amer. Chem. Soc., Washington DC.
65. Renosto, F., Seubert, P.A. and Segel, I.H. 1984. Adenosine 5'-phosphosulfate kinase from *Penicillium chrysogenum*. *J. Biol. Chem.* 259: 2113-2123.
66. Reuveny, Z. and Filner, P. 1976. A new assay for ATP sulfurylase based on differential solubility of the sodium salts of adenosine 5'-phosphosulfate and sulfate. *Anal. Biochem.* 75: 410-428.
67. Reuveny, Z. and Filner, P. 1977. Regulation of ATP sulfurylase in cultured tobacco cells. *J. Biol. Chem.* 252: 1858-1864.
68. Reuveny, Z., Dougall, D.K. and Trinity, P.M. 1980. Regulatory coupling of nitrate and sulfate assimilation pathways in cultured tobacco cells. *Proc. Natl. Acad. Sci. USA* 77: 6670-6672.
69. Robbins, P.W. and Lipmann F. 1958b. Enzymatic synthesis of adenosine-5'-phosphosulfate. *J. Biol. Chem.* 233: 686-690.
70. Roy, A.B. and Trudinger, P.A. 1970. The biochemistry of inorganic compounds of sulphur. University Press, Cambridge.
71. Saidha, T., Na, S.-Q., Li, J. and Schiff, J.A. 1988. A sulphate metabolizing centre in *Euglena* mitochondria. *Biochem. J.* 253: 533-539.
72. Sawhney, S.K. and Nicholas, D.J.D. 1975. Nitrite, hydroxylamine and sulphite reductases in wheat leaves. *Phytochem.* 14: 1499-1503.
73. Schiff, J.A. and Levinthal, I.M. 1968. Studies of sulfate utilization by algae. 4. Properties of a cell-free sulfate-reducing system from *Chlorella*. *Plant Physiol.* 43: 547-554.
74. Schiff, J.A. and Hudson, R.C. 1973. The metabolism of sulfate. *Annu. Rev. Plant Physiol.* 24: 381-414.
75. Schiff, J.A. 1983. Reduction and other metabolic reactions of sulfate. In: Encyclopedia Plant Physiol., New Series 15A, Inorganic plant nutrition, Läuchli, A. and Bielecki, R.L. eds. pp. 402-421, Springer, Berlin.
76. Schmidt, A. 1972. On the mechanism of photosynthetic sulfate reduction. An APS-sulfotransferase from *Chlorella*. *Arch. Microbiol.* 84: 77-86.
77. Schmidt, A. 1973. Sulfate reduction in a cellfree system of *Chlorella*. The ferredoxin dependent reduction of a protein-bound intermediate by a thiosulfonate reductase. *Arch. Microbiol.* 93: 29-52.
78. Schmidt, A. 1975. A sulfotransferase from spinach leaves using adenosine-5'-phosphosulfate. *Planta* 124: 267-275.
79. Schmidt, A. 1975. Distribution of APS-sulfotransferase activity among higher plants. *Plant Sci. Lett.* 5: 407-415.
80. Schmidt, A. 1976. Development of adenosine-5'-phosphosulfate-sulfotransferase in sunflower (*Helianthus annuus* L.). *Z. Pflanzenphysiol.* 78: 164-168.
81. Schmidt, A. 1976. The adenosine-5'-phosphosulfate sulfotransferase from spinach (*Spinacea oleracea* L.). Stabilization, partial purification and properties. *Planta* 130: 257-263.
82. Schmidt, A. 1977. Assimilatory sulfate reduction via 3'-phosphoadenosine-5'-phosphosulfate (PAPS) and adenosine-5'-phosphosulfate (APS) in blue-green algae. *FEMS Microbiol. Lett.* 1: 137-140.

83. Schmidt, A. 1986. Regulation of sulfur metabolism in plants. *Progress in Botany* 48: 133-150.
84. Schmidt, A. and Trebst, A. 1969. The mechanism of photosynthetic sulfate reduction by isolated chloroplasts. *Biochem. Biophys. Acta* 180: 529-535.
85. Schmidt, A. and Schwenn, J.D. 1971. On the mechanism of photosynthetic sulfate reduction. In: *Proc. 2nd int. Congr. photosynthesis research*, Forti, O., Arron, M. and Melandri, A. eds. pp. 507-514, Junk, The Hague.
86. Schmidt, A., Abrams, W.R. and Schiff, J.A. 1974. Reduction of adenosine 5'-phosphosulfate to cysteine in extracts from *Chlorella* and mutants blocked for sulfate reduction. *Eur. J. Biochem.* 47: 423-434.
87. Schmutz, D. and Brunold, C. 1982. Determination of ATP-sulfurylase in crude extracts of *Phaseolus vulgaris* L. using the luciferin-luciferase-system. *Anal. Biochem.* 121: 151-155.
88. Schmutz, D. and Brunold, C. 1982. Regulation of sulfate assimilation in plants XIII. Assimilatory sulfate reduction during ontogenesis of primary leaves of *Phaseolus vulgaris* L. *Plant Physiol.* 70: 524-527.
89. Schmutz, D. and Brunold, C. 1984. Intercellular localization of assimilatory sulfate reduction in leaves of *Zea mays* and *Triticum aestivum*. *Plant Physiol.* 74: 866-870.
90. Schmutz, D. and Brunold, C. 1985. Localization of nitrite and sulfite reductase in bundle sheath and mesophyll cells of maize leaves. *Physiol. Plant.* 64: 523-528.
91. Schmutz, D., Wyss, H.-R. and Brunold, C. 1983. Activity of sulfate-assimilating enzymes in primary leaves of *Phaseolus vulgaris* L. during dark-induced senescence. *Z. Pflanzenphysiol.* 110: 211-219.
92. Schürmann, P. and Brunold, C. 1980. Formation of cysteine from adenosine 5'-phosphosulfate (APS) in extracts from spinach chloroplasts. *Z. Pflanzenphysiol.* 100: 257-268.
93. Schwenn, J.D. 1989. Sulfate assimilation in higher plants: a thioredoxin-dependent PAPS-reductase from spinach leaves. *Z. Naturforsch.* 44c: 504-508.
94. Schwenn, J.D. and Hennies, H.H. 1974. Enzymes and bound intermediates involved in photosynthetic sulfate reduction of spinach chloroplasts and *Chlorella*. In: *Proc. 3rd inter. congress on photosynthesis*, pp 629-635, Rehovot.
95. Schwenn, J.D. and Trebst, A. 1976. Photosynthetic sulfate reduction by chloroplasts. In: *The intact chloroplast*, Barber, J. ed. pp. 315-334. Elsevier/North Holland Biomedical Press, Amsterdam.
96. Schwenn, J.D. and Depka, B. 1977. Assimilatory sulfate reduction by chloroplasts: The regulatory influence of adenosine-mono- and adenosine-diphosphats. *Z. Naturforsch.* 32c: 792-797.
97. Schwenn, J.D. and Jender, H.G. 1981. A kinetic investigation of the APS-kinase from *Chlamydomonas reinhardtii*. *Phytochemistry* 20: 601-604.
98. Schwenn, J.D. and Kemena, A. 1984. Expression of the plant sulphite reductase in cell suspension cultures from *Catharanthus roseus* L. *Planta* 160: 151-158.
99. Schwenn, J.D. and Schriek, U. 1984. A new role for thioredoxin in assimilatory sulfate reduction. Activation of the adenylsulfate kinase from the green alga *Chlamydomonas reinhardtii*. *FEBS Lett.* 170: 76-80.
100. Schwenn, J.D., Krone, F. and Husmann, K. 1988. Yeast PAPS-reductase: properties and requirements of the purified enzyme. *Arch. Microbiol.* 150: 313-319.
101. Sekiya, J., Wilson, L.G. and Filner, P. 1982. Resistance to injury by sulfur dioxide. *Plant Physiol.* 70: 437-441.
102. Sekiya, J., Schmidt, A., Rennenberg, H., Wilson, L.G. and Filner, P. 1982. Hydrogen sulfide emission by cucumber leaves in response to sulfate in light and dark. *Phytochemistry* 21: 2173-2178.
103. Seubert, P.A., Renosto, F., Knudson, P. and Siegel, I.H. 1985. Adenosinetriphosphate sulfurylase from *Penicillium chrysogenum*: steady-state kinetics of the forward and reverse reactions, alternative substrate kinetics, and equilibrium binding studies. *Arch. Biochem. Biophys.* 240: 509-523.
104. Shaw, W.H. and Anderson, J.W. 1972. Purification, properties and substrate specificity of adenosinetrisphosphate sulphurylase from spinach leaf tissue. *Biochem. J.* 127: 237-247.
105. Shaw, W.H. and Anderson, J.W. 1973. Kinetic studies and a proposed reaction mechanism for spinach leaf ATP sulphurylase. *Proc. Austr. Biochem. Soc.* 6: 21.
106. Siegel, L.M. 1965. A direct microdetermination for sulfide. *Anal. Biochem.* 11: 126-132.
107. Siegel, L.M. 1975. Biochemistry of the sulfur cycle. In: *Metabolic pathways*, Greenberg, D.M., ed. pp. 217-286, Academic Press, New York.
108. Smith, I.K. 1976. Characterization of sulfate transport in cultured tobacco cells. *Plant Physiol.* 58: 358-362.
109. Smith, I.K. 1980. Regulation of sulfate assimilation in tobacco cells. *Plant Physiol.* 66: 877-883.
110. Stanley, P.E., Kelley, B.C., Tuovinen, O.H. and Nicholas. D.J.D. 1975. A bioluminescence method

- for determining adenosine 3'-phosphate 5'-phosphate (FAP) and adenosine 3'-phosphate 5'-sulfatophosphate (PAPS) in biological materials. *Anal. Biochem.* 67: 540-551.
111. Steffens, J.D., Hunt, D.F. and Williams, B.G. 1986. Accumulation of non-protein metal-binding polypeptides ( $\gamma$ -glutamyl-cysteinyl) $_n$ -glycine in selected cadmium resistant tomato cells. *J. Biol. Chem.* 261: 13879-13882.
112. Strickland, R.G. 1961. Oxidation of reduced pyridine nucleotides and of sulphite by pea root mitochondria. *Nature* 190: 648.
113. Suter, M., Lavanchy, P., von Arb, C. and Brunold, C. 1986. Regulation of sulfate assimilation by amino acids in *Lemna minor* L. *Plant Sci.* 44: 125-132.
114. Tamura, G. 1965. Studies on the sulfite reducing system of higher plants. II. Purification and properties of sulfite reductase from *Allium odorum*. *J. Biochem. (Tokyo)* 57: 207-214.
115. Tamura, G., Hosoi, T. and Aketagawa, J. 1978. Ferredoxin-dependent sulfite reductase from spinach leaves. *Agri. Biol. Chem.* 42: 2165-2167.
116. Taylor, G.E. and Tingey, D.T. 1983. Sulfur dioxide flux into leaves of *Geranium carolinianum* L. Evidence for a nonstomatal or residual resistance. *Plant Physiol.* 72: 237-244.
117. Thompson, J.F. 1967. Sulfur metabolism in plants. *Annu. Rev. Plant Physiol.* 18: 59-84.
118. Thompson, J.F., Smith, I.K. and Madison, J.T. 1986. Sulfur metabolism in plants. In: *Sulfur in agriculture*, Tabatabai, M.A. ed. pp. 57-122, American Society of Agronomy, Madison.
119. Trebst, A. and Schmidt, A. 1969. Photosynthetic sulfate and sulfite reduction by chloroplasts. In: *Progr. photosyn. res.* III, Metzner, H. ed. pp. 1510-1516, Tübingen.
120. Tsang, M.L.-S. and Schiff, J.A. 1975. Studies of sulfate utilization by algae 14. Distribution of adenosine 5'-phosphosulfate (APS) and adenosine 3'-phosphate 5'-phosphosulfate (PAPS) sulfotransferase in assimilatory sulfate reducers. *Plant Sci. Lett.* 4: 301-307.
121. Tsang, M.L.-S. and Schiff, J.A. 1976. Studies of sulfate utilization by algae 17. Reactions of adenosine 5'-phosphosulfate (APS) sulfotransferase from *Chlorella* and studies of model reactions which explain the diversity of side products with thiols. *Plant Cell Physiol.* 17: 1209-1220.
122. Tsang, M.L.-S. and Schiff, J.A. 1978. Studies of sulfate assimilation by algae 18. Identification of glutathione as a physiological carrier in assimilatory sulfate reduction by *Chlorella*. *Plant Sci. Lett.* 11: 177-183.
123. Tsang, M.L.-S. 1981. Assimilatory sulfate reduction in *Escherichia coli*: identification of the alternate cofactor for adenosine 3'-phosphate 5'-phosphosulfate reductase as glutaredoxin. *J. Bacteriol.* 146: 1059-1066.
124. Tsang, M.L.-S. 1983. Function of thioredoxin in the reduction of adenosine 3'-phosphate 5'-phosphosulfate in *Escherichia coli*. In: *Thioredoxins - structure and functions*, Gadal, P. ed. pp. 103-110, CNRS, Paris.
125. Tschanz, A., Landolt, W., Bleuler, P. and Brunold, C. 1986. Effect of SO<sub>2</sub> on the activity of adenosine 5'-phosphosulfate sulfotransferase from spruce trees (*Picea abies*) in fumigation chambers and under field conditions. *Physiol. Plant.* 67: 235-241.
126. Tweedie, J.W. and Segel, I.H. 1971. Adenosine triphosphate sulfurylase from *Penicillium chrysogenum*. II. Physical, kinetic and regulatory properties. *J. Biol. Chem.* 246: 2438-2446.
127. Urlaub, H. and Jankowski, G. 1982. Sulfate reduction in *Catharanthus roseus* L. Identification and subcellular localization of a particulate adenosine 5'-phosphosulfate-reducing activity in cells from cell suspension cultures. *Planta* 155: 154-161.
128. von Arb, C. and Brunold, C. 1980. Analysis of the regulation of adenosine 5'-phosphosulfate sulfotransferase activity in *Lemna minor* L. using <sup>15</sup>N-density labeling. *Planta* 149: 355-360.
129. von Arb, C. and Brunold, C. 1983. Measurement of ferredoxin-dependent sulfite reductase activity in crude extracts from leaves using O-acetyl-L-serine sulfhydrylase in a coupled assay system to measure the sulfide formed. *Anal. Biochem.* 131: 198-203.
130. von Arb, C. and Brunold, C. 1985. Ferredoxin-sulfite reductase and ferredoxin-nitrite reductase activities in leaves of *Pisum sativum*: changes during ontogeny and in vitro regulation by sulfide. *Physiol. Plant.* 64: 290-294.
131. von Arb, C. and Brunold, C. 1986. Enzymes of assimilatory sulfate reduction in leaves of *Pisum sativum*: activity changes during ontogeny and in vivo regulation by H<sub>2</sub>S and cysteine. *Physiol. Plant.* 67: 81-86.
132. Weigl, J. and Ziegler, H. 1962. Die räumliche Verteilung von <sup>35</sup>S und die Art der markierten Verbindungen in Spinatblättern nach Begasung mit <sup>35</sup>SO<sub>2</sub>. *Planta* 58: 435-447.
133. Wetter, L.B. 1964. Biosynthesis of mustard oil glucosides II. The administration of sulphur-35-compounds to horse-radish leaves. *Phytochem.* 3: 57-64.



134. Willenbrink, J. 1964. Lichtabhängiger  $^{35}\text{S}$ -Einbau in organische Bindung von Tomatenpflanzen. Z. Naturforsch. 19b: 356-357.
135. Wilson, L.G. and Bandurski, R.S. 1958. Enzymatic reactions involving sulfate, sulfite, selenate and molybdate. J. Biol. Chem. 233: 975-981.
136. Wilson, L.G. and Bierer, D. 1976. The formation of exchangeable sulphite from adenosine 3'-phosphate 5'-sulphatophosphate in yeast. Biochem. J. 158: 255-270.
137. Wilson, L.G., Bressan, R.A. and Filner, P. 1978. Light-dependent emission of hydrogen sulfide from plants. Plant Physiol. 61: 184-189.
138. Wolosiuk, R.A., Crawford, N.A., Yee, B.C. and Buchanan, B.B. 1979. Isolation of three thioredoxins from spinach leaves. J. Biol Chem. 254: 1627-1632.
139. Wyss, H.-R. and Brunold, C. 1979. Regulation of adenosine 5'-phosphosulfate sulfotransferase activity by  $\text{H}_2\text{S}$  and cyst(e)ine in primary leaves of *Phaseolus vulgaris* L. Planta 147: 37-42.
140. Wyss, H.-R. and Brunold, C. 1980. Regulation of adenosine 5'-phosphosulfate sulfotransferase by sulfur dioxide in primary leaves of beans (*Phaseolus vulgaris* L.). Physiol. Plant. 50: 161-165
141. Zink, M.W. 1984. Regulation of ATP-sulfurylase by various nitrogen and sulfur sources in cultured *Ipomoea* sp. Can. J. Bot. 62: 2107-2113

# REGULATORY ASPECTS OF CYSTEINE AND METHIONINE BIOSYNTHESIS

John Giovanelli<sup>1</sup>

*Laboratory of General and Comparative Biochemistry, National Institute of Mental Health, Bethesda, Maryland 20892, U.S.A.*

## Contents

Introduction	33
Regulatory aspects of cysteine synthesis	34
– Scope of review	34
– Regulation of cysteine biosynthesis by availability of O-acetylserine	35
– Regulation of steady-state concentration of cysteine	36
– Emission of H <sub>2</sub> S	36
– Glutathione metabolism	36
Regulatory aspects of methionine synthesis	36
Scope of review	36
Early working model for regulation of methionine biosynthesis	37
Problems with early working model	40
– Threonine does not play a key role in regulation of methionine biosynthesis	41
– Lysine does not play a key role in regulation of methionine biosynthesis	41
Revised scheme for regulation of methionine biosynthesis	44
Implications of revised scheme	45
Acknowledgement	46
Literature cited	46

## Introduction

Plants play a crucial role in the cycling of sulfur in Nature. Man and other non-ruminants require a dietary source of methionine, and convert this essential amino acid ultimately to inorganic sulfate *via* homocysteine and cysteine. Plants complete the cycle by assimilation of inorganic sulfate first into cysteine, then into homocysteine and methionine. Plants thus provide the ultimate source of methionine in most animal diets (15).

Cysteine and methionine are the major end products of sulfate assimilation in plants, comprising up to 90% of the total sulfur of most plants (1, 16). These two amino acids are present predominantly (99% or more) in protein form (1, 16). Certain plants are unusual in that the nonprotein fraction may also contain a variety of sulfur amino acids such as S-methylmethionine sulfonium salt, homomethionine, djenkolic

<sup>1</sup> Present address: Laboratory of Neurochemistry, Building 36, Room 3D30, National Institute of Mental Health, Bethesda, Maryland 20892, U.S.A.

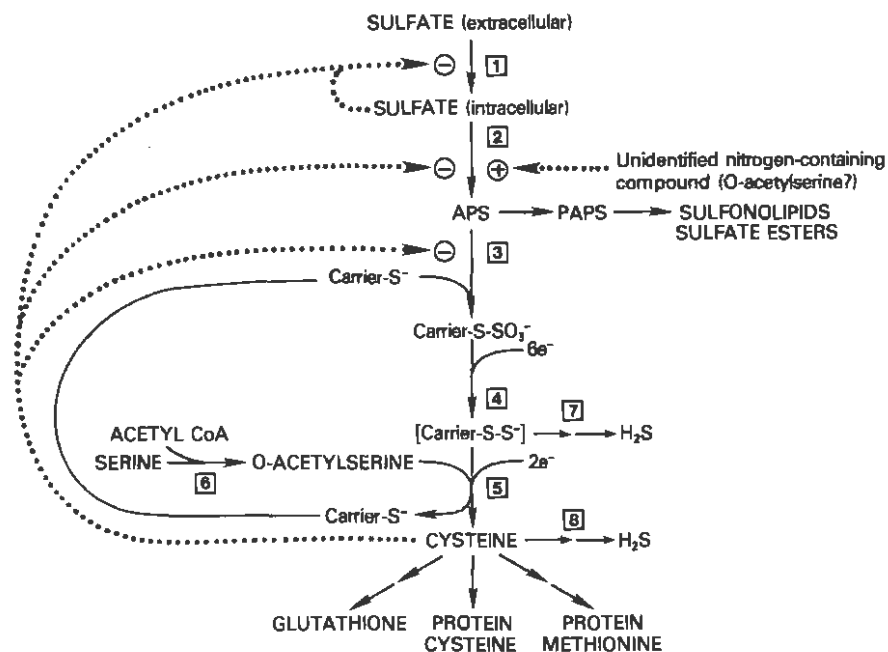

**Fig. 1.** Proposed regulatory patterns of cysteine biosynthesis. The reactions are as follows: 1, sulfate uptake system; 2, sulfate adenylyltransferase; 3, adenosine 5'-sulfatophosphate (APS) sulfotransferase; 4, thiosulfonate reductase; 5, cysteine synthase; 6, serine acetyltransferase; 7, release of sulfide from carrier-bound sulfide; 8, desulfhydration of cysteine, e.g. by cysteine desulfhydrase. PAPS = 3'-phosphate adenosine 5'-sulfatophosphate. For simplicity, not all substrates and products have been included. Solid arrows show reactions (pathways). Dotted arrows indicate proposed negative (-) or positive (+) regulatory effects. Studies with *Chlorella* mutants indicate that the carrier-bound pathway illustrated is used *in vivo* rather than an alternate pathway in which free sulfite is reduced to free sulfide by sulfite reductase. Glutathione may function as the carrier in plants, at least in *Chlorella*. Reduced ferredoxin provides the source of electrons for Reaction 4. Bound sulfide is shown in brackets since its identity remains to be established. The reactions involved in assimilation of sulfate have recently been reviewed by Saidha and Schiff (39). Cysteine synthase is assayed with free sulfide, even though this compound may not be the physiological donor. Although this enzyme is inhibited by cysteine and a number of other amino acids of the sulfur assimilation pathway, the high concentrations required suggest these inhibitions are not physiologically significant (16). Because of conflicting findings it is not clear whether repression/derepression of cysteine synthase plays a major role in regulation of cysteine synthesis. Thus, in kidney beans and *Lemna minor*, activities of cysteine synthase have been reported to be insensitive to levels of sulfur nutrition (see 16); in tobacco cells, Smith (41) found the specific activity of cysteine synthase not to be affected by sulfur nutrition, while Bergmann *et al.* (3) reported up to a ten-fold increase in the specific activity of this enzyme during sulfur starvation.

acid, and S-methylcysteine and its  $\gamma$ -glutamyl and sulfoxide derivatives (38). The metabolic functions and biochemistry of these 'unusual' sulfur amino acids have not been clearly defined, and are outside the scope of this review.

### Regulatory aspects of cysteine synthesis

#### Scope of review

A tentative scheme showing potential sites for regulation of cysteine biosynthesis is

given in Fig. 1. *In vivo*, the quantitative significance of the proposed steps and nature of their interactions for regulation of cysteine synthesis remain to be clarified. Evidence for regulation at sulfate uptake (Reaction 1) has been discussed by Cram (see: this volume) and at the steps leading to reduction of sulfate to sulfide (Reactions 2-4) by Brunold (see: this volume). The most likely remaining sites at which regulation of cysteine biosynthesis may occur are briefly discussed below.

#### *Regulation of cysteine biosynthesis by availability of O-acetylserine*

As illustrated in Reaction 6, O-acetylserine synthesis is catalyzed by the enzyme serine acetyltransferase:

serine acetyltransferase



O-Acetylserine is the 3-carbon donor for synthesis of cysteine catalyzed by cysteine synthase (Reaction 5):

cysteine synthase

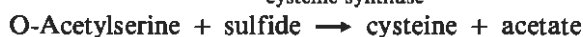

Modulation of serine acetyltransferase is probably not important in regulation of cysteine biosynthesis. This enzyme requires unphysiologically high concentrations of cysteine to inhibit activity (7,42). Further, activities of serine acetyltransferase in roots of kidney beans were not significantly different in plants growing under conditions of sulfur deficiency or with adequate sulfur nutrition (40), indicating that synthesis of this enzyme is probably not feedback controlled by cysteine or other products of sulfur assimilation.

Evidence has been presented that the availability of O-acetylserine may regulate cysteine synthesis, at least in plant cells supplied with excess sulfate (33). Thus, feeding of O-acetylserine to cucurbit cells enhanced incorporation of  $^{35}\text{SO}_4^{2-}$  into cysteine, while reducing the rate of  $\text{H}_2\text{S}$  emission. These effects are consistent with an increased rate of cysteine formation (Reaction 5) competing with the reactions (Pathway 7) leading to  $\text{H}_2\text{S}$  emission. Additional evidence that availability of O-acetylserine may regulate cysteine synthesis is provided by studies with 3-fluoropyruvate, a compound which interferes with synthesis of O-acetylserine by inhibiting formation of acetyl CoA via the reaction catalyzed by the pyruvate dehydrogenase complex. This latter reaction in the mitochondria is believed to be a major source of acetyl CoA in plant cells. The presence of this inhibitor reduced cysteine synthesis, while enhancing emission of  $\text{H}_2\text{S}$ . These findings suggest that the availability of acetyl CoA may be more important in determining the rate of O-acetylserine synthesis than is the modulation of serine acetyltransferase activity. In accordance with this suggestion, it was found that acetyl CoA was as effective as O-acetylserine in causing increased incorporation of  $^{35}\text{SO}_4^{2-}$  into cysteine, and concomitant reduced emission of  $\text{H}_2\text{S}$ .

In bacteria, O-acetylserine is required for derepression of sulfate adenylyltransferase (Reaction 2) (45). Derepression of sulfate adenylyltransferase in tobacco cells requires the presence of a nitrogen-containing compound, as yet unidentified (34). It is an attractive speculation that O-acetylserine also plays this role in plants, thereby regulating cysteine synthesis not only by its requirement as a substrate for cysteine synthase, but also by its requirement for derepression of sulfate adenylyltransferase. Such a regulatory scheme would provide a mechanism for coupling nitrogen assimilation (into O-acetylserine) with sulfur assimilation into cysteine.

### Regulation of steady-state concentration of cysteine

Limited studies (16, 33) indicate that the concentration of cysteine is maintained at very low levels in plants; the concentration of cysteine in *Lemna paucicostata*, for example, is approximately 10  $\mu\text{M}$ . The low steady-state concentrations of cysteine result from a complex balance between reactions that synthesize cysteine and those that utilize this amino acid (Fig. 1). Of the four major reactions of the latter type (Fig. 1), net synthesis of protein, cysteine and methionine would be expected to be relatively inflexible and not to respond to changes in cysteine concentration. Evidence that the two remaining pathways for cysteine utilization, namely emission of  $\text{H}_2\text{S}$  and synthesis of glutathione, play a role in compensating for excesses or deficiencies in cysteine synthesis is presented below.

**Emission of  $\text{H}_2\text{S}$ .** Extensive studies by Rennenberg and coworkers (33) indicate that the pool size of cysteine may be regulated by emission of  $\text{H}_2\text{S}$  from carrier-bound sulfide (Pathway 7) and from cysteine (Reaction 8) by an L-cysteine-specific desulphydrase. Activity of this enzyme was increased by preincubation of leaf discs with L- or D-cysteine, but not with cystine. Details of the processes of  $\text{H}_2\text{S}$  emission and their possible physiological significance in regulation of cysteine biosynthesis have been recently reviewed (33).

**Glutathione metabolism.** Photoheterotrophic tobacco cells incorporate up to 40% of the total assimilated sulfate into glutathione, 99% of which is excreted into the medium (33). On the basis of this and other findings, Rennenberg (33) proposed that glutathione functions as a storage and transport form of sulfur in plants, helping to maintain a constant concentration of cysteine. While such a homeostatic mechanism may operate in tobacco cells, no support for such a role of glutathione synthesis was found in *L. paucicostata* (16). In this plant, inorganic sulfate appears to be the major storage form of sulfur, increasing some 30-fold as the concentration of sulfate in the medium was increased 3000-fold, and accounting for over one-half of the total sulfur in plants cultured at the highest concentration (1 mM) of sulfate.

### Regulatory aspects of methionine biosynthesis

#### Scope of review

Methionine consists of three moieties - methyl, sulfur, and 4-carbon. Each of these moieties is synthesized at different rates, and subject to different regulatory controls (18). *De novo* synthesis of the entire methionine molecule (*i.e.* all three moieties) proceeds *via* transsulfuration to form homocysteine, with subsequent methylation of this amino acid to methionine (Fig. 2). This review will focus exclusively on this pathway, the only one resulting in a net synthesis of the methionine molecule. Other pathways do not result in *de novo* synthesis of the entire methionine molecule. For example, transmethylation results in net utilization only of the methyl moiety of methionine (for synthesis of methylated products), with recycling of the sulfur and 4-carbon moieties. Polyamine and ethylene biosynthesis results in net utilization only of the 4-carbon moiety of methionine, with recycling of the methylthio moiety. As illustrated in Fig. 2, AdoMet<sup>2</sup> is a key intermediate in each of the latter two pathways.

<sup>2</sup> Abbreviations: AdoMet, S-adenosylmethionine; AdoHcy, S-adenosylhomocysteine; PAG, DL-propargylglycine.

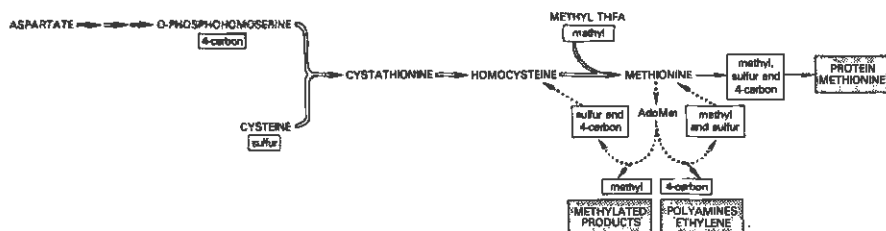

Fig. 2. Major pathways of methionine metabolism. *De novo* synthesis of the entire methionine molecule (i.e. methyl, sulfur, and 4-carbon moieties) is achieved by the reactions (shown by wide arrows) of trans-sulfuration to form homocysteine, and subsequent methylation of this amino acid to methionine. Solid arrows depict synthesis of protein methionine, the major end product of *de novo* methionine biosynthesis. Dotted arrows depict pathways in which methionine is regenerated either by recycling of the sulfur and 4-carbon moieties (in transmethylation, to form phosphatidylcholine, pectin methyl esters, etc.), or of the methylthio moiety (in polyamine and ethylene biosynthesis). Shaded boxes depict major end products of methionine metabolism. For the sake of simplicity, only broad outlines of the pathways are shown, and cycling between methionine and S-methylmethionine sulfonium is omitted; the net effect of turnover of the latter compound is conversion of ATP to adenosine + PP<sub>1</sub> + P<sub>i</sub>. Details of the component reactions and relative fluxes of the pathways have been presented (15, 18).

Obviously a clear understanding of the regulatory mechanisms for net synthesis of methionine is critical for devising strategies to bring about improvement in the methionine content of plant products by molecular genetics, etc. Regulatory schemes for this pathway have been based to a large extent on 'regulatory properties' determined with isolated enzymes, with little attention being paid to determining the significance of these regulatory properties *in vivo*. This review focuses on the *in vivo* aspects of regulation of methionine biosynthesis, and, based on current evidence, arrives at a regulatory scheme that is fundamentally different from those previously presented. The work to be described was performed with the higher plant *Lemna paucicostata*. This plant has many experimental advantages including its rapid clonal growth under axenic and steady-state conditions on defined media (13), and its voracious appetite for supplementary amino acids and other compounds in the culture medium (12).

#### Early working model for regulation of methionine biosynthesis

Before attempting to elucidate how the plant regulates synthesis of methionine, clearly it is important to determine whether in fact this regulation does occur. This question was unequivocally answered in the affirmative in experiments in which *Lemna* was grown in the presence of  $^{35}\text{SO}_4^{2-}$ , and incorporation of  $^{35}\text{S}$  into cysteine on the one hand, and into cystathionine and its products (homocysteine, methionine, AdoMet, S-methylmethionine sulfonium) on the other, was determined (Fig. 3). These assimilation patterns were determined for control plants and for plants growing with supplemental methionine. Incorporation of  $^{35}\text{S}$  into cysteine was essentially identical for control and methionine-supplemented plants. By contrast, entry of  $^{35}\text{S}$  into cystathionine and its products in methionine-supplemented plants was only 20% that of control plants. These findings therefore establish a strong feedback regulation by methionine of its own synthesis, and further indicate that cystathionine  $\gamma$ -synthase is a major regulatory site (17).

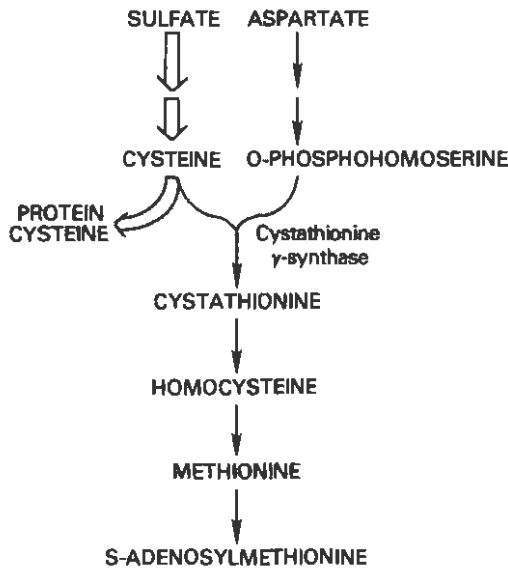

Fig. 3. Effects of methionine supplementation on assimilation of  $^{35}\text{S}$  from  $^{35}\text{SO}_4^{2-}$  into sulfur amino acids. Broad arrows indicate incorporation of  $^{35}\text{S}$  from  $^{35}\text{SO}_4^{2-}$  into cysteine. This incorporation was unaffected by methionine supplementation. By contrast, incorporation of  $^{35}\text{S}$  into cystathionine and its products was decreased by approximately 80% by methionine supplementation. This differential effect on  $^{35}\text{S}$  incorporation strongly implicates the step catalyzed by cystathionine  $\gamma$ -synthase as a regulatory site.

Further studies on levels of cystathionine  $\gamma$ -synthase in *Lemna* growing under varying conditions of methionine nutrition support the regulatory role of this enzyme (44) in methionine biosynthesis. Plants cultured with supplementary methionine showed a progressive reduction in extracted cystathionine  $\gamma$ -synthase activity to approximately 15% that of control plants. Conversely, plants cultured with aminoethoxyvinylglycine or lysine plus threonine each showed progressive increases in cystathionine  $\gamma$ -synthase activity. The latter supplements each result in methionine limitation by inhibiting specific steps in the pathway of methionine biosynthesis (10) - aminoethoxyvinylglycine by irreversible inhibition of  $\beta$ -cystathionase, and the combination of lysine plus threonine by inhibition of aspartokinase, the portal of entry of 4-carbon units into the aspartate family of amino acids. Up to 10-fold differences in specific activities of cystathionine  $\gamma$ -synthase were observed between plants supplemented with methionine, and plants cultured under conditions causing methionine deficiency. These differences appeared specific for cystathionine  $\gamma$ -synthase in that activities of cysteine synthase remained essentially unchanged under the growth conditions described. In these studies, plant extracts were subjected to gel-filtration before assay in order to remove unbound small molecules. This fact, coupled with the finding that none of the possible feedback regulators (methionine, AdoMet, S-methylmethionine sulfonium, etc.) added to the assay affected activity of cystathionine  $\gamma$ -synthase, suggests that the effects observed on the enzyme are not allosteric, but represent repression/derepression, or some form of covalent modification such as phosphorylation, methylation, etc. Whether methionine itself triggers the changes

in cystathionine  $\gamma$ -synthase, or whether a methionine product such as AdoMet acts as a signal, remains to be determined.

The finding that supplementary methionine caused large and comparable decreases in methionine biosynthesis and cystathionine  $\gamma$ -synthase activity could be taken to suggest that changes in cystathionine  $\gamma$ -synthase alone are sufficient for corresponding changes in flux into the methionine branch. However, subsequent studies in which cystathionine  $\gamma$ -synthase was titrated *in vivo* with propargylglycine (PAG), an irreversible suicide inhibitor of this enzyme, showed this suggestion to be an oversimplification (43). In these experiments *Lemna* was grown in the presence of increasing concentrations of PAG, and cystathionine  $\gamma$ -synthase activities compared with rates of methionine biosynthesis. Special precautions were taken to ensure that activities of cystathionine  $\gamma$ -synthase measured in extracts were valid measures of enzyme activities in the plants, *i.e.* that the activities determined were not confounded by inactivation of the enzyme by PAG during extraction. To guard against this, plants were homogenized in the presence of O-succinylhomoserine, a substrate for cystathionine  $\gamma$ -synthase that prevents inactivation by PAG. Extracts were then subjected to gel-filtration twice to ensure removal of PAG, O-succinylhomoserine, and any other low molecular weight materials in the extracts. Surprisingly, it was found that cystathionine  $\gamma$ -synthase activity could be reduced by growth with PAG by over 80% without appreciably affecting the rate of methionine biosynthesis. Reduction of cystathionine  $\gamma$ -synthase by as much as 88% reduced methionine biosynthesis by only 18%. Clearly, reduction of cystathionine  $\gamma$ -synthase alone, obtained by growth with PAG, was not sufficient to regulate flux through the cystathionine  $\gamma$ -synthase step; during growth with methionine other factors must be involved in this reduction.

At the time, it was suggested that these findings might be explained as follows. Inhibition of cystathionine  $\gamma$ -synthase by PAG would be expected to result in an accumulation of the physiological substrate, O-phosphohomoserine. If this enzyme normally operates below saturation with O-phosphohomoserine, an increase in this substrate would result in increased flux through the residual enzyme, thereby helping to overcome the inhibition.

While the effect of PAG is understood to be essentially limited to reduction of cystathionine  $\gamma$ -synthase activity, methionine supplementation can result in a variety of additional effects. These provided the basis for an early working model for regulation of methionine biosynthesis illustrated in Fig. 4 (8, 16, 43). A key factor in this tentative model is that methionine supplementation is known to cause a marked increase (some 10-fold) in the tissue concentration of AdoMet (11, 16); such increases would not be expected in plants growing with propargylglycine. It was proposed that the elevated pool size of AdoMet initiated a series of events: (a) *In vitro* studies demonstrate that AdoMet causes a potent allosteric stimulation of threonine synthase (23, 28). One possible consequence of this would be to divert O-phosphohomoserine from the methionine branch into the threonine branch, resulting in an elevated concentration of soluble threonine. Further conversion of threonine to isoleucine would be expected to be limited by build up of isoleucine, a strong feedback inhibitor of threonine dehydratase (8, 26). (b) Threonine in turn has been demonstrated *in vitro* to be a potent inhibitor of homoserine dehydrogenase (8). Inhibition of homoserine dehydrogenase might not only decrease flux through this step, but also divert aspartic semialdehyde into the lysine branch, resulting in accumulation



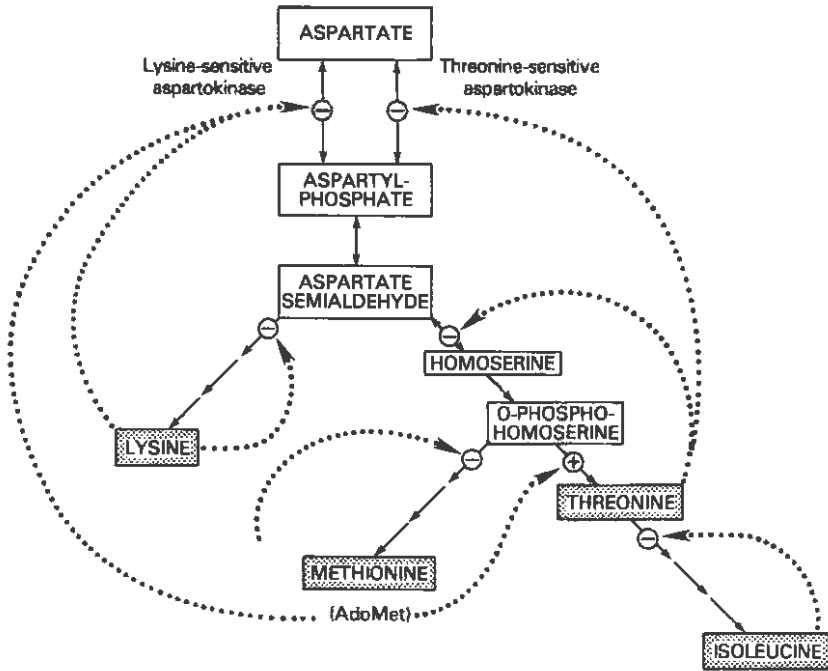

Fig. 4. Early working model for regulation of methionine biosynthesis. Major end products (shown in shaded boxes) accumulate predominantly in protein form. Proposed regulatory effects are shown by dotted arrows directed to stimulation (+) or inhibition (-) of the target site. Target sites are (from top to bottom): lysine- and threonine-sensitive aspartokinase; dihydrodipicolinate synthase (lysine branch); homoserine dehydrogenase (conversion of aspartic semialdehyde to homoserine); cystathionine  $\gamma$ -synthase (methionine branch); threonine synthase (threonine/isoleucine branch); threonine dehydratase (conversion to threonine to isoleucine).

of soluble lysine. (c) Lysine, either alone or synergistically with AdoMet, is a potent inhibitor of lysine-sensitive aspartokinase activity (20, 36). Further reduction of aspartokinase activity could result from the increased concentration of threonine inhibiting threonine-sensitive aspartokinase activity (8, 20). Inhibition of either or both aspartokinase activities could result in decreased flux through this step. (d) The combined effects of feedback regulation of flux at the aspartokinase and/or homoserine dehydrogenase steps could prevent the building up of O-phosphohomoserine that would otherwise overcome the down-regulated activity of cystathionine  $\gamma$ -synthase.

#### Problems with early working model

While the tentative model illustrated in Fig. 4 and basically similar schemes proposed by other workers have been widely accepted, it is emphasized that, of the effects listed above, the only one clearly demonstrated to operate *in vivo* is the accumulation of AdoMet in response to methionine supplementation. All the other proposed effects were based essentially on studies with isolated enzymes. Recent studies outlined below now make it clear that, *in vivo*, neither threonine nor lysine play the central roles proposed in Fig. 4.

*Threonine does not play a key role in regulation of methionine biosynthesis.* Two lines of evidence support this conclusion (19, 21). First, supplementation of *Lemna* with concentrations of methionine causing appreciable feedback regulation of methionine synthesis was accompanied by little if any increases in pool size of soluble threonine, or, within the limits of detection, of soluble lysine. Second, even increases up to 60-fold in the pool size of soluble threonine obtained by culture of *Lemna* with supplementary threonine had no significant effects on net flux of 4-carbon units from aspartate through the aspartokinase or homoserine dehydrogenase steps, or into the threonine/isoleucine branch. The tissue concentration of soluble threonine in these plants was greater than 12 mM, an order of magnitude greater than that required for complete inhibition of threonine-sensitive aspartokinase of *Lemna* (20). The possibility was considered that the proposed regulatory effects of threonine might require the additional presence of isoleucine, as it does in the process of bivalent repression in bacteria (45). This possibility was tested by adding isoleucine to the threonine supplement (19, 21). Again, no decreases in flux were observed. The presence of isoleucine in the supplement did, however, result in a reduction of flux between threonine and isoleucine to less than 10% of its value in control plants, consistent with feedback inhibition by isoleucine at the step catalyzed by threonine dehydratase (8, 26). The possibility was also considered that the absence of appreciable effects of threonine on flux may have resulted from sequestration of supplementary threonine away from the sites of metabolism of the aspartate family of amino acids. This seems unlikely for two reasons. First, high concentrations of soluble threonine generated endogenously in isoleucine-supplemented plants were no more effective in regulation than similar concentrations of threonine accumulated from the medium (19,21). Second, the severe (concerted) inhibition of flux resulting from further addition of lysine to threonine-supplemented cultures (see below) strongly suggests that supplementary threonine does indeed lead to accumulation of this amino acid at sites of metabolism of the aspartate family of amino acids.

These combined findings argue against the proposed regulatory effects of threonine acting at the aspartokinase and homoserine dehydrogenase steps. Absence of major regulation of flux at the homoserine dehydrogenase step is supported by the report (9) that stringent inhibition of homoserine dehydrogenase by threonine was not observed when the assay for this enzyme was performed at a pH with concentrations of substrates more closely approximating *in vivo* conditions.

*Lysine does not play a key role in regulation of methionine biosynthesis.* Studies of incorporation of radioactivity from tracer amounts of  $^{14}\text{C}$ -aspartate into the amino acids of the aspartate family (21) showed that supplementation of *Lemna* with lysine decreased the flux of 4-carbon units into lysine to less than 2% of that of control plants. Reduction of flux into lysine was accompanied by an equivalent molar reduction of flux through aspartokinase. Flux through homoserine dehydrogenase and into the methionine and threonine-isoleucine branches remained unchanged. The specific reduction of flux into the lysine branch provides strong evidence of feedback inhibition by lysine at the first committing step in the lysine branch, namely dihydrodipicolinate synthase. *In vitro* studies have indeed established that lysine is a potent inhibitor of this enzyme (27, 29). The comparable reductions of flux into the lysine branch and through the aspartokinase step could be taken to suggest that lysine inhibition of aspartokinase is regulating flux through this step. However, for the rea-

sons listed below, lysine inhibition of aspartokinase is neither necessary nor sufficient for regulation of entry of 4-carbon units into the aspartate family of amino acids.

Inhibition of aspartokinase is not necessary for the observed reduction of flux through the aspartokinase step, since both aspartokinase (4) and aspartic semialdehyde dehydrogenase (5) catalyze readily reversible steps. Thus, any aspartic semialdehyde and aspartyl phosphate that would tend to accumulate as a result of feedback regulation at the dihydrodipicolinate step can be readily reconverted back to aspartate.

Inhibition of aspartokinase is not sufficient to reduce flux through the aspartokinase step:

(i) Aspartokinase is commonly believed to be 'rate-limiting'<sup>3</sup>, based mainly on reports that its activity is much less than those of other enzymes of the aspartate family of amino acids (35, 37). This property has led investigators to conclude that inhibition of aspartokinase by lysine (or threonine) has a major physiological effect in regulating flux through the aspartokinase step. In contrast, our studies (20, 21) indicate that the maximum capacity ( $V_{max}$ ) of aspartokinase of *Lemna*, and probably of plants in general, is greatly in excess of the *in vivo* flux through the aspartokinase step, so that major changes in aspartokinase activities would have relatively minor effects on fluxes through this step. Aspartokinase activities of gel-filtered extracts of control *Lemna* plants were some 40-fold in excess of the *in vivo* flux through this step. If the combined inhibitions resulting from tissue concentrations of threonine (190  $\mu$ M), lysine (29  $\mu$ M) and AdoMet (15  $\mu$ M) in control plants were taken into account, aspartokinase was present in an order of magnitude excess of its *in vivo* flux. Even with complete inhibition of *either* lysine- or threonine-sensitive forms, activity of the remaining form remained adequate (complete inhibition of lysine-sensitive form) or an order of magnitude more than required (complete inhibition of threonine-sensitive form) for *in vivo* flux through the aspartokinase step. Only with complete inhibition of *both* threonine- and lysine-sensitive activities<sup>4</sup> does aspartokinase fail to provide sufficient activity for *in vivo* flux through this step. While calculations of this sort are clearly subject to considerable error, they do indicate that, rather than being 'rate-limiting', aspartokinase has considerable excess capacity *in vivo*. Corroborative evidence for the large excess capacity of aspartokinase, and a closer quantitative approximation of this excess, was provided by comparison of aspartokinase activities and fluxes through the aspartokinase step for plants supplemented with lysine (21). In these studies, fluxes through aspartokinase were determined from measurements of radioactivity from tracer <sup>14</sup>C-aspartate incorporated into protein amino acids of the aspartate family. This flux was determined to be 65% that of control plants. The total activity and relative proportion of lysine- and threonine-sensitive forms of aspartokinase activity in gel filtered extracts of these plants was essentially identical to that of control plants<sup>5</sup>. The tissue concentration of

<sup>3</sup> As generally recommended (25, 31), the term 'rate-limiting' ('pacemaker', 'bottle neck', etc.) is avoided, and is used here only for the sake of accurate reporting of other workers' conclusions.

<sup>4</sup> About 0.7% of the total aspartokinase activity of *Lemna* was insensitive to inhibition by lysine or threonine (20).

<sup>5</sup> In agreement with studies of Rognes *et al.* (37) with barley, none of the combinations of aspartate family amino acids added as supplements during steady-state growth caused appreciable changes in either lysine- or threonine-sensitive aspartokinase activity. This finding argues against derepression of either lysine- or threonine-sensitive aspartokinase.

5.1 mM lysine in these plants is an order of magnitude above that required for complete inhibition of lysine-sensitive aspartokinase. Flux through aspartokinase in these plants would therefore be solely dependent on threonine-sensitive activity. Activity of the latter form, at the essentially normal tissue concentration of 0.25 mM threonine in lysine-supplemented plants, was calculated to be 13% of the uninhibited activity; this activity is 0.9% of the *total* uninhibited aspartokinase activity. These data show that only 20% (13 ÷ 65%) of threonine-sensitive aspartokinase activity acting alone, or 1% of the total aspartokinase activity, is adequate for normal flux through the aspartokinase step. This value is in close agreement with the tentative estimate noted above of a 40-fold excess capacity of aspartokinase. Essentially identical results were obtained for plants growing with lysine supplement also containing methionine.

In summary, these data show that a reduction of aspartokinase to less than 1% of its uninhibited value has relatively little effect on flux through the aspartokinase step<sup>6</sup>. Kacser and Porteous (25) use the term 'flux control coefficient' to quantitate the extent to which a particular enzyme in a pathway contributes to the overall regulation of flux. This term is defined as the fractional change in flux relative to a small fractional change in enzyme. High values approaching unity indicate that flux responds almost proportionally to changes in enzyme activity, and define steps that play major roles in regulation. By contrast, enzymes exhibiting low values exercise relatively little control over flux. Although the large changes in aspartokinase in our experiments preclude precise determination, a gross upper limit of 0.3 for the apparent flux control coefficient for aspartokinase was approximated by dividing the decrease in flux (35%) by the corresponding decrease in total aspartokinase activity (99.1%) through aspartokinase in lysine-supplemented plants. This low maximal value for the flux control coefficient indicates that this enzyme exercises little control over flux through the aspartokinase step.

(ii) Growth data fully support the concept that inhibition of aspartokinase is not a major factor in regulation of flux through the aspartokinase step (21). Thus growth of *Lemna* supplemented with lysine under the conditions resulting in greater than 99% inhibition of total aspartokinase activity, does not result in a growth requirement of the other amino acids (methionine or threonine) that are dependent on aspartokinase for their synthesis. Neither does lysine plus methionine result in a requirement for threonine. Similar findings have been reported by Rognes *et al.* (37) in studies with excised barley embryos. Of all possible combinations of lysine, threonine and methionine, only the combination of lysine plus threonine caused appreciable inhibition of growth. This inhibitory effect of lysine plus threonine, and its reversal by methionine, have been reported in a wide range of plant species (8, 10, 29). These effects have been ascribed to a drastic inhibition of flux through the aspartokinase step, resulting from the combined inhibition of both lysine- and threonine-sensitive forms of the enzyme (29). Our studies with *Lemna* are in complete agreement with this proposal. As mentioned in (i) above, the combined presence of lysine plus threonine was the one condition estimated to cause sufficient inhibition of aspartokinase for this enzyme to become limiting for *in vivo* flux

<sup>6</sup> Some physiological effect would be expected from this severe inhibition of aspartokinase. It is suggested (21) that a major end result of feedback inhibition of this enzyme would be to regulate the concentrations of aspartate substrate.

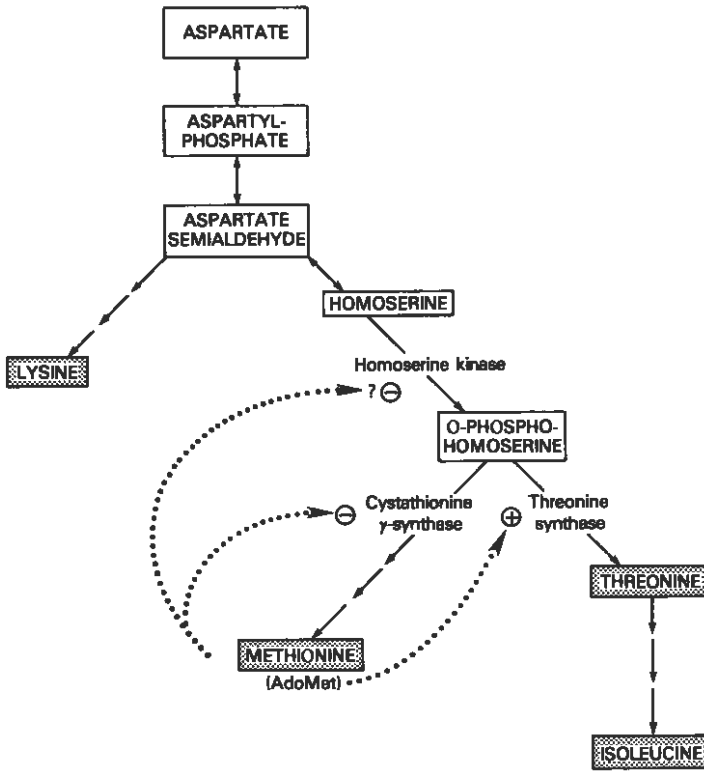

Fig. 5. Revised scheme for regulation of methionine biosynthesis. Proposed regulatory effects are illustrated as described in Fig. 4.

requirements. Direct demonstration of limitation of flux through the aspartokinase step during growth with lysine plus threonine was provided by measurements of flux of 4-carbon units with  $^{14}\text{C}$ -aspartate (21). While growth with threonine alone caused no reduction in flux, and growth with lysine alone caused only a 35% reduction in flux, the combination of threonine plus lysine<sup>7</sup> reduced flux through the aspartokinase step to 4% that of control plants, with comparable reductions into the threonine/isoleucine, methionine, and lysine branches. Regulation of flux through the aspartokinase step under these conditions is probably a laboratory artifact of little physiological significance. The concentrations of lysine and threonine required to limit flux through the aspartokinase step are at least an order of magnitude greater than those found under conditions of normal growth, or under conditions of feedback inhibition of methionine biosynthesis. Further, such stringent inhibition of aspartokinase carries with it the penalty of methionine deprivation.

<sup>7</sup> The additional presence of methionine was required in cultures supplemented with lysine plus threonine in order to obtain normal steady-state growth rates.

### Revised scheme for regulation of methionine biosynthesis

The revised scheme for regulation of methionine biosynthesis illustrated in Fig. 5, although still tentative, is considered to be more accurate than models presented hitherto, and will at least provide a basis for future experimentation. A summary of the main regulatory steps in this scheme follows:

(i) It is firmly established that methionine regulates flux at the cystathionine  $\gamma$ -synthase step. Down regulation of this enzyme observed in methionine-supplemented plants is probably necessary, but was shown not to be sufficient, for regulation of flux into the methionine branch. Inhibition of cystathionine  $\gamma$ -synthase by inorganic phosphate (22) or 3-methylthiopropionate (14) may be additional factors contributing to the reduction of flux through the cystathionine  $\gamma$ -synthase step. The latter compound is a natural product derived from methionine in lower plants (32) and is present as the methyl ester in pineapple (24). However, high concentrations in the order of 0.1 mM were required for inhibition, and it remains to be shown that 3-methylthiopropionate is a natural product of methionine metabolism in higher plants.

(ii) Reduction of flux into the methionine branch must be accompanied by an equivalent reduction of flux into O-phosphohomoserine. If flux into O-phosphohomoserine were not reduced during regulation of methionine biosynthesis, the resultant increased concentration of O-phosphohomoserine would be expected to increase flux through cystathionine  $\gamma$ -synthase (thereby restoring flux through this step), and/or to divert 4-carbon units normally entering the methionine branch into the threonine/isoleucine branch (resulting in an accumulation of soluble threonine). Neither effect was observed.

(iii) It is speculated that homoserine kinase, which catalyzes the first irreversible step in the series of reactions leading to methionine, is the most likely site at which regulation of O-phosphohomoserine synthesis might occur during regulation of methionine biosynthesis. Limited studies of this enzyme reveal properties which could potentially allow a reduction in flux at the homoserine kinase step by just the amount needed for regulation of methionine biosynthesis, without affecting flux into the threonine/isoleucine branch. For example, AdoMet-sensitive and AdoMet-insensitive homoserine kinases have been reported in pea leaves (30), and Baum *et al.* (2) have described homoserine kinase activity in radish leaves that is allosterically inhibited by AdoMet and isoleucine.

(iv) Although the physiological significance of the allosteric stimulation of threonine synthase by AdoMet remains to be clarified, there is no evidence to suggest that this effect is not important *in vivo* and it is therefore included in the revised scheme. The *in vivo* role of this stimulation becomes especially intriguing in the light of our findings that the pool of soluble threonine is not elevated in methionine-supplemented plants, and that the steps catalyzed by aspartate kinase and homoserine dehydrogenase are not major sites for regulation of flux. It is suggested that the stimulation by AdoMet of threonine synthase may help maintain normal rates of synthesis of threonine in the face of lowered concentrations of O-phosphohomoserine.

### Implications of revised scheme

To the extent that *Lemna* is representative of higher plants, the ideas outlined in Fig. 5 provide valuable guidance in attempts to enhance the nutritional value of crop

plants by increasing their contents of methionine, lysine and threonine. Two major points are brought clearly into focus. First, if other factors are unchanged, even if an increased rate of synthesis of aspartyl phosphate were achieved, the available product is unlikely to be favorably distributed from a nutritional point of view. Methionine (17), lysine (21) and isoleucine (19, 21) each strongly feedback regulates its own synthesis, whereas threonine does not (19, 21). Any increased synthesis of the aspartate family of amino acids might therefore be expected to result in increased synthesis of threonine, but not of the other amino acids. A second problem follows from the low flux control coefficient of aspartokinase: increased activities of aspartokinase or decreased sensitivities to inhibition by lysine or threonine would not be expected to be accompanied by corresponding increases in flux through aspartokinase. This property of aspartokinase argues against the strategy of selecting for plant variants resistant to growth with lysine plus threonine, and containing aspartokinase with higher activity or diminished sensitivity to inhibition by lysine or threonine (6). Since the concentration of aspartate, rather than the activity of aspartokinase, probably limits flux through the aspartokinase step (21), it is suggested that efforts would best be directed toward increasing the steady-state supply of aspartate to the site of aspartokinase in chloroplasts. Some speculations on how this may be accomplished, while at the same time achieving a desirable nutritional balance in the increased synthesis of the aspartate family of amino acids are discussed in detail elsewhere (21).

### Acknowledgement

My sincere appreciation is expressed to Drs. S.H. Mudd and A.H. Datko for their long-term collaboration in studies of the regulation of methionine biosynthesis, and for their helpful comments and suggestions on the manuscript. I am indebted to Mrs. Kathy Carter for expert processing of the manuscript.

### Literature cited

1. Allaway, W.H. and Thompson, J.F. 1966. Sulfur in the nutrition of plants and animals. *Soil Sci.* 101: 240-247.
2. Baum, H.J., Madison, J.T. and Thompson, J.F. 1983. Feedback inhibition of homoserine kinase from radish leaves. *Phytochem.* 22: 2409-2412.
3. Bergmann, L., Schwenn, J.D. and Urlaub, H. 1980. A denosinetriphosphate sulfurylase and O-acetylserine sulfhydrylase in photoheterotrophically and heterotrophically cultured tobacco cells. *Z. Naturforsch.* 35c: 952-957.
4. Black, S. and Wright, N.G. 1955.  $\beta$ -Aspartokinase and  $\beta$ -aspartyl phosphate. *J. Biol. Chem.* 213: 27-38.
5. Black, S. and Wright, N.G. 1955. Aspartic  $\beta$ -semialdehyde dehydrogenase and aspartic  $\beta$ -semialdehyde. *J. Biol. Chem.* 213: 39-50.
6. Bright, S.W.J., Wallsgrave, R.M. and Mifflin, B.J. 1985. Biochemical genetics of the aspartate-derived amino acids in plants. In: *Plant genetics*, Freeling, M. ed., pp. 701-713. Alan R. Liss, New York.
7. Brunold, C. and Suter, M. 1982. Intracellular localization of serine acetyltransferase in spinach leaves. *Planta* 155: 321-327.
8. Bryan, J.K. 1980. Synthesis of aspartate family and branched-chain amino acids. In: *The biochemis-*

- try of plants, vol. 5, Mifflin, B.J. ed., pp. 403-452. Academic Press, New York
9. Bryan, J.K. and Eberle, J.B. 1988. Amino acid biosynthesis: mechanisms and regulation. 14th International congress of biochemistry, Prague, Czechoslovakia, pp. 25-26.
  10. Datko, A.H. and Mudd, S.H. 1982. Methionine biosynthesis in *Lemna*: Inhibitor studies. *Plant Physiol.* 69: 1070-1076.
  11. Datko, A.H. and Mudd, S.H. 1984. Responses of sulfur-containing compounds in *Lemna paucicostata* Hegelm. 6746 to changes in availability of sulfur sources. *Plant Physiol.* 75: 474-479.
  12. Datko, A.H. and Mudd, S.H. 1985. Uptake of amino acids and other organic compounds by *Lemna paucicostata* Hegelm. 6746. *Plant Physiol.* 77: 770-778.
  13. Datko, A.H., Mudd, S.H. and Giovanelli, J. 1980. *Lemna paucicostata* Hegelm. 6746: Development of standardized growth conditions suitable for biochemical experimentation. *Plant Physiol.* 65: 906-912.
  14. DeBry, L. 1986. Methionine in plant molecular breeding. Dissertation, Rothamsted Experimental Station, England, and University of Brussels, Belgium.
  15. Giovanelli, J. 1987. Sulfur amino acids of plants: an overview. In: *Methods in enzym.* vol. 143, Jacoby, W.B. and Griffith, O.W. eds., pp. 419-426, Academic Press, New York.
  16. Giovanelli, J., Mudd, S.H. and Datko, A.H. 1980. Sulfur amino acids in plants. In: *The biochemistry of plants*, vol. 5, Mifflin, B.J. ed., pp. 453-505, Academic Press, New York.
  17. Giovanelli, J., Mudd, S.H. and Datko, A.H. 1985. *In vivo* regulation of *de novo* methionine biosynthesis in a higher plant (*Lemna*). *Plant Physiol.* 77: 450-455.
  18. Giovanelli, J., Mudd, S.H. and Datko, A.H. 1985. Quantitative analysis of pathways of methionine metabolism and their regulation in *Lemna*. *Plant Physiol.* 78: 555-560.
  19. Giovanelli, J., Mudd, S.H. and Datko, A.H. 1988. *In vivo* regulation of threonine and isoleucine biosynthesis in *Lemna paucicostata* Hegelm. 6746. *Plant Physiol.* 86: 369-377.
  20. Giovanelli, J., Mudd, S.H. and Datko, A.H. 1989. Aspartokinase of *Lemna paucicostata* Hegelm. 6746. *Plant Physiol.* 90: 1577-1583.
  21. Giovanelli, J., Mudd, S.H. and Datko, A.H. 1989. Regulatory structure of the biosynthetic pathway for the aspartate family of amino acids in *Lemna paucicostata* Hegelm. 6746, with special reference to the role of aspartokinase. *Plant Physiol.* 90: 1584-1599.
  22. Giovanelli, J., Mudd, S.H., Datko, A.H. and Thompson, G.A. 1986. Effects of orthophosphate and adenosine 5'-phosphate on threonine synthase and cystathionine  $\gamma$ -synthase of *Lemna paucicostata* Hegelm. 6746. *Plant Physiol.* 81: 577-583.
  23. Giovanelli, J., Veluthambi, K., Thompson, G.A., Mudd, S.H. and Datko, A.H. 1984. Threonine synthase of *Lemna paucicostata* Hegelm. 6746. *Plant Physiol.* 76: 285-292.
  24. Haagen-Smit, A.J., Kirchner, J.G., Deasy, C.L. and Prater, A.N. 1945. Chemical studies of pineapple (*Ananas sativus* Lindl). II. Isolation and identification of a sulfur-containing ester in pineapple. *J. Amer. Chem. Soc.* 67: 1651-1652.
  25. Kacser, H. and Porteous, J.W. 1987. Control of metabolism: What do we have to measure? *TIBS* 12: 5-15.
  26. Kirchner, S.C. and Bryan, J.K. 1985. Isolation and characterization of two forms of maize threonine dehydratase. *Plant Physiol.* 77: S-109.
  27. Kumpaisal, R., Hashimoto, T. and Yamada, Y. 1987. Purification and characterization of dihydrodipicolinate synthase from wheat suspension cultures. *Plant Physiol.* 85: 145-151.
  28. Madison, J.T. and Thompson, J.F. 1976. Threonine synthase from higher plants: stimulation by S-adenosylmethionine and inhibition by cysteine. *Biochem. Biophys. Res. Commun.* 71: 684-691.
  29. Mifflin, B.J. and Lea, P.J. 1982. Ammonia assimilation and amino acid metabolism. In: *Nucleic acids and proteins in plants*. I. Boulter, D. and Parthier, B. eds., pp. 5-64, Springer Verlag, Berlin.
  30. Muhitch, M.J. and Wilson, K.G., 1983. Chloroplasts are the subcellular location of both soluble and membrane-associated homoserine kinases in pea (*Pisum sativum* L.) leaves. *Z. Pflanzenphysiol.* 110: 39-46.
  31. Newsholme, E.A. and Crabtree, B. 1979. Theoretical principles in the approaches to control of metabolic pathways and their application to glycolysis in muscle. *J. Mol. Cell Cardiol.* 11: 839-856.
  32. Pokorny, M., Marcenko, E. and Keglavic, D. 1970. Comparative studies of L- and D-methionine metabolism in lower and higher plants. *Phytochem.* 9: 2175-2188.
  33. Rennenberg, H. 1984. The fate of excess sulfur in higher plants. *Annu. Rev. Plant Physiol.* 35: 121-153.
  34. Reuveny, Z. and Filner, P. 1977. Regulation of adenosine triphosphate sulfurylase in cultured tobacco



- cells. Effects of sulfur and nitrogen sources on the formation and decay of the enzyme. *J. Biol. Chem.* 252: 1858-1864.
35. Rognes, S.E., Bright, S.W.J. and Mifflin, B.J. 1983. Feedback-insensitive aspartate kinase isoenzymes in barley mutants resistant to lysine plus threonine. *Planta* 157: 32-38.
  36. Rognes, S.E., Lea, P.J. and Mifflin, B.J. 1980. *S*-adenosylmethionine – a novel regulator of aspartate kinase. *Nature* 287: 357-359.
  37. Rognes, S.E., Wallsgrave, R.M., Kueh, J.S.H. and Bright, S.W.J. 1986. Effects of exogenous amino acids on growth and activity of four aspartate pathway enzymes in barley. *Plant Sci.* 43: 45-50.
  38. Rosenthal, G.A. 1982. Plant nonprotein amino and imino acids, Academic Press, N.Y.
  39. Saidha, T. and Schiff, J.A. 1987. Pathways of assimilatory sulfate reduction in plants and microorganisms. In: *Models in plant physiology and biochemistry*, vol. 2, Newman, D.W. and Wilson, K.G. eds., pp. 37-41, CRC Press, Boca Raton, Florida.
  40. Smith, I.K. 1972. Studies of L-cysteine biosynthetic enzymes in *Phaseolus vulgaris* L. *Plant Physiol.* 50: 477-479.
  41. Smith, I.K. 1980. Regulation of sulfate assimilation in tobacco cells. Effect of nitrogen and sulfur nutrition on sulfate permease and O-acetylserine sulfhydrylase. *Plant Physiol.* 66: 877-883.
  42. Smith, I.K., Thompson, J.F. 1971. Purification and characterization of L-serine transacetylase and O-acetyl-L-serine sulfhydrylase from kidney bean seedlings (*Phaseolus vulgaris*). *Biochim. Biophys. Acta* 227: 288-295.
  43. Thompson, G.A., Datko, A.H. and Mudd, S.H. 1982. Methionine synthesis in *Lemna*: inhibition of cystathionine  $\gamma$ -synthase by propargylglycine. *Plant Physiol.* 70: 1347-1352.
  44. Thompson, G.A., Datko, A.H., Mudd, S.H. and Giovanelli, J. 1982. Methionine biosynthesis in *Lemna*. Studies on the regulation of cystathionine  $\gamma$ -synthase, O-phosphohomoserine sulfhydrylase, and O-acetylserine sulfhydrylase. *Plant Physiol.* 69: 1077-1083.
  45. Umbarger, H.E. 1978. Amino acid biosynthesis and its regulation. *Annu. Rev. Biochem.* 47: 533-606.

## DISCUSSION SECTION 1

### Regulation of uptake and reduction of sulfate and of cysteine formation

#### *Uptake*

Experiments using isolated roots from tobacco show an inhibition of  $^{35}\text{SO}_4^{2-}$  uptake by glutathione. Since it has been shown that glutathione is transported from shoots to roots, it could be a signal compound for controlling  $\text{SO}_4^{2-}$  uptake. These results do not seem to exclude internal sulfate concentration as a signal, however, because glutathione can be oxidized to sulfate rather rapidly. Even though no increase in sulfate concentration was detected in the presence of glutathione, a small, but relevant increase in the cytoplasm may have escaped detection. In green algae, which do not oxidize glutathione, it was shown that sulfate uptake was regulated by the internal sulfate pool. Since oxidized glutathione inhibits protein synthesis the result from excised roots could also be explained by assuming that  $\text{SO}_4^{2-}$  is no longer reduced because of this inhibition. It thus accumulates and inhibits uptake of  $^{35}\text{SO}_4^{2-}$ .

#### *Regulation of reduction*

ATP sulfurylase, the first enzyme of assimilatory sulfate reduction is regulated in various different ways. This could be anticipated from its strategic position in the pathway. Inhibition by its product adenosine 5'-phosphosulfate and by adenosine 5'-monophosphate and derepression by an appropriate nitrogen source have been known before. In maize, the extractable activity of the enzyme is increased under conditions of sulfur starvation and at high light intensities and decreased by cysteine and sulfate. Experiments using isolated maize chloroplasts indicate a light activation of ATP sulfurylase, but this does not seem to be an ubiquitous regulatory mechanism.

The whole pathway of assimilatory sulfate assimilation seems also to be regulated by the sulfate concentrations present in the plants, since increased levels of thiols were detected in the presence of high sulfate concentrations.

An increase in thiols was also detected at lower temperatures; it is not clear, however, whether this results from increased sulfate reduction or inhibition of protein synthesis with a parallel inhibition of assimilatory sulfate reduction.

In view of the different pathways proposed for the reduction of sulfate in higher plants the question of mutants for sorting out the physiological relevant pathways was addressed. A great number of useful mutants have been described in the nitrate reduction pathway. In view of the many similarities between sulfate and nitrate reduction the isolation of mutants should not be impossible. In bacteria, mutants for every enzyme of the pathway have been detected, and in *Chlorella*, several mutants have also been described. Up to the present moment, however, no mutant in the pathway of assimilatory sulfate reduction of higher plants has been described. It seems, however, that mutants from plants should be feasible, using thiosulfate as a screening substance.

Roots contain all enzymes of assimilatory sulfate reduction and they can be isolated and cultivated in nutrient solution containing sulfate as sole sulfur source. This shows that they are completely autonomous with respect to sulfate assimilation. It is not clear, however, if in the intact plant, the roots are also selfsufficient, because it has been shown that glutathione is transported from the leaves to the roots and its sulfur is incorporated into root proteins. Much more work will be necessary for a final conclusion, which may then be close to that from experiments in the field of nitrate assimilation, where the distribution of the *in vivo* reduction between shoot and root is different from species to species.

The level of cysteine, which seems to be toxic to plants at increased concentrations, is regulated via the enzymes of assimilatory sulfate reduction, the availability of O-acetyl-L-serine, the release of sulfide from the carrier, the utilization, mainly for the synthesis of proteins, methionine and glutathione and degradation. Serine transacetylase, which catalyzes the formation of O-acetyl-L-serine, is inhibited by very low concentrations of cysteine in bacteria. In higher plants this enzyme activity is not modulated in its extractable activity by cysteine. Under anaerobic conditions, rather low concentrations of cysteine inhibit the enzyme *in vitro*. This regulation may also be of importance *in vivo* for coordinating assimilatory sulfate and nitrate reduction with the aim to synthesize appropriate amounts of amino acids and sulfur amino acids for protein synthesis.

## **Section 2.**

### **Metabolism of sulfur into organic sulfur compounds**

## Contents

2.1	H. Rennenberg and G.L. Lamoureux, Physiological processes that modulate the concentration of glutathione in plant cells	53
2.2	M. Kreis, Synthesis, structure and evolutionary relationships of sulfur-rich seed proteins in higher plants	67
2.3	K.F. Kleppinger-Sparace, S.A. Sparace and J.B. Mudd, Plant sulfolipids	77
2.4	E. Grill, E.-L. Winnacker and M.H. Zenk, Phytochelatins, the heavy metal binding peptides of the plant kingdom	89
2.5	E. Schnug, Glucosinolates fundamental, environmental and agricultural aspects	97
2.6	Discussion	107

# PHYSIOLOGICAL PROCESSES THAT MODULATE THE CONCENTRATION OF GLUTATHIONE IN PLANT CELLS

Heinz Rennenberg<sup>1</sup> and Gerald L. Lamoureux<sup>2</sup>

<sup>1</sup>*Fraunhofer-Institut für Atmosphärische Umweltforschung, D-8100 Garmisch-Partenkirchen, F.R.G.*; <sup>2</sup>*USDA, Agricultural Research Service, Biosciences Research Laboratory, Fargo, ND 58105, U.S.A.*

## Contents

Introduction	53
Distribution of glutathione in plant cells	53
Synthesis of glutathione	55
Glutathione degradation	56
Membrane- and long-distance transport of glutathione	58
Conjugation of glutathione with xenobiotics	60
Conclusions	62
Literature cited	62

## Introduction

Glutathione ( $\gamma$ -glutamylcysteinylglycine) is the most abundant low molecular weight thiol in most animal and plant cells (30, 42). High concentrations of thiols have also been detected in procaryotic organisms, however, a significant number of these organisms, especially the anaerobic bacteria, contain very low concentrations of glutathione (19). Coenzyme A and  $\gamma$ -glutamylcysteine are the major low-molecular weight thiols in some of these organisms (46, 66). Glutathione was not detected in the eukaryote, *Entamoeba histolytica*, but high concentrations of cysteine and several unidentified thiols were present (22). Mutants of *E. coli* that lack glutathione and the enzymes for glutathione biosynthesis grow at the same rate as the parental strains, but they are highly susceptible to a wide range of chemical agents (2). Based on these observations, it can be concluded that glutathione is not a primary product of cellular metabolism essential for life, but it may play an important role in the detoxification of compounds that are unfavorable for growth.

## Distribution of glutathione in plant cells

Glutathione is not the major low molecular weight thiol in all higher plants. As first reported by Price (49), several legumes contain a structural analog of glutathione. This analog, initially named phaseothione, was identified as  $\gamma$ -glutamylcysteinyl- $\beta$ -

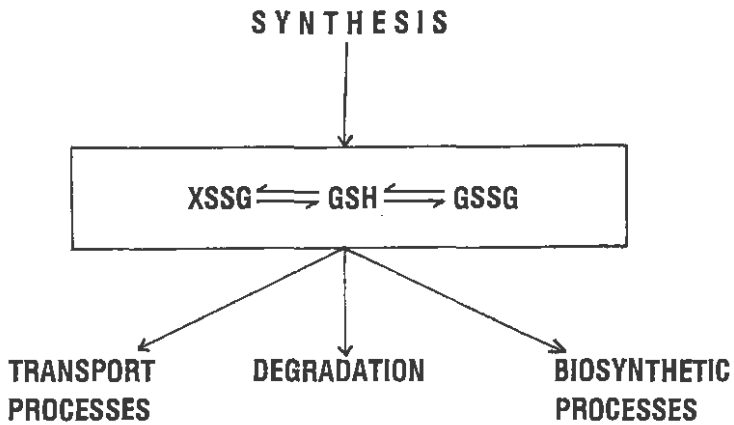

Fig. 1. Processes that modulate the concentration of glutathione. XSSG, glutathione mixed disulfides; GSH, reduced glutathione; GSSG, oxidized glutathione.

alanine (homogluthathione) (8, 9). Recent experiments have shown that homogluthathione is present in addition to glutathione in many legumes and that the ratio of glutathione/homogluthathione may vary by orders of magnitude between different tribes and also between different organs of the same species (31). These differences within the same species may be explained by differences in glutathione/homogluthathione metabolism between organs and/or selective transport. Therefore, it is uncertain to what extent homogluthathione is not only a structural analog of glutathione, but also a functional analog. A survey of the thiol composition of other orders of the Plant Kingdom has not been performed, so it is not known whether the presence of structural analogs of glutathione is restricted to legumes.

Large variations in glutathione levels in different plant organs have been observed (*e.g.* 31). These variations may be due to differences in the role of glutathione in the various plant organs. Glutathione is present in higher concentrations in the leaves than in the roots (31). In the leaves, glutathione appears to be involved in the detoxification of injurious oxygen species generated in the chloroplasts (27). In the roots, glutathione levels can be elevated by exposure to certain xenobiotics (*e.g.* 38). In plants, seeds contain the highest concentrations of glutathione (*e.g.* 31). In most living cells glutathione is largely maintained in its reduced form (GSH) by glutathione reductase, but seeds and spores may contain high concentrations of glutathione disulfide (GSSG) and glutathione mixed disulfides (18, 20, 21). It is likely that GSSG contributes to dormancy in seeds and spores by inhibition of protein synthesis (21, 35). GSSG-mediated inhibition of protein synthesis is also observed in plants exposed to drought-stress (13).

The distribution of glutathione within plant cells has been investigated by several authors. From 50-76% of the glutathione was found in the chloroplasts and the concentration of glutathione in this organelle is in the millimolar range (23, 32, 51, 69, 75). Based on studies with fractionated protoplasts, it was estimated that 7% of the glutathione is in the cytoplasm and 17% in the vacuole (*cf.* 51); however, unequivocal proof that glutathione is a constituent of the vacuole is lacking.

The concentration of glutathione within a plant cell is not constant, but is modu-

lated by developmental and environmental factors. The glutathione content of spruce needles varies with the season. High concentrations are observed in the winter and spring and low concentrations during the summer (17). In several species, the concentration of glutathione undergoes light-dependent changes (5, 7, 68) that result in diurnal fluctuations (34, 64). Many environmental factors, *e.g.*, the sulfur content of the soil and the atmosphere (11, 12, 24), growth at high altitudes (25), temperature (47), etc. are known to affect the concentration of glutathione in plant cells. However, the target or the trigger that mediates changes in glutathione concentrations has not been elucidated. Obviously, glutathione levels can be modulated by synthesis and degradation in response to environmental factors; however, long-distance transport, membrane transport, and biosynthetic processes can also contribute to changes in cellular glutathione contents (Fig. 1).

### Synthesis of glutathione

Synthesis of glutathione has been intensively studied in animal and bacterial cells (44). These studies have shown that glutathione is not translated directly from mRNA, but is synthesized enzymatically in two steps. In the first step,  $\gamma$ -glutamylcysteine is produced from glutamate and cysteine in an ATP-dependent reaction catalyzed by  $\gamma$ -glutamylcysteine synthetase ( $\gamma$ -GCS; EC 6.3.2.2). In the second step, catalyzed by glutathione synthetase (GSH-S; EC 6.3.2.3), glycine is added to  $\gamma$ -glutamyl-



cysteine at the C-terminal site to yield glutathione. Both enzymes of glutathione biosynthesis have been purified from animal sources to apparent homogeneity and their catalytic and physical properties have been characterized (43, 63).

In higher plants, glutathione appears to be synthesized by the same two-step mechanism. The intermediate of glutathione biosynthesis,  $\gamma$ -glutamylcysteine, is present in many plant species (30). During illumination of spinach leaves, this dipeptide declined to about the same extent as the concentration of glutathione increased (7). In crude homogenates of maize roots or cultured tobacco cells, glutathione is synthesized from its constituent amino acids in the presence of ATP (10, 53). A preliminary report by Steffens and Williams (70) indicated the presence of  $\gamma$ -GCS in cultured tomato cells; however, the first comprehensive study of plant  $\gamma$ -GCS (cultured tobacco cells) is reported in this book by Bergmann and Hell (3). As observed for mammalian  $\gamma$ -GCS, tobacco  $\gamma$ -GCS can also utilize  $\alpha$ -amino-butyrate instead of cysteine as a substrate; however, the affinity of tobacco  $\gamma$ -GCS for  $\alpha$ -amino-butyrate is much lower than that found for  $\gamma$ -GCS from mammalian sources (65). Tobacco  $\gamma$ -GCS is inhibited by methionine-S-sulfoximine and buthionine sulfoximine, indicative of an enzyme-bound  $\gamma$ -glutamyl phosphate intermediate (cf. 44). Tobacco  $\gamma$ -GCS has a



molecular weight of 60 kDa (gel chromatography), and it undergoes dissociation into two equal 34 kDa subunits upon treatment with dithioerythritol. Dissociation is accompanied by a large loss in activity. Animal  $\gamma$ -GCS dissociates into a heavy and a light subunit, and the heavy subunit exhibits full enzymatic activity (cf. 44). Glutathione is an inhibitor of tobacco  $\gamma$ -GCS. Inhibition is competitive with respect to glutamate and the apparent  $K_i$  for GSH of 0.4-0.6 mM may suggest a physiologically significant feedback mechanism.

Glutathione synthetases from several plant species have been characterized (29, 32, 33, 39, 40). The GSH-Ss from legumes have an apparent molecular weight of 84 kDa (40). Inhibition of GSH-S from spinach by thiol reagents suggests the presence of a thiol in the catalytic site of the enzyme (39). The GSH-Ss from pea and tobacco have similar affinities to  $\gamma$ -glutamylcysteine and  $\gamma$ -glutamyl- $\alpha$ -amino-butyrate (29, 40); however, significant differences were observed in the specificity of GSH-Ss from different plant sources for the amino acid added to  $\gamma$ -glutamylcysteine. Plants that contain high levels of homoglutathione contain GSH-Ss with a greater affinity to  $\beta$ -alanine than glycine, and plants that contain high levels of glutathione contain GSH-Ss with a greater affinity for glycine than  $\beta$ -alanine (33, 40). This observation led to the denomination of 'homo-GSH-synthetase' for the enzyme present in plants that contain high levels of homoglutathione (40). Both homo-GSH-S and GSH-S are strongly inhibited by 5 mM ADP, but they are only slightly affected by 5mM GSH (39, 40). GSH-S seems to be present in both the chloroplasts and the cytoplasm (29, 32) and it appears that glutathione synthesis may take place in both cellular compartments. The rate of glutathione synthesis and the factors which control this rate have not been elucidated.

### Glutathione degradation

Glutathione degradation is an essential part of sulfur nutrition in higher plants. Tobacco suspension cultures are able to grow with glutathione as the sole source of sulfur (56). The roots and the growing parts of the stem of several plant species are supplied with reduced sulfur in the form of glutathione via long-distance transport (see below). Significant amounts of glutathione must be degraded in these tissues to make the reduced sulfur available for protein synthesis. The rate of glutathione turnover and the factors that modulate this process have not been investigated in plant cells.

In animal cells, the degradation of glutathione is initiated by a  $\gamma$ -glutamyl transpeptidase ( $\gamma$ -GT; EC 2.3.2.2). This enzyme catalyzes the transfer of the  $\gamma$ -glutamyl moiety of glutathione to an amino acid acceptor (AA) (44). The resultant dipeptide,



cysteinylglycine, is hydrolyzed by a dipeptidase (EC 3.4.13.6). The  $\gamma$ -glutamyl dipeptide produced in the  $\gamma$ -GT reaction is cyclized by a  $\gamma$ -glutamyl cyclotransferase



( $\gamma$ -GCT; EC 2.3.2.4) to 5-oxo-proline, the cyclic lactam of glutamic acid. The 5-oxo-proline is then hydrolyzed to glutamic acid by an ATP-dependent reaction catalyzed

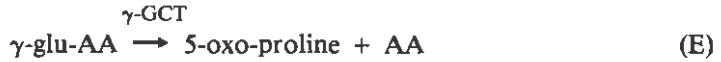

catalyzed by 5-oxo-prolinase (5-OP). This reaction appears to be the rate-limiting step of glutathione degradation in animals (44). From this pathway of glutathione

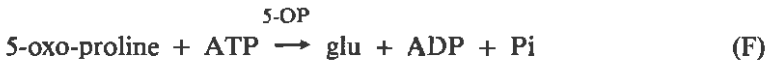

degradation and the pathway of glutathione synthesis outlined above, Meister and coworkers suggested the  $\gamma$ -glutamyl-cycle and proposed that transport of amino acids by a membrane bound  $\gamma$ -GT is a function of this cycle (44). Although the proposed function of the  $\gamma$ -glutamyl-cycle is controversial (cf. 51), the series of reactions involved in the degradation of glutathione in animals has been definitely established.

The path of glutathione degradation in plants is less certain, but several observations support the hypothesis that glutathione degradation proceeds by a different pathway in plants than in animals. Experiments with radiolabeled glutathione have shown that  $\gamma$ -glutamylcysteine and 5-oxo-proline are intermediates in glutathione degradation in plant cells (59, 71), but pulse-labeling experiments to establish the sequence of these reactions have not been performed. Cysteinylglycine, an intermediate of glutathione degradation in animal cells, has not been observed in plant cells.  $\gamma$ -Glutamylcysteine derivatives have been found as metabolites of glutathione conjugates of pesticides in plants, but cysteinylglycine derivatives have been consistently found as intermediates of glutathione conjugate metabolism in animals (38). From these findings, a pathway for glutathione degradation in plants has been suggested (51). Glutathione degradation is initiated by the removal of the glycine moiety by the action of a carboxypeptidase (CP). The  $\gamma$ -glutamylcysteine produced by this reaction can be used for glutathione synthesis (reaction B), or it can be further degraded to

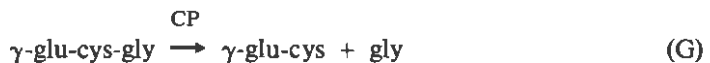

cysteine and glutamate by the action of  $\gamma$ -GCT and 5-OP (reactions E, F and Fig. 2). This pathway requires the action of a  $\gamma$ -GCT highly specific for  $\gamma$ -glutamylcysteine since plant cells frequently contain significant concentrations of other  $\gamma$ -glutamyl dipeptides. Although the  $\gamma$ -GCTs from animals appear to be relatively non-specific, the  $\gamma$ -GCT from tobacco is highly specific for S-containing  $\gamma$ -glutamyl dipeptides (72). 5-Oxo-prolinase, also required for this pathway, has been

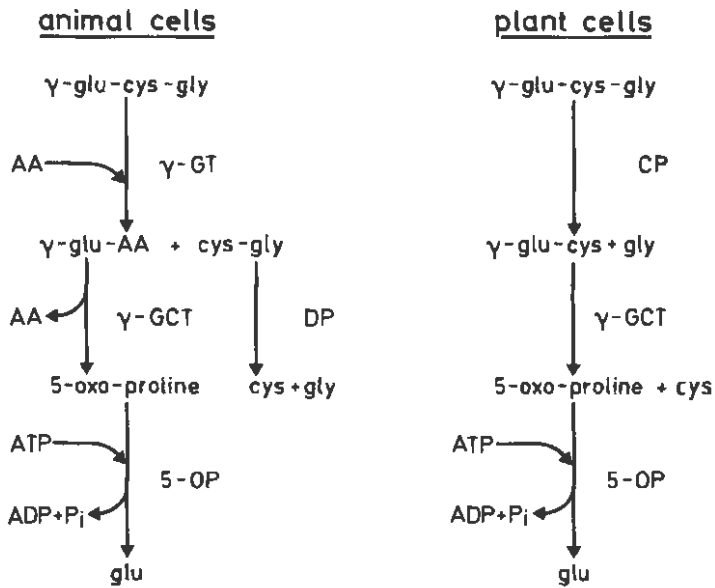

Fig. 2. Pathways of glutathione degradation.

observed in numerous plant species (cf. 51). This enzyme is regulated by sulfur nutrition, a prerequisite if it plays a role as the rate-limiting factor in glutathione degradation (55). A glutathione-specific carboxypeptidase, which would also be anticipated, has not been demonstrated in plant cells. Both  $\gamma$ -GCT and 5-OP are soluble enzymes localized in the cytoplasm (58, 72); therefore, glutathione degradation in plants probably occurs in this cellular compartment.

### Membrane- and long-distance transport of glutathione

Export of glutathione has been observed in bacterial (48), animal (cf. 44), and plant cells (cf. 51). In green tobacco suspension cultures, up to 99% of the glutathione synthesized by the cells is translocated into the culture medium (4, 52). Considerable export of glutathione from the leaf mesophyll cells must occur since glutathione is the predominant form of reduced sulfur translocated in the phloem from the leaves to the roots (6, 57). Glutathione is transported in the reduced form in all plant species that have been investigated (6, 44, 48), but GSSG can be exported in some animal tissues if the intracellular GSSG level is sufficiently elevated (cf. 44).

Little if any intact glutathione is taken up by animal tissue (cf. 44). Extracellular glutathione is degraded by membrane-bound  $\gamma$ -GT and the resultant  $\gamma$ -glutamyl dipeptides and amino acids are taken up by the cells. Several observations indicate an influx of glutathione-sulfur into plant cells. Glutathione accumulated in the medium of photoheterotrophic tobacco suspension cultures grown with sulfate as the source of sulfur; after the sulfate had been depleted, the cells were able to take up glutathione and grow with it as the source of sulfur (4, 52, 56). Glutathione transported in the phloem to the roots (57) has to be taken up by the root tissue to make the

reduced sulfur available for protein synthesis. Experiments with tobacco cells have shown that extracellular glutathione is transported intact (50). Glutathione is taken up by plant cells exclusively in its reduced form (Rennenberg, unpublished results). Apparently the influx of extracellular glutathione proceeds via different processes in animal and plant cells.

Recent experiments have shown that the uptake of glutathione by tobacco cells is an active, carrier-mediated process (Rennenberg, unpublished results). At physiological concentrations ( $10^{-3}$  –  $10^{-5}$  M), glutathione transport exhibited biphasic kinetics with apparent  $K_m$ -values of  $1.4 \cdot 10^{-5}$  M and  $7.8 \cdot 10^{-4}$  M, respectively. This biphasic kinetics may be the consequence of different catalytic properties of glutathione transport systems at the plasmalemma and tonoplast membrane. The hypothesis that transport of glutathione in plant cells can occur at the tonoplast membrane is consistent with the transient elevation of glutathione levels in response to elevated levels of sulfur in the atmosphere or soil (11, 12, 24); however, direct evidence for a transport of glutathione into the vacuole is lacking.

In higher plants, glutathione can not only undergo membrane transport, but it can also undergo long-distance transport in the phloem (6, 41, 57, 60). Transport of glutathione in the phloem is observed irrespective of whether plant roots are supplied with sulfate or the leaves are supplied with sulfate, sulfite, or sulfur dioxide (cf. 60). Glutathione appears to be transported in the phloem in its reduced form (6) and may be maintained in that state by glutathione reductase activity present in the transport tissue (1). Neither retranslocation of significant amounts of glutathione in the xylem nor glutathione accumulation in the roots and growing parts of the stem were observed when plants were grown with sufficient but not excess amounts of sulfur. Therefore, it can be assumed that during vegetative growth, long-distance transport of glutathione to the roots and the growing parts of the stems is required to supply these organs with sufficient reduced sulfur for protein synthesis that takes place mainly in the mature leaves (60). Homoglutathione is the major form of reduced sulfur in the transport tissue and the developing fruit of the legume, *Vigna radiata* (41). Therefore, translocation of glutathione may also be necessary for the storage of reduced sulfur in the seeds. The rate of long-distance transport of glutathione has not been determined in any plant species, but Alosi et al. (1) reported millimolar concentrations of glutathione in the phloem exudate of cucurbits, suggesting that high concentrations of glutathione are translocated in the phloem of these plants.

Recent experiments suggest an additional function for the long-distance transport of glutathione. Sulfate transport is inhibited by physiological glutathione concentrations in heterotrophic, but not in green tobacco cells (56); apparently glutathione or one of its metabolic products inhibits *de novo* synthesis of sulfate carriers in heterotrophic cells (54). Experiments with root segments of tobacco indicate that glutathione may inhibit the uptake of sulfate in the intact plant (Herschbach and Rennenberg, unpublished results). Therefore, the sulfur nutrition of the plant may be regulated by the synthesis and transport of glutathione. Sulfate available to the roots may be initially taken up in amounts that exceed the plant's requirement for sulfur. Uptake of excess sulfate by the roots would result in transport of excess sulfate in the xylem to the leaves. As a consequence, sulfate would accumulate in the leaves and sulfate reduction and assimilation would be enhanced. Under these conditions, glutathione would accumulate in the leaves (11), but it could also be translo-

cated to the roots. If translocation of glutathione from the leaves to the roots exceeds the needs of the roots for reduced sulfur, glutathione or one of its metabolic products would accumulate in the roots. Accumulation of such products could inhibit further sulfate uptake by preventing *de novo* synthesis of sulfate carrier entities. Additional experiments are needed to test this hypothesis.

### Conjugation of glutathione with xenobiotics

The concentration of glutathione in plant cells is not only the result of synthesis and degradation, but it is also the result of metabolic processes that utilize glutathione as a substrate. These metabolic processes include phytochelatin synthesis (26, 61), synthesis of glutathionyl-polyamines (73) and conjugation of glutathione with xenobiotics (38). Because of the current interest in the metabolic fate and the selectivity of pesticides in plants, conjugation of glutathione with pesticides is probably the best understood example among the metabolic processes that utilize glutathione as a substrate. Although spontaneous conjugation with glutathione has been observed *in vitro*, in the living cell this reaction is usually catalyzed by a group of enzymes, the glutathione-S-transferases (GSTs; EC 2.5.1.18). The toxic effects of many pesticides in plants can be diminished or prevented by the action of these enzymes. The large amount of data published on this subject has been reviewed recently (38) and only a few important findings are excerpted in this discussion.

Enzymatic glutathione conjugation of pesticides can proceed via different types of reactions, including the following: nucleophilic displacement of a chloro- and/or a nitro-group as observed with the triazine herbicides, such as atrazine, with the chloroacetamide herbicides, such as metolachlor, or with the fungicide, pentachloronitrobenzene; nucleophilic diphenyl ether cleavage as observed with the herbicides, fluorodifen and acifluorfen; nucleophilic addition to an epoxide ring as observed with the herbicide synergist, tridiphane; or glutathione conjugation following an activation reaction as observed with the thioacetamide herbicide EPTC (36,38). EPTC is oxidized to a sulfoxide prior to conjugation with glutathione (38). Plant GST enzymes also exhibit glutathione peroxidase activity *in vitro*, but it has not been established whether this is a normal physiological role for GSTs (14).

From the broad range of pesticides conjugated and the different types of reactions involved, it is not surprising that GSTs comprise a group of isozymes with differing substrate specificities. GSTs are constitutively present in many plant species, including trees that grow in remote areas (62) where their only exposure to pesticides occurs by atmospheric transport (16). The GST isozymes from corn that utilize herbicides as substrates have been the most intensively studied of the plant GSTs. The GSTs represent up to 1% of the soluble protein in corn; their activity is 2-fold higher in the roots than in the shoots, and activity can be significantly increased by treatment with herbicide safeners or antidotes. The enzyme purified from corn is a dimeric protein with a molecular weight of 50 kDa. It catalyzes the conjugation of atrazine with glutathione at a rate of at least 1 nmole per g fresh weight per hour (cf. 38).

The selectivity of a number of herbicides is due to differences in the rate of GST-mediated herbicide conjugation in the resistant and susceptible species. Several herbicides cause injury to crop species when they are used at levels required to control the

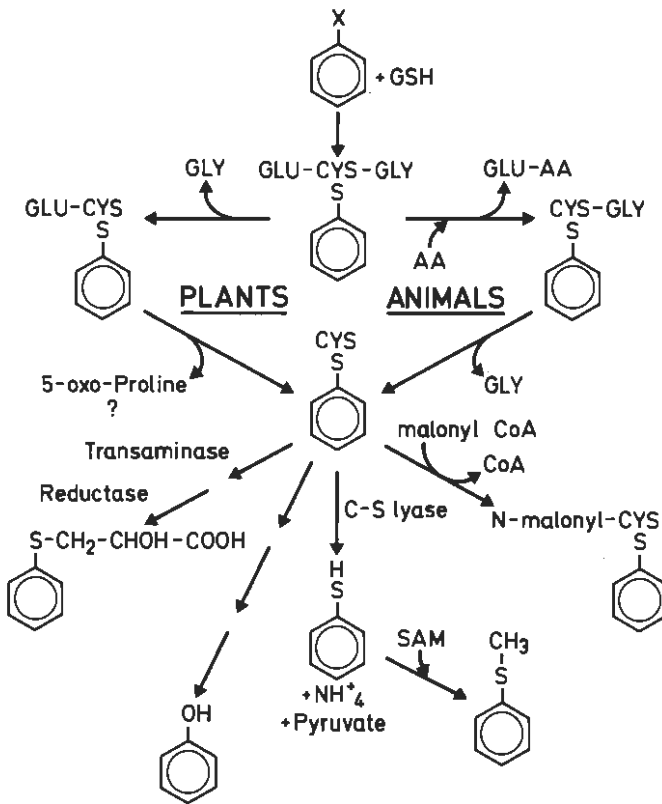

Fig. 3. Metabolism of glutathione-conjugates.

weed species. In some cases this lack of selectivity can be overcome by the addition of safeners or antidotes. These compounds decrease herbicide injury to the crop species without reducing herbicide injury to the weed species. In this way, selectivity is transferred from the herbicide to the safener. Analysis of the mode of action of safeners has shown many examples of elevated GST activity (cf. 38). Enhanced GST activity upon safener treatment in corn is due to the induction of both a constitutive isozyme (GST I) and an isozyme absent in untreated corn (GST II). To determine whether safeners act at the transcriptional level, cDNA clones that encode the major GST subunit have been isolated from corn (45, 67, 74). Using these clones as a probe for Northern analysis, a 3- to 4-fold increase in the steady state level of the corresponding mRNA was observed in corn grown from antidote treated seeds. *In vitro* translation of polysomal RNA from root tissue of safener-treated corn plants showed a 9-fold increase in mRNA activity encoding for GST (15). However, enhanced GST activity will only result in increased detoxification of pesticides if sufficient glutathione is present. Since glutathione appears to be a feedback inhibitor of its own synthesis (3), it may be assumed that the removal of glutathione for conjugation can increase its rate of synthesis. Studies with several safeners have shown enhanced glutathione levels and enhanced glutathione synthesis as a consequence of safener

treatment. In corn, even the uptake of sulfate and its reduction were stimulated by exposure to a safener (38). These observations indicate that the mode of action of safeners on glutathione conjugation and glutathione synthesis is complex and not understood at the molecular level. For a more comprehensive discussion of herbicide safeners, readers are referred to a recent review of this subject (28).

Glutathione conjugates undergo metabolism by numerous enzymatic and non-enzymatic reactions (cf. 38, 36). An abbreviated pathway that shows some of the major reactions involved in the metabolism of glutathione conjugates in animals and plants is shown in Fig. 3. Glutathione conjugates are catabolized to cysteine derivatives in both plants and animals, but it appears that the pathway leading to the cysteine derivatives is different in plants than in animals. In corn, sorghum, and sugarcane,  $\gamma$ -glutamylcysteine derivatives are produced as an intermediate. In animals, cysteinylglycine derivatives are usually formed. The cysteine derivatives can be the final metabolites of glutathione conjugates, but in fact they are usually degraded to other products (Fig. 3). Malonylcysteine derivatives are among the most abundant end-products of these reactions in plants while mercapturic acids are among the abundant reaction products in animals. The formation of malonyl derivatives may be a mechanism in plants to prevent further metabolism and to enable deposition of the metabolite in the vacuole, but experimental evidence for transport of malonylcysteine derivatives at the tonoplast membrane is lacking. Among many other pathways, degradation of glutathione conjugates to S-methyl-derivatives has been reported in plants. The C-S lyase needed in this pathway has been observed in the Cruciferae, several legumes, and in onion (cf. 38). Perhaps the most exciting recent finding was the report that hydroxylated derivatives of pesticides can be formed as the result of the catabolism of a glutathione conjugate (37).

## Conclusions

During the last decade a substantial body of descriptive information has been gathered on the metabolism and numerous functions of glutathione in plants. We have now reached the point where it is necessary to conduct studies that deal with the physiological and molecular mechanisms involved in the modulation of glutathione concentrations and glutathione-related processes. We can expect important findings in this area of research during the next decade. An increasing body of evidence suggests that glutathione plays a vital role in many processes that enable a plant to survive in an environment that is constantly changing due to anthropogenic activities. Studying these processes may help us to understand and to predict the consequences that man-made changes may have on the environment. Therefore, the ecophysiology of glutathione will be an important area of future research.

## Literature cited

1. Alosi, M.C., Melroy, D.L. and Park, R.B. 1988. The regulation of gelation of phloem exudate from *Cucurbita* fruit by dilution, glutathione, and glutathione reductase. *Plant Physiol.* 86: 1089-1094.
2. Apontoweil, P. and Berends, W. 1975. Isolation and initial characterisation of glutathione-deficient mutants of *Escherichia coli* K 12. *Biochim. Biophys. Acta* 399: 10-22.

3. Bergmann, L. and Hell, R. 1989. Properties and localisation of  $\gamma$ -glutamylcysteine synthetase from higher plants. This volume pp. 167-171.
4. Bergmann, L. and Rennenberg, H. 1978. Efflux und Produktion von Glutathion in Suspensionskulturen von *Nicotiana tabacum*. Z. Pflanzenphysiol. 88: 175-185.
5. Bielawski, C. and Joy, K.W. 1986. Reduced and oxidized glutathione and glutathione-reductase activity in tissues of *Pisum sativum*. Planta 169: 267-272.
6. Bonas, U., Schmitz, K., Rennenberg, H. and Bergmann, L. 1982. Phloem transport of sulfur in *Ricinus*. Planta 155: 82-88.
7. Buwalda, F., De Kok, L.J., Stulen, I. and Kuiper, P.J.C. 1988. Cysteine,  $\gamma$ -glutamyl-cysteine and glutathione contents of spinach leaves as affected by darkness and application of excess sulfur. Physiol. Plant. 74: 663-668.
8. Carnegie, P.R. 1963a. Isolation of a homologue of glutathione and other acidic peptides from seedlings of *Phaseolus aureus*. Biochem. J. 89: 459-471.
9. Carnegie, P.R. 1963b. Structure and properties of a homologue of glutathione. Biochem. J. 89: 471-478.
10. Carringer, R.D., Rieck, C.E. and Bush, L.P. 1978. Effect of R-25788 on EPTC metabolism in corn (*Zea mays*). Weed Sci. 26: 167-171.
11. De Kok, L.J. and Kuiper, P.J.C. 1986. Effect of short-term dark incubation with sulfate, chloride and selenate on the glutathione content of spinach leaf discs. Physiol. Plant. 68: 477-482.
12. De Kok, L.J., Maas, F.M., Godeke, J., Haaksmma, A.B. and Kuiper, P.J.C. 1986. Glutathione, a tripeptide which may function as a temporary storage of excessive reduced sulphur in H<sub>2</sub>S fumigated spinach plants. Plant & Soil 91: 349-352.
13. Dhindsa, R.S. 1987. Drought stress-induced inhibition of protein synthesis: mediation by oxidized glutathione. Plant Physiol. 83: S271.
14. Drotar, A., Phelps, P. and Fall, R. 1985. Evidence for glutathione peroxidase activities in cultured plant cells. Plant Sci. 42: 35-40.
15. Edwards, R. and Owen, W.J. 1988. Regulation of glutathione S-transferase of *Zea mays* in plants and cell cultures. Planta 175: 99-106.
16. Elling, W., 1988. Atmospheric transport of atrazine: a simple device for its detection. Environ. Pollut. 48: 77-82.
17. Esterbauer, H. and Grill, D. 1978. Seasonal variation of glutathione and glutathione reductase in needles of *Picea abies*. Plant Physiol. 61: 119-121.
18. Fahey, R.C., Brody, S. and Mikolajczyk, S.D. 1975. Changes in the glutathione thiol-disulfide status of *Neurospora crassa* conidia during germination and aging. J. Bacteriol. 121: 144-151.
19. Fahey, R.C., Brown, W.C., Adams, W.B. and Worsham, M.B. 1978a. Occurrence of glutathione in bacteria. J. Bacteriol. 133: 1126-1129.
20. Fahey, R.C., Mikolajczyk, S.D. and Brody, S. 1978b. Correlation of enzymatic activity and thermal resistance with hydration state in ungerminated *Neurospora* conidia. J. Bacteriol. 135: 868-875.
21. Fahey, R.C., Di Stefano, D., Meier, G.P. and Bryan, R.N. 1980. Role of hydration state and thiol-disulfide status in the control of thermal stability and protein synthesis in wheat embryo. Plant Physiol. 65: 1062-1066.
22. Fahey, R.C., Newton, G.L., Arrick, B., Overdank-Bogart, T. and Aley, S.B. 1984. *Entamoeba histolytica*: a eukaryote without glutathione metabolism. Science 224: 70-72.
23. Foyer, C.H. and Halliwell, B. 1976. The presence of glutathione and glutathione reductase in chloroplasts: a proposed role in ascorbic acid metabolism. Planta 133: 1-25.
24. Grill, D., Esterbauer, H. and Klösch, U. 1979. Effect of sulfur-dioxide on glutathione in leaves of plants. Environ. Pollut. 17: 187-194.
25. Grill, D., Pfeifhofer, H., Tschulik, A., Hellig, K. and Holzer, K. 1988. Thiol content of spruce needles at forest limits. Oecologia 76: 294-297.
26. Grill, E. and Zenk, M.H. 1989. Phytochelatins, the heavy-metal binding peptides of plants. This volume. 191-193.
27. Halliwell, B. 1984. Chloroplast metabolism. The structure and function of chloroplasts in green leaf cells. Oxford: Clarendon Press.
28. Hatzios, K.K. and Hoagland, R.E. 1989. Herbicide safeners: progress and prospects. New York: Academic Press.
29. Hell, R. and Bergmann, L. 1988. Glutathione synthetase in tobacco suspension cultures: catalytic properties and localization. Physiol. Plant. 72: 70-76.



30. Kasai, T. and Larsen, P.O. 1980. Chemistry and biochemistry of  $\gamma$ -glutamyl derivatives from plants including mushrooms (Basidiomycetes). In: Progress in the chemistry of organic products, Herz, W., Grisebach, H. and Kirby, G.W. eds. 39: 173-285. New York: Springer.
31. Klapheck, S. 1988 Homoglutathione: isolation, quantification and occurrence in legumes. *Physiol. Plant.* 74: 727-732.
32. Klapheck, S., Latus, C. and Bergmann, L. 1987. Localization of glutathione synthetase and distribution of glutathione in leaf cells of *Pisum sativum*. *J. Plant Physiol.* 131: 123-131.
33. Klapheck, S., Zopes, H. and Levels, H.-G., Bergmann, L. 1988. Properties and localization of the homoglutathione synthetase from *Phaseolus coccineus* leaves. *Physiol. Plant.* 74: 733-739.
34. Koike, S. and Patterson, B.D. 1988. Diurnal variation of glutathione levels in tomato seedlings. *Hort Sci.* 23: 713-714.
35. Kosower, N.S. and Kosower, E.M. 1984. Effect of G-S-S-G on protein synthesis. In: Glutathione, Flohé, L., Benöhr, H.Ch., Sies, H., Waller, H.D. and Wendel, A. eds. pp. 276-295. Stuttgart: Georg Thieme.
36. Lamoureux, G.L. and Rusness, D.G. 1985. Xenobiotic conjugation in higher plants. In: Xenobiotic conjugation chemistry, Paulson, G., Caldwell, J., Hutson, D. and Menn, J. eds. pp. 62-105. Washington, DC: American Chemical Society.
37. Lamoureux, G.L. and Rusness, D.G. 1989. Propachlor metabolism in soybean plants, excised soybean tissues and soil. *Pestic. Biochem. Physiol.* 34: 187-204.
38. Lamoureux, G.L. and Rusness, D.G. 1989. The role of glutathione and glutathione-S-transferases in pesticide metabolism, selectivity, and mode of action in plants and insects. In: Glutathione: Chemical, biochemical and medical aspects, Vol.IIIB, Series: Enzymes and cofactors, Dolphin, D., Poulson, R. and Avramovic, O. eds. pp. 153-196. New York: John Wiley & Sons.
39. Law, M.Y. and Halliwell, B. 1976. Purification and properties of glutathione synthetase from spinach (*Spinacia oleracea*) leaves. *Plant Sci.* 43: 185-191.
40. Macnicol, P.K. 1987. Homoglutathione and glutathione synthetases of legume seedlings: partial purification and substrate specificity. *Plant Sci.* 53: 229-235
41. Macnicol, P.K. and Bergmann, L. 1984. A role of homo-glutathione in organic sulphur transport to the developing mung bean seed. *Plant Sci. Lett.* 36: 219-223.
42. Meister, A. 1975 Biochemistry of glutathione. In: Metabolism of sulfur compounds, Greenberg, D.M. ed. pp. 102-188. New York: Academic Press.
43. Meister, A. 1985. Glutathione synthetase from rat kidney. In: Methods in enzymology, Meister, A. ed. Vol. 113: 393-399. New York: Academic Press.
44. Meister, A. and Anderson, M.E. 1983. Glutathione. *Annu. Rev. Biochem.* 52: 711-760.
45. Moore, R.E., Davies, M.S., O'Connell, K.M., Harding, E.I., Wiegand, R.C. and Tiemeier, D.C. 1986. Cloning and expression of a cDNA encoding a maize glutathione-S-transferase in *E. coli*. *Nucleic Acids Res.* 14: 7227-7235.
46. Newton, G.L. and Javor, B. 1985.  $\gamma$ -Glutamylcysteine and thiosulfate are the major low-molecular-weight thiols in halobacteria. *J. Bacteriol.* 161: 438-441.
47. Nieto-Sotelo, J. and Ho, T.-H.D. 1986. Effect of heat shock on the metabolism of glutathione in maize roots. *Plant Physiol.* 82: 1031-1035.
48. Owens, R.A. and Hartman, P.E. 1986. Export of glutathione by some widely used *Salmonella typhimurium* and *Escherichia coli* strains. *J. Bacteriol.* 168: 109-114.
49. Price, C.A. 1957. A new thiol in legumes. *Nature* 180: 148-149.
50. Rennenberg, H. 1981. Differences in the use of cysteine and glutathione as sulfur source in photoheterotrophic tobacco suspension cultures. *Z. Pflanzenphysiol.* 105: 31-40.
51. Rennenberg, H. 1982. Glutathione metabolism and possible biological roles in higher plants. *Phytochemistry* 21: 2771-2781.
52. Rennenberg, H. and Bergmann, L. 1979. Einfluß von Ammonium und Sulfat auf die Glutathion-Produktion in Suspensionskulturen von *Nicotiana tabacum*. *Z. Pflanzenphysiol.* 92: 133-142.
53. Rennenberg, H., Birk, C. and Schaer, B. 1982. Effect of N,N-diallyl-2,2-dichloroacetamide (R-25788) on efflux and synthesis of glutathione in tobacco suspension cultures. *Phytochemistry* 21: 5-8.
54. Rennenberg, H., Kemper, O. and Thoene, B. 1989. Recovery of sulfate transport into heterotrophic tobacco cells from inhibition by reduced glutathione. *Physiol. Plant.* 76: 271-276.
55. Rennenberg, H., Polle, A. and Grundel, I. 1983. 5-Oxo- prolinase activity in tobacco suspension cultures: regulation by sulfate nutrition. *Physiol. Plant.* 59: 61-66.
56. Rennenberg, H., Polle, A., Martini, N. and Thoene, B. 1988. Interaction of sulfate and glutathione

- transport in cultured tobacco cells. *Planta* 176: 68-74.
57. Rennenberg, H., Schmitz, K. and Bergmann, L. 1979. Long-distance transport of sulfur in *Nicotiana tabacum*. *Planta* 147: 57-62.
  58. Rennenberg, H., Steinkamp, R. and Kesselmeier, J. 1981. 5-Oxo-prolinase in *Nicotiana tabacum*: catalytic properties and subcellular localization. *Physiol. Plant.* 52: 211-216.
  59. Rennenberg, H., Steinkamp, R. and Polle, A. 1980. Evidence for the participation of a 5-oxo-prolinase in degradation of glutathione in *Nicotiana tabacum*. *Z. Naturforsch.* 35c: 708-711.
  60. Rennenberg, H. and Thoene, B. 1987. The mobility of sulphur in higher plants. In: Proceedings of the international symposium elemental sulphur in agriculture, Vol. 2: 701-707. Nice.
  61. Robinson, N.J. and Jackson, P.J. 1986. 'Metallothionein-like' metal complexes in angiosperms; their structure and function. *Physiol. Plant.* 67: 499-506.
  62. Schröder, P., Rusness, D.G., Lamoureux, G.L. and Rennenberg, H. 1989. Glutathione-S-transferases in spruce trees. *Pestic. Biochem. Physiol.*, submitted.
  63. Seelig, G.F. and Meister, A. 1985. Glutathione biosynthesis;  $\gamma$ -glutamylcysteine synthetase from rat kidney. In: *Methods in enzymology*, Meister, A. ed. Vol. 113: 379-392. New York: Academic Press.
  64. Schupp, R. and Rennenberg, H. 1988. Diurnal changes in the glutathione content of spruce needles (*Picea abies* L.). *Plant Sci.* 57: 113-117.
  65. Sekura, R. and Meister, A. 1977.  $\gamma$ -Glutamylcysteine synthetase. *J. Biol. Chem.* 252: 2599-2605.
  66. Setlow, B. and Setlow, P. 1977. Most of the coenzyme A in dormant spores of *Bacillus megaterium* is in disulfide linkage to protein. *Biochem. Biophys. Res. Commun.* 75: 45-50.
  67. Shah, D.M., Hironaka, C.M., Wiegand R.C., Harding, E.I., Krivi, G.G. and Tiemeier, D.C. 1986. Structural analysis of a maize gene coding for glutathione-S-transferase involved in herbicide detoxification. *Plant Molec. Biol.* 6: 203-211.
  68. Shigeoka, S., Onishi, T., Nakano, Y. and Kitaoka, S. 1987. Photoinduced biosynthesis of glutathione in *Euglena gracilis*. *Agric. Biol. Chem.* 51: 2257-2258.
  69. Smith, I.K., Kendall, A.C., Keys, A.J., Turner, J.C. and Lea, P.J. 1985. The regulation of the biosynthesis of glutathione in leaves of barley (*Hordeum vulgare*). *Plant Sci. Lett.* 41: 11-18.
  70. Steffens, J.C. and Williams, B. 1987. Increased activity of  $\gamma$ -glutamylcysteine synthetase in cadmium-resistant tomato cells. *Plant Physiol.* 83: S666.
  71. Steinkamp, R. and Rennenberg, H. 1985. Degradation of glutathione in plant cells: evidence against the participation of  $\gamma$ -glutamyl-transpeptidase. *Z. Naturforsch.* 40c: 29-33.
  72. Steinkamp, R., Schweihofen, B. and Rennenberg, H. 1987.  $\gamma$ -Glutamylcyclotransferase in tobacco suspension cultures: catalytic properties and subcellular localization. *Physiol. Plant.* 69: 499-503.
  73. Tabor, H. and Tabor, C.W. 1975. Isolation, characterization and turnover of glutathionylspermidine from *Escherichia coli*. *J. Biol. Chem.* 250: 2648-2654.
  74. Wiegand, R.C., Shah, D.M., Mozer, T.J., Harding, E.I., Diaz-Collier, J., Saunders, C., Jaworski, E.G. and Tiemeier, D.C. 1986. Messenger RNA encoding a glutathione-S-transferase responsible for herbicide tolerance in maize is induced in response to safener treatment. *Plant Molec. Biol.* 7: 235-243.
  75. Wolosiuk, R.A. and Buchanan, B.B. 1977. Thioredoxin and glutathione regulate photosynthesis in chloroplasts. *Nature* 266: 565-567.

# SYNTHESIS, STRUCTURE AND EVOLUTIONARY RELATIONSHIPS OF SULFUR-RICH SEED PROTEINS IN HIGHER PLANTS

Martin Kreis

*AFRC Institute of Arable Crops Research, Biochemistry Department,  
Rothamsted Experimental Station, Harpenden, Herts., AL5 2JQ, UK.*

## Contents

Introduction	67
Occurrence, composition, structure and evolutionary relationships of various sulfur-rich seed proteins	68
Biosynthesis and processing of some sulfur-rich proteins	71
Structural and evolutionary relationships between sulfur-rich proteins from different species	72
Acknowledgements	74
Literature cited	74

## Introduction

Seed proteins have traditionally been divided into four classes, namely: albumins, globulins, glutelins and prolamins, on the basis of their extraction and solubility in different solvents. Dicotyledonous plants contain mainly albumins and globulins, while the *Gramineae* (which includes cultivated cereals) usually contain large amounts of alcohol-soluble prolamins rich in proline and glutamine.

The globulins account for about 70% of the seed proteins of legumes and other dicotyledonous plants and are composed of two major protein families, the 11S (or legumin-like) and the 7S (or vicilin-like) proteins, which have been extensively characterized (for a review see 13). These groups of proteins contain relatively low amounts of sulfur-containing amino acids, which may limit the nutritional value of the whole seed (17). The globulins, however, provide the major source of nitrogen utilized by the developing seedling (21, 22).

The prolamins comprise the major storage proteins of all cereals except oats and rice. Those of the major temperate cereals, wheat, barley and rye, can be classified into three groups, called the sulfur-rich (S-rich), sulfur-poor (S-poor) and HMW prolamins, on the basis of their amino acid composition and genetic control (38). Although the major zeins of maize are poor in S-amino acids, two minor groups (Z10 and Z15 zeins) are S-rich. During the last decade the genes encoding cereal prolamins have been studied in great detail.

The seed albumins are a very diverse group of proteins and are usually classified as '2S' proteins. They are exceptionally rich in sulfur-containing amino acids, and

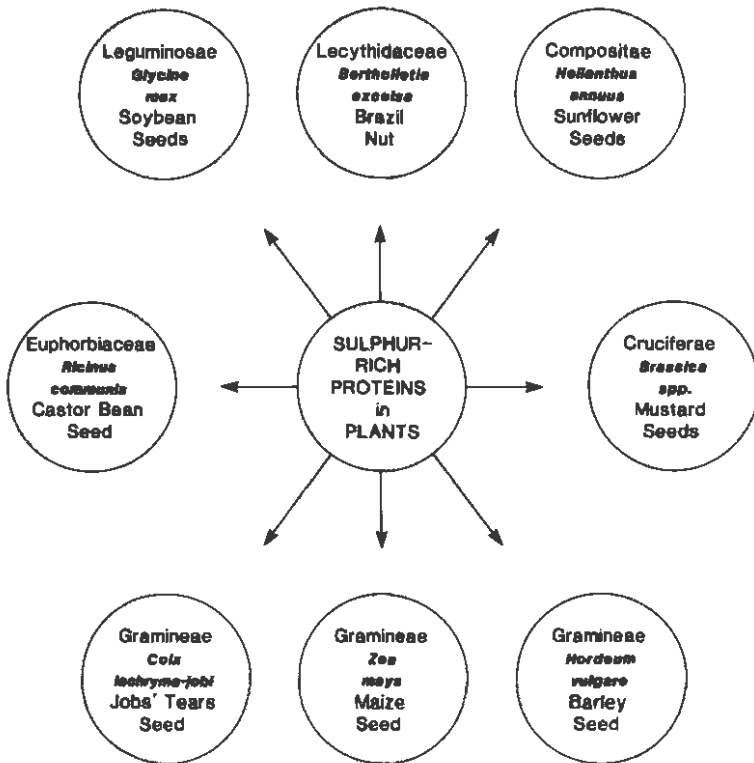

Fig. 1. Sulfur-rich proteins occur in diverse species of plants.

the nutritional value of seed proteins in animal diets is often correlated with their albumin contents (7).

Because of their abundance and importance, these various groups of proteins have been studied in great detail. More recently the genes encoding them have been isolated and their control of expression is being elucidated. Much emphasis is being put on improving the content of sulfur-containing amino acids by altering the expression of S-rich proteins in seeds.

This short review describes the occurrence, the structure, and the evolutionary relationship of various S-rich proteins of monocotyledonous and dicotyledonous plants.

### Occurrence, composition, structure and evolutionary relationships of various sulfur-rich seed proteins

Sulfur-rich proteins occur in many diverse species of higher plants. Figure 1 lists the eight species that will be discussed in this short review. The S-rich proteins present in these can be classified into three main groups: 1) 2S proteins (albumins), 2) protease and amylase inhibitors and 3) S-rich prolamins (see also Fig. 2).

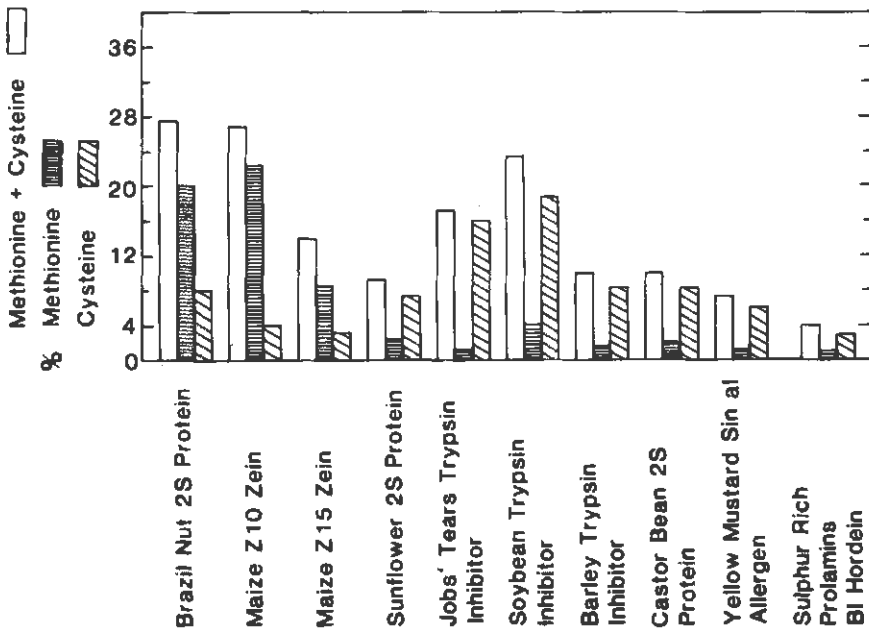

Fig. 2. The amounts of methionine and cysteine (mol %) in a number of sulfur-rich seed proteins from monocotyledonous and dicotyledonous plants including brazil nut 2S protein (3, 4, 16, 40) maize Z10 zein (24, 25), maize Z15 zein (31), sunflower 2S protein (1, 2), Job's tears trypsin inhibitor (6), soybean trypsin inhibitor (6), barley trypsin inhibitor (33), castor bean 2S protein (36), yellow mustard Sinal allergen (32), B1 hordein (19).

The 2S proteins have sedimentation values of about 2 and, apart from their high contents of arginine, glutamine and asparagine, are exceptionally rich in cysteine and, in some proteins, also methionine. They probably function as storage proteins. The 2S protein from brazil nut (*Bertholletia excelsa*) is exceptional in that it contains about 28% of methionine + cysteine by weight (Fig. 2) (5, 41) and accounts for about 30% of the total seed proteins (Fig. 3). The methionine and cysteine contents of various other sulfur-rich 2S albumin proteins are shown in Fig. 2. Although their cysteine contents are high, none contain as much methionine as the brazil nut 2S protein. The Z10 and Z15 zeins (S-rich prolamins) of maize (*Zea mays* L.) (24, 25, 31) are also rich in both sulfur amino acids containing about 26% and 15% methionine + cysteine respectively. These two proteins together with the 2S brazil nut protein represent the most methionine-rich proteins so far isolated and characterized. However, the Z10 and Z15 zeins account for only a minor fraction of the total proteins of the maize seed.

Because these proteins contain large amounts of methionine, it has been suggested (see 3, 23) that the nutritional quality of seeds deficient in sulfur amino acids could be improved by genetic engineering.

The S-rich prolamins of barley, wheat and rye account for a larger proportion of the total seed proteins (about 40%) (39). Although they contain only about 4% methionine + cysteine residues (19, 20), they contribute about 25% of the total sulfur containing amino acids of the seed (10).

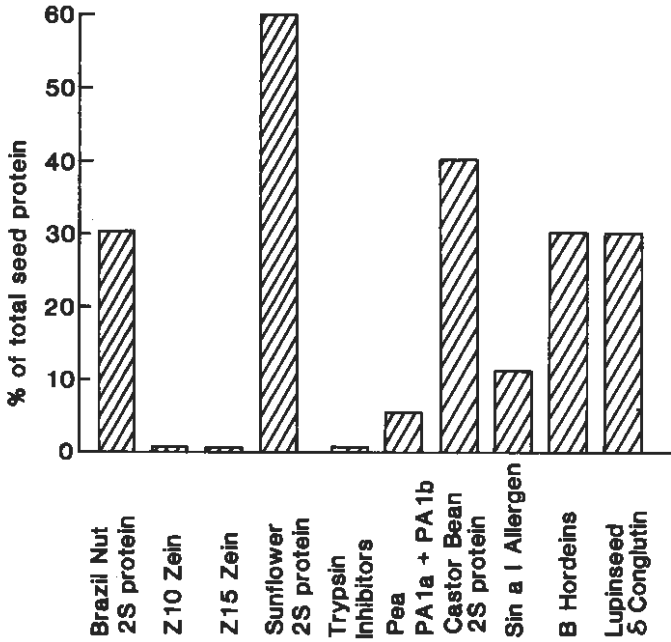

Fig. 3. The contribution of various sulfur-rich proteins to the total seed proteins. The data are taken from Youle and Huang (41), Lilley and Inglis (29), Antunes and Markakis (5), Shewry *et al.* (39), Higgins *et al.* (22), Sharief and Li (36), Ohtsubo *et al.*, (34).

Another group of S-rich seed proteins comprises the Bowman-Birk type protease inhibitors such as the Job's tears and soybean trypsin inhibitors listed in Fig. 2, and the trypsin inhibitor of barley. These proteins contain high levels of cysteine but only between 2% and 4% methionine. Whereas most of the 2S proteins and the S-rich prolamins contribute significantly to the total S-content of the seed, the enzyme inhibitors like the Z10 and Z15 zeins are present in much smaller amounts.

Other 2S albumins not listed in Fig. 2 are the pea PA1a and PA1b proteins (21, 22). They collectively contribute about 50% of the total sulfur-containing amino acids of the pea seed, but account for only about 4.5% of the total seed proteins.

It has been shown previously that the relative amount of different proteins deposited in the developing grain is influenced by the sulfur and nitrogen nutrition (8, 9, 12, 22, 35, 37). Sulfur starvation of barley plants results in major changes in the amount and composition of the prolamins (storage proteins), and of certain components of the salt-soluble fraction. Electrophoretic analyses of barley seed proteins demonstrated that the prolamins were depleted of S-rich B hordeins (37). Rahman *et al.* (35) also showed that the population of mRNAs coding for B hordein polypeptides was reduced in S-deficient seeds of barley, indicating that the control could be at the level of transcription. Similarly, Higgins *et al.* (22) reported

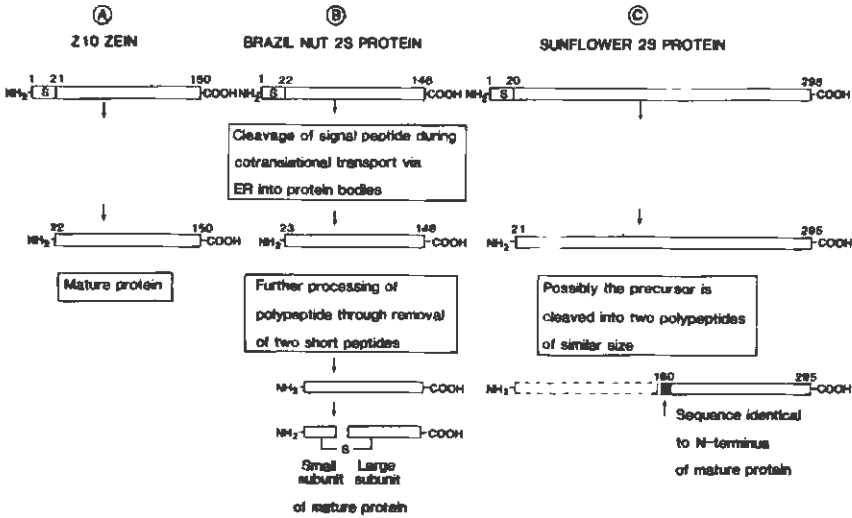

Fig. 4. Biosynthesis and processing of the maize Z10 zein, the brazil nut 2S protein and the sunflower 2S protein. For details see Hoffman *et al.* (23), Sun *et al.* (40), de Castro *et al.* (16), Allen *et al.* (2).

that developing pea seeds under sub-optimal sulfur nutrition accumulated reduced levels of PA1a and PA1b and contained reduced amounts of PA1 mRNA during seed development. *In vitro* transcription studies showed that the reduced levels of PA1 mRNA were the result of reduced post-transcriptional stability and not an altered rate of transcription of the PA1 gene. During normal seed development, however, the levels of PA1 mRNA seem to be under transcriptional control.

**Biosynthesis and processing of some sulfur-rich proteins**

The synthesis and deposition of a number of 2S albumins has previously been studied in great detail including the 2S proteins of castor bean (11, 30), *Brassica napus* (15, 18), pea 2S protein (21, 22), sunflower 2S protein (1, 2) and brazil nut 2S protein (16, 40). These proteins are synthesised as larger precursors which are then extensively processed before deposition into protein bodies in the embryo (*e.g.* peas) or endosperm (*e.g.* castor bean) of the seed. In Fig. 4 three pathways of synthesis and processing of sulfur-rich proteins are examined. The Z10 zeins do not undergo any further post-translational modifications and are stored in protein bodies as mature proteins, the brazil nut and sunflower 2S proteins are further processed by endo-proteolytic cleavage in the vacuole or protein bodies to produce the mature subunits.

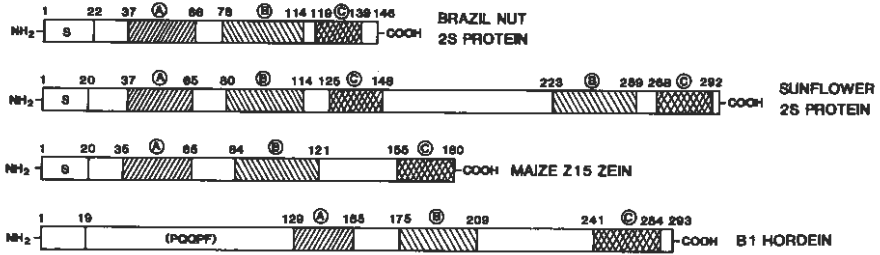

Fig. 5. Schematic representations of the positions of the related regions A, B, and C in sulfur-rich proteins from different species. Similar regions of homology are present in several other sulfur-rich proteins including barley trypsin inhibitor (33), but these regions are absent in the sulfur-rich Z10 zein. The precursor forms of the proteins are shown and 'S' indicates the signal sequence.

Sun *et al.* (40) have shown through *in vitro* translation studies that the brazil nut 2S protein is synthesised as an 18 kDa precursor. *In vivo* labelling experiments suggest that there are two intermediate precursors of 15 and 12 kDa, before generating the small (3 kDa) and large (9 kDa) subunits linked by inter-chain disulfide bonds. The structure of the mature brazil nut 2S protein is similar to those observed for the storage proteins of castor bean and *Brassica napus*, although the precursor polypeptides of the latter are much larger. The sunflower 2S protein is processed from a 38 kDa precursor polypeptide, resulting in a mature protein of 18 kDa composed of a large polypeptide containing one or more intra-chain disulfide linkages (2).

### Structural and evolutionary relationships between sulfur-rich proteins from different species

Computer-assisted comparisons of the 2S albumins, and the S-rich prolamins show the presence of three conserved regions (called A, B and C) (see 26, 27, 28). Schematic representations of the relative positions of the A, B and C regions in the brazil nut 2S protein, the sunflower 2S protein and B1 hordein are shown in Fig. 5. Similar regions are also present in the barley trypsin inhibitor and related inhibitors of hydrolytic enzymes from cereals, in the 2S proteins of castor bean, oilseed rape, brazil nut and mustard and in other S-rich prolamins (26). The structure of B hordein consists of an N-terminal repetitive domain based on short repeat motifs that are rich in proline and glutamine but contain no cysteine, and a larger non-repetitive C-terminal domain, poor in proline but containing several cysteine residues. The Z15 zein shown in Fig. 5 is one of the few prolamins groups that do not contain repeated sequences, but a methionine-rich region is present (31). The mature 2S proteins consist of two subunits (containing regions A and B + C respectively) associated by inter-chain disulfide bonds as shown for the brazil nut protein and the rape seed napin in Fig. 4 and 5 respectively. cDNA cloning has shown that these subunits are synthesised as a single precursor (see Figs. 4, 5 and 6) followed by proteolytic cleavage.



## 1. ENZYME INHIBITORS

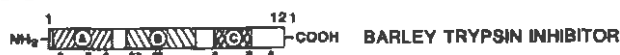

## 2. 2S STORAGE PROTEINS

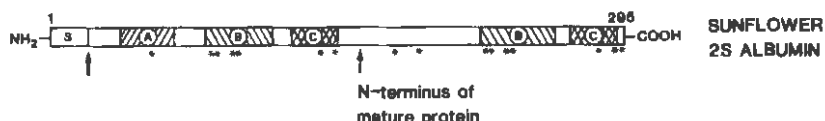
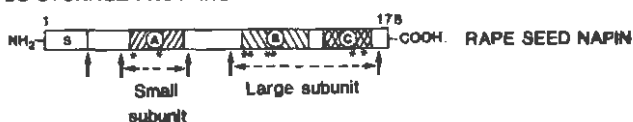

## 3. PROLAMINS

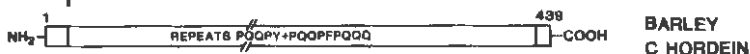

Fig. 6. Evolutionary relationships between sulfur-rich proteins from different crops. (For details see 26,28). Asterisks indicate the position of cysteine residues).

The three conserved regions (A, B & C) are about 30-40 residues long and very rich in methionine and/or cysteine. When the various proteins are aligned to maximize homology, (26, 27, 28) the arrangement of cysteines and often leucines is seen to be conserved. For example, of the 8 cysteine residues present in the brazil nut 2S protein, 5 are also present in B1 hordein, 6 are present in the sunflower 2S protein, and 8 in the barley trypsin inhibitor. In these the conserved cysteines include a characteristic double cysteine. The most interesting observation is the conservation of the LQCCQQ/EL motif in most sequences and the invariance of the two cysteines at positions 4 and 5 and leucine at position 8. The conservation of cysteines in other proteins is well documented and may be related to their role in stabilizing the folded structure of the protein and interactions between individual subunits.

In the case of the brazil nut 2S protein, the deduced amino acid sequence shows that methionine residues mostly occur in pairs or clusters and about half are present in the B and C regions (see Fig. 3 and Fig. 5). Two clusters are present (3), one each in

regions B and C, where they are interspersed with arginine residues. In region B, 5 out of the 6 amino acids which form the cluster are methionine residues and four of these are contiguous.

The A, B and C regions also appear to be related to each other (26, 27), suggesting that they have evolved from a short ancestral gene. This gene encoding a protein of about 30 residues was probably triplicated to give a gene encoding a protein of three identical domains which diverged to give regions A, B and C. The subsequent divergence of the different types of proteins has occurred by the insertion of sequences between and flanking A, B and C. The enzyme inhibitors have diverged least, only by substitutions and small insertions. In the case of most of the 2S albumins, the events include the insertion of a proteolytic cleavage linker between A and B (see Fig. 6).

### Acknowledgements

The work was partly carried out in the framework of Contract BAP-0099 U.K. of the Biotechnology Action Programme of the Commission of the European Communities.

### Literature Cited

1. Allen, R.D., Cohen, E.A., vander Haar, R.A., Orth, K.A., Ma, D.P., Messler, C.L. and Thomas, T.L. 1987. Expression of embryo specific genes in sunflower. In: UCLA symposium on molecular approaches to developmental biology, Davidson, E.H. and Firtel, eds., Alan R. Liss, New York.
2. Allen, R.D., Cohen, E.A., vander Haar, R.A., Adams, C.A., Ma, D.P., Nessler, C.L. and Thomas, T.L. 1987. Sequence and expression of a gene encoding an albumin storage protein in sunflower. *Mol. Gen. Genet.* 210: 211-218.
3. Altenbach, S.B., Pearson, K.W., Leung, F.W. and Sun, S.S.M. 1987. Cloning and sequence analysis of a cDNA encoding a brazil nut protein exceptionally rich in methionine. *Plant Mol. Biol.* 8: 239-250.
4. Ampe, C., van Damme, J., de Castro, L.A.B., Sampaio, M.J.A.M., van Montagu, M. and Vandekerckhove, J. 1986. The amino acid sequence of the 2S sulphur-rich proteins from seeds of brazil nut (*Bertholletia excelsa* H.B.K.). *Eur. J. Biochem.* 159: 597-609.
5. Antunes, A.J. and Markakis, P. 1977. Protein supplementation of navy beans with brazil nuts. *J. Agric. Food Chem.* 25: 1096-1098.
6. Ary, M.B., Shewry, P.R. and Richardson, M. 1988. The amino acid sequence of a cereal Bowman-Birk type trypsin inhibitor from seeds of Job's tears (*Coix lachryma-jobi* L.). *FEBS Lett.* 229: 111-118.
7. Bajaj, S., Mickelsen, O., Lillevik, H.A., Baker, L.R., Bergen, W.G. and Gill, J.L. 1971. Prediction of protein efficiency ratio of peas from their albumin content. *Crop Sci.* 11: 813-815.
8. Blagrove, R.J., Gillespie, J.M., and Randall, P.J. (1976). Effect of sulphur supply on the seed globulin composition of *Lupinus angustifolius*. *Australian J. Plant Physiol.* 3: 173-184.
9. Bottacin, A., Smith, K., Mifflin, B.J., Shewry, P.R. and Bright, S.W.J. 1985. Regulation of storage protein synthesis by sulphur and nitrogen nutrition in cultured immature caryopses of barley. *J. Exp. Bot.* 36: 140-148.
10. Bright, S.W.J. and Shewry, P.R. 1983. Improvement of protein quality in cereals. *CRC Critical Rev. in Plant Sci.* 1: 1, 49-93.

11. Butterworth, A.G. and Lord, J.M. 1983. Ricin and *Ricinus communis* agglutinin subunits are all derived from a single-size polypeptide precursor. *Eur. J. Biochem.* 137: 57-65.
12. Byers, M., Franklin, J. and Smith, S.J. 1987. The nitrogen and sulphur nutrition of wheat and its effect on the composition and baking quality of the grain. *Aspects of Appl. Biol.* 15: 337-344.
13. Casey, R., Damoney, C. and Ellis, N. 1986. Legume storage proteins and their genes. In: *Plant molecular and cell biology*, Mifflin, B.J. ed., vol. 3, pp. 1-96, Oxford Surveys.
14. Chandler, P.M., Spencer, D., Randall, P.J. and Higgins, T.J.V. 1984. Influence of sulphur nutrition and development patterns of some major pea seed proteins and their mRNAs. *Plant Physiol.* 75: 651-657.
15. Crouch, M.L., Tenbarge, K.M., Simon, A.E. and Ferl, R. 1983. cDNA clones for *Brassica napus* seed storage proteins: evidence from nucleotide sequence analysis that both subunits of napin are cleaved from a precursor polypeptide. *J. Mol. Appl. Genet.* 2: 273-283.
16. de Castro, L.A.B., Lacerda, Z., Aramayo, R.A., Sampaio, M.J.A.M. and Gander, E.S. 1987. Evidence for a precursor molecule of brazil nut 2S seed proteins from biosynthesis and cDNA analysis. *Mol. Gen. Genet.* 206: 338-343.
17. Derbyshire, E., Wright, D.J. and Boulter, D. 1976. Legumin and vicilin storage proteins of legume seeds. *Phytochemistry* 15: 3-24.
18. Ericson, M.L., Rödin, J., Lenman, M., Glimelius, K., Josefson, L.-G., and Rask, L. 1986. Structure of the rapeseed 1.7S storage protein, Napin, and its precursor. *J. Biol. Chem.* 261: 14576-14581.
19. Forde, B.G., Kreis, M., Williamson, M.S., Ery, R.P., Pywell, J., Shewry, P.R., Bunce, N. and Mifflin, B.J. 1985. Short tandem repeats shared by B- and C-hordein cDNAs suggest a common evolutionary origin for two groups of cereal storage protein genes. *EMBO J.* 4: 9-15.
20. Forde, B.G., Heyworth, A., Pywell, J. and Kreis, M. 1985. Nucleotide sequence of a B1 hordein gene and the identification of possible regulatory elements in endosperm genes from barley, wheat and maize. *Nucleic Acids Res.* 13: 7327-7339.
21. Higgins, T.J.V. 1984. Synthesis and regulation of major proteins in seeds. *Annu. Rev. Plant Physiol.* 35: 191-221.
22. Higgins, T.J.V., Chandler, P.M., Randall, P.J., Spencer, D., Beach, L.R., Blagrove, R.J., Koritt, A.A. and Inglis, A.S. 1986. Gene structure, protein structure and regulation of the synthesis of a sulphur-rich protein in pea seeds. *J. Biol. Chem.* 261: 11124-11130.
23. Hoffman, L.M., Donaldson, D.D., Bookland, R., Rashka, K. and Herman, E.M. 1987. Synthesis and protein body deposition of maize 15-kd zein in transgenic tobacco seeds. *EMBO J.* 6: 3213-3221.
24. Kirihaara, J.A., Petri, J.B. and Messing, J. 1988. Isolation and sequence of a gene encoding a methionine-rich 10-kDa zein protein from maize. *Gene* 71: 359-370.
25. Kirihaara, J.A., Hunsperger, J.P., Mahoney, W.C., Messing, J.D. 1988. Differential expression of a gene for a methionine-rich storage protein in maize. *Mol. Gen. Genet.* 211: 477-484.
26. Kreis, M., Forde, B.G., Rahman, S., Mifflin, B.J. and Shewry, P.R. 1985. Molecular evolution of the seed storage proteins of barley, rye and wheat. *J. Mol. Biol.* 183: 449-502.
27. Kreis, M., Shewry, P.R., Forde, B.G., Forde, J. and Mifflin, B.J. 1985. Structure and evolution of seed storage proteins and their genes with particular reference to those of wheat, barley and rye. In: *Plant cell and molecular biology*, Mifflin, B.J. ed., vol. 2, pp. 253-317, Oxford Surveys.
28. Kreis, M. and Shewry, P.R. 1989. Unusual features of cereal seed protein structure and evolution. *Bioessays* 10: 201-207.
29. Lilley, G.G. and Inglis, A.S. 1986. Amino acid sequence of conglutin S, a sulphur-rich seed protein of *Lupinus augustifolius* L. *FEBS Lett.* 195: 235-241.
30. Lord, J.M. 1985. Synthesis and intracellular transport of lectin and storage protein precursors in endosperm from castor bean. *Eur. J. Biochem.* 146: 403-409.
31. Marks, M.D., Lindell, J.S. and Larkins, B.A. 1985. Nucleotide sequence analysis of zein mRNAs from maize endosperm. *J. Biol. Chem.* 260: 16451-16459.
32. Menendez-Arias, L., Moneo, I., Dominguez, J. and Rodriguez, R. 1988. Primary structure of the major allergen of yellow mustard (*Sinapis alba* L.) seed, Sinal. *Eur. J. Biochem.* 177: 159-166.
33. Odani, S., Koide, T. and Ono, T. 1983. The complete amino acid sequence of barley trypsin inhibitor. *J. Biol. Chem.* 258: 7998-8003.
34. Ohtsubo, K., Yanagi, S.O. and Yanase, H. 1985. Properties of a trypsin inhibitor from Job's tears (*Coix lacryma-jobi* L. var. *Ma-Yuem* Stapf). *Agric. Biol. Chem.* 49: 1985-1991.
35. Rahman, S., Shewry, P.R., Forde, B.G., Kreis, M. and Mifflin, B.J. 1983. Nutritional control of storage protein synthesis in developing grain of barley (*Hordeum vulgare* L.). *Planta* 159: 366-372.

36. Sharief, F.S. and Li, S.S-L. 1982. Amino acid sequence of small and large subunits of seed storage protein from *Ricinus communis*. J. Biol. Chem. 257: 14753-14759.
37. Shewry, P.R., Franklin, J. Parmar, S., Smith, S.J. and Mifflin, B.J. 1983. The effects of sulphur starvation on the amino acid and protein compositions of barley grain. J. Cer. Sci. 1: 21-31.
38. Shewry, P.R., Mifflin, B.J. and Kasarda, D.D. 1984. The structural and evolutionary relationships of the prolamin storage proteins of barley, rye and wheat. Phil. Trans. Roy. Soc. Lond. B. 304: 297-308.
39. Shewry, P.R. and Mifflin, B.J. 1985. Seed storage proteins of economically important cereals. In: Advances in cereal science and technology, Pomeranz, Y. ed., vol. 7, pp. 1-83. AACC, St Paul, Minn.
40. Sun, S.S.M., Altenbach, S.B. and Leung, F.W. 1987. Properties, biosynthesis and processing of a sulphur-rich protein in brazil nut (*Bertholletia excelsa* H.B.K.). Eur. J. Biochem. 162: 477-483.
41. Youle, R., Huang, A.H.C. 1981. Occurrence of low molecular weight and high cysteine containing albumin storage protein in oilseeds of diverse species. Am. J. Bot. 68: 44-48.

# PLANT SULFOLIPIDS

K.F. Kleppinger-Sparace‡, S.A. Sparace‡ and J.B. Mudd†

‡*Department of Plant Science, Macdonald College of McGill University, Ste. Anne-de-Bellevue, Quebec, Canada H9X 1C0* and †*The Plant Cell Research Institute, 6560 Trinity Court, Dublin, CA 94568, USA*

## Contents

Introduction	77
Sulfoquinovosyldiacylglycerol	77
– The sulfoquinovose moiety	78
– The diacylglycerol moiety	80
Catabolism of SQDG	81
Other higher plant sulfolipids	82
Algal sulfolipids	83
Conclusions	85
Literature cited	86

## Introduction

There are now many lipophilic biochemical compounds known in the plant kingdom which contain sulfur. In this review, we will utilize the terminology of Haines (18); sulfonolipid for those lipids containing a sulfonic acid, sulfatide for those containing a sulfonic acid and sulfocholine for the sulfonium derivative of choline. In the past, there has been a tendency to use the terms 'sulfolipid' and 'sulfoquinovosyldiacylglycerol' interchangeably. However, here the word 'sulfolipid' will include all lipophilic biochemicals which contain sulfur. This operational definition is comparable to a definition of lipids to include all biochemicals soluble in organic solvents. Both definitions encompass a range of biochemical structures. Here, we will concentrate on the biosynthesis of the sulfolipids.

## Sulfoquinovosyldiacylglycerol

Sulfoquinovosyldiacylglycerol (SQDG) has most recently been reviewed by Mudd and Kleppinger-Sparace (41). However, the reviews of Harwood (23) and Benson (3) are still enlightening.

Benson and his laboratory played a key role in the discovery, characterization and research on the metabolism of SQDG. SQDG was discovered by A. Benson and coworkers in 1953 utilizing radiolabelled sulfate. In 1959, Benson *et al.* (4) were the first to report its occurrence in photosynthetic bacteria, algae and higher plants and to characterize it as a glycerolipid with a sugar headgroup. Two years later, they con-

firmed the structure as 1,2-diacyl-3-(6-sulfo- $\alpha$ -D-quinovopyranosyl)-L-glycerol (10). At that time, this was the only known sulfur-containing glycerolipid and the only lipid, plant or animal, containing a carbon-sulfur bond. SQDG was then termed 'the plant sulfolipid', a name strongly associated with it even now.

Biosynthesis of SQDG has been studied *in vivo* and *in vitro* in algae and higher plants. SQDG synthesis is rapid, as Benson & Shibuya (5) first indicated, since labelled precursors are incorporated within minutes. Benson (3) indicates the importance of its location primarily in photosynthetic tissues. The lack of SQDG in animal tissues, which lack both sulfate reduction and carbon fixation, and its presence in *Euglena*, algae and higher plants emphasizes the importance of carbon fixation in SQDG biosynthesis. This aspect has received little attention.

The biosynthesis of SQDG remains a challenging problem. Lipid biochemists have long taken advantage of water-soluble precursors such as acetate or glycerol to study fatty acid or glycerolipid synthesis since the product and substrate are easily separated by partitioning between water and an organic solvent. However, the difficulty in studies of SQDG synthesis lies in determining the intermediates between sulfate and SQDG since numerous water soluble sulfur compounds are formed, most unrelated to the synthesis of SQDG, as evident in the chromatograms of Shibuya *et al.* (54).

Problems inherent in studies of SQDG include (1) the different uptake kinetics of the various sulfur precursors (14, 40), (2) the addition of sulfur precursors on top of preexisting sulfur pools which can alter the direction of normal sulfur metabolism (51), and (3) prolonged incubation times in which degradation products and other nonrelated sulfur compounds are formed as various sulfur compounds are metabolized back to sulfate. Results with sulfite and molybdate need careful interpretation since sulfite is very reactive in general and since molybdate not only inhibits sulfate activation but also affects sulfate uptake (14, 20), sulfite oxidation (55) and can form complexes with amino groups and SH groups (25). Also, results in the *Euglenophyta* may differ from those in other algae and higher plants because sulfate metabolism is partitioned between the mitochondria and chloroplast, the reductive enzymes localized mainly in the mitochondria (50). Despite these problems, much can still be learned from these studies.

### *The sulfoquinovose moiety*

Many precursors of the sulfoquinovose moiety have been proposed: sulfate, cysteic acid, cysteine, sulfite, APS, PAPS, and UDP-sulfoquinovose (UDP-SQ). For some there is experimental evidence supporting their involvement and for others the argument is mainly by analogy with other biosynthetic systems.

a). Sulfate is a suitable precursor of SQDG synthesis. In intact seedlings, SQDG is synthesized in roots (40) as well as in leaves (22, 40), indicating root plastids also synthesize SQDG. Synthesis in photosynthetic tissues is stimulated upon illumination. Isolated chloroplasts, currently the most sophisticated system for studies of SQDG, also incorporate sulfate into SQDG (16, 31) but require light (31), or the addition of ATP directly or indirectly (32). After incubating chloroplasts with  $^{35}\text{SO}_4^{2-}$ , a nucleotide sugar fraction could in theory be obtained from the water soluble fraction and further analyzed for labelled UDP-SQ. There has been no such report to date.

b). APS and PAPS have been successfully utilized as precursors (24, 33) as one might expect since it is unlikely sulfate is incorporated into SQDG without first activation and most likely one reductive step. PAPS was a good precursor in the *Chlamydomonas reinhardtii* system (24). APS was not tested in that system but in spinach chloroplasts was preferred over PAPS and sulfate (33). Verification that APS and/or PAPS are involved has practical advantages since these precursors would eliminate the need for illumination, the addition of ATP and possibly the addition of other cofactors, simplifying the system for studying perturbations caused by inhibitors.

c). The utilization of cysteic acid in SQDG synthesis by *Euglena gracilis* is quite convincing (9). The preference of cysteic acid over sulfate and the incorporation of label from both the sulfur and the carbon moieties of cysteic acid into the sulfoquinovose of SQDG implied a three carbon unit as an intermediate. Cysteic acid was also utilized as a precursor in higher plants (22), but the result has been challenged. Cysteic acid was a poor precursor of SQDG in spinach seedlings and failed to dilute the label introduced from sulfate (40). In groundnut leaf discs, cysteic acid was not incorporated into SQDG but only metabolized to sulfoacetic acid (14). Although cysteic acid is not a good precursor in higher plants, three-carbon compounds may still be the precursors of sulfoquinovose. DHAP stimulates SQDG synthesis (32). Glyceraldehyde has been observed to inhibit SQDG synthesis, the proposed site of inhibition at the aldolase-catalyzed utilization of two three-carbon compounds to form an analog of fructose 1,6-bisphosphate (Sommerville and Benning, personal communication).

d). Cysteine was suggested as a precursor in *Euglena gracilis* var. *bacillaris* (49). In this system, the spatial separation of the sulfate assimilatory pathway, located in the mitochondria, and the SQDG synthetic capability, located in the chloroplast was utilized to show the transfer of a product of sulfate assimilation from the mitochondria to the chloroplast for incorporation into SQDG. Evidence indicated the transported precursor was either cysteine or sulfite (49) since both diluted sulfate incorporation into SQDG and were incorporated into SQDG by the chloroplasts. If cysteine were the precursor, the sulfur moiety must be oxidized before incorporation into SQDG. A report of *Chlorella pyrenoidosa* deficient in SQDG when grown on cysteine as the sole sulfur source (56) suggests this algae cannot oxidize cysteine to a form of sulfur that can be incorporated into SQDG. Cysteine was a precursor of SQDG in higher plants but was metabolized to sulfate prior to its incorporation into SQDG (40). In higher plant chloroplasts, unlabelled cysteine failed to dilute  $^{35}\text{SO}_4^{2-}$  incorporation into SQDG and labelled cysteine was not incorporated into SQDG (31).

e). Other reports also indicate sulfite can act as a precursor of SQDG. Sulfite and PAPS were compared as precursors of SQDG in a cell homogenate of *Chlamydomonas reinhardtii* (24). PAPS showed normal substrate kinetics ( $K_m$  25  $\mu\text{M}$ ) but the sulfite concentration curve at 200  $\mu\text{M}$  was higher than that of PAPS and showed no saturation. In higher plant chloroplasts, the addition of 100  $\mu\text{M}$  unlabelled sulfite decreased  $^{35}\text{SO}_4^{2-}$  incorporation into SQDG but was toxic in general (31). Addition of sulfite at 50  $\mu\text{M}$  or sulfite-generating compounds at 100  $\mu\text{M}$  greatly inhibited SQDG synthesis but only partially inhibited synthesis of other chloroform soluble sulfur compounds (34). Participation of sulfite has chemical precedent since sulfoquinovose can be chemically synthesized by the reaction of sulfite with quinovoseenide (38). If a comparable pathway were to exist in plants, the involvement of a six-carbon compound would then be implied (54, 62).

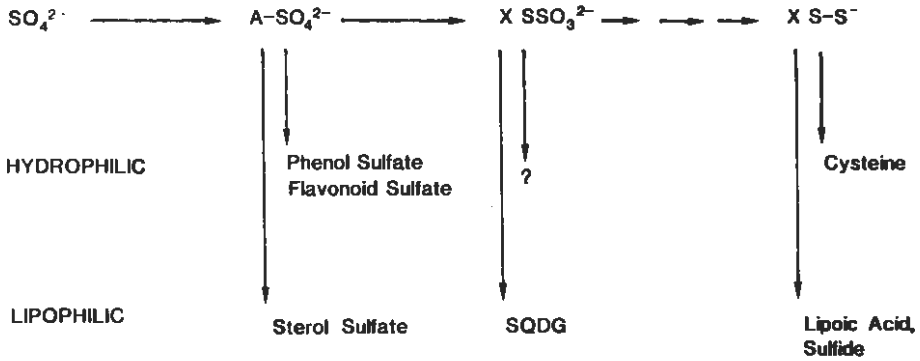

Fig. 1. Use of intermediates on the sulfate reduction pathway for the synthesis of lipophilic and hydrophilic compounds. Sulfate is activated to APS or PAPS ( $A-SO_4^{2-}$ ) which can be used to synthesize water-soluble or lipid-soluble compounds. Conversion to the carrier S-sulfonate intermediate is the first step of sulfate reduction, which can be the donor for sulfonates such as SQDG. The S-sulfide end-product is used in the formation of water-soluble compounds such as cysteine, but can also give rise to lipid-soluble compounds such as elemental sulfur, lipoic acid, PSC and DCS.

f). Demonstration that UDP-SQ is an intermediate would be a major advance. However, this requires either the chemical synthesis of UDP-SQ or the isolation of sufficient material from plants. The involvement of UDP-sulfoquinovose in SQDG synthesis is analogous to monogalactosyldiacylglycerol (MGDG) synthesis from UDP-galactose and diacylglycerol (DG) (41, 54). Unfortunately, no one has been able to synthesize UDP-SQ. The detection of UDP-SQ in *Scenedesmus* was encouraging (67), but this result remains unconfirmed.

The study of water soluble intermediates in SQDG synthesis might lead to the identification of reaction steps along the pathway. However, each intermediate of the sulfur reduction pathway can give rise to both lipid-soluble and water-soluble compounds (see Fig. 1). APS or PAPS can give rise to sulfated phenols and sulfated sterols. The postulated carrier sulfate can be hypothesized to give rise to SQDG via other water soluble intermediates. The carrier bearing reduced forms of sulfur can give rise to the lipophilic lipoic acid or water-soluble cysteine. The variation and complexity of these reactions calls for a stroke of luck in tracing the pathway of SQDG biosynthesis.

#### *The diacylglycerol moiety*

The diacylglycerol (DG) moiety of chloroplast glycerolipids arises by two different pathways (46,47) as exemplified by differences in the fatty acid composition of MGDG from various plant species (Fig. 2). In some species MGDG is characterized by the predominance 16:3 fatty acid at the *sn*-2 position and in others by the predominance of 18:3 at the *sn*-2 position (46). The 16:3 molecular species originates from DG synthesized in the chloroplast ('prokaryotic pathway') whereas the 18:3 species is synthesized from DG processed in the cytoplasm ('eukaryotic pathway') (47). These two pathways are not mutually exclusive. The contribution of each can be calculated in any plant species by determining the fatty acid composition of the isolated glycerolipids. Determination of the total fatty acid composition and that at



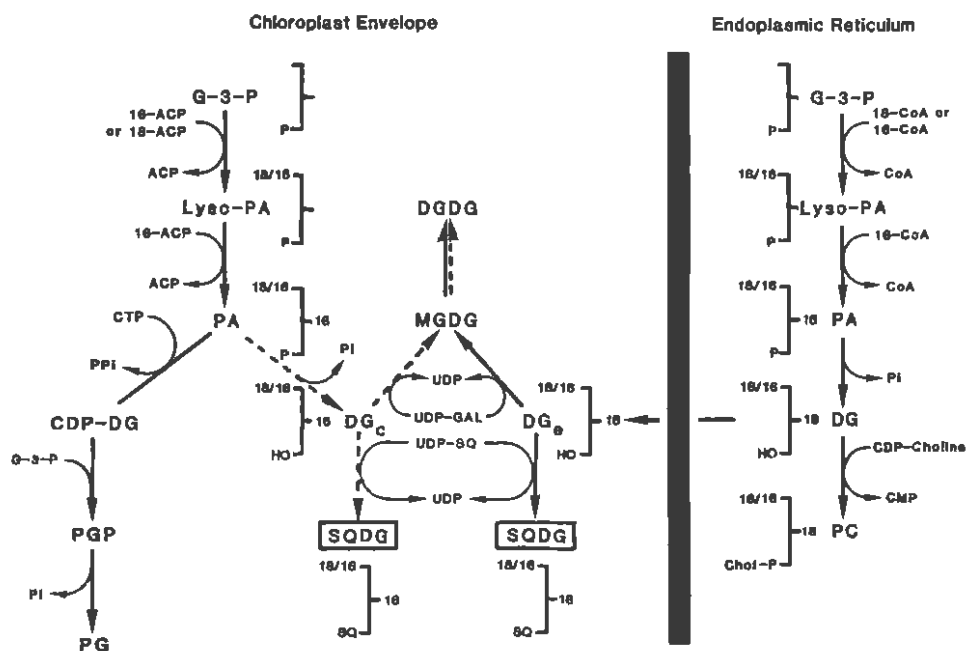

Fig. 2. Schematic of the origin of the DG moieties of chloroplastic glycerolipids. Solid lines delineate pathways active in both 16:3 and 18:3 plant species, where the DG is derived from the eukaryotic pathway in part in 16:3 plants and almost exclusively in 18:3 plants. Dashed lines indicate the additional pathway active in 16:3 plants.  $DG_C$  may arise from transported phospholipid or diacylglycerol species further processed in the envelope.

the *sn*-1 and *sn*-2 positions indicated SQDG is synthesized by both the prokaryotic and eukaryotic pathways (7, 26).

### Catabolism of sulfoquinovosyldiacylglycerol

After 1980, published work indicated compounds of the sulfoglycolytic sequence were involved in degradation of SQDG and the algal sulfolipids. This was partly due to the results of Lee and Benson (36) on degradation of  $^{35}\text{S}$ -sulfoquinovose indicating transfer of the label from SQ to sulfolactic acid, a key intermediary of the sulfoglycolytic sequence (54).

Degradation of SQDG proceeds stepwise (Fig. 3) beginning with deacylation of SQDG to the lysosulfolipid sulfoquinovosyl monoglyceride (SQMG) (62). Reacylation of SQMG to SQDG can occur at rates up to 1.5 nmol/mg chl·h with palmitoyl CoA (61). Deacylation of SQMG to sulfoquinovosyl glycerol (SQG) is irreversible (15, 61). The deacylation of SQDG to SQG in higher plants results in a differential turnover in the various fatty acid molecular species indicating specificity is for the fatty acid moiety, not the headgroup (8). Hence, a number of acylhydrolases can act on SQDG (23) but none reported are specific for SQDG. Bacteria, and to a lesser extent the enzymes of the mammalian pancreas and intestinal mucosa, can also deacylate SQDG to SQMG and on to SQG (15). SQG is sequentially degraded to SQ

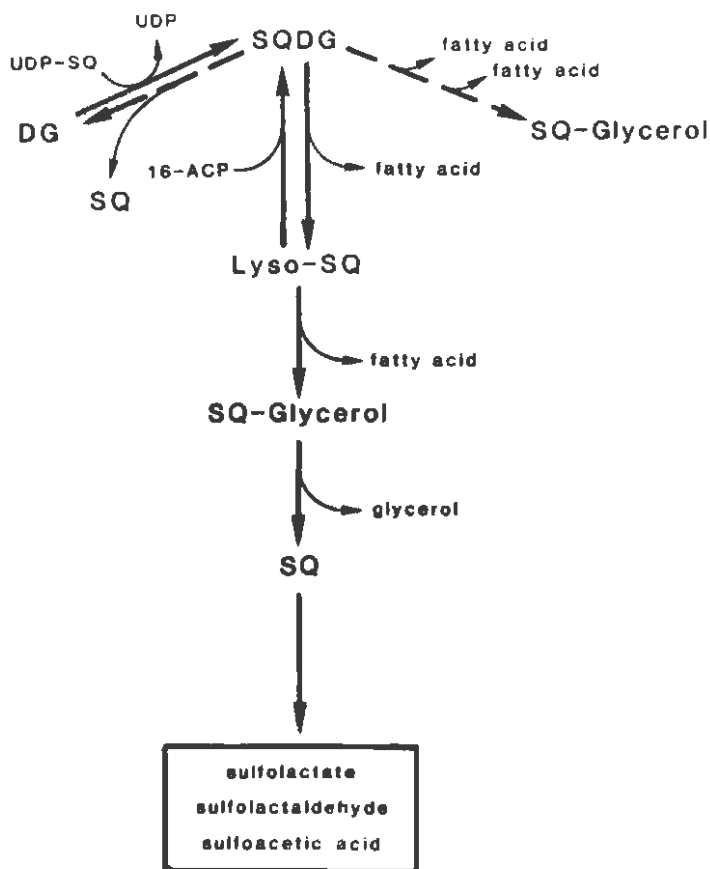

Fig. 3. Catabolism of SQDG. The major degradative sequence currently hypothesized is indicated by solid lines leading from SQDG through sulfolactate. Dashed lines represent other degradative pathways for which limited evidence is available. Synthesis of SQDG from DG and UDP-SQ and the reacylation of lyso-SQ to form SQDG are also indicated by solid lines.

then to sulfolactic acid and sulfate in *Medicago sativa* but in *Erythrina crista-galli* only sulfoacetic acid accumulates from SQG (36). Further work is needed to ascertain whether this main degradative pathway is fully operative in all plant species and whether any products are recycled into other sulfur compounds as in bacteria (60).

Others indicate SQ can be reincorporated into SQDG in groundnut leaf discs (14) and that degradation of SQG to SQ is not evident in *Phaseolus multiflorus* (8). This suggests the possible direct conversion of SQDG to DG and SQ in some plant species.

#### Other higher plant sulfolipids

Several other chloroform-soluble sulfur compounds, less polar than SQDG, are synthesized upon incubating isolated chloroplasts with radioactive sulfate, APS or PAPS (26, 31-34), a major component which was identified as elemental sulfur (27).

The metabolism of elemental sulfur by higher plants has been studied (37) although the biosynthetic origin has not been delineated. Others have indicated its importance in photosynthetic bacteria, algae and isolated chloroplasts (17,27,35). Current results indicate other compounds besides elemental sulfur are also present (34). These chloroform-soluble sulfur compounds most likely arise from reduced sulfur compounds and may lower  $^{35}\text{SO}_4^{2-}$  incorporation into SQDG by diverting APS away from SQDG synthesis.

Roots and hypocotyls of seedlings incubated with  $^{35}\text{SO}_4^{2-}$  contain at least two chloroform-soluble sulfur compounds, one chromatographing as SQDG and another behaving as a less polar compound migrating between SQDG and the solvent front (40). De Kok and co-workers have verified this for sugar beet roots (personal communication). The less polar spot can be further separated into three or more compounds, each behaving less polar than SQDG in polar lipid solvents, which chromatograph somewhat similar to the diatom sulfolipids (unpublished data, Klepinger-Sparace). These compounds need identification.

Cerebroside sulfatides (CS) were correlated with pollen compatibility in *Oenothera missouriensis* (11). The CS were chemically characterized, but the structures were not confirmed by IR or mass spectroscopy. This single report needs confirmation since pollen is easily contaminated by microbes and since the CS lack homo- $\delta$ -linolenate, the major fatty acid of other pollen ceramides.

### Algal sulfolipids

Several sulfolipids are present in algae besides SQDG. Haines (18) summarizes the structures and distribution of all algal sulfolipids known through 1984. However, a current detailed study extended through higher plants is needed. Three sulfolipids besides SQDG contain a C-S linkage, one unique to the *Phaeophyta*, (glucosyl-3',6'-disulfate)-6-sulfofucosyl diacylglycerol (SFDG) (39) and two found commonly in the *Bacillariophyta*, 1-deoxyceramide-1-sulfonic acid (DCS) and phosphatidylsulfocholine (PSC), more properly termed a sulfonium sulfolipid (29). The other algal sulfolipids are sulfatides. The sulfated sterol 24-methylene cholesterol sulfate (MCS) is currently restricted to the nonphotosynthetic diatoms of the *Bacillariophyta* (29). Kates (29) has recently reviewed the diatom sulfolipids. The alkyl sulfatides appear widely distributed among algae, but halogenated forms are restricted to the fresh water algal phyla with the exception of the *Euglenophyceae* (18). Haines (20) has reviewed sulfolipids in general and specifically the halogen sulfatides (19).

Studies of the glycerolipid SFDG are difficult since it contains both a sulfonate and a sulfate ester moiety and since mucilagenous material is extracted simultaneously (39). Verification of its identification and occurrence is needed.

The biosynthetic pathway to determine the mechanism of formation of the carbon-sulfur linkage for the ceramide DCS is currently under investigation (Kates, personal communication). Palmitoyl-CoA condenses with serine as in sphingosine biosynthesis, shown by using cycloserine to inhibit serine incorporation into DCS (29). Cysteine or cysteic acid sulfonate the product to form 1-deoxysphinganine-1-sulfonic acid, in a reaction analogous to known cystathione reactions (29). This compound is oxidized, acylated and the sphinganine form reduced to DCS. The capnoid sulfo-

lipids, capnine and N-acyl capnine, of the *Capnocytophaga* bacteria are very similar in structure to DSC differing only in the hydrocarbon chain (13). The taurine moiety originates from cysteic acid (60), formed either from oxidation of cysteine or from PAPS condensation with  $\alpha$ -aminoacrylic acid.

The glycerolipid PSC from diatoms was discovered co-migrating with phosphatidylcholine (PC) in chromatograms (28, 30). Sulfocholine is formed from methionine as shown elegantly by Kates (29) utilizing ( $^3\text{H}$ -methyl)- and ( $^{35}\text{S}$ )-labelled methionine. Dimethyl- $\beta$ -propiothetin is formed from methionine by deamination, then oxidative decarboxylation followed by methylation with S-adenosyl methionine. Further decarboxylation of dimethyl-propiothetin produces sulfocholine. This product is phosphorylated then converted to CDP-sulfocholine presumably by the same enzymes which accept the choline derivatives. The biosynthesis of PSC is the same as that of PC, the phosphocholine transferase accepting CDP-sulfocholine in place of CDP-choline (29). In the nonphotosynthetic diatom *Nitzschia alba* PSC replaces PC (30) but in other marine diatoms PSC is present in addition. In *Nitzschia alba*, the phosphocholine transferase has a higher affinity for sulfocholine than for the choline analog while in the photosynthetic diatoms the reverse is true (Kates, personal communication). PSC is very similar to PC in physical properties and its interactions with sterols (45), although the order parameters differ slightly in gel and liquid crystalline state (6, 57). The physical interactions of MCS with PSC compared to PC appear more stable as well (Kates, personal communication).

The enzymatic formation of sulfate ester bonds of all the sulfatides is thought to involve sulfate transferases similar to those in bacterial and animal systems. These reactions in higher plants have not received much attention nor been actively sought out. The desulfation of sulfatides, sulfated phenols, and sulfated flavonoids by commercial arylsulfatases suggest that plants contain a similar enzyme (2).

The alkyl sulfatides (ALS) consist of a hydrocarbon chain containing one or more sulfate-ester bonds (18). These compounds originate from long chain fatty acids, elongated from palmitate to C-22 through C-30. The long chain fatty alcohols are sulfated by a sulfate transferase which utilizes PAPS (19). A chloroperoxidase adds one or more chloro- or bromo- groups to positions 2 plus 11 through 17. Chlorinated derivatives are common in nature but brominated analogs are evident only with certain culture conditions (18). Molybdate inhibits the sulfation by affecting both sulfate uptake and activation (19). The sulfate transferase has not been purified nor completely characterized. The function(s) of these sulfatides, which are excreted by the algae, are not fully understood.

24-methylene cholesterol sulfate (MCS) is also found in the sea star *Asterius rubrius* and in mammals (29). In algae, MSC may function in detoxification, excretion and membrane stabilization as in animal systems (12). MCS is formed from the sulfation of preexisting methylene cholesterol by PAPS by a sulfate transferase (29), probably distinct from that of the ALS (1) but similar to the steroid sulfate transferase in mammalian tissues (48).

Sulfate transferase reactions are also implicated in the sulfation of flavonoid and phenolic compounds in algae and higher plants (2). Sulfated flavonoids are normally extracted into aqueous alcoholic solutions partitioned against organic solvents (21) but can partition into the organic phase under certain conditions, including the formation of ion-pairs (58). The flavonoid sulfate transferase is specific for PAPS, APS

will not substitute (59) nor will selenium analogs (42). The subcellular localization of the sulfate transferase(s) involved has yet to be determined although the sulfated flavonoids are thought associated with the vacuole and the sulfonation step believed a later step in their biosynthesis (Ibrahim, personal communication). The occurrence of these compounds or related sulfated phenolics in aquatic plant families is thought an adaptation to their aquatic habitat (21), but the distribution of sulfated flavonoids among all plants follows no distinguishable pattern (2).

Several unidentified compounds have been reported in algae (43, 44, 52, 53). These are mentioned in a separate review (41).

## Conclusions

In summary, the mechanism of synthesis of the sulfoquinovose headgroup of SQDG is still unknown but progress has been made. The results to date suggest either APS or sulfite is the sulfur donor of the sulfoquinovose headgroup. Whether these condense with a phosphorylated three-carbon or six-carbon compound or a nucleoside anhydrosugar derivative still remains to be tested. Determination of the carbon compounds involved in synthesis of the sulfoquinovose and verification of the involvement of UDP-SQ would represent major advances. Studies with sulfur deficient plants and with mutants of carbon or sulfur metabolism may be avenues of research worth pursuing. Compounds of the sulfoglycolytic sequence, once thought involved in SQDG biosynthesis, are now known to be involved in degradation of SQDG and the algal sulfolipids.

Sulfoacetate and sulfoacetaldehyde present in the chromatogram of *Chlorella ellipsoidea* extract (54), have now been reported as enzymatic or chemical degradation products of the diatom sulfolipids (29). Of special interest are studies implicating dimethyl- $\beta$ -propiothetin and cysteic acid in the biosynthesis of PSC and DCS and the finding of trace amounts of PSC in a *Euglena* sp. (29). Further work is necessary to determine the biosynthesis, degradation and distribution of all algal sulfolipids throughout the phyla of the algae and higher plants. Likewise a complete study of sulfation reactions is needed to elicit the mechanism and specificity of the enzymes involved.

Several unknown sulfolipids present in chloroplasts, roots, and algae are in need of identification. Although the chloroform-soluble  $^{35}\text{S}$ -sulfur compounds may reflect what chloroplasts are capable of, these compounds do not necessarily reflect compounds chloroplasts synthesize under the normal metabolic conditions. Their structure and response to various incubation conditions can aid in understanding not only SQDG synthesis but also whether or not inhibitory compounds are taken up by chloroplasts and are influencing sulfate metabolism (31, 34). These compounds may represent reactions which compete for sulfate and possibly other compounds such as acetate necessary for SQDG biosynthesis. In this respect these compounds are analogous to the algal sulfolipids and sulfonated flavonoids which likewise represent competing reactions that have helped in understanding aspects of SQDG metabolism especially the sulfoglycolytic products.

## Literature cited

1. Bannerjee, R. K. and Roy, A.B. 1967. The formation of cholesteryl sulphate by androstenedione sulphotransferase. *Biochim. Biophys. Acta* 137: 211-214.
2. Barron, D., Varin, L., Ibrahim, R.K., Harborne, J. and Williams, C. 1988. Sulphated flavonoids-An update. *Phytochem.* 27: 2375-2395.
3. Benson, A.A. 1963. The plant sulfolipid. *Adv. Lipid Res.* 1: 387-394.
4. Benson, A.A., Daniel, H. and Wiser, R. 1959. A sulfolipid in plants. *Proc. Nat. Acad. Sci. U.S.A.* 45: 1582-1587.
5. Benson, A.A. and Shibuya, I. 1961. Sulfo-carbohydrate metabolism. *Fed. Proc.* 20: 79.
6. Bishop, D.G., Sparace, S.A. and Mudd, J.B. 1985. Biosynthesis of sulfoquinovosyldiacylglycerol in higher plants: the origin of the diacylglycerol moiety. *Arch. Biochem. Biophys.* 240: 851-858.
7. Bisseret, P., Ito, S., Tremblay, P.-A., Volcani, B.E., Dessort, D. and Kates, M. 1984. Occurrence of phosphatidylsulfocholine, the sulfonium analog of phosphatidylcholine in some diatoms and algae. *Biochim. Biophys. Acta* 796: 320-327.
8. Burns, D.D., Galliard, T. and Harwood, J. 1977. Catabolism of sulfoquinovosyldiacylglycerol by an enzyme preparation from *Phaseolus multiflorus*. *Phytochem.* 16: 651-654.
9. Davies, W.H., Mercer, E.I. and Goodwin, T.W. 1966. Some observations on the biosynthesis of the plant sulfolipid by *Euglena gracilis*. *Biochem. J.* 98: 369-373.
10. Davies, H., Miyano, M., Mumma, R.O., Yagi, T., Lepage, M., Shibuya, I. and Benson, A.A. 1961. The plant sulfolipid-identification of 6-sulfoquinovose. *J. Amer. Chem. Soc.* 83: 1765-1766.
11. Delbart, C., Bris, B., Nouvelot, A. and Coustaut, D. 1983. Sulphatides and pollination in *Oenothera missouriensis*. *Phytochem.* 22: 869-874.
12. Farooqui, A.A. and Horrocks, L.A. 1985. On the role of sulfolipids in mammalian metabolism. *Mol. Cell. Biochem.* 66: 87-95.
13. Godchaux III, W. and Leadbetter, E.R. 1980. *Capnocytophaga* spp. contain sulfolipids that are novel in prokaryotes. *J. Bacteriol.* 144: 592-602.
14. Gupta, S.D. and Sastry, P.S. 1988. The biosynthesis of sulfoquinovosyldiacylglycerol: studies with groundnut (*Arachis hypogaea*) leaves. *Arch. Biochem. Biophys.* 260: 125-133.
15. Gupta, S.D. and Sastry, P.S. 1988. Metabolism of the plant sulfolipid- sulfoquinovosyldiacylglycerol: degradation in animal tissues. *Arch. Biochem. Biophys.* 259: 510-519.
16. Haas, R., Siebertz, H.P., Wrage, K. and Heinz, E. 1980. Localization of sulfolipid labeling within cells and chloroplasts. *Planta* 148: 238-244.
17. Hageage, G.J., Jr., Eanes, E.D. and Gherna, R. L. 1970. X-ray diffraction studies of the sulfur globules accumulated by *Chromatium* species. *J. Bacter.* 101: 464-469.
18. Haines, T.H. 1984. Microbial sulfolipids. In *CRC handbook of microbiology*, second edition, Laskin, A.I. and Lechevalier, H.A. eds., pp. 115-123, CRC Press, Boca Raton, Florida.
19. Haines, T.H. 1973. Halogen- and sulfur-containing lipids of *Ochromonas*. *Annu. Rev. Microbiol.* 27: 403-411.
20. Haines, T.H. 1973. Sulfolipids and halosulfolipids. In: *Lipids and biomembranes of eukaryotic microorganisms*, Erwin, J.A. ed., pp. 197-232, Academic Press, New York.
21. Harborne, J.B. 1975. Flavonoid sulphates: a new class of sulphur compounds in higher plants. *Phytochem.* 14: 1147-1155.
22. Harwood, J.L. 1975. Synthesis of sulfoquinovosyldiacylglycerol by higher plants. *Biochim. Biophys. Acta* 398: 224-230.
23. Harwood, J.L. 1981. Sulfolipids. In: *The biochemistry of plants*, Vol. 4, *Lipids: structure and function*, Stumpf, P.K. and Conn, E.E. eds., pp. 301-320, Academic Press, New York.
24. Hoppe, W. and Schwenn, J.D. 1981. *In vitro* biosynthesis of the plant sulfolipid: on the origin of the sulphonate group. *Z. Naturforsch.* 36c: 820-826.
25. Jocelyn, P.C. 1972. Chapter 3: Chemical reactions of thiols. In: *Biochemistry of the SH group*, pp. 63-88, Academic Press, New York.
26. Joyard, J., Blée, E. and Douce, R. 1986. Sulfolipid synthesis from  $^{35}\text{SO}_4^{2-}$  and  $[1-^{14}\text{C}]$  acetate in isolated intact spinach chloroplasts. *Biochim. Biophys. Acta* 879: 78-87.
27. Joyard, J., Forest, E., Blée, E. and Douce, R. 1988. Characterization of elemental sulfur in isolated intact spinach chloroplasts. *Plant Physiol.* 88: 961-964.
28. Kates, M. 1960. Chromatographic and radioisotopic investigations of the lipid components of runner bean leaves. *Biochim. Biophys. Acta* 41: 315-328.

29. Kates, M. 1989. The sulfolipids of diatoms. In: CRC marine biogenic lipids fats and oils, vol. 1, Ackmann, A., ed., CRC Press, Boca Raton, Florida (in press).
30. Kates, M. and Volcani, B.E. 1966. Lipid components of diatoms. *Biochim. Biophys. Acta* 116: 264-278.
31. Kleppinger-Sparace, K.F., Mudd, J.B. and Bishop, D.J. 1985. Biosynthesis of sulfoquinovosyldiacylglycerol in higher plants: the incorporation of  $^{35}\text{SO}_4$  by intact chloroplasts. *Arch. Biochem. Biophys.* 240: 859-865.
32. Kleppinger-Sparace, K.F. and Mudd, J.B. 1987. Biosynthesis of sulfoquinovosyldiacylglycerol in higher plants: the incorporation of  $^{35}\text{SO}_4$  by intact chloroplasts in darkness. *Plant Physiol.* 84: 682-687.
33. Kleppinger-Sparace, K.F. and Mudd, J.B. 1987. Biosynthesis of sulfoquinovosyldiacylglycerol in chloroplasts of higher plants. In: The proceedings of the seventh international plant lipid meetings, Stumpf, P.K., Ness, D. and Mudd, J.B., eds., pp. 309-311, Elsevier, New York.
34. Kleppinger-Sparace, K.F., Mudd, J.B. and Sparace, S.A. 1989. Biosynthesis of plant sulfolipids. In: This volume, pp. 205-208.
35. Krauss, K., Schäfer, W. and Schmidt, A. 1984. Formation of elemental sulfur by *Chlorella fusca* during growth on L-cysteine ethylester. *Plant Physiol.* 74: 176-182.
36. Lee, R.D. and Benson, A.A. 1972. The metabolism of glyceryl [ $^{35}\text{S}$ ]-sulfoquinovoside by the coral tree, *Erythrina crista-galli*, and alfalfa, *Medicago sativa*. *Biochim. Biophys. Acta* 261: 35-37.
37. Legris-Delaporte, S., Ferron, F., Landry, J. and Costes, C. 1987. Metabolism of elemental sulfur in wheat leaves consecutive to its foliar application. *Plant Physiol.* 85: 1026-1030.
38. Lehmann, J. and Benson, A.A. 1964. The plant sulfolipid. IX. Sulfosugar synthesis from methyl hexoseenides. *J. Am. Chem. Soc.* 86: 4469-4472.
39. Liem, P.Q. and Laur, M-H. 1976. Structures, teneurs et compositions des esters sulfuriques, phosphoriques des glycosyldiglycerides de trois fucacees. *Biochim.* 58: 1367-1380.
40. Mudd, J.B., Dezacks, R. and Smith, J. 1980. Studies on the biosynthesis of sulfoquinovosyldiacylglycerol in higher plants. In: Biogenesis and function of plant lipids, Mazliak, P., Benveniste, P., Costes, C., Douce, R. eds., pp. 57-66, Elsevier/North-Holland, Amsterdam.
41. Mudd, J.B. and Kleppinger-Sparace, K.F. 1987. Sulfolipids. In: The biochemistry of plants, Vol. 9, Lipids: structure and function, Stumpf, P.K. and Conn, E.E. eds., pp. 275-289, Academic Press, New York.
42. Nissen, P. and Benson, A.A. 1964. Absence of selenate esters and 'selenolipid' in plants. *Biochim. Biophys. Acta* 82: 400-402.
43. Opute, F.I. 1974. Lipid and fatty acid compositions of diatoms. *J. Expt. Bot.* 25: 823-835.
44. Opute, F.I. 1974. Physiological studies of the sulfolipids of diatoms. *J. Expt. Bot.* 25: 798-809.
45. Pugh, E.L., Bitmann, R., Fugler, L. and Kates, M. 1989. Comparison of steady-state fluorescence polarization and urea permeability of phosphatidylcholine and phosphatidylsulfocholine liposomes as a function of sterol structure. *Chem. Phys. Lipids* 50: 43-50.
46. Roughan, P.G. and Slack, C.R. 1982. Cellular organization of glycerolipid metabolism. *Annu. Rev. Plant Physiol.* 33: 97-132.
47. Roughan, P.G. and Slack, C.R. 1984. Glycerolipid synthesis in leaves. *TIBS* 9: 383-386.
48. Roy, A.B. and Trudinger, P.A. 1970. The Sulphotransferases. In: The biochemistry of inorganic compounds of sulfur, pp. 106-132, Cambridge University Press, London.
49. Saidha, T. and Schiff, J.A. 1989. The role of mitochondria in sulfolipid biosynthesis by *Euglena* chloroplasts. *Biochim. Biophys. Acta* 1001: 68-273.
50. Schiff, J.A. 1983. Reduction and other metabolic reactions of sulfate. In: Encyclopedia of plant physiology, New series, vol. 15, Pirson, A. and Zimmerman, M.H. eds., pp. 401-421, Springer-Verlag, New York.
51. Schmidt, A. 1979. Photosynthetic assimilation of sulfur compounds. In: Encyclopedia of plant physiology, New series, vol. 6, Gibbs, M. and Latzko, E. eds., pp. 481-496, Springer-Verlag, New York.
52. Shibuya, I. and Hase, E. 1965. Degradation and formation of sulfolipid occurring concurrently with de- and re-generation of chloroplasts in the cells of *Chlorella protothecoides*. *Plant Cell Physiol.* 6: 267-283.
53. Shibuya, I., Maruo, B. and Benson, A.A. 1965. Sulfolipid localization in lamellar lipoprotein. *Plant Physiol.* 40: 1251-1256.

54. Shibuya, I., Yagi, T. and Benson, A.A. 1963. Sulfonic acids in algae. In: Microalgae and photosynthetic bacteria, Japan Society Plant Physiology, pp. 627-636, University of Tokyo Press, Tokyo.
55. Siegel, L.M. 1975. Biochemistry of the sulfur cycle. In: Metabolism of sulfur compounds, Greenberg, D.M., ed., pp. 217-286, Academic Press, New York.
56. Sinensky, M.J. 1977. Specific deficit in the synthesis of 6-sulfoquinovosyl diglyceride in *Chlorella pyrenoidosa*. Bact. 129, 516-524.
57. Tremblay, P.-A. and Kates, M. 1981. Comparative physical studies of phosphatidylsulfocholine and phosphatidylcholine. Calorimetry, fluorescence polarization and electron paramagnetic resonance spectroscopy. Chemistry and Physics of Lipids 28: 307-322.
58. Varin, L., Barron, D. and Ibrahim, R.I. 1987. Enzymatic assay for flavonoid sulfotransferase. Anal. Biochem. 161: 176-180.
59. Varin, L. and Ibrahim, R.I. 1989. Purification and characterization of three flavonol-specific sulfotransferases from *Flaveria chloraefolia*. Plant Physiol. (in press).
60. White, R.H. 1986. Intermediates in the biosynthesis of coenzyme M (2-mercaptoethane sulfonic acid). Biochem. 25: 5304-5308.
61. Wolfersberger, M.G. and Pieringer, R.A. 1974. Metabolism of sulfoquinovosyl diglyceride in *Chlorella pyrenoidosa* by sulfoquinovosyl monoglyceride: fatty acyl CoA acyltransferase and sulfoquinovosyl glyceride: fatty acyl ester hydrolase pathways. J. Lipid Res. 15: 1-10.
62. Yagi, T. and Benson, A.A. 1962. Plant sulfolipid V. Lysosulfolipid formation. Biochim. Biophys. Acta 57: 601-603.
63. Zill, L.P. and Cheniaie, G.M. 1962. Lipid Metabolism. Annu. Rev. Plant Physiol. 13: 225-264.



# PHYTOCHELATINS, THE HEAVY METAL CHELATING PEPTIDES OF THE PLANT KINGDOM

Erwin Grill<sup>1</sup>, Ernst-Ludwig Winnacker<sup>2</sup> and Meinhart H. Zenk<sup>1</sup>

<sup>1</sup>*Lehrstuhl für Pharmazeutische Biologie, Universität München, Karlstrasse 29, D-8000 München 2, F.R.G.;* <sup>2</sup>*Laboratorium für Molekulare Biologie, Genzentrum, Am Klopferspitz, D-8033 Martinsried, F.R.G.*

## Contents

Introduction	89
Phytochelatin and homophytochelatin	90
Phytochelatin are ribosome-independently synthesized	91
What are the functions of phytochelatin?	92
Concluding remarks	93
Acknowledgements	94
Literature cited	94

## Introduction

Civilization has brought about a massive mobilization of heavy metals which are released into the biosphere. Ninety nine percent of the biomass on earth consists of plants (2). Plants are the organisms which are most heavily exposed to metal pollution through contaminated soil, water and air. Plants are in a dilemma. For healthy metabolism they require a supply of Zn, Cu, Se and Ni as trace nutrients. All these metals are, however, quite toxic when supplied in excess. Due to the geochemical activities of mankind, including agricultural practice (fertilization), plants are increasingly exposed to heavy metals such as Cd, Pb, Ag, Hg, etc, which are not micronutrients but rather toxic at small doses. As it has been stated recently: "The annual total toxicity of all the metals mobilized, in fact, exceeds the combined total toxicity of all the radioactive and organic wastes generated each year, as measured by the quantity of water needed to dilute such wastes to drinking water standard" (21). Plants which are exposed to toxic metals have to cope with this situation. They absorb metals and store them when supplied at non-lethal concentrations. Through plants, metals are passed into the human food chain (29). In the final member of this chain, the human being, these metals, especially Cd, accumulate and can exert adverse effects (14).

The question posed is how can plants tolerate the presence of 'unnatural' concentrations of heavy metals in the environment. In a recent article (31) possible mechanisms of metal tolerance in plants are summarized: a) metal-binding to plant cell walls,

b) reduced transport across the cell membrane, c) active efflux, d) compartmentalization, and e) chelation. The mechanism for which most information is available is chelation. Originally it was assumed that plants inactivate the heavy metals by complexing them with metallothioneins (25). Metallothioneins are low molecular weight, heat- and acid-stable proteins possessing a high cysteine content and a high affinity for heavy metal ions. They occur in vertebrates, in a few invertebrates and in some fungi such as yeast and *Neurospora* (17). Following the first report, several amino acid analyses of heavy metal binding 'proteins' from plants have been published which seemed to be in accordance with a 'plant metallothionein'(compiled in (7)).

### Phytochelatin and homophytochelatin

In search of a metal-activated promoter for plants we began with an investigation of the induction of 'metallothioneins' in higher plants. Plant cell cultures were chosen as the experimental material because of their high metabolic activity, the direct exposure of single cells to the metals (excluding transport problems as would be encountered with differentiated plants) and the absence of microorganisms which could interfere with the results. A fast growing cell suspension culture of *Rauvolfia serpentina* was exposed after 6 days of growth to 200  $\mu\text{M}$   $\text{CdSO}_4$  and the culture continued for another 4 days. The cells were harvested and extracted. The extracts of  $\text{Cd}^{2+}$  treated and non-treated cells were subjected to gel filtration chromatography and the metal and sulfhydryl groups containing fractions analyzed by atomic absorption spectrometry and Ellman's reagent, respectively (9). More than 90% of the total  $\text{Cd}^{2+}$  as well as the sulfhydryl groups were present in an intermediate peak with a surprisingly low molecular weight of about 3.5 kDa. Typically the level of this material was about 0.1% (w/w) of the dry weight of the cells. This material was isolated and further fractionated by HPLC. Five metal-free, but sulfhydryl groups containing peaks were identified. Amino acid analysis of the major peak yielded only L-cysteine, L-glutamic acid and glycine in a ratio of 4:4:1 unlike all other hitherto isolated metallothionein-like proteins from higher plants. A number of degradation steps proved this major compound to be  $(\gamma\text{-Glu-Cys})_4\text{-Gly}$ . The atomic constituents of this peptide were in perfect agreement with the theoretical requirement. The primary structure of the nonapeptide was confirmed by chemical synthesis. Sequence analysis of the other four peptides isolated by preparative HPLC yielded a series of peptides differing only in the number of  $(\gamma\text{-Glu-Cys})$  units. These peptides were not only induced by  $\text{Cd}^{2+}$  but also by  $\text{Zn}^{2+}$ ,  $\text{Cu}^{2+}$ ,  $\text{Ag}^+$ ,  $\text{Pb}^{2+}$  and  $\text{Hg}^{2+}$ . These peptides of the general formula  $(\gamma\text{-Glu-Cys})_n\text{-Gly}$  are the principal heavy metal binding components of plants. In addition, induction of metal binding peptides was observed in all the species tested from six out of the ten existing classes of the division *Phycophyta* (algae) (4). Furthermore, over 200 different plant species of the taxonomic division *Bryophyta*, *Pteridophyta* and *Spermatophyta* have been investigated for the ability to induce the peptides after  $\text{Cd}^{2+}$  exposure (5). Not a single plant or plant cell culture was found which did not synthesize poly $(\gamma\text{-Glu-Cys})$  peptides. However, in species of the order *Fabales*, mainly of the tribe *Fabaceae*, homologous molecules of the general structure  $(\gamma\text{-Glu-Cys})_n\text{-}\beta\text{-Ala}$  were identified (5, 8). Since the peptides occur in all plants thus far analyzed and since they chelate heavy metals,

they were named phytochelatin (PC) (9) and the  $\beta$ -alanine homologues, homo-phytochelatin (h-PC) (8).

From the fission yeast *Schizosaccharomyces pombe* two  $\text{Cd}^{2+}$  binding peptides identical to phytochelatin with two and three (Glu-Cys) units had already been isolated and sequenced (18, 20). The peptides were named cadystin B and A, respectively. Subsequent investigation of this organism by us (10) revealed that not only  $\text{PC}_2$  and  $\text{PC}_3$ , ( $\text{PC}_n$  corresponds to the phytochelatin with  $n$  ( $\gamma$ Glu-Cys) units), are formed under  $\text{Cd}^{2+}$  exposure but rather a set of peptides with up to 8 (Glu-Cys) units. The peptides in the fission yeast are identical to those of the higher plants. In addition, not only  $\text{Cd}^{2+}$  is able to induce these peptides but a whole range of ions of heavy metals such as Bi, As, Cu, Pb, Zn, Ag.

The primary structure of phytochelatin isolated from plant cells was independently determined and verified by triple quadrupole mass spectrometry (30). In plants, there appears to be no indication of the formation of metallothioneins. More than 60%, generally more than 90% of the  $\text{Cd}^{2+}$  ions which had entered the cell were associated with phytochelatin as demonstrated by gel filtration experiments (9, 11). Compared to controls, there was no increased metal-binding capacity in either the protein fraction ( $\geq 10$  kDa) or the low molecular weight ( $< 1$  kDa) fraction. A metallothionein induction in plants analogous to that observed in mammalian systems (17) would have been detected in these types of experiments. In addition, [ $\text{S}^{35}$ ]-cysteine feeding experiments to  $\text{Cd}^{2+}$  tolerant and sensitive tomato cell cultures did not reveal any major metal-induced cysteine containing protein band upon SDS-PAGE, excluding the presence of metallothioneins in plants (15).

The published amino acid compositions of putative metallothioneins isolated from plants (27, compiled (7)) most likely reflect analyses of partially purified phytochelatin. Thus, phytochelatin and not metallothioneins are the principal heavy metal-binding components of plants.

Recently one organism was found, the fungus *Candida glabrata*, which upon exposure to copper ions synthesizes two metallothionein-like polypeptides, and upon exposure to cadmium ions synthesizes the phytochelatin  $\text{PC}_2$  (19). This finding that one and the same organism contains both metal inactivating mechanisms, the one from plants as well as that from animals, may reflect lateral gene transfer in the division *Mycophyta* (fungi).

### Phytochelatin is ribosome-independently synthesized

One major point of interest is the formation of the phytochelatin molecules. Because of the isopeptidic linkage in the repetitive ( $\gamma$ -Glu-Cys) units these peptides cannot be ribosomally formed and, therefore, cannot be regarded as primary gene products (9). The phytochelatin may be viewed as linear polymers of the  $\gamma$ -Glu-Cys portion of glutathione. Careful kinetic analysis of phytochelatin formation both in *Rauvolfia* culture (11), maize (24) and *Schizosaccharomyces* (10) showed that phytochelatin were synthesized at the expense of glutathione. The direct involvement of this tripeptide has, however, not yet been proven. Indirect evidence is provided by the fact that buthionine sulfoximine, a specific inhibitor (6) of L-glutamate: L-cysteine  $\gamma$ -ligase (ADP-forming) [EC 6.3.2.2], strongly inhibits the formation of phytochelatin in

plant cultures (10, 11, 26, 28, 30). Phytochelatins are synthesized either directly from glutathione or from its biosynthetic precursor,  $\gamma$ -glutamylcysteine. The induction of the peptides was not prevented by cycloheximide (28) and no lag period of phytochelatin formation was observed (11) suggesting that the peptides are synthesized by constitutive enzyme(s). The clarification of the mechanism of formation of phytochelatins or homo-phytochelatins has to await discovery of the responsible enzymes. The regulatory mechanism by which phytochelatin biosynthesis is induced in the presence of heavy metal ions will be of special interest since even practical aspects can be derived out of this knowledge as mentioned below.

### What are the functions of phytochelatins?

The facts that heavy metal ions are predominantly complexed to phytochelatin within the plant cell and that the peptide formation is strongly induced by these ions, indicate a heavy metal-binding role for phytochelatins. Efficient sequestration of toxic metal ions reduces or prevents deleterious effects of the ions by physiological inactivation. Several evidences support the view of a detoxifying function of phytochelatins.

If phytochelatin synthesis was inhibited by buthionine sulfoximine which was not toxic to plant cells, the plant culture became more sensitive towards Ag ions (11). Similarly, cadmium resistant tomato cell lines when grown in the presence of this inhibitor lost their resistance and became metal sensitive (30). The lack of PC and/or glutathione synthesis obviously confers sensitivity of the cells towards these heavy metals. In addition, plant cells which were selected for tolerance against Cd ions revealed increased levels of phytochelatins (15, 16, 30). Comparison of the kinetics of metal-complex formation between metal sensitive and tolerant cultivars led to the suggestion that not the level, but rather the initial rate of formation confers tolerance (3, 23).

Phytochelatin synthesis appears to render plant cells, within specific limits, tolerant towards certain heavy metals. Phytochelatins were unequivocally identified in roots of *Acer pseudoplatanus* and *Silene cucubalus* plants growing in zinc-rich soil (28 g total zinc per kg dried soil) of a mine dump (12). Both plants, when collected from a metal uncontaminated stand located nearby, revealed no phytochelatins. Thus, these metal binding peptides are specifically induced in plants from heavy metal enriched ecosystems. This report of the occurrence of phytochelatins in the natural environment supports a role of phytochelatins in the heavy metal detoxification process in plants. We do not claim that the potential of phytochelatin synthesis is the cause for metal resistance in plants known as metal hyper-accumulators (1) which withstand extremely high metal concentrations in their natural habitat. We believe, however, that the phytochelatin system provides a mechanism by which plants can buffer the potential of heavy metal intoxication within certain limits.

The phytochelatin system could also balance the physiological availability of essential heavy metal ions in the plant cell and provide a mechanism for homeostasis of these ions. Metal-phytochelatin complexes of ions such as  $\text{Cu}^{2+}$  and  $\text{Zn}^{2+}$  possibly serve a dual purpose. Firstly, excess metal ions could be prevented from interfering with, for instance, sulfhydryl groups of proteins and other macromolecules and,

thus, be safely stored in the cytoplasm. Secondly, the metal ions could be transferred to newly synthesized apoenzymes which require Cu or Zn ions for catalytic activity in an equilibrium reaction between the metal binding site(s) of phytochelatin and the apoenzyme.

Nutrient solutions for plant cell culture contain low levels of the micronutrients Zn (2-40  $\mu\text{M}$ ) and Cu (0.1-1  $\mu\text{M}$ ). These concentrations are sufficient to induce phytochelatin. Transfer of cell cultures of various plant species from spent to fresh medium resulted in a 3-40 fold increase in phytochelatin (11, 13). Induction of the peptides was almost completely due to the zinc ions. Phytochelatin was not significantly formed if zinc and copper were omitted from the nutrient solutions for plant cell culture. At the end of the logarithmic growth phase the concentration of metal binding molecules started to decrease. No excretion of the phytochelatin into the spent medium was observed, compatible with the degradation of phytochelatin peptides after transfer of zinc ions to acceptors like apoforms of metalloenzymes and the vacuole system.

A third major role for the PC-type molecules has been postulated in the sulfur metabolism (30). It had been discovered that 1 mol of the Cd-binding peptide (Cd-BP1), in our terminology PC<sub>3</sub>, from the fungus *Schizosaccharomyces pombe* contains 1 mol of acid labile sulfide in the metal complex (20). This acid labile sulfide is also present in phytochelatin-metal complexes of photosynthesizing plants (4, 30). The suggestion has been made (30) that the heptapeptide PC<sub>3</sub> possesses the necessary requirement to act as the acceptor of sulfate, transferred by adenosine 5'-phosphosulfate sulfotransferase, for sulfate reduction in plants. This possibility is being critically discussed in this volume (see: Brunold). Certainly, however, the increased synthesis of phytochelatin in plants under heavy metal stress will lead to a strong demand of L-cysteine for the synthesis of these metal chelating molecules.

Indeed, corn seedlings exposed to Cd<sup>2+</sup> had elevated levels of both ATP-sulfurylase and adenosine 5'-phosphosulfate sulfotransferase (22). Regulation of sulfur metabolism in plants under heavy metal stress will be of considerable interest in the future. It is feasible that the phytochelatin molecules serve not only as a storage and transport form for metals but also for sulfide which is necessary for the biosynthesis of sulfur containing amino acids and coenzymes.

### Concluding remarks

Phytochelatin and homo-phytochelatin of the general formula  $(\gamma\text{-Glu-Cys})_n\text{Gly}$  and  $(\gamma\text{-Glu-Cys})_n\text{-}\beta\text{-Ala}$ , respectively, are the principal heavy metal binding components of the plant kingdom. *Phycophyta*, some *Mycophyta*, *Bryophyta*, *Pteridophyta* and *Spermatophyta*, all contain this metal ion complexing mechanism. Metallothioneins appear not to occur in plants (except for fungi). The inducible phytochelatin system provides a mechanism to buffer the physiological effects of heavy metal ions by forming a metal thiolate complex. The function of the peptides is, firstly, assigned to detoxification of heavy metals like Cd, Bi, As, Cu, Pb, Zn and Ag. Secondly, phytochelatin is probably involved in heavy metal ion homeostasis by providing a balanced intracellular concentration of essential heavy metals (Zn, Cu). Thirdly, they may play a role in sulfur metabolism, especially in sulfate reduction as well as in storing and transporting sulfide.

To fully understand the role of phytochelatins in plants much research has still to be devoted to the aspects of physiology and biochemistry of metal and sulfur metabolism. The enzymes responsible for the synthesis of phytochelatins and their genes are particularly important to understand the regulatory mechanisms.

In the long term, mankind will have to control heavy metal pollution in the environment. Until this goal is achieved, the human population is confronted with a man-induced mobilization of 5.7 million tons of toxic heavy metals (Cd, Cu, Hg, Pb, Zn) annually discharged into the biosphere with unknown health risks for future generations (21). A high quantity of these metals will reach terrestrial and aquatic plants. If the metal concentration is in a tolerable range, plants will respond to the heavy metal stress by phytochelatin synthesis. Nothing is known about the final deposition of these metals within the plant cells or organs, and no information exists on the fate of the PC molecules and the immobilized metals during decay of plant material. In order to prevent excessive amounts of the toxic metals from reaching man through the food chain, it is possible to consider genetically engineered food plants. Organ specific promoters for the genes synthesizing metal binding components could eventually lead to plants which specifically immobilize excess amounts of heavy metals at sites not used for consumption. For instance, vegetable plants could be envisaged which completely bind cadmium ions to phytochelatin molecules in the root system, so the upper, edible part of the plant remains uncontaminated (14). Even detoxification of metal contaminated soils should be possible by using transgenic plants. Thus, phytochelatins are not only fascinating from an academic point of view but may also provide some help to control a serious challenge to our environment.

### Acknowledgements

We thank Dr. T.M. Kutchan for linguistic help in preparing this manuscript. Research at Munich was supported by Bundesminister für Forschung und Technologie (Bonn) and Fonds der Chemischen Industrie.

### Literature cited

1. Brooks, R.R., Reeves, R.D., Morrison, R.S. and Malaisse, F. 1981. Bull. Soc. Roy. Bot. Belg. 113: 166-172.
2. Buschmann, C. and Grumbach, K. 1987. Physiologie der Photosynthese. Heidelberg: Springer Verlag.
3. Delhaize, E., Jackson, P.J., Lujan, L.D. and Robinson, N.J. 1989. Poly( $\gamma$ -glutamylcysteinyl)glycine synthesis in *Datura innoxia* and binding with cadmium. Plant Physiol. 89: 700-706.
4. Gekeler, W., Grill, E., Winnacker, E.-L. and Zenk, M.H. 1988. Algae sequester heavy metals via synthesis of phytochelatin complexes. Arch. Microbiol. 150: 197-202.
5. Gekeler, W., Grill, E., Winnacker, E.-L. and Zenk, M.H. 1989. Survey of the plant kingdom for the ability to bind heavy metals through phytochelatins. Z. Naturforsch. 44c: 361-369.
6. Griffith, O.W. and Meister, A. 1979. Potent and specific inhibition of glutathione synthesis by buthioneine sulfoximine (S-n-butyl homocysteine sulfoximine). J. Biol. Chem. 254: 7558-7560.
7. Grill, E. 1987. Phytochelatins, the heavy metal-complexing peptides of higher plants: characterization and sequence determination. In: Metallothionein II, Kägi, J.H.R., Kojima, Y. eds., Experientia Suppl. 52: 317-322. Basel: Birkhäuser Verlag.

8. Grill, E., Gekeler, W., Winnacker, E.-L. and Zenk, M.H. 1986. Homo-phytochelatin are heavy metal-binding peptides of homo-glutathione containing *Fabales*. FEBS Lett. 205: 47-50.
9. Grill, E., Winnacker, E.-L. and Zenk, M.H. 1985. Phytochelatin: the principal heavy-metal complexing peptides of higher plants. Science 230: 674-676.
10. Grill, E., Winnacker, E.-L. and Zenk, M.H. 1986. Synthesis of seven different homologous phytochelatin in metal-exposed *Schizosaccharomyces pombe*. FEBS Lett. 197: 115-120.
11. Grill, E., Winnacker, E.-L. and Zenk, M.H. 1987. Phytochelatin, a class of heavy metal-binding peptides from plants, are functionally analogous to metallothioneins. Proc. Natl. Acad. Sci. U.S.A. 84: 439-443.
12. Grill, E., Winnacker, E.-L. and Zenk, M.H. 1988. Occurrence of heavy metal binding phytochelatin in plants growing in a mining refuse area. Experientia 44: 539-540.
13. Grill, E., Thumann, J., Winnacker, E.-L. and Zenk, M.H. 1988. Induction of heavy metal-binding phytochelatin by inoculation of cell cultures in standard media. Plant Cell Reports 7: 375-378.
14. Hallenbeck, W.H. 1984. Human health effects of exposure to cadmium. Experientia 40: 136-142.
15. Huang, B., Hatch, E., Goldsbrough, P.B. 1987. Selection and characterization of cadmium tolerant cells in tomato. Plant Sci. 52: 211-221.
16. Jackson, P.J., Roth, E.J., McClure, P.R. and Naranjo, C.M. 1984. Selection, isolation and characterization of cadmium-resistant *Datura innoxia* suspension culture. Plant Physiol 75: 914-918.
17. Kägi, J.H.R. and Kojima, Y. 1987. Metallothionein II, Experientia Suppl. 52. Basel: Birkhäuser Verlag.
18. Kondo, N., Imai, K., Isobe, M., Goto, T., Murasugi, A., Wada-Nakagawa, C. and Hayashi, Y. 1984. Cadystin A and B, major unit peptides comprising cadmium-binding peptides induced in a fission yeast -separation, revision of structure and synthesis. Tetrahedron Lett. 25: 3869-3872.
19. Mehra, R.K., Tarbet, E.B., Gray, W.R. and Winge, D.R. 1988 Metal-specific synthesis of two metallothioneins and  $\gamma$ -glutamyl peptides in *Candida glabrata*. Proc. Natl. Acad. Sci. U.S.A. 85: 8815-8819.
20. Murasugi, A., Wada, C. and Hayashi, Y. 1983. Occurrence of acid-labile sulfide in cadmium-binding peptide I from fission yeast. J. Biochem. 93: 661-664.
21. Nriagu, J.O. and Pacyna, J.M. 1988. Quantitative assessment of worldwide contamination of air, water and soils by trace metals. Nature 333: 134-139.
22. Nussbaum, S., Schmutz, D. and Brunold, C. 1988. Regulation of assimilatory sulfate reduction by cadmium in *Zea mays* L. Plant Physiol. 88: 1407-1410.
23. Rauser, W.E. 1984. Copper-binding protein and copper tolerance in *Agrostis gigantea*. Plant Sci. Lett. 33: 239-247.
24. Rauser W.E. 1987. Changes in glutathione content of maize seedlings exposed to cadmium. Plant Sci. 51: 171-175.
25. Rauser, W.E. and Curvetto, N.R. 1980. Metallothionein occurs in roots of *Agrostis* tolerant to excess copper. Nature 287: 563-564.
26. Reese, R.N. and Wagner, G.J. 1987. Effects of buthioneine sulfoximine on Cd-binding peptide levels in suspension-cultured tobacco cells treated with Cd, Zn, or Cu. Plant Physiol. 84: 574-577.
27. Robinson, N.H. and Jackson, P.J. 1986. 'Metallothionein-like' metal complexes in angiosperms: their structure and function. Physiol. Plant. 67: 499-506.
28. Scheller, H.V., Huang, B., Hatch, E. and Goldsbrough, P.B. 1987. Phytochelatin synthesis and glutathione levels in response to heavy metals in tomato cells. Plant Physiol. 85: 1031-1035.
29. Sherlock, J.C. 1984. Cadmium in foods and the diet. Experientia 40: 152-156.
30. Steffens, J.C., Hunt, D.F. and Williams, B.G. 1986. Accumulation of non-protein heavy metal-binding polypeptides ( $\gamma$ -glutamyl-cysteinyl)<sub>n</sub>-glycine in selected cadmium-resistant tomato cells. J. Biol. Chem. 261: 13879-13882.
31. Tomsett, A.B. and Thurmann, D.A. 1988. Molecular biology of metal tolerances of plants. Plant, Cell and Environ. 11: 383-394.

# GLUCOSINOLATES - FUNDAMENTAL, ENVIRONMENTAL AND AGRICULTURAL ASPECTS

Ewald Schnug

*Institute for Plant Nutrition and Soil Science, Christian-Albrechts-University, Olshausenstrasse 40, D-2300 Kiel, F.R.G.*

## Contents

Introduction	97
Fundamental aspects of glucosinolates	98
Occurrence	98
– Determination	99
– Biosynthesis	99
– Enzymatic degradation	100
– Regulating factors	100
Environmental aspects of glucosinolates	101
– Biological interactions	101
– Sulfur balance	102
Agricultural aspects of glucosinolates	102
– Antinutritional effects	102
– Glucosinolates as sulfur storage in plants	102
Literature cited	103

## Introduction

Glucosinolates are sulfur containing compounds produced by the secondary metabolism of certain plant species with the general structure given in Fig. 1. Glucosinolates are generally hydrolyzed by the enzyme myrosinase, which is present in all glucosinolate containing plant parts. The degradation of glucosinolates results in so called 'mustard oils'. However, the term 'glucosinolates' conceals the fact that due to great variation in the chemical configuration of the side chains (Fig. 1: 'R') this group consists of quite different members. In cruciferous plants alone up to 27 different glucosinolates have been identified (5, 6). An overview of the composition of the total glucosinolate content of *Brassicaceae* is given in Fig. 2. Additional details concerning the characteristics of glucosinolate side chains are given by Larsen (39), Underhill (78) and Bjerg *et al.* (6).

This contribution will give a supplement to the already existing comprehensive reviews of Larsen (39) and Underhill (78) with special regard to new features in fundamental, environmental and agricultural aspects.



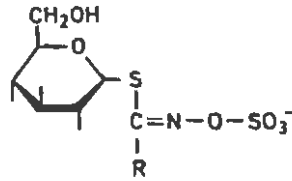

Fig. 1. Principal structure of a glucosinolate (R = rest cp. fig. 2).

structure	systematic name	trivial name	share of total content
alkenyl glucosinolates:			
			*
R = $-\text{CH}_2-\text{CHOH}-\text{CH}=\text{CH}_2$	(2-hydroxy-3-butenyl-)	progoitrin	ca. 65%
R = $-\text{CH}_2-\text{CH}_2-\text{CH}=\text{CH}_2$	(3-butenyl-)	gluconapin	ca. 25%
R = $-\text{CH}_2-\text{CH}_2-\text{CH}_2-\text{CH}=\text{CH}_2$	(4-pentenyl-)	glucobrassicinapin	ca. 8%
R = $-\text{CH}_2-\text{CHOH}-\text{CH}_2-\text{CH}=\text{CH}_2$	(2-hydroxy-4-pentyl-)	napoleiferin	ca. 2%
indol glucosinolates:			
R <sub>1</sub> = $\begin{array}{c} \diagup \quad \text{CH}_2- \\   \quad   \\ \diagdown \quad \diagup \\ \text{H} \end{array}$	R <sub>1</sub> = OH (4-hydroxy-3-indolyl-methyl-)	4-hydroxyglucobrassicin	ca. 4%
R = $\begin{array}{c}   \quad   \\ \diagdown \quad \diagup \\ \text{H} \end{array}$	R <sub>1</sub> = H (3-indolylmethyl)	glucobrassicin	ca. 1%
(remark: in 0-varieties with appr. 100 $\mu\text{mol/g}$ total content)			

Fig. 2. Main components of the glucosinolate fraction in seeds of *Brassica napus*.

### Fundamental aspects of glucosinolates

**Occurrence:** Until now 15 dicotyledonous taxa (*Akaniaceae*, *Bataceae*, *Brassicaceae*, *Bretschneideraceae*, *Capparaceae*, *Caricaceae*, *Euphorbiaceae*, *Gyrostemonaceae*, *Limnanthaceae*, *Moringaceae*, *Pentadiplandraceae*, *Resedaceae*, *Salvadoraceae*, *Tropaeolaceae*, *Tovariaceae*) with glucosinolate containing plants are described (15). All these families are on the same level of evolution without any striking differences in floral morphology (26). Thus the ability to synthesize glucosinolates seems to be the result of parallel evolution (64).

With view to agricultural interests and research work in the field of glucosinolates the most important species in the group of glucosinolate containing plants are *Brassica* species: these plants contain large amounts of highly valuable proteins and edible oils and can be divided into varieties with high (so called 'single low' or '0'-varieties; average content: 25 mol/g in vegetative tissue and 100  $\mu\text{mol/g}$  in seeds) and low (so called 'double low' or '00'-varieties; average content: 10  $\mu\text{mol/g}$  in vegetative tissue

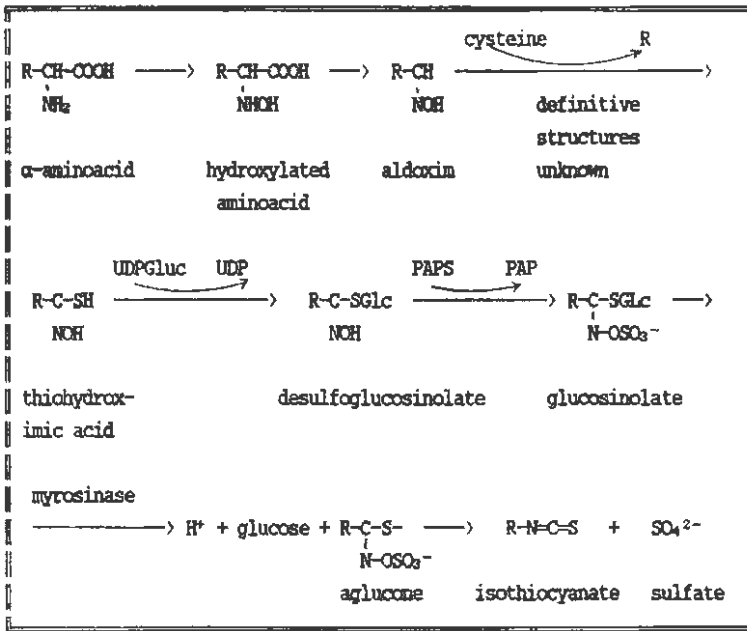

Fig. 3. Biosynthesis and enzymatic degradation of glucosinolates.

and 20 μmol/g in seeds). This allows comparative studies on factors influencing the glucosinolate metabolism.

**Determination:** A special problem in glucosinolate research is the comparability of analytical methods: recent ring tests on different methods (chromatographic, colorimetric, enzymatic and instrumental) have shown quite different results in identical samples (81). At the time high performance liquid chromatography (HPLC) for determination of individual glucosinolates (7, 83) and X-ray fluorescence spectroscopy for total glucosinolate analysis seem to be the most reliable methods (71, 73). For further informations about analytical details see Schnug and Haneklaus (71, 72) and Wathelet (83).

**Biosynthesis:** The present understanding in the biosynthesis of glucosinolates is briefly demonstrated in Fig. 3: Starting with an α-aminoacid (e.g. methionine in case of alkenyl-, thio-, sulfinyl- and sulfonylglucosinolates; tryptophane in case of indolglucosinolates) the first stable products in this pathway are hydroxylated amino acids, which are the precursors of aldoximes (36, 78).

In the next step the thiol group of cysteine is transferred to aldoxime synthesizing a thiohydroximic acid (79). However, the actual physiological knowledge can not explain important details of this step (6, 39, 52, 78).

Catalyzed by thiohydroximate-glucosyltransferase the addition of β-glucose leads to desulfoglucosinolates (47). After transfer of sulfate from PAPS by a sulfotransferase (21) glucosinolates derive. From this basic structure different glucosinolates

are derived by action of specific enzymes through elongation and hydroxylation of the side chains (3a, 20, 48, 80). Thus all alkenyl glucosinolates of rapeseed basically derive from methionine (Fig. 2).

In 00-varieties of *Brassica* species (all 00-cultivars originate from Bronowsky, a polish summer oilseed rape cultivar; 31) the low glucosinolate content appears to be induced by a metabolic block, before synthesis of 5-methylthiopentaldoxime (33; Underhill, pers. commun.). However, the chemical structure of the remaining intermediary products are unknown so far. The genetical repression in the glucosinolate content concerns alkenyl- and sulphinyl-, but not indolylglucosinolates (9, 45) though sulfate uptake, amino acid pattern and myrosinase activity are the same in both types (32, 33, 37, 40, 41, 68, 69).

Synthesis of glucosinolates takes part in all vegetative tissues, but the share of single glucosinolates may be different: in *Brassica* species the roots seem to contain large amounts of arylglucosinolates, whereas in leaves indolglucosinolates are predominant (9, 34, 76). Alkenylglucosinolates in *Brassica* seeds are synthesized in the pod walls and then transported into the seeds (40, 41). The mechanism of this transport is obviously specific for intact glucosinolates, so that intermediate products occurring in tissues of *Brassica* species with genetically low glucosinolate content can not enter seeds (69, 71). Thus pods of 00-varieties contain higher sulfur concentrations than pods of 0-varieties.

**Enzymatic degradation:** The thioglucosid-glucohydrolase myrosinase (E.C. 3.2.3.1) hydrolyzes the  $\beta$ -glucosidic link between glucose and reduced S (8, 25) splitting glucosinolates to glucose and an aglucone. The latter decomposes at weakly acidic conditions to sulfate, and by Lossen-rearrangement isothiocyanate (Fig. 3) results. Myrosinase always occurs in plant tissues, either isolated in idioblasts, stomatal guard cells or inside cells associated to cisterns of the endoplasmatic reticulum and mitochondria respectively, (29, 61). Whereas in idioblasts or stomatal guard cells myrosinase activity depends on mechanical injury of the plant tissue, in all other cases an endogenous regulation of myrosinase activity is possible (69, 78).

**Regulating factors:** The most important factor regulating the glucosinolate content in vegetative tissues and seeds obviously is the sulfur nutritional status of the plants (49, 56, 63, 68–70). Consequently very close linear relations between total sulfur concentration in younger fully differentiated leaves of *Brassica napus* (as an indicator of the nutritional status; X in mg/g total S) and glucosinolate content (Y in mol/g total glucosinolate) exist: younger leaves: 0-varieties:  $Y = 5.63X - 11.3$  ( $r = 0.929$ ), 00-varieties:  $Y = 0.94X - 0.70$  ( $r = 0.914$ ); seeds, 0-varieties:  $Y = 8.3X + 37$  ( $r = 0.747$ ), 00-varieties:  $Y = 1.2X + 12$  ( $r = 0.701$ ) (69).

A decreasing sulfur supply of the plants results in a decrease in free sulfate and glucosinolate concentrations and an increase in myrosinase activity (Fig. 4; see also 78). This implicates that the increase in myrosinase activity during sulfur stress has the function of a remobilization of sulfate sulfur from glucosinolates, because sulfate and isothiocyanates can be utilized as sulfur sources in the primary metabolism of the plants (43, 44). Apparently glucosinolates also function in storage of sulfur in cruciferous crops.

Sulfur nutritional status and a comparative short time of glucosinolate transport

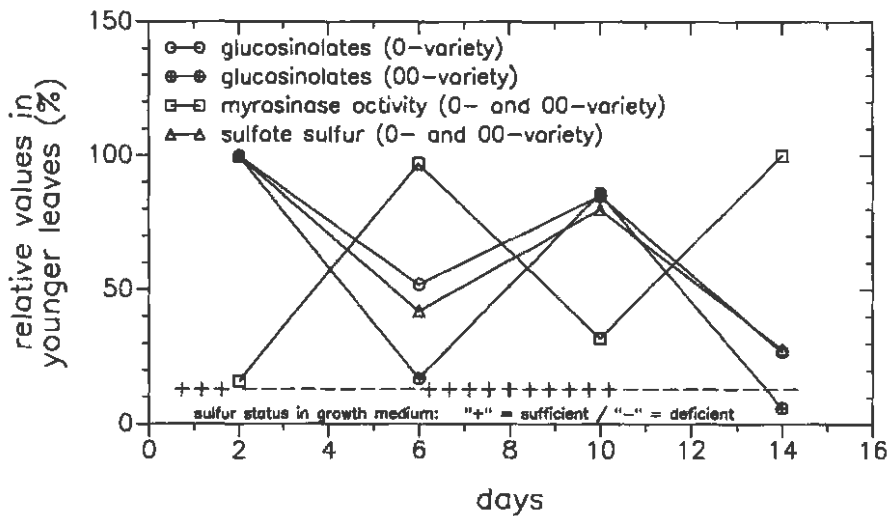

Fig. 4. Relative values of sulfate sulfur and total glucosinolate content and myrosinase activity in younger leaves of 0- and 00-oilseed rape as influenced by variations in sulfur supply in pot trials (69) (100% and [LSD 5%]: myrosinase activity = 6.8 [2.5]  $\mu\text{mol}/\text{min}$ .; total glucosinolate ( $\mu\text{mol}/\text{g}$ ) = 0-variety: 23.1 [4.1]; 00-variety: 10.4 [1.8];  $\text{SO}_4\text{-S}$  = 405 [110]  $\text{mg}/\text{kg}$ ).

into single seeds (6–8 days) (16, 70, 87) help to explain the environmental variabilities in the glucosinolate content in *Brassica* seeds as reported by numerous authors (35, 67, 77, 85, 86).

Another significant, but at the time unexplained phenomenon is the considerable lower boron content in vegetative parts of 00-varieties of *Brassica napus* (69).

### Environmental aspects of glucosinolates

**Biological interactions:** Glucosinolates are powerful tools for plants with regard to biological interactions. They can act as:

- attractants, stimulating the attention of insects (2, 3, 18, 53–55)
- repellents to insects and mammals (2, 3, 84) and
- insecticides (27, 38, 42), fungicides and antimicrobial protectors (10, 13, 14, 23, 51, 59, 60, 62, 74).

Inhibition of germination of plants can be induced by cruciferous crops sown before and seems to be the result of breakdown products of indolglucosinolates, which are related to derivatives of 3-indolyl acetic acid (1, 12, 25, 46, 48). The role of indolglucosinolates in plant hormone metabolism is, however, not fully understood (11, 48, 82).

The typical glucosinolate content in *Brassica napus* species also prevents wild animals from an excessive uptake of these plants. Therefore, one side effect of starting growing double low *Brassica* varieties in F.R.G. in 1986 was the damage of hares and roe deers due to an unphysiological high uptake of these plants (75). The symptoms of illness, however, have been caused by action of S-methyl-cysteine-sulfoxide (SMCO) (28, 57).

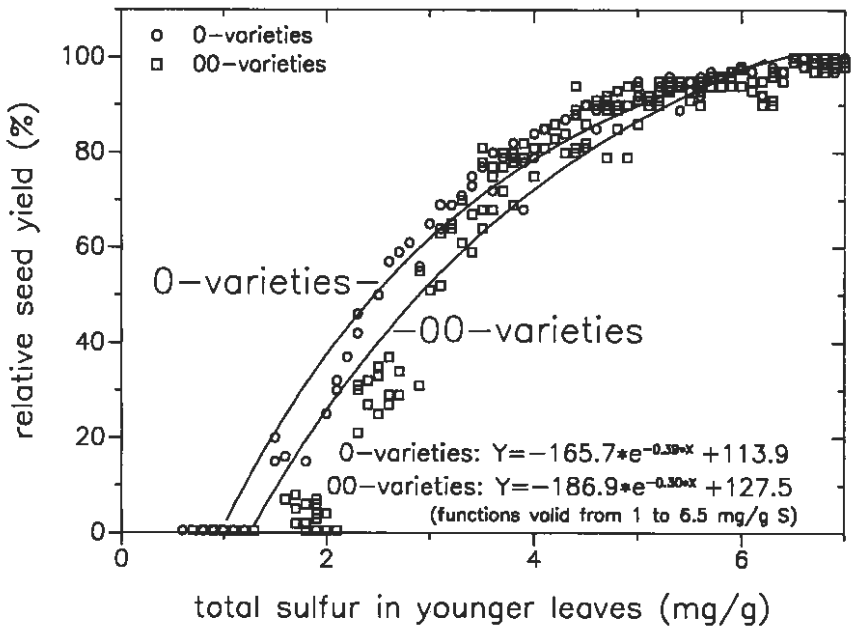

Fig. 5. Relations between the total sulfur content in younger fully differentiated leaves of 0- and 00-varieties of winter oilseed rape and the relative seed yield in pot trials (69).

**Sulfur balance:** Another environmental aspect of 00-varieties is the up to 50% decreased removal of sulfur by seeds in comparison with 0-cultivars, because sulfur is enriched in the pods (65, 69). The meaning of these changes in the sulfur balance (in the F.R.G. this difference is estimated to 7000 t/ha S) is not yet clear.

#### Agricultural aspects of glucosinolates

**Antinutritional effects:** Glucosinolates cause the flavour in spicy crops like mustard and radish (17) and moreover they are important inhibitors for an extensively use of rapeseed meal as a protein source (24). Typical side effects of feeding high glucosinolate rapeseeds are increased thyroid weight due to decomposition of progoitrine to vinyloxazolidine and toxic effects of nitriles on liver functions (4, 19, 22, 24, 33, 50, 58). Indolglucosinolates seem also to have certain effects on the formation of cancer (48).

**Glucosinolates as sulfur storage in plants:** In order to improve the use of rapeseed meal as a protein source cropping will be changed totally to new 00-varieties up to 1992 in the EC. However, from the viewpoint of sulfur nutrition the new varieties are obviously quite more sensitive to an insufficient sulfur supply than the old varieties with a high glucosinolate content: symptoms of severe sulfur deficiency are expected to occur in 0-varieties, when the total sulfur concentration in the leaves drops below 3 mg/g S, whereas deficiency symptoms in 00-varieties can be detected when the concentrations are lower than 3.5 mg/g S. Furthermore it can be stated, that the sensitivity to sulfur deficiency increases with decreasing glucosinolate contents (16, 70).

The reaction of yields to a decreasing sulfur supply is stronger in 00-varieties, too (Fig. 5), but the maximum yield of both oilseed rape cultivars will be reached at the same nutritional sulfur level. The role of glucosinolates in plant metabolism is therefore not only restricted to biological interactions (see above), but they act as a vital storage for sulfur. The remobilization of sulfur via increased myrosinase activity, however, is only possible from intact glucosinolates and not from intermediary products, which are enriched in varieties low in glucosinolates. A further reduction of glucosinolate levels by breeding may therefore strongly affect the vital power of those plants.

### Literature cited

1. Andersen, A.S. and Muir, R.M. 1966. Auxin activity of glucobrassicin. *Physiol. Plant.* 19: 1038-1048.
2. Beck, S.D. and Reese, J.C. 1976. Insect-plant interactions: nutrition and metabolism. *Recent Adv. Phytochem.* 10: 41-92.
3. Benn, M. 1977. Glucosinolates. *Pure Appl. Chem.* 49: 197-210.
- 3a. Bergmann, F. 1970. Die Glucosinolat-Biosynthese im Verlauf der Ontogenese von *Sinapis alba* L. *Z. Pflanzenphysiol.* 62: 362-375.
4. Bille, N., Eggum, B.O., Jacobsen, I., Olsen, O. and Sørensen, H. 1983. Antinutritional and toxic effects in rats of individual glucosinolates (+ - myrosinases) added to a standard diet. 1. Effects on protein utilization and organ weights. *Z. Tierphys. Tierernähr. Futtermittelkde.* 49: 195-210.
5. Bjerg, B., Eggum, B.O., Larsen, L.M. and Sørensen, H. 1987a. Acceptable concentrations of glucosinolates in double low oilseed rape and possibilities of further processing and plant breeding. *Proc. 7th Int. Rapeseed Congr., Poznan, Vol. 7:* 1619-1626.
6. Bjerg, B., Kachlicki, P.W., Larsen, L.M. and Sørensen, H. 1987b. Metabolism of glucosinolates. *Int. Rapeseed Congr., Poznan, Vol. 1.2:* 496-506.
7. Bjerg, B., Larsen, L.M. and Sørensen, H. 1987c. Reliability of analytical methods for quantitative determination of individual glucosinolates and total glucosinolate content in double low oilseed rape. *Proc. 7th Int. Rapeseed Congr., Poznan, Vol. 6:* 1330-1341.
8. Björkman, R. 1976. Properties and function of plant myrosinases. In: *The biology and chemistry of the Cruciferae*, pp. 191-206.
9. Buchner, R. 1988. Analyse und Biologie der Glucosinolate in Raps (*Brassica napus* L.). Diss. Agrarwiss. Fak., Gießen.
10. Buchwaldt, L., Nielsen, J.K. and Sørensen, H. 1985. Preliminary investigations of the effect of sinigrin on in vitro growth of three fungal pathogens of oilseed rape. In: *Advances in the production and utilization of cruciferous crops*, Sørensen, H. ed., pp. 260-267. Martinus Nijhoff/Dr. W. Jung Publ. Dordrecht.
11. Butcher, D.N., El-Tigani, S. and Ingram, D.S. 1974. The role of indole glucosinolates in the club root disease of the Cruciferae. *Physiol. Plant Pathol.* 4: 127-140.
12. Campbell, A.G. 1959. A germination inhibitor and root growth retarder in Chou Moellier (*Brassica oleracea* var.). *Nature* 183: 1263-1264.
13. Dornberger, K., Böckel, V., Heyer, J., Schönfeld, C., Tonew, M. and Tonew, E. 1975. Untersuchungen über die Isothiocyanate Erysolin und Sulforaphan aus *Cardaria draba* L.. *Pharmazie* 30(12): 792-796.
14. Drobnička, L., Zemanová, M., Nemeček, P., Antos, K., Kristian, P., Martvon, A. and Zavadská, E. 1968. Antifungal activity of isothiocyanates and related compounds. III. Derivatives of biphenyl, stilbene, azobenzene, and several polycondensed aromatic hydrocarbons. *Appl. Microbiol.* 582-587.
15. Ertlinger, M.G. 1987. Systematic distribution and biochemical properties of glucosinolates (mustard oil glucosides). XIV Int. Botanical Congr., Berlin, Germany, 5-26-1.
16. Evans, E. 1989. Glucosinolates and double low oilseed rape. In: *Double low oilseed rape for the 1990's*. Semundo Cambridge, pp. 79-83.
17. Fenwick, G.R., Heaney, R.K. and Mullin, W. J. 1983. Glucosinolates and their breakdown products in food and food plants. *CRC Critical Reviews in Food Sci. and Nutrition* 18 (2): 123-201.

18. Feeny, P. 1977. Defensive ecology of the Cruciferae. *Ann. Missouri Bot. Garden* 64: 221-234.
19. Gardrat, C. and Prevot, A. 1987. Dosage des glucosinolates dans les graines et les tourteaux de colza par voie enzymatique. *Revue Francaise des CORPS GRAS*, 34. Jahrg., No 10-11 (Etudes et Recherches No 2): 457-461.
20. Gland, A., Röbbelen, G. and Thies, W. 1981. Variation of alkenyl glucosinolates in seeds of *Brassica* species. *Z. Pflanzenzüchtg.* 87: 96-110.
21. Glendening, T.M. and Poulton, J.E. 1988. Glucosinolate biosynthesis sulfation of desulfobenzyl-glucosinolate by cell-free extracts of cress (*Lepidium sativum* L.) seedlings. *Plant Physiol.* 86: 319-321.
22. Greer, M.A. 1962. The natural occurrence of goitrogenic agents. *Recent Progr. Hormone Res.* 18: 187-219.
23. Hammond, K. and Lewis, B.G. 1987. Variation in stem infections caused by aggressive and non-aggressive isolates of *Leptosphaeria maculans* in *Brassica napus* var. *oleifera*. *Plant Pathol.* 36: 53-65.
24. Henkel, H. 1988. Double-low rapemeal and rapeseed in feed rations for pigs and poultry in the Federal Republic of Germany. *Proc. Int. Double Low Rapeseed Forum*, London, NIAB Cambridge, 51-54.
25. Hoffmann, F. 1978. Senföle. *Chemie in unserer Zeit* 6, 182-188.
26. Hofmann, U. 1987. Floral morphology of the glucosinolate producing plants. XIV Int. Botanical Congr., Berlin, Germany, 5-26-3.
27. Holm, S. N., Rahman, M.H., Stølen, O. and Sørensen, H. 1985. Studies on pollination requirements in rapeseed (*Brassica campestris*). In: *Advances in the production and utilization of cruciferous crops*; Sørensen, H. ed. pp. 245-253, Martinus Nijhoff/Dr. W. Junk, Dordrecht.
28. Johnston, T.D. and Godsen, A.F. 1975. Thiocyanate in forage kale (*Brassica oleracea* L.). *Euphytica* 24: 233-235.
29. Joergensen, L.B. 1987. Myrosin cells and other structural characteristics of glucosinolate plants. XIV Int. Botanical Congr., Berlin, Germany, 5-26-2.
30. Josefsson, E. 1975. Influence of glucosinolates and high-molecular factors on the nutritional value of low-glucosinolate rapeseed meal. *J.Sci. Food Agric.* 26: 1299-1310.
31. Josefsson, E. and Appelqvist, L.-A. 1968. Glucosinolates in seed of rape and turnip rape as affected by variety and environment. *J. Sci. Food Agric.* 19: 564-570.
32. Josefsson, E. 1971. Studies of the biochemical background to differences in glucosinolate content in *Brassica napus* L.. II. Administration of some sulphur-35 and carbon-14 compounds and localization of metabolic blocks. *Physiol. Plant.* 24: 161-175.
33. Josefsson, E. 1973. Studies of the biochemical background to differences in glucosinolate content in *Brassica napus* L.. III. Further studies to localize metabolic blocks. *Physiol. Plant.* 29: 28-32.
34. Jürges, K. 1982. Möglichkeiten einer Auslese auf Glucosinolat-Armut in der Grünmasse von *Brassica napus* und *B. campestris*. *Z. Pflanzenzüchtg.* 89: 74-87.
35. Kimber, D. 1988. Glucosinolate levels obtained in 1987 in the UK. *Proc. double low rapeseed forum*, London, NIAB Cambridge, 31-36.
36. Kindl, H. and Underhill, E.W. 1968. Biosynthesis of mustard oil glucosides: N-hydroxyphenylalanine, a precursor of glucotropaeolin and a substrate for the enzymatic and nonenzymatic formation of phenylacetaldehyde oxime. *Phytochem.* 7: 745-756.
37. Krzymanski, J. 1970. Genetyczne mozliwosci ulepszenia skladu chemicznego nasion rzepsku ozimego. *Hodowla roslin aklimatyzacja inasiennictwo* 14: 95-133.
38. Larsen, L.M., Nielsen, J.K., Plöger, A. and Sørensen, H. 1985. Responses of some beetle species to varieties of oilseed rape and to pure glucosinolates. In: *Advances in the production and utilization of cruciferous crops*, Sørensen, H. ed. pp. 230-244, Martinus Nijhoff/Dr. W. Junk, Dordrecht.
39. Larsen, P.O. 1981. Glucosinolates. In: *The biochemistry of plants* 7: 501-525.
40. Lein, K.-A. 1972a. Genetische und physiologische Untersuchungen zur Bildung von Glucosinolaten in Rapssamen: Lokalisierung des Hauptbiosyntheseortes durch Pfropfungen. *Z. Pflanzenphysiol.* 67: 333-342.
41. Lein, K.-A. 1972b. Genetische und physiologische Untersuchungen zur Bildung von Glucosinolaten in Rapssamen. I. Zur Vererbung der Glucosinolatarmut. *Z. Pflanzenzüchtg* 65: 243-254.
42. Lichtenstein, E.P., Morgan, D.G. and Mueller, C.H. 1964. Naturally occurring insecticides in cruciferous crops. *J. Agric. Food Chem.* 12: 158-161.
43. Machev, N.P. and Schraudolf, H. 1977. Biochemical relation between thiocyanide assimilation and indole-glucosinolate biosynthesis in *Sinapis Alba* L. *Proc. sec. int. symp. on plant growth regulators*, pp. 110-116.
44. Machev, N.P. and Schraudolf, H. 1978. Thiocyanate as predecessor of asparagine in *Sinapis alba* L. *Plant Physiol. (Bulgaria)* 4: 26-33.

45. Marquard, R. and Schlesinger, V. 1985. Methodische Untersuchungen zur Glucosinolatbestimmung bei Raps. *Fette Seifen Anstrichmittel* 87: 471-476.
46. Mason-Sedun, W., Jessop, R.S. and Lovett, J.V. 1986. Differential phytotoxicity among species cultivars of the genus *Brassica* to wheat. I. Laboratory and field screening of species. *Plant and Soil*, 93: 3-16.
47. Matsuo, M. and Underhill, E.W. 1971. Purification and properties of a UDP glucose: thiohydroximate glucosyltransferase from higher plants. *Phytochem.* 10: 2279-2286.
48. McDanell, R., McLean, A.E.M., Hanley, A.B., Heaney, R.K. and Fenwick, G.R. 1988. Chemical and biological properties of indole glucosinolates (glucobrassicins): A review. *Food Chem. Toxic.* 26: 59-70.
49. Merrien, A. and Pouzet, A. 1989. La fertilisation soufre. In: *Cahier technique colza agronomie*. CETIOM Paris France.
50. Michailovskij, N., Sedlak, J., Justic, M. and Buzina, R. 1969. Goitrogenic substances of kale and their possible relations to the endemic goitre on the island of Krk (Yugoslavia). *Endocrinologia Experimentalis* 3: 65-72.
51. Mithen, R.F., Lewis, B.G. and Fenwick, G.R. 1986. In vitro activity of glucosinolates and their products against *Leptosphaeria maculans*. *Trans. Br. Mycol. Soc.* 87: 433-440.
52. Møller, P., Rahman, M.H., Stlen, O. and Sørensen, H. 1985. Heredity of fatty acids and glucosinolates in oilseed rape. Possibilities for improvement of rape adapted for the growth conditions in tropical Asia. In: *Advances in the production and utilization of cruciferous crops*, Sørensen, H. ed. pp. 286-300, Martinus Nijhoff/Dr. W. Junk, Dordrecht.
53. Nielsen, J.K. 1977. Host plant relationships of *Phyllotreta nemorum* L. (Coleoptera: Chrysomelidae). *Z. Angew. Entomologie* 84: 396-407.
54. Nielsen, J.K. 1978. Host plant discrimination within Cruciferae: Feeding responses to four leaf beetles (Coleoptera: Chrysomelidae) to glucosinolates, cucurbitacins and cardenolides. *Entomologia Exp. & Appl.* 24: 41-54.
55. Nielsen, J.K., Dalgaard, L., Larsen, L.M. and Sørensen, H. 1979. Host plant selection of the horse-radish flea beetle *Phyllotreta armoraciae* (Coleoptera: Chrysomelidae): Feeding responses to glucosinolates from several crucifers. *Entomologia Exp. & Appl.* 25: 227-239.
56. Nutall, W.F., Ukrainetz, H., Stewart, J.W.B. and Spurr, D.T. 1987. The effect of nitrogen, sulphur and boron on yield and quality of rapeseed (*Brassica napus* L. and *Brassica campestris* L.). *Can. J. Soil Sci.* 67: 545-559.
57. Onderschenka, K., Tataruch, F., Steinbeck, T., Klasek, E., Vodnansky, M. and Wagner, J. 1987. Investigations on the deer-losses caused by rape-intake. *Wiener Tierärztliche Monatsschrift* 74: 369-377.
58. Papas, A., Ingalls, J.R. and Campbell, L.D. 1979. Studies on the effects of rapeseed meal on thyroid status of cattle, glucosinolate and iodine content of milk and other parameters. *J. Nutrition* 109: 1129-1139.
59. Pawlowski, S.H., Riegert, P.W. and Krzymanski, J. 1968. Use of grasshoppers in bioassay of thioglucosides in rapeseed (*Brassica napus*). *Nature* 220: 174-175.
60. Peterka, S. and Schlösser, E. 1988. In vitro Aktivität von Glucosinolaten gegen *Phoma lingam* (Tode) Desm. und *Sclerotinia sclerotiorum* (Lib) de Bary und ihre Bedeutung für die Krankheitsresistenz. *Vortr. Pflanzenzüchtg.* 13: 169-177.
61. Pihakaski, K. and Iversen, T.-H. 1976. Myrosinase in Brassicaceae I. Localization of myrosinase in cell fractions of roots of *Sinapis alba* L. *J. Exp. Bot.* 27: 242-258.
62. Rada, B., Hanuskovska, T., Drobnica, L. and Nemeč, P. 1971. Inhibition of virus multiplication by selected isothiocyanates. *Acta Virol.* 15: 329-332.
63. Ramans, M. 1989. Double low oilseed rape in the UK ex harvest 1988. In: *Double low oilseed rape for the 1990's*. Semundo Cambridge, pp. 101-122.
64. Rodman, J. 1987. Phenetic and cladistic studies of plants producing glucosinolates and myrosinase. XIV Int. Botanical Congr., Berlin, Germany, 5-26-5.
65. Saalbach, E. and Aigner, H. 1987. Über den Schwefelbedarf von Winterrapsorten. *Landwirtsch. Forsch.* 40: 1-7.
66. Sang, J.P. 1986. Glucosinolate content of flower buds and vegetative tissues of *Brassica napus* cv. Marnoo. *Eucarpia Cruciferae Newsletter* 11: 130-131.
67. Sang, J.P., Bluett, B.R., Elliott, B.R. and Truscott, J.W. 1986. Effect of time of sowing on oil content, erucic acid and glucosinolate contents in rapeseed (*Brassica napus* L. cv. Marnoo). *Austr. J. Exp. Agric.* 26: 607-611.



68. Schnug, E. 1987. Response of crop yield and quality to fertilization with elemental sulfur in Northern Germany. Proc. Symp. Int. Le Soufre Elementaire en Agriculture, Nice France, Vol. 2: 553-561.
69. Schnug, E. 1988. Quantitative und qualitative Aspekte der Diagnose und Therapie der Schwefelversorgung von Raps (*Brassica napus* L.) unter besonderer Berücksichtigung glucosinolatärmer Sorten. Habilitationsschrift Agrarwiss. Fak. der Christian-Albrechts-Universität zu Kiel.
70. Schnug, E. 1989. Double low oilseed rape in West Germany: sulphur nutrition and glucosinolate levels. In: Production and protection of oilseed rape and other brassica crops, Aspects of Applied Biology 23, (in press).
71. Schnug, E. and Haneklaus, S. 1988. The sulphur concentration as a standard for the total glucosinolate content of rapeseed and meal and its determination by X-ray fluorescence spectroscopy (X-RF method). J.Sci. Food Agric. 45: 243-254.
72. Schnug, E. and Haneklaus, S. 1989. A systematic study on factors influencing the determination of the total glucosinolate content in rapeseed by the X-RF method. Fat Sci. Techn. (in press).
73. Schnug, E., Haneklaus, S. and Wathelet, J.P. 1989. Experiences with the X-RF method for the determination of the total glucosinolate content in rapeseed. GCIRC-Bulletin (in press).
74. Schoenbeck, F.E. and Schloesser, E. 1976. Preformed substances as potential protectants. In: Physiological plant pathology, Heitefuß, R. and Williams, P.H. eds. pp. 653-678, Springer, Berlin, Heidelberg, New York.
75. Seifert, H.S.H. and Röbbelen, G. 1988. Production of 00-rapeseed varieties and its effect on wild life. Double low rapeseed forum, London, NIAB Cambridge, 62-65.
76. Stephani, V. 1985. Selektion auf Gehalt und Zusammensetzung der Glucosinolate in der Grünmasse von Raps (*Brassica napus* L.). Diss. Agrarwiss. Fak., Göttingen.
77. Taupeau, V. 1989. Caracterisation de facteurs de variabilite de la teneur en glucosinolates des graines de colza oleagineux (*Brassica napus* L. var. oleifera Metz.): enquete sur une variete a faible teneur. Ministere de l'Agriculture E.N.I.T.A.H. Angers France.
78. Underhill, E.W. 1980. Glucosinolates. In: Encyclopedia of plant physiology, New series, vol. 8, Secondary plant products, pp. 493-511, Springer-Verlag, Berlin.
79. Underhill, E.W. and Wetter, L.A. 1969. Biosynthesis of mustard oil glucosides: sodium phenylacetothiohydroximate and desulfobenzylglucosinolate, precursors of benzylglucosinolate in *Tropaeolum majus* L. Plant Physiol. 44: 584-590.
80. Underhill, E. and Wetter, L.R. 1973. Biosynthesis of glucosinolates. Biochem. Soc. Symp. 38: 303-326.
81. Wagstaffe, P. 1989. Determination of total glucosinolate in rapeseed - activities of BCR programme. Paper presented at expert meeting on double low oilseed rape BCR Brussels 21th April 1989.
82. Wall, M.E., Taylor, H., Perera, P. and Wani, M.C. 1988. Indoles in edible members of the Cruciferae. J. Natural Products 51: 129-135.
83. Wathelet, J.-P. 1986. Glucosinolates in rapeseeds: analytical aspects. Martinus Nijhoff Publishers, Dordrecht.
84. Zobelt, U., Daniel, P. and Marquard, R. 1986. Vergleichende Untersuchungen über Glucosinolatgehalte in der Grünmasse von Raps und Rübsen ihre Auswirkungen auf das Fressverhalten von Schafen. VDLUFA- Schriftenreihe 20: 561-571.
85. Zúkalová, H., Vasák, J. and Fabry, A. 1985. Dynamik der qualitativen Charakteristika der 00-Typen des Winterrapses. Rostlinna Vyroba 31: 685-692.
86. Zúkalová, H., Vasák, J. and Fabry, A. 1986. Problematik der Bildung der Glucosinolate im Laufe der Samenreife des Winterrapses Rostlinna Vyroba 32: 971-980.
87. Zúkalová, H. and Vlazný, K. 1987. Production of glucosinolates during winter rape seed ripening and the stability of their content in glucosinolate-free varieties in the course of cultivation. Int. rapeseed Congr., Poznan, vol. 1.2: 507-516.

## DISCUSSION SECTION 2

The discussion of the session 'Metabolism of Sulfur into Organic Sulfur Compounds' concentrated mainly on 4 topics, *i.e.* the natural role of glutathione-S-transferase, the compartmentation of glutathione, the possible dependency of the root on sulfur reduced in the leaves, and the chances for creating cereals with sulfur-rich storage proteins by genetic engineering.

In animal cells it is assumed that the natural function of glutathione-S-transferases is to detoxify aldehydes produced during the breakdown of lipids by oxygen radicals. Such a function of glutathione-S-transferases has so far not been reported for the plant enzymes. In plants enzymatic conjugation of aldehydes with glutathione appears to be unlikely, as numerous secondary products that can accumulate up to 10% of the plants' weight are aldehydates, but glutathione-conjugates of these compounds have never been found. Apparently these compounds are stored in the vacuole. However, there is evidence that plant glutathione-S-transferases possess hydroperoxidase activity; this activity may be the natural function of glutathione-S-transferases in plants.

Whereas high amounts of phytochelatins have been found in the vacuole, glutathione has not been demonstrated in this organelle. The observation that the glutathione content of leaves can be rapidly increased in the presence of excess sulfur may be an indication of a vacuolar glutathione pool rapidly exchanged with the cytoplasm. Still, glutathione transport at the chloroplast membrane is also uncertain. In pea it appears that isolated chloroplasts do not take up glutathione, but cysteine; there are some indications for an efflux of glutathione from isolated chloroplasts, but this has to be proven by future experiments. We know that between 40 and 70% of the glutathione in green tissue is located in the chloroplast, but the subcellular distribution of the remaining 60 to 30% is unknown.

There are several observations indicating that glutathione synthesized in the leaves is used as a source of reduced sulfur in the roots. On the other hand, both leaves and roots are capable to reduce sulfate and to incorporate it into cysteine and glutathione. The observation that radiolabel of glutathione fed to the leaves is incorporated into the protein of the roots does not prove that the root is dependent on reduced sulfur produced in the leaves. The glutathione transported to the roots may enter a pool of glutathione synthesized by the roots; the turnover of this pool will then generate radiolabeled cysteine that can be used for protein synthesis. The major problem is that from the experiments published the actual amount of glutathione transported to the root and, thus, the contribution of reduced sulfur transported to, vs. reduced sulfur synthesized in the root to protein synthesis can not be estimated. However, the finding that sulfate can be reduced in root cells does not necessarily mean that such a reduction occurs in appreciable amounts in the intact plant. At least in the light it may be efficient to use the cheap energy produced during photosynthesis to reduce sulfate rather than the expensive energy generated in degradative processes.

Transgenic tobacco containing and expressing the legume gene of a sulfur-rich storage protein can be seen as a model system not only for creating cereals with high sulfur, but also with high lysine content. Apparently, genes expressed in the endo-

sperm of the dicotyledons acting as the donor are also expressed in the endosperm of transgenic monocotyledons. The signal involved is still unknown. If there are a number of genes for storage proteins like in barley, it might not be sufficient to create a transgenic plant with one additional gene to achieve high sulfur content; it might be necessary to engineer the promotor of the gene so that it can be expressed at a higher level. A major concern, however, is whether or not there will be sufficient precursors, *i.e.* enough cysteine and methionine available for the synthesis of high amounts of sulfur rich storage proteins. At present it can not be taken for granted that the entire machinery for sulfur reduction, assimilation, and transport can supply the amount of sulfur amino acids needed to obtain cereals high in sulfur rich storage proteins.

### **Section 3.**

## **Environmental and agricultural aspects of sulfur metabolism**

## **Contents**

3.1	L.J. De Kok, Sulfur metabolism in plants exposed to atmospheric sulfur	111
3.2	W.H.O. Ernst, Ecological aspects of sulfur metabolism	131
3.3	J.F. Thompson and J.T. Madison, The effect of sulfate and methionine on legume proteins	145
3.4	Discussion	159

# SULFUR METABOLISM IN PLANTS EXPOSED TO ATMOSPHERIC SULFUR

Luit J. De Kok

*Department of Plant Physiology, University of Groningen, P.O. Box 14, 9750 AA Haren, The Netherlands*

## Contents

Introduction	111
Foliar deposition of atmospheric sulfur gases	112
Metabolism of deposited atmospheric sulfur	113
– Accumulation of sulfate	114
– Sulphydryl accumulation	115
H <sub>2</sub> S emission	116
Regulation of uptake and assimilation of sulfur in presence of excess foliar sulfur	117
Uptake and transport of sulfate	117
– Sulfate reduction	118
– Sulfur assimilation	118
Phytotoxicity of SO <sub>2</sub> and H <sub>2</sub> S	120
Concluding remarks	122
Literature cited	122

## Introduction

Sulfur is an essential element for plant growth; deficiency may result in reduced yield and quality of crops (54, 144, 186). The sulfur requirement of plants depends on the developmental stage and it varies between species (38, 54, 100, 185, 186).

The sulfur content of plants varies between 0.1 to 1.5 % of dry weight (54, 100). In general sulfur deficient crops have a total sulfur level lower than 0.15 %. Crop plants, exposed to excess sulfur in the soil, show levels higher than 0.5 % and contain high levels of sulfate (100, 144). The N/S ratio of plants or seeds is often used as a measure for the sulfur status (32, 55, 65, 145, 178). At a sufficient sulfur supply the organic N/S ratio on a molar basis of various species ranged from 30 to 40 (55). Even though various diagnostic tests such as total sulfur content, sulfate content, sulfate-sulfur to total sulfur ratio, nitrogen to sulfur ratio, may be useful in order to obtain insight into the sulfur status of plants, the status of other essential elements and other nutritional factors that affect plant growth have to be considered (100).

In many areas of the world sulfur deficiency of the soils has been demonstrated and sulfur fertilization is needed to optimize crop yield (190). On the other hand plants which grow in gypsum and salt marsh soils have to deal with a supply in the

root environment, which far exceeds the requirements for optimal growth (31, 186).

Plants which grow in areas with volcanic activity or close to sulfur springs have to cope with high levels of atmospheric sulfur deposition ( $\text{SO}_2$ ,  $\text{H}_2\text{S}$ ; 103, 136, 143). Also in industrialized areas plants are subjected to high levels of atmospheric sulfur deposition. In rural areas the atmospheric concentrations of  $\text{SO}_2$  and  $\text{H}_2\text{S}$  are generally lower than  $7 \times 10^{-3}$  and  $5 \times 10^{-5} \mu\text{l l}^{-1}$ , respectively (103, 169). However, in strongly industrialized areas the annual mean  $\text{SO}_2$  concentration is greater than  $0.038 \mu\text{l l}^{-1}$  (6) and even peak levels up to  $0.7 \mu\text{l l}^{-1}$  occur (136). High levels of  $\text{H}_2\text{S}$  occur only locally. In the vicinity of geothermal wells levels up to  $0.1 \mu\text{l l}^{-1}$  are measured (134). Industrial pollution may result in high local  $\text{H}_2\text{S}$  concentrations which exceed  $0.25 \mu\text{l l}^{-1}$  (49, 126). Dry and wet deposition of sulfurous air pollutants to natural vegetation and crops may be a significant factor in sulfur fertilization in industrialized areas (75, 93, 103, 143). *E.g.* it has been estimated that about 23 % of the Western Europe area is subjected to an annual atmospheric  $\text{SO}_2$  deposition greater than  $38 \text{ kg ha}^{-1}$  (6). For the agricultural areas in the U.K. even an annual dry deposition of  $72 \text{ kg SO}_2 \text{ ha}^{-1}$  has been estimated (63). These depositions are greater than the sulfur requirements of most crops, which vary between 10 to  $50 \text{ kg ha}^{-1}$  per annum (38, 54). A high foliar sulfur deposition may result in damage to vegetation and reduced crop yields ( $\text{SO}_2$ : 7, 8, 64, 112, 116, 120, 133, 204, and  $\text{H}_2\text{S}$ : 48, 112, 122, 123, 125, 134, 176, 177, 189). However, at low soil sulfur levels deposition of atmospheric sulfur compounds may be beneficial and serve as a source for plant nutrition ( $\text{SO}_2$ : 6, 21, 36, 37, 57, 58, 60, 61, 64, 117, 118, 139, 185, 186, and  $\text{H}_2\text{S}$ : 19, 57).

The present paper reviews the response of sulfur metabolism of plants which have to cope with excess sulfur in the shoot environment.

### Foliar deposition of atmospheric sulfur gases

Plants form a sink for atmospheric pollutants, which can directly be absorbed by the foliar tissue (94). The deposition velocity of air pollutants depends on both chemical and physical factors as adsorption to leaf surfaces, diffusive path length, solubility in cell sap, reactivity with cellular components, and physiological factors as regulation of stomatal opening and metabolism of the pollutant (12, 30, 68, 87, 92, 113, 114, 182, 193, 194).

*Sulfur dioxide.* Atmospheric  $\text{SO}_2$  was rapidly absorbed by leaves and over a wide range its flux was nearly linear with concentration and duration of the exposure (94, 181). In light,  $\text{SO}_2$  flux to leaves generally predominantly proceeded via the stomates (63, 69, 138, 140, 181, 182), although  $\text{SO}_2$  may be adsorbed by the leaf surface or pass through the cuticle (63, 69, 87, 119, 182). The deposition velocities for  $\text{SO}_2$  differed strongly between species and depended on the experimental conditions; daytime deposition velocities ranged from  $0.02$  to  $1.5 \text{ cm s}^{-1}$  (35, 63, 89, 140, 181, 182). The deposition velocities for  $\text{SO}_2$  were often close to or even higher than those predicted from stomatal conductance for aqueous vapor efflux. It has been observed that the internal (mesophyll) resistance for  $\text{SO}_2$  gas flux was low and that the diffusion through the stomates (stomatal conductance) limited the flux of  $\text{SO}_2$  to leaves

high solubility and a rapid hydration of  $\text{SO}_2$  in the cell sap, resulting in formation of sulfuric acid and an internal  $\text{SO}_2$  vapor pressure approaching zero, rather than to an intracellular metabolism of the absorbed sulfite (114, 133, 140, 141, 142, 181, 182, 187, 204).

**Hydrogen sulfide.** Plant shoots rapidly absorbed atmospheric  $\text{H}_2\text{S}$ . In contrast to  $\text{SO}_2$ ,  $\text{H}_2\text{S}$  flux to shoots depended on the atmospheric  $\text{H}_2\text{S}$  concentration. In light,  $\text{H}_2\text{S}$  flux to shoots of various species was nearly linear with concentration up to an atmospheric level of about  $0.3 \mu\text{l l}^{-1}$  (53). At higher  $\text{H}_2\text{S}$  levels the flux of  $\text{H}_2\text{S}$  to shoots reached a maximum level (stomatal opening was unaffected). The  $\text{H}_2\text{S}$  flux to shoots proceeded predominantly via the stomates (53, 181). In the light, the deposition velocity for  $\text{H}_2\text{S}$  was close to that for aqueous vapor efflux at concentrations lower than  $0.3 \mu\text{l l}^{-1}$  for the species and under the conditions tested, which indicated a low internal (mesophyll) resistance for  $\text{H}_2\text{S}$  (the internal  $\text{H}_2\text{S}$  vapor pressure approaching zero) and diffusion through the stomata as the limiting factor in the deposition of  $\text{H}_2\text{S}$  (53). For the species and exposure conditions tested, the deposition velocities for  $\text{H}_2\text{S}$  in the light ranged from  $0.005$  to  $0.36 \text{ cm s}^{-1}$  (35, 53, 182). Flux of  $\text{H}_2\text{S}$  to shoots varied diurnally with stomatal opening, but was rather constant for several days (53). A high  $\text{H}_2\text{S}$  deposition velocity was only observed at a high metabolic activity of the tissue and only then stomatal conductances for  $\text{H}_2\text{S}$  influx and aqueous vapor efflux were similar (35). It was suggested that in contrast to  $\text{SO}_2$ , the metabolism of the absorbed  $\text{H}_2\text{S}$  is the significant factor responsible for the low internal (mesophyll) resistance for  $\text{H}_2\text{S}$  (35, 53).

### Metabolism of deposited atmospheric sulfur

Atmospheric  $\text{SO}_2$  and  $\text{H}_2\text{S}$  may be used as a sulfur source for plants and at low atmospheric levels they may be beneficial and result in an increased yield when the sulfur supply to the roots is limited, however, above a certain atmospheric concentration, foliar deposition of  $\text{SO}_2$  or  $\text{H}_2\text{S}$  may exceed sulfur requirement for plant growth (6, 36, 37, 57, 58, 60, 61, 64, 117, 118, 139, 185, 186).

Carbonyl sulfide (COS), which is thought to be the predominant natural sulfur gas in the atmosphere (191) may also be rapidly absorbed by the plant (182) and metabolized, most likely, after hydrolysis to  $\text{H}_2\text{S}$  and  $\text{CO}_2$  (16). However, its atmospheric concentration is too low to contribute significantly to the sulfur nutrition of the plant.

The possible significance of atmospheric sulfur deposition as a source for plant nutrition will be illustrated by the following example. For growth spinach plants require about  $10 \mu\text{mol sulfur g fresh weight}^{-1}$  (124). Supposed that the estimated daily shoot conductance of spinach for aqueous vapor efflux is  $0.08 \text{ cm s}^{-1}$  (adapted from ref. 53) and the deposition velocities of  $\text{SO}_2$  and  $\text{H}_2\text{S}$  are close to shoot conductance for aqueous vapor efflux, then a continuous atmospheric concentration of  $\text{SO}_2$  and  $\text{H}_2\text{S}$  of about  $0.4$  and  $0.3 \mu\text{l l}^{-1}$ , respectively, would be required to cover the needs of a plant growing at 15 %, when solely the atmospheric sulfur would be utilized as source. However, inorganic and organic sulfur already accumulate in the



plant at lower atmospheric  $\text{SO}_2$  and  $\text{H}_2\text{S}$  levels, which indicates that metabolism of the absorbed atmospheric sulfur is for the greater part beyond direct regulatory control.

### *Accumulation of sulfate*

**Sulfur dioxide.** Exposure of plants to  $\text{SO}_2$  resulted in enhanced sulfur levels in the shoots, which already could be observed at relative low levels upon exposure (even at  $0.04 \mu\text{l l}^{-1}$ ) and which predominantly could be ascribed to an accumulation of sulfate (21, 26, 42, 57, 58, 61, 69, 70, 83, 84, 85, 86, 97, 99, 107, 108, 123, 124, 125, 187, 203). The level of sulfur accumulation depended on the  $\text{SO}_2$  concentration, duration of exposure, air temperature and the sulfur supply to the roots; it varied between species (83, 84, 85, 86, 107, 108, 115, 117, 118, 123, 124, 125, 137, 138, 183, 187, 192, 203).

In general the sulfite content of leaf tissue exposed to  $\text{SO}_2$  was below the detection limit (21, 82, 99). Only at relatively high  $\text{SO}_2$  levels ( $> 0.5 \mu\text{l l}^{-1}$ ), significant intracellular sulfite concentrations occurred (62, 70, 99, 199). Thus, at realistic ambient concentrations, the absorbed  $\text{SO}_2$  is rapidly oxidized to sulfate in the cell. The nature of this oxidation is still obscure. Enzymes as peroxidase and cytochrome oxidase are able to oxidize sulfite, but also several catalysts as metal ions and superoxide radicals are known to stimulate sulfite oxidation (62, 87, 109, 133, 204). Until now there is no evidence that a specific 'sulfite oxidase' is involved in oxidation of sulfite.

In studies with spinach, it was observed that the increase in sulfate content of shoots was linear for at least six days upon exposure to  $0.25 \mu\text{l l}^{-1}$  (124). After two weeks of exposure the accumulation rate was reduced by 70 %. The sulfate content of spinach shoots increased up to  $20 \mu\text{mol g fresh weight}^{-1}$  upon prolonged exposure to  $0.25 \mu\text{l l}^{-1}$   $\text{SO}_2$ , whereas it was about  $3 \mu\text{mol g fresh weight}^{-1}$  in control plants. In spinach shoots the sulfate accumulation increased with temperature and did not reflect the solubility of  $\text{SO}_2$  in water (124). The sulfate content of roots was not substantially affected by  $\text{SO}_2$  exposure, even not after prolonged exposure (123, 124). However, there is evidence that sulfate may be transported from the shoots to the roots (10, 11, 13, 67, 91). It has been also demonstrated that sulfur originating from absorbed atmospheric  $\text{SO}_2$  was translocated to the roots and appeared in several sulfur fractions including sulfate (57, 58, 61). Furthermore, part of the absorbed  $\text{SO}_2$  was excreted into the root environment (69, 71). However, the translocation of the accumulated sulfate from the shoot to the roots apparently was too low to obtain sulfate accumulation in the roots. Cessation of  $\text{SO}_2$  exposure resulted in a decrease of the accumulated sulfate in spinach shoots, which was most likely due to metabolism and dilution of the accumulated sulfate by growth (124).

**Hydrogen sulfide.** Similar to  $\text{SO}_2$ , exposure of plants to  $\text{H}_2\text{S}$  ( $> 0.03 \mu\text{l l}^{-1}$ ) also resulted in an increased sulfur content of the plants (19, 57, 176, 177, 189) which could be partially ascribed to enhanced levels of sulfate (19, 43, 123, 124, 125). However, in most species sulfate accumulation occurred less rapidly than that observed with  $\text{SO}_2$  at equal concentrations (123, 124, 125). The origin of the accumulated sulfate is still unclear. Accumulation of sulfate may be due to a lack of regulation of sulfate uptake by the root and translocation to the shoot, since  $\text{H}_2\text{S}$  is

directly utilized as sulfur source. On the other hand, it may originate from oxidation of absorbed atmospheric sulfide or the sulfide produced during degradation of reduced sulfur compounds such as cysteine (90, 154). It has been demonstrated that superoxide radicals, for example, produced during photosynthetic electron transport may initiate sulfide oxidation (47). In contrast to  $\text{SO}_2$ , prolonged  $\text{H}_2\text{S}$  exposure of spinach resulted in a substantial increase of sulfate content of the roots; a 2-fold increase after two weeks of exposure to 0.15 and 0.3  $\mu\text{l l}^{-1}$  (123). Whether the accumulated sulfate in the roots originated from transport of sulfur compounds from the shoot to the root, or from a reduced translocation of sulfate from the root to the shoot is unclear (123).

### *Sulfhydryl accumulation*

**Sulfur dioxide.** A small part of  $\text{SO}_2$  absorbed by foliar tissue was directly reduced and assimilated, and appeared in several organic sulfur fractions of the plant (47, 58, 59, 61, 62, 69, 70, 71, 99, 108, 168, 175, 187, 188, 199, 205). Enhanced levels of water-soluble non-protein sulfhydryl compounds have commonly been observed in plants upon exposure to  $\text{SO}_2$  (1, 26, 28, 33, 52, 70, 78, 79, 80, 81, 82, 123, 124, 125, 130, 192). The level of accumulation varied with the level of  $\text{SO}_2$  pollution, and also between species (33, 80, 123).  $\text{SO}_2$ -induced accumulation of sulfhydryl compounds was rapid (1, 33, 52, 124, 125); after 24 h of exposure accumulation in spinach shoots had reached the maximal level (124). In spinach plants with open stomates an increase in sulfhydryl compounds in darkness comparable to that in light was noted, demonstrating that the absorbed  $\text{SO}_2$  could be reduced and assimilated in darkness (52). Even though in most species  $\text{SO}_2$ -induced sulfhydryl accumulation has been ascribed to enhanced levels of GSH (1, 33, 80, 81, 82, 125), in spinach leaves high levels of cysteine were also observed (28, 52). In darkness there was hardly any increase in GSH content; the enhanced sulfhydryl content was due to increased levels of cysteine and  $\gamma$ -glutamylcysteine; the latter was only present in trace amounts in untreated plants in the dark (28, 52). Part of the assimilated  $\text{SO}_2$ , as cysteine and GSH was transported to other parts of the plant (70).

Grill et al. (81, 82) also observed enhanced protein-sulfhydryl levels in needles of *Picea abies* collected from trees in strongly  $\text{SO}_2$  polluted areas.

**Hydrogen sulfide.**  $\text{H}_2\text{S}$  can be directly incorporated into reduced sulfur compounds as cysteine (20). Crop plants rapidly accumulated water-soluble sulfhydryl compounds in the shoots upon exposure to  $\text{H}_2\text{S}$  at the concentration of 0.03  $\mu\text{l l}^{-1}$  or higher (48, 122, 123). Already after one hour of exposure of spinach to 0.25  $\mu\text{l l}^{-1}$   $\text{H}_2\text{S}$ , a significant increase in sulfhydryl content was detected (49, 124). Maximum accumulation at this concentration, 3- to 4-fold of that in control plants, was observed after 24 h of exposure (49, 123).

The level of sulfhydryl accumulation in shoots depended on the  $\text{H}_2\text{S}$  concentration and it varied between species (48, 123, 124, 125). For spinach shoots it was maximal (5-fold of that of untreated plants) at 1  $\mu\text{l l}^{-1}$  after 24 h of exposure (124). The level of  $\text{H}_2\text{S}$ -induced sulfhydryl accumulation in spinach shoots was affected by temperature during the exposure (123, 124). At 15°C the sulfhydryl level was 1.6-fold higher than that at 25°C after 48 h of exposure to 0.25  $\mu\text{l l}^{-1}$   $\text{H}_2\text{S}$  (124). However, also in untreated plants the level of sulfhydryl compounds increased at a lower tem-

perature; relative ratio of sulfhydryl compounds in percentage upon  $\text{H}_2\text{S}$  exposure was independent of temperature (124). The duration and the intensity of irradiation during the  $\text{H}_2\text{S}$  exposure did not affect the level of sulfhydryl accumulation in spinach shoots (49, 124). Young spinach leaf tissue accumulated more sulfhydryl compounds than older tissue, however, relative ratio of sulfhydryl compounds in percentage upon  $\text{H}_2\text{S}$  exposure was comparable for all leaves (43). Exposure of spinach to  $0.25 \mu\text{l l}^{-1} \text{H}_2\text{S}$  resulted an increase in the level of sulfhydryl compounds in darkness comparable to that in light (49, 52). Sulfhydryl accumulation in spinach shoots upon  $\text{H}_2\text{S}$  exposure was due to enhanced levels of cysteine and GSH in the light (28, 43, 52). Upon dark exposure substantial quantities of  $\gamma$ -glutamylcysteine also accumulated (28). Glutathione was predominantly present in its reduced form, even after  $\text{H}_2\text{S}$  exposure ( $> 85 \%$ ) and the glutathione reductase activity was not substantially affected by short-term  $\text{H}_2\text{S}$  exposure to  $0.25 \mu\text{l l}^{-1}$  (50).

Short-term  $\text{H}_2\text{S}$  exposure did not affect the water-soluble protein sulfhydryl content (49).

From  $\text{H}_2\text{S}$  flux measurements it was calculated that, after an exposure to 0.2 or  $0.8 \mu\text{l l}^{-1} \text{H}_2\text{S}$  for 3 days, 25 % of the total  $\text{H}_2\text{S}$  taken up by spinach shoots could be revealed in the water-soluble non-protein sulfhydryl compounds (53). These data indicated that during the first 24 h of exposure the greater part of the  $\text{H}_2\text{S}$  taken up by the shoots was incorporated into sulfhydryl compounds, since maximum accumulation of these compounds was reached after 24 h (49, 124). In addition, the observation that the  $\text{H}_2\text{S}$  flux to shoots was rather constant up to 4 days of exposure, indicated that the rate of accumulation of sulfhydryl compounds in the shoots did not reflect the  $\text{H}_2\text{S}$  uptake by plants (53). The fate of the remaining fraction of  $\text{H}_2\text{S}$  taken up by the plant was unclear. Part of the reduced sulfur could be utilized for plant growth (53, 125) or oxidized to sulfate and be responsible for the increased sulfate content upon prolonged  $\text{H}_2\text{S}$  exposure (43, 122, 123, 124, 125). Finally part of the absorbed sulfur could be translocated to other parts of the plant (14, 57, 58, 61). A two days exposure of spinach to  $0.25 \mu\text{l l}^{-1} \text{H}_2\text{S}$  resulted in a two-fold increase in GSH content in the roots, which indicated that part of the accumulated GSH in the shoots upon exposure was transported to the roots (F. Buwalda & W. Visser, personal communication).

From the observed high  $\text{H}_2\text{S}$  fluxes to shoots and the rapid incorporation of  $\text{H}_2\text{S}$  into the compounds of the sulfur assimilatory pathway, cysteine,  $\gamma$ -glutamylcysteine and GSH, it was suggested that rapid metabolism of the absorbed  $\text{H}_2\text{S}$  directly into cysteine was significant for the high deposition velocity of  $\text{H}_2\text{S}$  at concentrations lower than  $0.3 \mu\text{l l}^{-1}$  (53). In addition, it was concluded that O-acetylserine sulfhydrylase has a very high affinity for  $\text{H}_2\text{S}$  *in vivo* (53).

### *Hydrogen sulfide emission*

Even though plants act as a sink for  $\text{H}_2\text{S}$ , part of the absorbed  $\text{SO}_2$  is re-emitted as  $\text{H}_2\text{S}$  after reduction. Materna (129) reported emission of volatile sulfur by spruce needles which had been previously exposed to  $\text{SO}_2$ . De Cormis (42) demonstrated that  $\text{SO}_2$ -induced emission of volatile sulfur was a light dependent process and that  $\text{H}_2\text{S}$  was emitted by the leaves. Plants grown under normal sulfur conditions also

emitted small quantities of  $\text{H}_2\text{S}$  (62, 201, 158). At a sulfate concentration in the root environment of 1 mM, which is adequate for growth of crop plants, *Glycine max* plants emitted about  $0.007 \mu\text{mol H}_2\text{S (g dry weight)}^{-1} \text{ h}^{-1}$  in the light (201). Spruce branches continuously emitted  $\text{H}_2\text{S}$ , at high rates in the light and at low rates in darkness; there was a direct relation between the aqueous vapor efflux from the needles and the rate of  $\text{H}_2\text{S}$  emission ( $1 \text{ nmol H}_2\text{S mol H}_2\text{O}^{-1}$ ; 158).

Upon  $\text{SO}_2$  exposure the rate of  $\text{H}_2\text{S}$  emission may be substantial in the light; up to 15 % of the deposited sulfur by the leaves was found to be re-emitted (62, 164, 181). At concentrations higher than  $0.5 \mu\text{l l}^{-1} \text{ SO}_2$ , the  $\text{H}_2\text{S}$  emission of *Geranium* leaves exceeded a rate of  $0.8 \mu\text{mol (g dry weight)}^{-1} \text{ h}^{-1}$  (181).  $\text{H}_2\text{S}$  emission upon  $\text{SO}_2$  exposure may result in an underestimation of the actual foliar  $\text{SO}_2$  deposition (179, 181). There is a threshold  $\text{SO}_2$  concentration required before substantial  $\text{H}_2\text{S}$  emission by leaves could be detected (88, 181). Taylor and Tingey (181) calculated a threshold level for *Geranium* of  $5 \text{ nmol cm}^{-2}$  over 15 min period. The rate of  $\text{H}_2\text{S}$  emission depended on leaf age and  $\text{SO}_2$  concentration; it varied strongly between species (62, 88, 164, 181).

Application of sulfite or high levels of sulfate to the roots or incubation of leaf tissue with sulfite, sulfate or cysteine also resulted in high rates of  $\text{H}_2\text{S}$  emission (111, 148, 150, 151, 152, 154, 155, 156, 165, 166, 167, 174, 180, 200). In contrast to that induced by sulfate, sulfite or  $\text{SO}_2$ , cysteine-induced  $\text{H}_2\text{S}$  emission was light independent.  $\text{H}_2\text{S}$  was directly derived from cysteine by enzymatic degradation by cysteine desulfhydrase (104, 151, 154, 156, 165). The presence of separate cysteine desulfhydrases for L-cysteine and D-cysteine have been demonstrated in leaf tissue, but the physiological role of the latter enzyme is obscure, since its substrate D-cysteine is unknown in plant tissue (156, 162).

## Regulation of uptake and assimilation of sulfur in presence of excess foliar sulfur

### *Uptake and transport of sulfate*

Uptake and transport of sulfate is affected by the sulfur status of the plant. Plants with a high sulfur status generally have less efficient sulfate uptake by the roots than plants with a low sulfur status (34, 95). This was also found for sulfur transport into cell suspensions (101, 170, 171). Uptake and transport of sulfate in the plant is regulated by negative feedback from sulfate itself (39, 40, 161) and by repression of the uptake system (especially in root type cells) by reduced sulfur compounds as GSH (153, 157). Little is known of the effect of foliar deposition of  $\text{SO}_2$  and  $\text{H}_2\text{S}$  on the sulfate uptake by the roots. It has been demonstrated that at high levels of atmospheric  $\text{SO}_2$  ( $0.5 \mu\text{l l}^{-1}$ , tobacco; 58) or  $\text{H}_2\text{S}$  ( $18 \mu\text{l l}^{-1}$ , duckweed; 19) the sulfate uptake by the roots was reduced. In order to obtain more insight into the regulatory aspects of sulfur metabolism, the significance of negative feedback control of sulfate uptake by roots at low levels of foliar deposition of atmospheric sulfur needs further study.

### Sulfate reduction

The activities of the enzymes of the assimilatory sulfate reduction in leaves depend on the developmental stage (2, 18, 66, 163, 198, 202), and on nitrogen and sulfur nutrition (3, 4, 5, 9, 24, 27, 29, 72, 159, 160). Feedback regulation of assimilatory sulfate reduction predominantly occurs at the site of adenosine 5'-phosphosulfate sulfotransferase (APSSTase), cysteine being the most likely regulator (17, 22, 23, 25, 27, 196, 198). Feedback regulation of APSSTase is due to both inactivation/degradation and repression of the enzyme (17, 196). The ferredoxin-dependent sulfite reductase of *Pisum sativum* may also be subject to feedback regulation: *in vitro* it was inactivated by sulfide (100 % at 0.1 mM; 197). There was no feedback regulation of the activities of ATP sulfurylase and O-acetylserine sulfhydrylase by low levels of reduced sulfur compounds (23, 25, 56, 135, 196, 198).

The activity of ATP sulfurylase was not (or only slightly) reduced upon exposure to SO<sub>2</sub> (0.025 to 0.075 μl l<sup>-1</sup>; 26, 192). Exposure of plants to SO<sub>2</sub> resulted in a decrease in APSSTase activity (26, 192, 203). Even at low levels of SO<sub>2</sub> the loss of APSSTase may be substantial. Exposure of *Fagus sylvatica* to 0.025 μl l<sup>-1</sup> SO<sub>2</sub> resulted in a 70 % loss of this enzyme within three days of exposure (26). This decrease occurred before a significant increase of sulfate was observed (26). O-acetylserine sulfhydrylase activity was not affected by SO<sub>2</sub> exposure (1.2 μl l<sup>-1</sup>; 203).

Exposure of *Lemna minor* to high H<sub>2</sub>S levels (12 μl l<sup>-1</sup>) for 6 days did not affect ATP sulfurylase activity (22). However, H<sub>2</sub>S exposure (1.5 μl l<sup>-1</sup>) during the development of leaves of *Pisum sativum*, repressed ATP sulfurylase activity during the first days of exposure (198). H<sub>2</sub>S exposure resulted in a loss of APSSTase activity of leaves or cell suspensions (22, 25, 196, 198, 202), however, only relatively high levels (> 1.5 μl l<sup>-1</sup>) of this sulfur gas were used. O-Acetylserine sulfhydrylase was not affected upon H<sub>2</sub>S exposure (17, 22, 196, 198, 202).

In conclusion, there is evidence that exposure of plants to SO<sub>2</sub> or H<sub>2</sub>S may reduce assimilatory sulfate reduction in the shoots, due to repression of the APSSTase activity, most likely mediated by the enhanced levels of cysteine upon exposure. More research is needed in order to understand the significance of the feedback control of sulfate reduction in the regulation of sulfur metabolism in presence of excess sulfur.

### Sulfur assimilation

Accumulation of sulfhydryl compounds in leaf tissue is characteristic under conditions where the reduced sulfur supply exceeds the metabolic needs (44, 45, 46, 50, 147, 149). Inhibition of sulfate reduction by selenate, strongly reduced sulfhydryl accumulation in leaf tissue exposed to excess sulfur (43, 44).

A combined exposure of leaf discs to 25 mM Na<sub>2</sub>SO<sub>4</sub> and 0.5 μl l<sup>-1</sup> H<sub>2</sub>S for 24 h in the light demonstrated that the content of sulfhydryl compounds was not the sum of those induced by H<sub>2</sub>S and sulfate (43). The combined exposure resulted in an intermediate sulfhydryl level, indicating that sulfide from both sulfur sources competed for the same substrates utilized for synthesis of sulfhydryl compounds.

The increase in sulfhydryl content upon exposure of spinach leaf tissue to SO<sub>2</sub> and H<sub>2</sub>S could be ascribed to enhanced levels of GSH and cysteine in light and cysteine and γ-glutamylcysteine in darkness (28, 52). Incubation of spinach leaf tissue

with sulfate also resulted in similar enhanced levels of both cysteine and GSH in light, and of  $\gamma$ -glutamylcysteine in darkness (28, 52). This indicated that the regulation of the cysteine pool was rather poor in the presence of excess sulfur, even when sulfate reduction was limiting synthesis of the sulfhydryl compounds. This observation is in contrast with earlier suggestions that the cysteine pool is carefully regulated and that GSH functions as storage form of cysteine (50, 62, 147, 149). Even after two weeks exposure of spinach to  $H_2S$ , high levels of both cysteine and GSH were still present; regulation of the intracellular sulfhydryl compounds was not altered after prolonged exposure in such a way that low cysteine levels were obtained (43).

Incubation of spinach leaf discs with 1 mM buthionine sulfoximine (BSO), a selective inhibitor of  $\gamma$ -glutamylcysteine synthetase (131) only slightly decreased the sulfhydryl content. This was also the case for  $H_2S$ -induced sulfhydryl accumulation ( $0.5 \mu l^{-1} H_2S$ ; 43). The cysteine fraction was strongly enriched after BSO incubation, from 8 to 76 % in control leaf discs and from 43 to 70 % in  $H_2S$ -fumigated leaf discs (43). These results demonstrated a rapid turnover of GSH in non-fumigated leaf discs and again a relatively poor regulation of the cysteine pool, when GSH synthesis was prevented. In addition, it was shown that  $H_2S$ -induced sulfhydryl accumulation was hardly affected under conditions where  $\gamma$ -glutamylcysteine and GSH synthesis were inhibited, indicating metabolism of absorbed atmospheric  $H_2S$  was not subject to feedback regulation by cysteine.

The occurrence of high levels of  $\gamma$ -glutamylcysteine in spinach leaf tissue in darkness after exposure to excess sulfur was not due to a light dependency of glutathione synthetase, but due to limit of glycine needed for GSH synthesis. Accumulation of  $\gamma$ -glutamylcysteine could be prevented by addition of glycine to the leaves and GSH instead of  $\gamma$ -glutamylcysteine accumulated (Buwalda, F., Stulen, I. and De Kok, L.J., in preparation).

There is little information on the subcellular distribution of the sulfhydryl compounds. Smith et al. (173) reported that GSH was predominantly present in the chloroplast (> 50%), however, Gillham and Dodge (73) and Klapheck et al. (105) reported that less than 35% of GSH was present in the chloroplasts. Smith (172) suggested that excess reduced sulfur compounds are stored in the vacuole. The subcellular localization of the accumulated sulfhydryl compounds in leaf tissue upon exposure to excess sulfur also needs further investigation.

In most species tested the level of sulfhydryl accumulation upon  $SO_2$  exposure was much lower than that upon  $H_2S$  exposure (123, 124, 125). This can be explained by the fact that the greater part of the absorbed  $SO_2$  was oxidized and thus revealed as increased sulfate levels and only a small proportion was reduced to sulfide and subsequently incorporated into sulfhydryl compounds. Grill et al. (80) suggested that the increased GSH levels in leaves of  $SO_2$ -exposed plants were due to chronically enhanced sulfate levels. Incubation of leaf tissue with high sulfate levels resulted in a strongly increased intracellular sulfate content and in enhanced levels of water-soluble non-protein sulfhydryl compounds (44, 46, 52, 80, 82). The level of sulfhydryl accumulation depended on the supplied sulfate concentration (46). In contrast to the above observations of sulfate incubation of leaf tissue, in  $SO_2$ -exposed plants sulfhydryl accumulation was not directly related to the sulfate content in the leaves. The sulfhydryl accumulation already reached a maximum level after one day of exposure and the sulfate content increased linearly for at least six days of exposure (123,

124, 125). These results indicated that the sulfate accumulating upon  $\text{SO}_2$  exposure was not localized at the site where sulfate reduction took place, but it was more likely stored in the vacuole (124). The latter conclusion was supported by the observation that the vacuole is the major storage site of sulfate (102, 172, 184).

Sulfhydryl accumulation in shoots upon exposure to  $\text{SO}_2$  and  $\text{H}_2\text{S}$  was rapid during the first hours of exposure and accumulation reached a maximum level after 24 to 48 h of exposure (49, 124). However, deposition of  $\text{SO}_2$  (illustrated by the sulfate accumulation in the shoots; 124) or  $\text{H}_2\text{S}$  (53) continued unaltered after this period. Inhibition of sulfate reduction may explain the occurrence of such a steady state level of sulfhydryl accumulation. In this case the plant would use the absorbed atmospheric sulfur as a sulfur source instead of sulfate taken up by the root.

When the exposure of leaves to excess sulfur was ceased then the accumulated sulfhydryl compounds were most likely metabolized or partially transported to the roots. Termination of the  $\text{H}_2\text{S}$  exposure resulted in a rapid loss of the accumulated sulfhydryl compounds within two days (49, 50, 124). The oxidized glutathione content also decreased and no detectable emission of  $\text{H}_2\text{S}$  by shoots was noticed after termination of the  $\text{H}_2\text{S}$  exposure, indicating that desulfhydration of cysteine was not significantly involved in the loss of the accumulated sulfhydryl compounds (50). It was proposed that the accumulated sulfhydryl compounds were metabolized after cessation of the fumigation and used for *e.g.* protein synthesis (50, 124). The loss of sulfhydryl compounds was not significantly affected by temperature (15, 20 and 25°C), photon fluence rate (60 and 170  $\mu\text{mol m}^{-2} \text{s}^{-1}$ ) or  $\text{H}_2\text{S}$  pre-exposure concentration (0.25 and 0.5  $\mu\text{l l}^{-1}$ ; 124). However, it was calculated that the rate of decrease of the accumulated sulfhydryl compounds was insufficient to meet the organic sulfur demand needed for plant growth under the different conditions (124).

The methionine level is subject to strong feedback control (Giovanelli, this volume; 74). Its content was not substantially affected by sulfur nutrition (41),  $\text{SO}_2$  exposure (76, 128) and  $\text{H}_2\text{S}$  (195).

In conclusion, in the presence of excess reduced sulfur the levels of water-soluble non-protein sulfhydryl compounds, cysteine,  $\gamma$ -glutamylcysteine, GSH are very poorly regulated. It is questionable whether the accumulation of the sulfhydryl compounds upon exposure to excess sulfur has a function in temporary storage of reduced sulfur in the shoot, or reflects a disturbed regulation of sulfur assimilation.

### Phytotoxicity of $\text{SO}_2$ and $\text{H}_2\text{S}$

$\text{SO}_2$  and  $\text{H}_2\text{S}$  are phytotoxic gasses, which, above a certain threshold level, may negatively affect plant growth; at acute levels exposure may result in visible injury (7, 8, 48, 64, 77, 112, 120, 122, 123, 125, 133, 134, 177, 189, 204). Sulfite and sulfide are very reactive compounds and part of the phytotoxicity of  $\text{SO}_2$  and  $\text{H}_2\text{S}$  very likely is due to a reaction of these compounds with cellular components as enzymes or membranes, resulting in a disturbed metabolism (51, 68, 92, 96, 110, 121, 126, 127, 133). The question arises whether part of the phytotoxicity of the sulfurous air pollutants can be attributed to a disturbed sulfur metabolism.

The relation between the sulfur status of the plant and the phytotoxicity of  $\text{SO}_2$  has been intensively studied. Deposition of atmospheric sulfur may be beneficial

when the sulfur supply to the roots was limited (6, 36, 37, 57, 58, 64, 117, 118, 139, 185, 186). For some species exposure to low levels of  $\text{H}_2\text{S}$  ( $0.03$  to  $0.1 \mu\text{l l}^{-1}$ ) resulted in enhanced yields, even under normal sulfur fertilization of the soil (48, 189). The cause of the  $\text{H}_2\text{S}$ -induced growth stimulation is still unclear.

It has been demonstrated that  $\text{SO}_2$  was less toxic when the sulfur status of the plant was low (98, 106, 108, 117, 118). This indicated that metabolism of the absorbed sulfur, at least partially, plays a role in detoxification of  $\text{SO}_2$ . It was demonstrated that genetic variation in susceptibility of Cucurbitaceae to acute injury could be attributed to differences in the rate of absorption of  $\text{SO}_2$  by the plant (15, 62). Similar results were obtained with regard to the sensitivity of different species towards  $\text{SO}_2$  (71, 108). However, upon  $\text{H}_2\text{S}$  exposure, there was no direct relation between the  $\text{H}_2\text{S}$  absorption by shoots and the sensitivity (yield reduction) of species to  $\text{H}_2\text{S}$  (53). In some studies the resident time of sulfite in the plant cell was related to the sensitivity of different species towards  $\text{SO}_2$  (99, 109, 132). However, in these experiments unrealistic high levels of sulfite were used and the physiological significance is unclear. In addition, it has been demonstrated that there was no direct relation between the extent of oxidation and the sensitivity of the leaf tissue (62).

There was a positive correlation between the susceptibility of leaves of Cucurbitaceae to acute injury and the capacity of re-emission of the absorbed sulfur as  $\text{H}_2\text{S}$  emission and it was suggested that this reaction was involved in detoxification of  $\text{SO}_2$  by the plant (62, 164). However, also in these studies high sublethal levels of  $\text{SO}_2$  were used. It is questionable whether  $\text{H}_2\text{S}$  emission is significantly involved in detoxification at low levels of  $\text{SO}_2$ , since here the plant may have sufficient capacity to incorporate the greater part of the reduced sulfur into cysteine and glutathione, as demonstrated in  $\text{H}_2\text{S}$  exposure experiments (124).

Sulfate is the major sulfur compound which accumulates in plants upon  $\text{SO}_2$  and (prolonged)  $\text{H}_2\text{S}$  exposures. At present there is no evidence that elevated intracellular sulfate levels (most likely stored in the vacuole; 102, 124) are of great importance for the phytotoxic effects of  $\text{SO}_2$  and  $\text{H}_2\text{S}$ . There was no direct relation between the level of sulfate accumulation and the phytotoxicity of  $\text{SO}_2$  or  $\text{H}_2\text{S}$  (123, 124, 125).

It has been suggested that chronically enhanced levels of sulfhydryl compounds in the cell may result in a deregulated intracellular metabolism (62, 80, 81, 82). Especially, high intracellular cysteine levels are considered to be toxic (62, 146). Even though plants contain cysteine degrading enzymes as cysteine desulfhydrase (151, 154, 156, 162, 165), high levels of cysteine apparently occur upon exposure to excess sulfur. Many species (especially monocotyledons upon  $\text{H}_2\text{S}$  exposure; I. Stulen and F.S. Posthumus, personal communication) tolerate high levels of both glutathione and cysteine in the presence of  $\text{SO}_2$  or  $\text{H}_2\text{S}$  without any phytotoxic effects, even after prolonged exposure (125). The localization of the accumulated sulfhydryl compounds upon excess sulfur and the physiological significance of cysteine desulfhydrase in regulation of the intracellular cysteine levels needs further study.

In conclusion, it is questionable whether a disturbed regulation of sulfur assimilation is a significant factor responsible for the phytotoxicity of  $\text{SO}_2$  and  $\text{H}_2\text{S}$ .



### Concluding remarks

Plant shoots rapidly absorb  $\text{SO}_2$  and  $\text{H}_2\text{S}$  and in general the diffusion through the stomates limits the flux of these gasses to the shoots. The internal (mesophyll) resistance for  $\text{SO}_2$  and  $\text{H}_2\text{S}$  is low; for  $\text{SO}_2$  it can be attributed to a high solubility of this gas in the cell sap, but for  $\text{H}_2\text{S}$  it is ascribed to its rapid metabolism. It is evident that already low atmospheric levels of  $\text{SO}_2$  or  $\text{H}_2\text{S}$  affect sulfur metabolism in plant shoots, which is illustrated by enhanced levels of sulfate and sulfhydryl compounds. There are indications that uptake of sulfate by the roots and regulation of sulfate reduction in the shoots may respond to foliar sulfur deposition. Thus, fumigation experiments may be used as a tool in order to obtain more insight into the regulatory aspects of sulfur metabolism in intact plants. In addition, the genetic differences in sulfur utilization between species in relation to their responses to atmospheric sulfur deposition, including evolutionary responses need further investigation.

### Acknowledgements

I wish to thank Prof.dr.ir. Pieter J.C. Kuiper and Dr. Ineke Stulen for critically reading of the manuscript.

### Literature cited

1. Alscher, R., Bower, J.L. and Zieler, W. 1987. The basis for different sensitivities of photosynthesis to  $\text{SO}_2$  in two cultivars of pea. *J. Exp. Bot.* 38: 99-108.
2. Adams, L.A. and Rinne, R.W. 1969. Influence of age and sulfur metabolism on ATP sulfurylase activity in soybean and a survey of selected species. *Plant Physiol.* 44: 1241-1246.
3. Archer, M.J. 1987. Effect of differential sulfur nutrition on the specific activity of ATP sulfurylase in mature grain from five wheat cultivars (*Triticum aestivum* L.). *Aust. J. Plant Physiol.* 14: 239-244.
4. Barney, P.E. and Bush, L.P. 1985. Interaction of nitrate and sulfate reduction in tobacco. 1. Influence of availability of nitrate and sulfate. *J. Plant Nutr.* 8: 505-515.
5. Barney, P.E. and Bush, L.P. 1985. Interaction of nitrate and sulfate reduction in tobacco. 2. Influence of apical meristem removal. *J. Plant Nutr.* 8: 517-526.
6. Bell, J.N.B. 1984. Air pollution problems in western Europe. In: Gaseous air pollutants and plant metabolism, Koziol, M.J. and Whatley, F.R. eds. pp. 3-24, London: Butterworths.
7. Bell, J.N.B. and Mudd, C.H. 1976. Sulphur dioxide resistance in plants: a case study of *Lolium perenne*. In: Effects of air pollutants on plants, Mansfield, T.A., ed. pp. 87-103, London: Cambridge University Press.
8. Bennett, J.H. and Hill, A.C. 1975. Interactions of air pollutants with canopies of vegetation. In: Responses of plants to air pollution, Mudd, J.B. and Kozłowski, T.T. eds. pp. 273-306, New York: Acad. Press.
9. Bergmann, L., Schwenn, J.-D. and Urlaub, H. 1980. Adenosine triphosphate sulfurylase and O-acetylserine sulfhydrylase in photoheterotrophically and heterotrophically cultured tobacco cell. *Z. Naturforsch.* 35: 952-957.
10. Biddulph, S.F. 1956. Visual indications of  $^{35}\text{S}$  and  $^{32}\text{P}$  translocation in the phloem. *Am. J. Bot.* 43: 143-148.
11. Biddulph, O., Biddulph S.F., Cory, R. and Koontz, H. 1958. Circulation pattern of phosphorus, sulfur and calcium in the bean plant. *Plant Physiol.* 33: 293-300.
12. Black, V.J. 1982. Effects of sulphur dioxide on physiological processes in plants. In: Effects of gaseous air pollution in agriculture and horticulture, Unsworth, M.H. and Ormrod, D.P. eds. pp. 67-91,

London: Butterworth Scientific.

13. Bonas, U., Schmitz, K., Rennenberg, H. and Bergmann, L. 1982. Phloem transport of sulfur in *Ricinus*. *Planta* 155: 82-88.
14. Brändle, R. and Schnyder, J. 1970. Abtransport von Schwefelverbindungen aus Bohnenprimärblättern (*Phaseolus vulgaris*) nach Begasung mit  $H_2^{35}S$ . *Experientia* 26: 1395-1396.
15. Bressan, R.A., Wilson, L.G. and Filner, P. 1978. Mechanism of resistance to sulfur dioxide in the Cucurbitaceae. *Plant Physiol.* 61: 761-767.
16. Brown, K.A., Kluczewski, S.M. and Bell, J.M.B. 1986. Metabolism of [ $^{35}S$ ]- carbonyl sulphide in perennial ryegrass (*Lolium perenne* L.) and radish (*Raphanus sativus* L.). *Environ. Exp. Bot.* 26: 355-364.
17. Brunold, C. 1981. Regulation of adenosine 5'-phosphosulfate sulfotransferase in higher plants. In: *Biology of inorganic nitrogen and sulfur*, Bothe, H. and Trebst, A. eds. pp. 352-358, Berlin: Springer-Verlag.
18. Brunold, C. 1983. Changes in ATP sulfurylase and adenosine 5'- phosphosulfate sulfotransferase activity during autumnal senescence of beech leaves. *Physiol. Plant* 59: 319-323.
19. Brunold, C. and Erismann, K.H. 1974.  $H_2S$  als Schwefelquelle bei *Lemna minor* L.: Einfluss auf das Wachstum, den Schwefelgehalt und die Sulfataufnahme. *Experientia* 30: 465-467.
20. Brunold, C. and Erismann, K.H. 1975.  $H_2S$  as sulfur source in *Lemna minor* L.: II. Direct incorporation into cysteine and inhibition of sulfate assimilation. *Experientia* 31: 508-510.
21. Brunold, C. and Erismann, K.H. 1976. Sulfur dioxide as sulfur source in duckweeds (*Lemna minor* L.) *Experientia* 32: 296-297.
22. Brunold, C. and Schmidt, A. 1976. Regulation of adenosine 5'- phosphosulfate sulfotransferase activity by  $H_2S$  in *Lemna minor* L. *Planta* 133: 85-88.
23. Brunold, C. and Schmidt, A. 1978. Regulation of sulfate assimilation in plants. 7. Cysteine inactivation of adenosine 5'-phosphosulfate sulfotransferase in *Lemna minor* L. *Plant Physiol.* 61: 342-347.
24. Brunold, C. and Suter, M. 1984. Regulation of sulfate assimilation by nitrogen nutrition in the duckweed *Lemna minor* L. *Plant Physiol.* 76: 579-583.
25. Brunold, C., Zryd, J.-P. and Lavanchy, P. 1981. Regulation of enzymes of assimilatory sulfate reduction in aerated cell suspensions of *Nicotiana sylvestris*. *Plant Sci. Lett.* 21: 167-174.
26. Brunold, C., Landolt, W. and Lavanchy, P. 1983.  $SO_2$  and assimilatory sulfate reduction in beach leaves. *Physiol. Plant.* 59: 313-318.
27. Brunold, C., Suter, M. and Lavanchy, P. 1987. Effect of high and low sulfate concentrations on adenosine 5'-phosphosulfate sulfotransferase activity from *Lemna minor*. *Physiol. Plant.* 70: 168-174.
28. Buwalda, F., De Kok, L.J., Stulen, I. and Kuiper, P.J.C. 1988. Cysteine,  $\gamma$ -glutamyl-cysteine and glutathione contents of spinach leaves as affected by darkness and application of excess sulfur. *Physiol. Plant.* 74: 663-668.
29. Cacco, G., Saccomani, M. and Ferrari, G. 1983. Changes in the uptake and assimilation efficiency for sulfate and nitrate in maize hybrids during the period 1930 through 1975. *Physiol. Plant.* 58: 171-174.
30. Cape, J.N. and Unsworth, M.H. 1988. Deposition, uptake and residence of pollutants. In: *Air pollution and plant metabolism*, Schulte-Hostede, S., Darrall, N.M., Blank, L.W. and Wellburn, R. eds. pp. 1-18, London: Elsevier Applied Science.
31. Carlson, Jr., P.R. and Forrest, J. 1982. Uptake of dissolved sulfide by *Spartina alterniflora*: Evidence from natural sulfur isotope abundance ratios. *Science* 216: 633-635.
32. Castle, S.L. and Randall, P.J. 1987. Effects of sulfur deficiency on the synthesis and accumulation of proteins in the developing wheat seeds. *Aust. J. Plant Physiol.* 14: 503-516.
33. Chiment, J.J., Alscher, R. and Hughes, P.R. 1986. Glutathione as an indicator of  $SO_2$ -induced stress in soybean. *Environ. Exp. Bot.* 26: 147-152.
34. Clarkson, D.T., Smith, F.W. and Vanden Berg, P.J. 1983. Regulation of sulphate transport in a tropical legume *Macroptilium atropurpureum*, cv. Sirato. *J. Exp. Bot.* 34: 1463-1483.
35. Cope, D.M. and Spedding, D.J. 1982. Hydrogen sulphide uptake by vegetation. *Atmos. Environ.* 16: 349-352.
36. Cowling, D.W. and Lockyer, D.R. 1978. The effect of  $SO_2$  on *Lolium perenne* L. grown at different levels of sulfur and nitrogen nutrition. *J. Exp. Bot.* 29: 257-265.
37. Cowling, D.W., Jones, L.H.P. and Lockyer, D.R. 1973. Increased yield through correction of sulfur deficiency in ryegrass exposed to sulphur dioxide. *Nature* 243: 479-480.
38. Cowling, D.W. and Koziol, M.J. 1982. Mineral nutrition and plant response to air pollutants. In: *Eff-*

- fects of gaseous air pollution in agriculture and horticulture, Unsworth, M.H. and Ormrod, D.P. eds. pp. 349-375, London: Butterworth Scientific.
39. Cram, W.J., 1983. Sulphate accumulation is regulated at the tonoplast. *Plant Sci. Lett.* 31:329-338.
  40. Cram, W.J., 1983. Characteristics of sulfate transport across plasmalemma and tonoplast of carrot root cells. *Plant Physiol.* 72: 204- 211.
  41. Datko, A.M., Mudd, S.H., Giovanelli, J. and Macnicol, P.K. 1978. Sulfur-containing compounds in *Lemna perpusilla* 6746 grown at a range of sulfate concentrations. *Plant Physiol.* 62: 629-635.
  42. de Cormis, L. 1969. Quelques aspects de l'absorption du soufre par les plants soumises á une atmosphère contenant du SO<sub>2</sub>. In: Air pollution: Proc. 1st eur. congr. influence of air pollut. on plants and animals, pp. 75-78, Wageningen: Pudoc.
  43. De Kok, L.J. 1989. Responses of sulfur metabolism in plants to atmospheric hydrogen sulfide. *Phyton* 29; in press.
  44. De Kok, L.J. and Kuiper, P.J.C. 1986. Effect of short-term dark incubation with sulfate, chloride and selenate on the glutathione content of spinach leaf discs. *Physiol. Plant.* 68: 477-482.
  45. De Kok, L.J. and Graham, M. 1989. Levels of pigments, soluble proteins, amino acids and sulfhydryl compounds in foliar tissue of *Arabidopsis thaliana* during dark-induced and natural senescence. *Plant. Physiol. Biochem.* 27: 203-209.
  46. De Kok, L.J., De Kan, P.J.L., Táncoz, O.G. and Kuiper, P.J.C. 1981. Sulphate-induced accumulation of glutathione and frost-tolerance of spinach leaf tissue. *Physiol. Plant.* 53: 435-438.
  47. De Kok, L.J., Thompson, C.R. and Kuiper, P.J.C. 1983. Sulfide-induced oxygen uptake by isolated spinach chloroplasts catalyzed by photosynthetic electron transport. *Physiol. Plant.* 59: 19-22.
  48. De Kok, L.J., Thompson, C.R., Mudd, J.B. and Kats, G. 1983. Effect of H<sub>2</sub>S fumigation on water-soluble sulfhydryl compounds in shoots of crop plants. *Z. Pflanzenphysiol.* 111: 85-89.
  49. De Kok, L.J., Bosma, W., Maas, F.M. and Kuiper, P.J.C. 1985. The effect of short-term H<sub>2</sub>S fumigation on water-soluble sulphhydryl and glutathione levels in spinach. *Plant, Cell Environ.* 8: 189-194.
  50. De Kok, L.J., Maas, F.M., Godeke, J., Haaksmá, A.B. and Kuiper, P.J.C. 1986. Glutathione, a tripeptide which may function as a temporary storage of excessive reduced sulphur in H<sub>2</sub>S fumigated spinach plants. *Plant Soil* 91: 349-352.
  51. De Kok, L.J., Stulen, I., Bosma, W. and Hibma, J. 1986. The effect of short-term H<sub>2</sub>S fumigation on nitrate reductase activity in spinach leaves. *Plant Cell Physiol.* 27: 1249-1254.
  52. De Kok, L.J., Buwalda, F. and Bosma, W. 1988. Determination of cysteine and its accumulation in spinach leaf tissue upon exposure to excess sulfur. *J. Plant Physiol.* 133: 502-505.
  53. De Kok, L.J., Stahl, K. and Rennenberg, H. 1989. Fluxes of atmospheric hydrogen sulphide to plant shoots. *New Phytol.* 112: 533-542.
  54. Duke, S.H. and Reisenauer, H.M. 1986. Roles and requirements of sulfur in plant nutrition. In: Sulfur in agriculture, Tabatabai, M.A. ed. pp. 123-168. Madison: Am. Soc. Agron.
  55. Dijkshoorn, W. and van Wijk, A.L. 1967. The sulfur requirements of plants as evidenced by the sulphur-nitrogen ratio in the organic matter. A review of published data. *Plant Soil* 26: 129-157.
  56. Ellis, R.J. 1969. Sulphate activation in higher plants. *Planta* 88: 34-42.
  57. Faller, N. 1972. Schwefeldioxid, Schwefelwasserstoff, nitrose Gase und Ammoniak als ausschließliche S- bzw. N-Quellen der höheren Pflanze. *Z. Pflanzenernähr. Düngg. Bodenkd.* 131: 120-130.
  58. Faller, N. 1972. Absorption of sulfur dioxide by tobacco plants differently supplied with sulphate. In: Isotopes and radiation in soil-plant relationships including forestry, pp. 51-57. Vienna: Int. Atom. Energ. Agenc.
  59. Faller, N. and Höfner, W. 1969. Schwefelassimilation durch zerkleinertes Pflanzenmaterial nach <sup>35</sup>SO<sub>2</sub>-Begasung. *Z. Pflanzenernähr. Düngg. Bodenkd.* 121: 111-116.
  60. Faller, N., Herwig, K. and Kühn, H. 1970. Die Aufnahme von Schwefeldioxyd (S<sup>35</sup>O<sub>2</sub>) aus der Luft. I. Einfluss auf den pflanzlichen Ertrag. *Plant Soil* 33: 177-191.
  61. Faller, N., Herwig, K. and Kühn, H. 1970. Die Aufnahme von Schwefeldioxyd (S<sup>35</sup>O<sub>2</sub>) aus der Luft. II. Aufnahme, Umbau und Verteilung in der Pflanze. *Plant Soil* 33: 283-295.
  62. Filner, P., Rennenberg, H., Sekiya, J., Bressan, R.A., Wilson, L.G., Le Cureux, L. and Shimei, T. 1984. Biosynthesis and emission of hydrogen sulfide by higher plants. In: Gaseous air pollutants and plant metabolism, Koziol, M.J. and Whatley, F.R. eds. pp. 291-312. London: Butterworths.
  63. Fowler, D. 1978. Dry deposition of SO<sub>2</sub> on agricultural crops. *Atmos. Environ.* 12: 369-373.
  64. Fowler, D. and Cape, J.N. 1982. Air pollutants in agriculture and horticulture. In: Effects of gaseous air pollution in agriculture and horticulture, Unsworth, M.H. and Ormrod, D.P. eds. pp. 3-26. London: Butterworth Scientific.

65. Fox, R.L. and Blair, G.J. 1986. Plant response to sulfur in tropical soils. In: Sulfur in agriculture, Tabatabai, M.A. ed. pp. 406-434. Madison: Am. Soc. Agron.
66. Frankhauser, H. and Brunold, C. 1978. Localization of adenosine 5'-phosphosulfate sulfotransferase in spinach leaves. *Planta* 143: 285-289.
67. Fukumorita, T. and Chino, M. 1982. Sugar, amino acid and inorganic contents in rice phloem sap. *Plant Cell Physiol.* 23: 273-283.
68. Garsed, S.G. 1984. Uptake and distribution of pollutants in the plant and residence time of active species. In: Gaseous air pollutants and plant metabolism, Koziol, M.J. and Whatley, F.R. eds. pp. 83-103. London: Butterworths.
69. Garsed, S.G. and Read, D.J. 1977. Sulphur dioxide metabolism in soy-bean, *Glycine max* var. biloxi. I. The effects of light and dark on uptake and translocation of  $^{35}\text{SO}_2$ . *New Phytol* 78: 111-119.
70. Garsed, S.G. and Read, D.J. 1977. Sulphur dioxide metabolism in soy-bean, *Glycine max* var. biloxi. II. Biochemical distribution of  $^{35}\text{SO}_2$  products. *New Phytol* 79: 583-592.
71. Garsed, S.G. and Read, D.J. 1977. The uptake and metabolism of  $^{35}\text{SO}_2$  in plants of different sensitivity to sulfur dioxide. *Environ. Pollut.* 13: 173-186.
72. Ghisi, R., Anaclerio, F. and Passera, C. 1986. Effects of nitrogen deprivation on the ATP-sulphurylase and O-acetylserine sulphydrylase activities of mesophyll protoplasts and bundle sheath strands of maize leaves. *Biol. Plant.* 28: 114-119.
73. Gillham, D.J. and Dodge, A.D. 1986. Hydrogen-peroxide-scavenging systems within pea chloroplasts. A quantitative study. *Planta* 167: 246-251.
74. Giovanelli, J., Mudd, S.H. and Datko, A.H. 1980. Sulfur amino acids in plants. In: The biochemistry of plants, Volume 5, Amino acids and derivatives, Miflin, B.J. ed. pp. 454-505. New York: Academic Press.
75. Godzik, S. 1984. Air pollution problems in some central European countries – Czechoslovakia, The German Democratic Republic and Poland. In: Gaseous air pollutants and plant metabolism, Koziol, M.J. and Whatley, F.R. eds. pp. 25-34. London: Butterworths.
76. Godzik, S. and Linskens, H.F. 1974. Concentration changes of free amino acids in primary bean leaves after continuous and interrupted  $\text{SO}_2$  fumigation and recovery. *Environ. Pollut.* 7: 25-38.
77. Godzik, S. and Krupa, S.V. 1982. Effects of sulfur dioxide on the growth and yield of agricultural and horticultural crops. In: Effects of gaseous air pollution in agriculture and horticulture, Unsworth, M.H. and Ormrod, D.P. eds. pp. 247-265. London: Butterworth Scientific.
78. Grill, D. and Esterbauer, H. 1973. Quantitative Bestimmung wasserlöslicher Sulfhydrylverbindungen in gesunden und  $\text{SO}_2$ -geschädigten Nadeln von *Picea abies*. *Phyton* 15: 87-101.
79. Grill, D. and Esterbauer, H. 1973. Cystein and Glutathion in gesunden und  $\text{SO}_2$ -geschädigten Fichtennadeln. *Eur. J. For. Pathol.* 3: 65-71.
80. Grill, D., Esterbauer, H. and Klösch, U. 1979. Effect of sulfur-dioxide on glutathione in leaves of plants. *Environ. Pollut.* 17: 187-194.
81. Grill, D., Esterbauer, H., Scharner, M. and Felgitsch, Ch. 1980. Effect of sulfur-dioxide on protein-SH in needles of *Picea abies*. *Eur. J. For. Path.* 10: 263-267.
82. Grill, D., Esterbauer, H. and Hellig, K. 1982. Further studies on the effect of  $\text{SO}_2$ -pollution on the sulfhydryl-system of plants. *Phytopath. Z.* 104: 264-271.
83. Guderian, R. 1970. Untersuchungen über quantitative Beziehungen zwischen dem Schwefelgehalt von Pflanzen und dem Schwefeldioxidgehalt der Luft. Teil I. *Z. Pflanzenkrankh.* 7: 200-220.
84. Guderian, R. 1970. Untersuchungen über quantitative Beziehungen zwischen dem Schwefelgehalt von Pflanzen und dem Schwefeldioxidgehalt der Luft. Teil II. *Z. Pflanzenkrankh.* 7: 289-308.
85. Guderian, R. 1970. Untersuchungen über quantitative Beziehungen zwischen dem Schwefelgehalt von Pflanzen und dem Schwefeldioxidgehalt der Luft. Teil III. *Z. Pflanzenkrankh.* 7: 387-399.
86. Guderian, R. and Van Haut, H. 1970. Nachweis von Schwefeldioxid: Wirkungen an Pflanzen. *Staub-Reinhalt. Luft* 30: 22-35.
87. Hällgren, J.-E. 1978. Physiological and biochemical effects of sulfur dioxide on plants. In: Sulfur in the environment, part II: ecological impacts, Nriagy, J.O. ed. pp. 163-209, New York: John Wiley & Sons.
88. Hällgren, J.-E. and Fredriksson, S.A. 1982. Emission of hydrogen sulfide from sulfur dioxide-fumigated pine trees. *Plant Physiol.* 70: 456-459.
89. Hällgren, J.-E., Linder, S., Richter, A., Troeng, E. and Granat, L. 1982. Uptake of  $\text{SO}_2$  in shoots of Scots pine: field measurements of net flux of sulphur in relation to stomatal conductance. *Plant Cell Environ.* 5: 75-83.

90. Harrington, H.M. and Smith, I.K. 1980. Cysteine metabolism in cultured tobacco cells. *Plant Physiol.* 65:151-155.
91. Hayashi, H. and Chino, M. 1985. Nitrate and other anions in rice phloem sap. *Plant Cell Physiol.* 26: 325-330.
92. Heath, R.L. 1980. Initial events in injury to plants by air pollutants. *Annu. Rev. Plant Physiol.* 31: 395-431.
93. Heck, W.W. 1984. Defining gaseous pollution problems in North America. In: *Gaseous Air Pollutants and Plant Metabolism*, Koziol, M.J. and Whatley, F.R. eds. pp. 35-55, London: Butterworths.
94. Hill, A.C. 1971. Vegetation: A sink for atmospheric pollutants. *J. Air Pollut. Contr. Ass.* 21: 341-346.
95. Holobradá, M. 1977. The influence of S-deficient pretreatment on sulfur uptake and assimilation by intact maize plants. II. Some aspects of metabolism. *Agrochimica* 21: 478-486.
96. Horsman, D.C. and Wellburn, A.R. 1976. Appendix II. Guide to the metabolic effects of air pollutants on higher plants. In: *Effects of air pollutants on plants*, Mansfield, T.A. ed. pp. 185-199, London: Cambridge University Press.
97. Jäger, H.-J. and Steubing, L. 1970. Fraktionierte Schwefelbestimmung in Pflanzenmaterial zur Beurteilung einer SO<sub>2</sub>-Einwirkung. *Angew. Bot.* 44: 209-221.
98. Jäger, H.-J. and Klein, H. 1976. Modellversuche zum Einfluss der Nährstoffversorgung auf die SO<sub>2</sub>-Empfindlichkeit von Pflanzen. *Eur. J. For. Path.* 6: 347-354.
99. Jäger, H.-J., Bender, J. and Grunhage, L. 1985. Metabolic responses of plants differing in SO<sub>2</sub> sensitivity towards SO<sub>2</sub> fumigation. *Environ. Pollut.* 39: 317-335.
100. Jones, M.B. 1986. Sulfur availability indexes. In: *Sulfur in agriculture*, Tabatabai, M.A. ed. pp. 549-566, Madison: Am. Soc. Agron.
101. Jones, S.L. and Smith, I.K. 1981. Sulfate transport in cultured tobacco cells. Effects of calcium and sulfate concentration. *Plant Physiol.* 67: 445-448.
102. Kaiser, G., Martinoia, E., Schröppel-Meier, G. and Heber, U. 1989. Active transport of sulfate into the vacuole of plant cells provides halotolerance and can detoxify SO<sub>2</sub>. *J. Plant Physiol.* 133: 756-763.
103. Kellogg, W.W., Cadle, R.D., Allen, E.R., Lazrus, A.L. and Martell, E.A. 1972. The sulfur cycle. *Science* 175: 587-596.
104. Kinraide, T.B. and Staley, T.E. 1985. Cysteine-induced H<sub>2</sub>S emission, ATP depletion and membrane electrical responses in oat coleoptiles. *Physiol. Plant.* 64: 271-222.
105. Klapheck, S., Latus, C. and Bergmann, L. 1987. Localization of glutathione synthetase and distribution of glutathione in leaf cells of *Pisum sativum* L. *J. Plant Physiol.* 131: 123-131.
106. Klein, H. and Jäger, H.-J. 1976. Einfluss der Nährstoffversorgung auf die SO<sub>2</sub>-Empfindlichkeit von Erbsenpflanzen. *Z. Pflanzenkrankh. Pflanzenschutz* 83: 555-568.
107. Klein, H., Jäger, H.-J. and Steubing, L. 1974. Einfluss der Schwefel- und Stickstoffversorgung auf die SO<sub>2</sub>-Empfindlichkeit von *Pisum sativum*. *Angew. Bot.* 48: 1-8.
108. Klein H., Jäger, H.-J., Domes, W. and Wong, C.H., 1978. Mechanism contributing to differential sensitivities of plants to SO<sub>2</sub>. *Oecologia* 33: 203-208.
109. Kondo, N., Akiyama, Y., Fujiwara, M. and Sugahara, K. 1980. Sulfite oxidizing activities in plants. *Res. Rep. Nat. Inst. Environ. Studies* 11: 137-150.
110. Koziol, M.J. 1984. Interactions of gaseous pollutants with carbohydrate metabolism. In: *Gaseous air pollutants and plant metabolism*, Koziol, M.J. and Whatley, F.R. eds. pp. 251-273, London: Butterworths.
111. Koziol, M.J., Shelvey, J.D. and Beedham, B., 1986. Uptake of S<sup>IV</sup> anions and the induction of gaseous emissions in leaf segments of SO<sub>2</sub>-sensitive and resistant genotypes of *Lolium perenne* L. *J. Exp. Bot.* 37: 556-571.
112. Krause, G.H.M. 1979. Relative Phytotoxizität von Schwefelwasserstoff. *Staub-Reinhalt. Luft* 39: 165-167.
113. Laisk, A., Pfanz, H., Schramm, M.J. and Heber, U. 1988. Sulfur-dioxide fluxes into different cellular compartments of leaves photosynthesizing in a polluted atmosphere. I. Computer analysis. *Planta* 173: 230-240.
114. Laisk, A., Pfanz, H. and Heber, U. 1988. Sulfur-dioxide fluxes into different cellular compartments of leaves photosynthesizing in a polluted atmosphere. II. Consequences of SO<sub>2</sub> uptake as revealed by computer analysis. *Planta* 173: 241-252.
115. Lauenroth, W.K., Bickel, C.J. and Dodd, J.L. 1979. Sulfur accumulation in western wheatgrass ex-

- posed to three controlled SO<sub>2</sub> concentrations. *Plant Soil* 53: 131-136.
116. Laurence, J.A. and Weinstein, L.H. 1981. Effects of air pollutants on plant productivity. *Annu. Rev. Phytopath.* 19: 257-271.
117. Leone, I.A. and Brennan, E. 1972. Modification of sulfur dioxide injury to tobacco and tomato by varying nitrogen and sulfur nutrition. *J. Air. Pollut. Contr. Ass.* 22: 544-547.
118. Leone, I.A. and Brennan, E. 1972. Sulfur nutrition as it contributes to the susceptibility of tobacco and tomato to SO<sub>2</sub> injury. *Atmos. Environ.* 6: 259-266.
119. Lenzian, K.J. 1984. Permeability of plant cuticles to gaseous air pollutants. In: *Gaseous air pollutants and plant metabolism*, Koziol, M.J. and Whatley, F.R. eds. pp. 77-81, London: Butterworths.
120. Linzon, S.N. 1978. Effects of airborne sulfur pollutants on plants. In: *Sulfur in the environment. Part II: Ecological impacts*, Nriagu, J.O. ed. pp. 109-161, New York: John Wiley & Sons.
121. Maas, F.M. and De Kok, L.J. 1988. *In vitro* NADH oxidation as an early indicator for growth reduction in spinach exposed to H<sub>2</sub>S in the ambient air. *Plant & Cell Physiol.* 29: 523-526.
122. Maas, F.M., De Kok, L.J. and Kuiper, P.J.C. 1985. The effect of H<sub>2</sub>S fumigation on various spinach (*Spinacia oleracea* L.) cultivars. Relation between growth inhibition and accumulation of sulphur compounds in the plant. *J. Plant Physiol.* 119: 219-226.
123. Maas, F.M., De Kok, L.J., Hoffmann, I. and Kuiper, P.J.C. 1987. Plant responses to H<sub>2</sub>S and SO<sub>2</sub> fumigation. I. Effects on growth, transpiration and sulfur content of spinach. *Physiol. Plant.* 70: 713-721.
124. Maas, F.M., De Kok, L.J., Strik-Timmer, W. and Kuiper, P.J.C. 1987. Plant responses to H<sub>2</sub>S and SO<sub>2</sub> fumigation. II. Differences in metabolism of H<sub>2</sub>S and SO<sub>2</sub> in spinach. *Physiol. Plant.* 70: 722-728.
125. Maas, F.M., De Kok, L.J., Peters, J.L. and Kuiper, P.J.C. 1987. A comparative study on the effects of H<sub>2</sub>S and SO<sub>2</sub> fumigation on the growth and accumulation of sulphate and sulphhydryl compounds in *Trifolium pratense* L., *Glycine max* Merr. and *Phaseolus vulgaris* L. *J. Exp. Bot.* 38: 1459-1469.
126. Maas, F.M., Van Loo, E.N. and Van Hasselt, P.R. 1988. Effect of long-term H<sub>2</sub>S fumigation on photosynthesis in spinach. Correlation between CO<sub>2</sub> fixation and chlorophyll *a* fluorescence. *Physiol. Plant.* 72: 78-83.
127. Malhotra, S.S. and Hocking, D. 1976. Biochemical and cytological effects of sulfur dioxide on plant metabolism. *New Phytol.* 76: 227-237.
128. Malhotra, S.S. and Sarkar, S.K., 1979. Effects of sulfur dioxide on sugar and free amino acid content of pine seedlings. *Physiol. Plant.* 47: 223-228.
129. Materna, J. 1966. Die Ausscheidung des durch die Fichtennadeln absorbiertes Schwefeldioxids. *Arch. Forstwesen.* 15: 691-692.
130. Mehlhorn, H., Seufert, G., Schmidt, A. and Kunert, K.J. 1986. Effect of SO<sub>2</sub> and O<sub>3</sub> on production of antioxidants in conifers. *Plant Physiol.* 82: 336-338.
131. Meister, A. 1983. Selective modification of glutathione metabolism. *Science* 220: 472-477.
132. Miller, J.E. and Xerikos, P.B. 1979. Residence time of sulphite in SO<sub>2</sub> 'sensitive' and 'tolerant' soybean cultivars. *Environ. Pollut.* 18: 259-264.
133. Mudd, J.B. 1975. Sulfur dioxide. In: *Responses of plants to air pollution*, Mudd, J.B. and Kozlowski, T.T. eds. pp. 9-22, New York: Acad. Press.
134. Mudd, J.B. 1979. Effects on vegetation and aquatic animals. In: *Hydrogen sulfide*, pp. 67-79, Baltimore: Univ. Park Press.
135. Ng, B. H. and Anderson, J.W., 1978. Chloroplast cysteine synthetases of *Trifolium repens* and *Pisum sativum*. *Phytochem* 17: 879-885.
136. Noggle, J.C., Meagher, J.F. and Jones, U.S. 1986. Sulfur in the atmosphere and its effect on plant growth. In: *Sulfur in agriculture*, Tabatabai, M.A. ed. pp. 251-278, Madison: Am. Soc. Agron.
137. Norby, R.J. and Kozlowski, T.T. 1981. Relative sensitivity of three species of woody plants to SO<sub>2</sub> at high or low temperature. *Oecologia* 51: 33-36.
138. Norby, R.J. and Kozlowski, T.T. 1982. The role of stomata in sensitivity of *Betula papyrifera* seedling to SO<sub>2</sub> at different humidities. *Oecologia* 53: 34-39.
139. Olsen, R.A. 1957. Absorption of sulfur dioxide from the atmosphere by cotton plants. *Soil Sci.* 84: 107-111.
140. Olszyk, D.M. and Tingey, D.T. 1985. Interspecific variation in SO<sub>2</sub> flux. Leaf surface versus internal flux, and components of leaf conductance. *Plant Physiol.* 79: 949-956.
141. Pfanz, H., Martinoia, E., Lange, O.-L. and Heber, U. 1987. Mesophyll resistances to SO<sub>2</sub> fluxes into leaves. *Plant Physiol.* 85: 922-927.

142. Pfanz, H., Martinoia, E., Lange, O.-L. and Heber, U. 1987. Flux of SO<sub>2</sub> into leaf cells and cellular acidification by SO<sub>2</sub>. *Plant Physiol.* 85: 928-933.
143. Rasmussen, K.H., Taheri, M. and Kabel, R.L. 1975. Global emissions and natural processes for removal of gaseous pollutants. *Wat. Air Soil Pollut.* 4: 33-64.
144. Rendig, V.V. 1986. Sulfur and crop quality. In: *Sulfur in agriculture*, Tabatabai, M.A. ed. pp. 635-652, Madison: Am. Soc. Agron.
145. Rendig, V.V., Oputa, C. and McComb, E.A. 1976. Effects of sulfur deficiency on non-protein nitrogen, soluble sugars and N/S ratios in young corn (*Zea mays* L.) plants. *Plant Soil* 44: 423-437.
146. Rennenberg, H. 1981. Differences in the use of cysteine and glutathione as sulfur source in photoheterotrophic tobacco suspension cultures. *Z. Pflanzenphysiol.* 105: 31-40.
147. Rennenberg, H. 1982. Glutathione metabolism and possible biological roles in higher plants. *Phytochemistry* 21: 2771-2781.
148. Rennenberg, H. 1983. Role of O-acetylserine in hydrogen sulfide emission from pumpkin leaves in response to sulfate. *Plant Physiol.* 73: 560-565.
149. Rennenberg, H. 1984. The fate of excess sulfur in higher plants. *Annu. Rev. Plant Physiol.* 35: 121-153.
150. Rennenberg, H. and Filner, P. 1982. Stimulation of H<sub>2</sub>S emission from pumpkin leaves by inhibition of glutathione synthesis. *Plant Physiol.* 69: 766-770.
151. Rennenberg, H. and Filner, P. 1983. Developmental changes in the potential for H<sub>2</sub>S emission by cucurbit plants. *Plant Physiol.* 71: 269-275.
152. Rennenberg, H. and Grundel, I. 1985. Growth and hydrogen sulfide emission of photoheterotrophic tobacco cells supplied with L-cysteine as sole sulfur source. *J. Plant Physiol.* 120: 47-56.
153. Rennenberg, H. and Thoene, B. 1987. The mobility of sulphur in higher plants. In: *Proc. int. symp. elem. sulphur in agric.*, Vol. 2, pp. 701-707. Nice.
154. Rennenberg, H., Sekija, J., Wilson, L.G. and Filner, P. 1982. Evidence for an intracellular sulfur cycle in cucumber leaves. *Planta* 154: 516-524.
155. Rennenberg, H., Reski, G. and Polle, A. 1983. Hydrogen sulfide emission by cultured tobacco cells. *Z. Pflanzenphysiol.* 111: 189-202.
156. Rennenberg, H., Arabatzis, N. and Grundel, I. 1987. Cysteine desulhydrase activity in higher plants: evidence for the action of L- and D-cysteine specific enzymes. *Phytochemistry* 26: 1583-1589.
157. Rennenberg, H., Polle, A., Martini, N. and Thoene, B. 1988. Interaction of sulfate and glutathione transport in cultured tobacco cells. *Planta* 176: 68-74.
158. Rennenberg, H., Huber, B., Schröder, P., Stahl, K., Haunold, W., Georgii, H.-W., Slovik, S. and Pfanz, H. 1990. Emission of volatile sulfur-compounds from spruce trees. *Plant Physiol.* in press.
159. Reuveny, Z. and Filner, P. 1977. Regulation of adenosine triphosphate sulfurylase in cultured tobacco cells. Effects of sulfur and nitrogen sources on the formation and decay of the enzyme. *J. Biol. Chem.* 252: 1858-1864.
160. Reuveny, Z., Dougall, D.K. and Trinity, P. 1980. Regulatory coupling of nitrate and sulfate assimilation pathways in cultured tobacco cells. *Natl. Acad. Sci. USA* 77: 6670-6672.
161. Schiff, J.A. and Hodson, R.C. 1973. The metabolism of sulfate. *Annu. Rev. Plant Physiol.* 24: 381-414.
162. Schmidt, A. 1982. A cysteine desulhydrase from spinach leaves specific for D-cysteine. *Z. Pflanzenphysiol.* 107: 301-312.
163. Schmutz, D. and Brunold, C. 1982. Regulation of sulfate assimilation in plants. XIII. Assimilatory sulfate reduction during ontogenesis of primary leaves of *Phaseolus vulgaris* L. *Plant Physiol.* 70: 524-527.
164. Sekiya, J., Wilson, L.G. and Filner, P. 1982. Resistance to injury by sulfur dioxide. Correlation with its reduction to, and emission of hydrogen sulfide in Cucurbitaceae. *Plant Physiol.* 70: 437-441.
165. Sekiya, J., Schmidt, A., Wilson, L.G. and Filner, P. 1982. Emission of hydrogen sulfide by leaf tissue in response to L-cysteine. *Plant Physiol.* 70: 430-436.
166. Sekiya, J., Schmidt, A., Rennenberg, H., Wilson, L.G. and Filner, P. 1982. Hydrogen sulfide emission by cucumber leaves in response to sulfate in light and dark. *Phytochemistry* 21: 2173-2178.
167. Shevyakova, N.I. 1968. Rate of hydrogen sulfide formation in plants under salinization conditions. *Sov. Plant Physiol.* 15: 912-914.
168. Silvius, J.E., Baer, C.H., Dodrill, S. and Patrick, H. 1976. Photoreduction of sulfur dioxide in spinach leaves and isolated chloroplasts. *Plant Physiol.* 57: 799-801.
169. Slatt, B.J., Natusch, D.F.S., Prospero, J.M. and Savoie, D.L. 1978. Hydrogen sulfide in the at-

- mosphere of the northern equatorial atlantic ocean and its relation to the global sulfur cycle. *Atm. Environ.* 12: 981-991.
170. Smith, I.K. 1975. Sulfate transport in cultured tobacco cells. *Plant Physiol.* 55: 303-307.
  171. Smith, I.K. 1980. Regulation of sulfate assimilation in tobacco cells. Effect of nitrogen and sulfur nutrition on sulfate permease and O-acetylserine sulphydrylase. *Plant Physiol.* 66: 877-883.
  172. Smith, I.K., 1981. Compartmentation of sulfur metabolites in tobacco cells. Use of efflux analysis. *Plant Physiol.* 68: 937-940.
  173. Smith, I.K., Kendall., A.C., Keys, A.J., Turner, J.C. and Lea, P.J. 1985. The regulation of the biosynthesis of glutathione in leaves of Barley (*Hordeum Vulgare* L.). *Plant Science* 41: 11-17.
  174. Spálený, J. 1977. Sulfate transformation to hydrogen sulphide in spruce seedlings. *Plant. Soil* 48: 557-563.
  175. Spálený, J., Kutáček, M. and Oplistolová, K. 1965. On the metabolism of  $S^{35}O_2$  in the leaves of cauliflower (*Brassica oleracea* var. *Botrytis* L.) *Int. J. Air. Water Pollut.* 9: 525-530.
  176. Steubing, L. 1979. Wirkung von Schwefelwasserstoff auf höhere Pflanzen. *Staub-Reinhalt. Luft* 39: 161-164.
  177. Steubing, L. and Jäger, H.-J. 1978. Oekophysiologisch-biochemische Wirkung von  $H_2S$  auf *Pisum sativum* L. *Angew. Bot.* 52: 137-147.
  178. Stewart, B.A. and Porter, C.K. 1969. Nitrogen sulfur relationships in wheat (*Trifolium pratense* L.), corn (*Zea mays*), and beans (*Phaseolus vulgaris*). *Agron. J.* 61: 267- 271.
  179. Stratigakos, A. and Ormrod, D.P. 1985. Response of tomato to sulphur nutrition and  $SO_2$ . *Water Air Soil Pollut.* 24: 19-26.
  180. Takemoto, B.K., Noble, R.D. and Harrington, H.M. 1986. Differential sensitivity of duckweeds (*Lemnaceae*) to sulphite. II. Thiol production and hydrogen sulphide emission as factors influencing sulphite phytotoxicity under low and high irradiance. *New Phytol.* 103: 541-548.
  181. Taylor, Jr., G.E. and Tingey, D.T. 1983. Sulfur dioxide flux into leaves of *Geranium carolinianum* L. Evidence for a non stomatal or residual resistance. *Plant Physiol.* 72: 237-244.
  182. Taylor, Jr., G.E., McLaughlin, S.B., Shriner, D.S. and Selvidge, W.J. 1983. The flux of sulfur containing gases to vegetation. *Atmos. Environ.* 17: 789-796.
  183. Taylor, Jr., G.E., Selvidge, W.J. and Crumbley, I.J. 1985. Temperature effects on plant response to sulfur dioxide in *Zea mays*, *Liriodendron tulipifera*, and *Fraxinus pennsylvanica*. *Water, Air, Soil Pollut.* 24: 405-418.
  184. Thoiron, A., Thoiron, B., Demarty, M. and Thellier, M. 1981. Compartmental analysis of sulphate transport in *Lemna minor* L., taking plant growth and sulphate metabolism into consideration. *Biochim. Biophys. Acta* 644: 24-35.
  185. Thomas, M.D. 1951. Gas damage to plants. *Annu. Rev. Plant Physiol.* 2: 293-322.
  186. Thomas, M.D. 1958. Assimilation of sulfur and physiology of essential S-compounds. In: *Handbuch der Pflanzenphysiologie, Vol IX, Der Stoffwechsel der schwefel- und phosphorhaltigen Verbindungen*, ed. P. Schwarze, pp. 37-63. Berlin: Springer-Verlag.
  187. Thomas, M.D., Hendricks, R.H. and Hill, G.R. 1944. Some chemical reactions of sulfur dioxide after absorption by alfalfa and sugar beets. *Plant Physiol.* 19: 212-226.
  188. Thomas, M.D., Hendricks, R.H., Bryner, L.C. and Hill, G.R. 1944. A study of the sulphur metabolism of wheat, barley and corn using radioactive sulphur. *Plant Physiol.* 19: 227-244.
  189. Thompson, C.R. and Kats, G. 1978. Effect of continuous  $H_2S$  fumigation on crop and forest plants. *Environ. Sci. Technol.* 12: 550-553.
  190. Tisdale, S.L., Reneau, Jr., R.B. and Platou, J.S. 1986. Atlas of sulfur deficiencies. In: *Sulfur in agriculture*, Tabatabai, M.A. ed. pp. 295- 323, Madison: Am. Soc. Agron.
  191. Trudinger, P.A. 1986. Chemistry of the sulfur cycle. In: *Sulfur in agriculture*, Tabatabai, M.A. ed. pp. 1-22, Madison: Am. Soc. Agron.
  192. Tschanz, A., Landolt, W., Beuler, P. and Brunold, C. 1986. Effect of  $SO_2$  on the activity of adenosine 5'-phosphosulfate sulfotransferase from spruce trees (*Picea abies*) in fumigation chambers and under field conditions. *Physiol. Plant.* 67: 235-241.
  193. Unsworth, M.H. 1982. Exposure to gaseous pollutants and uptake by plants. In: *Effects of gaseous air pollution in agriculture and horticulture*, Unsworth, M.H. and Ormrod, D.P. eds. pp. 43-63, London: Butterworth Scientific.
  194. Unsworth, M.H., Biscoe, P.V. and Black, V. 1976. Analysis of gas exchange between plants and polluted atmospheres. In: *Effects of air pollutants on plants*, Mansfield, T.A. ed. pp. 5-16, London: Cambridge University Press.



195. Van Dijk, P.J., Stulen, I. and De Kok, L.J. 1986. The effect of sulfide in the ambient air on amino acid metabolism of spinach leaves. pp. 207-209. In: Physiological, ecological and agricultural aspects of nitrogen metabolism in higher plants, Lambers, H., Neeteson, J.J. and Stulen, I. eds. pp. 207-209, Dordrecht: Martinus Nijhoff Publ.
196. Von Arb, C. and Brunold, C. 1980. Analysis of the regulation of adenosine 5'-phosphosulfate sulfotransferase activity in *Lemna minor* L. using  $^{15}\text{N}$ -density labeling. *Planta* 149: 355-360.
197. Von Arb, C. and Brunold, C. 1985. Ferredoxin-sulfite reductase and ferredoxin-nitrite reductase activities in leaves of *Pisum sativum*: changes during ontogeny and in vitro regulation by sulfide. *Physiol. Plant.* 64: 290-294.
198. Von Arb, C. and Brunold, C. 1986. Enzymes of the assimilatory sulfate reduction in leaves of *Pisum sativum*: activity changes during ontogeny and in vivo regulation by  $\text{H}_2\text{S}$  and cyst(e)ine. *Physiol. Plant.* 67: 81-86.
199. Weigl, J. and Ziegler, H. 1962. Die räumliche Verteilung von  $^{35}\text{S}$  und die Art der markierten Verbindungen in Spinatblättern nach Begasung mit  $^{35}\text{SO}_2$ . *Planta* 58: 435-447.
200. Wilson, L.G., Bressan, R.A. and Filner, P. 1978. Light dependent emission of hydrogen sulfide from plants. *Plant Physiol.* 61: 184-189.
201. Winner, W.E., Smith, C.L., Koch, G.W., Mooney, H.A., Bewley, J.E. and Krause, H.R. 1981. Rates of emission of  $\text{H}_2\text{S}$  from plants and patterns of stable sulphur isotope fractionation. *Nature* 289: 672-673.
202. Wyss, H.-R. and Brunold, C. 1979. Regulation of adenosine 5'-phosphosulfate sulfotransferase activity by  $\text{H}_2\text{S}$  and cyst(e)ine in primary leaves of *Phaseolus vulgaris* L. *Planta* 147: 37-42.
203. Wyss, H.-R. and Brunold, C. 1980. Regulation of adenosine 5'-phosphosulfate sulfotransferase by sulfur dioxide in primary leaves of beans (*Phaseolus vulgaris*). *Physiol. Plant.* 50: 161-165.
204. Ziegler, I. 1975. The effect of  $\text{SO}_2$  pollution on plant metabolism. *Residue Rev.* 56: 79-105.
205. Ziegler, I. 1977. Subcellular distribution of  $^{35}\text{S}$ -sulfur in spinach leaves after application of  $^{35}\text{SO}_4^{2-}$ ,  $^{35}\text{SO}_3^{2-}$ , and  $^{35}\text{SO}_2$ . *Planta* 135: 25-32.

# ECOLOGICAL ASPECTS OF SULFUR METABOLISM

Wilfried H.O. Ernst

*Department of Ecology and Ecotoxicology, Biological Laboratory, The Free University, De Boelelaan 1087, 1081 HV Amsterdam, The Netherlands*

## Contents

Introduction	131
Accumulation of sulfates	132
Avoidance of sulfur accumulation by elimination of the sulfur compound	133
– Sulfur elimination by salt glands	133
– Biogenic sulfur emission	133
Sulfur compounds as a defence against heterotrophic organism	136
– Resistance to pathogenic fungi	136
– Sulfur compounds as repellants and attractants of herbivores	136
Sulfur compounds and heavy metals	138
Conclusion	139
Acknowledgement	139
Literature cited	139

## Introduction

Sulfur, a macronutrient for all plants, is not uniformly distributed in the environment and soils can show a wide range of concentrations. In addition to the variability of the total sulfur concentration, the chemical form of sulfur can vary from the highly oxygenated state sulfate to the reduced state of sulfide, so that plants surviving and reproducing at the different sites have to have become adapted to the concentration and the speciation of sulfur. Sites with high sulfur availability via the pedosphere are the solfataras (106), gypsum-bearing soils (8, 25), soils on ore outcrops (27, 30) and waterlogged soils (53); the latter will also affect the availability of other nutrients (82, 96). Sulfur enrichment in the hydrosphere occurs in all saline environments (4, 29) and in the atmosphere, either naturally in the vicinity of volcanoes and burning lignite deposits (50), or man-made in all industrialized areas (101). Except for sulfur-deficient crops (5), plants in all other ecosystems seem to be adequately supplied with sulfur or have to cope with an excess. Therefore, the natural concentration of total sulfur in plant leaves, the most useful indicator of sulfur supply, ranges from 0.3% to 7.6%, the latter value found in plants on gypsum soils (25) and nearly 1% higher than the maximum nitrogen concentration in the nitrophilous herb *Anthriscus sylvestris* (55). Therefore, agriculturally defined determinations of the sulfur nutrition status of a plant, *i.e.* total sulfur concentration  $\times$  0.025 total nitrogen concentration (22)

*Sulfur Nutrition and Sulfur Assimilation in Higher Plants*

*edited by H. Rennenberg et al., pp. 131–144*

©1990 SPB Academic Publishing bv, The Hague, The Netherlands

are not relevant for most wild plants. The same statement can be made for estimations of the sulfur status of soils (5).

In addition to the function of sulfur in biomembranes, protein structures and enzyme-catalyzed reactions (see the other contributions in this book), ecological aspects of sulfur range from its role in the water economy of the plant's vacuole (10, 47, 84, 93), in the regulation of pollen incompatibility (19), in aspecific stress reactions to metal surplus (41, 65, 104, 114, 115) to its function in deterrent compounds against herbivores and pathogens (77, 89). As a consequence of a high exposure to certain sulfur forms, plant species may evolve sulfur-resistant genotypes, which can cope with the surplus either by avoidance (24, 66, 101-103) or real tolerance (31).

### Accumulation of sulfates

The seasonal variation of sulfate mineralization from organic matter in aerated soils (15, 80, 99) and varying availability of nitrogen, phosphorus and sulfur independently, to plants (74) may hamper a regular balanced supply of nutrients to the plants. Therefore, storage of these nutrients in the plant may help to avoid short-term shortage, if appropriately compartmentalized. In many ecosystems, sulfate is the common form of sulfur storage in the plant's vacuole. In Central European forests as well as in African miombo woodland, the sulfate uptake by plants appears to be sufficient for requirement, as the sulfate concentration in vacuoles increases from the young leaf stage in spring up to senescence in summer and autumn (28, 84). In contrast to the retranslocation of phosphorus and nitrogen from senescent leaves to living organs, sulfate like chloride remains in the senescent leaves. When glycophytes and halophytes are exposed to sulfate in the rooting medium, sulfate concentrations remain low in the vacuole (2-14% of total sulfur content) as long as the supply is low, but strongly increase at high external supply, in coastal halophytes up to 93% of total sulfur (18 g S kg<sup>-1</sup> dry wt.) (93, 111). Sulfate can contribute to the maintenance of the osmotic potential in plants of coastal dunes and salt marshes by 42% under field conditions (47) and up to 65% under laboratory conditions (93). In the extreme sulfur-enriched environment of gypsum-bearing soils, more than 50% of the sulfur is stored in the plants as sulfate, if the total sulfur concentration exceeds 3% (7, 9). In the gypsophilous plant *Moricandia arvensis* (Brassicaceae) even 92% of total plant sulfur has been found as sulfate. Such a preference for sulfate storage occurs even in glucosinolate-synthesizing plants. Up to now, two exceptions have been found to this rule: *Launea angustifolia* (Asteraceae) with more than 25% of its sulfur as organic sulfur compound, probably flavonoid-sulfate (9) and the saltmarsh grass *Spartina anglica* with up to 50% of its total sulfur as dimethylsulfoniopropionate (110).

Ecologically very interesting compounds are the flavonoid sulfates (45, 46). With the exception of the sulfated cinnamic glucosides in many ferns belonging to the genera *Adiantum* as well as *Ceterach officinarum* and *Pteridium aquilinum* (16, 52), it is obvious that the occurrence of flavonoid sulfates is frequently related to saline habitats or wetlands, *i.e.* sulfur-enriched environments (46, 105). As demonstrated for *Zostera*, plants supplied with radioactive sulfate can allocate 50% of it to 4 flavonoid monosulfates and one flavonoid disulfate within 36 hours (46). Consequently,

Harborne (46) has suggested that flavonoid sulfate is a possible route for inactivation or storage of excessive sulfate. There is another ecologically interesting aspect involved. Flavonoid sulfates occur in nearly all salt-excreting dicotyledonous halophytes, *i.e.* *Armeria*, *Frankenia*, *Limonium*, and *Tamarix*. The balance between sulfate accumulation and sulfate secretion may possibly be more readily achieved metabolically if the sulfate destined for the vacuoles is bound to a larger molecule via phenol sulfotransferase (113). Additional experiments with salt-secreting halophytes may help to elucidate the diversification of the accumulation and secretion route and may establish quantitative data for the ratio between sulfate ions and flavonoid sulfates. Another ecological function of flavonoid sulfates may be their involvement in the absorption of UV-B radiation, which is very high in coastal environments.

### Avoidance of sulfur accumulation by elimination of the sulfur compound

Due to the limitation of cellular storage capacity (7, 27) the cell can either export sulfur to other cells and plant parts or try to eliminate it by excretion via glandular systems, by volatilization or by root exudation. The latter aspect has scarcely been investigated, although excretion of sulfated thioglucosides by crucifer roots (112) and propenylcysteine sulfoxide by onion roots (51) possibly indicate an ecological function as a deterrent to phytophagous nematodes and other soil inhabiting heterotrophs.

#### *Sulfur elimination by salt glands*

Although salt glands have a very restricted distribution in higher plants, there is an aggregation of salt-secreting species in saline environments. The analysis of the secreted salts has not usually included the sulfates (60, 91) or this has only been carried out in a qualitative manner (117). Salts excreted by *Limonium* and *Tamarix* species can contain up to 56% sulfate (6, 20). In experiments with *Limonium vulgare* and *Spartina anglica* it has been demonstrated that an increase of the external sulfate concentration (up to 20 mmol  $\text{Na}_2\text{SO}_4 \text{ l}^{-1}$ ) can stimulate the sulfate secretion up to 24-fold (111). The daily excretion of sulfate may be as high as 0.15% of total leaf sulfur. With a further increase of external sulfate however, salt secretion remains at the same level (12 nmol  $\text{SO}_4^{2-}$  per  $\text{cm}^2$  leaf per day) in *Limonium vulgare* or does not increase with external exposure in the case of *Spartina anglica* (56 nmol  $\text{SO}_4^{2-}$  per  $\text{cm}^2$  leaf per day). These values are a factor of 6 (*S. anglica*) and 14 (*L. vulgare*) lower than the data for the NaCl-secretion of these halophytes (91) and are achieved at lower external salt concentrations.

#### *Biogenic sulfur emission*

Emission of volatile sulfur compounds has been a well-known phenomenon in plant ecology for more than a century. The identification of the compounds concerned, quantification of the process and metabolic pathways involved, however, result from research during the last two decades. Since the first observation of hydrogen sulfide emission by higher plants after exposure to sulfur dioxide (18) and of dimethyl sulfide by marine algae (13) it became evident that plant species can use volatile sulfur com-

pounds in the regulation of their sulfur budget, irrespective of the external sulfur speciation.

When considering the emission of hydrogen sulfide, a light dependent process (119), it should be noted that the present information is based on a limited selection of plant species: the cereal *Zea mays* (119), the herbs *Cucumis* spp., *Cucurbita pepo*, *Glycine max*, *Gossypium hirsutum*, *Lemna* spp., *Spinacia oleracea* and *Spirodela polyrrhiza* (34, 86, 88, 94, 95, 100, 119), and the coniferous trees *Picea abies* and *Pinus sylvestris* (18, 44, 97). The concentrations emitted range from 0.06 up to 2530  $\mu\text{mol H}_2\text{S kg}^{-1}$  dry wt.  $\text{h}^{-1}$  (Table 1). When the experimental conditions are reduced to ecologically realistic situations, the upper range is drastically reduced to 8.5  $\mu\text{mol H}_2\text{S kg}^{-1}$  dry wt.  $\text{h}^{-1}$ . A comparison of these data with those from a number of crops under field conditions demonstrates that the emission rate under natural conditions is diminished to 1 ‰ from that of mature cucumber leaves under laboratory conditions, with a range from 0.08 to 0.2  $\mu\text{mol H}_2\text{S kg}^{-1}$  dry wt.  $\text{h}^{-1}$ . The lack of information of the total sulfur content, however, makes it impossible to judge the efficiency of the system.

Although a number of authors (34, 120) have related these laboratory data to a global sulfur budget, it has no ecological relevance. There is no data at all from the dominant vegetation types of the world such as (a) broad-leaved trees from all climatic regions, (b)  $\text{C}_3$ -grasses and sedges (either wild or cultivated) and (c) plant species with other sulfur sinks such as glucosinolates and sulfoxides. Due to the impact of the environmental sulfur concentration on the  $\text{H}_2\text{S}$  emission rate, it is very important to investigate those plant species which grow in partly or permanently waterlogged soils, e.g. rice and sedges, and to relate the  $\text{H}_2\text{S}$  emission rates to the variation of sulfur availability in non-waterlogged temperate and tropical soils (15, 73, 80). At present the data set is too small to estimate the importance of  $\text{H}_2\text{S}$  emissions for both the individual plant (lack of data on total sulfur concentration and sulfur flux) and for the global sulfur budget.

Another emission compound is dimethyl sulfide (DMS), derived from various sources of organic sulfur metabolites. In marine ecosystems dimethylsulfoniopropionate (DMSP) was the first sulfonium compound isolated from the marine alga *Poly-siphonia fastigiata* (13), but was later found to be widespread in marine plankton and macro-algae (1, 11, 22, 27, 85, 118). DMSP seems to be the most important S-emission source (98). In higher plants, however, this compound seems to be restricted to the salt marsh grass species *Spartina anglica* and *S. alterniflora* (64, 108, 111). Its reported occurrence in *Zostera marina* (39) can not be confirmed (109) and should be attributed to material contaminated with marine epiphytic algae (J. Gorham in 108). The role of DMSP may be that of a compatible solute (121) and/or that of a storage compound for excessive sulfur (49). A critical reexamination of these functions by Van Diggelen (111) has demonstrated that DMSP in *Spartina anglica* makes up between 15 and 36% of the total leaf sulfur, even under non-saline conditions. Increasing concentrations of sodium chloride (up to 500  $\text{mmol l}^{-1}$  solution) or sodium sulfate (up to 50  $\text{mmol l}^{-1}$ ) could not influence the DMSP concentration. Thus, these data provide little evidence for the theory that DMSP operates as a compatible compound in the cytoplasm of this halophyte. The claim for this function as a long-term adaptation to osmotic stress in *Enteromorpha intestinalis* (27) is biased by its

Table 1. Emission of hydrogen sulfide by plants under experimental conditions and their ecological relevance.

Plant species	Emission rate ( $\mu\text{mol H}_2\text{S/kg/h}$ )	Sulfur concentration in test condition	Sulfur speciation	Ref. Ecological relevance
<i>Cucumis sativus</i>				
young leaf	2530 <sup>a</sup>	maximum estimation	sulfur dioxide	94 unrealistic
mature leaf	235 <sup>a</sup>	of 1000 $\mu\text{mol m}^{-3}$ air		
<i>Lemna gibba</i>	0.06–0.39	10–20 mmol water	sulfite	100 present, if anoxic water
<i>Lemna valdiviana</i>	0.32–0.94			
<i>Glycine max</i>	2.11–8.45	0.04–1 $\mu\text{mol water}$	Na-sulfate	120 present
<i>Picea abies</i>	0.07	250 mmol water	K-sulfate	97 unrealistic
3yr seedling				
<i>Pinus sylvestris</i>	0.79	29.7 $\mu\text{mol m}^{-3}$ air	sulfur dioxide	44 unrealistic
3yr seedling				
<i>Pinus sylvestris</i>	5.28–21.1	1.6–6.2 $\mu\text{mol m}^{-3}$ air	sulfur dioxide	44 present only in polluted areas
15–25yr trees				
<i>Phaseolus</i> sp.	0.08–0.2	unknown	probably sulfate	34 unrealistic

<sup>a</sup> assuming 90% water content in fresh material.

determination on a fresh weight basis, which is not a reliable parameter if the plant is water-stressed. The strong accumulation of DMSP by *Spartina anglica* under reduced sulfur conditions (108), together with an increase in total sulfur content, supports evidence that (a) DMSP may indeed serve as a sulfur storage at sulfur excess and (b) the uptake of sulfide (12) is essentially higher than that of metabolically regulated sulfate. This high uptake of sulfide questions the efficiency of the radial oxygen loss of the roots (2).

DMSP is not thought to be a very stable form of sulfur storage, but may contribute to sulfur resistance by volatilization with a turnover of 0.8% total leaf DMSP per day (17). It may degrade by an enzymatically catalyzed cleavage of DMSP into dimethyl sulfide and acrylate (11, 17), mainly in the leaves from which DMS is emitted (17). Therefore, sites on which *Spartina alterniflora* grow have the highest biogenic sulfur emission, a factor 10 to 100 greater than emissions from inland soils and from oceans (98). Unvegetated salt marsh soils, however, have no evolution of DMS (17), or lose their DMS emission within 1 to 3 days after removal of the vegetation (32). The 60-fold increase of summer DMS flux over winter flux (107) indicates that volatilization of DMSP by *Spartina* species and marine algae may be an efficient mechanism of sulfur tolerance via cellular avoidance. Whether or not the recently proposed second degradation route of DMSP via sequential demethylation to 3-mercaptopropionate (57) also occurs in *Spartina* or is only a small bypass of the methionine-DMSP route (72), will demand further research.

Emission of DMS is not restricted to the saline environment. It can also be released from leaves of *Allium cepa*, with 5-methyl-methionine as precursor (48). If this applies to other *Allium* species as well, woodlands in which *Allium ursinum* predominates in the herb layer may then be ecosystems with an important DMS emission. Furthermore, in remote areas of Canada, DMS from boreal wetlands can ac-

count for up to 30 percent of the acidifying sulfur burden (81). If this DMS is emitted by higher plants, it will indicate that regulation of the sulfur budget in wetland plants, invariably growing under strongly reduced sulfur conditions and thus at high  $H_2S$  conditions (122), may occur via volatilization (58).

### Sulfur compounds as a defence against heterotrophic organism

Of the various organic sulfur compounds in plants (58) which play a role in plant-heterotroph relationships, most attention has been paid to the glucosinolates, which are widespread throughout the plant families *Brassicaceae*, *Capparaceae*, *Moringaceae* and *Resedaceae* and restricted to a number of species of the *Amaryllidaceae*, *Caricaceae*, *Limnanthaceae*, *Mimosaceae* and *Tropaeolaceae* (36, 58, 59). As in other plant defense systems against heterotrophs, e.g. cyanogenic glucosides (56), the defense system comes into operation following tissue damage, so that the glucosinolates can be hydrolyzed by the endogenous enzyme, thioglucoside glucohydrolase (EC 3.2.3.1., myrosinase) yielding mainly nitrile, isothiocyanate, and thiocyanate (70). Therefore it is quite reasonable to suppose that the substrate and enzyme are located in different cell compartments. By analogy with the compartmentalisation of alliin alkyl sulfonate lyase (EC 4.4.1.4.) in the vacuole and alkyl cystein sulfoxides in the cytoplasm of bulbs of *Allium cepa* (62), a similar distribution may be present for the glucosinolate defense system (54, 83), although this has yet to be proven. From an evolutionary point of view it is very interesting to note that substrate and enzyme may occur in neighbouring compartments, whereas in the cyanogenic defense system the substrate (linamarin) is located in the vacuole and the enzyme (linamarase, EC 3.2.1.21) in the matrix of the cell wall (56).

### Resistance to pathogenic fungi

Plant species of the *Brassicaceae* are frequently hosts to phytopathogenic fungi, especially those affecting roots and leaves. Although the antifungal activity of volatile isothiocyanate had already been elaborated by the late 1960s (23), it was demonstrated only a decade ago that glucosinolates are used by higher plants as defense compounds against pathogens. It turned out that only those seedlings of wild cabbage (*Brassica oleraceae* ssp. *oleracea*) and cabbage cultivars which surpassed a threshold level of 450  $\mu\text{g}$  allyl isothiocyanate per g dry weight (40) were resistant to cabbage downy mildew (*Peronospora parasitica*). Recently another effective plant-pathogen-defense system has been found for oilseed rape (*Brassica napus* ssp. *oleifera*) and the stem cancer disease, caused by *Leptosphaeria maculans* (77, 78). In this case, resistant plants also had a high level of alkenyl glucosinolate. Such a defense system based on the quantity of the compound can only remain in a population if a high degree of genetic variability is present, and the metabolic costs are compensated by increased survival and reproductive fitness.

### Sulfur compounds as repellants and attractants of herbivores

Glucosinolate may act as a repellant to herbivores if the concentration is sufficiently high. In the case of *Brassica oleraceae* ssp. *oleracea*, it has been shown that a high con-

Table 2. Biosynthetic costs of various defense substrates in higher plants. Data condensed from (14).

Defense system	ATP	NADH <sub>2</sub>	Glucose	Main occurrence
AMHA (2-amino-4-methylhex-4-enoic acid)	0	1	0.5	Hippocastanaceae
Cyanogenic glucosides	2	1	1	Fabaceae
Glucosinolates	12	5	1	Brassicaceae

centration of allyl-isothiocyanate is necessary for the protection of seedlings against the mollusc *Arion ater* and *Agrilolimax reticulatus* (75). Livestock, however, does not seem to be repelled by the taste although damage to thyroid, liver, and kidney is common after consumption of food containing large quantities of glucosinolate (112). As in most ecological defense systems, there are also organisms which have coevolved. Volatile sulfur compounds can consequently act as attractants for phytophagous insects (116). Allyl isothiocyanate attracts a number of crucifer-feeding insect species, e.g. the flea beetles *Phyllotreta* (33), the cabbage root fly *Delia brassicae* (35), the diamond back moth *Plutella maculipennis*, the pollen predating beetle *Megilothus aeneus* (37, 43) and the white butterflies *Pieris brassicae* and *P. napi* (76). In the case of *Pieris* species, butterflies evidently select those plants for oviposition which release the highest quantity of allyl-nitrile. The most remarkable aspect of this coevolution is the lack of any benefit for the plant, because none of the above-mentioned species is involved in flower pollination.

A similar coevolution is reported for onions, where the formation of sulfides from S-propenylcysteine sulfoxide attracts damaging insects such as the onion maggot *Delia antiqua* (51). The maintenance of such a weak defense system has been explained by Rhoades and Cates (89) as having a dual function. They argued that glucosinolates operate as a qualitative defense against unadapted herbivores and as quantitative defenses against adapted insect herbivores. Glucosinolate profiles and concentrations in crucifer plants may be an excellent experimental system to indicate how selection is balancing.

A comparison of the biosynthetic costs of various defense substrates (14) revealed that glucosinolates synthesis costs the most (Table 2). Scaling benefit against the costs demands a comparison of the fitness of plants being polymorphic for glucosinolates, so that the chemical variation between individuals in a population and between populations can be related to variability in susceptibility to heterotroph attack. Variation of glucosinolate concentration between populations can vary two- to three-fold (68, 69, 79, 90). In addition to the total concentration, neighbouring populations of *Brassica napa* in Algeria differed in the various glucosinolate compounds varying from a dominance of gluconapin (88% of all glucosinolates) to a nearly equal proportion of gluconapin and glucobrassicin (79). In the Rocky Mountain bittercress *Cardamine cordifolia*, glucosinolate concentrations proved to be sensitive to environmental stress (flooding, irradiance, temperature) and to developmental changes (67-69). The latter aspect has also been shown for sulfoxides in onions (63). Phenotypic plasticity and genetic variability are the preconditions for a balancing selection. It will be the local environment including the heterotrophic species assemblage which will govern the outcome of this selection (Table 3). Therefore, I do not agree with the statement



Table 3. Evolutionary balance of glucosinolate content in plants.

Glucosinolate content	Advantage	Disadvantage
High	Defense against pathogens Repellent of non-adapted herbivores	Feeding attractant and stimulant to adapted insects no vesicular-arbuscular mycorrhiza (VAM)
Low	Feeding repellent of adapted herbivores VAM (?)	Sensitivity to pathogens Sensitivity to non-adapted herbivores

made by Mithen et al. (79) that *per se* "the current policy of eliminating glucosinolates from oil seed rape is unwise".

### Sulfur compounds and heavy metals

The remaining question concerns the role of sulfur in the contribution to metal resistance in plants, differentiated in the compartmentation of zinc and nickel in the vacuoles (27, 71, 92) and of copper and cadmium in the cytoplasm (65, 114, 115). Zinc-tolerant populations of *Thlaspi alpestre* (= *T. coerulescens*) at Le Bleymard (Cevennen, F) and at Silberberg (FRG) contained 50% to 250% more glucosinolates than the zinc-sensitive populations of the Vosges (71); a similar difference was found between the nickel-tolerant *Alyssum bertolonii* and the nickel-sensitive *Alyssum argenteum* (Table 4). In all species and populations, however, the glucosinolate concentration decreased by 20% with an increase of the metal concentration in the nutrient solution (92). This decrease is in good agreement with results reported from cell-free extracts of *Lepidium sativum* showing an inhibition of sulfotransferase activity by 63% at the presence of 1 mM Zn concentration (38). Therefore, it should not be related to a mobilization of the glucosinolate pool for nickel-complexing agents, as suggested by Sasse (92). The high concentration of glucosinolates in metallophytes belonging to the Brassicaceae may not primarily function against leaf herbivores, being already killed by the high metal concentration (30), but as defense against pathogenic fungi.

Phytochelatin (41) were primarily suggested to be an important compound for the detoxification of all heavy metals. Recent findings, however, show that the synthesis of phytochelatin (41, 104) and other metal binding peptides (65, 114, 115) are only significantly stimulated by cadmium and copper. In the case of copper resistance, the resistance of the biomembrane of copper tolerant plants is more efficient than the small amount of copper bound to phytochelatin (115). It seems that the increase of phytochelatin at whatever metal supply, will not be related to real metal tolerance and may be a primary aspecific metabolic reaction to increased metal supply, comparable to the increase of proline as a first reaction to water stress (29).

Table 4. Glucosinolate content ( $\mu\text{mol g}^{-1}$  fresh wt.) in leaves of metal-resistant and metal-sensitive plant species. Data from (71) and (92).

Plant species	Metal	Glucosinolate content	Reference
<i>Thlaspi alpestre</i> <i>ssp. calaminare</i>	zinc-resistant (Si)	46.3 $\pm$ 10.0	(71)
	zinc-resistant (Ce)	27.2 $\pm$ 5.6	(71)
<i>Thlaspi alpestre</i>	zinc-sensitive (Ho)	18.4 $\pm$ 15.3	(71)
<i>Alyssum bertolonii</i>	nickel-resistant		
	at 0.0 mM Ni	97.1 $\pm$ 10.1	(92)
	0.1 mM Ni.	77.1 $\pm$ 7.2	(92)
<i>Alyssum argenteum</i>	nickel-sensitive		
	at 0.0 mM Ni	71.6 $\pm$ 12.2	(92)
	0.1 mM Ni	54.4 $\pm$ 15.5	(92)

## Conclusion

At the moment, there are a many gaps in knowledge which hamper a real judgement on the ecological role of sulfur in ecosystems. With regard to sulfur uptake from the hydrosphere and pedosphere, the question to be answered is whether the efficiency of radial oxygen loss by aerenchyma is too small so that sulfide uptake preferred to sulfate in anoxic environments, or if *Spartina* species are an exception to the rule. If plants emit various sulfur compounds into the atmosphere, the question remains whether foliar uptake is restricted to sulfur dioxide and hydrogen sulfide, or may be broadened to dimethylsulfide and the various sulfoxides. Can volatile sulfur compounds explain the existence of near-monocultures of *Allium ursinum* and other *Allium* species in forested ecosystems in the Northern hemisphere? After satisfying the sulfur requirement of normal cell metabolism, is accumulation of sulfate and flavonoid sulfates in the vacuoles only an alternative regulation of excessive sulfur instead of H<sub>2</sub>S and DMS emission, or does sulfate play a similar role in the regulation of the hydration of the plants as does sodium chloride? Are sulfur compound-based defense systems completely compensated by increased fitness, thus explaining the success of Brassicaceae in the colonisation of open sites? How strong is the genetic background of all postulated sulfur resistance mechanisms, or are all these suggestions only a one-sided interpretation of wishful thinking?

## Acknowledgement

I thank Dr. J.J.W. Lismann, Library Service of the Free University, for help in updating the bibliography, one of two anonymous referees and Dr. T.A. Dueck, Institute for Plant Protection, Wageningen, for help in the English text, and Miss D. Hoonhout for typing the manuscript.

## Literature cited

1. Ackerman, R.G., Tocher, C.S. and McLachlan, J. 1966. Occurrence of dimethyl- $\beta$ -propiothetin in marine plankton. J. Fish. Res. Board Can. 23: 357-364.

2. Armstrong, W. 1967. The oxidation activity of roots in waterlogged soils. *Physiol. Plant.* 20: 920-926.
3. Baumeister, W. and Ernst, W. 1978. Mineralstoffe und Pflanzenwachstum. Stuttgart. G. Fischer Verlag. 416 pp.
4. Beeftink, W.G. and Rozema, J. 1987. The nature and functioning of salt marshes. In: *Pollution of the North Sea: an assessment*, Salomon, W., Bayne, B.L., Duursma, E.K. and Förstner, U. eds. pp. 59-87, Berlin: Springer Verlag.
5. Bell, J.N.B. 1985. Air pollution problems in Western Europe. In: *Gaseous air pollutants and plant metabolism*, Koziol, M.J. and Whatley, F.R. eds. pp. 3-24, London: Butterworth.
6. Berry, W.L. 1970. Characteristics of salts secreted by *Tamarix aphylla*. *Am. J. Bot.* 57: 1226-1230.
7. Boukhris, M. and Lossaint, P. 1970. Sur la teneur en soufre de quelques plantes gypsophiles de Tunisie. *Oecol. Plant.* 5: 345-354.
8. Boukhris, M. and Lossaint, P. 1972. Spécificité biogéochimique des plantes gypsophiles de Tunisie. *Oecol. Plant.* 7: 45-68.
9. Boukhris, M. and Lossaint, P. 1975. Aspects écologiques de la nutrition minérale des plantes gypsicoles de Tunisie. *Rev. Écol. Biol. Sol* 12: 329-348.
10. Breckle, S.W. 1975. Ionengehalte halophiler Pflanzen Spaniens. *Decbeniana* 127: 221-228.
11. Cantoni, G.L. and Anderson, D.G. 1956. Enzymatic cleavage of dimethylpropiothetin by *Polysiphonia lanosa*. *J. Biol. Biochem.* 222: 171-177.
12. Carlson, P.R. and Forrest, J. 1982. Uptake of dissolved sulphide by *Spartina alterniflora*: evidence from natural sulphur isotope abundance ratios. *Science* 216: 633-635.
13. Challenger, F. and Simpson, M.K. 1948. Studies on biological methylation. XII. A precursor of dimethyl sulphide evolved by *Polysiphonia fastigiata*. Dimethyl 2-carboxyethylsulphonium hydroxide and its salts. *J. Chem. Soc.* 1948: 1591-1598.
14. Chew, F.S. and Rodman, J.E. 1979. Plant resources for chemical defense. In: *Herbivores. Their interaction with secondary plant metabolism*, Rosenthal, G.A. and Janzen, D.H. eds. pp. 271-308, London: Academic Press. 718 pp.
15. Cooper, P.J.M. 1972. Aryl-sulphate activity in Northern Nigerian soils. *Soil Biol. Biochem.* 4: 333-337.
16. Cooper-Driver, G.C. and Swain, T. 1976. Sulfate esters of caffeyl- and coumaryl glucose in ferns. *Phytochemistry* 14: 2506-2507.
17. Dacey, J.W.H., King, G.M. and Wakeham, S.G. 1987. Factors controlling emission of dimethylsulfide from salt marshes. *Nature* 330: 643-645.
18. De Cormis, L. 1968. Dégagement d'hydrogène par les plantes soumises à une atmosphère contenant de l'anhydride sulfureux. *C.R. Acad. Sci. D* 266: 683-685.
19. Delbaert, C., Bris, B., Nouvelat, A. and Constant, D. 1983. Sulphatides and pollination in *Oenothera missouriensis*. *Phytochemistry* 22: 869-874.
20. Denaeyer-De Smet, S. 1970. Note sur la composition chimique des sels recrétés par diverses espèces gypso-halophytes d'Espagne. *Bull. Soc. r. Bot. Belg.* 103: 273-278.
21. Dickson, D.M.J., Wyn Jones, R.G. and Davenport, J. 1980. Steady state osmotic adaptation in *Ulva lactuca*. *Planta* 150: 158-165.
22. Dijkshoorn, W. and van Wijk, A. 1967. The sulfur requirements of plants as evidenced by the sulfur-nitrogen ratio in the organic matter. A review of published data. *Plant Soil* 26: 129-157.
23. Drobnica, L., Zemanova, M., Nemeč, T., Antos, K., Kristian, P., Stullerove, A., Knoppova, K. and Nemeč, P.Jr. 1967. Antifungal activity of isothiocyanates and their analogues. *Appl. Microbiol.* 15: 701-717.
24. Dueck, T.A., Dil, E.W. and Pasman, F.J.M. 1987. The influence of air pollution on grass populations in the Netherlands. *New Phytol.* 108: 167-174.
25. Duvigneaud, P. and Denaeyer-De Smet, S. 1968. Essai de classification chimique (éléments minéraux) des plantes gypsicoles du Bassin de l'Ébre. *Bull. Soc. r. Bot. Belg.* 101: 279-291.
26. Edwards, D.M., Reed, R.H. and Stewart, W.J.P. 1988. Osmoacclimation in *Enteromorpha intestina-lis*: long-term effects of osmotic stress on organic solute accumulation. *Mar. Biol.* 98: 467-476.
27. Ernst, W. 1974. *Schwermetallvegetation der Erde*. Stuttgart. G. Fischer Verlag. 194 pp.
28. Ernst, W. and Walker, B.H., 1973. Studies on the hydrature of trees in miombo woodland in South Central Africa. *J. Ecol.* 61: 667-673.
29. Ernst, W.H.O. 1985. Some considerations of and perspectives in coastal ecology. *Vegetatio* 62: 533-545.
30. Ernst, W.H.O. 1985. Schwermetallimmissionen - ökophysiologische und populationsgenetische Aspekte. *Düsseldorf. Geobot. Koll.* 2: 43-57.

31. Ernst, W.H.O., Tonneijck, A.E.C. and Pasman, F.J.M. 1985. Ecotypic response of *Silene cucubalus* to air pollutants (SO<sub>2</sub>, O<sub>3</sub>). *J. Plant Physiol.* 118: 439-450.
32. Farwell, S.O., Sherrard, A.E., Pack, M.R. and Adams, D.F. 1979. Sulfur compounds volatilized from soils at different moisture content. *Soil Biol. Biochem.* 11: 411-415.
33. Feeny, P., Paauwe, K. and Demong, J.J. 1970. Flea beetles and mustard oils: host plant specificity of *Phyllotreta cruciferae* and *P. striolata* adults (Coleoptera: Chrysomelidae). *Ann. Entomol. Soc. Am.* 63: 832-840.
34. Filner, P., Rennenberg, H., Sekiya, J., Bressan, R.A., Wilson, L.G., Le Cureux, L. and Shimei, T. 1985. Biosynthesis and emission of hydrogen sulfide by higher plants. See Ref. 5: pp. 291-312.
35. Finch, S. 1978. Volatile plant chemicals and their effect on host plant finding by the cabbage root fly (*Delia brassicae*). *Entomol. Exp. Appl.* 24: 350-359.
36. Fowden, L. 1964. The chemistry and metabolism of recently isolated amino acids. *Annu. Rev. Biochem.* 33: 173-203.
37. Free, J.B. and Williams, I.H. 1978. The response of the pollen beetle, *Megilethes aeneus*, and the seed weevil, *Ceuthorrhynchus assimilis*, to oil-seed rape, *Brassica napus* and other plants. *J. Appl. Ecol.* 15: 761-774.
38. Glendering, T.M. and Poulton, J.E. 1988. Glucosinolate biosynthesis. Sulfation of desulfobenzylglucosinolate by cell-free extracts of cress (*Lepidium sativum* L.) seedlings. *Plant Physiol.* 86: 319-321.
39. Gorham, J., Hughes, L.I. and Wyn Jones, R.G. 1980. Chemical composition of salt-marsh plants from Ynys Môn (Anglesey): the concept of physiotypes. *Plant Cell Environ.* 3: 309-318.
40. Greenhalgh, J.R. and Mitchell, N.D. 1976. The involvement of flavour volatiles in the resistance to downy mildew of wild and cultivated forms of *Brassica oleracea*. *New Phytol.* 77: 391-398.
41. Grill, E., Winnacker, E.G. and Zenk, M.H. 1985. Phytochelatins: The principal heavy metal complexing peptides of higher plants. *Science* 230: 674-676.
42. Grill, E., Winnacker, E.L. and Zenk, M.H. 1988. Occurrence of heavy metal binding phytochelatins in plants growing in a mining refuse area. *Experientia* 44: 539-540.
43. Gupta, P.D. and Thorsteinsson, A.J. 1960. Food plant relationship of the diamond back moth (*Plutella maculipennis* Curt.). II. Sensory regulation of oviposition of the adult female. *Entomol. Exp., Appl.* 3: 305-314.
44. Hällgren, J.E. and Fredriksson, S.A. 1982. Emission of hydrogen sulfide from sulfur-dioxide-fumigated pine trees. *Plant Physiol.* 70: 456-459.
45. Harborne, J.B. 1975. Flavour bisulphates and their co-occurrence with ellagic acid in the Bixaceae, Frankeniaceae and related families. *Phytochemistry* 14: 1331-1337.
46. Harborne, J.B. 1977. Flavonoid sulphates: A new class of natural product of ecological significance in plants. *Progr. Biochem.* 4: 189-208.
47. Harris, J.A. 1934. The physico-chemical properties of plant saps in relation to phytogeography. Minnesota: Univ. Minnesota Press.
48. Hattula, T. and Granroth, B. 1974. Formation of dimethyl sulphide from S-methylmethionine in onion seedlings (*Allium cepa*). *J. Sci. Food Agric.* 25: 1517-1521.
49. Havill, D.C., Ingold, A. and Pearson, J. 1985. Sulphide tolerance in coastal halophytes. *Vegetatio* 62: 279-285.
50. Hutchinson, T.C., Gizyn, W., Havas, M. and Zobens, V. 1978. Effect of long-term lignite burning on arctic ecosystems at the Smoking Hills, N.W.T. In: Trace substances in environmental health, Hemphill, D.D. ed. 12: pp. 317-332, Columbia: Univ. Missouri.
51. Ikeshoji, T. 1984. S-propenylcysteine sulfoxide in exudates of onion roots and its possible decompartmentalization in root cells by bacteria into attractant of the onion maggot *Hylemya antiqua* (Diptera: Anthomyiidae). *App. Entomol. Zool.* 19: 159-169.
52. Imperato, F. 1982. Sulphate esters of hydroxycinnamic acid-sugar derivatives from *Adiantum capillus-veneris*. *Phytochemistry* 40: 130-136.
53. Ingold, A. and Havill, D.C. 1984. The influence of sulphide on the distribution of higher plants in salt marshes. *J. Ecol.* 72: 1043-1054.
54. Iversen, T.H., Myhre, S., Evjen, K. and Baggerud, C. 1983. Morphology and myrosinase activity in root protoplasts of Brassicaceae. *Z. Pflanzenphysiol.* 112: 391-401.
55. Janiesch, P. 1973. Ökophysiologische Untersuchungen an Umbelliferen nitrophiler Säume. *Oecol. Plant.* 8: 335-352.
56. Kakes, P. 1985. Linamarase and other  $\beta$ -glucosidases are present in the cell walls of *Trifolium repens* L. leaves. *Planta* 166: 156-160.

57. Kiene, R.P. and Taylor, B.F. 1988. Demethylation of dimethylsulfoniopropionate and production of thiols in anoxic marine sediments. *App. Environ. Microbiol.* 54: 2208-2212.
58. Kjaer, A. 1958. Secondary organic sulfur-compounds of plants (Thiols, sulfides, sulfonium derivatives, sulfoxides, sulfones and isothiocyanates). In: *The metabolism of sulfur- and phosphorus-containing compounds*, Encyclopedia of Plant Physiology 9, Ruhland, W. ed. pp. 64-88, Berlin: Springer Verlag, 306 pp.
59. Kjaer, A. 1974. The natural distribution of glucosinolates: a uniform group of sulfur-containing glucosides. In: *Chemistry in biological classification*, Benz, G. and Santesson, J. eds. pp. 229-234, Stockholm: Nobel Foundation.
60. Kleinkopf, G.E. and Wallace, A. 1974. Physiological basis for salt tolerance in *Tamarix ramossissima*. *Plant Sci. Lett.* 3: 157-163.
61. Ladenburger, K. 1979. Untersuchungen zum Zusammenhang zwischen Blattalterung und Salzbelastung bei einigen Halophyten. Ph.D. Thesis Univ. Wien.
62. Lancaster, J.E. and Collin, H.A. 1981. Presence of alliinase in isolated vacuoles and of alkyl cysteine sulfoxides in the cytoplasm of bulbs of onion (*Allium cepa*). *Plant Sci. Lett.* 22: 169-176.
63. Lancaster, J.E., McCallien, B.J. and Shaw, M.C. 1986. The dynamics of flavour precursors, the S-alkenyl-L-cysteine sulphoxides, during leaf blade and scale development in the onion (*Allium cepa*). *Physiol. Plant.* 66: 293-297.
64. Larher, F., Hamelin, J. and Stewart, G.P. 1977. L'acide dimethyl sulfonium-3-propanoïque de *Spartina anglica*. *Phytochemistry* 16: 2019.
65. Lolkema, P.C., Donker, M.H., Schouten, A.J. and Ernst, W.H.O. 1984. The possible role of metallothioneins in copper tolerance of *Silene cucubalus*. *Planta* 162: 174-179.
67. Louda, S.M. 1986. Insect herbivory in response to root-cutting and flooding stress on a native crucifer under field conditions. *Oecol. Gen.* 7: 37-53.
68. Louda, S.M. and Rodman, J.E. 1983. Ecological patterns in the glucosinolate content of a native mustard, *Cardamine cordifolia*, in the Rocky Mountains. *J. Chem. Ecol.* 9: 397-422.
69. Louda, S.M. and Rodman, J.E. 1983. Concentration of glucosinolates in relation to habitat and insect herbivory for the native crucifer *Cardamine cordifolia*. *Biochem. Syst. Ecol.* 11: 199-207.
66. Lorenc-Plucinska, G. 1982. Effect of sulphur dioxide on CO<sub>2</sub> exchange in SO<sub>2</sub>-tolerant and SO<sub>2</sub>-susceptible Scotch Pine seedlings. *Photosynthetica* 16: 140-144.
70. MacLeod, A.J. and Rossiter, J.T. 1986. Isolation and examination of thioglucosides from seeds of *Brassica napus*. *Phytochemistry* 25: 1047-1051.
71. Mathys, W. 1977. The role of malate, oxalate, and mustard oil glucosides in the evolution of zinc-resistance in herbage plants. *Physiol. Plant.* 40: 130-136.
72. Maw, G.H. 1981. The biochemistry of the sulfonium salts. In: *The chemistry of the sulfonium group*, Stirling, C.J.M. ed. Vol. 2, pp. 703-770, Chichester: J. Wiley.
73. Maynard, D.G., Stewart, J.W.B. and Bettany, J.R. 1985. The effects of plants on soil sulfur transformation. *Soil Biol. Biochem.* 17: 127-134.
74. McGill, W.B. and Cole, C.V. 1981. Comparative aspects of cycling of organic C, N, S and P through soil organic matter. *Geoderma* 26: 267-286.
75. Mitchell, N.D. 1976. Studies on the population of the wild cabbage, *Brassica oleracea* L. subsp. *oleracea*. Ph.D. Thesis, Univ. Newcastle-upon-Tyne.
76. Mitchell, N.D. 1978. Differential host selection by *Pieris brassicae* (the Large White Butterfly) on *Brassica oleracea* subsp. *oleracea* (the Wild Cabbage) *Entomol. Exp. Appl.* 28: 208-219.
77. Mithen, R.F., Lewis, B.G. and Fenwick, G.R. 1986. *In vitro* activity of glucosinolates and their products against *Leptosphaeria maculans*. *Trans. Br. Mycol. Soc.* 87: 433-440.
78. Mithen, R.F., Lewis, B.G., Heaney, R.K. and Fenwick, R.G. 1987. Resistance of leaves of *Brassica* species to *Leptosphaeria maculans*. *Trans. Br. mycol. Soc.* 88: 525-531.
79. Mithen, R.F., Lewis, B.G., Heaney, R.K. and Fenwick, G.R. 1987. Glucosinolates of wild and cultivated *Brassica* species. *Phytochemistry* 26: 1969-1973.
80. Nevell, W. and Wainwright, M. 1987. Seasonal changes in the sulfate content of deciduous woodland soils exposed to atmosphere pollution. *Environ. Pollut.* 47: 195-204.
81. Nriagu, J.O., Holdway, D.A. and Coker, K.D. 1987. Biogenic sulfur and the acidity of rainfall in remote areas of Canada. *Science* 237: 1189-1192.
82. Odum, W.E. 1988. Comparative ecology of tidal freshwater and salt marshes. *Annu. Rev. Ecol. Syst.* 19: 147-176.
83. Phelan, J.R. and Vaughan, J.G. 1980. Myrosinase in *Sinapis alba*. *J. exp. Bot.* 31: 1425-1433.

84. Pladek-Stille, J. 1974. Mineralstoff- und Wasserhaushalt artenreicher Buchenwälder unter Berücksichtigung der Zellsäfte. MSc Thesis Univ. Münster.
85. Reed, R.H. 1983. Measurement and osmotic significance of dimethyl sulphonium-propionate in marine macro-algae. *Mar. Biol. Lett.* 4: 173-181.
86. Rennenberg, H. 1983. The role of acetylserine in hydrogen sulfide emission from pumpkin leaves in response to sulfate. *Plant Physiol.* 73: 560-565.
87. Rennenberg, H. 1984. The fate of excess sulfur in higher plants. *Annu. Rev. Plant Physiol.* 35: 121-153.
88. Rennenberg, H. and Filner, P. 1983. Developmental changes in the potential for H<sub>2</sub>S emission in curcubit plants. *Plant Physiol.* 71: 269-275.
89. Rhoades, D.F. and Cates, R.G. 1976. Toward a general theory of plant antiherbivore chemistry. *Rec. Adv. Phytochem.* 10: 168-213.
90. Rodman, J.E. 1980. Population variation and hybridization in sea-rocket (*Cakile*, Cruciferae): seed glucosinolate characters. *Am. J. Bot.* 67: 1145-1159.
91. Rozema, J., Gude, H. and Pollak, G. 1981. An ecophysiological study of the salt secretion of four halophytes. *New Phytol.* 89: 201-217.
92. Sasse, F. 1976. Ökologische Untersuchungen der Serpentinvegetation in Frankreich, Italien, Österreich und Deutschland. Ph.D. Thesis, Univ. Münster.
93. Seil, H. 1968. Der Einfluss der Chlorid- und Sulfatnahrung auf die osmotischen Werte bei Glykophyten. MSc Thesis, Univ. Münster.
94. Sekiya, J., Wilson, L.G. and Filner, P. 1982. Resistance to injury by sulfur dioxide. Correlation with its reduction to, and emission of, hydrogen sulfide in Cucurbitaceae. *Plant Physiol.* 70: 437-441.
95. Silvius, J.E., Baer, C.H., Dodrill, S. and Patrick, H. 1976. Photoreduction of sulfur dioxide by spinach leaves and isolated chloroplasts. *Plant Physiol.* 57: 799-801.
96. Singer, C.E. and Havill, D.C. 1985. Manganese as an ecological factor in salt marshes. *Vegetatio* 62: 287-292.
97. Spáleny, J. 1977. Sulphate transformation to hydrogen sulphide in spruce seedlings. *Plant Soil* 48: 557-563.
98. Steudler, P.A. and Peterson, B.J. 1984. Contribution of gaseous sulfur from salt marshes to the global sulphur cycle. *Nature* 311: 455-457.
99. Strickland, T.C. and Fitzgerald, J.W. 1985. Incorporation of sulphate-sulphur into organic matter extracts of litter and soil: Involvement of ATP sulphurylase. *Soil Biol. Biochem.* 17: 779-784.
100. Takemoto, B.K., Noble, R.D. and Harrington, H.M. 1986. Differential sensitivity of duckweeds (*Lemnaceae*) to sulphite. II. Thiol production and hydrogen sulphide emission as factors influencing sulphite phytotoxicity under low and high irradiance. *New Phytol.* 103: 541-548.
101. Taylor, G.E. Jr. and Murdy, W.H. 1975. Population differentiation of annual plant species, *Geranium carolinianum* L., in response to sulfur dioxide. *Bot. Gaz.* 136: 212-215.
102. Taylor, G.E. Jr. and Tingey, D.T. 1981. Physiology of ecotypic plant response to sulfur dioxide in *Geranium carolinianum* L. *Oecologia* 49: 76-82.
103. Taylor, G.E. Jr., Tingey, D.T. and Gunderson, C.A. 1986. Photosynthesis, carbon allocation, and growth of sulfur dioxide ecotypes of *Geranium carolinianum* L. *Oecologia* 68: 350-357.
104. Thurman, D.A., Salt, D.E. and Tomsett, A.B. 1989. Copper phytochelatin of *Mimulus guttatus*. In: Metal ion homeostasis: molecular biology and chemistry, Winge, D. and Hamer, D. eds. pp. 367-374, New York: Alan R. Liss Inc.
105. Tomás-Barberán, F.A., Harborne, J.B. and Self, R. 1987. Twelve 6-oxygenated flavone sulphates from *Lippia nodiflora* and *L. canescens*. *Phytochemistry* 26: 2281-2284.
106. Tsujimura, A. 1979. The arrangement of the vegetation of solfataras according to pH (hydrogen ion concentration) value of soils (Japan). *Ecol. Rev. Jap.* 19: 59-65.
107. Turner, M.S., Malin, G., Liss, P.S., Harbour, D.S. and Holligan, P.M. 1988. The seasonal variation of dimethylsulfide and dimethylsulfoniopropionate concentration in nearshore waters. *Limnol. Oceanogr.* 33: 364-375.
108. Van Diggelen, J., Rozema, J., Dickson, D.M.J. and Broekman, R. 1986.  $\beta$ -3-dimethylsulphoniopropionate, proline and quaternary ammonium compounds in *Spartina anglica* in relation to sodium chloride, nitrogen and sulphur. *New Phytol.* 103: 573-586.
109. Van Diggelen, J., Rozema, J. and Broekman, R. 1987. Mineral composition of and proline accumulation by *Zostera marina* L. in response to environmental salinity. *Aquat. Bot.* 27: 169-176.
110. Van Diggelen, J., Rozema, J. and Broekman, R. 1987. Growth and mineral relations of salt marsh

- species on nutrient solutions containing various sodium sulphide concentrations. In: Vegetation between land and sea, Huiskes, A.H.L., Blom, C.W.P.M. and Rozema, J. eds. pp. 260-268, Dordrecht: W. Junk Publ.
111. Van Diggelen, J. 1988. A comparative study on the ecophysiology of salt marsh halophytes. Ph.D. Thesis. Free Univ. Amsterdam.
  112. Van Etten, C.H. and Tookey, H.L. 1979. Chemistry and biological effects of glucosinolates. In: Herbivores. Their interaction with secondary plant metabolites, Rosenthal, G.A. and Janzen, D.H. eds. pp. 471-500, New York: Academic Press, 718 pp.
  113. Varin, L., Barron, D. and Ibrahim, R.K. 1987. Enzymatic assay for flavonoid sulfotransferase. *Anal. Biochem.* 161: 176-180.
  114. Verkleij, J.A.C., Koevoets, P., Van 't Riet, J., Van Rossenberg, M.C., Bank, R. and Ernst, W.H.O. 1989. The role of metal-binding compounds in the copper tolerance mechanism of *Silene cucubalus*. See Ref. 104, pp. 347-357.
  115. Verkleij, J.A.C. and Schat, H. 1989. Mechanisms of metal tolerance in plants. In: Heavy metal tolerance in plants: evolutionary aspects, Shaw, J. ed. (in press). Boca Raton: CRC Press.
  116. Visser, J.H. 1986. Host odor perception in phytophagous insects. *Annu. Rev. Entomol.* 31: 121-144.
  117. Waisel, Y. 1961. Ecological studies on *Tamarix aphylla* (L.) Karst. III. The salt economy. *Plant Soil* 13: 356-364.
  118. White, R.H. 1982. Analysis of dimethyl sulfonium compounds in marine algae. *J. Mar. Res.* 40: 529-536.
  119. Wilson, L.G., Bressan, R.H. and Filner, P. 1978. Light-dependent emission of hydrogen sulfide from plants. *Plant Physiol.* 61: 184-189.
  120. Winner, W.E., Smith, C.L., Koch, G.W., Mooney, H.A., Bewley, J.D. and Krouse, H. R. 1981. Rates of emission of H<sub>2</sub>S from plants and patterns of stable sulphur isotope fractionation. *Nature* 289: 672-673.
  121. Wyn Jones, R.G. and Gorham, J. 1983. Osmoregulation. In: Physiological plant ecology III. Encyclopedia of plant physiology, New series 12C, Lange, O.L., Nobel, P.S., Osmond, C.B. and Ziegler, H. eds. pp. 35-58, Berlin: Springer Verlag.
  122. Yerly, M. 1970. Ecologie comparée des prairies marécageuses dans les Préalpes de la Suisse occidentale. *Veröff. Geobot. Inst. Stiftung Rübel Zürich* 44: 1-119.

# THE EFFECT OF SULFATE AND METHIONINE ON LEGUME PROTEINS

John F. Thompson and James T. Madison

*U.S. Plant, Soil and Nutrition Laboratory, Agricultural Research Service, U.S. Department of Agriculture, Tower Road, Ithaca, N.Y. 14853 U.S.A.*

## Contents

Introduction	145
Effect of sulfur deficiency on legume seed storage proteins	146
Effect of methionine on legume seed proteins and expression of their genes	149
Increasing protein methionine by modification of existing storage protein genes or incorporation of high methionine protein genes	154
Literature cited	155

## Introduction

Over the years, there has been a great deal of interest in the nutritional quality of legume seed proteins because legume seeds are a major source of essential amino acids in the diets of humans and monogastric animals (61). The need for better plant proteins will grow as the population increases and the amount of arable land declines. Unfortunately, the essential amino acid balance of legume seed proteins is not appropriate for the optimum utilization of these proteins by monogastric animals (30, 33, 61). Hence, there has been substantial interest in improving the nutritional quality of legume proteins by raising the level of the sulfur amino acids (45), the first limiting amino acids (30, 33).

There are several potential ways to increase the sulfur amino acid content of legume seed proteins. First, select cultivars with higher methionine and cyst(e)ine levels. Second, change the relative amount of storage proteins. Third, introduce a foreign gene coding for more methionine and cyst(e)ine into the genome. Fourth, modify the soybean storage protein genes to code for more methionine and cyst(e)ine. Because of the desire to increase sulfur amino acids and because, after nitrogen, sulfur is the most important protein element supplied from the soil, the effect of sulfur supply on legume proteins has been extensively investigated (65).

The majority of the legume storage proteins are globulins commonly of two classes. Both classes are comprised of unusually large proteins having a number of subunits. The smaller of the two classes has a molecular weight of 150-200 kDa and is often termed a 7S protein. This protein is given different names depending on the plant [*e.g.*, vicilin in peas (*Pisum sativum*); conglycinin in soybeans (*Glycine max*);



phaseolin in the common bean (*Phaseolus vulgaris*); conglutin in European blue lupine (*Lupinus angustifolius*) and is commonly glycosylated. The larger storage protein has a molecular weight of 300-400 kDa and, because it has a sedimentation coefficient of 11-13S (27), it is commonly referred to as the 11S protein. Examples of the 11S protein are legumin in pea, glycinin in soybean and glutinin in lupine.

### Effect of sulfur deficiency on legume seed storage proteins

The earliest investigators determined the effects of sulfur level supplied on the growth of legumes and their yield of seed (65). Then investigators became more concerned with the nutritional quality of vegetative parts and the seeds (*e.g.*, 31). The next phase of work measured the levels of methionine and cyst(e)ine in seeds (5, 70).

In more recent times, investigators looked at the individual proteins and subunits and the mechanisms by which sulfur levels can cause changes. Most of the work has been with the storage proteins because they make up the majority of the protein in the seed and because the other proteins are essential for normal functioning of the seed and are therefore more likely to be 'protected' from fluctuations in the sulfur supply.

In one of the first studies that included legume storage proteins and their subunits, Blagrove *et al.* (11) found that sulfur deficient European blue lupine seed had a nitrogen to sulfur ratio of 80 whereas in normal plants this ratio was only 18 to 22. In seeds supplied with an abnormally high supply of sulfur, the ratio was reduced even further to 13 to 16. This latter finding is typical of other work where the difference between normal and supranormal sulfur supply has minor effects on proteins (64). Blagrove *et al.* (11) also found that the total cyst(e)ine level in the seed of sulfur deficient lupine was about 25% of that of normal plants but the methionine level was not affected as much. Some of this difference in cyst(e)ine and methionine content could have been in the non-protein fraction, since Macnicol (52) observed that the uncombined methionine level is more constant than the cyst(e)ine level in peas at different sulfur nutrition levels. In the lupine, there was also a marked change in the subunit composition of the storage proteins. The conglutin  $\beta$ -subunit, with a lower level of sulfur amino acids, was increased while the  $\alpha$ - and  $\gamma$ -subunits of conglutins were decreased in sulfur deficient plants (the electrophoretograms indicated at least a ten fold decrease in  $\alpha$  and  $\gamma$ ).

In soybeans, Gayler and Sykes (38) observed a similar response. Sulfur sufficient seed contained 18.3 mg glycinin/g defatted meal and 13.3 mg conglycinin/g. Under sulfur deficiency, the glycinin level was lowered to 10.3 mg/g while conglycinin increased to 23.3 mg/g. Since glycinin contains a higher level of sulfur than conglycinin, these results indicate that, in the absence of a sufficient amount of sulfur, proteins with a lower sulfur content are preferentially synthesized. At the same time the total amount of storage protein was maintained at about the same level.

The work with lupine (11) has been repeated and extended in studies on the effect of sulfur deficiency on the storage proteins of pea seeds. Sulfur deficient plants yielded seeds with a decreased level of legumin (10% of normal) and of one vicilin subunit that was accompanied by an increase in a major vicilin subunit (64). As with the soybean, the 11S protein of peas (legumin) contains more sulfur than the 7S protein (vici-

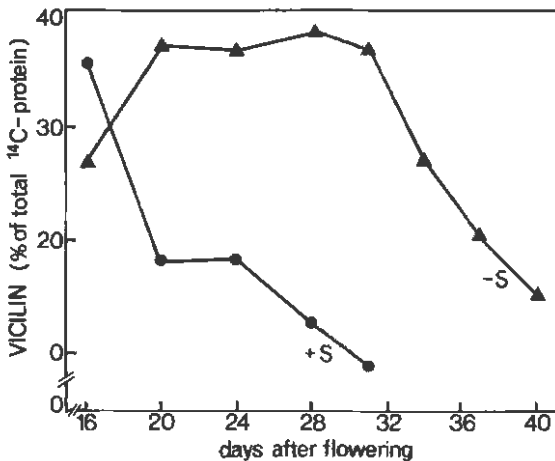

Fig. 1. Vicilin synthesis during development of sulfur deficient (-S) and normal pea plants (+). Seeds were removed from plants at various intervals and then pulse labeled with a mixture of fourteen radioactive amino acids. From Chandler *et al.*, (16) with permission of authors and publisher.

lin)(27). The more drastic decrease in the 11S protein of peas as compared to soybeans (38) could have been due to a difference in the severity of the sulfur deficiency and/or the species. Then it was found that the vicilin polypeptide chain which decreased, contained more sulfur than the major vicilin subunit that increased (55). Legumin and vicilin are salt-soluble globulins. Among the water-soluble albumins, the sulfur-rich ones were more depressed than other albumins in sulfur deficient plants, but the total albumin fraction, which is relatively sulfur-rich, was 30% less in sulfur deficient seeds (66). Interestingly, among a wide range of pea lines, the legumin fraction varied inversely with the albumin fraction. If the latter finding extends to other situations, the ability to raise pea seed sulfur amino acid content by increasing sulfur-rich albumins (42, 46) may be difficult.

In an effort to establish the mechanism for the effect of sulfur nutrition on the storage protein profile, Macnicol (52) determined the level of free cyst(e)ine and methionine as well as the aminoacyl-tRNA pool in seeds at an active stage of vicilin and legumin synthesis. Free cyst(e)ine was severely depressed by sulfur deficiency (17% of normal) but free methionine was unaffected. Although the total aminoacyl-tRNA pool in sulfur-deficient plants was only one third that of normal plants (2.1 vs 6.4 nmole/cotyledon), the relative levels of cyst(e)ine and methionine aminoacyl-tRNAs were unchanged, indicating that legumin synthesis was not limited by availability of the sulfur amino acids.

It is possible that the effect of sulfur deficiency on the legumin level is due to either a reduction in transcription of the legumin gene or an accelerated degradation of legumin. Pulse-chase experiments (15) revealed that there is no accelerated degradation of legumin in sulfur deficient plants as shown by the fact that the labeling of legumin by radioactive amino acids is the same percent of the total protein labeled at 20 hrs (1.6%) after the pulse as after 10 min. (1.0%). The corresponding values for sulfur-sufficient plants are 10.5 % and 8.3%, respectively. Sulfur deficiency apparently acts by decreasing the transcription of the legumin gene since legumin

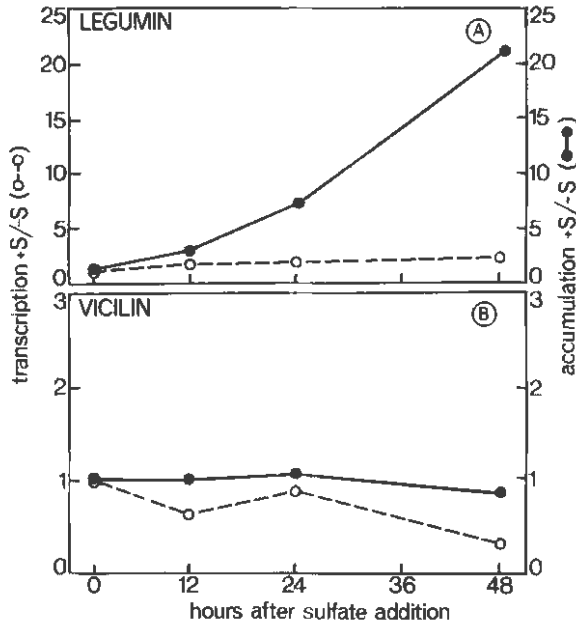

Fig. 2. A comparison of the transcription rate and mRNA accumulation for legumin and vicilin during recovery from sulfur deficiency with the initial values (+S/-S). Transcription was measured by hybridization of total transcripts from nuclei to specific cDNA clones. From Beach *et al.*, (8) with permission of authors and publisher.

mRNA was reduced by 60-70% in sulfur-deficient pea plants (15, 16). The increased level of vicilin in sulfur deficient plants was engendered by prolonged synthesis related to a continued high mRNA level as compared to normal plants (Fig. 1) since vicilin normally appears before legumin and ceases accumulating sooner (34, 35). The decline in vicilin may be due to specific proteolysis (36). This effect could be related to the effect of hormones since abscisic acid increases the rate of storage protein accumulation in the common bean (73) where a vicilin-like protein is predominant (25). A similar effect of sulfur deficiency on the formation of conglycinin and its  $\beta$ -subunit, and glycinin was observed in soybeans (38, 44).

A rapid change in legumin and vicilin levels on the addition of sulfur to deficient plants, indicates that the effects are readily reversible (15). In soybeans, the effect of methionine on the  $\beta$ -subunit is also readily reversed (43). These results could mean that sulfur deficiency has a pronounced effect on transcription of storage protein genes that is mediated by transcription factors. Consistent with this idea are the findings of Beach *et al.* (8) and of Higgins *et al.* (42) who concluded that the effect of sulfur deficiency on both storage globulins and albumins was due to both transcriptional and post-transcriptional processes even though normal developmental control of these proteins was thought to be only transcriptional. This conclusion was reached when they observed that, in recovery from a sulfur deficient condition, legumin mRNA increased more rapidly than the rate of transcription while vicilin mRNA was unchanged (Fig 2)(8). A similar behavior was manifest with the pea seed albumins

(42). Thus, sulfur deficiency could conceivably accelerate the degradation of legumin mRNA.

Since vicilin subunits are glycosylated, it is possible that sulfur deficiency affects glycosylation. However, there is no evidence that sulfur deficiency has any effect on glycosylation of the vicilin polypeptides since inhibition of glycosylation by tunicamycin appears to have little, if any, effect on the synthesis and maturation of vicilin polypeptides (6).

Further investigation into the mechanisms involved in experiments with sulfur deficient legumes may make it possible to increase the sulfur amino acid content of legume seeds.

### Effect of methionine on legume seed proteins and expression of their genes

The above studies demonstrate that sulfur deficiency markedly affects the storage proteins of legume seeds, but that a supraoptimal supply of sulfate has a negligible effect on the storage proteins. In our research, we have found that exogenous methionine can have a specific effect on the expression of storage protein genes and on the sulfur amino acid content of soybean seeds. Protein methionine has been emphasized, since the majority of methionine (and cyst(e)ine) in legume seeds occurs in proteins. Soybean seeds were selected for study because they have such a high level of protein and because they are such an important source of protein for both humans and animals (82). We have focused on increasing methionine rather than cyst(e)ine because altering cyst(e)ine might have a more adverse effect on protein structure and hence on the seed. Emphasis was placed on the seed storage proteins because changes in the structure of storage proteins should not have the adverse effect on the plant that a structural change in enzymes or membrane proteins would have and because they constitute a majority of the seed proteins. In order to study the development of storage proteins under controlled conditions, a technique for growing immature soybean seeds in culture was developed (78). With this culture system, the seeds grow faster than on the plant (1, 78), but the storage proteins develop as they do on an intact plant (44). When seeds were cultured on a medium supplemented with methionine, the growth as measured by dry weight of the seeds was increased by 23.6% and the methionine content of the protein was increased by 21.9% (79). The *in vitro* effect on protein methionine has been confirmed by stem infusion of methionine into whole plants (39). No other protein amino acid gave the same growth effect (79). The growth effect due to methionine apparently was due to the fact that the cultured seed could not synthesize methionine rapidly enough since seeds cultured with methionine had about 20% more methionine attached to methionyl-tRNA than seeds cultured on basal medium (79). Furthermore, several non-protein amino acid precursors of methionine did not give the same growth effect as methionine indicating that the regulation of methionine biosynthesis might be at the step of homocysteine methylation.

Examination of the storage protein of seeds cultured without and with methionine revealed that methionine-supplemented seeds contained about 50% more glycinin than unsupplemented seeds (32 vs 21 mg/g). This effect of methionine was unique since no other protein amino acid manifested it (43). Concomitant with this increase

Table 1. Storage protein content of soybean cotyledons cultured with and without added methionine.

Protein fraction	Methionine	
	Minus	Plus
	mg/g wet weight	
7S	26	18
$\alpha'$ -subunit	5.8	6.6
$\alpha$ -subunit	10.3	11.4
$\beta$ -subunit	10.2	0
11S	21	32
11S + 7S	47	50
11S/7S	0.8	1.8

in glycinin was a corresponding decrease in conglycinin (18 vs 26 mg/g). Thus the total level of the two principal storage proteins was nearly the same, indicating that there is some mechanism for maintaining a more or less constant level of storage protein as with lupine (11). Further evidence for this regulation derives from the work with peas where vicilin synthesis was prolonged when legumin synthesis was limited by a sulfur deficiency, as noted above (Fig. 1)(16). Since both of these storage proteins occur in protein bodies (22), there may be some control on the total level of protein in a protein body or on the transport to the protein body (20). In any event, the increased methionine in the protein from seeds cultured with supplemental methionine can be mostly explained by the shift from conglycinin to glycinin since glycinin contains more methionine (27). However, this simple explanation does not deal with a possible mechanism.

Further investigation showed that the supplemental methionine changed the relative amount of subunits in conglycinin (44). Specifically, the  $\beta$ -subunit of conglycinin, which contains no methionine (44, 76), was markedly decreased while the  $\alpha$ - and  $\alpha'$ -subunits were about the same (Table 1)(44). This finding could be explained in the following way. The current model for conglycinin is that it is made up primarily of three different subunits,  $\alpha$ ,  $\alpha'$  and  $\beta$ , aggregated in trimers with diverse combinations of the three different subunits (e.g.,  $\alpha_2\alpha'$ ,  $\alpha_3$ ,  $\alpha\beta_2$ , etc.)(77). When the  $\beta$ -subunit is missing, the conglycinin trimers are made up of the other subunits,  $\alpha$  and  $\alpha'$ , and the  $\alpha$ - and  $\alpha'$ -subunits do not make up as much 7S protein. The seed is apparently programmed to make a set amount of the  $\alpha$ - and  $\alpha'$ -subunits and, when the  $\beta$ -subunit is lacking, the  $\alpha$ - and  $\alpha'$ -subunits assemble into trimers in the same proportion and amount as when the  $\beta$ -subunit is present.

One possible explanation for the absence of the  $\beta$ -subunit is that exogenous methionine accelerated the degradation of the  $\beta$ -subunit, but this is not the case (43) (Fig. 3). When seeds are grown on basal medium to allow an accumulation of the  $\beta$ -subunit prior to the addition of methionine to the medium, the  $\beta$ -subunit increases until the added methionine had penetrated into the seed. After that, the amount of  $\beta$ -subunit remains level with no sign of degradation. Since the  $\beta$ -subunit contains no methionine (44, 76), another possible explanation for these results is that, in the basal medium, the seed cannot make methionine fast enough and that, in the absence of adequate methionine, the synthesis of the  $\beta$ -subunit continues unabated while synthesis of the  $\alpha$ - and  $\alpha'$ -subunits is restricted. Then, when there is adequate methionine,

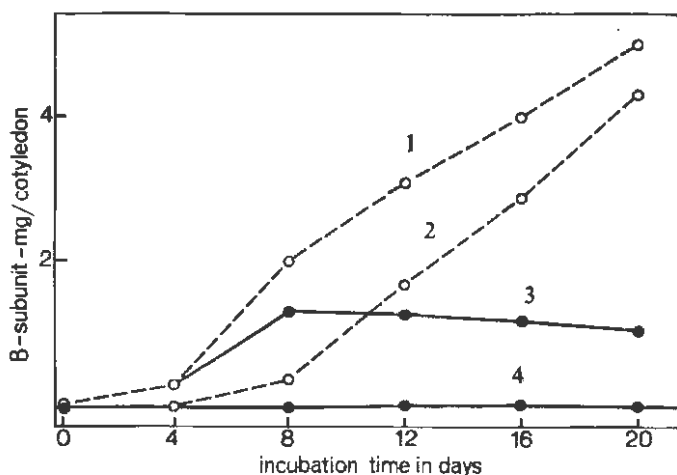

Fig. 3.  $\beta$ -Subunit levels in cultured soybean seeds grown for 16 days with or without supplemental methionine (8 mM). Seeds were cultured for four days without (open circles) or with added methionine (closed circles). After four days, the medium was replaced with fresh medium without or with methionine. Curve 1 presents the  $\beta$ -subunit content of seeds grown 4 days without methionine and then transferred to medium without methionine. Curve 2 presents the  $\beta$ -subunit content of seeds grown 4 days with methionine and then transferred to medium without methionine. Curve 3 presents the  $\beta$ -subunit content of seeds cultured 4 days without methionine and then transferred to medium with methionine. Curve 4 presents the  $\beta$ -subunit content of seeds cultured 4 days in medium containing methionine and transferred to medium containing methionine. From Holowach *et al.* (43) with permission of authors and publisher.

the  $\alpha$ - and  $\alpha'$ -subunits are made in preference to the  $\beta$ -subunit. One difficulty with this explanation is that it assumes that the plant is normally methionine deficient, since seeds formed *in vivo* contain the  $\beta$ -subunit. A second difficulty with this explanation is that there is no translatable  $\beta$ -subunit messenger RNA in seeds cultured with methionine (23) nor is there evidence for untranslatable  $\beta$ -mRNA from a first transcript (43). However, it is possible that the methionine is hastening the degradation of  $\beta$ -mRNA or a precursor, but we lack good evidence on this possibility. We have evidence that methionine has less of an adverse effect on the transcription of the  $\beta$ -gene than on the post transcriptional formation of the  $\beta$ -mRNA (Singer-unpublished data) and this evidence is consistent with other work (32, 81), where it was concluded that post transcriptional processing is a significant factor in controlling storage proteins mRNA levels in seeds.

The possibility that exogenous methionine is acting by methylating the  $\beta$ -gene was considered because methylation of genes can regulate gene expression (14). Methylation of plastid genes is inversely correlated with gene expression (57). However, the evidence in relation to storage protein genes is mixed. In developing soybeans, it was concluded that DNA methylation was not involved in storage protein gene expression (81) whereas in maize, DNA methylation appeared to be related to, if not responsible for, the absence of transcription of these genes in vegetative tissues (10). By the use of methionine analogs, it was found that the  $\beta$ -subunit could be completely suppressed without any increase in S-adenosylmethionine (24) indicating that, if there is any methylation of the  $\beta$ -gene, it is not a result of an increase in S-adenosyl-

methionine, the normal methyl donor. Furthermore, S-ethylcysteine, an analog of methionine, suppresses the expression of the  $\beta$ -gene, as does methionine (24). S-ethylcysteine could not act by methylation of the  $\beta$ -subunit gene, although it could theoretically 'ethylate' the  $\beta$ -gene. However, ethylation of a gene seems unlikely. Another point that should be made is that methylation of the  $\beta$ -gene should hamper transcription more than post-transcriptional processes but methionine has less effect on transcription than on post-transcriptional processes, as mentioned above (Singer-unpublished data).

The  $\beta$ -subunit not only reacts differently to the presence of methionine but also behaves differently during development on the plant. Gayler and Sykes (37) observed that the  $\beta$ -subunit appears later in development in the soybean seed than the  $\alpha$ - and  $\alpha'$ -subunits. In general, the appearance of the subunits during development parallels the level of the corresponding mRNAs, indicating that the developmental regulation depends on pre-translational processes (50, 54). However, the appearance of conglycinin mRNAs does not coincide with appearance of the subunits and this lack of coincidence was found to be due to protein turnover, particularly during the early phase of soybean maturation (71). Although this finding disagrees with those of Madison *et al.* (53), who observed little protein turnover during culture of immature soybean seeds, this disagreement was thought to be related to turnover of the  $\beta$ -subunit during the early phases but not during the late phases of seed maturation (71). Regulation of the appearance of the  $\beta$ -subunit after the  $\alpha$ - and  $\alpha'$ -subunits during soybean seed ontogeny depends on the DNA sequence 200-300 nucleotides upstream of the transcriptional start site (18). When the genomic clones of  $\alpha'$ - and  $\beta$ -subunits are introduced into petunia (*Petunia hybrida*) in either parallel or opposite orientation, the temporal appearance of the  $\alpha'$ - and  $\beta$ -subunits in the petunia seed is similar to that *in vivo* indicating that the inserted genes included the required regulatory regions (60).

As part of the work with methionine analogs, the effect of methionine concentrations on the amount of  $\beta$ -subunit in cultured seeds (24) and the level of free methionine in developing seeds on the plant was determined. When the concentration of methionine added to the culture medium is below about 0.1 mM, the  $\beta$ -subunit is formed whereas when the methionine concentration is above about 0.2 mM, no  $\beta$ -subunit is present. The free methionine concentration in the developing seed on the plant declines from about 0.3 mM to less than 0.05 mM (assuming the fresh tissue is all water). The  $\beta$ -subunit appears during development at the time when the free methionine concentration falls below the threshold level for the appearance of the  $\beta$ -subunit in cultured seeds. This result suggests the possibility that free methionine may be involved in regulating the normal developmental processes in the soybean.

Another consideration is that abscisic acid enhances growth and protein accumulation of cultured soybean embryos during the early stages of development (1), a period when soybeans accumulate abscisic acid (62). Unfortunately, Ackerson (1) did not measure either the storage proteins or their subunits. Subsequent work (12) showed that abscisic acid increases the level of the  $\beta$ -subunit, but not  $\alpha$ - and  $\alpha'$ -subunits, in cultured seeds under special conditions. In addition, when abscisic acid level is lowered by inhibition of its synthesis (by fluoridone), the  $\beta$ -subunit is decreased. These changes in the amounts of the conglycinin subunits are also reflected in the level of their mRNAs (12). Since methionine is not known to have any effect on abscisic acid

levels, the effect of methionine and abscisic acid are presumably completely independent phenomena. The abscisic acid effect further emphasizes the behavioral difference between the  $\beta$ -subunit and the  $\alpha$ - and  $\alpha'$ -subunits.

The  $\beta$ -subunit gene shares considerable homology with those for the  $\alpha$ - and  $\alpha'$ -subunits (67, 80). The major difference is that the  $\alpha$ - and  $\alpha'$ -subunits have an insert in the first exon (29, 67, 68). However, there is considerable difference in the nucleotide sequence of the introns (29). There is no reason to believe that the difference in expression between the  $\alpha$ - and  $\alpha'$ -subunit genes as compared to the  $\beta$ -subunit genes is due to intron variation. To date, control of gene expression has not been shown to reside in the introns, but in the 5'-untranslated regions (49). There is good evidence that regulation of the tissue specific expression of the  $\alpha$ - and  $\alpha'$ -genes resides between 159 and 257 base pairs upstream of the transcription of the start site (18). Unfortunately, no comparison of this region of the  $\beta$ -subunit gene is available so that at this time it remains to be seen whether this region is also involved in the differential regulation of the  $\beta$ -gene as compared to the  $\alpha$ - and  $\alpha'$ -genes.

Another possible regulator of gene expression could be a DNA binding protein (49). There is evidence that nuclear proteins bind to upstream region of  $\alpha'$ -gene of soybean 7S protein and regulate formation of the  $\alpha'$ -subunit (2) and that a soybean lectin gene (seed specific) is regulated by a DNA binding protein from the nuclei (47). Perhaps, the methionine effects operate through a binding protein.

In order to isolate the  $\beta$ -subunit gene, we isolated mRNA from seeds cultured without and with added methionine (de Banzie-unpublished data). When those mRNAs were translated *in vitro*, it was found that there were mRNAs present in the seeds grown with methionine which were not present in the seeds cultured without methionine. cDNA was prepared from these mRNAs, cloned and sequenced. Three of four clones isolated were identical except for length and position of the poly(A) region. A comparison of these sequences to the soybean sequences in the NIH GenBank database revealed that the derived amino acid sequence matched that of the Bowman-Birk proteinase inhibitor (59) except for an additional tyrosine residue at the C-terminal end. The nucleotide sequence of the clone contained 122 bases in the amino acid coding region. All but eight of these bases were identical to the published DNA sequence of a Bowman-Birk protease inhibitor (40), but none of the differences had an effect on the amino acid sequence since they were in the 'wobble' position. It is clear that Hammond *et al.* (40) sequenced a cDNA from a different gene and yet they have the same amino acid sequence as our cDNA sequence. Using the cDNA clone, it was found that methionine increased the mRNA for the Bowman-Birk protease inhibitor by more than 10 fold. In addition, methionine supplied to cultured seeds increased the Bowman-Birk protease inhibitor activity, though the presence of some sulfate was necessary for a pronounced effect. These results showed that sulfur compounds had a marked effect on Bowman-Birk protease inhibitor level. This relationship was further examined by growing soybean plants on different sulfate levels. It was found that at higher sulfate supply levels, the inhibitor was higher, but not proportional to the sulfur supplied. Hence it appeared that, above a certain sulfur level, protease inhibitor was not increased further (Biermann *et al.*, unpublished).

These results leave the identity of the effector molecule in doubt. There is no obvious reason why methionine should induce the Bowman-Birk protease inhibitor that contains 20 mole percent cyst(e)ine and one methionine. In an effort to get a clue, ad-



vantage was taken of the fact that Bowman-Birk protease inhibitors increase in the soybean seed during development (75). Soybean seeds of different ages were analyzed for uncombined cyst(e)ine and Bowman-Birk protease inhibitors and a negative correlation was found. This result clearly indicates that cyst(e)ine is not inducing the inhibitors although it could be argued that cyst(e)ine can reduce inhibitor level. More direct evidence against cyst(e)ine acting as an effector was that the cyst(e)ine content of seeds cultured with various levels of sulfate and methionine showed a poor correlation between free cyst(e)ine level and inhibitor content. Adding cyst(e)ine to the culture medium did not answer the question because the cyst(e)ine was not absorbed.

Attempts to implicate glutathione in the induction of inhibitors by either feeding glutathione to or by measuring glutathione in cultured seeds or by adding a glutathione synthesis inhibitor (buthionine sulfoximine) gave no evidence of the involvement of glutathione (unpublished results). It would be highly desirable to understand the underlying mechanism that governs the level of Bowman-Birk protease inhibitors because they contain 20 mol % cysteine and can contribute a substantial percentage of the seed cyst(e)ine. Ability to increase these protease inhibitors in the soybean would increase the sulfur amino acid content. The negative aspect of this possibility is that the trypsin inhibitors in unheated soybeans have undesirable effects on animals (63).

#### **Increasing protein methionine by modification of existing storage protein genes or incorporation of high methionine protein genes**

Another approach to increasing protein methionine is the incorporation of a gene for a methionine-rich protein into the genome. With this in mind, investigators have been searching for such proteins (26, 48, 83). Youle and Huang (83) analyzed a number of seeds and found that the brazil nut has a particularly high protein methionine content. This methionine-rich protein was purified (72), and the gene for this protein was isolated (3). To our knowledge, no one has produced a plant transformed with this gene. However, this approach is feasible since storage proteins have been introduced into petunia (*Petunia hybrida*) (9, 13, 17, 51, 56) and into tobacco (*Nicotiana tabacum*) (7, 60, 69). In all cases, these genes are expressed in a normal fashion developmentally and in a tissue-specific manner.

De Lumen and Kho (26) devised a method for identifying methionine-rich proteins by reacting radioactive iodoacetate with proteins that had been transferred to nitrocellulose after electrophoresis. Since the radioactivity is correlated with the methionine content of the proteins, they were able to identify several methionine-rich proteins in soybeans in this way. It should be possible to obtain plant genes that code for proteins with a high methionine content that are compatible with storage proteins and would be properly inserted into protein bodies. Argos *et al.* (4) compared the amino acid sequences of a number of legume storage proteins and made predictions as to the regions of helicity. In addition, they have suggested regions where alterations could be made or segments inserted for the express purpose of modifying the amino acid composition.

The possibility of modifying the storage protein genes to code for methionine and cyst(e)ine has been considered (3, 21, 58). This approach may not be feasible because

legume storage protein genes are in multigene families (19, 28, 29, 41, 58, 74) and therefore it may be difficult to modify enough genes to make a significant effect on sulfur amino acid content. To our knowledge, no one has successfully utilized this approach.

In conclusion, it appears that there are several options for the modification of legume seed storage proteins in order to improve the nutritional quality. Sulfur-deficient plants contain a lower level of sulfur amino acids than normal plants. When the mechanism for the decreased protein sulfur is established, it may be possible to manipulate genes in such a way that a higher sulfur amino acid content of the seed will be the normal case. In an analogous way, added methionine can increase protein sulfur by decreasing the  $\beta$ -subunit of the 7S protein and thus affecting the relative amount of the two major storage proteins. In this case, it should be possible to accomplish this objective without understanding the mechanism. Specifically, the preparation of a gene to express an antisense RNA and its insertion into the genome, could result in the suppression of the  $\beta$ -subunit and thus increase the ratio of glycinin to conglycinin with a resultant increase in protein sulfur.

It should be possible to insert high methionine protein genes into plants and have them properly expressed in the seed. Storage protein genes have been transferred into non legumes with proper formation of the proteins and expression in the seeds (9, 13, 69). The question is whether non-storage protein genes would function properly in a transgenic plant. In addition, it has been shown that in the common bean, abscisic acid stimulates storage protein synthesis in cultured seed (73) and in soybean abscisic acid stimulates the synthesis of the  $\beta$ -subunit (12). Therefore, it is possible that abscisic acid inhibitors could increase the sulfur content of legume seeds. Furthermore, abscisic acid may be involved in some of the effects of sulfur deficiency or methionine on storage proteins. With several options available, it appears likely that the problem of low sulfur in legume seeds will be solved, but it is not yet clear what technique will prove most successful.

## Literature cited

1. Ackerson, R.C. 1984. Regulation of soybean embryogenesis by abscisic acid. *J. Exp. Bot.* 35: 403-413.
2. Allen, R.D., Bernier, F., Lessard, P.A. and Beachy, R.N. 1989. Nuclear factors interact with a soybean  $\beta$ -conglycinin enhancer. *Plant Cell* 1: 623-631.
3. Altenbach, S.B., Pearson, K.W., Leung, F.W. and Sun, S.S.M. 1987. Cloning and sequence analysis of a cDNA encoding a brazil nut protein exceptionally rich in methionine. *Plant Mol. Biol.* 8: 239-250.
4. Argos, P., Narayana, S.V.L. and Nielsen, N.C. 1985. Structural similarity between legumin and vicilin storage proteins from legumes. *EMBO J.* 4: 1111-1117.
5. Arora, S.K. and Luthra, Y.P. 1971. Relationship between sulphur content of leaf with methionine, cysteine and cysteine contents in the seeds of *Phaseolus aureus* L. as affected by S, P, and N application. *Plant and Soil* 34: 91-96.
6. Badenoch-Jones, J., Spencer, D., Higgins, T.J.V. and Millerd, A. 1981. The role of glycosylation in storage-protein synthesis in developing pea seeds. *Planta* 153: 201-209.
7. Barker, S.J., Harada, J.J. and Goldberg, R.B. 1988. Cellular localization of soybean storage protein mRNA in transformed tobacco seeds. *Proc. Nat. Acad. Sci. U.S.A.* 85: 458-462.
8. Beach, L.R., Spencer, D., Randall, P.J. and Higgins, T.J.V. 1985. Transcriptional and post-transcriptional regulation of storage protein gene expression in sulfur-deficient pea seeds. *Nucleic Acids Res.* 13: 999-1012.

9. Beachy, R.N., Chen, Z.L., Horsch, R.B., Rogers, S.G., Hoffmann, N.J. and Fraley, R.T. 1985. Accumulation and assembly of soybean  $\beta$ -conglycinin in seeds of transformed petunia plants. *EMBO J.* 4: 3047-3053.
10. Bianchi, M.W. and Viotti, A. 1988. DNA methylation and tissue-specific transcription of the storage protein genes of maize. *Plant Mol. Biol.* 11: 203-214.
11. Blagrove, R.J., Gillespie, J.M. and Randall, P.J. 1976. Effect of sulphur supply on the seed globulin composition of *Lupinus angustifolius*. *Aust. J. Plant Physiol.* 3: 173-184.
12. Bray, E.A. and Beachy, R.N. 1985. Regulation by ABA of  $\beta$ -conglycinin expression in cultured developing soybean cotyledons. *Plant Physiol.* 79: 746-750.
13. Bray, E.A., Naito, S., Pan, N.S., Anderson, E., Dube, P. and Beachy, R.N. 1987. Expression of the  $\beta$ -subunit of  $\beta$ -conglycinin in seeds of transgenic plants. *Planta* 172: 364-370.
14. Cantoni, G.L. and Razin, A. 1985. Biochemistry and biology of DNA methylation, pp. 1-340. New York: Alan R. Liss.
15. Chandler, P.M., Higgins, T.J.V., Randall, P.J. and Spencer, D. 1983. Regulation of legumin levels in developing pea seeds under conditions of sulfur deficiency. *Plant Physiol.* 71: 47-54.
16. Chandler, P.M., Spencer, D., Randall, P.J. and Higgins, T.J.V. 1984. Influence of sulfur nutrition on developmental patterns of some major pea seed proteins and their mRNAs. *Plant Physiol.* 75: 651-657.
17. Chen, Z.L., Pan, N.S. and Beachy, R.N. 1988. A DNA sequence element that confers seed-specific enhancement to a constitutive promoter. *EMBO J.* 7: 297-302.
18. Chen, Z.L., Schuler, M.A. and Beachy, R.N. 1986. Functional analysis of regulatory elements in a plant embryo-specific gene. *Proc. Nat. Acad. Sci. U.S.A.* 83: 8560-8564.
19. Cho, T.-J., Davies, C.S. and Nielsen, N.C. 1989. Inheritance and organization of glycinin genes in soybean. *Plant Cell* 1: 329-337.
20. Chrispeels, M.J., Higgins, T.J.V. and Spencer, D. 1982. Assembly of storage protein oligomers in the endoplasmic reticulum and processing of the polypeptides in the protein bodies of developing pea cotyledons. *J. Cell Biol.* 93: 306-313.
21. Coates, J.B., Medeiros, J.S., Thanh, V.H. and Nielsen, N.C. 1985. Characterization of the subunits of  $\beta$ -conglycinin. *Arch. Biochem. Biophys.* 243: 184-194.
22. Craig, S., Goodchild, D.J. and Miller, A. 1979. Immunofluorescent localization of pea storage proteins in glycol methacrylate embedded tissue. *J. Histochem. Cytochem.* 27: 1312-1316.
23. Creason, G.L., Holowach, L.P., Thompson, J.F. and Madison, J.T. 1983. Exogenous methionine depresses level of mRNA for a soybean storage protein. *Biochem. Biophys. Res. Commun.* 117: 658-662.
24. Creason, G.L., Thompson, J.F. and Madison, J.T. 1985. Methionine analogs inhibit production of  $\beta$ -subunit of soybean 7S protein. *Phytochemistry* 24: 1147-1150.
25. Danielsson, C. E. 1949. Seed globulins of the Gramineae and Leguminosae. *Biochem. J.* 44: 387-400.
26. De Lumen, B.O. and Kho, C.-J. 1987. Identification of methionine-containing proteins and quantitation of their methionine contents. *J. Agr. Food Chem.* 35: 688-691.
27. Derbyshire, E., Wright, D.J. and Boulter, D. 1976. Legumin and vicilin, storage proteins of legume seeds. *Phytochemistry* 15: 3-24.
28. Domoney, C. and Casey, R. 1985. Measurement of gene number for seed storage proteins in *Pisum*. *Nucleic Acids Res.* 13: 687-699.
29. Doyle, J.J., Schuler, M.A., Godette, W.D., Zenger, V. and Beachy, R.N. 1986. The glycosylated seed storage proteins of *Glycine max* and *Phaseolus vulgaris*. Structural homologies of genes and proteins. *J. Biol. Chem.* 261: 9228-9238.
30. Eggum, B.O. and Beames, R.M. 1983. The nutritive value of seed proteins. In: *Seed proteins. Biochemistry, genetics, nutritive value*, Gottschalk, W. and Muller, H.P. eds., pp. 499-531, The Hague: Martinus Nijhoff.
31. Eppendorfer, W.H. 1971. Effects of S, N and P on amino acid composition of field beans (*Vicia faba*) and responses of the biological value of the seed protein to S-amino acid content. *J. Sci. Food Agr.* 22: 501-505.
32. Evans, I.M., Gatehouse, J.A., Croy, R.R.D. and Boulter, D. 1984. Regulation of the transcription of storage-protein mRNA in nuclei isolated from developing pea (*Pisum sativum* L.) cotyledons. *Planta* 160: 559-568.
33. FAO 1957. Protein requirements. FAO nutritional studies #16.
34. Gatehouse, J.A., Evans, I.M., Bown, D., Croy, R.R.D. and Boulter, D. 1982. Control of storage-

- protein synthesis during seed development in pea (*Pisum sativum* L.). *Biochem. J.* 208: 119-127.
35. Gatehouse, J.A., Evans, I.M., Croy, R.R.D. and Boulter, D. 1986. Differential expression of genes during legume seed development. *Phil. Trans. R. Soc. Lond.* B314: 367-384.
  36. Gatehouse, J.A., Lycett, G.W., Delauney, A.J., Croy, R.R.D. and Boulter, D. 1983. Sequence specificity of the post-translational proteolytic cleavage of vicilin, a seed storage protein of pea (*Pisum sativum* L.). *Biochem. J.* 212: 427-432.
  37. Gayler, K.R. and Sykes, G.E. 1981.  $\beta$ -Conglycinins in developing soybean seeds. *Plant Physiol.* 67: 958-961.
  38. Gayler, K.R. and Sykes, G.E. 1985. Effects of nutritional stress on the storage proteins of soybeans. *Plant Physiol.* 78: 582-585.
  39. Grabau, L.J., Blevins, D.G. and Minor, H.C. 1986. Stem infusions enhanced methionine content of soybean storage protein. *Plant Physiol.* 82: 1013-1018.
  40. Hammond, R.W., Foard, D.E. and Larkins, B.A. 1984. Molecular cloning and analysis of a gene coding for the Bowman-Birk protein. *J. Biol. Chem.* 259: 9883-9890.
  41. Harada, J.J., Barker, S.J. and Goldberg, R.B. 1989. Soybean  $\beta$ -conglycinin genes are clustered in several DNA regions and are regulated by transcriptional and posttranscriptional processes. *Plant Cell* 1: 415-425.
  42. Higgins, T.J.V., Chandler, P.M., Randall, P.J., Spencer, D., Beach, L.R., Blagrove, R.J., Kortt, A.A. and Inglis, A.S. 1986. Gene structure, protein structure, and regulation of the synthesis of a sulfur-rich protein in pea seeds. *J. Biol. Chem.* 261: 11124-11130.
  43. Holowach, L.P., Madison, J.T. and Thompson, J.F. 1986. Studies on the mechanism of regulation of the mRNA level for a soybean storage protein subunit by exogenous L-methionine. *Plant Physiol.* 80: 561-567.
  44. Holowach, L.P., Thompson, J.F. and Madison, J.T. 1984. Effect of exogenous methionine on storage protein composition of soybean cotyledons cultured *in vitro*. *Plant Physiol.* 74: 576-583.
  45. International Atomic Energy Agency. 1979. Seed improvement in cereals and legumes, vol.2, Vienna: IAEA.
  46. Jakubek, M. and Przybylska, J. 1979. Comparative study of seed proteins in the genus *Pisum* III. Electrophoretic patterns and amino acid composition of albumin fraction separated by gel filtration. *Genet. Pol.* 20: 369-379.
  47. Jofuku, K.D., Okamura, J.K. and Goldberg, R.B. 1987. Interaction of an embryo DNA binding protein with a soybean lectin gene upstream region. *Nature* 328: 734-737.
  48. Kirihara, J.A., Hunsperger, J.P., Mahoney, W.C. and Messing, J.W. 1988. Differential expression of a gene for a methionine-rich storage protein in maize. *Mol. Gen. Genet.* 211: 477-484.
  49. Kuhlmeier, C., Green, P.J. and Chua, N.H. 1987. Regulation of gene expression in higher plants. *Annu. Rev. Plant Physiol.* 38: 221-257.
  50. Ladin, B.F., Tierney, M.L., Meinke, D.W., Hosangadi, P., Veith, M. and Beachy, R.N. 1987. Developmental regulation of  $\beta$ -conglycinin in soybean axes and cotyledons. *Plant Physiol.* 84: 35-41.
  51. Lawton, M.A., Tierney, M.A., Nakamura, I., Anderson, E., Komeda, Y., Dube, P., Hoffman, N., Fraley, R.T. and Beachy, R.N. 1987. Expression of a soybean  $\beta$ -conglycinin gene under the control of the cauliflower mosaic virus 35S and 19S promoters in transformed petunia tissues. *Plant Mol. Biol.* 9: 315-324.
  52. Macnicol, P.K. 1983. Differential effect of sulphur deficiency on the composition of the aminoacyl-tRNA and free amino acid pools of the developing pea seed. *FEBS Lett.* 156: 55-57.
  53. Madison, J.T., Thompson, J.F. and Muenster, A.E. 1981. Turnover of storage proteins in seed of soya bean and pea. *Ann. Bot.* 47: 65-73.
  54. Meinke, D.W., Chen, J. and Beachy, R.N. 1981. Expression of storage-protein genes during soybean seed development. *Planta* 153: 130-139.
  55. Millerd, A., Thomson, J.A. and Randall, P.J. 1979. Heterogeneity of sulphur content in the storage proteins of pea cotyledons. *Planta* 146: 463-466.
  56. Naito, S., Dube, P.H. and Beachy, R.N. 1988. Differential expression of conglycinin  $\alpha'$  and  $\beta$  subunit genes in transgenic plants. *Plant Mol. Biol.* 11: 109-123.
  57. Ngerprasisriri, J., Kobayashi, H. and Akazawa, T. 1988. DNA methylation occurred around lowly expressed genes of plastid DNA during fruit development. *Plant Physiol.* 88: 16-20
  58. Nielsen, N.C., Dickinson, C.D., Cho, T.-J., Thanh, V.H., Scallan, B.J., Fischer, R.L., Sims, T.L., Drews, G.N. and Goldberg, R.B. 1989. Characterization of the glycinin gene family in soybean. *Plant Cell* 1: 313-328.

59. Odani, S. and Ikenaka, T. 1972. Studies on soybean trypsin inhibitors. IV. Complete amino acid sequence and the anti-proteinase sites of Bowman-Birk soybean proteinase inhibitor. *J. Biochem. (Tokyo)* 71: 839-848.
60. Okamuro, J.K., Jofuku, K.D. and Goldberg, R.B. 1986. Soybean seed lectin gene and flanking non-seed protein genes are developmentally regulated in transformed tobacco plants. *Proc. Nat. Acad. Sci. U.S.A.* 83: 8240-8244.
61. Payne, P.I. 1983. Breeding for protein quantity and protein quality in seed crops. In: *Seed proteins*, Daussant, J., Mosse, J. and Vaughn, J. eds., pp. 223-253, London: Academic Press.
62. Quebedeaux, B., Sweetser, P.B. and Rowell, J.C. 1976. Abscisic acid levels in soybean reproductive structures during development. *Plant Physiol.* 58: 363-366.
63. Rachis, J.J. and Gumbmann, M.R. 1981. Protease inhibitors: physiological properties and nutritional significance. Antinutrients and natural toxicants in foods, Ory, R.L. ed., pp. 203-237, Food and Nutrition Press, Westport, CT.
64. Randall, P.J., Thomson, J.A. and Schroeder, H.E. 1979. Cotyledonary storage proteins in *Pisum sativum*. IV. Effects of sulfur, phosphorus, potassium and magnesium deficiencies. *Aust. J. Plant Physiol.* 6: 11-24.
65. Rendig, V.V. 1986. Sulfur and crop quality. In: *Sulfur in agriculture*, Tabatabai, M.A. ed., pp. 635-652, Madison, WI: ASA, CSSA, SSSA.
66. Schroeder, H.E. 1984. Major albumins of *Pisum* cotyledons. *J. Sci. Food Agr.* 35: 191-198.
67. Schuler, M.A., Ladin, B.F., Polacco, J.C., Freyer, G. and Beachy, R.N. 1982. Structural sequences are conserved in the genes coding for the  $\alpha$ -,  $\alpha'$ - and  $\beta$ -subunits of the soybean 7S seed storage protein. *Nucleic Acids Res.* 10: 8245-8261.
68. Schuler, M.A., Schmitt, E.S. and Beachy, R.N. 1982. Closely related families of genes code for the  $\alpha$ - and  $\alpha'$ -subunits of the soybean 7S storage protein complex. *Nucleic Acids Res.* 10: 8225-8244.
69. Sengupta-Gopalan, C., Reichert, N.A., Barker, R.F., Hall, T.C. and Kemp, J.D. 1985. Developmentally regulated expression of the bean  $\beta$ -phaseolin gene in tobacco seed. *Proc. Nat. Acad. Sci. U.S.A.* 82: 3320-3324.
70. Sharma, G.C. and Bradford, R.R. 1973. Effect of sulfur on yield and amino acids of soybeans. *Comm. Soil Sci. Plant Anal.* 4: 77-82.
71. Shuttuck-Eidens, D.M. and Beachy, R.N. 1985. Degradation of  $\beta$ -conglycinin in early stages of soybean embryogenesis. *Plant Physiol.* 78: 895-898.
72. Sun, S.S.M., Leung, F.W. and Tomic, J.C. 1987. Brazil nut (*Bertholletia excelsa* J.B.K.) proteins: fractionation, composition, and identification of a sulfur-rich protein. *J. Agr. Food Chem.* 35: 232-235.
73. Sussex, I.M. and Dale, R.M.K. 1979. Hormonal control of storage protein synthesis in *Phaseolus vulgaris*. In: *The plant seed. Development, preservation and germination*, Rubenstein, I. ed., pp. 129-141, New York, NY: Academic Press.
74. Talbot, D.R., Adang, M.J., Slightom, J.L. and Hall, T.C. 1984. Size and organization of a multigene family encoding phaseolin, the major seed storage protein of *Phaseolus vulgaris* L. *Mol. Gen. Genet.* 198: 42-49.
75. Tan-Wilson, A.L., Chen, J.C., McGrain, A.K., Kiang, D. and Wilson, K.A. 1989. Temporal pattern of trypsin inhibitor accumulation in developing soybean seeds. *J. Agr. Food Chem.* 37: in press.
76. Thanh, V. and Shibasaki, K. 1977. Beta-conglycinin from soybean proteins. Isolation and immunological and physicochemical properties of the monomeric forms. *Biochim. Biophys. Acta* 490: 370-384.
77. Thanh, V. and Shibasaki, K. 1978. Major proteins of soybean seeds. Subunit structure of  $\beta$ -conglycinin. *J. Agr. Food Chem.* 26: 692-695.
78. Thompson, J.F., Madison, J.T. and Muenster, A.E. 1977. *In vitro* culture of immature cotyledons of soya bean (*Glycine max* L. Merr.). *Ann. Bot.* 41: 29-39.
79. Thompson, J.F., Madison, J.T., Waterman, M.A. and Muenster, A.E. 1981. Effect of methionine on growth and protein composition of cultured soybean cotyledons. *Phytochemistry* 20: 941-945.
80. Tierney, M.L., Bray, E.A., Allen, R.D., Ma, Y., Drong, R.F., Slightom, J. and Beachy, R.N. 1987. Isolation and characterization of a genomic clone encoding the  $\beta$ -subunit of  $\beta$ -conglycinin. *Planta* 172: 356-363.
81. Walling, L., Drews, G.N. and Goldberg, R.B. 1986. Transcriptional and post-transcriptional regulation of soybean seed protein mRNA levels. *Proc. Nat. Acad. Sci. U.S.A.* 83: 2123-2127.
82. Wilcke, H.L., Hopkins, D.T. and Waggle, D.H. 1979. Soybean protein and human nutrition, New York: Academic Press, pp. 1-406.
83. Youle, R.J. and Huang, A.H. 1981. Occurrence of low molecular weight and high cysteine-containing albumin storage proteins in oilseeds of diverse species. *Am. J. Bot.* 68: 44-48.

## DISCUSSION SECTION 3

The discussion centered around two topics. First, there was considerable discussion of the sulfate esters with special reference to glucosinolates and flavonoid sulfates. Second, the sulfur balance in plants was considered which included side excursions into nitrogen to sulfur ratio, into regulation of sulfate and nitrate reduction and uptake, and into sulfur supply.

Several aspects of glucosinolate physiology were covered. Most glucosinolates are synthesized throughout the plant. The major exception is the indole glucosinolates, sometimes termed 'storage glucosinolates', which are formed in the pod wall. These can then be transported around the plant (possibly in the phloem) as well as into the seed. The glucosinolates, other than the indole glucosinolates, can also be formed in the pod wall and imported into the seed, where they are stored. As the seed matures and dries out, glucosinolate synthesis ceases.

The most complex portion of glucosinolate biosynthetic pathway is the formation of the side chains that derive from amino acids. Some of the side chains are not related to any known amino acid, especially those with longer side chains. Apparently, some amino acids are elongated by an unknown mechanism. The precursor amino acids are decarboxylated and converted into glucosinolates in the seed. The biosynthesis requires ATP, NADPH etc. that could result in an energy drain on the plant. Although there is evidence that higher plants apparently do not lack for energy, high levels of glucosinolates can reduce flower and seed production. It is suggested that plants can regulate glucosinolate synthesis and thus avoid an adverse effect of excess glucosinolate formation. In rape seed, glucosinolates are responsible for about 0.7 % of the seed sulfur or about one quarter as much as the protein sulfur. Since glucosinolates are undesirable in rape seed, newer varieties have been developed that have a far lower content of glucosinolates. The glucosinolates occur primarily in higher plants and are found only in the *Cruciferae* and *Capparidaceae*. Although the glucosinolates are structurally similar to the cyanogenic glycosides, these two types of compounds are not found in the same plant.

There is good evidence that the oxidized sulfur of glucosinolates can be utilized by the plant, but utilization of the reduced sulfur is not certain. Plants can utilize the oxidized sulfur of glucosinolates when they are sulfur deficient.

The flavonoid sulfates occur primarily in marsh plants where they can account for up to 1 % of the sulfur. Even within a species, there are varieties that vary considerably in flavonoid sulfate content. Varieties that grow inland, e.g. may have no flavonoid sulfates whereas those that grow near the sea may have appreciable levels. These observations indicate that flavonoid sulfates may provide ecological advantages.

Determination of sulfur balance (input versus output) in plants is often poor because the input is considerably different from that found in the plant. The reason for this discrepancy is that plants can obtain an appreciable portion of their sulfur from the atmosphere, e.g. as sulfur dioxide, hydrogen sulfide, dimethyl sulfide and carbonyl sulfide. Dimethyl sulfide is produced mainly by marine algae and is oxidized in the atmosphere to sulfate. The sulfate forms aerosols which provide nuclei for

cloud formation. For this reason, the sulfur content of rain water is fairly constant so that the sulfate supplied to the plant from rain is closely related to the amount of rainfall. The soil is usually a more important source of sulfur than the atmosphere because the sulfur content of the ground water is higher than that of rain water. However, the weather patterns can make a marked difference in the sulfur supply. For example, in a prolonged wet period, more sulfur comes down in the rain, there is less evapotranspiration and the roots do not grow as deeply because of low oxygen content of the soil. Sulfur dioxide supplies more sulfur to plants in dry periods than in wet periods because it is oxidized in and on the leaf and utilized whereas sulfur dioxide that come with rain is largely washed away. If land is not used for agricultural purposes, where the plants are removed after harvest, sulfur will accumulate in plants (e.g. in forests). Soils do not bind sulfate as they do cations and organic matter, so a continuous supply of sulfur is important. This is one of the problems with lysimeter studies.

When experiments are carried out on the effect of supplying sulfur to plants by fumigation, the effectiveness can depend on the sulfur status of the plant because there is feedback regulation of pathways. One also has to remember that environmental conditions can markedly affect utilization of sulfur fumigants. This is important when experimental fumigation studies are conducted in the greenhouse and then the findings applied to field conditions where, for example, night temperatures may be much lower than in the greenhouse.

Many people use the ratio of nitrogen to sulfur as an indicator of sulfur status and general health of the plant. Nitrogen to sulfur ratio can be misleading because plants may vary in non-protein sulfur compounds. Hence each plant species has to be considered individually. A better measure would be protein level or the nitrogen to sulfur ratio of the protein fraction. However, protein content can be misleading; in *Lemna*, e.g., there is more protein when the nitrogen source is ammonia rather than nitrate. Also, there is evidence for cross regulation of nitrate and sulfate reduction and this could affect N/S. Some of the evidence for cross regulation could be due to simple feedback inhibition. There is evidence for feedback regulation of sulfate uptake.

Sulfur supply also interacts with hormones. Sulfur deficient plant have higher abscisic acid and this may be a stress response. Also, roots treated with ethylene have a higher thiol content.

In conclusion, it is clear that much more needs to be known about sulfur physiology of plants before sulfur compounds can be properly manipulated for the benefit of agriculture.

## Enter Contributions.



## Contents

4.1	C.I. Bell, W.J. Cram and D.T. Clarkson, Turnover of sulfate in leaf vacuoles limits retranslocation under sulfur stress	163
4.2	L. Bergmann and R. Hell, Determination and characterization of $\gamma$ -glutamylcysteine synthetase from higher plants	167
4.3	W. Bosma, G. Kamminga and L.J. De Kok, H <sub>2</sub> S-induced accumulation of sulfhydryl-compounds in leaves of plants under field and laboratory exposure	173
4.4	K.-J. Dietz and H. Busch, Intracellular compartmentation, utilization and transport of methionine in barley mesophyll cells	177
4.5	G. Ferrari, G. Cacco, A. Bottacin and M. Saccomani, Energetics of sulfate uptake by plants as related to previous sulfate availability	181
4.6	P.B. Goldsbrough, M.L. Mendum and S.C. Gupta, Effect of glutathione on phytochelatin synthesis and cadmium tolerance in tomato cells	185
4.7	D. Grill, H. Gутtenberger and E. Bermadinger, Thiol-content of plants depending on the altitude	191
4.8	A.S. Gupta, R.G. Alscher and D.C. McCune, Ozone exposure, glutathione levels and photosynthesis in hybrid poplar	195
4.9	S. Klapheck, I. Zimmer and H. Cosse, Glutathione and ascorbate participate in hydrogen peroxide degradation in germinating castor bean endosperm	199
4.10	K.F. Kleppinger-Sparace, J.B. Mudd and S.A. Sparace, Biosynthesis of plant sulfolipids	205
4.11	F.A. Krone, C. Mundt and J.D. Schwenn, Probing for PAPS-reductase in higher organisms by Southern blotting of genomic DNA with the cloned <i>cysH</i> gene from <i>Escherichia coli</i>	209
4.12	Karuna C. Lakkineni, T.V.R. Nair and Y.P. Abrol, S and N interaction in relation to H <sub>2</sub> S emission in some crop species	213
4.13	G.L. Lamoureux, E.P. Fuerst and D.G. Rusness, Selected aspects of glutathione conjugation research in herbicide metabolism and selectivity	217
4.14	K. Nagel, Physiological aspects of Cd-tolerance in <i>Chlamydomonas reinhardtii</i>	223
4.15	H. Pfanz, K.-J. Dietz, I. Weinerth and B. Oppmann, Detoxification of sulfur dioxide by apoplastic peroxidases	229
4.16	N.J. Robinson, E. Delhaize, W.P. Lindsay, J.M. Berger and P.J. Jackson, Regulation of poly( $\gamma$ -glutamylcysteinyl)glycine synthesis in <i>Datura innoxia</i> cell cultures	235
4.17	D. Schmutz, A. Rügsegger and C. Brunold, Effects of heavy metals on assimilatory sulfate reduction in pea roots	241
4.18	P. Schröder, D.G. Rusness and G.L. Lamoureux, Detoxification of xenobiotics in spruce trees is mediated by glutathione-S-transferases	245
4.19	R. Schupp and H. Rennenberg, Diurnal changes in the thiol composition of spruce needles	249
4.20	J.A.C. Verkleij, P.L.M. Koevoets, J. van't Riet, J.A. de Knecht and W.H.O. Ernst, The role of metal-binding compounds (phytochelatins) in the cadmium-tolerance mechanism of bladder campion ( <i>Silene vulgaris</i> )	255
4.21	T.L. Vierheller and I.K. Smith, Effect of chilling on glutathione reductase and total glutathione in soybean leaves ( <i>Glycine max</i> (L) Merr)	261

# TURNOVER OF SULFATE IN LEAF VACUOLES LIMITS RETRANSLOCATION UNDER SULFUR STRESS

Christopher I. Bell<sup>1</sup>, W.J. Cram<sup>1</sup>, and D.T. Clarkson<sup>2</sup>

<sup>1</sup> Department of Biology, The University, Newcastle upon Tyne, U.K. NE1 7RU;

<sup>2</sup> Long Ashton Research Station, Bristol, U.K. BS18 9AF

*Estimations of the vacuolar turnover of sulfate from compartmental analysis of tracer exchange kinetics in excised tissue and from net chemical analysis of sulfate fluxes in intact plants have shown that roots turn over sulfate at between 5 and 7 times the rate in leaves. This finding provides some explanation as to why sulfate appears immobile when a plant is subjected to sulfur stress.*

With extended periods of S-deficiency it is frequently seen that older leaves remain green whilst the young leaves become pale. Previous experiments have shown that even when sulfur limited growth plants contained 16% of their total sulfur as sulfate, mostly being retained in the older leaves<sup>1</sup>. In contrast  $\text{SO}_4^{2-}$  accumulated in the roots is readily retranslocated during S-starvation. Other available evidence suggests enzyme activities in the S-reducing pathway are not repressed in leaves under S-limited conditions. Secondly, phloem transport probably does not limit export from leaves under these conditions. It is reasonable to conclude therefore that, even with a powerful stress-produced sink (S-deficient plants), sulfate in leaf cells is just not available for reduction and retranslocation to growing tissues (unlike N, P and K). Work on carrot tissue suggests that the flux of  $\text{SO}_4^{2-}$  from the vacuole to the cytoplasm ( $\Phi_{vc}$ ) is less than the flux from the cytoplasm outwards ( $\Phi_{co}$ ) and thus may be a limiting step in the release and redistribution of sulfate<sup>1</sup>. If so, the rate of loss of vacuolar sulfate must be greater in roots than in leaves.

In this study compartmental analysis of radioactive exchange kinetics in wheat and in the legume *Macroptilium atropurpureum* has been used to test the hypothesis.

From the work of Clarkson *et al.*<sup>1</sup> it has been possible to estimate values for  $k_v$  (the rate constant for 'vacuolar' turnover of sulfate) in intact plants of *M. atropurpureum* when the plants were subjected to minus sulfate conditions. Table 1 shows that 7 to 8-fold differences in  $k_v$  could reasonably be expected between roots and leaves.

Compartmental analysis of tracer exchange kinetics in excised tissue has provided values of  $k_v$  in roots and leaves. Table 2 shows that differences in  $k_v$  were found to be comparable to those found in Table 1.

As can be seen from Table 2 the  $k_v$  values show a 5-10 fold difference between roots and leaves. This agrees with the estimates obtained from analysing redistribution of sulfate during S-starvation, though the absolute values for  $k_v$  do vary when estimated by the two methods.

In addition to estimating vacuolar sulfate turnover in roots and leaves the effect of changing external sulfate concentration on the  $\text{SO}_4^{2-}$  tracer flux in excised root tissue was investigated. Figure 1 shows that increasing the external  $\text{SO}_4^{2-}$  from 0.25 to 10 mM rapidly stimulates efflux across the plasmalemma. An 8 fold increase in the

**Table 1.**  $k_v$  values for the loss of sulfate in *M. atropurpureum* over a 3d period. Values were estimated from net chemical analysis of tissues after the removal of external sulfate. The table shows a 7-8 fold greater value for  $k_v$  in roots when compared to leaves. For experimental methods see Clarkson *et al.*<sup>1</sup>.

Plant tissue	SO <sub>4</sub> <sup>2-</sup> content ( $\mu$ Mol.) Od(-S); 3d(-S)	Change in content ( $\mu$ Mol)	$k_v$ (h <sup>-1</sup> ) (rate of loss/ average content)
Roots	5.80; 1.22	-4.58	$3.6 \cdot 10^{-2}$
Older leaves	1.43; 3.60	+2.17	$5 \cdot 10^{-2}$

\* Even though the older leaves actually gained SO<sub>4</sub><sup>2-</sup> over the 3d period a theoretical  $k_v$  for loss can still be estimated as follows: 1. From previous experiments it has been estimated that approximately 40% of the sulfate leaving the root under steady state conditions is transported via the xylem and 60% is lost to the external solution (Bell *et al.* unpublished). 2. If these relative fluxes were the same under -S conditions then over the 3d period in the above experiment 1.83 of the 4.58  $\mu$ Mol SO<sub>4</sub><sup>2-</sup> actually lost by the roots would have been transported to the shoot. 3. This being the case the sulfate lost from the roots (1.83  $\mu$ Mol) approximately equals the increase in the older leaves (2.17  $\mu$ Mol). 4. However, from the results presented in Fig. 2, it is likely that under -S conditions the flux across the plasmalemma to the external solution is less leading to more sulfate being transported through the xylem and entering the older leaves than might have been estimated purely from the above calculations. 5. Under these conditions it is reasonable to assume that more sulfate enters the leaves than is detected by net chemical analysis implying some turnover in the older leaves and retranslocation to other tissues. If this were 5% per day then this would correspond to the  $k_v$  value presented in Table 2.

**Table 2.**  $k_v$  values ('vacuolar' turnover) of sulfate in *M. atropurpureum* and wheat under steady state conditions. The table shows a 5-fold difference in  $k_v$  in *M. atropurpureum* between roots and leaves and a 7-fold difference in wheat, in qualitative agreement with the prediction in Table 1. Methods: 100 mg (approx.) of excised root or leaf tissue was labelled with <sup>35</sup>S sulfate overnight then washed out in successive 15 ml aliquots of aerated unlabelled culture solution. Standard 'curve peeling' (e.g. Cram 1968)<sup>2</sup> revealed three exponential components. The slowest of these was interpreted as corresponding to the vacuolar compartment, the intermediate to the cytoplasmic compartment, and the fastest to the extracellular compartment. For all experiments described in this paper plants were grown (and experiments were performed) at 0.25 mM SO<sub>4</sub><sup>2-</sup>. Fluxes and internal concentrations were estimated by standard methods (e.g. Cram 1968)<sup>2</sup>. SO<sub>4</sub><sup>2-</sup> concentrations were estimated as described by Tabatabai and Bremner (1970)<sup>4</sup>.

Plant species/tissue	$k_v$ (h <sup>-1</sup> ) $\pm$ SEM	t <sup>1/2</sup> (min)
<i>M. atropurpureum</i>		
Roots	$17.97 \pm 3.8$ ( $\times 10^{-2}$ )	230
<i>M. atropurpureum</i>		
Leaves	$3.41 \pm 0.4$ ( $\times 10^{-2}$ )	1200
Wheat		
Roots	$6.40 \pm 1.2$ ( $\times 10^{-2}$ )	650
Leaves	$4.44 \pm 0.8$ ( $\times 10^{-3}$ )	9350

rate of loss of tracer was observed within 5 minutes of increasing the external SO<sub>4</sub><sup>2-</sup> concentration. This is much faster than the cytoplasmic turnover in *M. atropurpureum* roots and thus the effect cannot be due to an increasing cytoplasmic content. The simplest explanation is that the increase in external concentration stimulates recycling across the plasmalemma.

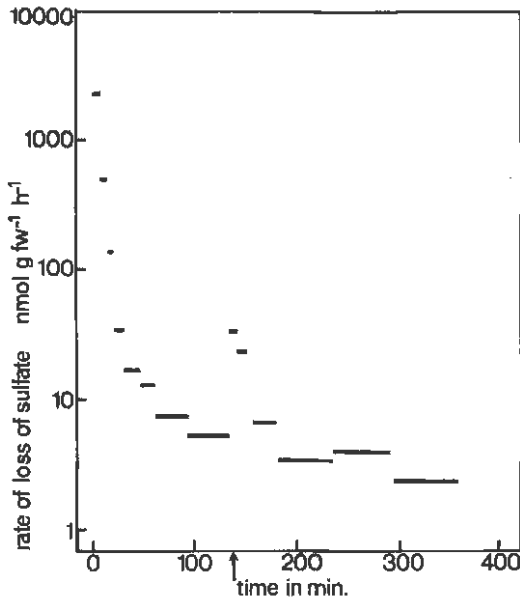

Fig. 1. *M. atropurpureum* root tissue labelled with <sup>35</sup>S sulfate overnight then washed out for 135 min. with 0.25 mM external SO<sub>4</sub><sup>2-</sup> followed by a further 225 min. with 10 mM SO<sub>4</sub><sup>2-</sup>. The arrow shows when the washout solution was changed from 0.25 to 10 mM SO<sub>4</sub><sup>2-</sup>. Methods: as described in Table 2.

In conclusion it would appear that the slow 'vacuolar' turnover of sulfate in leaves in *M. atropurpureum* (and in wheat) limits retranslocation of sulfate under sulfur stress. This may provide some explanation for the relative immobility of sulfate observed in many S-deficient plant species.

## References

1. Clarkson, D.T., Smith, F.W. and Vanden Berg, P.J. 1983. *J. Exp. Bot.* 34: 1463-1483.
2. Cram, W.J. 1968. *Biochim. Biophys. Acta* 163: 339-353.
3. Cram, W.J. 1983. *Plant Sci. Lett.* 31: 329-338.
4. Tabatabai, M.A. and Bremner, J.M. 1970. *Agron. J.* 62: 805-806.

# DETERMINATION AND CHARACTERIZATION OF $\gamma$ -GLUTAMYL-CYSTEINE SYNTHETASE FROM HIGHER PLANTS

L. Bergmann and R. Hell

Botanisches Institut der Universität zu Köln, Gyrhofstrasse 15, D-5000 Köln 41, F.R.G.

*The first step of glutathione synthesis, catalysed by  $\gamma$ -glutamylcysteine synthetase (EC 6.3.2.2.) has been analysed in partially purified enzyme preparations from cell suspension cultures of *Nicotiana tabacum*. Enzyme activity was determined by HPLC quantification of synthesized  $\gamma$ -glutamylcysteine as its monobromobimane derivative. The enzyme had an apparent  $M_r$  of 60 kDa. It showed greatest activity at pH 8.0 and an absolute requirement for  $Mg^{2+}$ . Treatment with dithioerythritol led to dissociation into subunits ( $M_r = 34$  kDa) and a heavy loss of activity. The apparent  $K_m$  values for cysteine,  $\alpha$ -aminobutyrate, and glutamate were, respectively, 0.15–0.2 mM, 5–7 mM, and 8–11 mM. The enzyme was competitively inhibited by glutathione ( $K_i = 0.4$ –0.6 mM). These data indicate that the rate of glutathione synthesis in vivo is probably influenced significantly by the intracellular concentrations of cysteine and glutamate and may be further regulated via feedback inhibition of  $\gamma$ -glutamylcysteine synthetase by glutathione itself.*

The first step in glutathione synthesis is the ATP-dependent formation of the dipeptide  $\gamma$ -glutamylcysteine ( $\gamma$ -GC) from glutamic acid and cysteine (1).



This reaction is catalysed by  $\gamma$ -glutamylcysteine synthetase (EC 6.3.2.2.). The enzyme has thoroughly been studied in animals and microorganisms<sup>1</sup>, where it apparently catalyses the rate limiting step in glutathione synthesis<sup>2</sup>. In plants, there is only a study by Webster and Varner<sup>3</sup> on the mechanism of  $\gamma$ -GC synthesis in wheat germ, which has never been confirmed, and a preliminary report indicating the presence of  $\gamma$ -GC synthetase in cultured tomato cells<sup>4</sup>. Therefore, we have employed the technique used for the determination of glutathione synthetase<sup>5</sup> to determine and to characterize  $\gamma$ -GC synthetase from suspension cultures of *Nicotiana tabacum*. This technique takes advantage of a method described by Newton et al.<sup>6</sup> for the determination of biological thiols at the picomol level. The determination is based on conversion of thiols to fluorescent derivatives by reaction with monobromobimane, separation of derivatives by reverse phase HPLC and quantification by fluorometry.

Although crude homogenates of tobacco cells showed high activity of GSH synthetase<sup>5</sup>,  $\gamma$ -GC synthetase activity was only detected after dialysis or ammonium sulfate precipitation of the extract. Addition of the antioxidants dithioerythritol or mercaptoethanol to homogenization buffer or assay mixture led to irreproducible results. Under anaerobic conditions, preventing losses of cysteine by oxidation, the formation of  $\gamma$ -GC and the simultaneous consumption of cysteine could be followed in the assays as shown in Fig. 1.

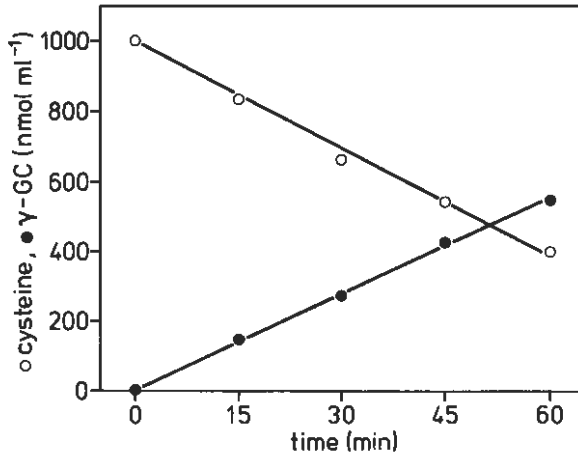

Fig. 1. Synthesis of  $\gamma$ -glutamylcysteine by  $\gamma$ -GC synthetase from *N. tabacum*.  $\gamma$ -GC synthetase was extracted from plant material by homogenization with 0.1 M TRIS-HCl, pH 7.5, 5 mM EDTA and polyvinylpyrrolidone (1 g / 25 ml). High-speed supernatants of the homogenates were subjected to ammonium sulfate precipitation (35–60 % saturation), the enzyme was further concentrated by Sephacryl S 200 filtration. 1.65 mg Protein were incubated under argon at pH 8.0 (0.1 M HEPES-NaOH) with 1 mM L-cysteine, 20 mM L-glutamate, 4 mM ATP, an ATP regenerating system (8 mM phosphocreatine, 10 U of creatinphosphokinase, Boehringer), and 50 mM  $MgCl_2$  in a total volume of 1 ml at 30°C.  $\gamma$ -Glutamylcysteine and cysteine were determined as monobromobimane derivatives by reverse phase HPLC as described<sup>5</sup>. The values represent means of 4 replicates.

The complications arising from the oxidation of cysteine may also be avoided by using L- $\alpha$ -aminobutyrate instead of cysteine as a substrate<sup>7</sup>. The determination of the product,  $\gamma$ -glutamyl- $\alpha$ -aminobutyrate, by derivatization with OPA-reagent followed by reverse phase HPLC and fluorescence detection<sup>8</sup> is as sensitive as the determination of the bimane derivative of  $\gamma$ -GC, and about equal rates of reaction were found with saturating levels of cysteine and  $\alpha$ -aminobutyrate. However,  $\alpha$ -aminobutyrate concentrations of at least 20 mM and glutamate concentrations of 20 mM are needed to obtain saturating conditions; these high substrate concentrations cause significant difficulties in the product determination by pre-column OPA-derivatization.

Using ammonium sulfate precipitates at 90 % saturation, enzyme activities of 0.6–1.2 nmol (mg prot)<sup>-1</sup> min<sup>-1</sup> were obtained with cysteine as substrate. Fractionated ammonium sulfate precipitation (35–60 %) resulted in a twofold increase in specific activity of the enzyme; by gel filtration on Sephacryl S 200, a 4–5 fold purification as compared to ammonium sulfate precipitation at 90% saturation was achieved. Attempts to further purify the enzyme by affinity chromatography led to rapid losses of activity.

Using gel filtration on Ultrogel AcA 44,  $\gamma$ -GC synthetase was found to have a molecular weight of about 60 kDa (Fig. 2). This molecular weight is much lower than that observed for the enzyme from rat kidney<sup>9</sup> and *Candida*<sup>10</sup>. Enzymes from these sources showed molecular weights of 104 kDa and 124 kDa, respectively; they consisted of two subunits with 73 kDa and 27.7 kDa molecular weight (rat kidney) and two subunits of equal size with 60 kDa molecular weight (*Candida boidinii*). Treat-

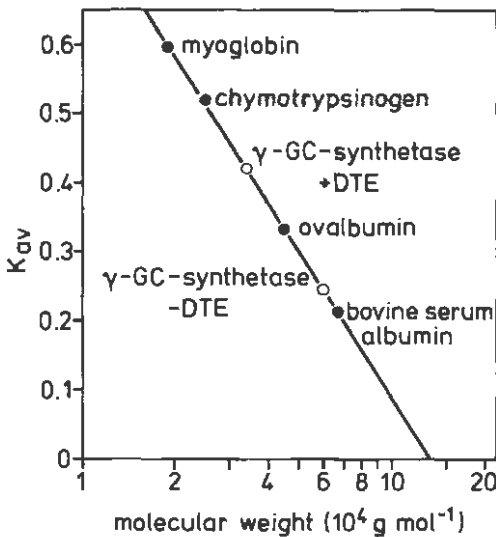

Fig. 2. Effect of treatment with dithioerythritol on the molecular weight of  $\gamma$ -GC synthetase.  $M_r$  was determined by means of filtration through an Ultrogel AcA 44 column (1.6 x 95 cm). Ammonium sulfate precipitates (35 – 60 % saturation) were dialysed against 50 mM K-phosphate buffer, pH 7.0, 1 mM EDTA, with and without 1 mM dithioerythritol in the cold for 6 hrs. About 30 mg of protein were applied to the column equilibrated with the corresponding buffer. Fractions of 3.3 ml were collected, concentrated by ultrafiltration and  $\gamma$ -GC synthetase activity determined in standard assays.

ment of the tobacco enzyme with dithioerythritol leads to dissociation into subunits with a molecular weight of app. 34 kDa accompanied by a heavy loss of activity (5 mM DTE, 30 min: 79% decrease in activity). A similar loss of activity was observed by treatment of the enzyme with mercaptoethanol (5 mM MeSH, 30 min: 46% decrease in activity), but the molecular weight of the enzyme under this condition has not yet been examined.

The enzyme showed optimal activity at pH 8.0 with cysteine as well as with  $\alpha$ -aminobutyrate as a substrate. At pH 7.0–7.2, the approximate pH of the chloroplast stroma in the dark, 40–60 % of the maximum activity were measured. In TRIS-HCl-, HEPES-NaOH- and CHES-NaOH-buffer nearly equal enzyme activities were observed.

$\text{Mg}^{2+}$  was found to be essential for enzyme activity. In contrast to GSH synthetase from tobacco cells which is fully activated by 10 mM  $\text{Mg}^{2+}$  and slightly stimulated by  $\text{K}^+$ , four times higher magnesium concentrations are required to fully activate  $\gamma$ -GC synthetase and the enzyme is not stimulated by  $\text{K}^+$ .

With increasing concentration of L-glutamate, L-cysteine, and L- $\alpha$ -aminobutyrate the initial rates of enzyme reaction showed saturation kinetics. In assays containing 4 mM ATP, 50 mM  $\text{MgCl}_2$  and 1 mM cysteine or 20 mM glutamate at varying concentrations of the other substrate, Lineweaver-Burk plots revealed apparent  $K_m$ -values as follows: L-glutamate, 8–10 mM; L-cysteine, 0.15–0.2 mM; L- $\alpha$ -aminobutyrate, 5–7 mM.

As has been shown for the  $\gamma$ -GC synthetase from erythrocytes<sup>11</sup> and rat kidney<sup>2</sup> the tobacco enzyme is inhibited by glutathione at concentrations similar to those

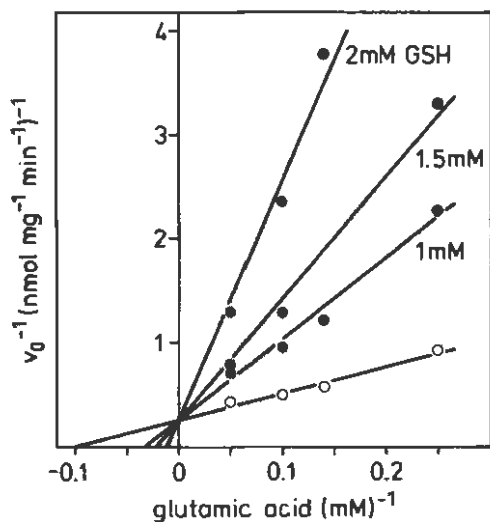

Fig. 3. Effect of L-glutamate on inhibition of  $\gamma$ -GC synthetase by glutathione. The reaction mixtures contained 0.1 M Hepes-NaOH buffer, pH 8.0, 1 mM L-cysteine, 4 mM ATP, an ATP-regenerating system (8 mM phosphocreatine, 10 U of creatinphosphokinase, Boehringer), 50 mM  $MgCl_2$ , and L-glutamate and glutathione as indicated in a total volume of 1 ml, all incubated for 30 min at 30°C under argon.  $\gamma$ -GC formed was determined as monobromobimane derivative by reverse phase HPLC<sup>5</sup>.

which prevail *in vivo*. The inhibition proved to be competitive with respect to glutamate (Fig. 3). The apparent  $K_i$  values for GSH calculated from these data are in the range of 0.4–0.6 mM. They strongly suggest that glutathione plays a significant role in the regulation of  $\gamma$ -GC synthesis in tobacco cells *in vivo*.

The method used for determination of  $\gamma$ -GC synthetase activity in cell suspensions from *Nicotiana tabacum* has also been successfully applied to assay  $\gamma$ -GC synthetase activity in leaf tissues of *Pisum sativum*, *Spinacia oleracea*, and *Triticum aestivum*, and should prove to be a reliable tool in further studies.

The results presented here clearly indicate that  $\gamma$ -GC synthesis *in vivo* can be modulated by several factors. The high  $K_m$  values for glutamate obtained in our experiments differ considerably from the data (1.2 mM) reported by Webster and Varner<sup>3</sup>. They imply that  $\gamma$ -GC synthesis in tobacco cells may be limited by the availability of glutamate. The synthesis rate may also be limited by the availability of cysteine. Our experiments in which cysteine levels were carefully monitored revealed an apparent  $K_m$  for cysteine (0.15 – 0.2 mM) which corresponds well with substrate affinities observed for  $\gamma$ -GC synthetase from animal cells<sup>2,11,12,13</sup>. This value of the tobacco enzyme is at least 25 times smaller than the value of 4.5 mM reported for the enzyme of wheat germ<sup>3</sup> and is probably not too far from the intracellular cysteine concentration in leaf tissues<sup>16</sup>. The rate of synthesis may be further modulated by the  $Mg^{2+}$  concentration and the pH of the cells, especially in the chloroplast stroma, where light-dependent changes of both factors occur<sup>14</sup>. Additionally, glutathione itself may play a significant role in the regulation of its synthesis by feedback inhibition of  $\gamma$ -GC synthetase as glutathione *in vitro* mediates substantial inhibition in concentrations found in plant cells<sup>15</sup>. It is evident that *in vivo* experiments are needed to



identify the factors modulating  $\gamma$ -GC formation in plant cells and to learn about the interrelation of these parameters.

Financial support of this investigation by the Deutsche Forschungsgemeinschaft is gratefully acknowledged.

## References

1. Meister, A. and Anderson, M.E. 1983. *Annu. Rev. Biochem.* 52: 711-760.
2. Richman, P.G. and Meister, A. 1975. *J. Biol. Chem.* 250: 1422-1426.
3. Webster, G.C. and Varner, J.E. 1954. *Arch. Biochem. Biophys.* 52: 22-32.
4. Steffens, J.C. and Williams, B. 1987. *Plant Physiol.* 83 (Suppl.): 666.
5. Hell, R. and Bergmann, L. 1988. *Physiol. Plant.* 72: 70-76.
6. Newton, G.L., Dorian, R. and Fahey, R.C. 1981. *Anal. Biochem.* 114: 383-387.
7. Seelig, G.F. and Meister, A. 1985. *Methods in Enzymology* Vol. 113: 379-390.
8. Lenda, K. and Svenneby, G. 1980. *J. Chromatogr.* 198: 516-519.
9. Seelig, G.F., Simonsen, R.P. and Meister, A. 1984. *J. Biol. Chem.* 259: 9345-9347.
10. Dennda, G. and Kula, M.-R. 1986. *J. Biotechnol.* 4: 143-158.
11. Jackson, R.C. 1969. *Biochem. J.* 111: 309-315.
12. Wendel, A. and Flohe, L. 1972. *Z. Physiol. Chem.* 353: 523-530.
13. Rathbun, W.B. 1967. *Arch. Biochem. Biophys.* 122: 62-72.
14. Heldt, H.W. 1979. *Encyclopedia of Plant Physiol.*, New Series, vol. 6: 202-207, Springer, Berlin.
15. Rennenberg, H. 1982. *Phytochemistry* 21: 2771-2781.
16. De Kok, L.J., Buwalda, F. and Bosma, W. 1988. *J. Plant. Physiol.* 133: 502-505.

## **H<sub>2</sub>S-INDUCED ACCUMULATION OF SULFHYDRYL-COMPOUNDS IN LEAVES OF PLANTS UNDER FIELD AND LABORATORY EXPOSURE**

Wiebe Bosma, Giny Kamminga and Luit J. De Kok

*Department of Plant Physiology, University of Groningen, P.O. Box 14, 9750 AA Haren, The Netherlands*

*H<sub>2</sub>S is a sulfur-containing air pollutant of local importance. In the south-eastern part of the province of Groningen, The Netherlands, water pollution by organic material from farina factories is the cause of locally high levels of atmospheric H<sub>2</sub>S (sometimes even exceeding 1 µl l<sup>-1</sup>, Provinciale Waterstaat Groningen, unpublished results). The aim of the present study was to measure effects of H<sub>2</sub>S pollution under field conditions. Already at concentrations of 0.03 µl l<sup>-1</sup> H<sub>2</sub>S growth of crop-plants may be affected<sup>1,4,7</sup>. The content of water-soluble non-protein sulfhydryl compounds shows a clear response upon fumigation with H<sub>2</sub>S: within two hours an increase in the content of these sulfhydryl compounds was demonstrated<sup>2</sup>. In light the two most important water-soluble non-protein sulfhydryl compounds are glutathione (GSH) and cysteine<sup>3</sup>. Both glutathione and cysteine contents increase upon fumigation with H<sub>2</sub>S<sup>3</sup>.*

The present results show that fumigation of clover (*Trifolium pratense* cv. Mekra) and sugarbeet (*Beta vulgaris* cv. Monohill) with 0.05 µl l<sup>-1</sup> H<sub>2</sub>S resulted in a significant increase in water-soluble non-protein sulfhydryl compounds within 6 hours (Fig. 1). This increase was stronger for clover than for sugarbeet. An increase in H<sub>2</sub>S concentration from 0.1 to 0.585 µl l<sup>-1</sup> resulted in clover in an increase in the content of water-soluble non-protein sulfhydryl compounds of ± 20 % (Fig. 2). This was in contrast with the results obtained for spinach, where an increase in H<sub>2</sub>S-concentration from 0.1 to 0.5 µl l<sup>-1</sup> resulted in an increase in sulfhydryl content of more than 100 %<sup>6</sup>. The absolute increase of sulfhydryl content was greater at lower temperature but the relative increase compared to the control was temperature independent (Fig. 3).

The question arose whether the effects of H<sub>2</sub>S observed under laboratory conditions also appear in plants grown under field conditions in H<sub>2</sub>S-polluted areas. When plants (*Trifolium pratense* c.v. Mekra and *Spinacia oleracea* c.v. Estivato) grown in a climate controlled room, were placed on a field location with H<sub>2</sub>S pollution (average concentration was up to 0.15 µl l<sup>-1</sup>) for 3 or 4 days, the content of water-soluble non-protein sulfhydryl compounds showed a very strong increase compared to the unpolluted location (Table 1). This increase was up to 5-fold or more in spinach and 2- to 3-fold in clover. Similar to the experiments performed under laboratory conditions the content of both glutathione and cysteine increased. The relative increase of cysteine was stronger (10-fold) than for glutathione (2-fold). In spinach the cysteine content increased from 15 % to 45 % of total sulfhydryl content, whereas in clover this increase was from 2 % to 8 %.

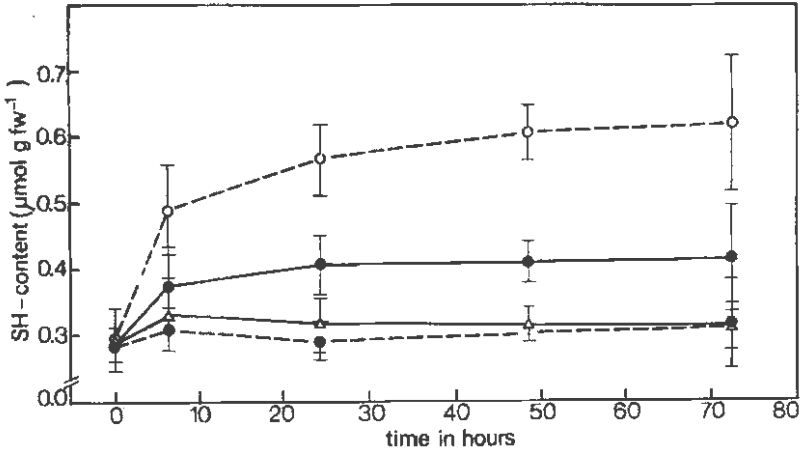

Fig. 1. The effect of 0.05 µl l<sup>-1</sup> H<sub>2</sub>S on the content of water-soluble non-protein sulfhydryl compounds in leaves of clover and sugarbeet. Plants were grown in climate controlled rooms for five and four weeks, respectively. Determination of sulfhydryl compounds was according to De Kok *et al.*<sup>3</sup>. Sulfhydryl content represents the mean of eight to fourteen measurements (± SD). Δ—Δ = clover, control, ○—○ = clover, 0.05 µl l<sup>-1</sup> H<sub>2</sub>S, ●—● = sugarbeet, control, ●—● = sugarbeet, 0.05 µl l<sup>-1</sup> H<sub>2</sub>S.

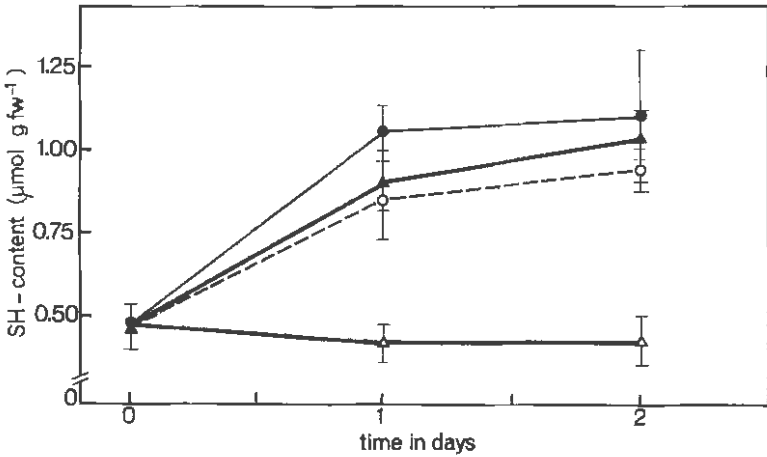

Fig. 2. The effect of H<sub>2</sub>S concentration on the content of water-soluble non-protein sulfhydryl compounds in the leaves of clover. Plants were grown in climate controlled rooms for five weeks. Determination of sulfhydryl compounds was according to De Kok *et al.*<sup>3</sup>. Sulfhydryl content represents the mean of six measurements (± SD). Δ—Δ = control, ○—○ = 0.1 µl l<sup>-1</sup> H<sub>2</sub>S, ▲—▲ = 0.285 µl l<sup>-1</sup> H<sub>2</sub>S, ●—● = 0.580 µl l<sup>-1</sup> H<sub>2</sub>S.

The present field experiments showed that the effect of H<sub>2</sub>S under field conditions are quite similar to that observed under laboratory conditions. A 5-fold increase in total water-soluble non-protein sulfhydryl content of spinach would indicate high levels of H<sub>2</sub>S (1 µl l<sup>-1</sup> and higher<sup>6</sup>). The measured average H<sub>2</sub>S concentration during the 3 or 4 day exposure period however did not exceed 0.15 µl l<sup>-1</sup>. The observed in-

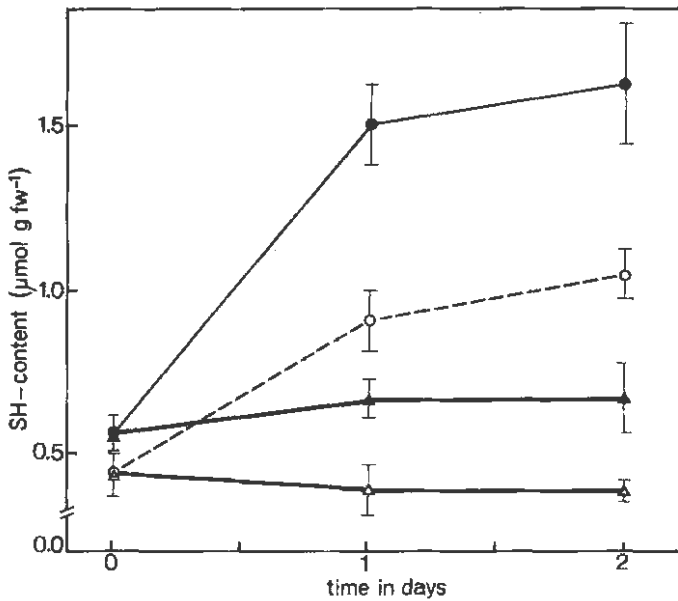

Fig. 3. The effect of temperature on the content of water-soluble non-protein sulfhydryl compounds in the leaves of clover upon fumigation with  $0.285 \mu\text{l l}^{-1}$   $\text{H}_2\text{S}$ . Plants were grown in climate controlled rooms for five weeks. Determination of sulfhydryl compounds was according to De Kok *et al.*<sup>3</sup>. Sulfhydryl content represents the mean of six measurements ( $\pm$  SD).  $\Delta$ — $\Delta$  =  $20^\circ\text{C}$ , control,  $\circ$ — $\circ$  =  $20^\circ\text{C}$ ,  $0.285 \mu\text{l l}^{-1}$   $\text{H}_2\text{S}$ ,  $\blacktriangle$ — $\blacktriangle$  =  $12^\circ\text{C}$ , control,  $\bullet$ — $\bullet$  =  $12^\circ\text{C}$ ,  $0.285 \mu\text{l l}^{-1}$   $\text{H}_2\text{S}$ .

Table 1. The effect of a three or four day field exposure to  $\text{H}_2\text{S}$  on the content of water-soluble non-protein sulfhydryl compounds and cysteine. The control location is situated near the Biological Center, Haren, The Netherlands and the polluted location is situated near Onstwedde, The Netherlands. Experiments were carried out during October/November 1988 and determination of water-soluble non-protein sulfhydryl compounds and cysteine were according to De Kok *et al.*<sup>3</sup>. Sulfhydryl and cysteine content are expressed as  $\mu\text{mol g frsh weight}^{-1}$  and represent the mean of eleven experiments ( $\pm$  SD).

		Unpolluted	$\text{H}_2\text{S}$ -polluted
Sulfhydryl content	Spinach	$0.37 \pm 0.09$	$1.47 \pm 0.56$
	Clover	$0.51 \pm 0.09$	$1.10 \pm 0.40$
Cysteine content	Spinach	$0.05 \pm 0.02$	$0.65 \pm 0.36$
	Clover	$0.01 \pm 0.00$	$0.08 \pm 0.07$

crease in cysteine content may indicate a disturbed sulfur metabolism due to excess sulfur<sup>3</sup>.

## References

- De Kok, L.J., Thompson, C.R., Mudd, J.B. and Kats, G. 1983. *Z. Pflanzenphysiol.* 111: 85-89.
- De Kok, L.J., Bosma, W., Maas, F.M. and Kuiper, P.J.C. 1985. *Plant, Cell and Environ.* 8: 189-194.
- De Kok, L.J., Buwalda, F. and Bosma, W. 1988. *J. Plant Physiol.* 133: 502-505.
- Krause, G.M.H. 1979. *Staub-Reinhalt. Luft* 39: 165-167.
- Maas, F.M., De Kok L.J. and Kuiper, P.J.C. 1985. *J. Plant Physiol.* 119: 219-226.
- Maas, F.M., De Kok, L.J., Strik-Timmer, W. and Kuiper, P.J.C. 1987. *Physiol. Plant.* 70: 722-728.
- Thompson, C.R. and Kats, G. 1978. *Environ. Sci. Technol.* 12: 550- 553.

# INTRACELLULAR COMPARTMENTATION, UTILIZATION AND TRANSPORT OF METHIONINE IN BARLEY MESOPHYLL CELLS

K.-J. Dietz and H. Busch

Lehrstuhl Botanik I, University of Würzburg, Mittlerer Dallenbergweg 64,  
D-6800 Würzburg, F.R.G.

*Mesophyll protoplasts from primary leaves of 10 day old barley plants contained about 1 mM methionine. [ $^{35}$ S]-methionine fed to leaves or protoplasts was rapidly incorporated into proteins indicating fast turnover of a small cytoplasmic pool of methionine which is separated from a larger vacuolar pool. Release of methionine from the vacuole was stimulated not only by ATP, but also by the ATP analogue AMP PNP (adenyl imidodiphosphate) which cannot energize transport. It was also stimulated by SH-blocking agents such as p-chloromercuriphenylsulfonic acid (pCMBS). ATP- and pCMBS-stimulation was also observed for uptake of [ $^{35}$ S]-methionine by vacuoles. Efflux was inhibited, when neutral amino acids were present outside the vacuole. It appears that the amino acid transporter(s) of the tonoplast is regulated on source/sink relationships. It permits efflux of amino acids from the vacuole, which acts as storage compartment, in response to amino acid demand in the cytosol.*

Under normal growth conditions of many plants, the main part of sulfur is in the reduced form. It is the constituent of the amino acids cysteine and methionine which are largely bound in protein. Sulfate accumulates only when excess sulfur is available<sup>1,2</sup>. Little is known about the compartmentation and intracellular transport of sulfur-containing amino acids. We investigated the compartmentation, utilization and transport of methionine in barley mesophyll protoplasts.

## Intracellular compartmentation of methionine

Barley plants were grown hydroponically in a standard nutrient solution containing 2 mM  $\text{SO}_4^{2-}$ . Mesophyll protoplasts and vacuoles<sup>3</sup> were isolated from 10 day old primary leaves and analyzed for amino acid contents with an amino acid analyzer (LC 5001, Biotronik, Germany). The methionine concentration was similar in protoplasts ( $1.33 \pm 0.22$  mM) and vacuoles ( $1.03 \pm 0.38$  mM). Some vacuolar methionine may have been lost during isolation of vacuoles (see Fig. 2), therefore the cytoplasmic methionine concentration may be close to the concentration of the vacuole. To understand the relationship between the cytoplasmic and the vacuolar pools, we here examined the utilization of methionine by protein synthesis. We have also characterized the transport of methionine across the tonoplast membrane.

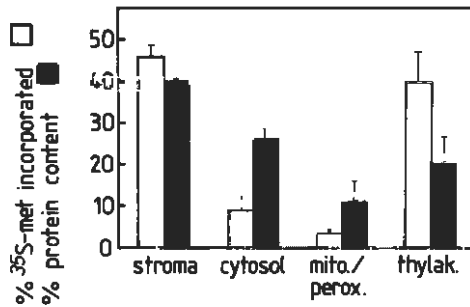

*Fig. 1.* Incorporation of [<sup>35</sup>S]-methionine and protein content of different compartments of mesophyll protoplasts. [<sup>35</sup>S]-methionine was fed to the leaves for 3h. Protoplasts<sup>3</sup> were isolated and fractionated with a membrane filtration technique<sup>4</sup>. The fractions were obtained by consecutive filtration of a protoplast lysate through an 8 μm (intact plastids are retained on the filter) and a 0.45 μm (mitochondria and peroxisomes are retained) nitrocellulose filter. The filtrate was enriched in cytosol. Marker enzymes were determined: glyceraldehyde-3-phosphate dehydrogenase (chloroplast), citrate synthase (mitochondria), glycolate oxidase (peroxisomes) and hexose-monophosphate isomerase (90% of its activity is contained in the cytosol of barley mesophyll protoplasts). The activities of citrate synthase and glycolate oxidase showed a similar distribution. Therefore, both compartments were combined for the calculations. Thylakoid membranes were prepared from chloroplasts by osmotic shock and repeated sedimentation. Protein contents and radioactivity were determined in all fractions. From the data of 3 experiments, protein content (closed columns) and [<sup>35</sup>S]-methionine incorporation (open columns) were calculated for the compartments<sup>4</sup> by Gauss elimination.

### Methionine utilization by protein synthesis

When [<sup>35</sup>S]-methionine (0.15 M) was fed to leaves via the transpiration stream or to mesophyll protoplasts, about 50% of the methionine taken up within 3h was incorporated into proteins. Figure 1 shows the relative incorporation of methionine into the protein of different cellular compartments in relation to the protein content of the compartments. Although more than 25% of the cellular protein was associated with the cytosol, only 10% of the total incorporated methionine was detected in the cytosol. In mitochondria and peroxisomes, incorporation of methionine into proteins was also slow in relation to available protein. In contrast, methionine incorporation into chloroplast proteins was fast. A comparable labeling of nucleus-encoded and plastome-encoded plastid proteins indicates efficient transport of methionine across the envelope membrane of plastids. In spinach, the large and small subunit of ribulose-1,5-bisphosphate carboxylase are labeled at a ratio of 4-5 when leaves are incubated with radioactive methionine. This value corresponds to the ratio in molecular mass of 4 (55 kDa/14 kDa). This shows that the methionine pools of the chloroplasts and of the cytosol exchange rapidly. These results give no information on the availability of vacuolar methionine for protein synthesis.

### Transport of methionine across the tonoplast membrane

Uptake and release of methionine were studied using isolated vacuoles. Figure 2A shows time-dependent uptake of 2 mM [<sup>35</sup>S]-methionine. (Specific activity: 0.4

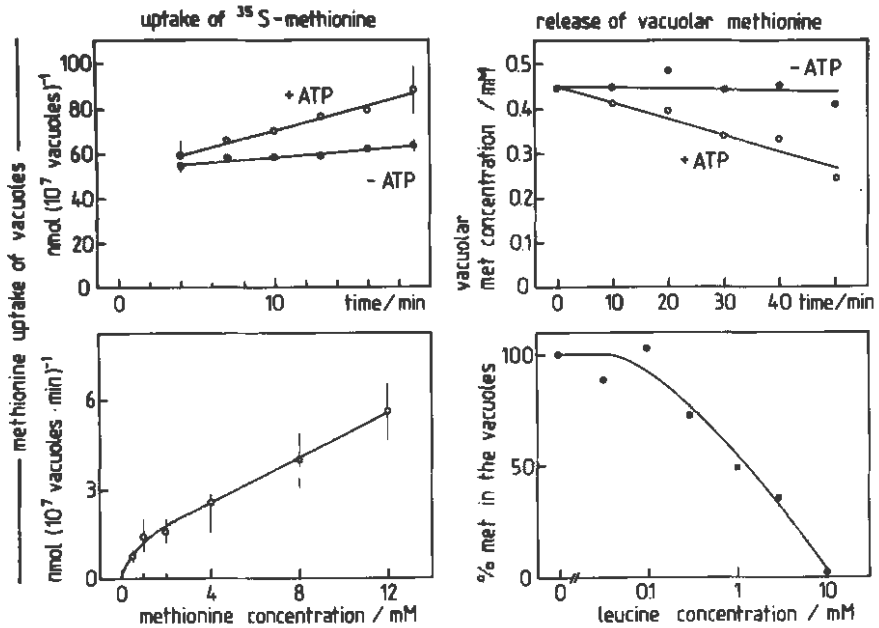

Fig. 2. Kinetics (A, upper left) and concentration dependence (B, lower left) of [ $^{35}\text{S}$ ]-methionine uptake by isolated vacuoles. Vacuoles were isolated. The incubation mixture contained 30 mM gluconate, 10 mM Hepes, pH 7.5, 40% (v/v) Percoll, 2mM dithiothreitol and 0.1% BSA<sup>5</sup>. Additionally, the medium contained  $^3\text{H}_2\text{O}$  and [ $^{35}\text{S}$ ]-methionine (300,000 dpm per 100  $\mu\text{l}$ -assay) and methionine. At the times indicated, the vacuoles were separated from the incubation medium by flotation through a layer of silicon oil. The recovery of vacuoles was quantified by the amount of  $^3\text{H}_2\text{O}$  in the upper aqueous phase. (C, upper right) and (D, lower right) show the kinetics of methionine release and the effect of increasing leucine concentrations on methionine release from isolated vacuoles. Vacuoles were incubated in the presence (○) and absence (●) of 10 mM ATP. Vacuoles were separated from the medium by flotation at the times indicated (C) or after 20 min of incubation (D). Efflux at various leucine concentrations is expressed as percent of maximum efflux in the absence of leucine. The ATP concentration was 10 mM. Other nucleotides had no or only a small stimulatory effect on methionine efflux.

Ci/mol). Uptake was linear in the time range of the experiment. A 3-fold stimulation was achieved by the addition of ATP. From the kinetics of uptake at various methionine concentrations, the concentration dependence of uptake in the presence of ATP was obtained (Fig. 2B). A saturating component could be distinguished from a non-saturating component. SH-reagents such as pCMBS increased the transport. Insensitivity of transport to the addition of 5 mM  $\text{NH}_4\text{Cl}$  shows that the uptake was not dependent on the transtonoplast pH (Table 1).

Figures 2C and 2D show the release of endogenous methionine from isolated vacuoles. Efflux appeared to be linear over a period of 50 min. It was stimulated by ATP. The neutral amino acid leucine inhibited the ATP-stimulated efflux (Fig. 2D). In the presence of 1 mM leucine, efflux of methionine was inhibited by 50%. Other neutral amino acids (isoleucine, valine, phenylalanine) also inhibited methionine efflux, whereas amino acids with small charged side chains (alanine, arginine, glutamic acid) were much less effective in decreasing amino acid efflux from the vacuoles (data not shown). SH-reagents such as pCMBS, N-ethylmaleimide or oxidized glutathione

**Table 1.** Uptake of [<sup>35</sup>S]-methionine by isolated vacuoles. Approximately 10<sup>5</sup> vacuoles were incubated as described in the legend to Fig. 2. The effects of 10 mM ATP, 1 mM pCMBS and 5mM NH<sub>4</sub>Cl were established by kinetic analysis as shown in Fig. 2A. From the slopes of 2 to 4 such experiments, rates of methionine uptake were derived. 10<sup>7</sup> vacuoles correspond to mesophyll protoplasts containing 1 mg chlorophyll.

	nmol methionine (10 <sup>7</sup> vacuoles min) <sup>-1</sup>
+ ATP	2.20 ± 0.40
- ATP	0.73 ± 0.41
+ ATP/pCMBS	3.05 ± 0.05
+ ATP/NH <sub>4</sub> Cl	2.67 ± 0.35

activated efflux. The transport appeared not to be energized by ATP, because the ATP analogue adenylyl imidodiphosphate (AMP PNP) which does not serve as substrate of the tonoplast ATPase also activated efflux. However, stimulation was somewhat lower; efflux in the presence of 10 mM AMP PNP was 50 % of the ATP-stimulated amino acid release.

The results indicate a considerable transport capacity of the tonoplast for methionine. It should be mentioned that the transporter is rather unspecific in respect to its amino acid substrates<sup>6</sup>. The rate of uptake in the presence of 1 mM methionine and 10 mM ATP was 1.4 nmol (10<sup>7</sup> vacuoles min)<sup>-1</sup>; the maximum rate of release observed was 4 nmol (10<sup>7</sup> vacuoles min)<sup>-1</sup>. In relation to normal rates of protein synthesis, these rates would allow a rapid exchange of methionine between the cytoplasmic and the vacuolar pools. In the *in vivo* labeling experiments, methionine fed to the leaves was efficiently incorporated into proteins. This suggests a separation of both pools. Obviously, the transporter at the tonoplast is under strong control and only activated to a level far below its optimum capacity. Regulation appears to be possible by changes in cytosolic amino acid concentrations (source/sink-relationship), by the adenylate system and possibly also by redox properties.

This work was supported within the Sonderforschungsbereich 176 of the Julius-Maximilians-Universität Würzburg. Technical assistance by Mrs. C. Zink is gratefully acknowledged.

## References

1. Giovanelli, J., Mudd, S.H. and Datko, A.H. 1980. in: The biochemistry of plants, Miñin, B.J. ed., Vol. 5, pp. 453-505, Academic Press, New York.
2. Rennenberg, H. 1984. *Annu. Rev. Plant Physiol.* 35: 121-153.
3. Kaiser, G. and Heber, U. 1984. *Planta* 161: 562-568.
4. Lilley, R., Stitt, M., Mader, G. and Heldt H.W. 1982. *Plant Physiol.* 70: 965-970.
5. Martinoia, E., Schramm, M.J., Kaiser, G., Kaiser, W.M. and Heber, U. 1986. *Plant Physiol.* 80: 895-901.
6. Dietz, K.-J., Martinoia, E. and Heber, U. 1989. *Biochim. Biophys. Acta*, 984: 57-62.



## ENERGETICS OF SULFATE UPTAKE BY PLANTS AS RELATED TO PREVIOUS SULFATE AVAILABILITY

G. Ferrari, G. Cacco\*, A. Bottacin\* and M. Saccomani

*Department of Agricultural Biotechnology, University of Padova, Italy; \* Istituto di Chimica Agraria, University of Reggio Calabria, Italy*

*Sulfate influx in Asparagus cells was not affected by cutoff of photosynthetic energy, while it was depressed by CN<sup>-</sup> and SHAM inhibition of respiratory O<sub>2</sub> uptake. The percent inhibition of sulfate uptake by 10<sup>-3</sup> M CN<sup>-</sup> and SHAM was 86 and 55, that of O<sub>2</sub> uptake 50 and 39 respectively, in accordance with the ATP yield. In maize seedlings the temperature coefficient for sulfate net influx was 2.1 during steady supply and 1.1 after sulfate deprivation. This suggests a modulation of energy coupling in response to previous availability of sulfate.*

Sulfate uptake by plant roots is conditioned by active transport across plasmalemma and tonoplast<sup>1</sup>, which requires coupling with processes yielding free energy, in order to overcome two kinds of potential gradient: electrical and chemical. The first one is common to the absorption of every anionic nutrient and depends on the general condition of plant metabolism; the second one depends specifically on the relative concentration of sulfate in the cytoplasm and in the nutrient medium. In the case of field crops, sulfate availability in the root environment may undergo large changes depending on the relative efficiency of uptake by roots and recovery from the soil towards the depletion zone.

Two questions are raised in the present work: the ability of various energy sources within the plant to drive sulfate transport; the possible modification of energy coupling in plants subjected to short periods of sulfate stress, in comparison with plants grown at steady state supply of sulfate.

The first question was faced by using *Asparagus* cell cultures, a biological system in which the two energy sources, deriving either from photosynthetic electron transport or from electron flow within the respiratory chain are both available inside each cell. Sulfate influx did not change when the photosynthetic source was excluded by removing light supply or by inhibiting electron flux with atrazine or diuron. On the contrary the inhibition of respiratory O<sub>2</sub> uptake by CN<sup>-</sup> or SHAM (salicyl hydroxamate) strongly affected sulfate influx, which dropped to 14 and 45 percent of control at 10<sup>-3</sup> M CN<sup>-</sup> and SHAM respectively. Sulfate uptake was more affected than O<sub>2</sub> uptake by the two inhibitors, showing therefore a strongly preferential attitude for coupling with the respiratory source of energy. Active influx of anions at the plasmalemma may depend on phosphate bond energy and in this case it must be driven by ATP hydrolysis. This dependence can be not obligatory, provided a direct coupling of transport with the respiratory redox chain is allowed<sup>3</sup>. In *Asparagus* cells the response of sulfate influx to inhibition by CN<sup>-</sup> and SHAM supplies good evidence for the dependence of sulfate uptake on ATP hydrolysis rather than on redox systems. In fact the ratio between the reduced levels (as percent of control) of

**Table 1.** Effect of  $\text{CN}^-$  and SHAM on respiratory  $\text{O}_2$  uptake (R) and  $\text{SO}_4^{2-}$  influx (I), in *Asparagus* single cells. Methods: Free mesophyll cells ( $5 \times 10^6$  cells/ml) were inoculated in the Jullien<sup>2</sup> medium, pH 5.8, containing  $^{35}\text{S}$ -labeled sulfate. The sulfate influx experiments were carried out at  $24^\circ\text{C}$  for 60 min. The cells were harvested by vacuum filtration on a Millipore filter ( $0.45 \mu$ ), washed three times with 10 ml of unlabeled cold medium. The collected cells were dissolved with dioxane in vials and  $^{35}\text{S}$  was evaluated in a Packard scintillator spectrometer. The respiratory oxygen uptake was measured at  $24^\circ\text{C}$  in a 4 ml cell, using a Clark-type  $\text{O}_2$  electrode.

INHIBITOR	percent inhibition		percent inhibition		I/R
	R		I		
CONTROL	100	0	100	0	1.0
$\text{CN}^- 10^{-4}$ M	78	12	55	45	0.7
$\text{CN}^- 10^{-3}$ M	50	50	14	86	0.3
SHAM $10^{-4}$ M	70	30	78	22	1.1
SHAM $10^{-3}$ M	61	39	45	55	0.7

**Table 2.** Sulfate influx ( $\Phi_{\text{oc}}$ ), net influx ( $J_{\text{oc}}$ ), translocation ( $\Phi_{\text{cx}}$ ), assimilation ( $J_{\text{cm}}$ ) and their temperature coefficient ( $Q_{10}$ ) between  $15^\circ$  and  $25^\circ\text{C}$  in roots of maize seedlings grown in condition of steady state nutrient supply or after 3 days sulfate deprivation. Flux data in  $\text{nmol h}^{-1} \cdot \text{g}^{-1}$  root f.w. Methods: Sulfate influx ( $\Phi_{\text{oc}}$ ) was determined in 9 day-old seedlings transferred to 1:10 Hoagland and Arnon solution<sup>5</sup> containing  $^{35}\text{S}$ -labeled sulfate. After 20 min, samples of roots were washed for 5 min with non-labeled medium, homogenized with an Ultraturrax apparatus and assayed for  $^{35}\text{S}$  by liquid scintillation spectrometry. Net influx ( $J_{\text{oc}}$ ) was evaluated by disappearance of sulfate from nutrient solution. Translocation to leaves ( $\Phi_{\text{cx}}$ ) and reduction rate ( $\Phi_{\text{cm}}$ ) were evaluated in 9-day-old seedlings transferred to  $^{35}\text{S}$ -labeled nutrient medium at the 8<sup>th</sup> day. After 10 h loading, roots and shoots were sampled at 30 min intervals for 14 h and assayed for  $^{35}\text{S}$  content. Inorganic  $^{35}\text{S}$ , was separated by the procedure of Smith<sup>7</sup>.

	Steady state			After deprivation		
	$15^\circ\text{C}$	$25^\circ\text{C}$	$Q_{10}$	$15^\circ\text{C}$	$25^\circ\text{C}$	$Q_{10}$
$\Phi_{\text{oc}}$	134	217	1.6	1180	1202	1.1
$J_{\text{oc}}$	71	151	2.1	—	—	—
$\Phi_{\text{cx}}$	17	33	1.9	182	464	2.5
$J_{\text{cm}}$	6.6	12	1.9	61	149	2.4

$\text{SO}_4^{2-}$  and  $\text{O}_2$  uptake resulted 0.3–0.7 in the case of  $\text{CN}^-$  and 0.7–1.1 in the case of SHAM inhibition, in accordance with the lower ATP yield of the  $\text{CN}^-$  resistant respiration (Table 1).

Coming now to the effect of short  $\text{SO}_4^{2-}$  deprivation on the energetics of  $\text{SO}_4^{2-}$  transport, it is known that  $\text{SO}_4^{2-}$  deprived plants show an up to five times increase of influx after restoration of the  $\text{SO}_4^{2-}$  content in the nutrient medium<sup>4,7</sup>. This strong response of the uptake capacity could be related to the synthesis of new carrier-proteins, by analogy with the induction of enzyme activities. However transport after deprivation approximates the condition of minimum gradient of chemical potential. Therefore the post-deprivation sulfate influx can be considered net influx and requires energy only to overcome the electrical transmembrane potential. The results of flux analysis (Table 2) carried out at  $25^\circ$  and  $15^\circ\text{C}$  showed temperature coefficients ( $Q_{10}$ ) 1.6–2.1 for  $\text{SO}_4^{2-}$  uptake, translocation and assimilation in condition of steady state supply of sulfate. During recovery from deprivation the

strongly enhanced influx showed  $Q_{10} = 1.1$ , typical of passive diffusion. This behaviour gives support to a mechanism of modulation of the energy coupling for sulfate transport in response to the previous availability of sulfate.

## References

1. Cram, J. 1983. *Plant Physiol.* 72: 204-211.
2. Jullien, M.M. 1973. *Compt. Rendus Acad. Science Paris* 276: 733-736.
3. Lin, W. 1984. *Plant Physiol.* 74: 219-222.
4. Clarkson, D.T. and Smith, F.W., Vanden Berg, P.J. 1983. *J. Exp. Bot.* 34: 1463-83.
5. Hoagland, D.R. and Arnon, D.I. 1950. *Calif. Agr. Exp. Station Circ.* 347.
6. Saccomani, S. and Ferrari, G. 1989. *Maydica* 34: 171-177.
7. Smith, I.K. 1975. *Plant Physiol.* 55: 303-307.

# EFFECT OF GLUTATHIONE ON PHYTOCHELATIN SYNTHESIS AND CADMIUM TOLERANCE IN TOMATO CELLS

P.B. Goldsbrough, M.L. Mendum and S.C. Gupta  
*Department of Horticulture, Purdue University, West Lafayette, Indiana 47907, U.S.A.*

*Plants that are exposed to cadmium accumulate phytochelatins (PCs, poly[ $\gamma$ -glutamylcysteinyl]glycines), peptides that bind cadmium. Synthesis of PCs is prevented by buthionine sulfoximine (BSO) resulting in greatly reduced tolerance to cadmium. In the presence of BSO, GSH restores both PC synthesis and cadmium tolerance in tomato cells. In the absence of BSO, exogenous GSH stimulates production of PCs. Increase in total PC content under these conditions is largely the result of elevated levels of PC<sub>2</sub> and, to a lesser extent, PC<sub>3</sub>. These results provide further insight into the mechanism of PC synthesis in plants.*

Cadmium is toxic to all organisms and adversely affects a large number of biochemical processes<sup>1</sup>. In order to preserve metabolic activity under these conditions, mechanisms have evolved that provide a general protection against cadmium. In animals this involves the production of metallothioneins<sup>2</sup> (MTs), proteins that chelate cadmium and other heavy metals. The fission yeast, *Schizosaccharomyces pombe*, and many, if not all, plant species produce phytochelatins<sup>3-6</sup> (PCs, poly[ $\gamma$ -glutamylcysteinyl]glycines). These peptides bind cadmium, and perhaps other metals, in a manner similar to MTs, and have been shown to be essential for normal tolerance to cadmium<sup>4,5</sup>. However, the structure of PCs indicates that, unlike MTs, they are not translation products of mRNA. PCs can be considered as polymers of  $\gamma$ -Glu-Cys on GSH, and a number of studies have indicated that GSH is involved in synthesis of PCs<sup>4,7</sup>. We report here on the effect of exogenous GSH on cadmium tolerance and PC synthesis in tomato cells.

Exposure of plant cells to cadmium results in a rapid decline in cellular GSH levels and a concomitant induction of PC synthesis<sup>4,7</sup>. Production of PCs is inhibited by buthionine sulfoximine<sup>4,5,7</sup> (BSO), a specific inhibitor of  $\gamma$ -Glu-Cys synthetase<sup>8</sup>. We have shown previously that PC synthesis can be at least partially restored in tomato cells treated with BSO by the addition of GSH to the medium<sup>7</sup>. To determine if PC synthesis could be sustained under these conditions, the accumulation of PCs in BSO treated cells supplemented with GSH was monitored over 24 hours (Fig. 1). In the absence of GSH, no PC synthesis was detected in response to cadmium. However, 500  $\mu$ M GSH allowed sustained production of PCs at a rate similar to that observed under normal conditions. In the presence of 50  $\mu$ M GSH, a small amount of PC synthesis was observed. Therefore, the activity that is inhibited by BSO (presumably  $\gamma$ -Glu-Cys synthetase) is not essential for PC synthesis, provided that GSH is available.

It has been shown that BSO decreases tolerance of plant cells to cadmium, demon-

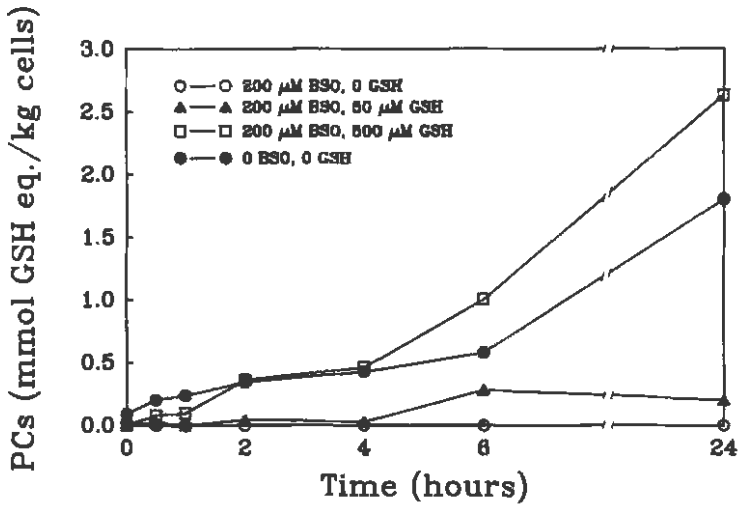

Fig. 1. Inhibition of PC synthesis by BSO and reversal by exogenous GSH. Tomato cells, 4 days after inoculation, were pretreated with 200  $\mu$ M BSO for 16 hours to inhibit GSH synthesis and deplete cellular GSH. Cells were then exposed to 150  $\mu$ M CdCl<sub>2</sub> with the addition of 0, 50 or 500  $\mu$ M GSH. The accumulation of PCs was measured at various times after addition of CdCl<sub>2</sub> and GSH. Control cells (0 BSO, 0 GSH) were treated only with 150  $\mu$ M CdCl<sub>2</sub>. No PC synthesis was observed in cells treated with GSH alone. For PC analysis, 100 mg cells were extracted with 100  $\mu$ l of 10% (w/v) sulfosalicylic acid. After centrifugation, 100  $\mu$ l of the supernatant was analyzed by RP-HPLC, using a 10-20% gradient of acetonitrile in water. The column eluant was derivatized with 75  $\mu$ M DTNB and absorbance measured at 412 nm. Quantitation of PCs is based on peak area of GSH standards.

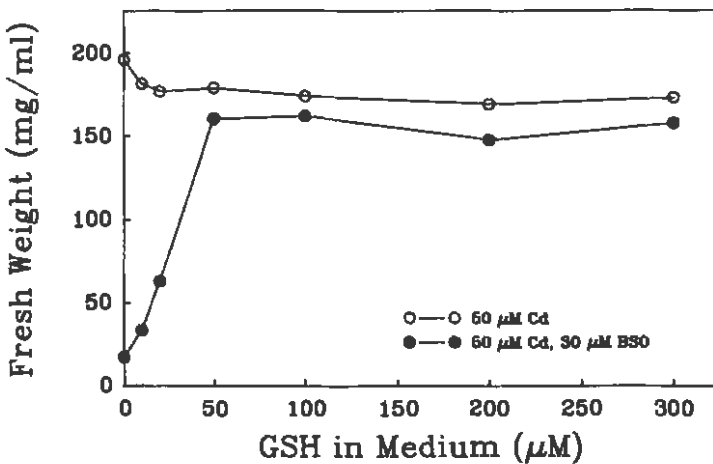

Fig. 2. Effect of BSO and GSH on cell growth in the presence of cadmium. Tomato cells were inoculated at 20 mg FW/ml into media containing either CdCl<sub>2</sub> alone, or CdCl<sub>2</sub> and BSO at the indicated concentrations. The media was supplemented with GSH at concentrations ranging from 0 to 300  $\mu$ M. Growth of cells was measured after 7 days.

strating that binding of cadmium to PCs is an essential component of tolerance to this stress<sup>5</sup>. To determine if exogenous GSH could also restore cadmium tolerance to BSO treated cells, tomato cells were inoculated into media containing cadmium and BSO, supplemented with increasing concentrations of GSH, and growth was measured after 7 days (Fig. 2). In the absence of GSH, the combination of cadmium and BSO prevented growth, as expected. However, 50  $\mu\text{M}$  GSH restored the ability of cells to grow and cells reached a fresh weight similar to that of cells grown in cadmium alone. In the experiment shown in Fig. 1, only a low level of PC synthesis was detected with 50  $\mu\text{M}$  GSH, whereas in the second experiment (Fig. 2) the same concentration of GSH restored cadmium tolerance, presumably as a result of PC synthesis. This difference can be accounted for by the fact that different concentrations of BSO were used, and that the first experiment examined the response to cadmium over 24 hours, while the second measured the effect of GSH during a cell culture cycle of 7 days.

Pretreatment of cells with BSO depletes cellular GSH and prevents PC synthesis<sup>7</sup>. To determine if the supply of GSH limits PC production under normal conditions, tomato cells were exposed to 150  $\mu\text{M}$   $\text{CdCl}_2$  in the presence of 0 to 500  $\mu\text{M}$  GSH, and levels of PCs and GSH were measured at various times after induction of PC synthesis (Fig. 3). In the absence of any GSH in the medium, cellular GSH declined to less than 50% of the initial concentration within 2 hours, and PC synthesis was detected. 50 and 100  $\mu\text{M}$  GSH delayed the decline in GSH until 4 and 6 hours, respectively, after exposure to cadmium. Cells treated with 100  $\mu\text{M}$  GSH showed a two fold increase in PC levels during the first 6 hours when compared to cells treated only with cadmium. 500  $\mu\text{M}$  GSH further increased PC synthesis and cells contained approximately three times the normal PC concentration after 6 hours, demonstrating that the availability of GSH can limit PC production. This concentration of GSH also resulted in a transient increase in cellular GSH levels. It is of interest that after 24 hours the level of GSH in cells was the same, regardless of the media concentration of GSH, indicating that cellular GSH levels are tightly regulated.

The levels of individual PCs were measured in this experiment using HPLC separation and post-column derivatization with Ellman's reagent to specifically detect GSH and PCs<sup>4</sup>. When the amounts of individual PCs were compared between cells treated with 0 and 500  $\mu\text{M}$  GSH, GSH treatment was found to have little effect on the level of  $\text{PC}_4$  (Table 1). However, additional GSH was found to stimulate production of smaller PCs. For example, after exposure to cadmium for 1 hour, the ratio of  $\text{PC}_2$ : $\text{PC}_3$  in control cells was 3:1, and in cells grown in 500  $\mu\text{M}$  GSH was 4:1. Therefore, in addition to increasing the total synthesis of PCs, additional GSH also has a qualitative effect on the spectrum of peptides that are produced in response to cadmium. These results provide insight into the mechanism of PC synthesis. First, availability of GSH is involved in regulating PC production. It is clear that once the initial pool of GSH is utilized in PC synthesis, *de novo* synthesis of GSH is required for sustained production of these peptides. The level of GSH may play a role in regulating the production of PCs. Because these peptides accumulate to millimolar concentrations within cadmium treated cells, PC synthesis must also place a demand on the supply of cysteine, and the uptake and reduction of sulfur. If a single enzyme or com-

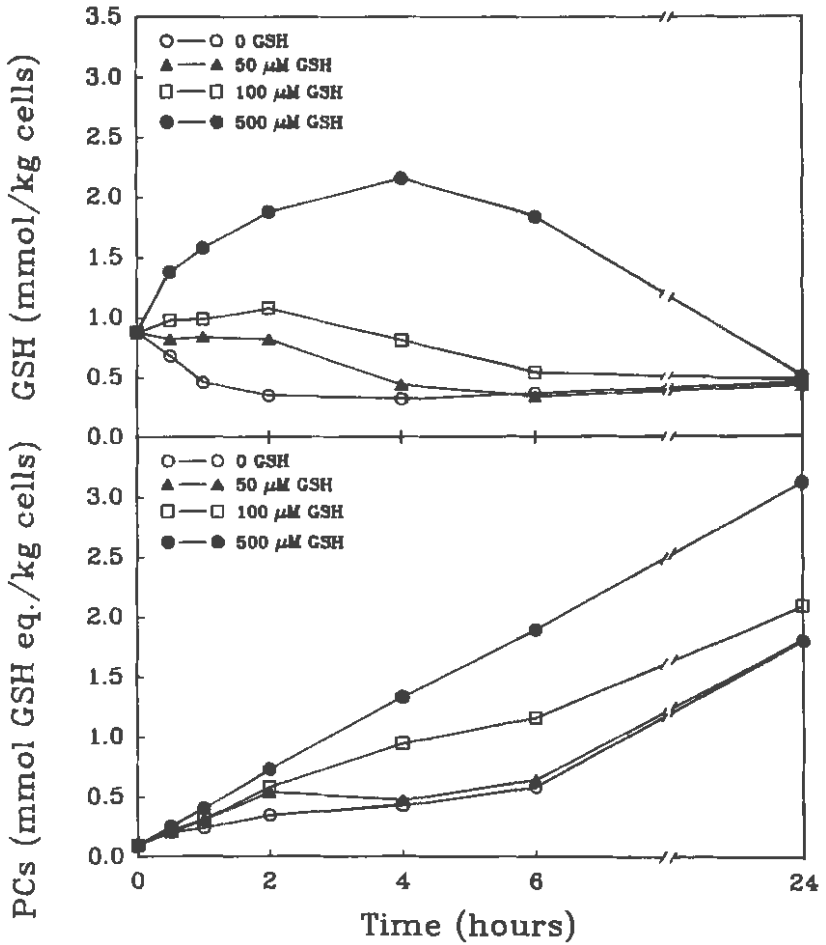

Fig. 3. Stimulation of cadmium induced PC synthesis by exogenous GSH. Tomato cells, 4 days after inoculation, were exposed to  $150 \mu\text{M CdCl}_2$  in the presence of 0, 50, 100 and  $500 \mu\text{M GSH}$  added to the media. Cellular GSH (upper) and total PCs (lower) were measured at various times after addition of cadmium, as described in Fig. 1. PC accumulation was not observed in cells treated with GSH alone.

Table 1. Effect of GSH on synthesis of individual PCs. From the experiment shown in Fig. 3, the levels of  $\text{PC}_2$ ,  $\text{PC}_3$  and  $\text{PC}_4$  were measured in cells exposed to  $150 \mu\text{M CdCl}_2$  in the presence of 0 or  $500 \mu\text{M GSH}$ . PCs are expressed as  $\mu\text{mol GSH equivalents/kg cells}$ .

Time (hrs)	0 $\mu\text{M GSH}$						500 $\mu\text{M GSH}$					
	$\text{PC}_2$	$\text{PC}_3$	$\text{PC}_4$	% Total PC as			$\text{PC}_2$	$\text{PC}_3$	$\text{PC}_4$	% Total PC as		
				$\text{PC}_2$ :	$\text{PC}_3$ :	$\text{PC}_4$				$\text{PC}_2$ :	$\text{PC}_3$ :	$\text{PC}_4$
0	92	-	-	100	0	0	92	-	-	100	0	0
1	178	62	-	74	26	0	320	82	-	80	20	0
6	210	210	160	36	36	27	970	750	172	51	40	9
24	440	1040	320	24	58	18	1110	1660	360	35	53	12

plex is responsible for producing all the PCs, two more conclusions can be drawn from these results. First, this enzyme is not processive in its mode of action; the enzyme does not stay bound to the same PC molecule and continue to add  $\gamma$ -Glu-Cys units. Second, this is a stochastic reaction where substrate availability determines which PCs are synthesized. For example, if GSH and PC<sub>2</sub> are competitors for an active site on the PC synthesis enzyme for addition of another  $\gamma$ -Glu-Cys moiety, the product that is formed will depend on the concentration of competing substrates. Therefore, cells that contain higher concentrations of GSH than PC<sub>2</sub> will produce more PC<sub>2</sub>, as observed in cells grown in the presence of 500  $\mu$ M GSH. Formation of PC<sub>3</sub> will be favored when PC<sub>2</sub> is more abundant than GSH, as seen in control cells where GSH is depleted after the initial synthesis of PCs. These results could be interpreted differently if separate enzymes are responsible for synthesis of each size class of PC. However, we consider this unlikely because the reactions for formation of each PC are so similar.

At least three pathways of synthesis for PC<sub>2</sub> have been suggested as possibilities<sup>9</sup>. These are: transpeptidation of  $\gamma$ -Glu-Cys from GSH to another molecule of GSH; addition of  $\gamma$ -Glu-Cys to GSH; and polymerization of  $\gamma$ -Glu-Cys dipeptides with addition of a carboxy-terminal glycine. Alternatively, sequential addition of Cys and Glu to GSH would also result in production of PC<sub>2</sub>. However, this last mechanism appears unlikely because, in the presence of BSO, GSH and <sup>35</sup>S-Cys, PCs that are synthesized contain little radioactivity (data not shown). What is the source of  $\gamma$ -Glu-Cys units that are required to produce these peptides? Because PC synthesis can occur in the presence of an inhibitor of  $\gamma$ -Glu-Cys synthetase, we favor the hypothesis that  $\gamma$ -Glu-Cys is derived from GSH. Our results, however, are unable to distinguish between the first three proposed pathways. To answer these questions about the mechanism of PC synthesis, it will be necessary to isolate and study the enzymes that are involved. This will provide further insight into the way plants cope with the toxic effects of cadmium, and perhaps other heavy metals, and how this process is regulated.

### Acknowledgements

We thank Deb Altman and Jerry Gaska-Straub for their assistance in preparing this manuscript. This research was supported in part by a Competitive Grant from the United States Department of Agriculture.

### References

1. Valle, B.L. and Ulmer, D.D. 1972. *Annu. Rev. Biochem.* 41: 91-128.
2. Hamer, D.H. 1986. *Annu. Rev. Biochem.* 55: 913-951.
3. Kondo, N., Imai, K., Isobe, M. and Goto, T. 1984. *Tetrahedron Lett.* 25: 3869-3872.
4. Grill, E., Winnacker, E.L. and Zenk, M.H. 1987. *Proc. Natl. Acad. Sci. U.S.A.* 84: 439-443.
5. Steffens, J.C., Hunt, D.F. and Williams, B. 1986. *J. Biol. Chem.* 261: 13879-13882.
6. Jackson, P.J., Unkefer, C.J., Doden, J.A., Walt, K. and Robinson, N.J. 1987. *Proc. Natl. Acad. Sci. U.S.A.* 84: 6619-6623.
7. Scheller, H.V., Huang, B., Hatch, E. and Goldsbrough, P.B. 1987. *Plant Physiol.* 85: 1031-1035.
8. Griffith, O.W. and Meister, A. 1979. *J. Biol. Chem.* 254: 7558-7560.
9. Rennenberg, H. In: *Plant molecular biology*, von Wettstein, D. and Chua, N.-H. eds. pp. 279-292, Plenum.



## THIOL-CONTENT OF PLANTS DEPENDING ON THE ALTITUDE

D. Grill, H. Guttenberger and E. Bermadinger

*Karl-Franzens Universität Graz, Institut für Pflanzenphysiologie, Schubertstrae 51, A-8010 Graz, Austria*

*Water-soluble thiol (SH) content was investigated in Norway spruce needles and in lichens with regard to the altitude and to the season. We found an increase in the water-soluble SH content in spruce needles depending on higher altitude. Spruces (high- or low-altitude provenance) cultivated in different altitudes have a higher thiol-content at 1700 m above sea level (a.s.l.) than at 400 m. Both provenances do not differ in the SH-content significantly. The SH-content seems to depend only on the altitude. At each altitude the thiol-content is higher in winter than in summer – independent of the provenance. Lichens show a similar behaviour at different altitudes, but in lichens taken from altitudes > 1500 m the SH-content is then decreasing again.*

Plants growing at high altitudes are exposed to a variety of stresses that require specific physiological adjustments for survival. Our present study aimed to determine to what extent the SH/SS hypothesis<sup>1,2</sup> applies to evergreen homoiohydric plants (spruces) and poikilohydric plants (lichens) at higher altitudes (*e.g.* forest limit).

We determined the water-soluble thiol (SH) content in spruce needles depending on high- and low-altitude origin in different areas and different altitudes (400 and 1700 m a.s.l. resp.) – see Fig. 1. The SH content of spruce needles of both provenances is higher in trees growing at high altitude. The differences are highly significant ( $P < 0.001$ ) both in summer and in winter (Fig. 1). SH content in winter is higher than in summer ( $P < 0.001$ )<sup>3</sup>. In winter the differences between the two provenances grown at 400 m were only weakly significant<sup>4</sup>. Our results show that spruces grown at forest limits have nearly twice as much water-soluble thiols than trees of the same origin grown at low altitudes. Since the trees are of the same parentage, this difference is not genetically determined, but rather caused by climatic stresses.

We also determined the water-soluble thiol (SH) content in spruce trees and lichens in dependence on the altitude in two profiles. The thiol content in spruce needles is increasing with the altitude (Fig. 2). The poikilohydric lichens also show an increasing thiol content with an increase of the altitude in which they are growing. But lichens show a maximum SH content at 1400 to 1600 m. After this maximum the SH-content is decreasing (Fig. 3). The investigated lichens may have reached their limits of life in these extreme alpine regions and are not longer able to react to the stresses with appropriate physiological reactions – or lichens have developed another methods to survive in these extreme regions.

Plants, both homoiohydric and poikilohydric, react in the sense of Levitt's stress hypothesis<sup>1,2</sup> by rising the thiol content at higher altitudes. Besides, thiols such as glutathione protect plant proteins during frost stress or repair them by restoration

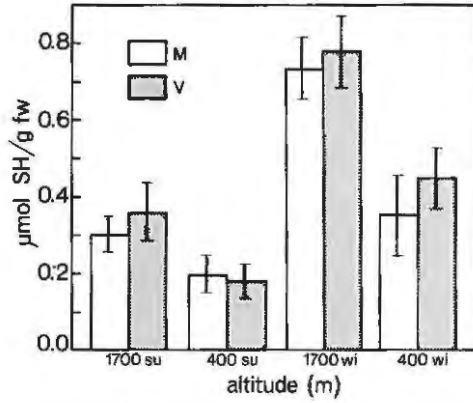

Fig. 1. Content of water-soluble thiols of spruce (*Picea abies* [L.] Karsten) needles from two experimental areas, one at the altitude 1700 m above sea level (a.s.l.) (Stubalpe, Western Styria), the other at 400 m a.s.l. (Tullnerbach, Lower Austria), according to provenance (M = high altitude = 'mountain trees', V = low altitude = 'valley trees'), altitude and season (su = summer, wi = winter); fw = fresh weight. The trees were 10-years-old. Method is based on the reaction of the SH-groups with DTNB (2,2-Dinitro-5,5-dithiodibenzoic acid), the absorbance was measured at 412 nm<sup>3,9</sup>. Bars = standard deviation.

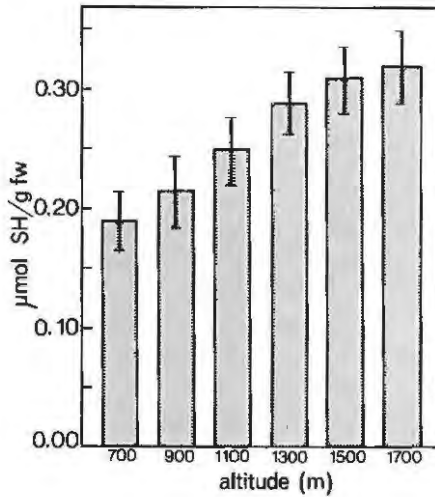

Fig. 2. Needle SH-content of approximately 50-year-old spruces growing along a vertical profile in the Western Styria (Deutschlandsberg) in altitudes from 700 to 1700 m a.s.l. Same method as in Fig. 1.; needles were taken from the upper crown. Bars = standard deviation; fw = fresh weight.

of the SH/SS relation – a very important function in the scavenging of radicals during photooxidative stress<sup>5,6</sup>. Those stresses are typical for stands at higher altitudes as well as the higher light intensities whereby a protecting effect on plant metabolism by thiols can be expected, too<sup>7,8</sup>.

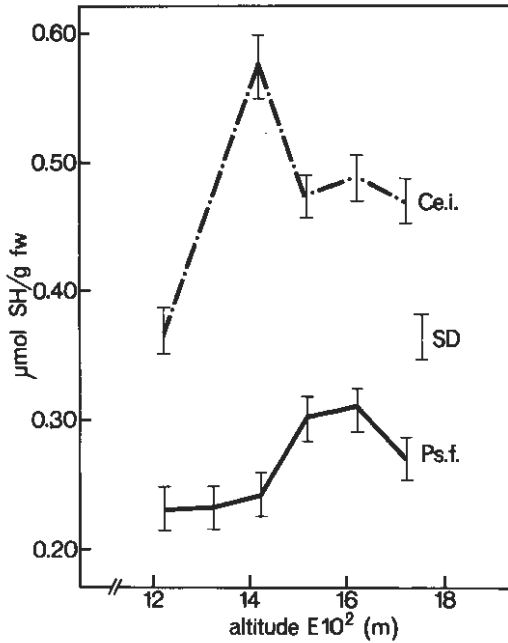

Fig. 3. Total water-soluble SH-group content in lichens (Ce.i. = *Cetraria islandica* (L.) Arch., Ps.f. = *Pseudevernia furfuracea* (L.) Zopf.) collected from 1000 m to 1800 m a.s.l. altitude in the Western Styria (Salzstiegl). Method is based on the reaction of the SH-groups with DTNB (2,2-Dinitro-5,5-dithiodibenzoic acid), the absorbance was measured at 412 nm<sup>10</sup>. SD = standard deviation; fw = fresh weight.

## References

1. Levitt, J. 1956. Academic Press, New York.
2. Levitt, J. 1980. Academic Press, New York.
3. Grill, D. and Esterbauer, H. 1973. *Phyton* (Austria) 15: 87-101.
4. Grill, D., Pfeifhofer, H., Tschulik, A., Hellig, K. and Holzer, K. 1988. *Oecologia* 76: 294-297.
5. Halliwell, B. 1984. Clarendon Press, Oxford.
6. Wise, R.R. and Naylor, A.W. 1987. *Plant Physiol.* 83: 278-282.
7. Rennenberg, H. 1982. *Phytochem.* 21: 2771-2778.
8. Schupp, R. and Rennenberg, H. 1988. *Plant Sci.* 57: 113-117.
9. Grill, D., Esterbauer, H. and Hellig, K. 1982. *Phytopathol. Z.* 104: 264-271.
10. Guttenberger, H., Hainzl, M., Grill, D. and Türk, R. 1989. *Beitr. Biol. Pflanz.* 64: 283-292.

# OZONE EXPOSURE, GLUTATHIONE LEVELS AND PHOTOSYNTHESIS IN HYBRID POPLAR

Ashima Sen Gupta<sup>1</sup>, Ruth Grene Alscher<sup>2</sup> and Delbert C. McCune<sup>1</sup>  
*Boyce Thompson Institute, Ithaca, NY 14853<sup>1</sup> and Virginia Polytechnic Institute and State University, Blacksburg, Va 24061, U.S.A.*

*Ozone inhibited photosynthetic rates in poplars. The inhibition occurred after ninety minutes of ozone exposure. Four hours after ozone exposure photosynthetic rates were still inhibited. The photosynthetic inhibition was non-stomatal in nature. Pyridine nucleotide levels and electron transport were unaffected by ozone. Glutathione levels were elevated in fumigated poplar trees.*

The mechanism through which the oxidizing air pollutant ozone affects apparent photosynthesis is unclear; it is clear, however, that both stomatal and non-stomatal factors are involved. Ozone causes the formation of highly reactive oxyradicals in aqueous solutions<sup>1</sup>. It is quite probable that existing mechanisms for detoxifying oxyradicals are invoked to scavenge the cellular radicals formed by ozone. One such mechanism is the hydrogen peroxide scavenging cycle which operates through a series of oxidations and reductions of the antioxidants glutathione and ascorbic acid and of NADPH<sup>2</sup>. Antioxidant levels have been shown to increase in plants exposed to ozone<sup>3</sup>. Whether the increased antioxidant levels are a measure of adaptation or of damage due to oxidative stress or not, the elevated levels of these compounds represent an energy cost to the plants. We propose that the reduction of photosynthetic carbon assimilation due to ozone is at least partly a result of the diversion of reductant away from photosynthetic carbon assimilation to the increased activity of the superoxide dismutase-ascorbate-glutathione pathway. The results of a first test of this hypothesis are presented here.

## Results

In poplar, photosynthesis declined in trees exposed to ozone (Fig. 1). There was no effect on carbon fixation during the first ninety minutes of ozone exposure. The photosynthetic decline measured was due to non stomatal factors as stomatal resistances were unaffected by ozone. Control and fumigated plants had stomatal resistances of 0.9828 and 0.9891 m<sup>2</sup> s/moles respectively. The electron transport capacity of the chloroplasts was not altered by ozone exposure (250 versus 240 μmoles O<sub>2</sub>/mg chl-h for control versus fumigated samples). The level of glutathione in trees exposed to 180 ppb ozone was higher than that of control trees (Table 1). Both the oxidized (GSSG) and the reduced form of glutathione (GSH) increased in fumigated trees. The ratio of GSH to GSSG, however, shifted from ca. 24 in the control to ca. 2 in fumigated plants. Total glutathione tripled in fumigated samples indicating that there was increased glutathione synthesis in these trees (Table 1).

**Table 1.** Effect of ozone on glutathione levels. Plants were left to equilibrate in a growth chamber for 3 days at saturating light and approximately 65–75% relative humidity. On the fourth day, 4 hours after the lights were turned on the plants were fumigated for 3 hours with 180 ppb ozone. All measurements were made on the fifth emergent leaf or on the first fully expanded leaf 4 hours after the end of fumigation. The results reported are the means of 6 experiments with 5 replicates in each experiment. Glutathione was assayed according to<sup>4</sup>.

	GSH + GSSG ( $\frac{\text{nmoles}}{\text{mg chl}}$ )	GSH ( $\frac{\text{nmoles}}{\text{mg chl}}$ )	GSSG ( $\frac{\text{nmoles}}{\text{mg chl}}$ )	GSH/GSSG
Control	147	141 ± 28	6 ± 2	23.5
Fumigated	437	293 ± 40	144 ± 42	2.0

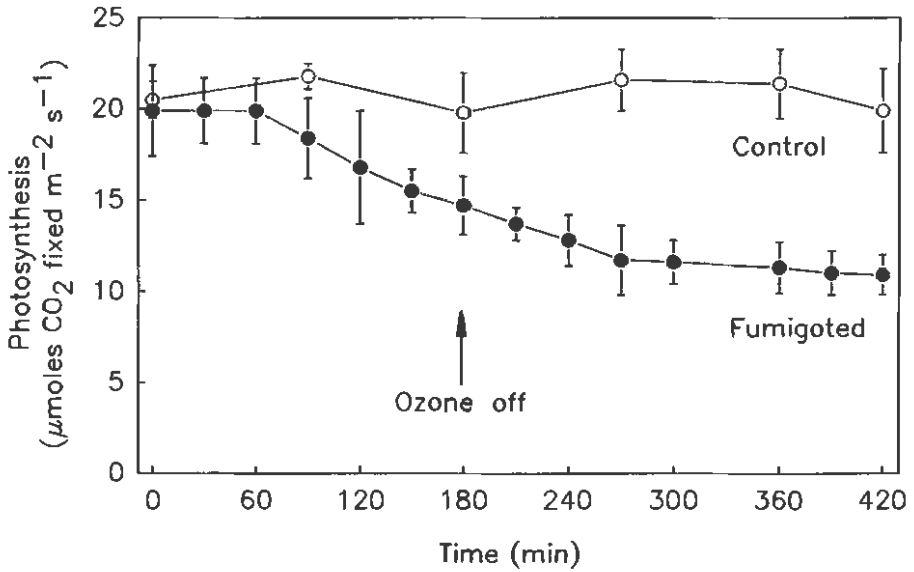

**Fig. 1.** Effect of ozone fumigation on photosynthesis of poplar leaves. See legend for Table 1.

**Table 2.** Effect of ozone on pyridine nucleotides. See legend for Table 1. Measurements were made according to<sup>5</sup>.

	NADPH	NADP	NADPH/NADP	NADH	NAD	NADH/NAD
Control	4.5	3.7	1.2	14.4	9.8	1.5
Fumigated	6.1	4.7	1.3	14.6	10.4	1.4

Both total and reduced glutathione increased in ozone exposed tissues. The consequent increased energy demand for the synthesis and reduction of oxidized glutathione may cause a concomitant reduction in available energy for carbon fixation in fumigated leaves. This may explain part of the decline in photosynthetic car-

bon uptake observed (Fig.1) despite the unchanged pyridine nucleotide levels (Table 2). The relative increase of GSSG is much greater than that of GSH indicating that the rate of oxidation of GSH was greater than the rate of GSH synthesis and the reduction of GSSG.

## References

1. Grimes, H.D., Perkins, K.K. and Boss, W.F. 1983. *Plant Physiol.* 72: 1016-1020.
2. Halliwell, B. and Gutteridge, J.M.C. 1985. In: *Free radicals in biology and medicine*. Clarendon, Oxford.
3. Mehlorn, H., Seufert, G., Schimdt, A. and Kunert, K.J. 1986. *Plant Physiol.* 82: 336-338.
4. Smith, I.K. 1985. *Plant Physiol.* 79: 1044-1047.
5. Matsumura, H. and Miyachi, S. 1980. *Methods Enzymol.* 69: 65-470.

# GLUTATHIONE AND ASCORBATE PARTICIPATE IN HYDROGEN PEROXIDE DEGRADATION IN GERMINATING CASTOR BEAN ENDOSPERM

S. Klapheck, I. Zimmer and H. Cosse

*Botanisches Institut der Universität zu Köln, Gyrhofstr. 15, D-5000 Köln 41, FRG*

*The transformation of fatty acids to sugars in the endosperm of germinating seeds of *Ricinus communis* L. is coupled to the production of  $H_2O_2$  in the glyoxysomes. Although these organelles have high activity of catalase, the results presented in this report provide evidence that in addition to catalase an ascorbate-dependent  $H_2O_2$  scavenging pathway operates in the endosperm. The initial peroxidase of this pathway uses ascorbate as an antioxidant and produces monodehydroascorbate, which may be reduced at the expense of NADH. Alternatively, monodehydroascorbate may be reduced, after nonenzymatic disproportionation to dehydroascorbate, by an enzyme catalysed reaction sequence involving glutathione and NADPH (Fig. 1). The activities of the enzymes participating in this pathway increase significantly during germination. The content of glutathione in the endosperm rises twofold during the first four days of germination, which is in accord with the high activity of glutathione synthetase found in the endosperm. Inhibition of catalase with aminotriazole leads to a 2.5-fold increase of the activity of ascorbate peroxidase and to a 1.4-fold increase of the glutathione content. Since the enzymes of the ascorbate-dependent  $H_2O_2$  scavenging pathway are predominantly localized outside the organelles, this pathway probably functions in  $H_2O_2$  removal in the cytoplasm, whereas catalase is restricted to the glyoxysomes.*

The operation of the ascorbate-dependent  $H_2O_2$  scavenging pathway has been clearly demonstrated in the chloroplasts of spinach<sup>1,2</sup> and pea<sup>3</sup> and functions in removal of  $H_2O_2$  produced during photosynthetic electron transport. Only little attention has been focused on a possible operation of this pathway outside the chloroplasts. The participation of other enzymes besides catalase in  $H_2O_2$  removal in the *Ricinus* endosperm seems reasonable since catalase has a very low affinity to  $H_2O_2$  and is ineffective in destroying  $H_2O_2$  at low concentrations<sup>4</sup>.  $H_2O_2$  can easily permeate membranes<sup>5</sup> and will diffuse from the glyoxysomes to other cellular compartments lacking catalase. Furthermore,  $H_2O_2$  will also be produced outside the glyoxysomes. In mitochondria  $H_2O_2$  is generated by the production of  $O_2^-$  at the electron transfer chain and subsequent dismutation of  $O_2^-$  to  $H_2O_2$  by mitochondrial superoxide dismutase<sup>6</sup>.

First evidence for the significance of the ascorbate-dependent  $H_2O_2$  scavenging system in the *Ricinus* endosperm is given by the increase of the activities of all enzymes participating in this pathway during the course of germination (Fig. 2). Activities of ascorbate peroxidase and monodehydroascorbate reductase are undetectable or low in extracts of dry seeds or in the endosperm of seeds germinated for two days. The activities rise 10- and 7- fold, resp., between day two and four of germination and then decrease rapidly. The dehydroascorbate reductase and glutathione reduc-

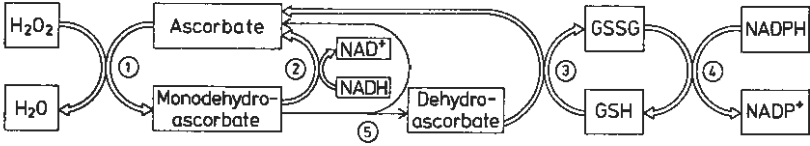

Fig. 1. Ascorbate-dependent  $H_2O_2$  scavenging pathway. (1) ascorbate peroxidase, (2) monodehydroascorbate reductase, (3) dehydroascorbate reductase, (4) glutathione reductase, (5) nonenzymatic disproportionation reaction. GSSG = oxidized glutathione, GSH = reduced glutathione.

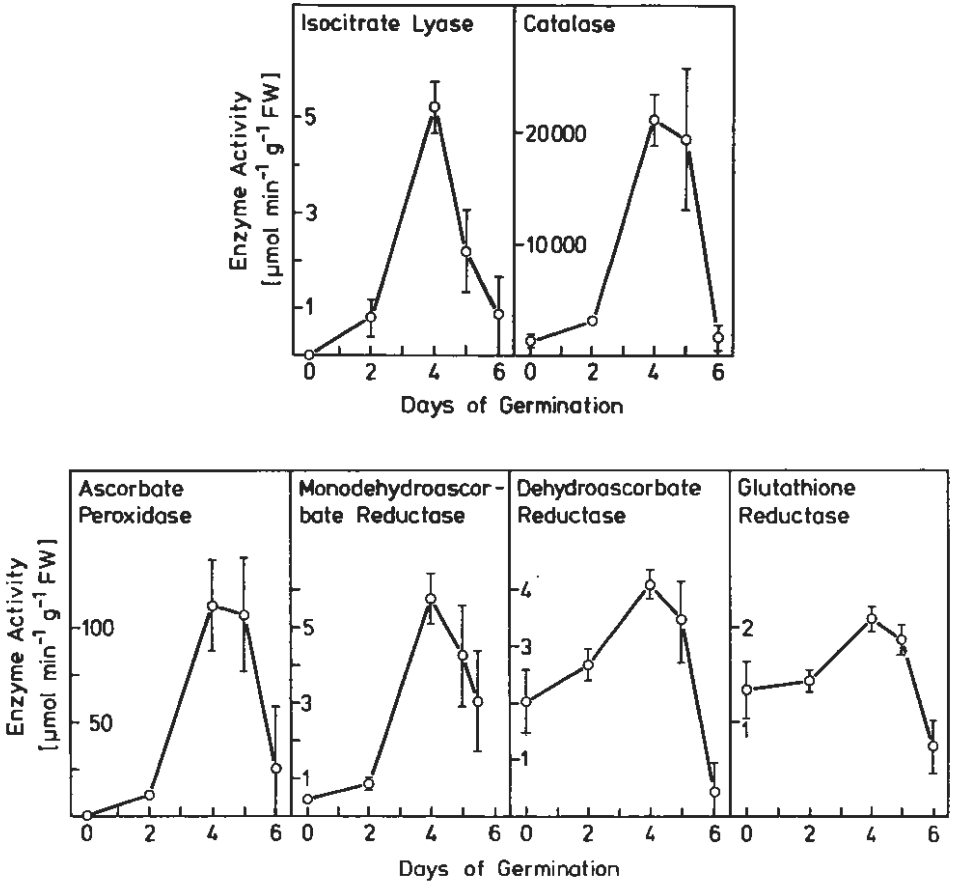
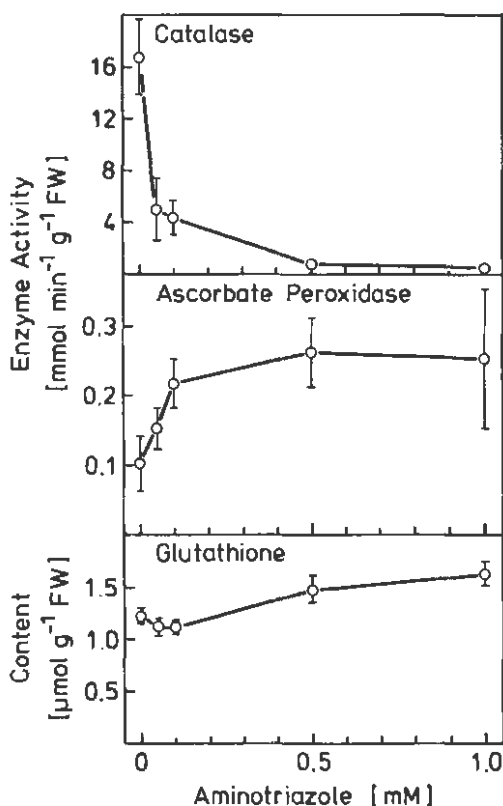

Fig. 2. Developmental changes of the activities of glyoxysomal marker enzymes and of the enzymes of the  $H_2O_2$  scavenging pathway in the endosperm of germinating *Ricinus* seeds. Methods: *Ricinus* seeds were germinated in moist vermiculite at  $30^\circ\text{C}$  for the time indicated. The endosperm of two seeds was homogenized with 10 ml TRIS-HCl 50 mM pH 8.5, 1 mM EDTA, 20 mM  $\text{MgCl}_2$ . The clear supernatant, obtained by centrifugation at  $40,000 \times g$  for 15 min, was used for enzyme assay. Activities of catalase<sup>7</sup>, isocitrate lyase<sup>8</sup>, ascorbate peroxidase and dehydroascorbate reductase<sup>9</sup>, monodehydroascorbate reductase<sup>10</sup> and glutathione reductase<sup>11</sup> were determined photometrically.



**Table 1.** Ascorbate and glutathione content and activity of glutathione synthetase in germinating *Ricinus* endosperm. Methods: Ascorbate was extracted with 6% (w/v) trichloroacetic acid and determined colorimetrically<sup>12</sup>. Glutathione was extracted with 0.1 N HCl and quantified by HPLC-analysis after derivatization with monobromobimane<sup>13</sup>. Glutathione synthetase was extracted as indicated in Fig. 2. Enzyme activity was determined after gel-filtration on Sephadex G-50<sup>14</sup>.

	Days of germination		
	0	2	4
Ascorbate ( $\mu\text{mol g}^{-1}\text{FW}$ )	$0.17 \pm 0.01$	$0.70 \pm 0.14$	$1.05 \pm 0.07$
Glutathione ( $\mu\text{mol g}^{-1}\text{FW}$ )	$0.54 \pm 0.01$	$0.88 \pm 0.20$	$0.98 \pm 0.33$
Activity of glutathione synthetase ( $\text{nmol min}^{-1} \text{g}^{-1}\text{FW}$ )	10.0	$15.3 \pm 2.1$	$11.4 \pm 5.2$



**Fig. 3.** Effect of aminotriazole on the activities of catalase and ascorbate peroxidase and on the glutathione content of *Ricinus* endosperm. Methods: Seeds of *Ricinus* were germinated for four days in the dark at 30°C in vermiculite, moistened with aminotriazole solutions in the concentrations indicated. Enzyme activities were determined in extracts obtained by homogenization of 1 g FW with 9 ml K-phosphate buffer 0.1 M pH 7.0 and centrifugation for 15 min at 40,000 x g as described in Fig. 2. Glutathione content was determined as described in Table 1.

**Table 2.** Distribution of marker enzymes and the enzymes of the  $H_2O_2$  scavenging pathway between the organelle fraction and the cytosolic fraction of a *Ricinus* endosperm homogenate. Methods: The endosperm of *Ricinus communis*, germinated for five days, was chopped with razor blades for 10 min in an isoosmotic grinding medium<sup>15</sup>. The homogenate was filtered through four layers of cheese cloth. The organelle fraction was obtained by centrifugation of 10 ml of the homogenate for 30 min at 10,000 x g and resuspension of the pellet with 2 ml K-phosphate buffer 0.1 M pH 7.0, followed by addition of 8 ml of grinding medium. Enzyme activities were determined in the homogenate, the supernatant (representing the cytosolic fraction) and the organelle fraction. Enzyme activities of the homogenate are set 100%. Activities of fumarase<sup>15</sup>, isocitrate lyase<sup>8</sup>, 6-phosphogluconate dehydrogenase<sup>16</sup> and PEP-carboxykinase<sup>15</sup> were determined photometrically. The enzymes of the  $H_2O_2$  scavenging pathway have been analysed as given in Fig.2. The values given represent mean values  $\pm$ SD of three independent experiments.

	Organelle fraction	Cytosolic fraction
Fumarase (mitochondria)	89 $\pm$ 3 %	3 $\pm$ 4 %
Isocitrate lyase (glyoxysomes)	87 $\pm$ 4 %	15 $\pm$ 3 %
6-phosphogluconate dehydrogenase (plastids and cytoplasm)	31 $\pm$ 6 %	76 $\pm$ 1 %
PEP-carboxykinase (cytoplasm)		110 $\pm$ 16 %
Ascorbate peroxidase	2 $\pm$ 2 %	97 $\pm$ 2 %
Monodehydroascorbate reductase	28 $\pm$ 5 %	76 $\pm$ 4 %
Dehydroascorbate reductase	3 $\pm$ 3 %	102 $\pm$ 1 %
Glutathione reductase	12 $\pm$ 3 %	91 $\pm$ 5 %

tase show a similar time course of the activity with an almost twofold increase compared to ungerminated seeds. The developmental pattern of all enzymes is thus similar to that of isocitrate lyase and catalase, enzymes used as markers for glyoxysomal metabolism indicating the extent of  $H_2O_2$  production (Fig. 2).

The content of ascorbate and glutathione also changes with the time course of germination (Tab. 1). Glutathione is present in high amounts even in ungerminated seeds and increases twofold during germination. In accordance with this increase considerable activity of glutathione synthetase is present (Table 1). The specific activity of this enzyme (1.12 nmol mg<sup>-1</sup> protein min<sup>-1</sup> after 4 days of germination) is almost as high as found for leaf extracts of several plants<sup>14</sup>. Although other seeds also contain high amounts of glutathione<sup>13</sup>, the observed increase in the glutathione content and the high activity of glutathione synthetase indicate that glutathione is essential for the metabolic processes during germination.

Further evidence for the participation of the  $H_2O_2$  scavenging pathway is provided by the experiments shown in Fig. 3. Germination of *Ricinus* seeds with aminotriazole, an irreversible inhibitor of catalase, results in a decrease of catalase activity by 97%. Simultaneously, activity of ascorbate peroxidase increases progressively with increasing aminotriazole concentrations, reaching 2.5-fold higher activities as compared to seeds germinated without inhibitor. Aminotriazole also results in a 1.4-fold increase in the glutathione content of the endosperm.

The  $H_2O_2$  scavenging pathway apparently operates in the cytoplasm. As shown in Table 2, ascorbate peroxidase and dehydroascorbate reductase are only found in the cytosolic fraction of *Ricinus* endosperm, whereas a small part of monodehydroascorbate reductase (28%) and of glutathione reductase (12%) are also bound to organelles.

In order to assess the significance of the  $H_2O_2$  scavenging pathway for the

removal of  $H_2O_2$ , the activity of this system has to be compared to the rate of  $H_2O_2$  production in the endosperm. According to the values given by Gerhardt<sup>17</sup>, the transformation of fat to carbohydrate in the *Ricinus* endosperm leads to the production of  $1.5 \mu\text{mol } H_2O_2 \text{ min}^{-1} \text{g}^{-1}\text{FW}$ . The activities of monodehydroascorbate reductase and glutathione reductase, which catalyse the rate-limiting steps in  $H_2O_2$  removal by the ascorbate-dependent pathway, are  $5.8$  and  $2.1 \mu\text{mol min}^{-1} \text{g}^{-1}\text{FW}$ , resp., and therefore exceed the rate of  $H_2O_2$  production.

The significance of the  $H_2O_2$  scavenging pathway will also depend on the relative activities of catalase and ascorbate peroxidase at in vivo  $H_2O_2$  concentrations. Since catalase has a very low affinity to  $H_2O_2$  ( $K_m$  35-143 mM for catalase isoenzymes from maize<sup>4</sup>), low  $H_2O_2$  concentrations will favour  $H_2O_2$  removal by ascorbate peroxidase, which has a very high affinity to  $H_2O_2$  ( $K_m$  0.03 mM for the spinach enzyme<sup>18</sup>). Probably both, catalase and the ascorbate-dependent  $H_2O_2$  scavenging pathway cooperate in controlling  $H_2O_2$  concentrations at different levels and in different parts of the cell.

## References

1. Foyer, C.H. and Halliwell, B. 1976. *Planta* 133: 21-25.
2. Hossain, M. and Asada, K. 1987. *Ind. J. Biochem. Biophys.* 24: 52-56.
3. Jablonski, P.P. and Anderson, J.W. 1982. *Plant Physiol.* 69: 1407-1413.
4. Scandalios, J.G., Liu, E.H. and Campeau, M.A. 1972. *Arch. Biochem. Biophys.* 153: 695-705.
5. Chance, B., Sies, H. and Boveris, A. 1979. *Physiol. Rev.* 59: 527-605.
6. Puntarulo, S., Sanchez, R.A. and Boveris, A. 1988. *Plant Physiol.* 86: 626-630.
7. Aebi, H. 1984. *Meth. Enzym.* 105: 121-126.
8. Dixon, G.H. and Kornberg, H.L. 1959. *Biochem. J.* 72, 3p.
9. Asada, K. 1984. *Meth. Enzym.* 105: 422-429.
10. Hossain, M.A., Nakano, Y. and Asada, K. 1984. *Plant Cell Physiol.* 25: 385-395.
11. Bielawski, W. and Joy, K.W. 1986. *Phytochem.* 25: 2261-2265.
12. Okamura, M. 1980. *Clin. Chim. Acta* 103: 259-268.
13. Klapheck, S. 1988. *Physiol. Plant.* 74: 727-732.
14. Klapheck, S. and Rennenberg, H. In: *Methods in plant biochemistry*, Brunold, C. ed. Vol. 7 (in press), Academic Press, New York.
15. Cooper, T.G. and Beevers, H. 1969. *J. Biol. Chem.* 244: 3507-3513.
16. Simcox, P.D., Reid, E.E., Canvin, D.T. and Dennis, D.T. 1977. *Plant Physiol.* 59: 1128-1132.
17. Gerhardt, B. 1978. In: *Microbodies/Peroxisomen pflanzlicher Zellen*. p. 62, Springer Verlag Wien New York.
18. Nakano, Y. and Asada, K. 1987. *Plant Cell Physiol.* 28: 131-140.

## BIOSYNTHESIS OF PLANT SULFOLIPIDS

K.F. Kleppinger-Sparace‡, J.B. Mudd†† and S.A. Sparace‡

‡ *The Plant Science Department, Macdonald College of McGill University, Ste. Anne-de-Bellevue, Québec Canada H9X 1C0* and †† *The Plant Cell Research Institute, Inc., 6560 Trinity Court, Dublin, CA 94568, U.S.A.*

*Sulfoquinovosyldiacylglycerol (SQDG) occurs in phototrophic organisms as one of four major glycerolipids. The mechanism of biosynthesis of the headgroup has not yet been elucidated although a sulfoglycolytic sequence was proposed. The results presented here emphasize the importance of DHAP and compounds which stimulate general glycerolipid synthesis in the synthesis of SQDG. Furthermore, these results support the concept that APS or sulfite provide the sulfur moiety during SQDG biosynthesis.*

Chloroplasts are autonomous in the synthesis of the diacylglycerol moiety<sup>1,2</sup> and headgroup, 6-sulfo-6-deoxy- $\alpha$ -D-glucopyranose (SQ)<sup>3-6</sup> of SQDG. UDP-SQ is thought to condense with diacylglycerol to form SQDG, analogous to galactolipid synthesis<sup>7</sup>. Previous studies of <sup>35</sup>SO<sub>4</sub> incorporation into SQDG indicate (1) reduction beyond the level of sulfite is not necessary, (2) that light is required only to provide ATP, and (3) that APS is preferred over PAPS and sulfate<sup>5-7</sup>. These and other results refute involvement of cysteic acid in a sulfoglycolytic sequence<sup>sec 4</sup>. Information is lacking as to which carbon compounds are important for synthesis of the headgroup. Monitoring sulfate incorporation into other chloroform-soluble <sup>35</sup>S-labelled compounds alongside that of SQDG has proven useful in past<sup>4</sup> and current studies in understanding SQDG biosynthesis. Here we report the effects of several sulfur and carbon compounds on synthesis of SQDG and other chloroform-soluble <sup>35</sup>S-labelled compounds (OSL).

In Table 1, only sulfite or the sulfite-generating compounds, bisulfate and thiosulfate, decrease sulfate incorporation into SQDG by over 50%. 0.05 mM Sulfite inhibits SQDG synthesis by 80% but stimulates OSL synthesis. Previously, 0.1 mM sulfite inhibited both SQDG and OSL synthesis by 80%<sup>4</sup>. Biosynthesis of the OSL requires light, greater than 25  $\mu$ M sulfate, and is inhibited by phosphorylated compounds<sup>4</sup>. Joyard *et al.* characterized this fraction as elemental sulfur, migrating at the solvent front in polar lipid solvent systems<sup>2,4,8</sup>. However, the OSL separate into four distinct bands in the solvent system used here, only one of which comigrates with elemental sulfur. Characterization of these compounds is in progress. Thiosulfate inhibits only one OSL while bisulfate, which forms hydrogen peroxide in addition to sulfite, inhibits both SQDG and OSL synthesis. Elemental sulfur and lipoic acid have little effect on SQDG synthesis but penetrate the membrane since OSL synthesis increases upon their addition. Lipoic acid serves as a sulfhydryl donor for thiosulfate reduction among other reactions<sup>9</sup>. Elemental sulfur forms polysulfanes, organic disulfanes and other sulfur compounds<sup>9</sup>. Cysteine and acetylcysteine stimulate SQDG synthesis. These compounds may be acting as a weak thiol since dithiothreitol stimulates sulfate incorporation into SQDG while inhibiting OSL

**Table 1.** Competition studies of  $^{35}\text{SO}_4$  incorporation into SQDG and OSL. Intact chloroplasts from Percoll gradients, equivalent to 100  $\mu\text{g}$  chlorophyll, were incubated in 1 ml media containing 0.33 M Sorbitol, 33 mM BTP/HCl, pH 7.9, 2 mM  $\text{MgCl}_2$ , 2 mM ATP, 100  $\mu\text{M}$   $^{35}\text{SO}_4$  (0.25  $\mu\text{Ci/nmol}$ ) as previously described<sup>5</sup>. Compounds were extracted and analyzed as indicated before<sup>5</sup>, partitioning the chloroform against 1M KCl: 1M acetic acid: 1 M  $\text{Na}_2\text{SO}_4$ . Samples were separated by TLC on silica gel in acetone: acetic acid: water (100:2:1, v/v). Activity is expressed as a percent of the control where the specific activities, in pmol/mg chl·h, were: SQDG = 390 ( $R_f = 0.10$ ),  $X_4 = 205$  ( $R_f = 0.72$ ),  $X_3 = 195$  ( $R_f = 0.83$ ),  $X_2 = 63$  ( $R_f = 0.92$ ),  $X_1 = 29$  ( $R_f = 0.97$ ). Total activity also includes specific activities of other minor compounds.

Compound tested	Total activity pmol/mg chl·h	SQDG % Control	EX	$X_4$	OSL		
					$X_3$ % Control	$X_2$	$X_1$
None	1870	100	100	100	100	100	100
2.0 mM O-Acetylserine	1420	94	52	37	78	16	43
0.1 mM Cysteine	1710	145	60	43	56	53	170
0.1 mM Acetylcysteine	2200	130	110	110	110	92	110
0.1 mM Bisulfate, $\text{S}_2\text{O}_5$	630	9	60	50	64	57	91
0.1 mM Thiosulfate, $\text{S}_2\text{O}_3$	990	20	100	86	100	110	145
0.05 mM Sodium Sulfite	1280	21	140	110	150	180	150
0.1 mM Elemental Sulfur*	1895	82	150	120	170	150	260
0.1 mM Lipoic Acid*	2440	91	240	350	190	150	61
0.1 mM Sodium Molybdate	1580	76	105	74	140	130	59
2.0 mM Sodium Molybdate	770	61	12	12	11	27	0

\* Media plus compound tested were sonicated prior to the addition of chloroplasts.

synthesis<sup>5</sup>. Hydrolysis of acetylcysteine may also occur since acetate stimulates SQDG and OSL synthesis (Table 2). Cysteine and O-acetylserine inhibit OSL synthesis, in agreement with earlier work<sup>4</sup>, suggesting cysteine is a precursor of at least one OSL.

Since molybdate competitively inhibits sulfate activation it was anticipated molybdate would inhibit equally the synthesis of SQDG and the OSL<sup>9</sup>. However, 2 mM molybdate decreases sulfate incorporation into SQDG by 40% while inhibiting OSL synthesis almost completely. In contrast, 0.1 mM molybdate inhibits sulfate incorporation into SQDG and two OSL but increases incorporation into two other OSL.

In Table 2, carbon compounds known to influence glycerolipid synthesis were compared to others which should not affect glycerolipid synthesis to determine their effect on SQDG synthesis. All carbon compounds stimulate SQDG synthesis, with the exception of ascorbate and  $\beta$ -sitosterol which increase synthesis of two OSL. Sulfonation of ascorbate and sterols by PAPS occurs in mammalian systems<sup>9</sup> and sulfonation of flavonoids in plant systems<sup>10</sup> although such compounds do not normally partition into chloroform unless formation of ion pairs is favored<sup>9,11</sup>. Stimulation by ascorbate, rutin, mevalonate and  $\beta$ -sitosterol may be indirect. Differences in oxidation/reduction requirements for synthesis of at least two OSL are reflected in increased labelling of  $X_4$  upon addition of lipoic acid or acetate and increased synthesis of  $X_1$  upon addition of elemental sulfur, ascorbate or bicarbonate. CoA may inhibit synthesis of the OSL in its role as a thiol or detergent upon acylation. Stimulation of SQDG synthesis by DHAP was previously attributed to the generation of ATP and carbon substrates for the sulfoquinovose moiety<sup>6</sup>. Since then the conversion of DHAP to glycerol-3-P inside the chloroplast has been shown<sup>12</sup>. Acetate,

Table 2. Effects of various compounds on  $^{35}\text{SO}_4$  incorporation into SQDG and OSL. Activity is expressed as a percent of the control, where the specific activities, in pmol/mg chl·h, were: SQDG = 570,  $X_4$  = 222,  $X_3$  = 235,  $X_2$  = 62,  $X_1$  = 44. Total activity,  $R_f$  values, and methods are described in Table 1.

Compound tested	Total activity pmol/mg chl·h	SQDG % Control	$\Sigma X$	$X_4$	OSL		
					$X_3$	$X_2$	$X_1$
					% Control		
None	1250	100	100	100	100	100	100
2.0 mM DHAP	2200	370	24	34	24	0	0
2.0 mM Glycerol-3-P	1580	130	100	92	110	120	91
10.0 mM Bicarbonate, Na	2800	290	205	170	210	260	280
0.1 mM Acetate	3600	230	310	320	310	280	210
0.1 mM CoA	1310	220	18	16	18	0	73
0.1 mM Mevalonate	2040	160	150	130	150	220	145
0.1 mM Rutin	2275	180	170	150	170	250	140
0.1 mM $\beta$ -Sitosterol	1580	97	130	110	130	220	170
0.1 mM Ascorbate	1510	98	130	100	140	200	200

\* Media plus compound tested were sonicated prior to the addition of chloroplasts.

bicarbonate, CoA and glycerol-3-P stimulate glycerolipid synthesis by increasing available fatty acid and diacylglycerol.

The data presented here support involvement of APS and sulfite in SQDG synthesis. These results verify carbon compounds which influence general glycerolipid synthesis stimulate SQDG synthesis, including acetate, bicarbonate, CoA and glycerol-3-P. The OSL may represent sulfonation reactions previously unnoticed in chloroplasts in addition to elemental sulfur formation reported by Joyard *et al.*<sup>8</sup>. Stimulation by the carbon compounds suggests limited availability of precursors or necessary cofactors for synthesis of OSL. Synthesis of the OSL is dependent upon the incubation conditions since these are not labelled in intact plants incubated with  $^{35}\text{SO}_4$  *see* 1. The different influence of these sulfur and carbon compounds on synthesis of SQDG versus each OSL suggests a different origin for SQDG, elemental sulfur, and the unknown compound(s). Unequal inhibition of synthesis of SQDG and the OSL by molybdate suggests either that molybdate inhibits sulfate uptake in chloroplasts, inhibits more than one enzymatic reaction or that more than one enzyme exists for sulfate activation, one more sensitive to molybdate than the other.

This work was supported by grant No A2273 from the Natural Sciences and Engineering Research Council of Canada.

## References

1. Bishop, D.G., Sparace, S.A. and Mudd, J.B. 1985. Arch. Biochem. Biophys. 240: 851-858.
2. Joyard, J., Blée, E. and Douce, R. 1986. Biochim. Biophys. Acta 879: 78-87.
3. Haas, R., Sieberts, H.P., Wrage, K. and Heinz, E. 1980. Planta 148: 238-244.
4. Kleppinger-Sparace, K.F., Mudd, J.B. and Bishop, D.G. 1985. Arch. Biochem. Biophys. 240: 859-865.
5. Kleppinger-Sparace, K.F. and Mudd, J.B. 1987. Plant Physiol. 84: 682-687.
6. Kleppinger-Sparace, K.F. and Mudd, J.B. 1987. In: The metabolism, structure and function of plant lipids, pp 309-311, Plenum Press, New York.
7. Kleppinger-Sparace, K.F., Sparace, S.A. and Mudd, J.B. 1989. Plant sulfolipids. In: this volume, pp. 77-88.

8. Joyard, J., Forest, E., Blée, E. and Douce, R. 1988. *Plant Physiol.* 88: 961-964.
9. Roy, A.B. and Trudinger, P.A. 1970. *The biochemistry of inorganic compounds of sulfur*, pp 7-50, 106-317, Cambridge University Press, London.
10. Barron, D., Varin, L., Ibrahim, R.K., Harborne, J.B. and Williams, C.A. 1988. *Phytochem.* 27: 2375-2395.
11. Varin, L., Barron, D. and Ibrahim, R.K. 1987. *Anal. Biochem.* 161: 176-180.
12. Gee, R.W., Byerrum, R.U., Gerber, D.W. and Tolbert, N.E. 1988. *Plant Physiol.* 87: 379-383.

# PROBING FOR PAPS-REDUCTASE IN HIGHER ORGANISMS BY SOUTHERN BLOTTING OF GENOMIC DNA WITH THE CLONED *CYSH* GENE FROM *ESCHERICHIA COLI*

Frank A. Krone, Cornelia Mundt and Jens D. Schwenn  
*Biochemistry of Plants, Ruhr University, 4630 Bochum, Fed. Rep. Germany*

*The PAPS-reductase gene (cysH) from Escherichia coli was used for the detection of a related gene in higher plants through Southern blotting. Heterologous hybridization of the plant genomic DNA with the cysH gene from the bacterium was observed under moderate stringency indicating the occurrence of homologous DNA sequences in tobacco, mustard and rape.*

Higher plants were proposed to reduce sulfate through a set of enzymes which differ from the bacterial reduction mechanism in that carrier-bound sulfite and -sulfide are formed<sup>1</sup>. However, the catalytic properties of the APS-kinase<sup>2</sup>, its regulation by thioredoxin<sup>3</sup> and the participation of thioredoxin in plant sulfate assimilation as reductant in the PAPS-reductase<sup>4</sup> together with the evidence that free anionic sulfite is formed as reaction product of the PAPS-reductase<sup>5</sup> questioned the proposal of a specific plant-type sulfate reducing pathway employing APS-sulfotransferase and thiosulfonate-reductase. If plants in fact possess a set of enzymes which is completely homologous to the sulfate assimilation in bacteria, *i.e.* ATP-sulfurylase, APS-kinase, PAPS-reductase, sulfite-reductase and O-acetylserine sulfhydrylase the relatedness between proteins of different origin would be manifested by homologies in the corresponding DNA. As the current controversy is focussed on the role of the PAPS-reductase, the gene coding for the enzyme was isolated from *Escherichia coli* and employed as genomic probe to determine whether similar DNA sequences exist in phototrophic organisms like plants or cyanobacteria.

## 1. Identification of the *cysH* gene by phenotypic complementation

Before transformation of *E. coli* (JM96, CGSC5746) containing the mutation *cysH56* the strain was made restriction deficient by transducing *hsdR*<sup>-</sup> from a suitable donor strain (LCK8, CGSC6515). A library of wild type DNA from strain K12 was constructed using *Sau3A* restricted fragments of 3-6 kb average size ligated into the *Bam*HI site of pBR322. Transformants of the newly constructed *cysH*<sup>-</sup> *hsdR*<sup>-</sup> strain (JM96RUB) scored as S-autotrophic phenotypes (37 out of 45,000) growing on sulfate. Two out of 12 clones (pCH07 and pCH10, Table 1) contained PAPS-reductase activity exceeding the wild type enzyme activity by a factor of 100 (data not shown). The requirement of the enzyme for thioredoxin was confirmed (Table 2). The PAPS-reductase overproducing plasmids did not complement the cysteine auxotrophic mutants *cysD*, *cysI* or *cysJ*.



Table 1. Specific activity of the PAPS-reductase in the wild type K12 and in complemented auxotrophic transformants of *E. coli* mutant JM 96 (cysH<sup>-</sup>). The enzyme activity was determined as the formation of sulfite from PAPS<sup>4,5</sup>.

Strain / clone	nmole mg min <sup>35</sup> S - SO <sub>3</sub> <sup>2-</sup>
K12 (wildtype)	0.145
pCH01	0.030
pCH02	0.098
pCH03	0.095
pCH04	0.105
pCH05	0.120
pCH06	0.053
pCH07	1.130
pCH08	0.078
pCH09	0.069
pCH10	1.170
pCH11	0.090
pCH12	0.115

Table 2. Requirement of the PAPS-reductase for thioredoxin in the wild type and transformants specific activity of the enzyme determined as before, homogeneous thioredoxin purified from an overproducing strain of *E. coli* SK3981<sup>8</sup>.

Strain / clone	nmole mg min <sup>35</sup> S - SO <sub>3</sub> <sup>2-</sup>
K12 wildtype + Thioredoxin	0.170
K12 wildtype - Thioredoxin	0.018
pCH07 + Thioredoxin	1.870
pCH07 - Thioredoxin	0.021
pCH10 + Thioredoxin	2.050
pCH10 - Thioredoxin	0.020

## 2. Characterization of the cloned cysH DNA

The size of insert in clone pCH10 was 2.9 kb. As evidenced by restriction analysis and DNA sequencing none of the BamHI ligation sites were retained. The insert was cleaved by HincII exclusively (Fig. 1). Restriction with EcoR I and Sal I gave a 3.5 kb fragment containing the cysH DNA enclosed by the two restriction fragments of the plasmid. The complete EcoR I-Sal I fragment was used for the construction of deletion mutants<sup>6</sup> required for DNA sequencing according to Sanger *et al.*<sup>7</sup>. (The DNA sequence of the *E. coli* cysH gene will be published separately).

## 3. Detecting related DNA sequences through hybridization

The EcoR I-Sal I fragment containing the structural gene for PAPS-reductase was used as probe in Southern blots of genomic DNA (10 µg) from *Synechococcus spec.*, *Saccharomyces cerevisiae*, *Nicotiana tabacum*, *Sinapis alba* and *Brassica napus*

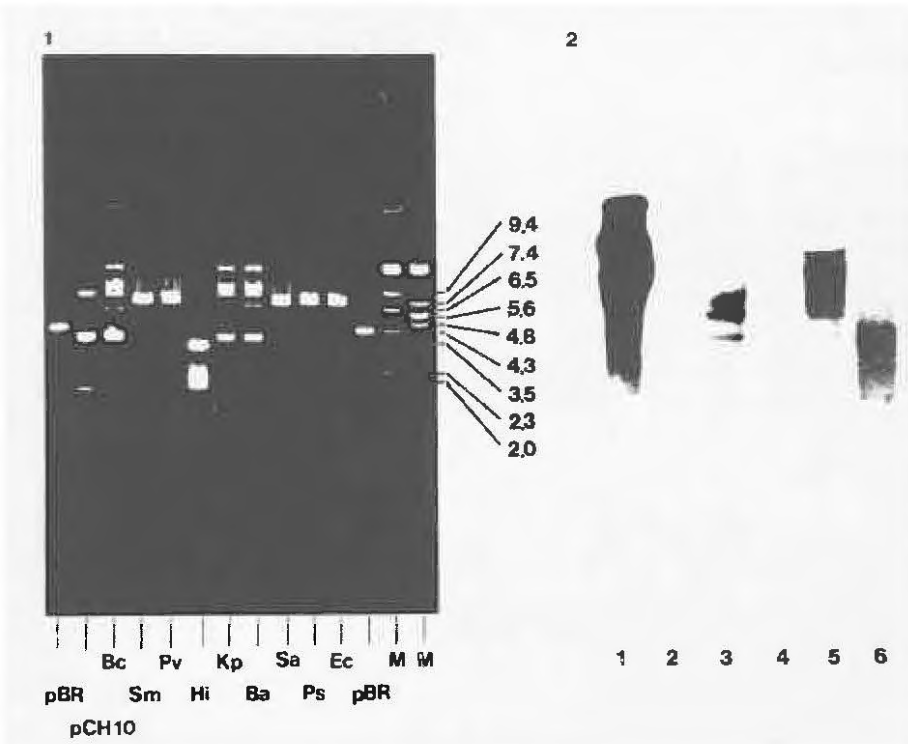

Fig. 1 and 2. Left: 1. Restriction analysis of the clone pCH10 carrying the PAPS-reductase gene from *Escherichia coli*. M - marker: pBR322 digested with EcoRI, size of fragments in kb, pCH10-undigested plasmid, restriction enzymes: Ec - EcoRI, Ps - PstI, Sa - Sall, Ba - BamHI, KpnI, Hi - HindIII, Pv - PvuII, Sm - SmaI, Bc - BclI. Right: 2. Southern blotting of related genes using the PAPS-reductase gene from pCH10 as probe ( $^{32}\text{P}$  labelled by random priming), radio-autograph of the nitrocellulose filter. Genomic DNA 10  $\mu\text{g}$  of the species as listed below were digested with BamHI and separated on 0.8% agarose: 1 - *Escherichia coli*, 2 - control, 3 - *Nicotiana tabacum* L. Var. Samsun, 4 - *Sinapis alba*, 5 - *Saccharomyces cerevisiae*, 6 - *Synechococcus spec.* (thermophile).

(Fig. 2). Heterologous hybridization under conditions of moderate stringency (42°C) were observed with BamHI restricted DNA from tobacco, mustard and yeast. The DNA from the thermophile cyanobacterium and from rape hybridized with lower specificity. Virtually no differences in the hybridization signals were observed between DNA isolated from photoheterotrophically ('green') cell suspension cultures and non-green heterotrophically grown cultures of *N. tabacum*.

The occurrence of a thioredoxin-dependent PAPS-reductase in plants has been reported only recently<sup>4</sup>. This finding is strongly supported by the detection of a DNA sequence from plants which hybridized in Southern blotting of restricted genomic DNA with the cloned probe from *E. coli* coding for the PAPS-reductase (gene *cysH*). As only DNA with a considerable homology hybridizes in a heterologous Southern blot, the structural gene for PAPS-reductase seems highly conserved among the assimilatory sulfate reducers. Moreover, it explains the similarities between the PAPS-reductases investigated from *E. coli*, yeast and plants.

The financial support by the Deutsche Forschungsgemeinschaft is gratefully acknowledged.

### References

1. Brunold, C. 1989. Reduction of sulfate to sulfide. This volume, 13-31.
2. Jender, H.G. and Schwenn, J.D. 1984. Arch. Microbiol. 138: 9-14.
3. Schwenn, J.D. and Schriek, U. 1984. FEBS Lett. 170: 76-80.
4. Schwenn, J.D. 1989. Z. Naturforsch. 44c: 49-53.
5. Schwenn, J.D., Husmann, K. and Krone, F.A. 1988. Arch. Microbiol. 150: 313-319.
6. Henikoff, S. 1984. Gene 28: 351-360.
7. Sanger, F., Nicklen, S. and Coulson, A.R. 1977. Proc. Natl. Acad. Sci. USA 74: 5463-5467.
8. Lunn, C.A., Kathju, S., Kushner, S.R. and Pigiet, V. 1984. J. Biol. Chem. 259: 10469-10474.

## S AND N INTERACTION IN RELATION TO H<sub>2</sub>S EMISSION IN SOME CROP SPECIES

Karuna C. Lakkineni, T.V.R. Nair and Y.P. Abrol

*Division of Plant Physiology, Indian Agricultural Research Institute, New Delhi 110 012, India.*

*Hydrogen sulfide (H<sub>2</sub>S) emission from the leaf discs and crude extracts of mustard, groundnut and wheat leaves, pre-incubated with distilled water, and 5 mM solutions of each sulfate, cysteine, sulfate + nitrate and cysteine + nitrate was investigated using L-(β<sup>35</sup>S) cysteine (5 mM; 18.5 kBq). Pre-incubation with either sulfate or cysteine enhanced H<sub>2</sub>S release, but the increase was inhibited in the presence of nitrate. Activities of cysteine desulphydrase and β-cyanoalanine synthase responsible for the formation of H<sub>2</sub>S from cysteine were detected in all the three species. The reduction of H<sub>2</sub>S emission in the presence of nitrate suggests a strong interaction between S- and N-metabolism.*

Nitrogen and sulfur are both required for the synthesis of S-containing amino acids. Because of the central role of S and N in providing functional integrity to proteins<sup>1</sup>, the requirement of one would depend upon the supply of the other. However, the exact mechanism through which the required concentrations of sulfur and nitrogen at cellular level are maintained, is not clear. Plants may have the capacity to get rid of excess of these nutrients through volatilization from the canopy. Emission of nitrogen as well as sulfur in gaseous form from leaves of higher plants has been reported by Wetselaar and Farquhar<sup>2</sup>, and Rennenberg<sup>3</sup>. Emission of sulfur as hydrogen sulfide from the leaves of higher plants is viewed as a strategy to maintain the endogenous cysteine content at a safer level<sup>3</sup>. The emission is more pronounced when plants are exposed to different sources of excess sulfur<sup>3</sup>. L-/D-cysteine specific desulphydrase, a pyridoxal phosphate dependent enzyme<sup>4</sup>, and cyanide dependent β-cyanoalanine synthetase<sup>5</sup> have been identified to be responsible for the formation of H<sub>2</sub>S from cysteine. The objective of the present study was to investigate whether the H<sub>2</sub>S emission induced by sulfate and cysteine supply can be reduced by a simultaneous provision of nitrogen in the form of nitrate. This is prompted by a suggestion that under N-limited conditions sulfur compounds accumulate as a result of low rates of sulfur influx into protein<sup>3</sup>.

Among the four *Brassica* species studied, the rate of H<sub>2</sub>S emission was highest from the leaf extracts of *B. campestris*, while it was the lowest in the case of *B. carinata*. Pre-incubation of the cut leaves with either sulfate (5 mM) or cysteine (5 mM) enhanced the rates of H<sub>2</sub>S emission in all the *Brassica* spp. studied (Table 1). However, enhancement with the treatment was more severe in *B. campestris* and *B. napus*. Among the three crop species examined (Table 2), wheat leaf discs exhibited highest rates of H<sub>2</sub>S emission. Sulfate and cysteine treatments enhanced the release of H<sub>2</sub>S in mustard and wheat. Simultaneous supply of NO<sub>3</sub><sup>-</sup> either with SO<sub>4</sub><sup>2-</sup> or cysteine resulted in a reduction of H<sub>2</sub>S emission in mustard. In wheat, however, NO<sub>3</sub><sup>-</sup> was effective only when the leaf discs were supplied with SO<sub>4</sub><sup>2-</sup>, but not with cysteine.

*Sulfur Nutrition and Sulfur Assimilation in Higher Plants*

*edited by H. Rennenberg et al., pp. 213–216*

©1990 SPB Academic Publishing bv, The Hague, The Netherlands

**Table 1.** Emission of  $H_2S$  from the leaf extracts of *Brassica* spp. as affected by treatment with sulfate or cysteine. Treated leaves of the above four species were homogenized in phosphate buffer (pH 7.5), containing 5 mM EDTA and 1% PVP. The homogenates were centrifuged at 10,000 g for 15 min. and the supernatants taken in the outer well of the Warburg flask containing  $L-^{35}S$ -cysteine (5 mM; 18.5 kBq.). Inner well contained a trap solution of zinc acetate (100 mM) and sodium acetate (40 mM). After 2h incubation in light ( $800 \mu E m^{-2} s^{-1}$ ) an aliquot of the trap solution was taken for radioactivity measurement and absorbance at 660 nm using Perkin Elmer model-554 spectrophotometer.

Treatment	$H_2S$ emission (nmol $g^{-1}$ f.w. $h^{-1}$ )			
	<i>B. campestris</i>	<i>B. carinata</i>	<i>B. napus</i>	<i>B. juncea</i>
Control ( $H_2O$ )	0.554	0.224	0.493	0.400
Sulfate (5 mM)	0.837	0.300	0.910	0.576
Cysteine (5 mM)	1.010	0.296	0.939	0.554

(Each value is a mean of 2 replicates)

**Table 2.** Effect of sulfate, cysteine and nitrate on the emission of  $H_2S$  from the leaf discs of mustard, groundnut and wheat. Leaf discs obtained from the treated leaves, were floated on Tris buffer (pH 8.0) in the outer well of the Warburg flasks. Inner well contained zinc acetate trap and the  $H_2S$  trapped was measured as described above.

Treatment	$H_2S$ emission (nmol $g^{-1}$ f.w. $h^{-1}$ )		
	Mustard ( <i>B. campestris</i> )	Wheat (HD 2204)	Groundnut (JL-24)
Control ( $H_2O$ )	0.801	1.265	0.254
Sulfate (5 mM)	1.151	1.852	
Cysteine (5 mM)	1.108	2.187	0.804
Sulfate + Nitrate (5 mM)	0.814	1.288	-
Cysteine + Nitrate (5 mM)	0.722	2.634	-

(Each value is a mean of 2 replicates)

**Table 3.** Effect of sulfate, cysteine and nitrate on the emission of  $H_2S$  from the leaf extracts of mustard and groundnut (Method as in Table 1).

Treatment	$H_2S$ emission (nmol $g^{-1}$ f.w. $h^{-1}$ )	
	<i>B. carinata</i>	Groundnut
Control ( $H_2O$ )	0.224	0.149
Sulfate (5 mM)	0.300	0.243
Cysteine (5 mM)	0.296	0.342
Sulfate + Nitrate (5 mM)	0.243	0.171
Cysteine + Nitrate (5 mM)	0.211	0.206

(Each value is a mean of 2 replicates)

In groundnut, cysteine enhanced  $H_2S$  emission. In a similar experiment with leaf extracts of *B. carinata* and *Arachis hypogaea*, the results indicated that nitrate inhibited the enhanced  $H_2S$  release caused by either sulfate or cysteine (Table 3).

Cysteine desulphydrase activity significantly increased in the leaves pre-incubated

**Table 4.** Cysteine desulphydrase (CDS) activity in the leaves of *B. juncea* preincubated with different treatment solutions. Cysteine desulphydrase activity was assayed according to Rennenberg<sup>4</sup> in the leaves of *B. juncea* (cv. Pusa bold, 3 wk old) pretreated as above for 3 h under natural light.

Treatment	CDS activity	
	nmol H <sub>2</sub> S g <sup>-1</sup> f.w. min <sup>-1</sup>	% of control
Control (H <sub>2</sub> O)	1.315	100
Sulfate (5 mM)	2.095	160
Cysteine (5 mM)	3.020	230
Sulfate + Nitrate (5 mM)	1.845	140
Cysteine + Nitrate (5 mM)	1.655	126

(Each value is a mean of 2 replicates)

**Table 5.** Cysteine desulphydrase (CDS) and  $\beta$ -cyanoalanine synthase ( $\beta$ -CAS) activity (nmol H<sub>2</sub>S mg protein<sup>-1</sup> min<sup>-1</sup>) in mustard and wheat. Activities of CDS and  $\beta$ -CAS were assayed according to Rennenberg<sup>4</sup>, and Miller and Conn<sup>5</sup>, respectively. Mustard and wheat seedlings were grown for 3 wks. under pot culture conditions.

Crop species	CDS activity	$\beta$ -CAS activity
Mustard (cv. Pusa bold)		
Cotyledonary leaves	3.20 $\pm$ 0.05	11.39 $\pm$ 0.59
First two leaves	1.59 $\pm$ 0.08	3.31 $\pm$ 0.36
Wheat (cv. HD 2204)		
Seedlings (roots excluded)	1.01 $\pm$ 0.02	7.02 $\pm$ 0.43

with L-cysteine (Table 4). Inclusion of nitrate in the pre-incubation medium resulted in a decrease in the enhancement. Cotyledonary leaves of mustard exhibited higher activity of both cysteine desulphydrase and  $\beta$ -cyanoalanine synthetase than the first two leaves (Table 5). In both mustard and wheat, a higher activity of  $\beta$ -cyanoalanine synthetase is accompanied with a lower cysteine desulphydrase activity.

## Conclusions

All the crop species investigated in this study have been found to emit sulfur in the form of H<sub>2</sub>S from the leaf discs and crude extracts. Pre-incubation of cut leaves with SO<sub>4</sub><sup>2-</sup> and cysteine, enhanced the release of H<sub>2</sub>S. This can be attributed to plants' strategy to maintain the sulfur pool at an appropriate concentration by emitting excess S into the atmosphere<sup>6</sup>. Among the crop species examined, wheat exhibited higher rates of H<sub>2</sub>S emission compared to mustard and groundnut. Among the *Brassica* spp., highest rate of H<sub>2</sub>S emission was observed in *B. campestris*, while the lowest rate was determined in *B. carinata*. This difference may be interpreted as a variation in the genetic potential for H<sub>2</sub>S emission. The presence of a number of S- and N-containing volatile components with highest concentration of aliphatic nitriles and isothiocyanates in the leaves of wild and cultivated *B. campestris*<sup>7</sup>, may be responsible for the higher rates of H<sub>2</sub>S emission in this species.

The enhancement in the emission of H<sub>2</sub>S with an external supply of sulfate

(5 mM) and cysteine (5 mM), was inhibited when nitrate (5 mM) was provided concomitantly with either sulfate or cysteine in both mustard and groundnut. Such a phenomenon suggests a strong interaction between S- and N- metabolism in the above mentioned crop species. However, in wheat, H<sub>2</sub>S emission was reduced by NO<sub>3</sub><sup>-</sup>, only when supplied with SO<sub>4</sub><sup>2-</sup> and not with cysteine.

Activities of cysteine desulphydrase and β-cyanoalanine synthetase responsible for the formation of H<sub>2</sub>S from cysteine were detected in leaf extracts of the above species. β-cyanoalanine synthetase may serve to dispose hydrogen cyanide (HCN) in those plants containing cyanogenic glucosides<sup>8</sup> but the physiological significance of this enzyme in plants unknown to have cyanogenic compounds is obscure.

External supply of cysteine to the leaves of *B. juncea* considerably induced cysteine desulphydrase activity. Provision of NO<sub>3</sub><sup>-</sup> in the medium brought down the activity of the enzyme nearly by two-fold. The decline in cysteine desulphydrase activity in the presence of nitrate, may therefore explain the decline in H<sub>2</sub>S release observed in experiments with leaf discs. However, the mechanism by which NO<sub>3</sub><sup>-</sup> when supplied with SO<sub>4</sub><sup>2-</sup> is able to curtail H<sub>2</sub>S emission through leaves is not understood.

It is proposed that nitrogen interferes with the system responsible for H<sub>2</sub>S emission at the level of substrate availability and diverts excess sulfur towards protein synthesis. Further studies, designed to investigate the protein labelling by <sup>35</sup>S-cysteine as influenced by nitrogen supply are needed to substantiate the hypothesis proposed above.

## References

1. Anderson, J.W. 1980. In: The biochemistry of plants, Miflin, B.J. ed. 5: 203-223.
2. Wetselaar, R. and Farquhar, G.D. 1980. *Advan. Agron.* 33: 263-302.
3. Rennenberg, H. 1984. *Annu. Rev. Plant Physiol.* 35: 121-153.
4. Rennenberg, H. 1983. *Phytochemistry*, 22: 1557-1560.
5. Miller, J.M. and Conn, E.E. 1980. *Plant Physiol.* 65: 1199-1202.
6. Rennenberg, H. 1989. In: Biogenic sulfur in the environment, Saltzman, E.S. and Cooper, W.J. eds., ACS Symposium Series 393: 44-57.
7. Hashimoto, S. and Kameoka, H.J. 1985. *Food Sci.* 50: 847-848.
8. Floss, H.G., Hadwiger, L. and Conn, E.E. 1965. *Nature* 208: 1207-1208.

# SELECTED ASPECTS OF GLUTATHIONE CONJUGATION RESEARCH IN HERBICIDE METABOLISM AND SELECTIVITY

Gerald L. Lamoureux<sup>1</sup>, E. Patrick Fuerst<sup>2</sup> and Donald G. Rusness<sup>1</sup>

<sup>1</sup> USDA, ARS Biosciences Research Laboratory, P.O. Box 5674, State University Station, Fargo, ND 58105, U.S.A.; <sup>2</sup> Department of Agronomy, Washington State University, Pullman, WA 99164, U.S.A.

*In soybean, a chloroacetamide herbicide (propachlor) was metabolized to a homogluthione conjugate. The homogluthione conjugate underwent extensive secondary metabolism by the same routes as utilized in other plant species in the metabolism of glutathione (GSH) conjugates<sup>1, 2, 3, 4</sup>. Thus, it appears that homogluthione conjugates are formed and metabolized in soybean in a manner similar to the formation and metabolism of GSH conjugates in other plant species. The selectivity of chloroacetamide herbicides has been attributed to a higher rate of herbicide GSH conjugation in resistant species, but in this study, differences in the toxicity of four chloroacetamide herbicides to resistant corn was primarily related to factors in addition to the rate of GSH conjugation. In addition to the presence of the necessary glutathione S-transferase (GST) isozymes, levels of reduced glutathione could be a factor in the resistance or susceptibility of plant species to preemergence pesticides that are detoxified by GSH conjugation. Levels of reduced glutathione were much lower in susceptible giant foxtail than in resistant corn. The ability of BAS 145 I38 antidote to protect corn from a chloroacetamide herbicide was associated with an increased rate of herbicide metabolism that caused a dramatic reduction in herbicide concentration in the developing leaves. The herbicide synergist, tridiphane, was metabolized to a GSH conjugate in giant foxtail leaves. This conjugate, which is an inhibitor of GST enzymes, remained in the leaves at concentrations sufficient to inhibit glutathione conjugation for up to eight days.*

## Metabolism of a homogluthione conjugate

In soybean leaves, [<sup>14</sup>C-carbonyl]-propachlor was metabolized to a homogluthione conjugate that was subsequently degraded to a cysteine conjugate. Seven metabolites were detected in excised leaves or in the leaves of intact soybean plants grown for 1 hr to 72 days following exposure to <sup>14</sup>C-propachlor. These metabolites, isolated by high performance liquid chromatography (HPLC) and identified by fast atom bombardment mass spectrometry (FAB/MS), included sulfur-linked *N*-malonylcysteine, *N*-malonylcysteine sulfoxide, and 3-sulfinyllactic acid conjugates, and an oxygen-linked *O*-malonylglucoside conjugate<sup>5</sup>. The homogluthione conjugate appeared to be a precursor of the *O*-malonylglucoside. These metabolites from soybean are similar to those produced from GSH conjugates of other chloroacetamide herbicides in other plant species<sup>6</sup>.



Table 1. GSH levels in corn and giant foxtail. GSH was assayed by HPLC (UV, 254 nm) after it had been enzymatically converted to a conjugate of 1-chloro-2,4-dinitrobenzene (CDNB)<sup>11</sup>.

Tissue	nmoles GSH/gram fresh weight	
	Corn (resistant)	Giant foxtail (susceptible)
Dry Seed	380	38
Leaves, 2 cm long	1800	380
Leaves, 5 cm long	600	300
Leaves, 10 cm long	300	300

### Glutathione conjugation and chloroacetamide selectivity

The selectivity of chloroacetamide herbicides has been related to the rate at which different species detoxify these herbicides by GSH conjugation<sup>7</sup>. Therefore, differences in toxicity could be related to the GST enzymes (GST) that catalyze the detoxification reaction and to the levels of reduced glutathione present. Measurements of reduced glutathione levels in the seed and developing leaves of giant foxtail (susceptible) and corn (resistant) suggest that reduced glutathione levels could be a factor in the selectivity of chloroacetamide herbicides between these species (Table 1).

Different chloroacetamide herbicides vary in their toxicity to corn. To determine if differences in toxicity were related to the rates at which these herbicides were metabolized, the toxicities and rates of metabolism of four chloroacetamide herbicides were compared in five corn hybrids: Northrup King hybrid PX 9144 and Great Lakes hybrids GL 313, GL 547, GL 437, and GL 599. The herbicides were known to be metabolized in corn by GSH conjugation<sup>1,4,6,8</sup>. Metabolism rates were determined in coleoptile segments from the five corn hybrids and in intact shoots from PX 9144 corn hybrid. The relative order of toxicity was the same in all five corn hybrids and the relative rates of metabolism in shoots and coleoptiles were very similar. The data obtained with PX 9144 corn hybrid are shown (Table 2). Herbicide uptake was not involved in differences in toxicity. Propachlor was the least toxic herbicide and was metabolized at the highest rate; however, metazachlor was over 10 times more toxic than metolachlor, yet metazachlor and metolachlor were metabolized at similar rates (Table 2). It appears that differences in toxicity must be related to factors in addition to rate of metabolism, *i.e.*, the effect of the herbicides at the target site(s).

### Antidotes

Herbicide antidotes can protect corn and sorghum from injury by some herbicides. It has been proposed that antidotes function with chloroacetamide and thiocarbamate herbicides by causing an elevation in the rate of herbicide detoxification by conjugation with GSH. Although this has been disputed<sup>9</sup>, these studies with BAS 145 138 antidote and metazachlor herbicide (BASF Corp.) support this theory. The antidote, BAS 145 138, reduced metazachlor toxicity to PX 9144 corn hybrid from an  $I_{50}$  of 0.82 ppmw to an  $I_{50}$  of 8.8 ppmw. The  $I_{50}$  values were based on inhibition of

**Table 2.** Comparison of herbicide toxicity to the rate of herbicide metabolism in PX 9144 corn hybrid. Toxicity was evaluated by shoot height 10 days after the seed had been planted in vermiculite and watered with different concentrations of the herbicides. Metabolism rates were determined in excised corn coleoptiles vacuum infiltrated with 10  $\mu$ M solutions of the  $^{14}$ C-herbicides and in shoots of intact 3.5-day-old corn seedlings surface-treated with 1 nmol  $^{14}$ C-herbicide/shoot.

Herbicide	Toxicity ( $I_{25}$ )	nmol metabolized/gram·h	
		Coleoptile	Shoot
Alachlor	38 $\mu$ M	0.098	0.086
Metazachlor	2.5 $\mu$ M	0.064	0.045
Metolachlor	38 $\mu$ M	0.062	0.046
Propachlor	> 100 $\mu$ M	0.330	0.440

shoot height in corn grown in the presence of metazachlor and in the presence or absence of 5 ppmw antidote incorporated into the soil. Developing leaf, coleoptile, and mesocotyl tissues excised from corn grown for 3.5 days in the presence or absence of antidote were evaluated for their ability to metabolize  $^{14}$ C-metazachlor. Metabolism rates, measured for 30 min, were from 1.8 to 2.4 times higher in the antidoted tissues than in the control tissues. The uptake of  $^{14}$ C-metazachlor by corn was not greatly effected by BAS 145 138; however, all of the tissues from corn grown in the presence of BAS 145 138 contained lower levels of  $^{14}$ C-parent herbicide due to an accelerated rate of metazachlor metabolism (Table 3). The greatest reduction in metazachlor concentration occurred in the developing leaves. Both a reduction in the total residue and in parent herbicide was observed in this tissue. Pulse experiments showed that metabolites of metazachlor produced in the coleoptile did not translocate to the developing leaves. It appears that accelerated metabolism in the outer tissues (coleoptile) made less metazachlor available for movement into the developing leaves. Because of the elevated rate of metabolism in the developing leaves, the parent herbicide that reached the leaves was metabolized to a greater extent.

These data are consistent with the theory that an increased rate of herbicide GSH conjugation is involved in the antidoting of corn from injury by chloroacetamide herbicides, and they are also consistent with the results of antidote studies with metolachlor in sorghum<sup>9,10</sup>

### Synergism

Tridiphane is a synergist of the herbicide atrazine. Previously published data have been consistent with the hypothesis that synergism of atrazine toxicity is partially due to inhibition of GSH conjugation of atrazine, a primary mechanism for atrazine detoxification in resistant plant species<sup>11,12,13</sup>. Both tridiphane and a GSH conjugate of tridiphane were implicated in the inhibition of GSH conjugation of atrazine<sup>11</sup>. *In vivo* experiments have now confirmed that atrazine is metabolized by GSH conjugation in giant foxtail. Giant foxtail was treated at the 1.5-leaf stage with 1 kg/ha  $^{14}$ C-atrazine or with 1 kg/ha each of tridiphane and  $^{14}$ C-atrazine. The herbicide and synergist were applied to the leaves in an aqueous solution containing acetone and a surfactant. Metabolites of  $^{14}$ C-atrazine were compared to the GSH conjugate of atrazine by HPLC and TLC. The level of parent atrazine was elevated 2.1

Table 3. Distribution of  $^{14}\text{C}$  in corn treated with  $^{14}\text{C}$ -metazachlor (nmole equivalents/gram tissue).  $^{14}\text{C}$ -Residues were measured 3.5 days after planting in soil that contained  $^{14}\text{C}$ -metazachlor plus or minus 10 ppmw BAS 145 138. Residues were determined by liquid scintillation spectrometry after partitioning and TLC of tissue extracts.

Tissue	Total $^{14}\text{C}$		$^{14}\text{C}$ -metazachlor	
	Control	Antidoted	Control	Antidoted
Coleoptile	63	64	0.40	0.23
Developing leaves	22	7	0.21	0.03
Mesocotyl	16	17	0.29	0.16
Root	47	47	0.31	0.17

times and the level of atrazine GSH conjugate was reduced 2.6 times in giant foxtail exposed to tridiphane and atrazine as compared to giant foxtail exposed only to atrazine. Measurements were made 18.5 h after treatment.  $^{14}\text{C}$ -Tridiphane was metabolized to a GSH conjugate in giant foxtail leaves. This conjugate was isolated by HPLC and identified by FAB/MS. The GSH conjugate of tridiphane ranged in concentration from 8 to 18 nmoles/gram fresh weight of tissue from 5 h to 8 days following treatment of giant foxtail at 1 kg/ha. The GSH conjugate of tridiphane isolated from giant foxtail after 0.2, 1, 2, 3, 4, 6, and 8 days was highly inhibitory to giant foxtail GST assayed with CDNB. An  $I_{50}$  value of 1.4  $\mu\text{M}$  was estimated from Dixon plots of these data. It had been reported previously that the GSH conjugate of tridiphane was inhibitory to a variety of GSH conjugation reactions catalyzed by house fly, pea, corn, giant foxtail, and equine GST<sup>11</sup>. The  $I_{50}$  values ranged from 11  $\mu\text{M}$  for atrazine with corn GST to ca 0.8  $\mu\text{M}$  for CDNB with equine GST. It was concluded that tridiphane is metabolized to a GSH conjugate in giant foxtail and the concentration of that conjugate is sufficient to interfere with GSH conjugation reactions involved in the detoxification of pesticides. Since parent tridiphane may also inhibit some of these GSH conjugation reactions<sup>11</sup>, it is not clear whether tridiphane or the GSH conjugate of tridiphane is more important in the inhibition of these reactions.

Mention of a commercial or proprietary product does not constitute a recommendation for use by the U.S. Department of Agriculture.

## References

1. Lamoureux, G.L. and Rusness, D.G. 1986. In: Xenobiotic conjugation chemistry, ACS Symposium Series 29, Paulson, G.D., Caldwell, J., Hutson, D.H. and Menn, J.J. eds., pp. 62-105, American Chemical Soc., Washington, D.C.
2. Frear, D.S., Swanson, H.R. and Mansager, E.R. 1983. Pestic. Biochem. Physiol. 20: 299-310.
3. Frear, D.S., Swanson, H.R. and Mansager, E.R. 1985. Pestic. Biochem. Physiol. 23: 56-65.
4. Breaux, E.J. 1986. J. Agric. Food Chem. 34: 884-888.
5. Lamoureux, G.L. and Rusness, D.G. 1989. Pestic. Biochem. Physiol. 34: 187-209.
6. Blattmann, P., Gross, D., Kriemler, H.P. and Ramsteiner, K. 1986. The 6th International Congress of Pesticide Chemistry (IUPAC) Ottawa, Canada (Abstract 7A-02).
7. Breaux, E.J. 1987. Weed Science 35: 463-468.
8. Ezra, G., Stephenson, G.R. and Lamoureux, G.L. 1986. The National Meeting of the Weed Science Soc. of America, Houston, Texas, (Abstract 250).

9. Hatzios, K.K. and Hoagland, R.E. (eds.) 1989. Crop safeners for herbicides, Academic Press, New York.
10. Gronwald, J.W., Fuerst, E.P., Eberlein, C.V. and Eglie, M.A. 1987. *Pestic. Biochem. Physiol.* 29: 66-76.
11. Lamoureux, G.L. and Rusness, D.G. 1986. *Pestic. Biochem. Physiol.* 26: 323-342.
12. McCall, P.J., Stafford, L.E., Zorner, P.S. and Gavit, P.D. 1986. *J. Agric. Food Chem.* 34: 235-238.
13. Boydston, R.A. and Slife, F.W. 1986. *Weed Science* 34: 850-858.

## PHYSIOLOGICAL ASPECTS OF Cd-TOLERANCE IN *CHLAMYDOMONAS REINHARDTII*

K. Nagel

*Institut für Biochemie und Lebensmittelchemie der Universität Hamburg, Martin-Luther-King Platz 6, D-2000 Hamburg 13, F.R.G.*

*A comparison of Cd-sensitive and Cd-tolerant cells of the unicellular green alga Chlamydomonas reinhardtii revealed that Cd-tolerance cannot be attributed to an inhibition of Cd-uptake or to an increased synthesis of Cd-binding complexes. As the predominant part of the Cd<sup>2+</sup> incorporated by the cells was found to be associated with the chloroplast fraction, a central role of this cellular compartment in Cd-tolerance mechanisms was postulated. This assumption was supported by findings, that O<sub>2</sub> production in Cd-tolerant cells was hardly affected by moderate Cd<sup>2+</sup> concentrations whereas it was inhibited almost completely in Cd-sensitive cells. Furthermore, striking differences between the effect of Cd<sup>2+</sup> on chlorophyll accumulation, ATP content, acetate uptake and starch synthesis in both cell lines had been found.*

Cadmium is incorporated and accumulated in large amounts by all organisms tested so far<sup>1,2</sup>. Despite of intensive research, the exact molecular mechanisms of Cd-toxicity are not well understood. However, special proteins, so called metallothioneins, are assigned to play a central role in Cd-detoxification mechanisms<sup>3</sup>. Metallothioneins, which were induced by Cd<sup>2+</sup>, some metal ions and some other factors, are small, cytosolic proteins and had been found in many different organisms, but not in plants. In plants, a class of special Cd-binding peptides called phytochelatin<sup>4,5</sup> or metallothioneins class III<sup>3</sup>, are thought to act in a similar way as metallothioneins.

To elucidate the physiological basis of Cd-tolerance in the unicellular green alga *Chlamydomonas reinhardtii*, the effects of Cd<sup>2+</sup> on Cd-sensitive and Cd-tolerant cells were compared. The Cd-tolerant cells – designated as CW15-Cd<sup>r</sup> cells – used for these experiments were isolated from liquid cultures of the cell wall-deficient mutant CW15+<sup>6</sup> after a long term incubation in the presence of increasing Cd-concentrations<sup>7</sup>. Cells were cultured in axenic batch cultures under mixotrophic conditions and synchronized by a 12 hours light-dark cycling<sup>7</sup>.

Incubating algal cells in the presence of Cd<sup>2+</sup>, growth rate and accumulation of chlorophyll were inhibited (Fig. 1). While 50% inhibition of Cd-sensitive CW15 cells was found at 35 μM Cd<sup>2+</sup>, 110 μM Cd<sup>2+</sup> were necessary to inhibit Cd-tolerant CW15-Cd<sup>r</sup> cells to the same degree. CW15 cells died within an incubation period of 72 hours, if more than 70 μM Cd<sup>2+</sup> were present in the medium, whereas CW15-Cd<sup>r</sup> cells were able to survive 300 μM Cd<sup>2+</sup>.

Cd-tolerant CW15-Cd<sup>r</sup> cells had been kept for more than 300 cell cycles in the absence of Cd<sup>2+</sup> without losing their Cd-tolerance. Furthermore, CW15-Cd<sup>r</sup> cells had been kept in the presence of 60 μM Cd<sup>2+</sup> for more than 150 cell cycles without variations in the observed growth parameters and without variations of the degree of Cd-tolerance. CW15 and CW15-Cd<sup>r</sup> cells did not differ in dry weight (63.4 ± 18.3 pg/cell and 62.2 ± 12.7 pg/cell, respectively), but chlorophyll content of

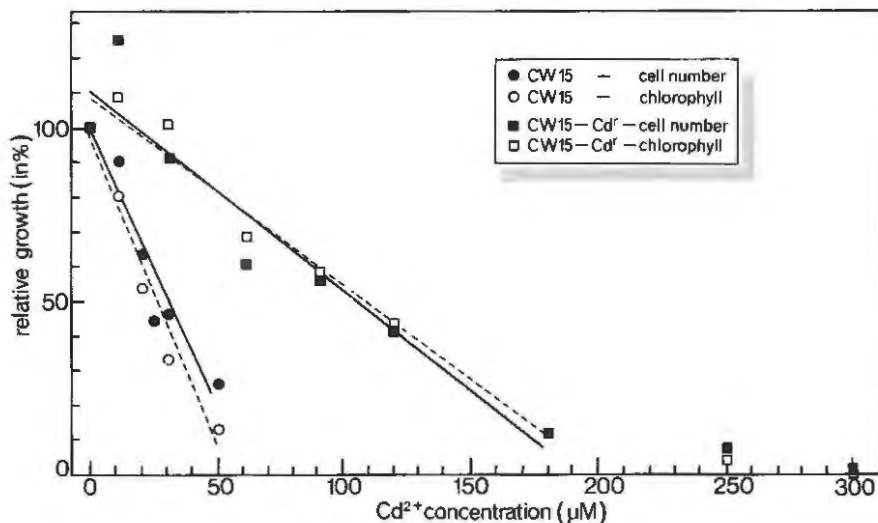

Fig. 1. Effect of increasing concentrations of  $\text{Cd}^{2+}$  on cell concentration and chlorophyll accumulation of CW15 and CW15-Cd<sup>F</sup> cells. Cells of synchronized cultures (12 hours light, 12 hours dark<sup>12, 13</sup>) were incubated in Cd-containing CTM medium<sup>7</sup> for 72 hours. Cell concentration was determined by duplicate haemocytometer counting, chlorophyll was measured according to Arnon<sup>14</sup>. Growth rates of CW15 cells in the absence of  $\text{Cd}^{2+}$  ( $1.47 \pm 0.33$  duplications in 24 hours) were taken as 100%.

CW15-Cd<sup>F</sup> cells was only 60% of the value found in CW15 cells ( $7.2 \pm 1.6$  pg/cell and  $11.9 \pm 2.7$  pg/cell, respectively).

If cells of both lines were incubated in the presence of  $30 \mu\text{M Cd}^{2+}$  (50% growth inhibition of CW15 cells), Cd-uptake during a 12 hours light period of CW15-Cd<sup>F</sup> cells ( $0.14 \text{ nmoles Cd}^{2+} \times \text{h}^{-1}/10^6 \text{ cells}$ ) was found to be about 30% higher than that of CW15 cells ( $0.1 \text{ nmoles Cd}^{2+} \times \text{h}^{-1}/10^6 \text{ cells}$ ), probably because the growth rate of tolerant cells was inhibited only by about 10% at this Cd-concentration. But even in the presence of  $100 \mu\text{M Cd}^{2+}$  (50% growth inhibition of CW15-Cd<sup>F</sup> cells) Cd-uptake in Cd-tolerant cells was at least in the same order of magnitude as that at  $30 \mu\text{M Cd}^{2+}$ . Although the physiological mechanisms of Cd-uptake are not clear, the results clearly show that Cd-tolerance of CW15-Cd<sup>F</sup> cells cannot be attributed to an inhibition of Cd-uptake.

In CW15 and in CW15-Cd<sup>F</sup> cells Cd-binding peptides (CBP) were found after an incubation in Cd-containing medium. The amount of CBP in the cells is directly correlated to Cd-concentration in the medium as well as to the incubation time. CBP isolated from the algal cells showed the same structure as that of the phytochelatin suggested by Grill<sup>8, 9</sup>.

However, Cd-tolerance of CW15-Cd<sup>F</sup> cells was not accompanied by an increase of the amount of CBP in the cytosolic fraction. When cells of both lines were incubated in the presence of  $30 \mu\text{M Cd}^{2+}$ , the amount of  $\text{Cd}^{2+}$  bound in the CBP fraction of Cd-tolerant cells was significantly lower than that of CW15 cells. However, higher amounts of  $^{109}\text{Cd}^{2+}$  were found to be bound by the cytosolic high- and low-MW fractions of Cd-tolerant cells (Fig. 2). As derived from induction kinetics of CBP,

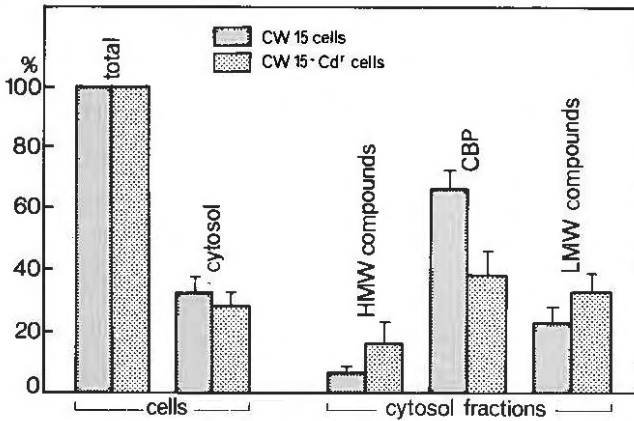

Fig. 2. Relative distribution of Cd<sup>2+</sup> bound to cytosolic compounds of CW15 and CW15-Cd<sup>R</sup> cells. Cells were incubated for 48 hours in the presence of 30 μM Cd<sup>2+</sup> and 0.25 mBq <sup>109</sup>Cd<sup>2+</sup>. CBP were extracted from the cells by the method of Rauser<sup>15</sup> and chromatographed and classified according to Hart and Bertram<sup>16</sup>. Total amounts of Cd<sup>2+</sup> incorporated by 10<sup>9</sup> CW15 or CW15-Cd<sup>R</sup> cells were 1.9 × 10<sup>6</sup> cpm and 2.2 × 10<sup>6</sup> cpm, respectively. For the comparison of size distribution of Cd<sup>2+</sup> in the cytosolic fractions (HMW – high molecular weight; LMW – low molecular weight) total amount of Cd<sup>2+</sup> in the cytosol was taken as 100%.

Cd<sup>2+</sup> was assumed to be bound unspecifically by the compounds naturally occurring in these fractions. It should be mentioned here, that only about 30% of the Cd<sup>2+</sup> incorporated by the algal cells was found in the »cytosolic« fraction obtained by the isolation method of CBP used in these experiments. Compared to 90% of Cd<sup>2+</sup> found in the cytosol of other organisms, this amount is rather low<sup>1</sup>.

A more careful analysis of the distribution of Cd<sup>2+</sup> in the algal cells revealed that more than 50% of the Cd<sup>2+</sup> incorporated was found to be associated with chloroplasts (Fig. 3). Although the yield of intact chloroplasts isolated from CW15 or CW15-Cd<sup>R</sup> cells was very low, about 50% of the cellular Cd<sup>2+</sup> was found in the chloroplast fraction. Only 10% of the Cd<sup>2+</sup> taken up by the cells was localized in the cytosol.

A comparison of some physiological parameters of CW15 cells with that of Cd-tolerant CW15-Cd<sup>R</sup> cells showed many differences. While Cd<sup>2+</sup> strongly inhibited chlorophyll accumulation in CW15 cells, only minor effects were found in CW15-Cd<sup>R</sup> cells<sup>7</sup>. Analogous results were obtained for the O<sub>2</sub> production during the light period (Fig 4). Although CW15-Cd<sup>R</sup> cells liberated lower amounts of O<sub>2</sub>, even concentrations of 60 μM Cd<sup>2+</sup> showed little effects on O<sub>2</sub> production. In Cd-sensitive CW15 cells, 30 μM Cd<sup>2+</sup> inhibited the O<sub>2</sub> production almost completely.

Although Cd-tolerant cells produced rather high amounts of O<sub>2</sub>, ATP concentration in these cells was significantly lower than that found in CW15 cells. At the beginning of the light period, highest ATP concentrations were found in CW15 cells in the absence of Cd<sup>2+</sup> and in CW15-Cd<sup>R</sup> cells in the presence of 100 μM Cd<sup>2+</sup>. At the end of the light cycle, ATP-content of CW15 cells – in the absence as well as in the presence of Cd<sup>2+</sup> – was increased by a factor of 2.3 and 1.8, respectively. In the absence of Cd<sup>2+</sup>, a twofold increase of ATP was also found in CW15-Cd<sup>R</sup> cells, but in

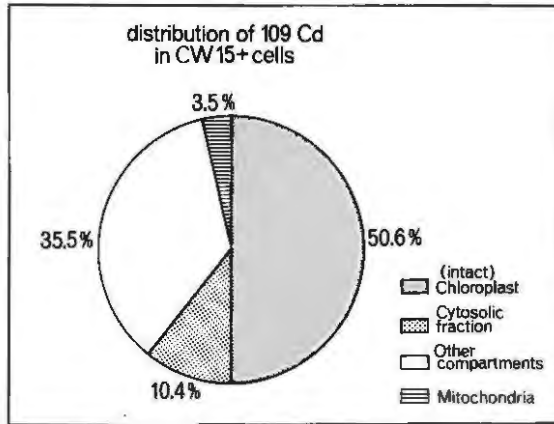

Fig. 3. Distribution of  $\text{Cd}^{2+}$  in cellular compartments of *Chlamydomonas* cells. Isolation of cellular components followed the procedure of Klein<sup>17</sup> with slight modifications. (From U. Adelmeier, Dissertation Universität Hamburg 1988).

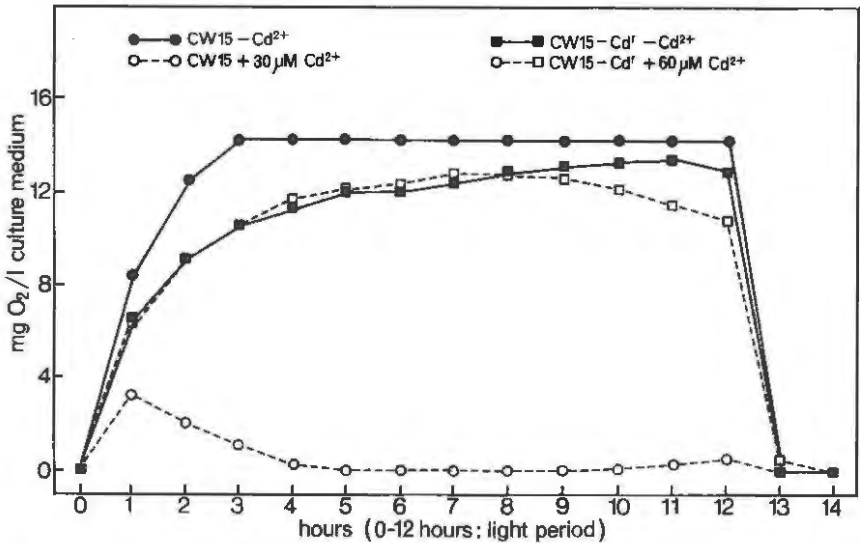

Fig. 4.  $\text{O}_2$  production of CW15 and CW15- $\text{Cd}^+$  cells in the absence and presence of  $\text{Cd}^{2+}$ . Cell concentration was  $2 \times 10^6 \text{ cells} \times \text{ml}^{-1}$  in all cultures.  $\text{O}_2$  production was continuously measured with an  $\text{O}_2$ -electrode in synchronized cultures. Under these conditions, cell concentrations remained constant during the light period and cell division only took place 2 - 4 hours after the beginning of the dark period.

the presence of  $100 \mu\text{M Cd}^{2+}$  a slight decrease in ATP concentration was measured.

Other experiments showed that in the absence of  $\text{Cd}^{2+}$  CW15- $\text{Cd}^+$  cells accumulate higher amounts of starch during the light period than CW15 cells<sup>7</sup>. As cells were grown under mixotrophic conditions in the presence of acetate and as acetate uptake rate of CW15- $\text{Cd}^+$  cells had been found to be higher than that of CW15 cells, it is assumed that acetate from the medium was used for the synthesis of these high amounts of starch.



It is concluded from these results that Cd-tolerance in the algal cells is not due to an increased efficiency of a detoxification system or increased synthesis rate of CBP. As the decreased chlorophyll content of Cd-tolerant cells is believed to be correlated with a reduced rate of photosynthesis and as it has been reported that Cd<sup>2+</sup> has an inhibitory effect on photosystem II in isolated spinach chloroplasts<sup>10,11</sup>, Cd-tolerance in CW15-Cd<sup>r</sup> cells might be mediated by a mutation of a gene coding for a component of the algal photosystem. As Cd-tolerant cells do not differ from Cd-sensitive cells in generation time and dry weight and as they synthesize increased amounts of starch in the presence and absence of Cd<sup>2+</sup>, these tolerant cells must be able to compensate reduced activity of photosystem II, probably by alterations in the metabolic pathways associated with the chloroplast.

## References

1. Webb, M. (ed) 1979. The chemistry, biochemistry and biology of cadmium. Elsevier/North-Holland Biomedical Press, Amsterdam, New York, Oxford.
2. Nath, R. 1986. Environmental pollution of cadmium. Biological, physiological and health effects. Environmental Science Series, Interprint, New Dehli.
3. Kägi, J.H.R. and Kojima, Y. 1987. Metallothionein II. Proceedings of the "second international meeting on metallothionein and other low molecular weight metal-binding proteins". Experientia Suppl. 52.
4. Grill, E., Winnacker, E.-L. and Zenk, M.H. 1985. Science 230: 674–676.
5. Grill, E. and Zenk, M.H. 1985. Naturwissenschaften 72: 432–433.
6. Davies, D.R. and Plaskitt, A. 1971. Genet. Res., Camb. 17: 33–43.
7. Nagel, K. and Voigt, J. 1989. Appl. Environ. Microbiol. 55: 526–528.
8. Grill, E., Winnacker, E.-L. and Zenk, M.H. 1987. Proc. Natl. Acad. Sci. USA 84: 439–443.
9. Gekeler, W., Grill, E., Winnacker, E.-L. and Zenk, M.H. 1988. Arch. Microbiol. 150: 197–202.
10. Li, E.H. and Miles, C.D. 1975. Plant Science Letters 5: 33–40.
11. Van Duijvendijk-Matteoli, M.A. and Desmet, G.M. 1975. Biochim. Biophys. Acta 408: 164–169.
12. Surzycki, S. 1971. Methods Enzymol. 23: 67–73.
13. Voigt, J. and Münzner, P. 1987. Planta 172: 463–472.
14. Arnon, D.I. 1949. Plant Physiol. 24: 1–15.
15. Rauser, W.E. 1987. Experientia Suppl. 52: 301–308.
16. Hart, B.A. and Bertram, P.E. 1980. Environ. Exp. Bot. 20: 175–180.
17. Klein, U., Chen, C., Gibbs, M. and Platt-Aloia, K.A. 1983. Plant Physiol. 72: 481–487.

# DETOXIFICATION OF SULFUR DIOXIDE BY APOPLASTIC PEROXIDASES

Hardy Pfanż, Karl-Josef Dietz, Isa Weinerth and Brigitte Oppmann  
*Lehrstuhl für Botanik II, Universität Würzburg, Mittlerer Dallenbergweg 64,  
D-8700 Würzburg, F.R.G.*

*Soluble and covalently bound peroxidases were isolated from the apoplast of mesophyll cells of leaves. In the crude extract, as well as in partially purified solutions, enzymes capable of oxidizing sulfite to sulfate were present. Oxidation of sulfite could be demonstrated in vitro (with isolated enzymes or isolated cell wall material) and in situ (with detached intact leaves infiltrated with sulfite containing solutions). Furthermore fumigation of leaves with sulfur dioxide increased the amount of extractable soluble peroxidases in the cell wall. Oxidation of sulfur dioxide by apoplastic peroxidases is therefore thought to be a forward defence mechanism in the detoxification of sulfur dioxide, which reduces the flux of SO<sub>2</sub> into the mesophyll cells and thereby decreases the toxic sulfur load of the protoplasts.*

When taken up by plant leaves, SO<sub>2</sub> can be a harmful atmospheric pollutant. Inside the living protoplast it affects various sites (e.g. biomembranes, enzymes etc.)<sup>1</sup> and may lead to intracellular acidification<sup>2</sup>. It is known for a long time that plants are able to detoxify SO<sub>2</sub> in different cell organelles and thereby decrease or even avoid damage. SO<sub>2</sub> can be oxidized to sulfate, or reduced to sulfide in the chloroplasts; S<sup>2-</sup> can then be incorporated into organic matter, or even released into the atmosphere as H<sub>2</sub>S<sup>3</sup>. If detoxification via sulfite oxidation would occur in the aqueous phase of the cell wall surrounding the living protoplast, this could lead to a decreased influx of SO<sub>2</sub> into the protoplasts. We have isolated a soluble and a cell wall bound peroxidase from barley leaves and spruce needles, which both are capable of oxidizing sulfite to sulfate *in vitro* and *in situ*. Fumigation of leaves with SO<sub>2</sub> resulted in an increase in the amount of the soluble cell wall peroxidase.

## Apoplastic protein patterns

Figure 1 shows the protein pattern of the intercellular washing fluid (IWF) of barley leaves. The leaves were kept under 'clean air' conditions (A), or were fumigated with 0.5 ppm SO<sub>2</sub> for 36 h (B). Various soluble cell wall proteins increased in response to the fumigation stress, particularly proteins with a low molecular mass between 20-40 kDa. The peroxidase activity was also increased as shown by an increase in the oxidation rate of guaiacol (data not shown).

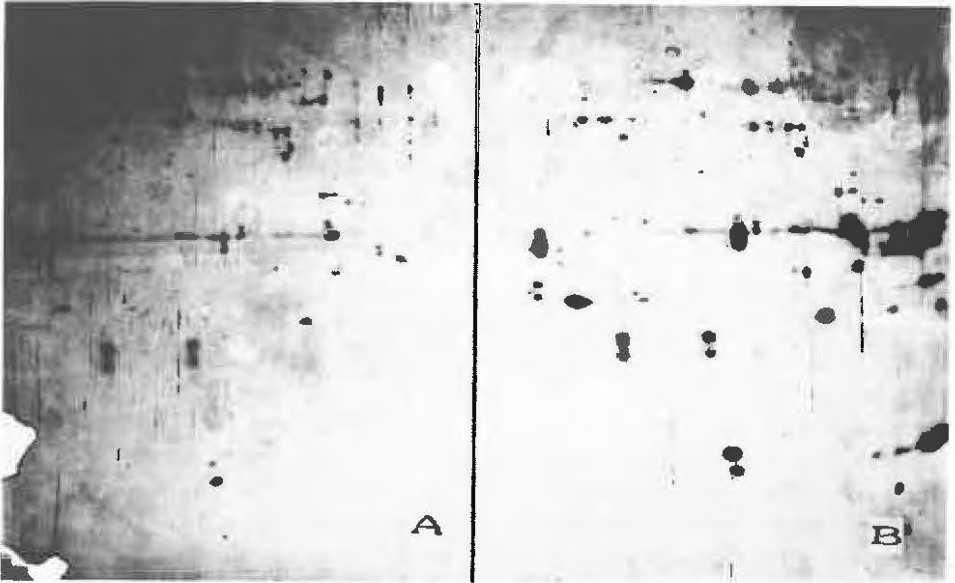

Fig. 1. Silver stained 2D-electropherogram of IWF-polypeptides from 10 d old barley leaves which were either maintained under normal air conditions (A), or were fumigated with 0.5 ppm  $\text{SO}_2$  for 36 h (B). After infiltration of the detached and washed leaves with a solution containing 50 mM Mes pH 6.0, 1 mM  $\text{CaCl}_2$ , and 80 mM sorbitol, the carefully blotted leaves were centrifuged at 800 g for 2 min ( $4^\circ\text{C}$ ). Equal amounts of IWF were applied to the gel. Gels were prepared and run according to Dietz and Bogorad<sup>4</sup>. Contamination of the IWF with cytosolic and chloroplastic constituents was very low ( $< 1.5\%$ ) as determined with hexosemonophosphate-isomerase (predominantly cytosolic marker) and glyceraldehyde-3-P-dehydrogenase (chloroplastic marker) (Pfanz, Dietz and Lang, unpublished data).

### Oxidation of sulfite by isolated soluble cell wall peroxidases

We isolated and partially purified a soluble peroxidase of the IWF of barley. IWF was isolated by infiltrating 10 d old primary leaves of barley with a solution containing 1 mM  $\text{CaCl}_2$ , 4 mM KCl and 80 mM sorbitol. The leaves were then washed with ice-cold bidistilled water, carefully blotted dry and centrifuged at 800 g for 150 s ( $4^\circ\text{C}$ ). The re-extracted solution was collected from the bottom of the centrifugation tube, partially purified using a Sephadex column (PD-10 Sephadex G-25M, Pharmacia, Sweden) and used for the experiments. The method will be described in more detail in a forthcoming paper. The enzyme was capable of oxidizing sulfite<sup>5,6</sup> *in vitro* as shown by the appearance of sulfate in the medium (Fig. 2). Oxidation was not significant when the phenolic compound (phenol or ferulic acid; data not shown) or hydrogen peroxide were omitted (curve I). The reaction was completely inhibited by the addition of catalase ( $0.4 \mu\text{g ml}^{-1}$ ) or 2 mM ascorbate. Superoxide dismutase (SOD,  $8 \mu\text{g ml}^{-1}$ ) did not decrease the oxidation rate, indicating that the superoxide radical ( $\text{O}_2^-$ ) is not directly involved in the reaction. Oxidation rates were  $0.2 \mu\text{mol}$  sulfite oxidized per  $\mu\text{g}$  protein and min. Similar results were obtained when IWF isolated from spruce needles was used.

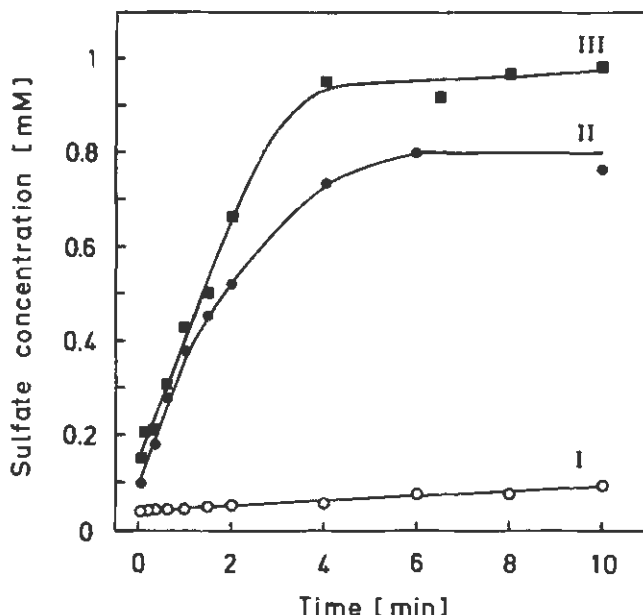
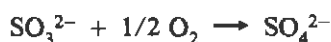

Fig. 2. Sulfite oxidation by an isolated soluble peroxidase. The rate was measured as increase of the sulfate concentration in the medium containing 50 mM Hepes pH 7.5, 50  $\mu$ M ferulic acid,  $H_2O_2$  as indicated below, 2 mM  $Na_2SO_3$  and 2.8  $\mu$ g partially purified soluble cell wall peroxidase. Experiments were carried out at 22°C. At the times indicated, aliquots (100  $\mu$ l) were removed and immediately added to 200  $\mu$ l glacial acetic acid to suppress enzymic oxidation and to shift ionic equilibrium between  $SO_2/HSO_3^-$  and  $SO_3^{2-}$  to the undissociated form. After drying at 100°C, the sediment was dissolved in 500  $\mu$ l  $H_2O$ . Sulfate was determined by ion chromatography (Biotronik, Maintal, FRG). (I) = without  $H_2O_2$ ; (II) = 50  $\mu$ M  $H_2O_2$ ; (III) = 100  $\mu$ M  $H_2O_2$ .

### Oxidation of sulfite by isolated cell wall fragments *in vitro*

Figure 3 shows the oxidation of sulfite by isolated cell wall material as measured by the consumption of oxygen. The overall reaction can be summarized as:



A detailed formulation (via sulfur trioxide  $SO_3$ ) of the radical chain reaction was proposed by Yang<sup>6</sup>. It is shown (Fig. 3) that isolated cell wall fragments are capable of oxidizing sulfite. The oxidation observed is thought to be carried out by peroxidases covalently (or ionically)<sup>7</sup> bound to carbohydrate residues of the cellulose fibres. Sulfite oxidation was inhibited by 85% when 2 mM ascorbate was added to the incubation medium (data not shown).

### Oxidation of sulfite in *in muro* experiments

Leaves were infiltrated with sulfite-containing solutions, and IWF was isolated after various times of incubation. The sulfate concentration increased linearly with time

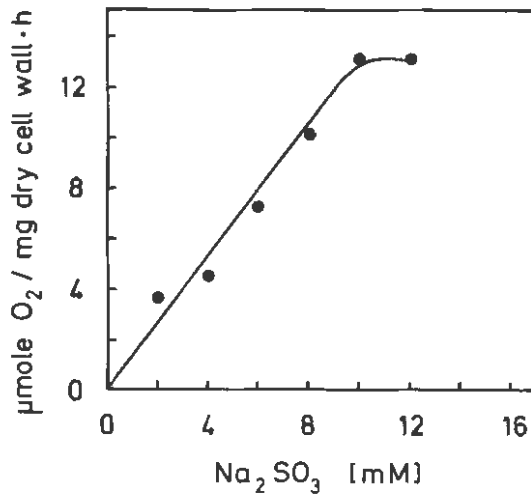

Fig. 3. Rates of oxygen consumption during oxidation of sulfite in the presence of cell wall material ( $400 \mu\text{g ml}^{-1}$ ) isolated from primary leaves of barley. Conditions were similar to those in Fig. 2 except that the concentrations of  $\text{H}_2\text{O}_2$  and ferulic acid were 200 and  $400 \mu\text{M}$ , respectively. Measurements were performed using a Clark type oxygen electrode (Bachofner, Reutlingen, FRG). Cell walls were isolated from carefully homogenized tissue (all steps at  $4^\circ\text{C}$ ). The homogenate was squeezed through nylon gauze ( $100 \mu\text{m}$ ), treated with 0.5% SDS, and repeatedly washed with icecold water. After sonication, the fragments were separated from contaminants by centrifugation at  $700 \text{g}$  ( $4^\circ\text{C}$ ) for 30 min. using a 60% glycerol/water step-gradient. The pellet was washed three times with water and resuspended in buffer (50 mM Hepes pH 7.5, 1 mM  $\text{CaCl}_2$ ) or water. Dry weight was determined with cell wall fragments resuspended in water. Contamination with organelles and lipids was low as determined microscopically and with Sudan III.

(Fig. 4). The appearance of sulfate indicates the oxidation of sulfite by enzymes (presumable peroxidases) located in the cell wall. Sulfite was oxidized despite the fact that neither hydrogen peroxide nor any phenolic substrate was added to the infiltration solution. In experiments with isolated peroxidases or cell wall fragments these substances were prerequisites for sulfite oxidation (Figs. 2 and 3). The reaction was possible because phenolic substances are likely to be present in plant cell walls<sup>8</sup> and hydrogen peroxide is thought to be produced enzymatically in the cell wall<sup>9</sup>. The *in muro* oxidation rates were about  $1.8 \mu\text{mol SO}_3^{2-}$  oxidized (or sulfate formed) per mg Chl and h. This rate is obviously an underestimation, as part of the sulfate produced during sulfite oxidation is taken up by the cells via the plasmalemma during the experimental course (Pfanzen, unpublished results).

The results presented show that in the apoplast of mesophyll cells of leaves soluble and covalently bound peroxidases are present which are capable of oxidizing sulfite to sulfate. Upon  $\text{SO}_2$ -fumigation the activity of the soluble isoform increased due to an increase in the amount of enzyme. Depending on the pH<sup>10</sup>, the buffering capacity<sup>11</sup>, and the pH-stat mechanism in the apoplast, oxidation of sulfuric acid (weak acid) to sulfuric acid (strong acid) could lead to the acidification of the cell wall phase. It remains open to what extent an apoplastic defense mechanism contributes to the overall detoxification of sulfur dioxide in plant cells.

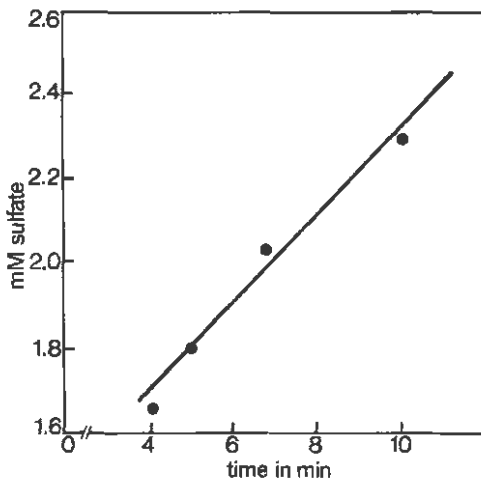

Fig. 4. Sulfite oxidation in the cell wall of intact leaves. Leaves were infiltrated with a solution containing 30 mM Hepes (pH 6.5), 100 mM sorbitol, 1 mM  $\text{CaCl}_2$ , 4 mM KCl, 4 mM  $\text{KHCO}_3$ , and 2 mM  $\text{Na}_2\text{SO}_3$ , and illuminated at  $800 \mu\text{E m}^{-2} \text{s}^{-1}$ . At the times indicated the leaves were centrifuged at 800 g for 2 min ( $4^\circ\text{C}$ ). Aliquots of the IWF were prepared for sulfate determinations as described in Fig. 2. Barley plants grown in normal soil contained 0.5 – 1.5 mM sulfate in the cell wall water; this can account for the fact that up to 2.4 mM sulfate were found in the IWF after 10 min of incubation.

## References

1. Ziegler, I. 1975. *Res. Rev.* 56: 79-105.
2. Pfanz, H., Martinoia, E., Lange, O.L. and Heber, U. 1988. *Plant Physiol.* 85: 928-933.
3. Rennenberg, H., 1984. *Annu. Rev. Plant Physiol.* 35: 121-153.
4. Dietz, K.-J. and Bogorad, L. 1987. *Plant Physiol.* 85: 808-815.
5. Fridovich, I. and Handler, P. 1961. *J. Biol. Chem.* 236 (6): 1836-1840.
6. Yang, S.F. 1970. *Biochem.* 9 (25): 5008-5014.
7. Nessel, A. and Mäder, M. 1977. *Z. Pflanzenphysiol.* 82: 234-246.
8. Higuchi, T. 1981. CRC Press Inc., Boca Raton, Florida 1-19.
9. Gross, G.G., Janse, C. and Elstner, E.F. 1977. *Planta* 136: 271-276.
10. Pfanz, H. and Dietz, K.-J. 1987. *J. Plant Physiol.* 129: 41-48.
11. Pfanz, H., Gsell, W., Martinoia E. and Dietz, K.-J. 1988. *Plant Physiol.* 86: S-899.

# REGULATION OF POLY( $\gamma$ -GLUTAMYL-CYSTEINYL)-GLYCINE SYNTHESIS IN *DATURA INNOXIA* CELL CULTURES

N.J. Robinson, E. Delhaize<sup>1</sup>, W.P. Lindsay, J.M. Berger<sup>2</sup> and P.J. Jackson<sup>2</sup>  
*Department of Biological Sciences, University of Durham, U.K.,* <sup>1</sup>*Division of Plant Industries, C.S.I.R.O., Australia;* <sup>2</sup>*Genetics Group, Los Alamos National Lab., U.S.A.*

*In cell lines of Datura innoxia increased synthesis of poly( $\gamma$ -glutamylcysteinyl)glycine, ( $\gamma$ EC)<sub>n</sub>G, is detected 5 min after exposure to Cd and this response is largely insensitive to cycloheximide. In the absence of exogenous cysteine, glutathione pools are depleted, implying an element of regulation after glutathione synthetase (E.C. 6.3.2.3). However, other data suggests that some de novo glutathione synthesis also occurs. Rates of formation of Cd-( $\gamma$ EC)<sub>n</sub>G aggregates, and total ( $\gamma$ EC)<sub>n</sub>G (apolypeptide plus metal-bound polypeptide), have been examined in Cd-resistant and -sensitive cell lines. Inorganic sulfide is also a component of some Cd-( $\gamma$ EC)<sub>n</sub>G complexes in *D. innoxia*.*

Following exposure to Cd, many plants and plant cell cultures have been shown to synthesize ( $\gamma$ EC)<sub>n</sub>G (where n=2 or greater). These compounds are known by the following names; cadystin, phytochelatin,  $\gamma$ -glutamyl metal-binding peptide and class III metallothionein<sup>1-12</sup>. These polypeptides chelate Cd and Cu within cells thereby reducing the concentration of cytotoxic free metal ions. Metals are coordinated to aggregates of several ( $\gamma$ EC)<sub>n</sub>G molecules<sup>4-6,13</sup>, and the additional presence of inorganic sulfide in some aggregates increases their capacity and affinity for Cd<sup>6,14</sup>. There is a direct correlation between the level of Cd tolerance and maximal accumulation of Cd-( $\gamma$ EC)<sub>n</sub>G aggregates in different Cd-tolerant cell lines of *D. innoxia*<sup>4</sup>. These lines were derived by stepwise selection from a sensitive cell line, WDI, and some of the present studies involve the most resistant of these lines, Cd-300.

( $\gamma$ EC)<sub>n</sub>G consists of a GSH molecule with one or more  $\gamma$ -glutamylcysteine moieties attached. Several independent lines of evidence suggest that GSH is a precursor of ( $\gamma$ EC)<sub>n</sub>G<sup>3,11,15-17</sup>, although cell-free synthesis has not been reported. Accumulation of ( $\gamma$ EC)<sub>n</sub>G has been described in a wide range of taxa but the mechanism of 'Cd-regulation' of ( $\gamma$ EC)<sub>n</sub>G synthesis has not been described.

## Post-translational regulation

Increased synthesis of ( $\gamma$ EC)<sub>n</sub>G from [<sup>35</sup>S]cysteine labelled precursors can be detected 5 min after exposure to Cd in both Cd-300 and WDI (Table 1). Similar rates of synthesis are detected in both cell lines. Subsequent experiments have shown that equivalent amounts of ( $\gamma$ EC)<sub>n</sub>G are accumulated in WDI and Cd-300 for the first

**Table 1.** Synthesis of poly( $\gamma$ -glutamylcysteinyl)glycine, ( $\gamma$ EC)<sub>n</sub>G, in response to Cd in resistant and sensitive cells. Effects of 250  $\mu$ M Cd on the rate of incorporation of L-[<sup>35</sup>S]cysteine into ( $\gamma$ EC)<sub>n</sub>G was determined in Cd-resistant cells, Cd-300, and the sensitive cells from which they were derived, WDI. Cells were exposed to L-[<sup>35</sup>S]cysteine (2.5  $\mu$ Ci ml<sup>-1</sup>) for 2 h prior to exposure to Cd. Extracts were separated by reversed phase HPLC, and radioactivity incorporated into ( $\gamma$ EC)<sub>n</sub>G determined as described previously<sup>9</sup>. The data are expressed as a percentage of the radioactivity incorporated into ( $\gamma$ EC)<sub>n</sub>G in Cd-300 cells after 60 min exposure to Cd.

Time after exposure to Cd (min)	0	5	15	30	60
WDI	9.2	22.7	48.9	64.1	83.8
Cd-300	3.8	17.9	34.1	68.8	100.0

24 h of exposure to 250  $\mu$ M Cd (a level which is lethal to WDI) but that the polypeptides form aggregates with Cd more rapidly in Cd-300<sup>20</sup>. The speed of the induction response implies that the pathway is regulated, at least initially, at a post-translational level. To examine this further, Cd-300 cells were exposed to a concentration of cycloheximide which inhibited the subsequent incorporation of [<sup>3</sup>H]leucine into protein by 99%. Under these conditions, Cd still stimulated incorporation of [<sup>35</sup>S]cysteine into ( $\gamma$ EC)<sub>n</sub>G, with cells exposed to the inhibitor incorporating greater than 50% the amount of radiolabel incorporated in control cells<sup>9</sup>. This induction response has also been shown to be largely insensitive to cycloheximide in tomato cells<sup>11</sup>. Delhaize *et al.*<sup>21</sup> have detected changes in gene expression in WDI and Cd-300 cells following exposure to Cd. However, it is unlikely that 'Cd-induced' genes encode enzymes involved in ( $\gamma$ EC)<sub>n</sub>G biosynthesis since the above data suggest that the pathway is regulated at a post-translational level.

#### Evidence for *de novo* GSH synthesis: Possible feedback regulation by GSH

Coincident with the appearance of [<sup>35</sup>S]cysteine in ( $\gamma$ EC)<sub>n</sub>G there is depletion of radiolabel in GSH, following exposure of Cd-300 cells to a single pulse of [<sup>35</sup>S]cysteine prior to exposure to Cd (Fig. 1). Figure 1 also shows that in Cd-300 cells, as in other species<sup>3, 11, 12, 17</sup>, these responses are inhibited by buthionine sulfoximine, an inhibitor of  $\gamma$ -glutamylcysteine synthetase (E.C. 6.3.2.2). There is also synergism between buthionine sulfoximine and Cd in the inhibition of growth of Cd-300 cells (data not shown).

Depletion of total glutathione (GSH plus GSSG), estimated by a recycling enzymic assay, occurs following exposure to Cd (Fig. 2). The rate of depletion of a pulse of [<sup>35</sup>S]cysteine from the GSH pool is faster than the rate of depletion of total GSH (Fig. 2). This is consistent with either active GSH synthesis after exposure to Cd, or uneven distribution of radiolabel within different GSH pools which are selectively consumed to produce ( $\gamma$ EC)<sub>n</sub>G. However, in the presence of exogenous cysteine (1 mM), the GSH pool is not depleted indicating that *de novo* GSH synthesis occurs but levels of endogenous cysteine may be limiting<sup>18</sup>. *De novo* GSH synthesis might be expected in response to depletion of the GSH pool if  $\gamma$ -glutamylcysteine synthetase



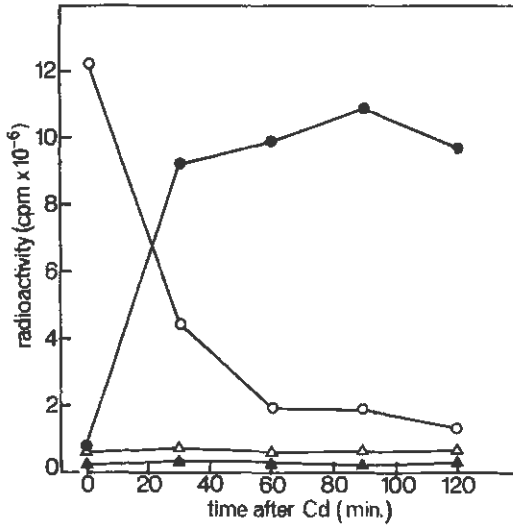

Fig. 1. Synthesis of ( $\gamma$ EC)<sub>n</sub>G and depletion of GSH in response to Cd in the presence and absence of buthionine sulfoximine. Accumulation of [<sup>35</sup>S]cysteine in ( $\gamma$ EC)<sub>n</sub>G (●, ▲), and depletion of [<sup>35</sup>S]cysteine from GSH (○, △) was estimated in Cd-300 cells exposed to 250  $\mu$ M Cd with previous growth in either the presence (▲, △) or absence (●, ○) of buthionine sulfoximine. Cultures were exposed to 2 mM L-buthionine-(S,R)-sulfoximine for 7 h prior to incubation with [<sup>35</sup>S]cysteine for a further 2 h. Cells were then exposed to 250  $\mu$ M Cd for the times indicated, prior to separation of extracts by reversed phase HPLC to determine incorporation of radiolabel into both GSH and ( $\gamma$ EC)<sub>n</sub>G.

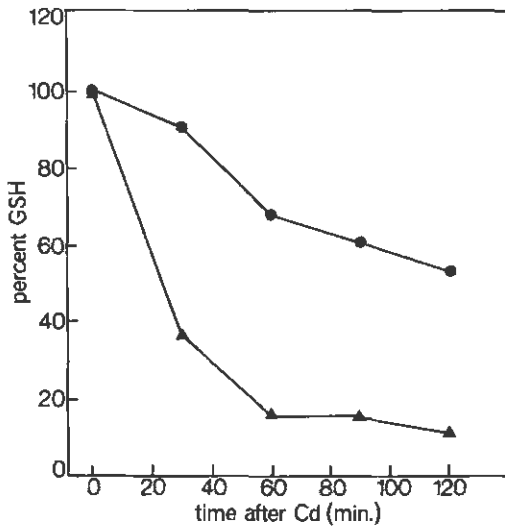

Fig. 2. The effect of Cd on GSH pools in Cd-300 cells. Total GSH content (●) was determined by an enzymic assay, and [<sup>35</sup>S]cysteine content of the GSH pool (▲) was determined following reversed phase HPLC separation of extracts from cells which had been exposed to a single pulse of [<sup>35</sup>S]cysteine for 2 h prior to exposure to 250  $\mu$ M Cd. Values are expressed as a percentage of those obtained prior to addition of Cd.

in *D. innoxia* is subject to non-allosteric feedback inhibition by GSH, as observed for the purified enzyme from rat kidney and homogenates from tobacco cells<sup>19</sup>.

### Evidence for product removal or activation of the final enzyme in the pathway

Depletion of GSH pools in the absence of exogenous cysteine suggests an element of regulation of  $(\gamma\text{EC})_n\text{G}$  synthesis by Cd at some point in the pathway after GSH synthetase (E.C. 6.3.2.3). Putative  $(\gamma\text{EC})_n\text{G}$  synthetase may be activated either directly, or indirectly, by Cd. Alternatively, it has previously been suggested that this response could be mediated by product removal coincident with the production of metal-bound aggregates of  $(\gamma\text{EC})_n\text{G}$ <sup>8</sup>. However, Cd-300 and WDI cells produce equivalent amounts of  $(\gamma\text{EC})_n\text{G}$  (apopolyptide plus metal-bound polypeptide) for the first 24 h after exposure to 250  $\mu\text{M}$  Cd, but formation of Cd-bound aggregates, determined by gel permeation HPLC on SW3000 matrices, is delayed for at least 8 h in WDI<sup>20</sup>. If apopolyptides are initially accumulated in WDI cells it would imply that the pathway is not regulated by product removal coincident with aggregate formation. However, it is also possible that apopolyptides are not initially accumulated in WDI, but that Cd first associates with single  $(\gamma\text{EC})_n\text{G}$  molecules and it is only the process of aggregation of multiple  $(\gamma\text{EC})_n\text{G}$  molecules that is delayed. Other processes which could also cause product removal include, Cd-stimulated oxidation of  $(\gamma\text{EC})_n\text{G}$  with consequent formation of intermolecular disulfide bonds and Cd-stimulated association of  $(\gamma\text{EC})_n\text{G}$  with other molecules such as inorganic sulfide.

### Significance for metal tolerance

Tolerance in Cd-300 does not correlate with increased synthesis of  $(\gamma\text{EC})_n\text{G}$  (Table 1)<sup>20</sup>, implying that there is not modified regulation of  $(\gamma\text{EC})_n\text{G}$  synthesis in response to Cd in Cd-300. However, tolerance in these cells does correlate with rapid formation of Cd- $(\gamma\text{EC})_n\text{G}$  complexes which bind all of the cellular Cd within 24 h<sup>20</sup>. Further experiments are required to describe the chemical composition of the complexes formed in both cell lines in order to identify the basis of rapid complex formation in Cd-300.

Inorganic sulfide is a component of higher molecular weight Cd- $(\gamma\text{EC})_n\text{G}$  complexes in extracts from *D. innoxia* (Fig. 3), as has been reported in *Schizosaccharomyces pombe*<sup>6</sup>. Increased introduction of inorganic sulfide into the complexes in Cd-300 could facilitate production of complexes with a higher binding capacity and/or affinity for Cd as observed in *S. pombe*<sup>6</sup>. In four preliminary experiments, the ratio of inorganic sulfide to Cd, in  $(\gamma\text{EC})_n\text{G}$  complexes separated by gel permeation HPLC, was 2.0, 2.4, 3.2 and 1.7 times higher in extracts from Cd-300 compared to WDI cells, following equivalent exposures to Cd. Steffens *et al.*<sup>12</sup> proposed that  $(\gamma\text{EC})_n\text{G}$  may be a sulfide carrier involved in assimilatory sulfate reduction. Some of the implications of this proposed constitutive function for  $(\gamma\text{EC})_n\text{G}$  have been discussed elsewhere<sup>10</sup>. If  $(\gamma\text{EC})_n\text{G}$  were a sulfur carrier involved in assimilatory sul-

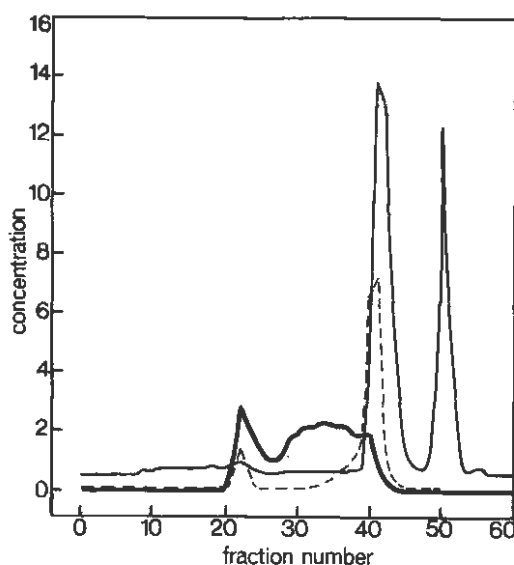

Fig. 3. Association of inorganic sulfide with larger Cd-( $\gamma$ EC) $_n$ G aggregates. An extract from Cd-300 cells exposed to 250  $\mu$ M Cd for 48 h was separated by gel permeation HPLC (on 7.5 x 300 mm column of TSK SW3000) and fractions analysed for Cd ( $\mu$ M) by atomic absorption spectrophotometry (—), total protein ( $\mu$ gml $^{-1}$ ) by Bradford assay (—), and for inorganic sulfide ( $\mu$ M) by the method of King and Morris (---). The cells used for this experiment were diluted with fresh media every 4 days, while those used in previous experiments were diluted every 2 days. The first Cd peak corresponds to Cd-( $\gamma$ EC) $_n$ G while the second peak corresponds to free Cd which has associated with  $\beta$ -mercaptoethanol. Inorganic sulfide is associated with higher molecular weight Cd-( $\gamma$ EC) $_n$ G complexes in Cd-300 cells. Fractions were also analysed for total thiols (data not shown). The inorganic sulfide peaks did not coincide with the total thiol peaks.

fate reduction, then increased activity of ATP sulfurylase (E.C. 2.7.7.4), APS sulfotransferase, or organic thiosulfate reductase (E.C. 1.8.7.1) in Cd-300 could lead to greater saturation of ( $\gamma$ EC) $_n$ G with sulfide.

## References

1. Fowles, B.A., Hilderbrand, C.E., Kojima, Y. and Webb, M. 1987. In: Metallothionein II, Kagi, J.H.R. and Kojima, Y. eds. pp. 19-22, Birkhauser Verlag, Basel.
2. Grill, E., Gekeler, W., Winnaker, E.L. and Zenk, M.H. 1986. FEBS Lett. 205: 47-50.
3. Grill, E., Winnaker, E.L. and Zenk, M.H. 1987. Proc. Natl. Acad. Sci. U.S.A., 84: 439-443.
4. Jackson, P.J., Unkefer, C.J., Doolen, J.A., Watt, K. and Robinson, N.J. 1987. Proc. Natl. Acad. Sci. U.S.A., 84: 6619-6623.
5. Kondo, N., Isobe, M., Imai, K. and Goto, Y. 1985. Agric. Biol. Chem. 49: 71-83.
6. Reese, R.N., Mehra, R.K., Tarbet, E.B. and Winge, D.R. 1988. J. Biol. Chem. 263: 4186-4192.
7. Reese, R.N., and Wagner, G.J. 1987. Biochem. J. 152: 641-647.
8. Robinson, N.J. and Jackson, P.J. 1986. Physiol. Plant. 67: 499-506.
9. Robinson, N.J., Ratliff, R.L., Anderson, P.J., Delhaize, E., Berger, J.M. and Jackson, P.J. 1988. Plant Sci. 56: 197-204.
10. Robinson, N.J. 1989. J. Appl. Phycol. 1: 5-18.
11. Scheller, H.V., Huang, B., Hatch, E. and Goldsborough, P.B. 1987. Plant Physiol. 85: 1031-1035.

12. Steffens, J.C., Hunt, D.F. and Williams, B.G. 1986. *J. Biol. Chem.* 261: 13879-13882.
13. Bernhard, W.R. and Kagi, J.H.R. 1987. In: *Metallothionein II*, Kagi, J.H.R. and Kojima, Y. eds. pp. 309-315, Birkhauser Verlag, Basel.
14. Murasugi, A., Wada, C. and Hayashi, Y. 1983. *J. Biochem.* 93: 661-664.
15. Rauser, W.E. 1987. *Plant Sci.* 51: 171-175.
16. Mutoh, N. and Hayashi, Y. 1988. *Biochem. Biophys. Res. Commun.* 151: 32-39.
17. Reese, R.N. and Wagner, G.J. 1987. *Plant Physiol.* 84: 574-577.
18. Berger, J.M., Jackson, P.J., Robinson, N.J., Lujan, L.D., Delhaize, E. 1989. *Plant Cell Reports*, 7: 632-635.
19. Rennenberg, H. 1982. *Phytochem.* 21: 2771-2781.
20. Delhaize, E., Jackson, P.J., Lujan, L.D. and Robinson, N.J. 1989. *Plant Physiol.* 89: 700-706.
21. Delhaize, E., Robinson, N.J. and Jackson, P.J. 1989. *Plant Molec. Biol.* 12: 487-497.

## EFFECTS OF HEAVY METALS ON ASSIMILATORY SULFATE REDUCTION IN PEA ROOTS

D. Schmutz, A. Rügsegger and C. Brunold

*Pflanzenphysiologisches Institut der Universität Bern, Altenbergrain 21, CH-3013 Bern*

*The high content of cysteine in the heavy metal sequestering phytochelatins ( $\gamma$ -Glu-Cys)<sub>n</sub>Gly (n = 2-11) led to the prediction that plants cultivated with heavy metals should contain increased levels of the enzymes involved in cysteine formation. Indeed, root sections of pea seedlings grown with Cd<sup>2+</sup> contained adenosine 5'-phosphosulfate sulfotransferase activity which was up to almost 20 fold higher than in controls. There was a parallel increase in glutathione synthetase, indicating that glutathione ( $\gamma$ -Glu-Cys-Gly) is involved in phytochelatin synthesis.*

In Cd-treated cell cultures of *Rauvolfia serpentina*, the structure of heavy metal binding peptides was found to be ( $\gamma$ -Glu-Cys)<sub>n</sub>Gly (n = 2-7) by Grill *et al.*<sup>1</sup>; they called this class of natural products phytochelatins. Their findings were in accordance with those of Murasugi *et al.*<sup>2</sup> and Kondo *et al.*<sup>3</sup> who found corresponding peptides in Cd treated yeast and called them cadystin A (n = 3) and B (n = 2). Further reports showed the production of phytochelatins in several plant species, and the induction of these compounds by other metal ions than Cd<sup>2+</sup>. Because of the  $\gamma$ -glutamic-acid bonds in the peptide chains of phytochelatins these compounds can not be primary gene products.

The extraordinary high cysteine content of phytochelatins makes an increased rate of assimilatory sulfate reduction probable in plants exposed to Cd. This prediction has been tested in maize<sup>4</sup>, by measuring two enzymes of this pathway leading to cysteine. Indeed, the activities of ATP-sulfurylase and adenosine 5'-phosphosulfate sulfotransferase (APSSTase) were at increased levels in maize seedlings cultivated with Cd. Nitrate reductase, which also had been measured in maize seedlings showed a decrease in the extractable activity in plants treated with Cd. This can probably be explained by the fact, that the molar ratio of N:S is 2.5:1 in phytochelatins, while it is about 25:1 in proteins. Therefore, plants producing high amounts of phytochelatins need relatively less nitrogen than control plants. Maize plants have a medium sensitivity towards Cd, therefore we also tested pea plants to examine if the high sensitivity of these plants is the consequence of an insufficient capacity of sulfate assimilation<sup>5</sup>. There was again an increase in the activity of APSSTase in roots of plants treated with 5-50  $\mu$ M CdCl<sub>2</sub>. Figure 1 shows the effect of 20  $\mu$ M Cd on the activity of APSSTase in different root sections. There was an increase in APSSTase activity in all sections. The highest activity was found in the section at the basis of the roots, where Cd<sup>2+</sup> induced an almost 20 fold increase in enzyme activity. At the same time, the *in vivo* incorporation of <sup>35</sup>S into the amino acid fraction of Cd treated roots, in which the PC's can be found, increased by more than 200% (Fig. 2). This finding is not only consistent with the results from the measurement of APSSTase, but it also indicates *de novo* synthesis of the cysteine used for phytochelatins from

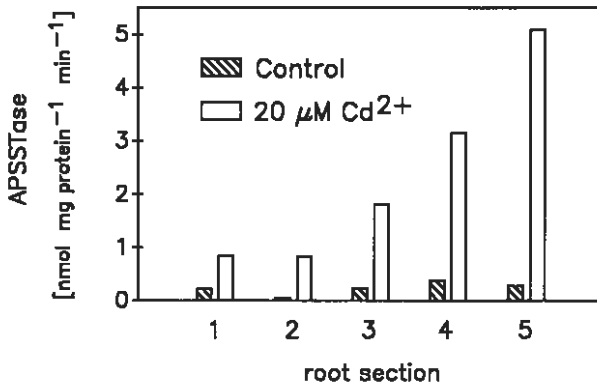

Fig. 1. Distribution of the activity of adenosine 5'-phosphosulfate sulfotransferase in roots of 9 days old pea seedlings, cultivated without  $\text{Cd}^{2+}$  or with  $20 \mu\text{M Cd}^{2+}$  for 2 days. The main root was cut into 2 cm long sections from the tip (section 1) to the basis (section 5). Methods: Pea seeds (*Pisum sativum* L. cv. Frühbusch, Vatter, Bern, Switzerland) were germinated and cultivated on 330 ml nutrient solution<sup>8</sup> at 21-24°C and  $50 \mu\text{E m}^{-2} \text{sec}^{-1}$ .  $20 \mu\text{M CdCl}_2$  was added 5 days after germination and adenosine 5'-phosphosulfate sulfotransferase activity was measured 2 days later according to Brunold and Suter<sup>9</sup> with the addition of 200 mM  $\text{Na}_2\text{SO}_3$  to the assay mixture and incubation under aerobic conditions.

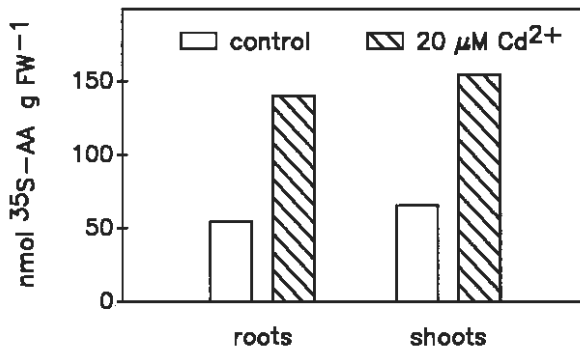

Fig. 2. *In vivo* incorporation of  $^{35}\text{S}$  into the amino acid fraction of roots and shoots of 10 days old pea seedlings cultivated without  $\text{Cd}^{2+}$  or with  $20 \mu\text{M Cd}^{2+}$  in the presence of  $^{35}\text{SO}_4^{2-}$ . Methods: 4 Plants were cultivated for 3 days on 100 ml nutrient solution in the presence of  $^{35}\text{SO}_4^{2-}$  ( $5 \text{ GBq/mole SO}_4^{2-}$ ), then  $20 \mu\text{M CdCl}_2$  was added to the nutrient solution and plants cultivated for another 3 days. Shoots and roots were extracted with 0.6 N NaOH, and proteins precipitated with  $\text{HClO}_4$ . The supernatant was used for the separation into a  $^{35}\text{SO}_4^{2-}$  and a  $^{35}\text{S}$ -amino acid fraction on columns packed with Dowex 50 W x 8 resin. Amino acids were retained by the resin and were eluted with 10% ammonia. The radioactivity in the amino acid fraction was counted in a liquid scintillation system.

the  $^{35}\text{SO}_4^{2-}$  applied.

Glutathione synthetase, which also has been measured in these experiments, showed an increase in the extractable activity in roots of seedlings treated with 20 or  $50 \mu\text{M Cd}$ . This finding together with the fact, that in tomato cell cultures, the glutathione content dropped to a low level after the induction of phytochelatin synthesis<sup>6</sup>, indicates a phytochelatin synthesis by transpeptidation or by dipeptide addition with glutathione as a precursor<sup>7</sup>

**References**

1. Grill, E., Winnacker, E.L. and Zenk, M.H. 1985. *Science* 230: 674-676.
2. Murasugi, A., Wada, C. and Hayashi, Y. 1981. *J. Biochem.* 90: 1561-1564.
3. Kondo, N., Imai, K., Isobe, M. and Goto, T. 1984. *Tetrahedron Lett.* 25: 3869-3872.
4. Nussbaum, S., Schmutz, D. and Brunold, C. 1988. *Plant Physiol.* 88: 1407-1410.
5. Rügsegger, A., Schmutz, D. and Brunold, C., submitted for publication.
6. Scheller, H.V., Huang, B. and Hatch, E. 1987. *Plant Physiol.* 85: 1031-1035.
7. Rennenberg, H. 1987. In: *Plant molecular biology*, von Wettstein, D. and Chua, N.H. eds. pp. 279-292, Plenum Publishing Corporation.
8. Wyss, H.-R. and Brunold, C. 1979. *Planta* 147: 37-42.
9. Brunold, C. and Suter, M. 1983. *Bot. Helv.* 93: 105-114.

# DETOXIFICATION OF XENOBIOTICS IN SPRUCE TREES IS MEDIATED BY GLUTATHIONE-S-TRANSFERASES

Peter Schröder<sup>1</sup>, Donald G. Rusness<sup>2</sup>, and Gerald L. Lamoureux<sup>2</sup>

<sup>1</sup> Fraunhofer Institute for Atmospheric Environmental Research, Kreuzteckbahnstr. 19, D-8100 Garmisch-Partenkirchen, F.R.G.

<sup>2</sup> USDA, ARS Biosciences Research Laboratory, P.O. Box 5674, State University Station, Fargo, ND 58105, U.S.A.

*Glutathione-S-transferases (GSTs) represent a group of enzymes that catalyze the conjugation of reduced glutathione (GSH) via its sulfhydryl group to a number of electrophilic xenobiotics<sup>1</sup>. This conjugation usually results in the detoxification of these compounds, and in animals it also facilitates their removal from the tissues. The GSTs from mammals, insects, and crop plants, have been intensively studied, but there is almost no information available on the presence or nature of these enzymes in forest trees. The present study focuses on the occurrence of GSTs in spruce (*Picea spec.*) which is one of the most important forest trees of the northern hemisphere. Several xenobiotics are shown to be metabolized by enzyme extracts in vitro as well as by whole needles and cultured cells in vivo.*

In incubations with cut needles of *Picea glauca* [L.] Moench, with cells from a dark-grown *Picea abies* [L.] Karst cell suspension culture, and with a dark-grown *Picea abies* [L.] Karst callus culture, [<sup>14</sup>C-CF<sub>3</sub>]-fluorodifen was metabolized to water soluble conjugates, Table 1. Since fluorodifen does not undergo appreciable nonenzymatic conjugation, the presence of these conjugates was suggestive of the presence of GST activity in spruce cells.

The conjugation rates were rather low in needles of *P. glauca* (0.7 pmoles/g FW), faster in *P. abies* callus culture (0.9 nmoles/g FW), but the fastest rate of conjugation was observed in the *P. abies* cell suspension culture (8.8 nmoles/g FW), Table 1. The conjugates from the needle and suspension culture experiments were purified by TLC and HPLC. One single metabolite was found in the cut needle incubation. It was identical to a major metabolite formed by the suspension cultures which was subsequently identified as glutathione conjugate of fluorodifen [S-(4-trifluoromethyl-2-nitrophenyl)glutathione] by TLC, HPLC, and fast atom bombardment (FAB) mass spectral comparison to an authentic standard. The main metabolite found in the *P. glauca* suspension cultured cells was a  $\gamma$ -glutamylcysteine conjugate of fluorodifen. Together with the observation that a cysteine conjugate of fluorodifen could also be detected after 20 h, it appears that the first two steps in the catabolism of glutathione conjugates in spruce is the same as in *Zea mays*<sup>1</sup>.

The conjugates of fluorodifen were observed in the medium outside of the needles and in the medium outside of the culture cells in appreciable amounts (Table 1). Further studies will be necessary to determine if the presence of the glutathione conjugate in the media is due to the presence of GST enzyme in the cell wall, leakage of metabolites from damaged cells, or if it is due to efflux of metabolites from normal cells.

The presence of GST activity in *P. abies* needles was verified by *in vitro* studies



**Table 1.** *In vivo* experiments with fluorodifen. *P. glauca* needles (0.5 g) were cut into 2 mm segments, vacuum-infiltrated with 0.5 ml potassium-phosphate buffer (0.1 M, pH 7.8) containing 60 nmol of the [<sup>14</sup>C]-herbicide, and incubated for 20 h at 30°C. Incubations were terminated by withdrawing the incubation medium and grinding the tissue in liquid N<sub>2</sub>. After extracting the tissue with 70% acetone and centrifugation, the supernatant as well as the incubation medium were subjected to phase partitioning with methylene-chloride/ aqueous 1% acetic acid. Radioactivity in all phases was quantitated by liquid scintillation spectrometry. The metabolite was extracted from the phases and identified by TLC and HPLC. *P. abies* callus cells were grown on agar medium<sup>5</sup>, treated with 60 nmol [<sup>14</sup>C]-herbicide dissolved in 30 µl of acetone and incubated for 20 h at 30°C. Conjugates were extracted as described above; radioactivity was quantitated by liquid scintillation spectrometry. *P. abies* suspension culture (50 ml) in a 250 ml flask was treated with 500 nmol [<sup>14</sup>C]-fluorodifen dissolved in 0.2 ml of acetone and incubated. After 20 hr the cells were filtered and the radioactive metabolites were extracted, purified by HPLC, and identified by FAB/MS.

	Medium conjugate formation in 20 hr [nmoles/g FW]	Tissue	Sum	Conjugate type
<i>P. glauca</i> needles	0.23	0.49	0.72	GSH
<i>P. abies</i> callus	0.52	0.40	0.92	GSH & related
<i>P. abies</i> suspension culture	1.28 0.00	2.30 3.90	3.58 3.90	GSH γ-Glu-Cys
	0.94	0.35	1.29	Cys
total	2.22	6.55	8.77	

**Table 2.** Kinetic properties of GST from *P. abies* needles. The needles of *Picea abies* were pulverized in liquid nitrogen and extracted with 0.1 M, pH 7.8 phosphate buffer, in the presence of 1.5 parts polyvinylpyrrolidone (w:w) and 0.5% Triton-X-100™ detergent. The extracted enzyme was fractionated by ammonium sulfate precipitation (40 to 60 % of saturation) and dialyzed before use. The resulting enzyme preparations were incubated with 0.1 M potassium phosphate buffer, 1 mM CDNB (1-chloro-2,4-dinitrobenzene), and 1mM GSH in a total volume of 3 ml. Conjugate formation was monitored by a change in absorption at 340 nm. Reactions were corrected for controls without enzyme extract.

Specific activity (tested with GSH/CDNB)	220 nmoles/min·mg protein
pH-optimum	7.6 – 8.0
K <sub>m</sub> (GSH)	0.14 mM
K <sub>m</sub> (CDNB)	0.67 mM

with 1-chloro-2,4-dinitrobenzene (CDNB) as the substrate. Enzyme activity was determined using a standard spectrophotometric assay<sup>2</sup>. The data in Table 2 indicate that the GST activity in *P. abies* is low compared to other plant tissues that have been investigated<sup>1</sup>.

Pentachloronitrobenzene (PCNB) fungicide is widely used to protect crop plants from a variety of plant pathogens. This fungicide is slightly toxic to higher plants and is metabolized to three different glutathione conjugates in peanut<sup>3</sup>: to *S*-(pentachlorophenyl)glutathione by displacement of a nitro group, to *S*-(aryl-tetrachloronitrophenyl)glutathione by displacement of a chlorine, and to *S,S*-(tetrachlorophenyl)-diglutathione by displacement of both a chlorine and a nitro group. The enzyme extracts from needles of *P. abies* were able to utilize [<sup>14</sup>C]-PCNB as a substrate (Fig. 1). The reaction was clearly dependent upon both the enzyme extract and gluta-

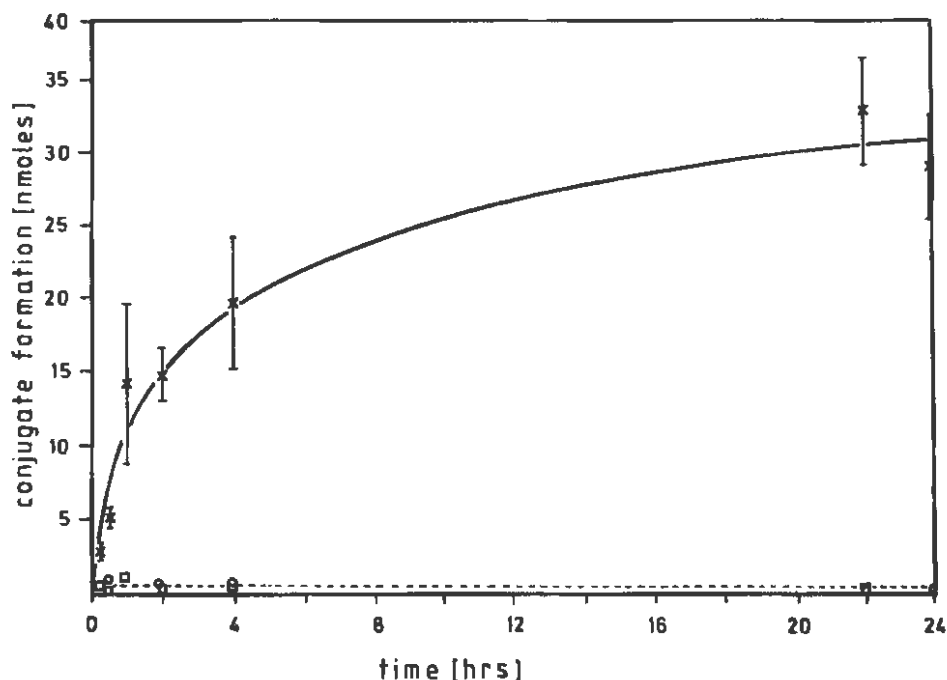

Fig. 1. Time study with PCNB. The enzyme extract of *Picea glauca* was prepared as described in Table 2. [ $^{14}\text{C}$ ]-PCNB in aqueous 5% acetone was added to enzyme extracts of *Picea glauca* and incubated at 30°C. Samples were withdrawn at constant intervals to monitor the time course of the reaction. After 24 h, the reaction was stopped and the parent PCNB and product(s) were extracted as described for the fluorodifen reactions (Table 1). Products were identified by TLC, HPLC, and FAB-MS. x-x enzyme incubation, controls: o-o no enzyme, □-□ no GSH.

thione. The initial rate of the reaction was estimated at 1.5 nmoles/h·mg protein and a final conversion to 80% water-soluble metabolites was observed in 24 hr. Although two major products were detected from this enzymatic reaction, only one of these products [*S*-(pentachlorophenyl)glutathione] was identified. This product had TLC, HPLC and FAB mass spectral properties identical to the standard.

Atrazine is an inhibitor of photosynthesis and it is widely used as a herbicide for controlling weeds in corn (*Zea mays*). Although atrazine is not volatile, some data suggest that atrazine may be transported in aerosols or in particulate matter from agricultural areas to remote forests in Bavaria<sup>4</sup>.

Enzymatic conjugation with glutathione is the primary mechanism of atrazine detoxification in atrazine-resistant monocotyledonous plants such as corn, sorghum, and sugarcane. Susceptible species, such as broadleaf weeds and grasses, are not able to detoxify atrazine by this mechanism. Enzyme extracts from *P. glauca* and *P. abies* were evaluated for their ability to detoxify atrazine by conjugation with glutathione. The extracts were incubated with [ $^{14}\text{C}$ ]-atrazine at 30°C as described for PCNB. Both, the enzyme extracts from *P. abies* and *P. glauca* had no activity towards atrazine under these conditions.

Preliminary studies with *Picea abies* and *Picea glauca* have shown that these spe-

cies contain GST enzymes that are active with several xenobiotics, including a herbicide and a fungicide. However, the level of GST activity observed in these conifers appears to be somewhat lower than that observed in some crop species. Additional studies are needed to determine if the level of GST activity and the range of GST isozymes present in *Picea* is sufficient to protect these trees from damage due to airborne pollutants. It also appears that the effect of airborne atrazine on spruce trees should be studied in more detail since atrazine does not appear to be metabolized by the GST enzymes from spruce.

### Acknowledgement

The *P. abies* callus culture used in the present experiments was a gift kindly provided by Prof. Dr. M.H. Zenk, University of Munich.

### References

1. Lamoureux, G.L. and Rusness, D.G. 1989. In: Glutathione: Chemical and medical aspects, Vol. III B, Series: Enzymes and cofactors, Dolphin, D. Poulson, R. and Avramovic, O. eds. John Wiley & Sons, New York.
2. Habig W.H., Pabst M.J. and Jacoby W.B. 1974. J. Biol. Chem. 249: 7130-7139.
3. Lamoureux, G.L. and Rusness, D.G. 1980. J. Agric. Food Chem. 28: 1057-1070.
4. Elling W., Huber, S.J., Blankenstahl, B. and Hock, B. 1988. Environ. Pollut. 48: 77-82.
5. Gamborg, O.L., Miller, R.A. and Ojima, K. 1968. Exp. Cell Res., 151-158.

# DIURNAL CHANGES IN THE THIOL COMPOSITION OF SPRUCE NEEDLES

R. Schupp and H. Rennenberg

*Fraunhofer Institut für Atmosphärische Umweltforschung, Kreuzeckbahnstr. 19, D-8100 Garmisch Partenkirchen, F.R.G.*

*In spruce needles and twig axes, the concentrations of glutathione  $\gamma$ -glutamylcysteine, but not of cysteine, undergo light-dependent diurnal changes. In the needles the glutathione concentration was high during midday and low during the night. The glutathione concentration in the twig axes and the  $\gamma$ -glutamylcysteine concentrations in the needles proceeded in inverse daily changes. It, therefore, may be assumed that (1) synthesis of glutathione from  $\gamma$ -glutamylcysteine and (2) transport of glutathione between needles and twig axes account for the diurnal variations of glutathione in the needles. Considering the amplitudes of the observed fluctuations and the weight ratios of needles and twig axes these processes could only contribute to part of the alterations of the glutathione concentration in the needles. The involvement of additional regulatory factors is discussed.*

The tripeptide glutathione ( $\gamma$ -L-glutamyl-L-cysteinyl-glycine) is the most abundant low-molecular-weight, soluble thiol in plant cells<sup>1</sup>. On a cellular basis, its concentration varies from 0.1 to 0.7 mM depending on the plant species analyzed<sup>1</sup>. Some of the factors affecting the cellular concentration of glutathione have been analyzed in leaves of conifers. *E.g.* in spruce needles, glutathione undergoes an annual rhythm with high concentrations in winter and spring and low concentrations during the summer<sup>2</sup>; the concentration of glutathione changes with the elevation of the forest stand<sup>3</sup> and depends on the nutritional status of the plant. In needles of spruce trees exposed to SO<sub>2</sub> an increased level of glutathione was observed<sup>4-6</sup>. In spinach plants fumigation with H<sub>2</sub>S resulted in an accumulation of glutathione and cysteine in the light, whereas the  $\gamma$ -glutamylcysteine content increased during darkness<sup>7</sup>. Because of the inverse fluctuation of both thiols Buwalda *et al.*<sup>7</sup> concluded that degradation of glutathione to, and its synthesis from  $\gamma$ -glutamylcysteine are the processes responsible for the light-dependent changes in the glutathione content of the leaves. Although laboratory experiments with several plant species clearly showed that light affects the concentration of glutathione in green tissue<sup>7-11</sup>, the regulatory factors mediating these fluctuations have so far not been elucidated. The present experiments were performed to investigate light-induced changes in the thiol composition of spruce trees growing in the field.

The glutathione concentration in spruce needles increased during the morning reaching its maximum level of 0.28 mM at about 14.00 h. It decreased later during the afternoon and remained relatively constant at its minimum level of 0.18 mM during the night (Fig. 1A, 2A).

Whereas the cysteine content of the needles did not show significant changes within a 24 hour period (Fig. 1C), the  $\gamma$ -glutamylcysteine content varied in a way inverse to the glutathione concentration (Fig. 1B). To investigate the light-dependence of

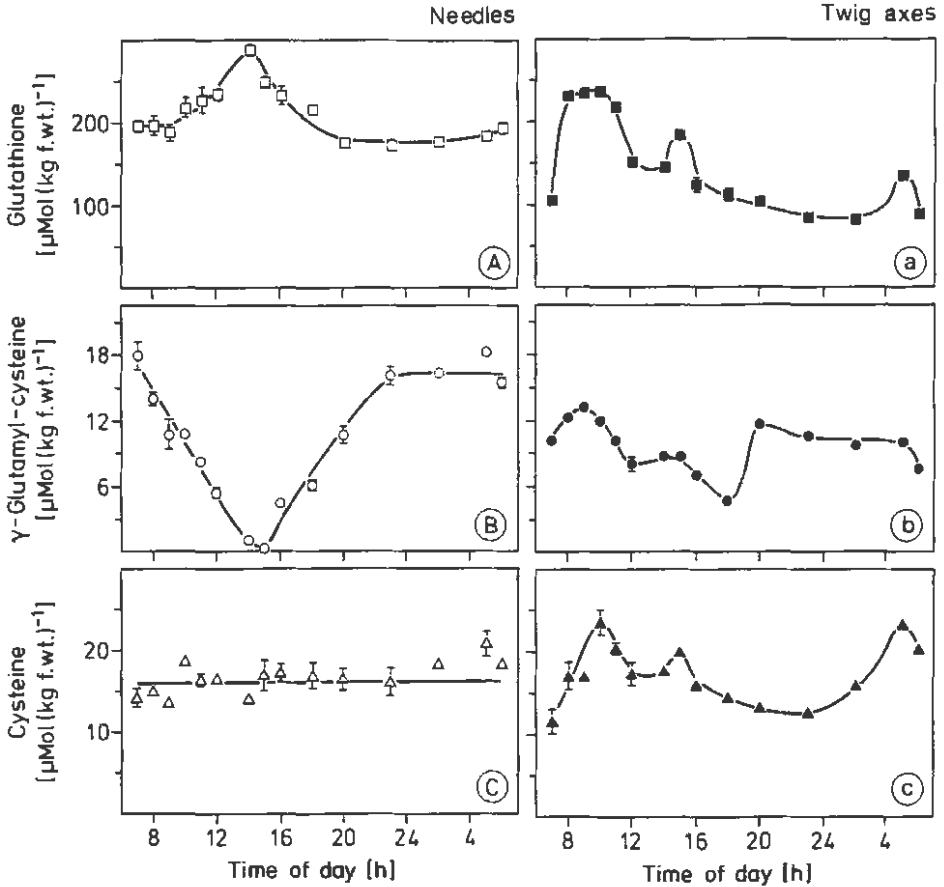

**Fig. 1.** Diurnal fluctuations in the thiol composition of needles and twig axes of Norway spruce. Needles (Fig. 1A-C) and twig axes (Fig. 1a-c) were harvested within a 24 hour period beginning at 7 a.m. and stored in liquid nitrogen. Extractions of homogenized samples were derivatized with monobromobimane. Separation of the derivatives of glutathione ( $\square - \square$ ,  $\blacksquare - \blacksquare$ ),  $\gamma$ -glutamylcysteine ( $\circ - \circ$ ,  $\bullet - \bullet$ ) and cysteine ( $\triangle - \triangle$ ,  $\blacktriangle - \blacktriangle$ ) was achieved by reverse-phase HPLC. Methods: Experiments were performed with a group of three isolated spruce trees approximately 100-150 years old with apparently healthy appearance. Branches were cut on the western side of the trees 2.0-3.0 m above ground. After separation needles and twig axes were stored separately in liquid nitrogen. Frozen needle powder or pieces of twig axes were extracted as previously described<sup>12</sup>. Homogenization was performed at 4°C by three strokes, 30 seconds each, with an Ultra Turrax blender (Janke and Kunkel, Typ 25, Staufen, F.R.G.) at 24,000 rpm in a suspension of 0.1 N hydrochloric acid, 1 mM EDTA and 6 % (w/v) insoluble PVP; six aliquots of each sample containing 0.2 g fresh weight needles or 0.4 g fresh weight twig axes were extracted with 7 ml or 14 ml extraction medium, respectively. For recovery analysis 40 nmol GSH, 8 nmol cysteine and 4 nmol  $\gamma$ -glutamylcysteine was added to half of the needle extracts prior to homogenization; for analysis of twig axis the amounts of internal standards were doubled. After centrifugation at 48,000  $\times$  g aliquots of the supernatant fractions were neutralized with 200 mM CHES buffer, pH 9.3, and subjected to reduction with DTT. Thiols were derivatized by addition of monobromobimane solution (Calbiochem, La Jolla, USA). Separation and quantification of the derivatives was achieved by reverse phase HPLC on a RP-18 column (250 mm  $\times$  4.6 mm i.d., ODS-Hypersil, 5  $\mu$ m pore size; Bischoff, Leonberg, F.R.G.) and fluorimetric detection at 480 nm by excitation at 380 nm. Aqueous 0.25 % acetic acid (pH 3.9) containing a gradient of 10 % to 14 % methanol was used for elution. PAR was measured with a quantum meter (Li-185B; quantum sensor Li 190Sb; Li-Cor Inc., Lincoln, USA). Temperature was monitored continuously with a general purpose temperature probe (AC 2626, Analog Devices, Norwood, UK). The data shown are means of two independent experiments with 3 replicates each. For some data standard deviations were too small to be considered in the graph.

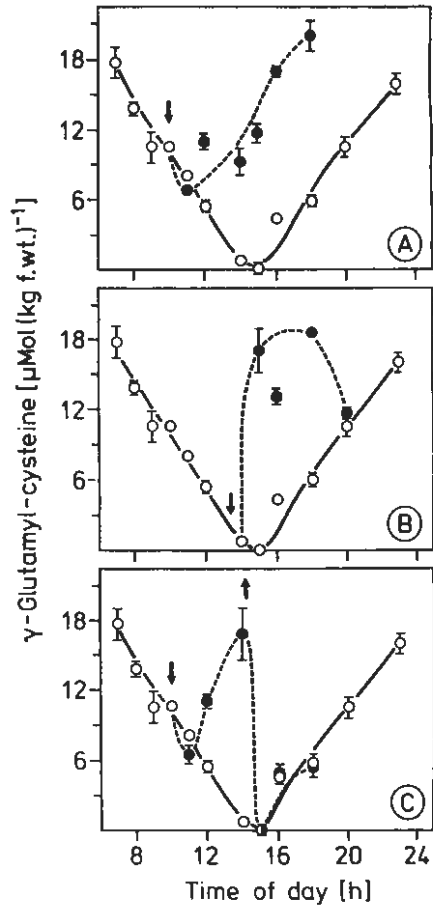
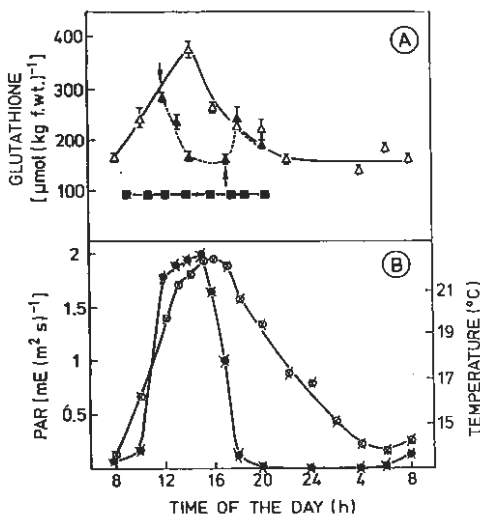

Fig. 2 and 3. Light dependence of the glutathione and  $\gamma$ -glutamylcysteine concentrations in spruce needles. At the time of the day indicated needles were harvested from twigs of the same branch, either exposed to natural light conditions (open symbols), or shaded by enclosure in a black cotton bag (closed symbols). Arrows indicate the addition (↓) or removal (↑) of the bag. Both the glutathione and  $\gamma$ -glutamylcysteine content (Fig. 3) of the needles were measured in uncovered controls ( $\Delta$  -  $\Delta$ ,  $\circ$  -  $\circ$ ), in needles of branches enclosed in a black bag very early in the morning ( $\blacksquare$  -  $\blacksquare$ ), or during late morning ( $\blacktriangle$  -  $\blacktriangle$ ,  $\bullet$  -  $\bullet$ ). For one of the experiments temperature ( $\times$  -  $\times$ ) and PAR ( $\times$  -  $\times$ ) are shown in Fig. 2B. Inside the bag light intensities were lower than  $20 \mu\text{E (m}^2 \text{sec}^{-1}\text{)}$ , temperatures were 1-2 $^{\circ}\text{C}$  higher than in ambient air. Thiol analysis was performed as described in Fig. 1.

these inverse diurnal changes, branches were covered with a black cotton bag. Light intensities of up to  $20 \mu\text{E (m}^2 \text{s}^{-1}\text{)}$  and 1-2 $^{\circ}\text{C}$  higher temperatures were measured inside the bag. When branches were enclosed in the bag at 8.00 h, the glutathione concentration of the spruce needles did not increase during the day but remained constant at its minimum level (Fig. 2A). Enclosing branches in the bag within the period of increasing glutathione and decreasing  $\gamma$ -glutamylcysteine concentrations caused the glutathione content of the needles to decrease immediately (Fig. 2A), but the  $\gamma$ -glutamylcysteine content to increase (Fig. 3A, B); when the bag was removed, the

concentration of both thiols was adjusted to the level observed in uncovered controls (Fig. 2A, 3C). Because of its approximately 5 times lower diurnal amplitude as compared to glutathione, the changes of the  $\gamma$ -glutamylcysteine are too small to account for the total changes in the glutathione content within a 24 hour period. Apparently, light-dependent synthesis of glutathione from  $\gamma$ -glutamylcysteine and degradation of glutathione to this dipeptide can only be responsible for less than 20% of the diurnal fluctuations in the glutathione content of spruce needles (Fig. 1A, B).

Therefore, the concentrations of the thiols in the twig axes of needles were analyzed. The thiols in the twig axes showed alterations within a 24 hour period different from those observed in the needles (Fig. 1a-1c). Only the patterns of the  $\gamma$ -glutamylcysteine concentrations in needles and twig axes resembled each other with low concentrations during midday and high concentrations during the night (Fig. 1B, 1b). However, the diurnal amplitude in the twig axes amounted to only half the amplitude found in the needles. In addition, the decline in the  $\gamma$ -glutamylcysteine concentration of the twig axes in the morning and the resultant minimum concentration during midday, was delayed as compared to the needles. The patterns of the cysteine and glutathione concentrations in the twig axes (Fig. 1c, a) are quite similar, although the cysteine content of the needles did not show significant changes within a 24 hour period. In the light, the glutathione concentrations in the twig axes changed in a way inverse to the glutathione concentrations of the corresponding needles. In fact, the diurnal amplitudes of glutathione in needles and twig axes were with 0.1 mM almost identical. But concerning the fresh weight of the twig axes, which amounted to only  $18.3 \pm 8.3$  % of the total fresh weight of the twig needles plus twig axes, transport processes between needles and corresponding twig axis might contribute to less than 20 % of the diurnal fluctuations in the glutathione content of the needles. Buwalda *et al.*<sup>7</sup> could explain the light-dependent changes in the pools of glutathione and  $\gamma$ -glutamylcysteine in spinach leaves with an interconversion of the two thiols. From the present experiments it appears that additional processes participate in the light-dependent changes in spruce. Either transport of glutathione from other parts of the trees to the needles and/or *de novo* sulfate reduction and assimilation might be responsible for the increasing glutathione concentrations during the morning. In the latter case, the availability of O-acetylserine for cysteine synthesis<sup>13</sup> and/or enhanced APS-sulfotransferase activity<sup>14</sup> have to be considered as regulating factors.

In the present experiments the same diurnal variations were observed when DTT or  $\text{NaBH}_4$  was used as a reductant during the extraction of glutathione.  $\text{NaBH}_4$ , but not DTT is a reductant sufficiently strong to reduce glutathione-mixed-disulfides with proteins and other cellular thiol components. Therefore, the finding of diurnal changes when  $\text{NaBH}_4$  was used as a reductant is evidence that the degradation of mixed disulfides is not a significant factor in the light-dependent increase in the concentration of glutathione.

From the data presented, it can not be excluded that the decline in the glutathione content of the needles in the afternoon is mediated by the degradation of glutathione via cysteine to hydrogen sulfide that may be emitted into the atmosphere<sup>15,16</sup>. However, recent experiments with attached branches of spruce trees did not show significant differences in the hydrogen sulfide emission during the morning and the afternoon (Rennenberg, unpublished results). Therefore, an export of glutathione from the needles to other parts of the tree as previously observed with other

plants<sup>17-19</sup> may be responsible for the decline in the glutathione content of spruce needles in the afternoon. Such a transport may take place in analogy to the carbon allocation of plants, which was also found to exhibit diurnal changes<sup>20</sup>.

Further experiments are needed to evaluate the impact of long-distance transport versus metabolic processes in the diurnal fluctuations in the glutathione concentration in spruce needles.

## References

1. Rennenberg, H. 1982. *Phytochem.* 21: 2271-2781.
2. Esterbauer, H. and Grill, D. 1978. *Plant Physiol.* 61: 119-121.
3. Grill, D., Pfeifhofer, H., Tschulik, A., Hellig, K. and Holzer, K. 1988. *Oecologia* 76: 294-297.
4. Grill, D. and Esterbauer, H. 1973. *Europ. J. Forest. Pathol.* 3: 65-71.
5. Grill, D., Esterbauer, H. and Klösch, U. 1979. *Environ. Pollut.* 17: 187-194.
6. Grill, D., Esterbauer, H. and Hellig, K. 1982. *Phytopath. Z.* 104: 264-271.
7. Buwalda, F., De Kok, L.J., Stulen, I. and Kuiper, P.J.C. 1988. *Physiol. Plant.* 74: 663-668.
8. Manetas, Y. and Gavalas, N.A. 1983. *Plant Physiol.* 71: 187-189.
9. Bielawski, W. and Joy, K.W. 1986. *Planta* 169: 267-272.
10. Shigeoka, S., Onishi, T., Nakano, Y. and Kitaoka, S. 1987. *Agric. Biol. Chem.* 51: 2257-2258.
11. Koike, S. and Patterson, B.D. 1988. *Hort. Sci.* 23: 713-714.
12. Schupp, R. and Rennenberg, H. 1988. *Plant Sci.* 57: 113-117.
13. Rennenberg, H. 1983. *Plant Physiol.* 73: 560-565.
14. Brunold, C. 1981. In: *Biology of inorganic nitrogen and sulfur*, Bothe, H. and Trebst, A. eds. pp. 352-358, Springer, Berlin.
15. Filner, P., Rennenberg, H., Sekiya, R., Bressan, A., Wilson, G., Lecureux, L. and Shimei, T. 1984. In: *Gaseous air pollutants and plant metabolism*, Koziol, M.J. and Whatley, F.R. eds. pp. 291-312, Butterworths, London.
16. Rennenberg, H. 1984. *Annu. Rev. Plant Physiol.* 35: 121-153.
17. Rennenberg, H., Schmitz, K. and Bergmann, L. 1979. *Planta* 147: 47-62.
18. Bonas, U., Schmitz, K., Rennenberg, H. and Bergmann, L. 1979. *Planta* 147: 57-62.
19. Alosi, M.C., Melroy, D.L. and Park, R.B. 1988. *Plant Physiol.* 86: 1089-1094.
20. Gordon, A.J. 1986. In: *Phloem transport*, Cronshaw, J., Lucas, W.J. and Giaquinta, R.T. eds. pp. 499-517, Alan R. Liss Inc, New York.



## THE ROLE OF METAL-BINDING COMPOUNDS (PHYTOCHELATINS) IN THE CADMIUM-TOLERANCE MECHANISM OF BLADDER CAMPION (SILENE VULGARIS)

J.A.C. Verkleij\*, P.L.M. Koevoets\*, J. van 't Riet†, J.A. de Knecht\* and W.H.O. Ernst\*

\* *Department of Ecology of Ecotoxicology and † Biochemical Laboratory, Free University of Amsterdam, De Boelelaan 1087, 1081 HV Amsterdam, The Netherlands.*

*In roots of Cd-sensitive and -tolerant plants of Silene vulgaris 14.5 kDa cadmium-binding compounds are induced after exposure to Cd. Upon purification these compounds appeared to consist solely of Glx, Cys and Gly in a ratio of 3:3:1 or 2:2:1, respectively. These Cd-binding compounds are identical to the so-called phytochelatins. The 14.5 kDa compounds, containing most of the Cd that has been taken up by the plants, are probably associated forms of the much smaller phytochelatins. Both types of plants synthesized nearly similar amounts of phytochelatins upon Cd-stress. The amount of Cd bound to phytochelatins in the tolerant plants is about twice as high as in the sensitive ones. Presumably the Cd-thiopeptides do not only play a role in the detoxification of Cd but are also involved in the tolerance of the plants to Cd.*

Many plant species are known to have evolved metal tolerance in response to the occurrence of soils contaminated either naturally or artificially by toxic metals such as Zn, Cu, Pb and Cd<sup>1</sup>. A variety of mechanisms, dependent on the type of metal, has been proposed to explain metal tolerance. They include: exclusion of metals from the plant, compartmentation of metals in vacuoles and cell walls, evolution of metal tolerant enzymes and specific metal-binding proteins and peptides<sup>2</sup>. Especially in the case of Cu- and Cd-toxicity metal-binding peptides (poly( $\gamma$ -glutamylcysteinyl) glycine or phytochelatins) should sequester the metals by virtue of their high affinity for these toxic metals<sup>3,4</sup>.

*Silene vulgaris* is one of the pioneer species of heavy metal contaminated soils and Cd-tolerant as well as Cd-sensitive populations are known of this organism<sup>5</sup>. These populations are excellent objects to investigate the role of metal-binding compounds in the Cd-tolerance mechanism. Upon Cd-stress the biomass production and root growth differed quite significantly between Cd-tolerant and sensitive plants<sup>5</sup>. High amounts of cadmium, 90-95% of the total Cd-content on a whole plant basis, were found in the roots of the tolerant plants; less than 80% in the sensitive ones. Apart from the difference in root/shoot ratio of the Cd-concentration, it is obvious that the Cd-concentration in the roots by far exceeds that in the shoots. This means that, at least in the roots of tolerant plants, an effective detoxification mechanism must exist.

After chromatography of root-extracts of sensitive and tolerant plants, grown on

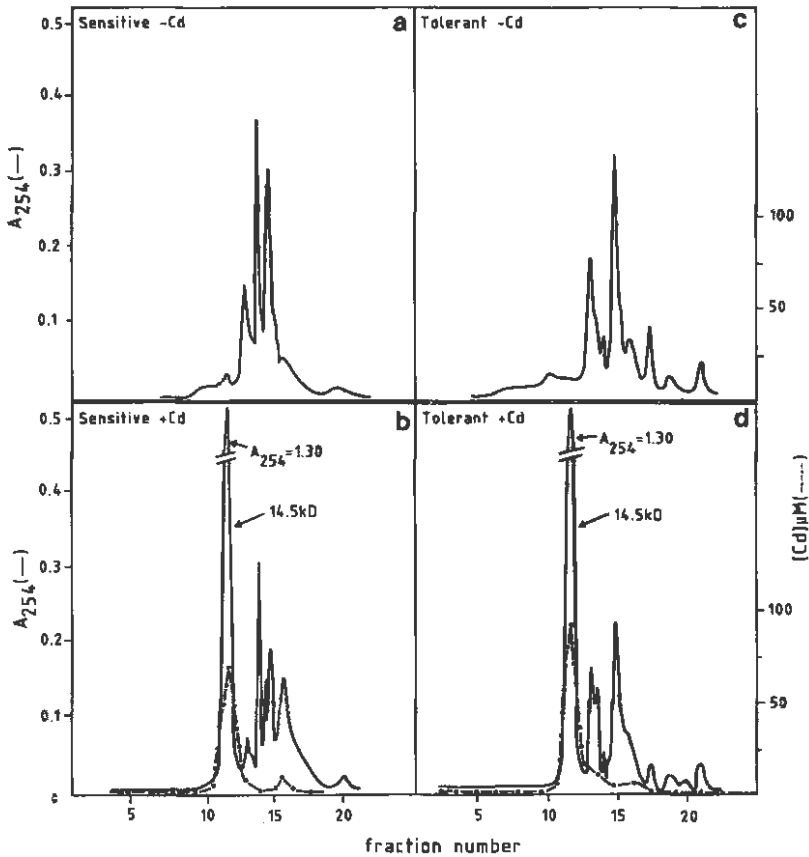

Fig. 1. FPLC-Superose 12 gel filtration profiles of root extracts of a Cd-tolerant (c,d) and a-sensitive (a,b) plant of *Silene vulgaris* after 3 weeks growth on 0  $\mu\text{M}$  (a,c) and 40  $\mu\text{M}$  Cd (b,d). Roots (4–5 g) from both tolerant and sensitive plants from the experiments with a cadmium concentration of 0  $\mu\text{M}$  (control treatment) and 40  $\mu\text{M}$  (cadmium treatment) were harvested, washed in deionized water and homogenized in 20 mM Tris-HCl, 5 mM  $\beta$ -mercaptoethanol and 1 mM phenylmethansulfonyl fluoride, pH 7.3 at 4°C using an Omnimixer (Sorvall, Du Pont, Del. USA). The slurry was strained through four layers of cheese-cloth and the filtrate was centrifuged at 100,000 g for 90 min at 4°C. Supernatants were applied on an FPLC-Superose 12 column (HR 10/30, Pharmacia LKB Fine Chemicals, Uppsala, Sweden). Elution (24 ml h<sup>-1</sup>) took place with NH<sub>4</sub>HCO<sub>3</sub> (100 mM, pH 8.0) at room temperature. Fractions (1.5 ml) were collected with a Pharmacia Frac 100 fraction collector and the effluents monitored at 254 nm. Cadmium in the fractions was determined by atomic absorption spectrophotometry (Perkin-Elmer 4000, Überlingen FRG).

0 and 40  $\mu\text{M}$  Cd, on a FPLC-Superose-12 column we obtained the following profiles (Fig. 1). Only in extracts from both types of plants, grown on 40  $\mu\text{M}$  Cd, one major Cd-containing peak with an apparent m.m. of 14.5 kDa and containing more than 90% of the cadmium, was present. No distinct Cd-containing peak with a lower Mol.Wt. was found in contrast to analyses of Cu-containing compounds in plants grown on 40  $\mu\text{M}$  Cu<sup>6</sup>. The  $A_{254}/A_{280}$  ratio of the 14.5 kDa peaks was about 1.5, suggesting the presence of mercaptide bonds. In extracts from plants, grown on a control solution, we could not detect these 14.5 kDa compound. Both tolerant and sensitive

Table 1. The amount of Cd (nmol/ $\mu$ g protein) bound to the 14.5 kDa,  $A_{254}$ -absorbing compound. Isolation and purification were similar to the methods described under Fig. 1 Cd was determined by atomic absorption spectrophotometry and protein with Coomassie Brilliant Blue R250<sup>14</sup>.

Cd-treatment	Cd-tolerant	Cd-sensitive
0	0.07 ( $\pm$ 0.01)	0.12 ( $\pm$ 0.02)
40	7.56 ( $\pm$ 0.23)	3.31 ( $\pm$ 0.21)

plants synthesized nearly the same amounts of Cd-binding compounds after Cd-treatment based on the absorption at 254 nm. However, the amount of Cd bound to the 14.5 kDa compound, calculated on protein basis, distinctly differed between the tolerant and sensitive plants (Table 1). A somewhat similar result was obtained in *Agrostis gigantea*, in which a Cd-tolerant clone produced in the roots more 'Cd-binding proteins' to which a higher percentage of Cd was associated compared with the sensitive clone<sup>7</sup>. The Mol.Wt. estimates of the observed Cd-binding compounds are of the same order of those obtained in tomato, cabbage and tobacco<sup>8,9</sup>.

Upon gelfiltration on Sephadex G-75 of the cell-free extracts of both plants, nearly all of the eluted Cd was associated with a high m.m., UV-absorbing fraction B (Fig. 2a,b). Cadmium was always present in the large m.m. complex and never eluted with the total included volume. The fractions, containing the highest Cd content (fractions 29, 30) were chromatographed on an anion-exchange FPLC-Mono-Q column and at 0.6 M NaCl one major Cd-containing peak eluted, which accounted for nearly 100% of the recovered metal (Fig. 3). We did not detect any difference in elution pattern between material obtained from Cd-tolerant or -sensitive plants. Peak-fractions obtained from anion-exchange chromatography were further purified on FPLC-Superose-12 gelfiltration. The elution profiles from both types of plants reveal only one peak with an apparent molecular mass of 14.5 kDa containing nearly all the recovered cadmium (Fig. 4a,b).

The amino-acid composition of the purified Cd-containing compounds from both types of plants revealed a striking similarity with the amino-acid composition of the so-called phytochelatins or poly( $\gamma$ -glutamyl cysteinyl)glycine: Glx, Cys and Gly accounted for more than 90% of all amino-acids in the ratio 2:2:1 (Table 2) or 3:3:1 respectively. These presumably bis- and tris-forms of phytochelatins were detected in the tolerant as well as in the sensitive plants. Furthermore, in the Cd-sensitive and -resistant *Datura* cell-suspension cultures only the bis- and tris-forms were present<sup>10</sup>. In the presence of Cd-ions these polypeptides form multimeric aggregates *in vivo*, which show high affinity to Cd and bind most of the soluble free Cd (> 90%). Acid-labile sulfide seems to be involved in the sequestration of Cd to these compound and could explain the difference in Cd-binding between tolerant and sensitive plants<sup>3</sup>.

After SDS-Polyacrylamide gel electrophoresis we detected low m.m. silver stainable compounds migrating with almost the same mobility as the tracking dye (Bromo Phenol Blue). They were only detectable in root extracts of both types of plants after exposure to high concentrations of cadmium.

There is now strong evidence that phytochelatins are produced in higher plants or plant cell suspension cultures, algae and fission yeast when exposed to Cd<sup>4</sup>. Our studies on Cd-sensitive and tolerant *Silene vulgaris* under Cd-treatment strongly suggest the induction of similar compounds, which are evidently related to these pep-

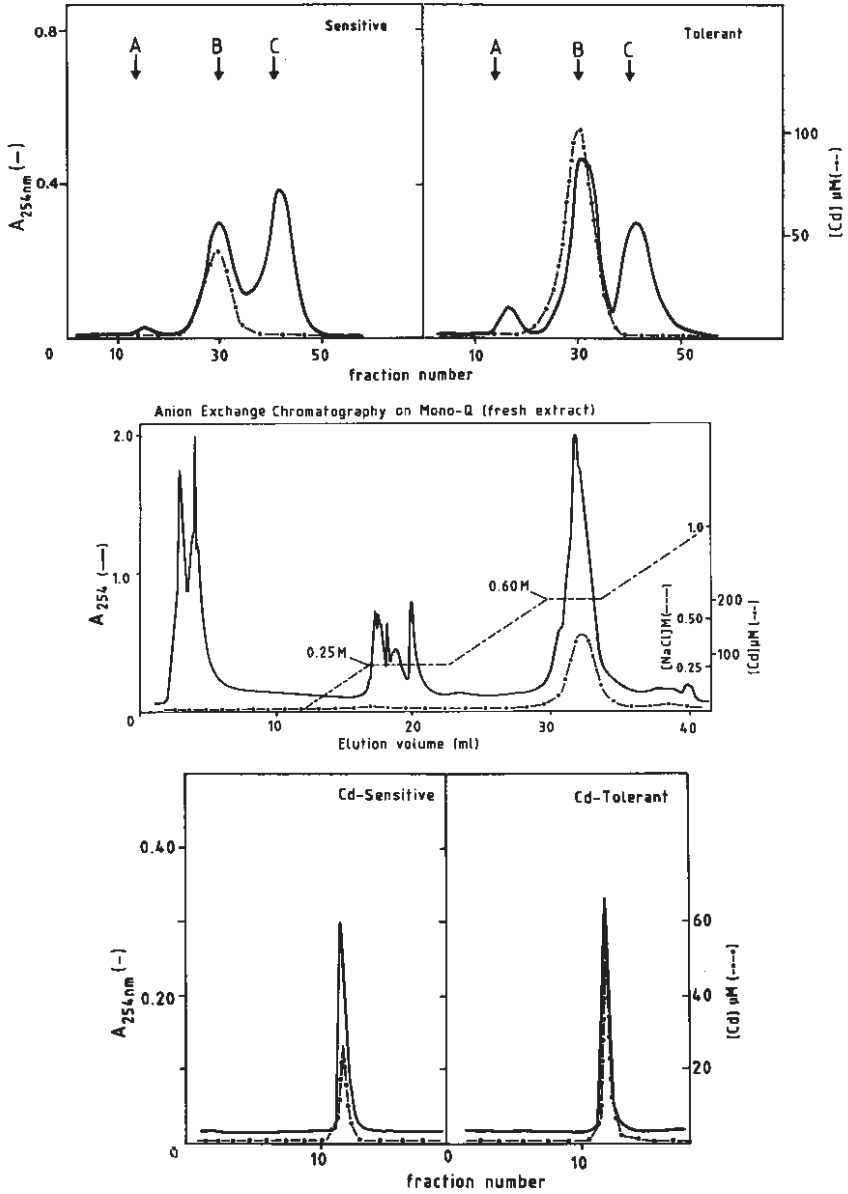

Fig. 2-4. In order to purify and characterize the cadmium-binding compounds supernatants were chromatographed on Sephadex G-75 column (Pharmacia). Elution ( $24 \text{ ml h}^{-1}$ ) was carried out with Tris-HCl (20 mM, pH 8.0) at  $4^\circ\text{C}$  (upper Figure). Top fractions obtained by G-75 filtration containing high concentrations of Cd were subsequently applied on FPLC-mon Q anion exchange chromatography column (HR 5/5) and eluted by a linear salt gradient (0.0-1.5 NaCl) in 20 mM Tris-HCl, pH 8.0. Top fractions obtained by anion exchange chromatography on FPLC-Mono Q (fractions from peak 1, middle Figure) were chromatographed on an FPLC superose 12 column (HR 10/30) equilibrated with 100 mM  $\text{NH}_4\text{HCO}_3$ , pH 8.0 (lower Figure). Cd was determined by AAS (Perkin & Elmer 1100 Graphite furnace). Columns were calibrated with BSA, trypsin inhibitor, cyt c, aprotinine, insuline, insuline- $\alpha$  and - $\beta$  chain having a m.m. of 134/67, 20.0, 12.5, 6.5, 5.7, 3.4 and 2.4 kDa, respectively.

**Table 2.** Amino-acid composition of 14.5 kDa Cd-binding compounds of root extracts of a Cd-sensitive (a) and a Cd-tolerant (b) *Silene vulgaris*. 0.5 ml fractions of 14.5 kDa Cd-containing material from the last purification step in a FPLC-Superose-12 column (following FPLC-Mono-Q anion exchange chromatography) were freeze dried, oxidized with performic acid, freeze dried and hydrolyzed in 6 N HCl with 0.01% phenol for 1 h at 150°C in evacuated sealed tubes, followed by phenylisothiocyanate (PITC) derivatization and separation by reversed phase (PP)HPLC<sup>15</sup>.

Amino Acid Residue	% of Total Residues	
	sensitive (a)	tolerant (b)
*Cysteine	31.2	33.9
Aspartate	3.0	1.4
Glutamate	33.2	35.2
Glycine	16.5	17.2
Serine	3.6	3.7
Histidine	0.6	0.5
Arginine	0.8	1.3
Threonine	1.6	0.6
Alanine	1.1	0.3
Proline	0.3	0.6
Tyrosine	2.7	2.4
Valine	0.9	0.6
Methionine	0.1	0.1
Isoleucine	1.4	0.4
Leucine	1.8	0.5
Phenylalanine	0.6	0.8
Lysine	1.2	0.5

\* Determined as half cystine.

tides. Because most of the cellular Cd appeared to be bound to this complex it seems obvious to conclude that these compounds play a key role in the Cd-detoxification mechanism.

However, it is doubtful if such compounds play a major role in naturally selected Cd-tolerance based on the following observations:

1. Cd-tolerant as well as sensitive plants produce approximately the same amount of PC when exposed to the same level of Cd-exposure.
2. Zn-tolerant plants of *Silene vulgaris* from a zinc-lead mine (containing very low levels of Cd) and Zn-Cd-tolerant ones from a zinc-lead-cadmium mine exhibit the same high Cd-tolerance. After exposure to Zn, PC-production seems to be absent in sensitive and -tolerant plants.
3. Most of the studies on PC-production under Cd-stress were performed with cell-suspension cultures of vegetables and crop plants. In fact, none of these species from which Cd-tolerant cell lines have been selected thus far, exhibits genetically evolved and fixed metal-tolerance at the level of the intact plant<sup>11</sup>.

Therefore, it is likely that these metal-binding peptides (PC) play a role in the homeostatic control of metal ions. This function may be important in response to extracellular concentrations and, in the case of essential micronutrients, in the intracellular control of the metal metabolism<sup>12</sup>, as was proposed for metallothioneins<sup>13</sup>. If PC are involved in the mechanism of metal-tolerance, their role is more limited and differentiated and cannot be generalized<sup>4</sup>. Resistance to metals in higher plants is mostly very specific and the primary toxic effects of metals in cells and organisms are hardly known<sup>2</sup>.

## Acknowledgement

We thank Mr. R. Bank (Institute of Anthropogenetics, FUA) for carrying out the amino acid analyses.

## References

1. Ernst, W.H.O. 1974. *Schwermetallvegetation der Erde*. Springer Verlag.
2. Verkleij, J.A.C. and Schat, H. 1989. In: *Mechanisms of metal resistance in higher plants*, Shaw, J. ed., CRC-Press, New York (in press).
3. Reese, R.N., Mehra, R.K., Tarbet, E.B. and Winge, D.R. 1988. *J. Biol. Chem.* 263: 4186-4192.
4. Grill, E., Winnacker, E.-L. and Zenk, M.H. 1987. *Proc. Natl. Acad. Sci. USA* 84: 439-443.
5. Verkleij, J.A.C. and Prast, J.E. 1989. *New Phytol.* 111: 637-645.
6. Verkleij, J.A.C., Koevoets, P.L.M., Van 't Riet, J., Van Rossenberg, M.C., Bank, R. and Ernst, W.H.O. 1989. In: *Metal ion homeostasis: molecular biology and chemistry*, Winger, D. and Hamer, D., eds., pp. 347-357, Alan R. Liss, New York.
7. Rauser, W.E. 1986. *Plant Sci.* 43: 85-91.
8. Wagner, G.J. 1984. *Plant Physiol.* 76: 797-805.
9. Wagner, G.J. and Trotter, M.M. 1982. *Plant Physiol.* 69: 804-809.
10. Jackson, R.J., Unkefer, C.J., Doolen, J.A., Watt, K. and Robinson, N.J. 1987. *Proc. Natl. Acad. Sci. USA* 84: 6619-6623.
11. Woolhouse, H.W. 1983. In: *Encyclopedia of Plant Physiology, New Series 12*, Lange, O.L. et al. eds., pp. 245-300, Springer, Berlin.
12. Robinson, N.J. and Jackson, P.J. 1986. *Physiol. Plant.* 67: 499-506.
13. Karin, M. 1985. *Cell* 41: 9-10.
14. Peterson, G.L. 1984. *Methods in Enzymology* 91: 108-110.
15. Bidlingmeyer, B.A., Cohen, S.A. and Tarvin, T.L. 1984. *J.Chrom.* 336: 93-104.

# EFFECT OF CHILLING ON GLUTATHIONE REDUCTASE AND TOTAL GLUTATHIONE IN SOYBEAN LEAVES (*GLYCINE MAX* (L) MERR)<sup>1</sup>

Thomas L. Vierheller and Ivan K. Smith

Department of Botany, Ohio University, Athens, Ohio 45701, USA

*Exposure of cold-sensitive soybean plants (Glycine max (L) Merr) to chilling temperatures (5°C) had little effect on the kinetic characteristics of glutathione reductase (GR) (EC 1.6.4.2). Highest affinity for substrates was found to occur at lower assay temperatures. At saturating substrate concentrations, the rate of oxidized glutathione reduction in vitro had a  $Q_{10}$  of 2 in the temperature range of 5°C to 35°C. Growth of soybean plants at 5°C or 35/25° for 3 weeks had no significant effect on the amount of extractable GR when the developmental decline of enzyme activity is considered. Chilling exposure produced a 4-fold increase in total glutathione in second trifoliolate leaves and a significant decrease in the GSH/GSSG ratio.*

The idea that glutathione and glutathione reductase (GR) (EC 1.6.4.2) are involved in tolerance to or avoidance of biological stress was developed in Levitt's thiol:disulfide hypothesis of frost injury and resistance in plants<sup>1</sup>. According to this hypothesis, frost resistance would result from prevention of thiol oxidation, thiol:disulfide interchange, and formation of intermolecular disulfides. The requirements are: a pool of GSH for the oxidant scavenging or reducing system, an active GR to regenerate GSH, a supply of NADPH, and most importantly, operation of the system at low temperature. A variety of studies have shown that a frequent response to low temperature is an increase in the amount of glutathione and/or GR in leaves. The study of Esterbauer and Grill is representative: they measured an annual fluctuation of glutathione and GR levels in needles of field-grown spruce (*Picea abies* L.), with the maximum amounts of both being present in the winter months. The seasonal variation in GR activity also occurred in 22 other evergreen winter-hardy plants<sup>2</sup> and seasonal variation of glutathione in *Picea abies* L. was recently confirmed by Schupp and Rennenberg<sup>3</sup>.

Because cold-tolerant plants have been used in most studies on the role of glutathione in low temperature stress, our goal is to determine the effects of chilling temperatures on the *in vitro* characteristics of GR and the *in vivo* levels of glutathione and GR of a chill-sensitive plant, soybean (*Glycine max* (L) Merr).

## Effect of temperature on GR *in vitro*

The effect of temperature on GR activity *in vitro* is shown in Fig. 1. Within the range of 5° to 35°, the rate of GSSG reduction increased with a  $Q_{10}$  of approximately 2.

<sup>1</sup> Supported by a grant from the National Science Foundation (DMB 8421065) to I.K. Smith.

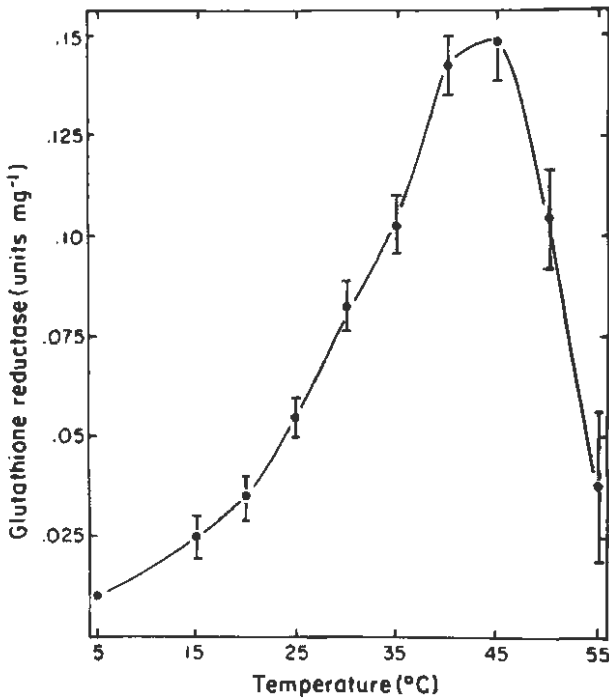

Fig. 1. Effect of assay temperature on soybean GR activity *in vitro*. GR activity was measured in crude tissue homogenates by monitoring the increase in absorbance at 412 nm when DTNB (5,5'-dithiobis-(2-nitrobenzoic acid)) is reduced by GSH<sup>12</sup>. The components of the reaction mixture, 1.1 ml 0.2 M potassium-phosphate buffer (pH 7.5) containing 1 mM EDTA, 0.5 ml 3mM DTNB, 0.1 ml 2 mM NADPH, and 0.1 ml 20 mM GSSG, were mixed in a 4.5 ml cuvette and temperature equilibrated in a Model 900 Isotemp Refrigerated Circulator (Fisher Scientific, Pittsburgh, PA) attached to a spectrophotometer. The reaction was initiated by adding 0.2 ml of plant extract.

These results were obtained using saturating concentrations of NADPH (100  $\mu$ M) and GSSG (1 mM). The effect of temperature at non-saturating concentrations, as indicated by an effect on the apparent  $K_m$ s, is presented in Table 1. The range of  $K_{NADPH}$  and  $K_{GSSG}$  are in general agreement with those obtained by several workers, using a variety of plants<sup>4</sup>. For plants grown at 25°/20°, an increase in assay temperature from 15° to 35° caused a decline in the affinity of the enzyme for both substrates. The effect of temperature on affinity was not as large as that reported by Mahan *et al.*<sup>5</sup>, but was similar to the results of Guy and Carter<sup>6</sup>, who reported that the  $K_{NADPH}$  (8  $\mu$ M) was similar at 5° and 25° and the  $K_{GSSG}$  was 24  $\mu$ M at 5° and 38  $\mu$ M at 25°C, using the enzyme from non-hardened spinach. In cold-hardened spinach, however, the kinetic characteristics were significantly different when the enzyme was assayed at 5° ( $K_{NADPH}$  2  $\mu$ M,  $K_{GSSG}$  5  $\mu$ M) and 25°C ( $K_{NADPH}$  6  $\mu$ M,  $K_{GSSG}$  52  $\mu$ M), and these differences were shown to be due to the synthesis of new isozymes<sup>6</sup>. By contrast, exposure of soybean to 5° for 2 weeks had little effect on the kinetic characteristics of extractable GR (Table 1).



**Table 1.** Effect of temperature on the kinetic constants of soybean GR. Soybean plants were grown on a regime of 12 h light ( $300 \mu\text{E}/\text{m}^2/\text{s}$ ) at  $25^\circ$  and 12 h dark at  $20^\circ\text{C}$  until the second trifoliate leaf was well-developed. Plants were then placed in  $5^\circ\text{C}$  environment with the same photoperiod and light intensity. GR was purified by modifying the protocol of Connell and Mullet<sup>13</sup>. Fifty g of leaf tissue was homogenized in 200 ml of 50 mM Tris/HCl buffer with 2.5 g PVP and 5 mM EDTA. GR was precipitated in the 40-80% fraction of  $(\text{NH}_4)_2\text{SO}_4$ , applied to a DEAE-cellulose column and eluted with a 0.05-0.25 M KCl gradient. GR was further purified with a 5 ml column of ADP-agarose and eluted with NADP. The GSSG concentration was 0.5 mM for the determination of  $K_{\text{NADPH}}$  and 0.1 mM NADPH was used to determine  $K_{\text{GSSG}}$ .

	Assay temperature	$K_{\text{NADPH}}$ $\mu\text{M}$	$K_{\text{GSSG}}$ $\mu\text{M}$
Plants grown at $25/20^\circ\text{C}$	15	2.8	15
	25	3.8	21
	35	4.2	24
Plants grown at $5/5^\circ\text{C}$ for 2 weeks	15	4.0	14
	25	8.4	21
	35	7.5	26

### Effect of chilling on extractable GR activity

In soybean, the amount of extractable GR, on a U/g FW basis, declines as the leaf matures. Growth of plants at  $5^\circ\text{C}$  or  $35^\circ/25^\circ\text{C}$  had no significant effect on the amount of extractable GR, when this developmental decline is taken into consideration (Table 2). This observation contrasts with previous work with spinach, where hardening at  $5^\circ$  for 4 weeks caused a 1.6-fold increase in extractable GR that was correlated with an increase in GSH/GSSG ratio<sup>6</sup>.

### Effect of cold on glutathione levels in soybean leaves

Exposure of soybeans to  $5^\circ\text{C}$  caused an increase in the total glutathione and a decrease in GSH/GSSG ratio, although the exact quantitative levels differed in mature and immature leaves (Table 3). In mature primary leaves the total amount of glutathione increased more than two-fold in the first week, but then remained relatively stable for two weeks during which time the pool of glutathione became progressively more oxidized. Whereas in immature second trifoliate leaves, glutathione continued to accumulate over a three-week period, but again, the GSH/GSSG ratio declined. These results emphasize the importance of determining GSH and GSSG separately in any studies of the effect of stress on glutathione levels: the two-fold increase in total glutathione in primary leaves over a 3 week period, which might superficially be regarded as desirable, is revealed by the GSH/GSSG ratio as indicating extreme stress. The data in Table 3 indicate that at  $5^\circ\text{C}$  the rate of GSH oxidation exceeds the rate of GSSG reduction.

Table 2. Effect of chilling on GR activity in soybean leaves. Leaf tissue was ground with a little sand in a mortar in 10 volumes 0.1 M potassium-phosphate buffer (pH 7.5) containing 0.5 mM EDTA, the brei was filtered through cheese cloth and the filtrate centrifuged at 20,000 g (10 min) to sediment particulate matter. GR was assayed by monitoring the change in absorbance at 412 nm as DTNB is reduced<sup>12</sup>.

Leaf	Conditions		GR U/g FW
	weeks at °C		
Primary	0	5/5	2.2
	1		1.8
	2		1.8
	3		1.8
	0	35/25	2.2
	1		1.8
	2		1.7
	3		--
Second Trifoliolate	0	5/5	2.1
	1		2.2
	2		1.7
	3		1.7
	0	35/25	1.8
	1		2.0
	2		1.5
	3		1.4

Table 3. Effect of cold on glutathione levels in soybean leaves. Glutathione was measured by the coupled GR assay<sup>14</sup>. Plants were grown at 25/20°C until the second trifoliolate leaf was well developed and then transferred to the temperature regime given in the table.

Leaf	Conditions:		nmol/g FW		$\frac{GSH}{GSSG}$	
	Weeks at °C		GSH	GSSG		
Primary	0	5/5	860	10	86	
	1		1880	230	8.2	
	2		1060	590	1.8	
	3		290	1390	0.2	
	0	35/25	930	10	93	
			470	10	47	
	2		390	10	39	
	3		700	10	70	
	Second Trifoliolate	0	5/5	1090	20	55
		1		2690	160	17
		2		2450	760	3.2
		3		2200	2190	1.0
0		35/25	940	10	94	
1			870	10	87	
2			680	10	68	
3			900	10	90	

## Discussion

Because the sole function of GR is the reduction of GSSG, we would expect GR localization close to the sites of GSSG production. In peas, two-thirds of the enzyme is localized in the chloroplast and a third is extrachloroplastic<sup>7,8</sup>. Previous estimates of chloroplastic and cytoplasmic glutathione concentrations<sup>7,8,9</sup> and the amounts reported in Table 3 suggest that usually GR would be saturated with GSSG (see  $K_m$  in Table 1). The amount of GR does not appear limiting, in soybean the total activity at 5°C is 0.5 U/g FW or 500 nmol/min/g FW (25% of 25°C rate; Table 2). This is enough activity to reduce approximately one-half the glutathione pool in one minute and would appear sufficient unless there is a very high rate of cycling.

If the NADPH concentration in soybean is similar to that in oat mesophyll cells (30  $\mu$ M)<sup>10</sup>, the enzyme would also be saturated by NADPH (see Table 1). However, there is no *a priori* reason for the sites of NADPH production and glutathione oxidation to correspond, because of the multiple uses of NADPH in plant metabolism, nor can it be assumed that plants grown at 5°C have the same ability to generate NADPH as do plants grown at 25°C. We conclude that the accumulation of GSSG at chilling temperature is primarily due to an inadequate supply of NADPH to enzyme; Burke and Hatfield<sup>11</sup> also concluded that when winter wheat (*Triticum aestivum* L. var Kanking) is stressed due to water deficits the NADPH concentration may be limiting.

Experiments are in progress to determine NADPH concentrations of chilled and non-chilled soybean plants. Additional work to determine glutathione levels and GR activity in more chill-tolerant varieties of soybean is also in progress.

## References

1. Levitt, J. 1962. *J. Theoret. Biol.* 3: 355-391.
2. Esterbauer, H. and Grill, D. 1978. *Plant Physiol.* 61: 119-121.
3. Schupp, R. and Rennenberg, H. 1988. *Plant Sci.* 57: 113-117.
4. Kalt-Torres, W., Burke, J.J. and Anderson, J.M. 1984. *Physiol. Plant* 61: 271-278.
5. Mahan, J.R., Burke, J.J. and Orzech, K.A. 1987. *Plant Physiol.* 83: S87.
6. Guy, C.L. and Carter, J.V. 1984. *Cryobiology* 21: 454-464.
7. Bielawski, W. and Joy, K.W. 1986. *Planta* 169: 267-272.
8. Gillham, D.J. and Dodge, A.D. 1986. *Planta* 167: 246-251.
9. Klapheck, S., Latus, C. and Bergmann, L. 1988. *J. Plant Physiol.* 131: 123.
10. Hampp, R., Goller, M., and Fullgraf, H. 1984. *Plant Physiol.* 75: 1017-1021.
11. Burke, J.J. and Hatfield, J.L. 1987. *Plant Physiol.* 85: 100-103.
12. Smith, I.K., Vierheller, T.L. and Thorne, C.A. 1988. *Anal. Biochem.* 175: 408-413.
13. Connel, J.P. and Mullet, J.E. 1986. *Plant Physiol.* 82: 351-356.
14. Smith, I.K. 1985. *Plant Physiol.* 79: 1044-1047.

## **ACKNOWLEDGEMENTS**

### **Reviewers of the contributions published in this volume**

J.W. Anderson, Bundoora, Australia  
J.N.B. Bell, Ascot, U.K.  
C. Brunold, Bern, Switzerland  
A.A. Benson, La Jolla, U.S.A.  
E. Heinz, Hamburg, F.R.G.  
P.J. Jackson, Los Alamos, U.S.A.  
P. Macnicol, Canberra, Australia  
J.T. Madison, Ithaca, U.S.A.  
P. Nissen, Bergen, Norway  
P.J. Randall, Canberra, Australia  
W. Rauser, Guelph, Canada  
H.M. Reisenauer, Davis, U.S.A.  
V.V. Rendig, Davis, U.S.A.  
H. Rennenberg, Garmisch-Partenkirchen, F.R.G.  
J.A. Schiff, Waltham, U.S.A.  
J.D. Schwenn, Bochum, F.R.G.  
J. Sekiya, Tsushima, Japan  
G. Tamura, Matsudo, Japan  
M. Thellier, Mont-Saint-Aignan, France  
K. Winter, Würzburg, F.R.G.  
H. Ziegler, München, F.R.G.

### **Index**

W. Bosma, Haren, The Netherlands

### **The organizing committee of the workshop**

C. Brunold  
L.J. De Kok  
P.J.C. Kuiper  
H. Rennenberg  
I. Stulen

### **Organizations which sponsored the workshop**

Fraunhofer Institute for Atmospheric Environmental Research  
HoekLoos Speciale Gassen, Schiedam, The Netherlands  
Royal Netherlands Academy of Arts and Science  
Swiss National Academy of Science  
University of Groningen, Faculty of Science  
University of Groningen Fund



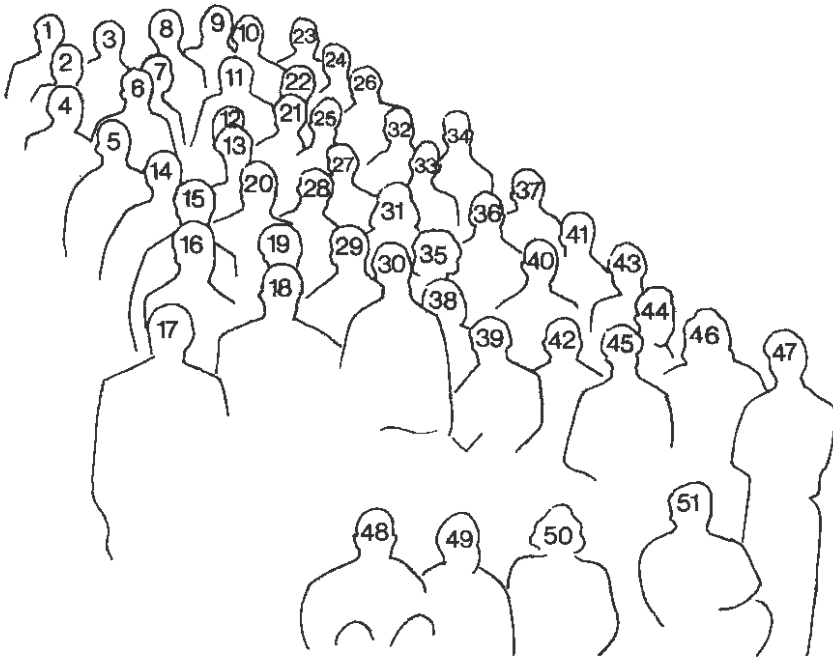

1 J.A. de Knegt; 2 U. Pieper; 3 F.-A. Krone; 4 N.J. Robinson; 5 J. Giovanelli; 6 P.B. Goldsbrough; 7 C.E.E. Stuiver; 8 K. Nagel; 9 M. Droux; 10 M.H. Zenk; 11 P.J.C. Kuiper; 12 R. Kneer; 13 F. Buwalda; 14 A. Schmidt; 15 D. Schmutz; 16 D. Grill; 17 P. Schröder; 18 H. Rennenberg; 19 A. Egger; 20 C. Brunold; 21 S. Klapheck; 22 L. Bergmann; 23 J.F. Thompson; 24 A. Schneider; 25 W.J. Cram; 26 E. Schnug; 27 I.K. Smith; 28 H. Pfanz; 29 S. Farago; 30 R. Schupp; 31 B. Huber; 32 M. Kreis; 33 K.E. Palletti; 34 T. Vierheller; 35 C. Herschbach; 36 J.A.C. Verkleij; 37 P.J. Lea; 38 R. Alscher; 39 I. Stulen; 40 J. Hayes; 41 W.H.O. Ernst; 42 C. Passera; 43 K.-J. Dietz; 44 C.I. Bell; 45 K.-C. Lakkineni; 46 L.J. De Kok; 47 W. Bosma; 48 G.L. Lamoureux; 49 A. Polle; 50 K.F. Kleppinger-Sparace; 51 G.P. Telkamp

## INDEX OF AUTHORS

- Abrol, Y.P., 213  
Alscher, R.G., 195  
Bell, C.L., 163  
Berger, J.M., 235  
Bergmann, L., 167  
Bermadinger, E., 191  
Bosma, W., 173  
Bottacin, A., 181  
Brunold, C., 13, 241  
Busch, H., 177  
Cacco, G., 181  
Clarkson, D.T., 163  
Cosse, H., 199  
Cram, W.J., 3, 163  
De Knecht, J.A., 255  
De Kok, L.J., 111, 173  
Delhaize, E., 235  
Dietz, K.-J., 177, 229  
Ernst, W.H.O., 131, 255  
Ferrari, G., 181  
Fuerst, E.P., 217  
Giovannelli, J., 33  
Goldsbrough, P.B., 185  
Grill, E., 89  
Grill, D., 191  
Gupta, S.C., 185  
Gupta, A.S., 195  
Guttenberger, H., 191  
Hell, R., 167  
Jackson, P.J., 235  
Kamminga, G., 173  
Klapheck, S., 199  
Kleppinger-Sparace, K.F., 77, 205  
Koevoets, P.L.M., 255  
Kreis, M., 67  
Krone, F.A., 209  
Lakkineni, K.C., 213  
Lamoureux, G.L., 53, 217, 245  
Lindsay, W.P., 235  
Madison, J.T., 145  
McCune, D.C., 195  
Mendum, M.L., 185  
Mudd, J.B., 77, 205  
Mundt, C., 209  
Nagel, K., 223  
Nair, T.V.R., 213  
Oppmann, B., 229  
Pfanzen, H., 229  
Rennenberg, H., 53, 249  
Robinson, N.J., 235  
Rüegsegger, A., 241 Rusness, D.G.,  
217, 245  
Saccomani, M., 181  
Schmutz, D., 241  
Schnug, E., 97  
Schröder, P., 245  
Schupp, R., 249  
Schwenn, J.D., 209  
Smith, I.K., 261  
Sparace, S.A., 77, 205  
Thompson, J.F., 145  
Van 't Riet, J., 255  
Verkleij, J.A.C., 255  
Vierheller, T.L., 261  
Weinerth, I., 229  
Winnacker, E.-L., 89  
Zenk, M.H., 89  
Zimmer, I., 199

# INDEX

- abscisic acid, 152, 153, 155, 160  
*Acer*, 92  
acetate, 205-208  
acetyl-coenzyme A, 35  
O-acetyl-L-serine, 23, 35, 50, 249-252  
O-acetyl-L-serine sulfhydrylase (EC 4.2.99.8), 21, 23, 38, 116, 118, 209-212  
acetyl-cysteine, 205-208  
adenosine 3'-phosphate 5'-phosphate (PAP), 14  
adenosine 3'-phosphate 5'-phosphosulfate (PAPS), 17, 18, 20, 21  
  role in glucosinolate synthesis, 99  
  role in SQDG synthesis, 79-80, 82  
adenosine 3'-phosphate 5'-phosphosulfate reductase, 18  
  gene of, 209-212  
adenosine 3'-phosphate 5'-phosphosulfate sulfotransferase, 14, 18-19, 21  
adenosine 5'-phosphosulfate (APS), 16-17, 20-21, 82  
  inhibition of ATP-sulfurylase by, 16, 23  
  role in SQDG-synthesis, 79, 80, 85, 205-208  
  synthesis, 14-16  
adenosine 5'-phosphosulfate kinase (EC 2.7.1.25), 16-17, 209-212  
adenosine 5'-phosphosulfate sulfotransferase, x, 14, 17-18, 209-212, 249-253  
effects of cadmium on, 93, 235-240, 241-243  
  localization, 20-21  
  regulation, 23-25  
adenosine 5'-triphosphate sulfurylase (EC 2.7.7.4), 14-16, 209-212  
effects of cadmium on, 93, 235-240, 241-243  
  localization, 20-22  
  reaction with sulfate analogues, 16  
  regulation, x, 23-25  
S-adenosylmethionine (AdoMet), 36, 38-40, 42, 45, 151  
adenyl imidodiphosphate, 180  
*Adiantum*, 132  
*Aerobacter*, x  
*Agriolimax*, 137  
*Agrostis*, 255-260  
*Akaniaceae*, 98  
albumin, 67, 71, 73, 147-148  
S-alkylcysteine sulfoxides, 3  
*Allium*, 62, 135-137, 139  
allyl-isothiocyanate, 136-137  
allyl-nitrile, 137  
*Alyssum*, 138  
*Amaryllidaceae*, 136  
 $\alpha$ -amino-butyrate, 55, 168  
aminotriazol, 199-203  
amylase inhibitors, 68  
*Ananas*, 45  
*Anthriscus*, 131  
*Arachis*, 79, 82, 213-216, 245-248  
*Arion*, 137  
*Armeria*, 133  
ascorbate, 195-197, 199-203, 205-208, 229-233  
ascorbate peroxidase, 199-203  
*Asparagus*, 181-183  
aspartate, 41, 42, 44  
aspartic semialdehyde, 42  
aspartic semialdehyde dehydrogenase (EC 1.2.1.11), 42  
aspartokinase (EC 2.7.2.4), 38, 40-46  
aspartyl phosphate, 42, 46  
*Asterius*, 84  
ATP sulfurylase, see adenosine 5'-triphosphate sulfurylase  
atrazine, 60, 217-221, 245-248  
*Avena*, 67, 261-265  
*Baccillariophyta*, 83  
*Bataceae*, 98  
*Bertholletia*, 69, 71-73, 154  
*Beta vulgaris*, 83, 173-175  
bicarbonate, 205-208  
bisulfate, 205-208  
boron, 101  
Bowman-Birk protease inhibitor, 70, 153-154  
*Brassica*, 16, 71-72, 98, 100-103, 136-137, 159-160, 209-212, 213-216, 255-260  
*Brassicaceae*, 97-98, 136, 138-139  
*Bretschneideraceae*, 98  
*Bryophyta*, 90, 93  
buthionine sulfoximine (BSO), 55, 91-92, 119, 154, 185-189, 235-240  
cadmium, 25, 89-93, 138, 185-189, 223-227, 235-240, 241-243, 255-260  
cadystin, 91, 235-240, 241-243  
*Candida*, 91, 167-171  
*Capnocytophaga*, 84  
*Capparaceae*, 98, 136, 159  
carbonyl sulfide, 113  
*Cardamine*, 137  
*Caricaceae*, 98, 136  
carrier-thiol, 17-18  
catalase (EC 1.11.1.6), 199-203, 229-233  
*Ceterach*, 132  
*Cetraria*, 191-193  
*Chara*, 5  
*Chlamydomonas*, 17, 79, 223-227  
*Chlorella*, 5, 17, 18, 20, 34, 79, 85  
chloroacetamide herbicides, 217-221  
1-chloro-2,4-dinitrobenzene (CDNB), 245-248



- coenzyme-A, 53, 205-208  
*Coix lachryma-jobi*, 70  
 conglutin, 146  
   subunits of, 146, 148, 150-153, 155  
 conglycinin, 145-155  
 copper, 89-93, 138, 235-240, 255-260  
*Cruciferae*, 62, 133, 159  
*Cucumis*, 134  
*Cucurbita*, 35, 59, 134  
*Cucurbitaceae*, 121  
 $\beta$ -cyanoalanine synthase (EC 4.4.1.9), 213-216  
*Cyanobacteria*, 17-18  
 cycloheximide, 92, 235-240  
 $\beta$ -cystathionase (EC 4.4.1.8), 38  
 cystathionine, 37  
 cystathionine  $\gamma$ -synthase, 37-40, 45  
 cysteic acid, 79  
 cysteine  
   accumulation, 115-116, 118-121, 173-175, 249-253  
   concentration, 34-36, 50, 119-120  
   conjugation with herbicides, 245-248  
   content in seed proteins, 68-69, 71-72  
   desulfhydration, 117, 120-121, 213-216  
   determination, 19  
   direct incorporation of H<sub>2</sub>S into, 115  
   diurnal changes, 249-253  
   effects on sulfate fluxes, 7  
   effects of S-deficiency on, 146-147  
   occurrence in eukaryotes, 53  
   role in glucosinolate synthesis, 99  
   role in regulation of APS-sulfotransferase, 23, 118  
   role in sulfolipid synthesis, x, 79, 205-208  
   role in synthesis of  $\gamma$ -glu-cys, 167-171  
   synthesis, 20-22, 33-35  
   toxicity, 121  
   transport, 115  
 cysteine desulfhydrase (EC 4.4.1.1), 36, 117, 120-121, 213-216  
 cysteine sulfinic acid, x  
 cysteine synthase, see O-acetyl-L-serine sulfhydrylase  
 cysteinylglycine, 56-57, 62  
 cystine, 8, 146-147, 154  
  
*Datura*, 235-240, 255-260  
*Daucus*, 7-8  
 dehydroascorbate reductase, 199-203  
*Delia*, 137  
 1-deoxyceramide-1-sulfonic acid (DCS), 83, 85  
*Desulfotomaculum*, 14  
*Desulfovibrio*, 14  
 diacylglycerol, 80  
 dihydropicolinate, 42  
 dihydropicolinate synthase (EC 4.2.1.52), 41  
 dimethyl sulfide (DMS), 133-136, 139, 159  
 dimethylsulfoniopropionate (DMSP), 132, 134-135  
 dithioerythritol (DTE), 56, 167  
 dithiothreitol (DTT), 17, 205-208, 249-253  
 DNA binding protein, 153  
  
*Entamoeba*, 53  
*Enteromorpha*, 134  
*Erythrina*, 82  
*Escherichia*, 18, 53, 209-212  
 S-ethylcysteine, 152  
 ethylene, 160  
*Euglena*, ix-xi, 17, 22, 78-79, 85  
*Euglenophyceae*, 83  
*Euglenophyta*, 78  
*Euphorbiaceae*, 98  
  
*Fabaceae*, 90  
*Fabales*, 90  
*Fagus*, 24, 118  
 flavonoid-sulfate, 84-85, 132-133, 139, 159  
 fluorodifen, 245-248  
 3-fluoropyruvate, 35  
 foxtail, 217-221  
*Frankenia*, 133  
 fusicoccin, 5  
  
*Geranium*, 117  
 globulins, 67, 145, 147-149  
 glucosides, cyanogenic-, 159  
 glucosinolates, 97-106, 132, 136-138, 159  
 $\gamma$ -glutamyl- $\alpha$ -aminobutyrate, 56, 167-171  
 $\gamma$ -glutamyl cycle, 57  
 $\gamma$ -glutamyl cyclotransferase (EC 2.3.2.4), 56-58  
 $\gamma$ -glutamylcysteine  
   accumulation, 115-116, 118-120, 249-253  
   conjugates, 62, 245-248  
   diurnal changes, 249-253  
   glutathione metabolism, 51, 55-57  
   phytochelatin synthesis, 92, 185-189, 235-240  
   synthesis, 167-171  
 $\gamma$ -glutamylcysteine synthetase (EC 6.3.2.2), 55, 119, 167-171, 185-189, 235-240  
 $\gamma$ -glutamylcysteinylglycine, see glutathione  
 $\gamma$ -glutamylcysteinyl- $\beta$ -alanine, see homogluta-thione  
 $\gamma$ -glutamyl transpeptidase (EC 2.3.2.2), 56-57  
 glutathione, reduced (GSH)  
   accumulation, 115-116, 118-120, 173-175, 249-253  
   carrier-thiol, 17  
   chloroplast concentration, 20, 54

- conjugates, 57, 60-62, 107, 217-221, 245-248  
content in germinating seed, 199-203  
degradation, 56-58, 249-253  
distribution, 53-55, 119  
diurnal changes, 249-253  
effects of chilling on, 261-265  
effects of heavy metals on, 185-189  
effects of ozone on, 195-197  
effects on protease inhibitor, 154  
inhibition of  $\gamma$ -glu-cys synthetase by, 167-171  
reduced/oxidized ratio 261-265  
regulation of sulfate metabolism by, 8, 49, 59-60, 117-118  
role as anti-oxidant, 195-197  
role as sulfur source, 56, 58  
role in sulfur storage, 36, 59,  
role during frost/photo-oxidation, 191-193  
role in phytochelatin synthesis, 91-92, 185-189, 235-240, 241-243  
seasonal changes, 55, 249-253  
synthesis, 55-56, 167-171  
transport, 9-10, 49, 56, 58-60, 107, 115-116, 249-253
- glutathione, oxidized (GSSG), 120  
effects of ozone on, 195-197  
function, 54, 261-265  
reduction, 249-253, 261-265  
transport, 58
- glutathione reductase (EC 1.6.4.2), 54, 59, 116, 199-203, 261-265
- glutathione-S-transferase (EC 2.5.1.18), 60-61, 107, 245-248
- glutathione synthetase (EC 6.3.2.3), 55-56, 119, 167-171, 261-265
- glutathionyl-polyamines, 60
- glutelin, 67
- glutinin, 146
- glycerol-3-P, 205-208
- glycerolipid, 78, 80, 84, 205-208
- glycine, 119  
*Glycine*, 21, 70, 117, 134, 145-158, 217-221, 261-265
- glycinin, 146, 148-150, 155
- glycophytes, 132
- glycosides, cyanogenic-, 159  
*Gossypium*, 134  
*Gramineae*, 67  
gypsophilous, 132  
*Gyrostemonaceae*, 98
- halophytes, 132-133
- heavy metals, 21, 89-96, 138 (see also cadmium, copper, zinc)  
*Helianthus*, 9, 71-73
- herbicides, 217-221  
antidotes/safeners, 60-62, 217-221
- homocysteine, 33, 36
- homoglutathione, 54, 56, 59  
conjugates, 217-221
- homoglutathione synthetase, 56
- homophytochelatin, 91-93
- homoserine dehydrogenase (EC 1.1.1.3), 39-41, 45
- homoserine kinase (EC 2.7.1.39), 45
- hordein, 70, 72-73  
*Hordeum*, 43, 67, 69-70, 108, 177-180, 229-233
- hydrogen sulfide  
atmospheric concentrations, 112, 136, 173-175  
deposition velocity, 113, 116  
effects on growth, 121  
effects on thiol content, 115-116, 118-120, 173-175  
effects on sulfate content, 114-115  
effects on sulfate reduction, 23-24, 118  
effects on sulfate uptake, 117  
emission, 10, 22-23, 35-36, 116-117, 120-121, 133-135, 139, 213-216, 249-253  
flux, 113, 116  
phytotoxicity, 120-121
- hydrogen peroxide, 199-203, 229-233
- hydrogen peroxide scavenging cycle, 195-197, 199-203
- indolglucosinolates, 101
- Ipomea*, 24
- isocitrate lyase (EC 4.1.3.1), 199-203
- isoleucine, 39, 41, 45-46
- isothiocyanate, 3, 100, 136
- Launea*, 132
- lead, 89, 90
- legumin, 147-148, 150
- Lemna*, 5, 9, 24, 36-39, 41-43, 45, 117, 134, 160
- Lepidium*, 138
- Leptosphaeria*, 136
- leucine, 73, 177-180, 235-240
- lichens, 191-193
- Limnanthaceae*, 98, 136
- Limonium*, 133
- lipoic acid, 205-208
- Lupinus*, 146, 150
- Lycopersicon*, 55, 91-92, 167-171, 185-189, 235-240, 241-243, 255-260
- lysine, 39-46
- Macroptilium* 9, 163-165
- malonylcysteine, 62
- Medicago*, 82

- Megilothus*, 137  
 mercaptoethanol, 167-171  
 mercury, 89-90  
 metal-binding peptides, 235-240 (see also phytochelatins)  
 metallophytes, 138  
 metallothioneins, 90-91, 93, 185-189, 223-227, 235-240, 255-260  
 metazachlor, 217-221  
 methionine, 33, 120  
   biosynthesis, 36-46  
   effect of sulfur nutrition, 120, 146-147  
   effect on gene expression, 147-151  
   effect on proteins, 69-70, 149-155, 177-180  
   effect on sulfate fluxes, 7  
   intracellular compartmentation, 177-180  
   role in glucosinolate synthesis, 99  
   transport across the tonoplast, 177-180  
 methionine-S-sulfoximine, 55  
 24-methylene cholesterol sulfate (MCS), 83-84  
 S-methyl-cysteine-sulfoxide, 101  
 3-methylthiopropionate, 45  
 methylviologen, 20  
 metolachlor, 217-221  
*Mimosaceae*, 136  
 molybdate, 7, 16, 78, 84, 205-208  
 monodehydroascorbate reductase, 199-203  
 monogalactosyldiacylglycerol (MGDG), 80  
*Moricandia*, 132  
*Moringaceae*, 98, 136  
*Mycophyta*, 91, 93  
 myrosinase, 97, 100-101, 103  
  
*Neurospora*, 90  
 nickel, 89, 138  
*Nicotiana*, 8, 23-24, 36, 50, 55-59, 107, 117, 154, 167-171, 209-212, 235-240, 255-260  
 nitrate reductase (EC 1.6.6.1), 21, 25  
   effect of cadmium, 241-243  
 nitrile, 136  
 nitrite reductase (EC 1.7.7.1), 21-22  
 nitrite reduction, 19  
 nitrogen/sulfur metabolism, coupling between, 8-9, 24-25, 35  
 nitrogen/sulfur ratio, 3, 8-10, 111, 131, 146, 160  
*Nitischia*, 84  
  
*Oenothera*, 83  
*Oryza*, 67  
 5-oxo-prolinase (EC 3.5.2.9), 57, 58  
 5-oxo-proline, 57  
 ozone, detoxification, 195-197  
  
 PAP, see adenosine 3'-phosphate 5'-phosphate  
 PAPS, see adenosine 3'-phosphate  
  
   5'-phosphosulfate  
*Penicillium*, 4  
 pentachloronitrobenzene (PCNB), 245-248  
*Pentadiplandraceae*, 98  
*Peronospora*, 136  
 peroxidase (EC 1.11.1.7), 229-233  
 pesticides, conjugation with GSH, 60  
*Petunia*, 152, 154  
*Phaeophyta*, 83  
 phaseolin, 146  
*Phaseolus*, 23-24, 35, 82, 146, 148, 155  
 phaseothione, 53  
 phenol sulfotransferase (EC 2.8.2.1), 133  
 phosphatidylcholine (PC), 84, 92  
 phosphatidylsulfocholine (PSC), 83-85  
 O-phosphohomoserine, 39-40, 45  
 photosynthesis, 195-197, 223-227  
*Phycophyta*, 90, 93  
*Phyllotreta*, 137  
 phytochelatins, 60, 89-95  
   heavy metals and, 138, 177-180, 223-227, 235-240, 241-243, 255-260  
   function, 17, 21, 25, 92-93, 255-260  
   sulfate reduction and, 21, 25, 93  
   synthesis, 91-92, 177-180  
*Picea*, 24, 117, 134, 191-193, 229-233, 245-248, 249-253, 261-265  
*Pieris*, 137  
*Pinus*, 134  
*Pisum*, 21, 23, 45, 56, 70-71, 107, 118, 145-148, 150, 167-171, 199-203, 241-243, 261-265  
*Plutella*, 137  
*Polysiphonia*, 134  
*Popular*, 195-197  
 prolamin, 67-70, 72  
 propachlor, 217-221  
 propargylglycine (PAG), 39  
 S-propenylcysteine sulfoxide, 133, 137  
 proteins  
   2S-, 67-73  
   7S-, 67, 145, 150, 155  
   11S-, 67, 146-147  
   storage-, 145-158  
*Pseudovernia*, 191-193  
*Pteridium*, 132  
*Pteridophyta*, 90, 93  
 pyridine nucleotide levels in *Popular*, 195-197  
 pyruvate dehydrogenase complex, 35  
  
*Raphanus*, 45, 102  
*Rauvolfia*, 90-91, 241-243  
*Resedaceae*, 98, 136  
 ribulose-1',5'-bisphosphate carboxylase (EC 4.1.1.39), 24, 177-180  
*Ricinus*, 71-72, 199-203

- Rosa*, 24-25  
*Saccharomyces*, 5, 209-212  
*Salvadoraceae*, 98  
*Scenedesmus*, 80  
*Schizosaccaromyces*, 91, 93, 185-189, 235-240  
*Secale*, 67, 69  
seed proteins, 67-76  
selenium, 89  
selenate, 7, 118  
serine, 35  
serine acetyltransferase (EC 2.3.1.30), 35, 50  
*Silene*, 92, 255-260  
silver, 89-90, 92  
*Sinapsis*, 72, 102, 209-212, 213-216  
*Sorghum*, 62, 217-221, 245-248  
*Spartina*, 132-135, 139  
*Spermatophyta*, 90, 93  
*Spinacia*, ix, 17-21, 23, 55-56, 79, 113-116, 134, 167-171, 173-175, 177-180, 199-203, 223-227, 249-253, 261-265  
*Spirodela*, 134  
sulfate  
  accumulation, 3, 6, 8-9, 36, 114-115, 119-120, 132-133, 139  
  analogues, 7, 16 (see also selenate, molybdate)  
  assimilatory reduction, 13-31  
    effects of cadmium on, 25, 93, 217-221, 235-240, 241-243  
    effects of safeners on, 62  
    effects of sulfur dioxide on, 24, 118  
    interactions with nitrogen assimilation, 8, 24, 35, 50,  
    localization, ix-xi, 4, 20-22, 50, 79, 107  
    regulation of enzymes, 22-25, 49, 118, 163-165, 209-212  
  compartmental analysis, 6, 163-165  
  dissimilatory reduction, 14  
  effect on H<sub>2</sub>S emission, 23, 117, 213-216  
  effect on protease inhibitor, 153  
  fluxes, 4-9, 163-165  
  induced thiol accumulation by, 119  
  metabolic pool kinetics, 7  
  redistribution, 4, 9, 132, 163-165  
  role in glucosinolate synthesis, 99-100  
  role in maintaining osmotic potential, 132  
  role in sulfolipid synthesis, 78, 83, 205-208  
  secretion, 133  
  storage as flavonoid sulfates, 132-133  
  toxicity, 4  
  transport, 4-8, 114-115, 117,  
  uptake, 3-6, 139, 181-183  
  regulation, 7-9, 49, 60, 62, 117  
  vacuolar storage, 8, 120, 132  
  vacuolar turnover, 6, 163-165  
  wet deposition, 160  
  sulfate adenyltransferase (EC 2.7.7.4), 35  
  sulfate transferases, 84  
  sulfatides, 77, 83-84  
  sulfhydryl compounds (thiols),  
    accumulation, 115-116, 117-120, 173-175  
    effects of altitude on, 191-193  
    effects of season on, 191-193  
    effects of stress on, 195-197, 261-265  
    metabolization of accumulated, 120  
    regulation, 120  
    subcellular distribution, 119  
    transport to roots, 120  
  sulfhydryl reagents, 177-180  
  sulfide,  
    acid labile, 93, 255-260  
    carrier bound, 14, 20, 23, 36, 209-212  
    component of phytochelatin complex, 235-240  
    inhibition of sulfite reductase by, 19, 23  
    oxidation, 115-116,  
    reaction with cellular components, 120  
    storage and transport, 93  
    uptake in anoxic environments, 135, 139  
  sulfite,  
    carrier bound, 14, 20, 209-212  
    content and sulfur dioxide, 114, 120-121  
    effects on hydrogen sulfide emission, 117  
    oxidation, 114, 229-233  
    reaction with cellular components, 120  
    reduction, 14, 19-21  
    role in sulfolipid synthesis, x, 78-79, 85, 205-208  
    sulfite reductase (EC 1.8.7.1), 14, 19-21, 23, 25, 118, 209-212  
    nitrite reduction and, 19, 21  
  sulfoacetate, 85  
  sulfoacetaldehyde, 85  
  S-sulfocysteine, x  
  sulfolipids  
    algal-, 83-85  
    capnoid-, 83-84  
    catabolism, 81-82  
    degradation products, 85  
    sulfocholine, 77, 84  
    (glucosyl-3',6'-disulfate)-6-sulfofucosyl diacyl-  
    glycerol (SFDG), 83  
    sulfonoquinovosyldiacylglycerol (SQDG), 77-  
    83, 85, 205-208  
    synthesis, ix-x, 24, 77-81, 83-84  
  sulfonated flavonoids, 85  
  sulfotransferase, effect of zinc, 138  
  sulfur  
    atmospheric deposition as sulfur source, 4, 112, 159-160  
    content, 111, 131-132

- deficiency, 4, 7, 9, 24-25, 102-103, 111, 146-149, 155  
 elemental-, 82-83, 205-208  
 emission of biogenic, 133-136  
 function in plants, 132  
 nutritional status, 131  
 requirements, 111-112  
 sulfur amino acids, 33, 145, 155, 213-216  
 sulfur compounds,  
   attractants for insects, 101, 137  
   repellants against herbivores, 101, 136-138  
   transport, 9-10  
 sulfur dioxide,  
   atmospheric concentration, 112  
   deposition, 112, 160  
   deposition velocity, 112-113  
   detoxification, 121, 229-223  
   effects on growth, 120-121  
   effects on sulfate accumulation, 114, 119-121  
   effects on sulfate reduction, 24, 118  
   effects on sulfate uptake, 117  
   effects on sulfhydryl content, 115, 119-120  
   phytotoxicity, 120-121  
   re-emission as H<sub>2</sub>S, 116-117  
   uptake, 4  
 sulfur-rich seed proteins, 53-65  
 sulfurous acid, oxidation, 229-233  
 superoxide dismutase (EC 1.15.1.1), 195-197, 199-203, 229-233  
*Synechococcus*, 209-212  
  
*Tamarix*, 133  
 thiocarbamate herbicides, 218  
 thiocyanate, 136  
 thioglucosid glucohydrolase (myrosinase, EC 3.2.3.1), 97, 100, 103, 136  
 thioglucosides, sulfated-, 133  
 thioredoxin, 14, 17-19, 21, 209-212  
 thiosulfate, 205-208  
 thiosulfate reductase (EC 2.8.1.3), 14, 19-20, 25, 209-212, 225-240  
 thiosulfonate reductase, see thiosulfate reductase  
*Thlaspi*, 138  
 threonine, 39-45  
 threonine dehydratase (EC 4.2.1.16), 39, 41  
 threonine synthase (EC 4.2.99.2), 39, 45  
*Tovariaceae*, 98  
 tridiphane, 217-221  
*Trifolium*, 173-175  
*Triticum*, 24, 67, 69, 163-165, 167-171, 213-216, 261-265  
*Tropaeolaceae*, 98, 136  
 trypsin inhibitor, 70, 72-73  
 tyrosine-O-sulfate, x  
 UDP-galactose, 80  
 UDP-sulfoquinovose, 78, 80, 85  
  
 vicilin, 145-148, 150  
*Vigna*, 59  
  
 xenobiotics, 54, 60, 245-248  
  
 yeast (see also *Saccharomyces* and *Schizosaccharomyces*) 18, 90, 241-243  
  
*Zea*, 21, 23, 25, 49, 55, 60-62, 67-69, 71, 91, 93, 199-203, 217-221, 241-243, 245-248  
 zeins, 67, 69-72  
 zinc, 89-90, 92-93, 138, 255-260  
*Zostera*, 132, 134