

University of Groningen

Supramolecular Complexes from CdSe Nanocrystals and Organic Fluorophors

Schmelz, Oliver; Mews, Alf; Basché, Thomas; Herrmann, Andreas; Müllen, Klaus

Published in:
Langmuir

IMPORTANT NOTE: You are advised to consult the publisher's version (publisher's PDF) if you wish to cite from it. Please check the document version below.

Document Version
Publisher's PDF, also known as Version of record

Publication date:
2001

[Link to publication in University of Groningen/UMCG research database](#)

Citation for published version (APA):
Schmelz, O., Mews, A., Basché, T., Herrmann, A., & Müllen, K. (2001). Supramolecular Complexes from CdSe Nanocrystals and Organic Fluorophors. *Langmuir*, 17(9), 2861-2865.

Copyright
Other than for strictly personal use, it is not permitted to download or to forward/distribute the text or part of it without the consent of the author(s) and/or copyright holder(s), unless the work is under an open content license (like Creative Commons).

The publication may also be distributed here under the terms of Article 25fa of the Dutch Copyright Act, indicated by the "Taverne" license. More information can be found on the University of Groningen website: <https://www.rug.nl/library/open-access/self-archiving-pure/taverne-amendment>.

Take-down policy
If you believe that this document breaches copyright please contact us providing details, and we will remove access to the work immediately and investigate your claim.

Downloaded from the University of Groningen/UMCG research database (Pure). <http://www.rug.nl/research/portal>. For technical reasons the number of authors shown on this cover page is limited to 10 maximum.

Supramolecular Complexes from CdSe Nanocrystals and Organic Fluorophors

Oliver Schmelz,[†] Alf Mews,^{*,†} Thomas Basché,[†] Andreas Herrmann,[‡] and Klaus Müllen[‡]

Institut für Physikalische Chemie, Welderweg 11, 55099 Mainz, Germany, and Max-Planck-Institut für Polymerforschung, Ackermannweg 1, 55128 Mainz, Germany

Received November 27, 2000. In Final Form: February 14, 2001

Heterosupramolecular structures from CdSe or CdSe/ZnS core/shell nanocrystals and a specially designed organic fluorophore (diazaperylene) have been prepared to investigate the electronic interactions at nanoscopic semiconductor surfaces. To determine the average number of dye molecules per nanocrystal, we monitored the size-dependent molar extinction coefficient of CdSe particles. The NC/dye ratio is depending on the particle size and varies between 3 and 20 dye molecules per nanocrystal. We demonstrate that the fluorescence of the nanocrystals is completely quenched upon the formation of the supramolecular NC/dye complex even if the surface of the CdSe particles is covered with a few monolayers of the high band gap semiconductor ZnS.

Introduction

The use of semiconductor nanocrystals (NCs) in nanotechnology strongly depends on the ability to attach these particles to specific locations of potential devices. Colloidal particles prepared by wet chemical methods provide this flexibility because they are covered with molecular ligands. The ligands can serve as molecular wires as has been shown for nanocrystals bound between nanoelectrodes via bifunctional dithiols where single-electron charging effects could be observed.^{1,2} Another interesting application of semiconductor nanocrystals is their use in biolabeling. It was demonstrated that the particles can be attached to appropriate binding sites in biological systems where the size-dependent color variation of the NCs was used for multicolor fluorescence imaging.³ However, the nature of the ligands can influence the photophysics of the particles tremendously.⁴ Especially the nanocrystal fluorescence can be quenched because certain ligands may serve as scavengers for the photogenerated charge carriers. Therefore inorganic surface passivation, i.e., overcoating of the particles with a material of higher band gap, has been utilized.⁵ In the overcoated particles the charge carriers are mainly localized in the core which increases the fluorescence quantum yield to more than 50%.^{6,7} In the present work we investigate the electronic interaction of the overcoated particles with their molecular surface ligands in detail. To monitor the electronic properties of the particles and the ligands by fluorescence measurements, we have used a new kind of dye molecule as a

functional ligand. The specially designed diazaperylene dye is a perylene derivative with two nitrogen atoms at one of the bay areas which serve as specific binding sites to the nanocrystal surface. The NC/dye ratio was determined from the size-dependent molar extinction coefficient of the nanocrystals. These “heterosupramolecular” complexes⁸ are considered to be prototype structures for electronic interactions at nanoscopic semiconductor surfaces the understanding of which is of great interest for, e.g., photovoltaic devices based on nanoparticles.^{9–11}

Results

In the last years CdSe particles have become a model system in nanocrystal research because their band gap can be tuned over almost the whole visible range and the particles can be synthesized with a remarkable size control and very high crystallinity.¹² The upper part of Figure 1 shows absorption spectra of CdSe particles of different sizes which were prepared via high-temperature organometallic chemistry.^{13,14} Briefly, a solution of dimethylcadmium and selenium powder in tributylphosphine (TBP) was injected in hot trioctylphosphine oxide (TOPO) ($T > 300^\circ\text{C}$) whereby the desired particle size was achieved by varying the temperature, the concentration of reactants, and the reaction time. The overcoating of the particles with ZnS was performed according to ref 15; i.e., CdSe particles were dissolved in molten TOPO and the ZnS shell was grown by addition of diethylzinc and hexamethyldisilathiane ((TMS)₂S).

To use these particles as chemical precursors to build up more complex structures, like NC/dye composites, the particle concentration in solution needs to be known. In general, the concentration could be determined very easily

* To whom correspondence may be addressed. Phone: ++ 49 6131 3922982. Fax: ++ 49 6131 3923953. E-mail: alf.mews@uni-mainz.de.

[†] Institut für Physikalische Chemie.

[‡] Max-Planck-Institut für Polymerforschung.

(1) Klein, D. L.; Roth, R.; Lim, A. K. L.; Alivisatos, A. P.; M€uen, P. L. *Nature* **1997**, *389*, 699.

(2) Banin, U.; Cao, Y. W.; Katz, D.; Mill€o, O. *Nature* **1999**, *400*, 542.

(3) Bruchez, M.; Maronne, M.; Gin, P.; Weiss, S.; Alivisatos, A. P. *Science* **1998**, *281*, 2013.

(4) Kuno, M.; Lee, J. K.; Dabbousi, B. O.; Mikulec, F. V.; Bawendi, M. G. *J. Chem. Phys.* **1997**, *106*, 9869.

(5) H€asselbarth, A.; Eychm€uller, A.; Eichberger, R.; Giersig, M.; Mews, A.; Weller, H. *J. Phys. Chem.* **1993**, *97*, 5333.

(6) Hines, M. A.; Guyot-Sionnest, P. *J. Phys. Chem.* **1996**, *100*, 468.

(7) Peng, X. G.; Schlamp, M. C.; Kadavanich, A. V.; Alivisatos, A. P. *J. Am. Chem. Soc.* **1997**, *119*, 7019.

(8) Cusack, L.; Rao, N.; Fitzmaurice, D. *Chem. Eur. J.* **1997**, *3*, 202.

(9) O'Regan, B.; Grätzel, M. *Nature* **1991**, *353*, 737.

(10) Vogel, R.; Pohl, K.; Weller, H. *Chem. Phys. Lett.* **1990**, *174*, 241.

(11) Ginger, D. S.; Greenham, N. *Phys. Rev. B* **1999**, *59*, 10622.

(12) Alivisatos, A. P. *J. Phys. Chem.* **1996**, *100*, 13226.

(13) Murray, C. B.; Norris, D. J.; Bawendi, M. G. *J. Am. Chem. Soc.* **1993**, *115*, 8706.

(14) Bowen Katari, J. E.; Colvin, V. L.; Alivisatos, A. P. *J. Phys. Chem.* **1994**, *98*, 4190.

(15) Daboussi, B. O.; Rodriguez-Veijo, J.; Mikulec, F. V.; Heine, J. R.; Matcossi, H.; Ober, R.; Jensen, K. F.; Bawendi, M. G. *J. Phys. Chem. B* **1997**, *101*, 9436.

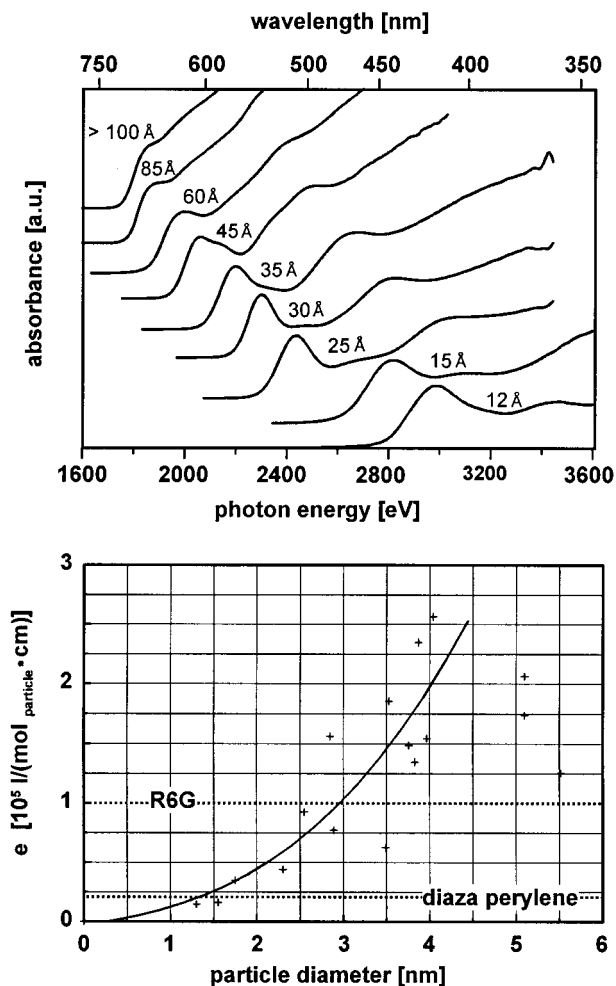

Figure 1. The upper graph shows a set of CdSe nanocrystals in a size regime of 1–10 nm in diameter. The lower graph shows their molar extinction coefficients at their first absorption maximum. Particles 3 nm in diameter (250 CdSe units) have the same extinction coefficient as R6G. The molar extinction coefficient of the diazaperylene is 1.8×10^4 L/(mol cm). Deviation from the cubic dependence of the absorption coefficient upon particle diameter (solid line) may be due to different size distribution or overlapping absorption bands.

by optical absorption measurements if their molar extinction coefficient would be known. Although CdSe nanocrystals were investigated in detail in the past few years, very little is known about their absorption strength. Therefore, we synthesized a set of CdSe particles and determined the molar extinction coefficient at their first absorption maximum, i.e., at their “excitonic” or “band gap” absorption. The total cadmium concentration of each sample was determined by atomic absorption spectroscopy (AAS) after digesting the particles in HNO_3 . The particle concentration was then calculated by assuming bulk lattice parameters and spherical symmetry where the particle diameter was deduced from the absorption spectra. The correspondence of particle diameter and absorption spectra was taken from the literature.^{13,14} The lower graph in Figure 1 shows the dependence of the absorption coefficient upon particle diameter. Even though there is a fairly large dispersion in the data, which is due to several experimental uncertainties such as variation in size and shape, it can be seen that the trend follows a cubic dependence (solid line) up to a diameter of approximately 4.5 nm; i.e., it appears to scale with the volume of the particles. This observation shows that the absorption coefficient is proportional to the number of CdSe units in the nano-

crystal. In contrast, measurements on colloidal CdS particles prepared in aqueous solution showed that the oscillator strength is not depending on particle diameter if the size of the nanocrystals is smaller than the bulk exciton.¹⁶ Above a diameter of approximately 5 nm the absorption peaks cannot be clearly resolved in the spectra (see upper part of Figure 1). Also even slight variations in size can already lead to a large divergence in molecular weight. Therefore, we found that a reliable estimate of the molar extinction coefficient on the basis of ensemble absorption spectra can only be given up to a diameter of 5 nm for CdSe nanocrystals prepared by the described method. By comparison of the absorption strength to those of common dye molecules, we have found that CdSe particles of 3 nm diameter containing about 250 CdSe units have approximately the same molar extinction coefficient as Rhodamine 6G (1×10^5 L/(mol cm)) at the first absorption maximum. The diazaperylene dye which is eventually attached to the nanocrystal surface (see below) has a molar extinction coefficient of 1.8×10^4 L/(mol cm), i.e., comparable to particles with a diameter of 1.5 nm. Therefore, the determination of the size-dependent extinction coefficient allows for a profound estimation of the NC/dye ratio in the composite structures.

The formation of the NC/dye composites occurs via a ligand exchange reaction. As mentioned above the synthesis of the particles proceeds in TOPO where the oxygen is attached to the surface and the long alkyl chains provide solubility in nonpolar solvents such as toluene or hexane. Polar solvents such as methanol or ethanol cause precipitation of the particles from solution.¹³ We have investigated a large number of nitrogen-containing ligands such as aniline, benzylamine, phenylethylamine, dodecylamine, pyridine, and phenazin compounds. For macroscopic CdSe surfaces, it was shown that TOPO and amine ligands are not strongly bound to the surface but that there is a dynamic exchange equilibrium between attached ligands and ligands in solution.^{17,18} For the CdSe nanocrystals we found that this equilibrium is depending not only on the ligand itself but also on parameters such as particle size, solvent, temperature, and concentrations. To investigate the affinity of different amines to the nanocrystal surface, the TOPO ligands were first exchanged by pyridine. This was done by subsequently refluxing the particles in pyridine and precipitation through addition of hexane for several times. The pyridine on the surface of the particles was then exchanged by addition of different amines as could be monitored by NMR spectroscopy. As a general trend in binding strength among the investigated amines, it can be claimed that aromatic amines are less strongly bound to the surface than aliphatic amines where the binding strength increases with the aliphatic chain length. The strongest bonds, however, were formed with bidental ligands such as bipyridyl compounds, a trend which has also been observed at bulk CdSe surfaces.¹⁸

In view of the strong complexing nature of bipyridyl ligands,¹⁹ we have synthesized a polyaromatic dye where the bipyridyl group is involved in the chromophoric system. We choose to synthesize the molecule 1,12-diazaperylene, which contains two nitrogen atoms at one of the two bay regions of the conjugated system as displayed in Scheme

(16) Vossmeier, T.; Katsikas, L.; Giernig, M.; Popovic, I. G.; Diesner, K.; Chemseddine, A.; Eychmüller, A.; Weller, H. *J. Phys. Chem.* **1994**, *98*, 7665.

(17) Lorenz, J. K.; Ellis, A. B. *J. Am. Chem. Soc.* **1998**, *120*, 10970.

(18) Lisensky, G. C.; Penn, R. L.; Murphy, C. J.; Ellis, A. B. *Science* **1990**, *248*, 840.

(19) Meyer, T. J. *Acc. Chem. Res.* **1989**, *22*, 163.

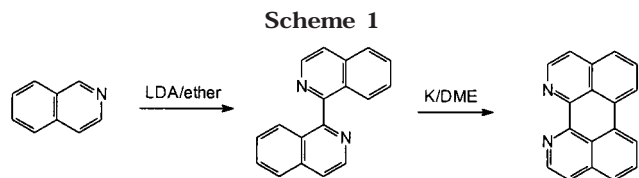

1. So far only the synthesis of 1,7- and 3,9-diazaperylene derivatives has been described in the literature^{20–22} whereas 1,12-diazaperylene has only been the subject of ab initio and HMO calculations.²³ The two-step synthesis of 1,12-diazaperylene starts from isoquinoline which is dimerized with LDA in ether to form 1,1'-biisoquinoline.²⁴ The cyclization reaction, which yields 1,12-diazaperylene, was inspired by the observation of Solodovnikov et al. who showed that 1,1'-binaphthyl spontaneously cyclizes through reduction with alkali metals.²⁵ For this particular anionic cyclization reaction, potassium in dimethoxyethane was used.

It turns out that diazaperylene can readily exchange TOPO from the surface of CdSe nanocrystals. This can be seen by investigation of the reaction product of semiconductor nanocrystals and chromophores, which has a very different solubility than the parent compounds. Whereas both isolated compounds are well soluble in toluene, the NC/dye complex, which is immediately formed after addition of excess dye solution to the colloidal nanocrystals at room temperature, precipitates right away. After separation, this product can be washed with toluene and redissolved in more polar solvents such as dichloroethane. The change in polarity of the prepared heterostructure as compared to the isolated compounds might be a result of charge separation upon attachment. The synthesis of the NC/dye complex and the corresponding NMR spectrum is shown in Figure 2. It can clearly be seen that the signals of the aromatic protons show strong broadening upon attachment to the nanocrystal surface and partially shift to lower field. There might be several reasons for the observed broadening such as, e.g., reduced rotational freedom, a variety of different microenvironments, or different orientations of the attached molecules with respect to the nanocrystal surface. However, the same experiments with pure perylene chromophores instead of diazaperylene did not show any of the effects mentioned above. Therefore, the absence of narrow peaks in the NMR spectra of the diazaperylene/NC solution together with the change of solubility is a strong argument that the formation of a NC/dye complex has taken place.

The strongest argument for the formation, however, is the change in the photophysics of the NC/dye heterostructure because the fluorescence of the nanocrystals is completely quenched upon attachment of the dye molecules. Interestingly, the quenching occurs for CdSe as well as CdSe/ZnS nanocrystals. For comparison, the optical spectra of the isolated compounds are shown in the upper graph of Figure 3. The solid lines show absorption and emission spectra of the diazaperylene in toluene. The lowest absorption band is centered at 442 nm and the emission is Stokes shifted by 10 nm. The dotted lines show

the absorption and emission spectra of CdSe nanocrystals, which are about 3 nm in diameter and covered with nominally one to two monolayers of ZnS. These particular nanocrystals have their first absorption band at 550 nm and exhibit a fluorescence quantum yield of more than 50% as compared to a common dye molecule (R6G) emitting at a similar wavelength.

The lower graph in Figure 3 shows optical spectra of the NC(CdSe/ZnS)-dye complex (solid lines) and the absorption of the pure nanocrystals for comparison (dotted line). From the extinction coefficients it can be estimated that the NC/dye ratio for this particular sample is 1/3. This value changes for bigger-sized nanocrystals where ratios of up to 20 dye molecules per nanocrystal were observed. We found that the absorption spectrum (abs.) of the NC/dye complex is not a pure superposition of the spectra for isolated dyes and nanocrystals. Instead, it shows an additional band at 474 nm, the origin of which is not absolutely clear yet. This band appears for any NC/dye complex investigated and depends neither on the nanocrystal size nor on the ZnS shell thickness.

A very interesting point to notice is that we could never detect nanocrystal fluorescence for any sample investigated after the dyes were attached to the surface. The inset in the lower graph of Figure 3 shows a fluorescence spectrum of the NC/dye complex upon excitation at 390 nm. This spectrum is quite similar to the fluorescence spectrum of the pure dye and shows no evidence of NC fluorescence. In addition the fluorescence excitation spectrum which was recorded at a detection wavelength of 590 nm, i.e., at a wavelength where mostly NC fluorescence is expected, only shows the features of the dye absorption including the extra band at 475 nm. The

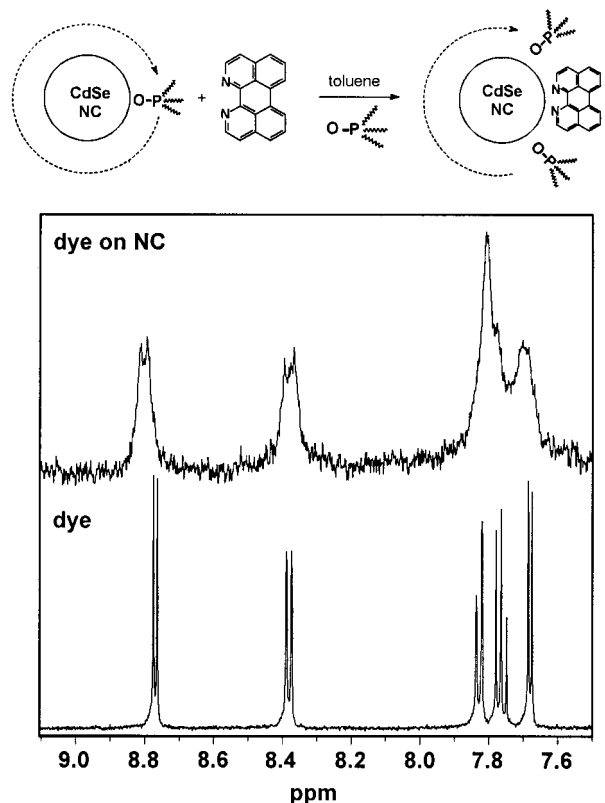

Figure 2 Scheme for the synthesis of nanocrystal-dye complexes and corresponding NMR spectra. While both isolated compounds are readily soluble in toluene, the NC-dye complex precipitates and can be redissolved in, e.g. chloroform. The NMR signals (in CD₂Cl₂) of the dye show massive broadening upon attachment of the dye to the NC surface.

(20) Naumann, C.; Langhals, H. *Chem. Ber.* **1990**, *123*, 1881.

(21) Tatke, D. R.; Seshadri, S. *Indian J. Chem., Sect. B* **1983**, *1197*, *Chem. Abstr.* **1984**, *101*, 54892g.

(22) Tatke, D. R.; Seshadri, S. *Dyes Pigm.* **1986**, *7*, 153. *Chem. Abstr.* **1986**, *104*, 188145u.

(23) Polansky, O. E.; Zander, M.; Mocz, M., I. *Z. Naturforsch.* **1983**, *38a*, 196.

(24) Ashby, M. T.; Govindan, G. N.; Grafton, A. K. *J. Am. Chem. Soc.* **1994**, *116*, 4801.

(25) Solodovnikov, S. P.; Ioffe, Yu, S. T.; Zaks, B.; Kabachnik, M. I. *Bull. Acad. Sci. USSR, Div. Chem. Sci. (Engl. Transl.)*, **1968**, 442.

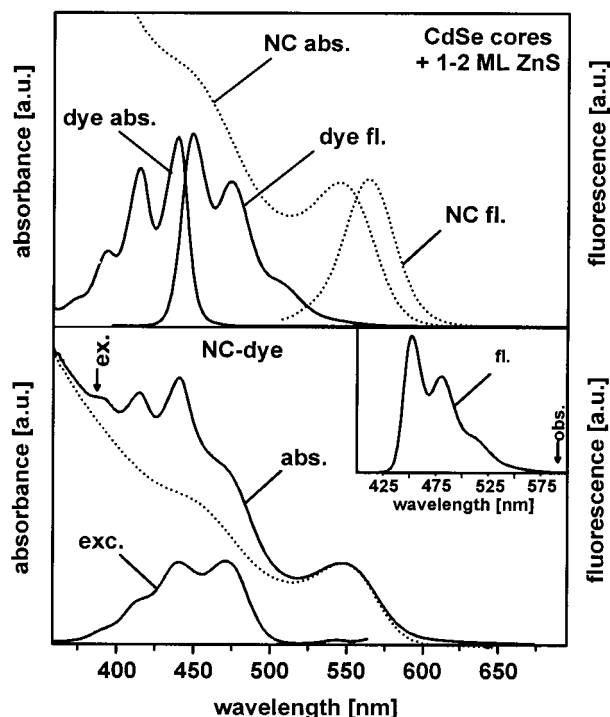

Figure 3 Fluorescence and absorption spectra of isolated compounds (top) and of NC/dye complex (bottom). The fluorescence and absorption spectra of the dye are almost mirror images while the nanocrystals show increasing absorption above the "band gap" and a symmetric fluorescence band (quantum yield approximately 50% for ZnS covered CdSe particles). The absorption spectrum of the NC/dye complex (abs.) is not a pure superposition of both spectra but shows an additional band at 470 nm. The inset in the lower graph shows the fluorescence spectrum of the NC/dye complex (fl.), which is very similar to that of the pure dye. As the fluorescence excitation spectrum (exc.) recorded at 590 nm reveals almost only dye absorption, the nanocrystal fluorescence is completely quenched. The fluorescence quenching is also observed in a wavelength region (500–600 nm) when only the nanocrystals are excited (for details see text).

absence of the absorption features of the nanocrystal suggests that the NC excited state is actively quenched by the dye even when the NC/dye compound is excited below the absorption threshold of the dye, i.e., between 500 and 600 nm where only nanocrystal absorption takes place.

Discussion

The origin of the additional band at 474 nm is not absolutely clear yet. There might be several reasons for this band, such as, e.g., the formation of interfacial electronic states upon attachment of the dye molecules to the nanocrystal surface or a change of the molecular environment upon attachment. To get a qualitative measure of possible environmental effects, we recorded absorption spectra of pure diazaperylene which was blended into a polymer or spin cast on a glass cover slip. For both samples we could observe a red shift of the absorption spectrum by about 30 nm. Therefore the change of the dye spectrum upon attachment might not reflect electronic interactions with the NCs such as a charge-transfer band. It might rather be due to different microenvironments which in turn lead to different classes of adsorbed dye molecules with variations in their absorption spectra. Another possibility for the change of the dye absorption spectra would be the formation of dye aggregates.²⁶ Additional theoretical calculations on the

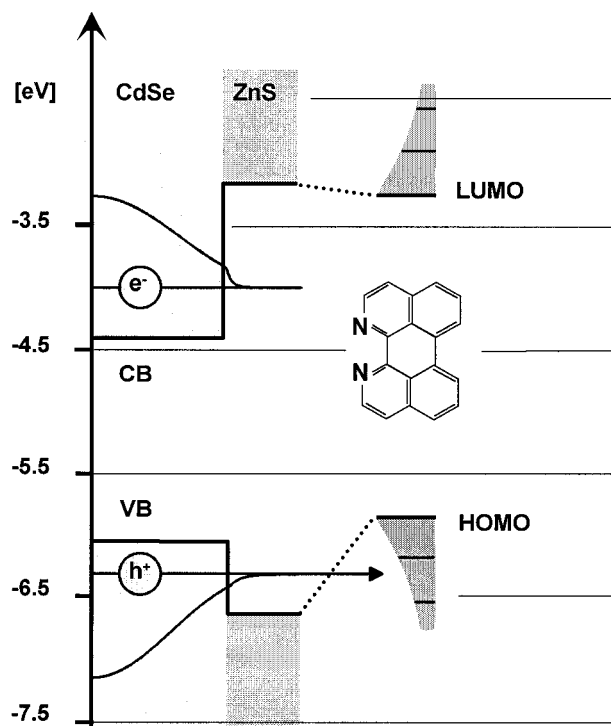

Figure 4 Electronic level scheme of the NC/dye complex. The shaded areas on the left-hand side show the conduction and valence bands of CdSe and ZnS, inside of which the quantized electron and hole levels and their wave functions are drawn. The right side shows the absolute positions of the HOMO and LUMO of diazaperylene as determined by CV measurements. The fact that the nanocrystal fluorescence is also quenched if only the NC and not the dye is excited suggests a hole transfer from the nanocrystal valence band to the HOMO of the attached dye molecule (for details see text).

electronic level structure of the diazaperylene dye and dye aggregates as well as their electronic interaction with semiconductor surfaces are needed to explain the absorption spectra of the NC/dye compound in all detail.

The effect of fluorescence quenching of the nanocrystals upon attachment of the dye molecules can be discussed by means of an electronic level structure that is shown in Figure 4. The shaded areas on the left side of the picture show the conduction and valence bands of macroscopic CdSe and ZnS in which the quantized electron and hole wave functions are drawn, respectively. The energetic positions of the CdSe bands are taken from ref 27, and the ZnS band offsets were taken from ref 28. In the solid-state language, photoexcitation of a semiconductor promotes an electron (e^-) from the valence band (VB) to the conduction band (CB) leaving a positive hole (h^+) behind. For small semiconductor nanocrystals, the absolute energy levels of the electrons and holes can be calculated to the first approximation using the "particle in a box" model where the box has the dimensions of the nanocrystal and the charge carriers have so-called "effective masses".²⁹ The energy levels and wave functions shown in Figure 4 were calculated with an extended effective mass approach taking into account the Coulomb interaction of electrons and holes and finite barrier heights at the particle boundaries.³⁰ The right side of the picture shows the

(26) Mahrt, J.; Willig, F.; Stroock, W.; Weiss, D.; Kietzmann, R.; Schwarzburg, K.; Tufts, B.; Trösken, B. *J. Phys. Chem.* **1994**, *98*, 1888.

(27) Grätzel, M. In *Photocatalysis-Fundamentals and Applications*; Wiley: New York, 1989.

(28) Wie, S. H.; Zunger, A. *Appl. Phys. Lett.* **1998**, *72*, 2011.

(29) Brus, L. E. *J. Phys. Chem.* **1986**, *90*, 2555.

absolute energetic positions of the HOMO and LUMO for the diazaperylene dye which were determined by cyclic voltammetry (CV). By comparison of the molecular levels of the dye molecule with the quantized electronic levels of the semiconductor particle, it can be seen that the electronic levels are staggered; i.e., the HOMO and LUMO of the dye are energetically above the quantized hole and electron state of the NC, respectively. There is some uncertainty about the absolute position of the energy levels³¹ and band offsets which were taken from different measurements and calculations. However, the absolute energetic position of the HOMO of perylene chromophores attached to TiO₂ surfaces has been determined to be even at 5 eV below the vacuum level.³² This observation additionally supports the assumption that the energy levels of the CdSe/diazaperylene system are actually staggered, i.e., that one might expect electron transfer from the dye to the nanocrystal or hole transfer from the nanocrystal to the dye.¹¹ Interfacial electron transfer from the ligand to the particle is the basis of dye-sensitized solar cells³³ and might also happen in this model compound if the attached dye molecules are photoexcited. This assumption is supported by the fact that partial quenching of the dye luminescence could be observed for all samples investigated. On the other hand, the fluorescence of the nanocrystals is also quenched if the NC/dye structure is photoexcited at a wavelength where only the nanocrystal and not the dye absorbs, e.g., between 500 and 600 nm for the sample shown in Figure 3. This observation can be explained by the occurrence of an effective hole transfer from the valence band state of the nanocrystal to the occupied dye level (HOMO). In addition, as this effect is not reduced by overcoating the dot with ZnS, the hole might easily tunnel through the ZnS barrier. An alternative explanation might be the creation of interfacial electronic states upon the attachment of the dye molecules which lead to fast nonradiative decay pathways. Time-resolved fluorescence and absorption measurements are needed to further reveal the photophysics of the NC/dye heterostructures where the tunability of the CdSe band gap allows for a defined adjustment of the band offsets and the ZnS shell thickness changes the tunneling barrier for the charge carriers. Usually the adjustment of interfacial energy levels is accomplished by the preparation of different compounds which also alters the chemical nature of the interface. As the chemical composition of the investigated NC/dye system remains the same, semiconductor nanocrystals with attached dye molecules are very promising candidates for both fundamental research of charge transfer at surfaces as well as practical applications.

Summary

In summary, it is shown for the first time that supramolecular heterostructures can be synthesized from

(30) Schooss, D.; Mews, A.; Eychemüller, A.; Weller, H. *Phys. Rev. B* **1994**, *49*, 17072.

(31) Truong, T. B. *Chem. Phys.* **1983**, *77*, 377.

(32) Burfeindt, B.; Hannappel, T.; Strook, W.; Willig, F. *J. Phys. Chem.* **1996**, *100*, 16463.

(33) Miller, R. J.; Mcendon, G. L.; Nøzik, A. J.; Schmickler, W.; Willig, F. In *Surface Electron-Transfer Processes*; VCH: Weinheim, 1995.

(34) Peng, X.; Wickham, J.; Alivisatos, A. P. *J. Am. Chem. Soc.* **1998**, *120*, 5343.

CdSe semiconductor nanocrystals and organic fluorophores. The supramolecular system consisting of ZnS-covered CdSe nanocrystals with a defined number of diazaperylene chromophores attached to the particle surface shows very interesting optical properties and serves as a model structure for interfacial electron and hole transfer. It is shown that the optical properties of the nanocrystals can be strongly influenced by the surrounding ligands, even though the particles are passivated with a material of higher band gap. Therefore, the chemical and electronic structure of the ligands has to be taken into account when the particles are chemically modified for specific applications.

Experimental Section

NMR spectra were recorded on a Bruker DRX 500 spectrometer operating at 500 MHz for ¹H and 125 MHz for ¹³C. Chemical shifts are given in ppm relative to TMS. IR spectra were recorded on a Nicolet FT-IR 320 spectrometer. Field desorption mass spectra were recorded on a VG ZAB 2-SE-FPD mass spectrometer, acceleration voltage 8 kV. UV-vis spectra were recorded using a Bruins Instruments Omega 10 spectrometer. Fluorescence spectra were taken with a Hitachi F-4000 spectrometer. CV measurements of diazaperylene were performed in tetra-*n*-butylammonium hexafluorophosphate (TBAHFP)/CH₂Cl₂ vs Fc^{+/0}: $E_{1/2}^{\text{red}}$, -1.76 eV; $E_{1/2}^{\text{ox}}$, 0.95 eV (not reversible). Column chromatography was performed over Merck aluminum oxide 90 active basic (0.063–0.200 mm). 1,2-Dimethoxyethane was distilled from deep blue sodium/benzophenone solution. Dimethylcadmium was vacuum distilled; diethylzinc was filtered before using. All other starting materials and reagents were obtained from commercial sources and used without further purification.

CdSe nanocrystals (1) in a size regime between 2 and 5 nm in diameter were synthesized according to literature¹³ as modified by Katari and co-workers.¹⁴ Particles larger than 5 nm were prepared according to the multiple injection method developed by Peng and co-workers.³⁴ The synthesis of small CdSe clusters absorbing below 450 nm will be described in detail elsewhere. The ZnS passivation has been performed according to ref 15.

1,1'-Biisoquinoline (2) was synthesized according to the literature.⁵

1,12-Diazaperylene (3). In a Schlenk reaction flask under a stream of purified argon, 0.5 g (1.95 mmol) of 1,1'-biisoquinoline (**2**) was dissolved in 8 mL of dry 1,2-dimethoxyethane. Subsequently 1.29 g (33.1 mmol) of potassium, which was separated from its oxide layer and shredded into small pieces, was added. The reaction mixture was stirred under argon for 12 h at room temperature. At the end of the reaction, the mixture showed a deep blue color caused by the dianion. The remaining potassium, which conglomerated to one piece, was removed under argon and the solution was allowed to stir under a stream of dried air for additional 4 h. After disappearance of the blue color, the solvent was evaporated and the residue was chromatographed on aluminum oxide with THF. After recrystallization from dichloromethane 0.37 g (74%) of **3** were obtained as yellow needles.

¹H NMR (500 MHz, C₂D₂Cl₄): δ 8.72 (d, 5.5 Hz, 2H), 8.28 (d, 7.3 Hz, 2H), 7.74 (d, 7.9 Hz, 2H), 7.69 (dd, 7.9 Hz, 7.3 Hz, 2H), 7.61 (d, 5.5 Hz, 2H). ¹³C NMR (125 MHz, C₂D₂Cl₄): δ 151.0, 145.1, 137.3, 130.9, 127.7, 125.2, 122.5, 122.0. IR spectrum (KBr-Pressling) ν (cm⁻¹): 3035; 1604; 1572; 1554; 1375; 1346; 1288; 213; 1139; 833; 812; 795; 779; 757; 645; 546; 529; 465. FD-MS: $m/z = 254.3$ (100%) [M⁺].

Acknowledgment. This work has been supported by the "Stiftung Rheinland-Pfalz für Innovation" under Contract No. 8312-38 62 61/371. The authors thank Dr. Jochen Übe for CV measurements and Dr. Manfred Wagner for NMR measurements.

LA0016367