

University of Groningen

Efficient strategies for the one-step modification of Aminoglycoside antibiotics

Bastian, Andreas Alexander

IMPORTANT NOTE: You are advised to consult the publisher's version (publisher's PDF) if you wish to cite from it. Please check the document version below.

Document Version

Publisher's PDF, also known as Version of record

Publication date:

2012

[Link to publication in University of Groningen/UMCG research database](#)

Citation for published version (APA):

Bastian, A. A. (2012). *Efficient strategies for the one-step modification of Aminoglycoside antibiotics*. s.n.

Copyright

Other than for strictly personal use, it is not permitted to download or to forward/distribute the text or part of it without the consent of the author(s) and/or copyright holder(s), unless the work is under an open content license (like Creative Commons).

The publication may also be distributed here under the terms of Article 25fa of the Dutch Copyright Act, indicated by the "Taverne" license. More information can be found on the University of Groningen website: <https://www.rug.nl/library/open-access/self-archiving-pure/taverne-amendment>.

Take-down policy

If you believe that this document breaches copyright please contact us providing details, and we will remove access to the work immediately and investigate your claim.

Downloaded from the University of Groningen/UMCG research database (Pure): <http://www.rug.nl/research/portal>. For technical reasons the number of authors shown on this cover page is limited to 10 maximum.

Efficient Strategies for the One-Step Modification of Aminoglycoside Antibiotics

Andreas A. Bastian

Efficient Strategies for the One-Step Modification of Aminoglycoside Antibiotics

Andreas A. Bastian

Ph.D. thesis

University of Groningen

The Netherlands

September 2012

Zernike Institute PhD thesis series 2012-18

ISSN 1570-1530

ISBN book 978-90-367-5669-3

ISBN electronic 978-90-367-5668-6

Printed by Ipskamp Drukkers B.V., Enschede.

Cover picture: molecular structure of neomycin B (ChemDraw)

This Ph.D. thesis was carried out in the Zernike Institute for Advanced Materials (Groningen, The Netherlands) according to the Graduate School of Science (Faculty of Mathematics and Natural Science, University of Groningen).



university of
 groningen

faculty of mathematics and
 natural sciences

zernike institute for
 advanced materials

RIJKSUNIVERSITEIT GRONINGEN

Efficient Strategies for the One-Step Modification of Aminoglycoside Antibiotics

Proefschrift

ter verkrijging van het doctoraat in de
Wiskunde en Natuurwetenschappen
aan de Rijksuniversiteit Groningen
op gezag van de
Rector Magnificus, dr. E. Sterken,
in het openbaar te verdedigen op
vrijdag 14 september 2012
om 11.00 uur

door

Andreas Alexander Bastian

Geboren op 24 augustus 1981
te Gdingen, Polen

Promoter:

Prof. dr. A. Herrmann

Beoordelingscommissie:

Prof. dr. K. Loos
Prof. dr. G. Roelfes
Prof. dr. H. Börner

*“The scientist is not a person who gives the right answer,
he’s one who asks the right questions.”*

Claude Lévi-Strauss, 1964

This thesis is dedicated to my parents
for their love, endless support
and encouragement.

Table of Contents

1. Non-Covalent Protective Groups for the Modification of Synthetic & Natural Compounds	1
1.1 Introduction	2
1.2 Metal-Chelates as Non-Covalent Protection in Polyamines	4
1.2.1 Regioselective Modification of Aminoglycoside Antibiotics	4
1.2.2 Regioselective Modification of Amino Acids	6
1.2.3 Regioselective Modification of Polyazamacrocycles	7
1.3 Macrocycles as Supramolecular Protective Groups	9
1.3.1 Calix[4]pyrrole Derivative as Protective Group for Polyphenols	9
1.3.2 Calix[6]pyrrole Derivative as Protective Group for a Triamine	11
1.3.3 Crown ether as Non-Covalent Protective Group for Amino Compounds	13
1.4 Non-Covalent Protection of Active Sites in Enzymes from PEGylation	17
1.5 Nucleoprotein as Sequence-Specific Protective Group for DNA Molecules	20
1.6 Motivation & Thesis Overview	23
1.7 References	26
2. Aptameric Protective Groups for One-Step Modification of Aminoglycoside Antibiotics	33
2.1 Introduction	34
2.2 Results & Discussion	35
2.2.1 Regioselective Acylation of Neomycin B Employing RNA as APGs	35

2.2.2	Regioselective Acylation of Neomycin B Employing Different APGs . . .	39
2.2.3	Regioselective Modification of a Related Antibiotic	41
2.3	Conclusion	42
2.4	Experimental Section	43
2.4.1	Materials & Methods	43
2.4.2	General Procedures	44
2.4.2.1	Synthesis of Activated Ester for Antibiotic Modification	44
2.4.2.2	Regioselective Acylation of Aminoglycoside Antibiotics	44
2.4.3	Characterization of Activated Esters & Antibiotic Derivatives	46
2.4.4	NMR Spectra of Antibiotics & Synthesized Antibiotic Derivatives	50
2.4.5	Comparison of 2D-NMR & Attached Proton Test	53
2.4.6	HPLC Analysis of Regioselective Acylation of Antibiotics	55
2.4.7	Conventional Synthesis of Neomycin B Modified at Ring IV	56
2.5	References	58
3.	Elucidation of the Mode of Action of Aptameric Protective Groups	61
3.1	Introduction	62
3.2	Results & Discussion	63
3.2.1	RNA Aptamers as APGs & Their Binding Sites	63
3.2.2	Dependence of Regioselectivity on APG/Antibiotic Ratio	64
3.2.3	Dependence of Regioselectivity on Reaction Time	67
3.2.4	Dependence of Regioselectivity on Salt Conc. & Temperature	69
3.3	Mode of Action of Aptameric Protective Groups	71
3.4	Conclusion	72
3.5	Experimental Section	72
3.5.1	Materials & Methods	72
3.5.2	General Procedure for Regioselective Acylation of Neomycin B	73
3.5.3	Characterization of Synthesized Neomycin B Derivative	75
3.5.4	NMR-Spectra of Synthesized Neomycin B Derivatives	76
3.5.5	High Resolution Mass Spectrometric & High Performance Liquid Chromatography Analyses	79
3.5.6	Isothermal Titration Calorimetry	80

3.6 References	83
4. Aptameric Protective Groups Enable Various Transformations in Different Positions of Neamine Antibiotics	85
4.1 Introduction	86
4.2 Results & Discussion	89
4.2.1 Regioselective Modification of Antibiotic's Ring IV in 6C Position	89
4.2.1.1 Modification Using Negatively Charged Activated Ester	89
4.2.1.2 Introduction of a Sulfhydryl Group using <i>Traut's</i> Reagent	92
4.2.2 Regioselective Modification of Antibiotic's Ring IV in C2 Position Employing Urea Bond Formation	95
4.2.3 Regioselective Mono- & Di-Functionalization of Neomycin B	99
4.2.3.1 Regioselective Azide Introduction at Antibiotic's Ring IV	99
4.2.3.2 Regioselective Urea Bond Formation at Antibiotic's Ring IV	101
4.3 Conclusion	105
4.4 Experimental Section	106
4.4.1 Materials & Methods	106
4.4.2 General Procedures	107
4.4.2.1 Synthesis & Characterization of Reagents for Antibiotic Modifications	107
4.4.2.2 Regioselective Transformations at Antibiotic's Ring IV	109
4.4.2.2.1 Acylation in C6 Position of Neomycin B	109
4.4.2.2.2 Urea Bond formation in C2 & C6 Position of Neomycin B	110
4.4.2.2.3 Azide Introduction in 2C & 6C Position of Neomycin B	111
4.4.3 Characterization of Synthesized Antibiotic Derivatives	112
4.4.4 NMR Spectra of Neomycin B & Synthesized Antibiotic Derivatives	121
4.4.5 High Resolution Mass Spectrometric Analysis	130
4.4.6 High Performance Liquid Chromatography Analysis	132
4.5 References	134

5. Regioselective One-Step Diazo-Transfer Reaction in C3 Position of Neamine	
Antibiotics	137
5.1 Introduction	138
5.2 Results & Discussion	139
5.2.1 Identification of Reaction Conditions for Regioselective Azide	
Introduction	139
5.2.2 Identification of Position of Diazotation	143
5.2.3 Regioselective Azide Introduction in Other Neamine Antibiotics	144
5.3 Conclusion	146
5.4 Experimental Section	147
5.4.1 Materials & Methods	147
5.4.2 Synthesis of Diazo-Transfer Reagent	148
5.4.3 General Procedures for Regioselective Azide Introduction	148
5.4.4 Characterization of Synthesized Antibiotic Derivatives	150
5.4.5 NMR Spectra of Neomycin B & Synthesized Antibiotic Derivatives	154
5.4.6 High Resolution Mass Spectrometric Analysis	161
5.5. References	163
6. Summary	165
6.1 Summary (english)	166
6.2 Samenvatting (nederlands)	170
6.3 Streszczenie (po polsku)	174
6.4 Zusammenfassung (deutsch)	177
Acknowledgements	183

Chapter 1

Non-Covalent Protective Groups for the Modification of
Synthetic and Natural Compounds

1.1 Introduction

Most natural products and therapeutics exhibit several functional groups, such as hydroxy-, amino-, olefin-, carboxy-, keto- and sulfhydryl groups. These functionalities are known to be essential for the biological activity and they are often targets for specific modification for the development of new actives with the aim of overcoming anti-drug resistance, increasing drug efficiency or decreasing toxicity.^{1,2} For example, the semi-synthetic antibiotic amikacin **1** (Fig. 1.1) derives from acylation of a specific amino group of the natural aminoglycoside kanamycin A³ and is used for the treatment of multidrug-resistant tuberculosis.^{4,5} Similarly, the etherification of a hydroxy group of the immunosuppressant drug sirolimus resulted in the new therapeutic everolimus **2**, which is applied for the treatment of renal cell carcinoma and neuroendocrine tumors (Fig. 1.1).⁶

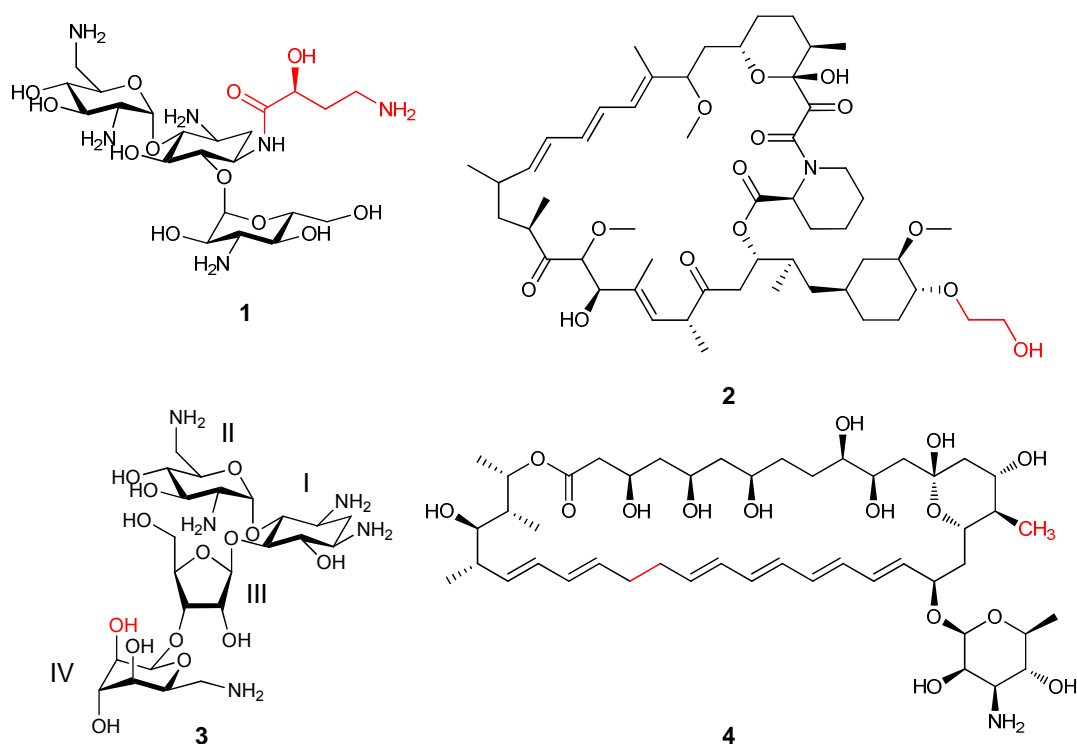
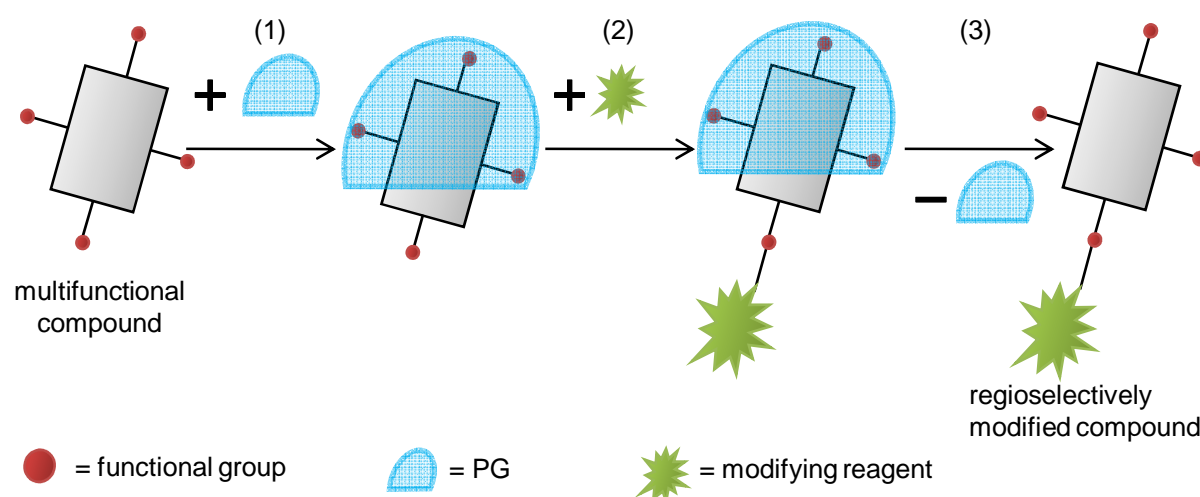

Figure 1.1: Molecular structures of modified natural compounds. Red colored structural unit indicates the modification of the corresponding molecule.

The functional groups within such multifunctional compounds can have equal or similar reactivity. Therefore, reactions of these molecules resulted often in a mixture of inseparable derivatives.^{7,8} To obtain structurally complex compounds modified at a specific molecule site, laborious and time consuming part or total synthesis has to be employed including multiple

steps for the introduction and cleavage of covalent protective groups. For example, the introduction of a single hydroxy group at ring IV of neamine antibiotic neomycin B resulting in derivative **3** (Fig. 1.1) required more than 20 synthetic steps.⁹ Another way to obtain specific analogues of multifunctionalized compounds is to apply enzyme catalysis^{10,11} or combinatorial biosynthesis.¹² For example, polyene analogue **4** (Fig. 1.1) which derives from macrolide antibiotic nystatin was obtained using modular polyketide synthases.² However, all these techniques exhibit serious limitations, such as the availability of genetically modified organisms, the laborious route of multistep organic synthesis or the restricted number of available enzymes. One alternative approach for mastering some of these challenges is the application of non-covalent protective groups (Scheme 1.1).¹⁰⁻²³ It was demonstrated that non-covalent protective groups can block temporarily several functionalities of a compound by non-covalent interactions, while functional groups not in contact with the protective group can be transformed regioselectively (Scheme 1.1).



Scheme 1.1: Site-specific modification of a multifunctionalized compound employing non-covalent protective groups: Introduction of protective group (1), regioselective transformation (2), removal of protective group (3).

Non-covalent protective groups can be divided in several classes, namely transition-metal chelated complexes,¹³⁻¹⁷ macrocycles,¹⁸⁻²² polymer conjugates²⁴ and enzymes^{25,26} and they were utilized for regioselective modification of polyamino- and polyphenolic compounds, amino acids, enzymes and nucleic acids.

1.2 Metal-Chelates as Non-Covalent Protection in Polyamines

Polyamino compounds are represented by many important molecule classes such as carbohydrates, peptides, amino acids, biogenic amines and polyazamacrocycles. Due to their biological function many members of these classes represent therapeutics or are metabolites which are important as diagnostic markers.²⁷⁻³⁰ In the following paragraphs site-specific modifications of polyamino compounds are described employing a non-covalent protection strategy based on metal-chelate formation.

1.2.1 Regioselective Modification of Aminoglycoside Antibiotics

Neamine aminoglycosides represent an important class of antibiotics. They are applied against Gram-negative and Gram-positive bacteria^{14,15,27,31,32} and have anti-HIV activity.³³ Since the mechanism of bacterial resistance against these antibiotics is well understood, modification of aminoglycosides is becoming a promising tool to overcome antibacterial resistance. *Zhou et al.* and *Yang et al.* reviewed the extensive work about synthesis of new derivatives of aminoglycoside antibiotics.³⁴⁻³⁷ However, it has to be emphasized that modification of these molecular structures requires multistep synthesis frequently employing conventional covalent protective group strategies.^{9,36,37} To simplify the synthesis of novel antibiotic derivatives, *Nagabhushan et al.* and *Hanessian et al.* introduced a method based on non-covalent protection to block several amino groups in aminoglycoside antibiotics and enabling regioselective modification of these carbohydrates.^{38,39} It was demonstrated that divalent transition metal ions, such as zinc(II), nickel(II) and copper(II) can block vicinal and non-vicinal amino- and hydroxy groups by metal-chelate complex formation. Amines not acting as ligand for the transition metal can be transformed regioselectively.^{13,38,39} Recently, this technique was successfully employed for the development of superior aminoglycoside antibiotics.¹⁴ *Aggen et al.* established the synthesis of the neoglycoside ACHN-490 **5** (Scheme 1.2) which has shown promising broad-spectrum activity against Gram-negative bacterial infections, including the highly resistant *Enterobacteriaceae*.¹⁴ As shown in Scheme 1.2, the intermediate, 6'-*N*-trifluoroacetyl sisomycin **6** was treated with the transition metal salt zinc(II)acetate to block the amino groups in C3 positions of ring I and II resulting in complex **7**. In the following step, unprotected amino groups of ring I and III were transformed regioselectively resulting in derivative **8**. Additional synthetic steps afforded the new antibiotic **5**.¹⁴

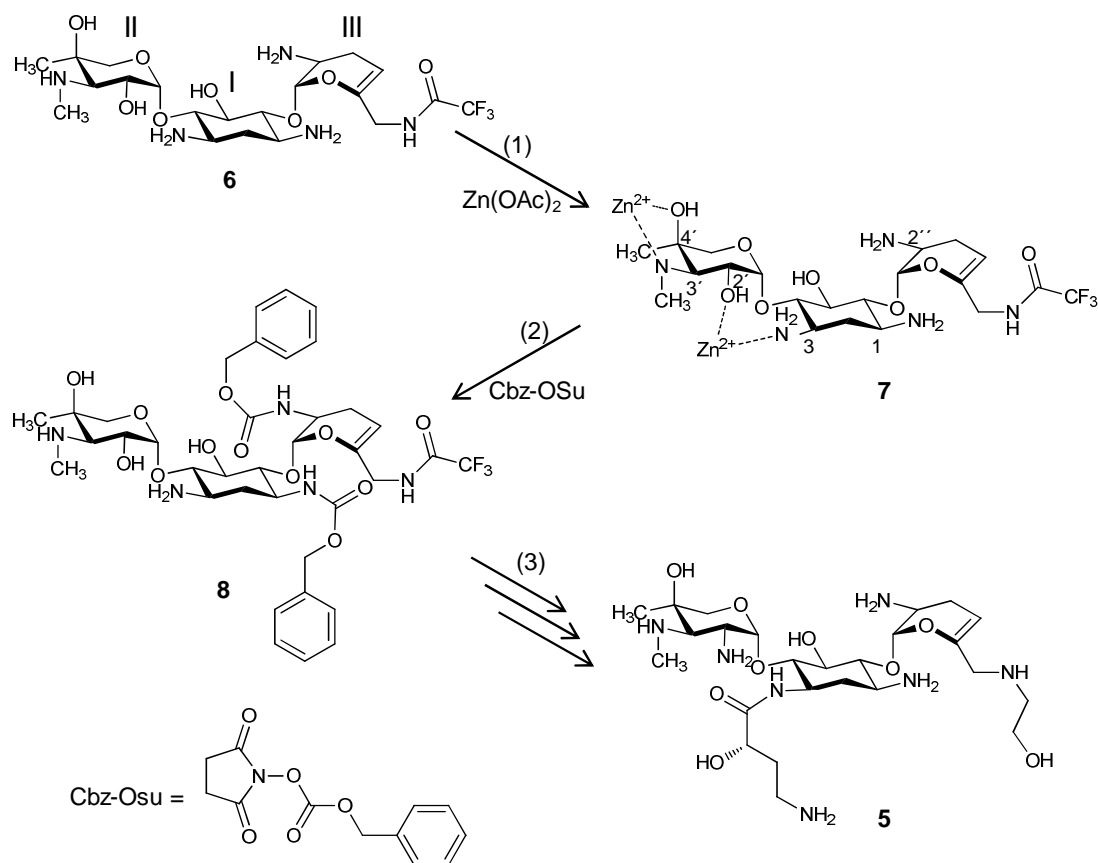

Scheme 1.2: Regioselective modification of an aminoglycoside using metal-chelate complex formation as non-covalent protective group: Metal-chelate complex formation (1), introduction of covalent protective group (2) and multi-step-synthesis to produce neoglycoside ACHN-490 (3).¹⁴

In a similar way, *Nudelman et al.* derivatized paromamine **9** using zinc(II)acetate as non-covalent protective group to obtain the 1-*N*-Boc protected aminoglycoside **10** (Scheme 1.3).¹⁵ This regioselective transformation was a key-step in the synthesis of the novel antibiotic NB54 **11** which showed reduced toxicity and enhanced suppression of disease-causing premature stop mutations.¹⁵

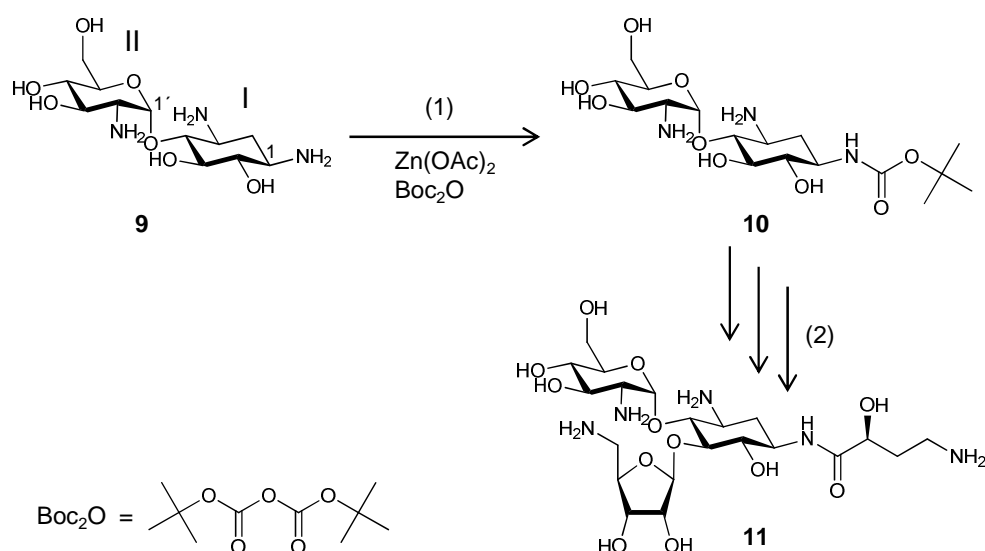

Scheme 1.3: Regioselective modification of paromamine **9** using Zn(II)-chelate complex formation as non-covalent protective group (1) and multi-step synthesis to obtain antibiotic NB54 (2).¹⁵

1.2.2 Regioselective Modification of Amino Acids

While aminoglycoside bear only hydroxy- and amino groups, the metal chelate method was also successfully employed for the regioselective derivatization of amino acids.^{13,40-43} These efforts have been recently summarized in a review by *Lee* and *Cheong*.¹³ As shown in Scheme 1.4, the α -amino group of amino acids 5-(*R*)-hydroxy-L-lysine **12a** and L-lysine **12b** was protected non-covalently by the interaction with copper(II) ions resulting in metal-chelate complex **13**.⁴⁰⁻⁴³ In the next step covalent protective groups (PGs), such as benzyl- (Bn), carboxybenzyl- (Cbz), fluorenylmethoxycarboxy (Fmoc) and *tert*-butylcarboxy groups (*tert*-Boc) were introduced regioselectively at the unprotected amine in ϵ -position resulting in amino acid derivatives **14a-c** (Scheme 1.4, Table 1.1).

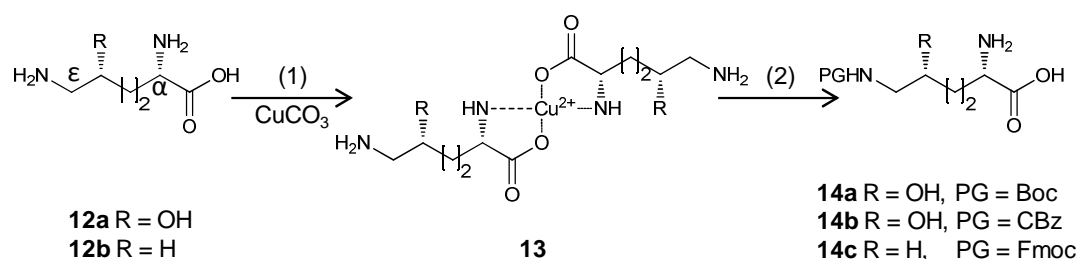

Scheme 1.4: Regioselective modification of amino acids **12a** and **12b**: Non-covalent protection of α -amino group using Cu(II)-chelate complex formation (1) and regioselective transformation of ϵ -amino (2).⁴⁰⁻⁴³

Table 1.1: Regioselective modification of ϵ -amino group of amino acids.

amino acid	product	reagents	yield (%)	ref.
12a	14a	a, $\text{CuCO}_3 \times \text{Cu}(\text{OH})_2 \times \text{H}_2\text{O}$ b, $(\text{Boc})_2\text{O}$, H_2O /dioxane	68	[40]
12a	14b	a, CuCO_3 , H_2O , reflux b, Cbz-Cl , NaHCO_3 , H_2O /dioxane	49	[41,42]
12b	14c	a, $\text{CuCO}_3 \times \text{Cu}(\text{OH})_2 \times \text{H}_2\text{O}$ b, Fmoc-N_3 , MgO c, $2\text{Na}^+ \times \text{EDTA}^{2-}$	70	[43]

1.2.3 Regioselective Modification of Polyazamacrocycles

Macrocyclic polyamines have been extensively investigated as catalysts and transport systems for metal ions.⁴⁴ Moreover, metal-polyazamacrocycle complexes have been also applied as radiopharmaceuticals and luminescence probes^{30,45,46} or as a model for the elucidation of enzymatic reactions, such as the hydrolysis of phosphate monoesters by alkaline phosphatase.^{44,47} In this sense, the synthesis of these macrocycles and their derivatization is an important goal, which has been the subject of several studies.⁴⁸⁻⁵² Nevertheless, the monofunctionalization of unsymmetrical macrocycles is still a challenging process and required multistep synthesis.^{53,54} *Burguete et al.* established a simple method for the selective modification of these polyamines based on non-covalent protection (Scheme 1.5).¹⁶ It was demonstrated that the coordination of divalent zinc ions allowed selective protection of three out of four amines in *tetra-aza*[n]paracyclophanes **15a-c** resulting in metal-chelate complex **16**. As shown in Scheme 1.5, the amino group not involved in complex formation was transformed regioselectively using an alkylation reagent resulting in derivatives **17a-i** (Table 1.2).

Chapter 1

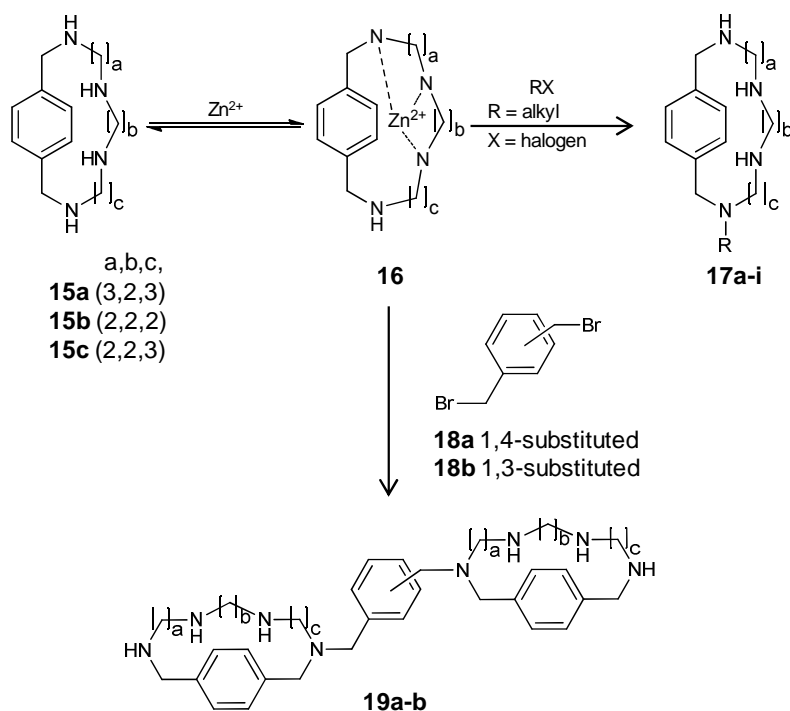

Scheme 1.5: Regioselective alkylation and dimerization of polyaza[n]macrocycles using metal-chelate complex formation as non-covalent protective group.^{16,17}

Table 1.2: Regioselective alkylation and dimerization of polyaza[n]macrocycles.

Amino acid	Product	residue R	Yield (%)	Ref.
15a	17a	vinyl	60	[16]
15a	17b	phenyl	56	[16]
15a	17c	ethoxycarbonyl	72	[16]
15a	17d	p-nitrophenyl	61	[16]
15a	17e	p-methylphenyl	64	[16]
15b	17f	vinyl	52	[16]
15c	17g	vinyl	89	[16]
15c	17h	ethoxycarbonyl	73	[16]
15c	17i	phenyl	79	[16]
15a	19a	--	87	[17]
15a	19b	--	78	[17]

In further studies *Burguete et al.* applied this method for the dimerization of the polyazamacrocycle **15a**.¹⁷ Using alkylation reagents 1,4-bis(halomethyl)aren **18a** and 1,3-bis(halomethyl)aren **18b** the polyamines **19a** and **19b** were obtained, respectively (Scheme 1.5, Table 1.2), exhibiting two macrocyclic subunits. Their synthesis was particularly important, since these so called ditopic polyazamacrocycles are known to have anti-HIV activity.^{55,56}

1.3 Macrocycles as Supramolecular Protective Groups

After discussing the use of small metal ions for the regioselective derivatization, in this paragraph the use of more complex macrocycles as non-covalent protective group is described. The most important classes of macrocycles are represented by calixarenes, cyclodextrines and crown ethers. Due to their variable cavity size these molecular architectures can act as host for a broad variety of guest molecules including metal cations, halogen anions, other charged and neutral compounds.^{57,58} Furthermore, it was shown that they can be applied as nanoreactors for various organic reactions,^{59,60} biomimetic receptors and multivalent ligands for biomolecular recognition.^{57,61} Since the early 80s macrocycles have been successfully utilized as non-covalent protective groups for amino- and hydroxy groups.¹⁸⁻²² In the following, their use as supramolecular protective groups (SPGs) is described for the regioselective modification of *di*-functionalized substrates and in peptide synthesis.

1.3.1 Calix[4]pyrrole Derivative as Protective Group for Polyphenols

Naphthoic acid and polyphenolic molecular structures are present in many well-known pharmaceuticals applied for the treatment of tuberculosis, malaria, cancer and infectious diseases.⁶²⁻⁶⁹ In course of the development of new therapeutics various methods have been introduced to enable site specific modification of the hydroxy group of naphthoic acids employing conventional synthesis⁷⁰⁻⁷⁵ and enzymatic approaches.⁷⁶⁻⁷⁹ To simplify the derivatization of polyphenolic substrates *Valenti et al.* investigated the application of calix[4]pyrrole derivative **20** as a macrocyclic non-covalent protective group for the regioselective etherification and esterification of 6-hydroxy-1-naphthol **21** (Scheme 1.6).^{18,80} As shown in Scheme 1.6, macrocycle **20** showed the preference for the selective non-covalent

protection of the β -phenolate moiety of **21** (Scheme 1.6).¹⁸ The resulting host-guest complex **22** based on π - π -interaction and hydrogen bonding was applied in the next step for regioselective alkylation and acylation of the hydroxy group in α -position. Applying one equivalent of benzyl bromide **23** and *trans*-crotonoyl chloride **24** the transformation of **21** in presence of calix[4]pyrrol **20** and cesium carbonate resulted mainly in alkylated naphthol derivative **25** and acylated derivatives **26**, respectively.

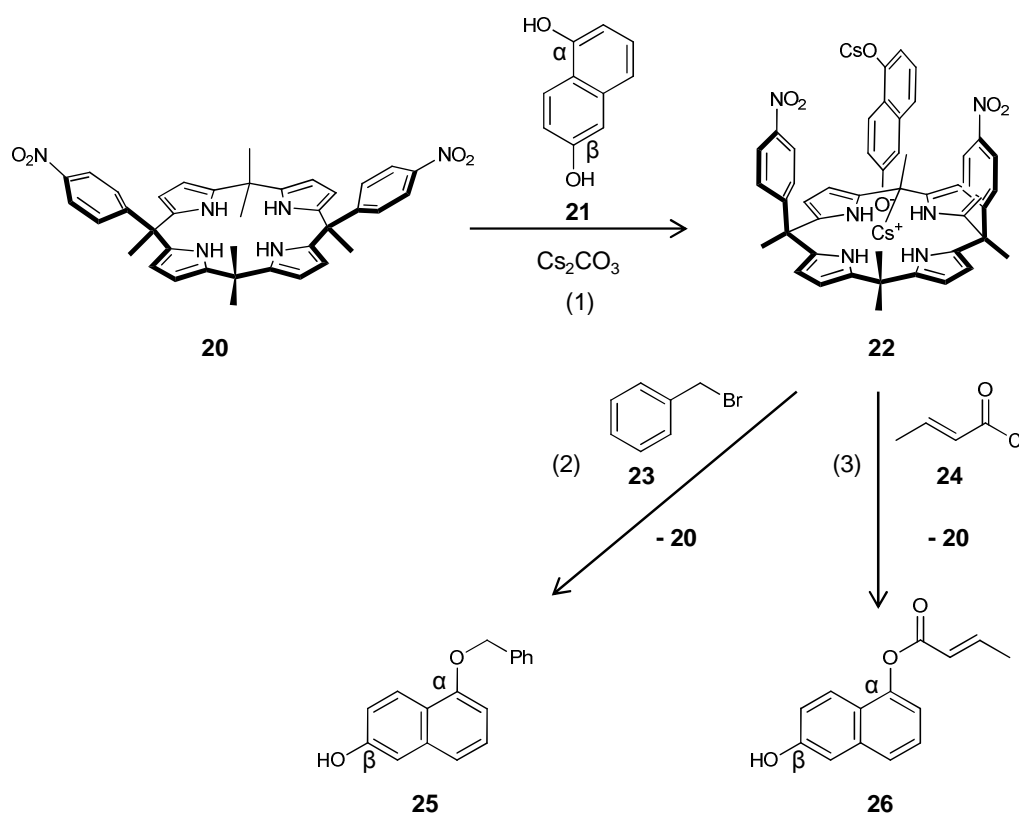

Scheme 1.6: Regioselective modification of hydroxy naphthol **21** employing calix[4]pyrrol **20** as SPG: Selective complexation (1), regioselective alkylation (2) and regioselective acylation (3).¹⁸

1.3.2 Calix[6]pyrrole Derivative as Protective Group for a Triamine

At the same time another example of macrocycles as SPGs was introduced acting as SPG by *Reinaud et al.* (Scheme 1.7).¹⁹ In contrast to a calix[4]arene derivative, *Reinaud et al.* applied a zinc(II)-funnel complex based on calix[6]arene ligand as SPG. Calixarene-zinc(II) complexes were extensively investigated in order to develop biomimetic receptors.⁸¹⁻⁸⁶ These studies demonstrated that zinc(II)-macrocycles can act as hosts for a various non-charged guest molecules of different molecular size and properties.^{81,83} In 2009, *Reinaud et al.* applied the calix[6]arene-zinc(II) complex **27** substituted with pyrrole units as a non-covalent protective group for the unsymmetrical triamine, *N*-(2-aminoethyl)propane-1,3-diamine **28** (Scheme 1.7).¹⁹

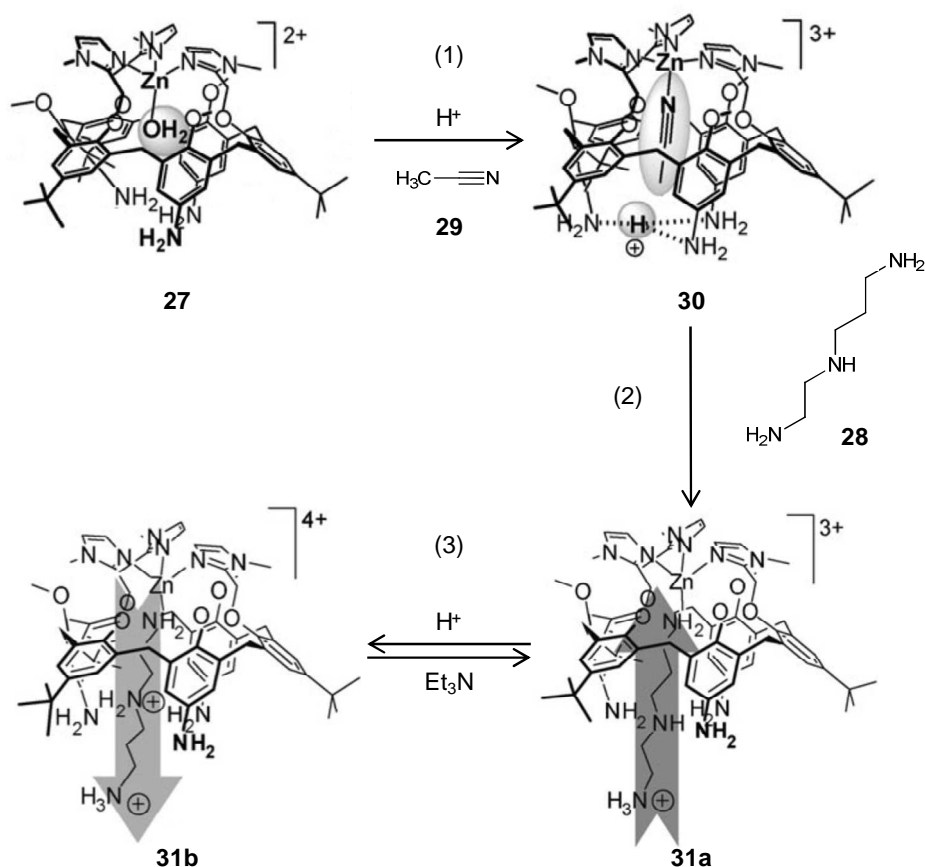

Scheme 1.7: Regioselective protection of triamine **28** using zinc-funnel complex **27**: Host-guest complex formation using acetonitril **29** as guest molecule (1), regioselective complex formation with guest molecule triamine **28** (2) and acid-base controlled direction of guest **28** in zinc(II)-macrocycle complex (3).¹⁹

As shown in Scheme 1.7, host-guest complex formation was performed in two steps. First, macrocycle **27** was treated with acetonitril **29** resulting in complex **30**. In the subsequent step guest **29** was replaced by triamine **28** (Scheme 1.7). It was demonstrated that the direction of the unsymmetrical triamine **28** in macrocycle **27** can be controlled by the protonation state of guest molecule **28**. As shown in Scheme 1.7, in presence of protonating agents the host-guest complex **31b** was formed, while under more basic conditions complex **31a** was preferred.¹⁹

To demonstrate that the zinc-funnel complex **27** can be applied as SPG, the host-guest complex **31a** was reacted with *tert*-butyl-oxycarbonyl (Boc) anhydride at the primary amino group of triamine **28** protruding into the solvent (Scheme 1.8).¹⁹ After optimization of reaction conditions, the carbamoylation of **28** was successfully performed using 1.2 equivalents of di-*tert*-butyl dicarbonate **32** resulting in complex **33**. Finally, decomplexation under basic conditions gave exclusively the monocarbamat **34**.¹⁹

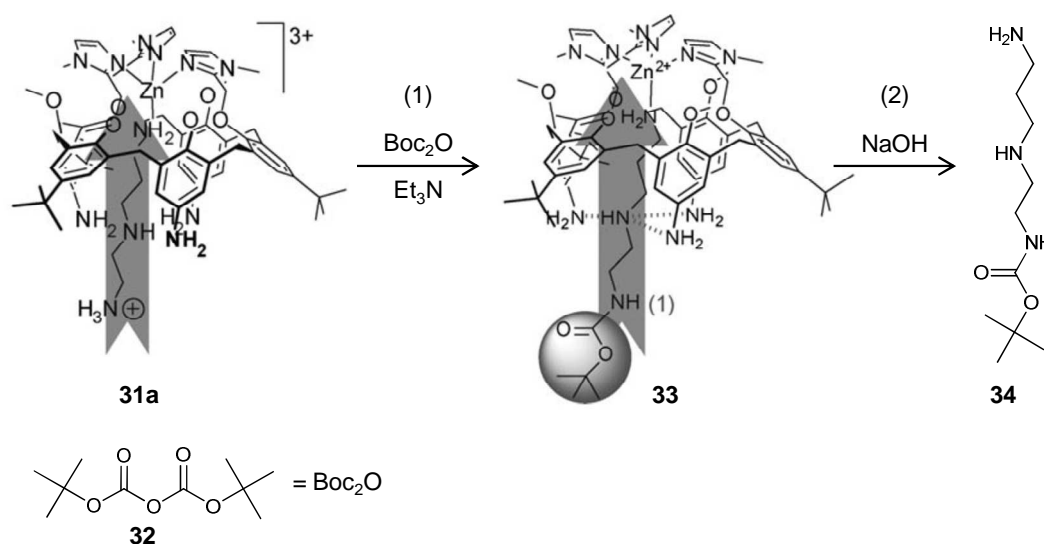

Scheme 1.8: Regioselective carbamoylation of triamine **28**: Transformation of the solvent exposed amino group of triamine **28** in complex **31a** (1), decomplexation of **34** under basic conditions (2).¹⁶

1.3.3 Crown Ether as Non-Covalent Protective Group for Amino Compounds

Since *Pederson et al.* reported that crown ethers can complex ammonium ions and solubilise these functional groups in apolar solvents⁸⁷ these macrocycles found application as non-covalent protective groups in peptide synthesis^{20,21} and in regioselective derivatization of difunctional compounds.²² Especially, the 18-crown-6 ether **35** (Scheme 1.9) was best suited as ligand for ammonium ions as demonstrated by *Bushmann and Mutihac*.⁸⁸ As shown in Scheme 1.9 the formation of the host-guest complex **36** is based on non-covalent hydrogen bonds between ether-oxygens of the macrocycle and hydrogens located at the ammonium group.^{89,90} Due to the tetrahedral configuration of complex **36**, the ammonium group is located above the cavity of the macrocycle and the guest molecule is sterically unhindered and available for transformation.

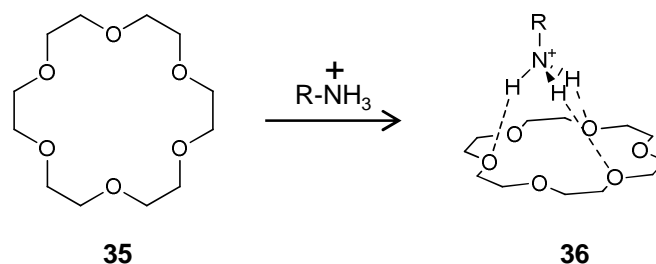

Scheme 1.9: Mode of non-covalent protection of an ammonium group by 18-crown-6 ether **35**.^{89,90}

In 1990, *Hyde and Masscagni* applied crown ether **35** as SPG for the synthesis of the pentapeptide derivative **37** of the endogen peptide enkephalin (Scheme 1.10). To obtain the pentapeptide **37**, peptide bond formation between dipeptide **38** and tripeptide **39** was employed (Scheme 1.10).²⁰ To avoid unspecific peptide bond formation, the α -amino group of **38** was protected non-covalently by crown ether **35** resulting in complex **40**. In subsequent step, the N-terminus of tripeptide **39** was selectively coupled with the carboxy function of protected dipeptide **38** resulting in complex **41**. Decomplexation of the amino group applying saturated potassium chloride solution yielded the enkephalin derivative **37**.²⁰

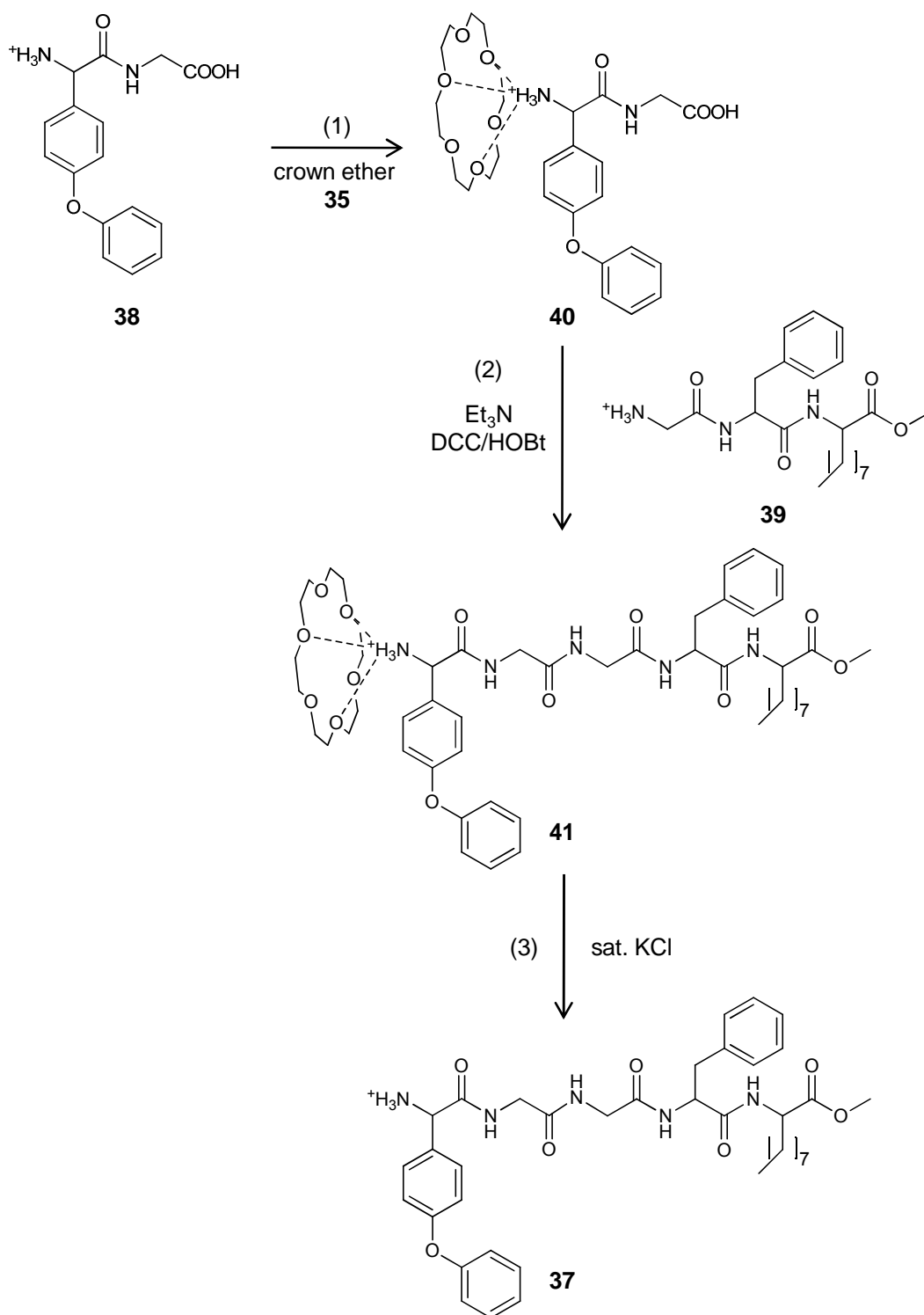

Scheme 1.10: Synthesis of enkephalin derivative **37** employing crown ether **35** as non-covalent protective group for blocking a terminal amino group: Crown ether complex formation (1), selective peptide coupling reaction (2) and deprotection of the terminal amine (3).²⁰

Exploiting the crown ether protection further, *Mascagi et al.* demonstrated that 18-crown-6 ether **35** can also be applied as non-covalent protective group in solid-phase peptide synthesis.²¹ In order to maximize the coupling yield the peptide synthesis conditions were optimized to stabilize the crown ether complex. Thus, the influence of solvent polarity and the counter anion on the complex stability were investigated. It was demonstrated that the complex stability between the N-terminal amino group of the peptide and the crown ether **35** increases with decreasing solvent polarity and the presence of tosylate (Tos^-) as counter ion and therefore, these conditions resulted in minimized side product formation during the coupling reaction. Moreover, the efficiency of the peptide bond formation increases significantly, when proline was chosen as the N-terminal amino acid of the immobilized peptide. As shown in Scheme 1.11, the same conditions were successfully applied for condensation of even larger peptide-fragments.²¹ The crown ether protected pentapeptide **42** was reacted with immobilized tetrapeptide **43** in dichloromethane (DCM) resulting in immobilized nonapeptide complex **44**. Deprotection of the α -amino group with *di*-isopropylethylamine (DIPEA) and cleavage of the peptide from the resin resulted in nonapeptide **45** reaching a coupling yield of remarkable 88 %.²¹

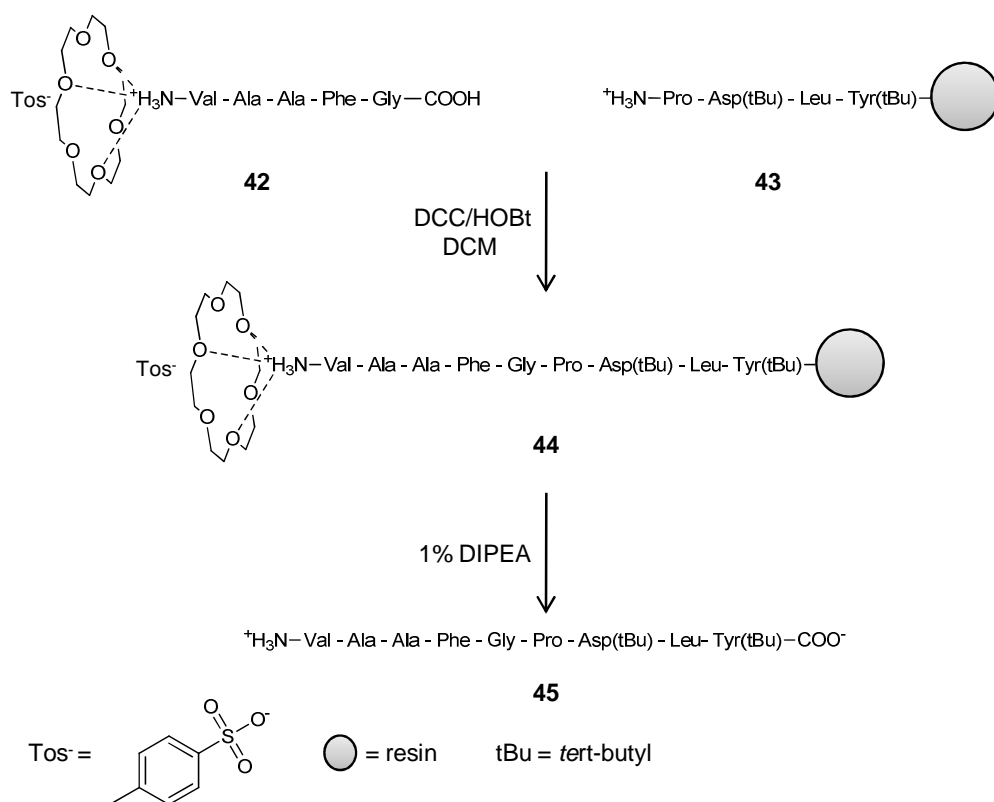

Scheme 1.11: Solid-phase peptide fragment coupling employing crown ether **35** as non-covalent protective group for the N-terminus.²¹

To facilitate the amine deprotection, product isolation and the regeneration of the crown ether, *Haswell et al.* established a method for the regioselective modification of difunctional organic molecules using an immobilized crown ether as in-situ protection group in a flow reactor.²² Hence, aminomethyl-18-crown-6 ether **46** was coupled to a carboxypolystyrene resin **47** to afford immobilized macrocycle **48** (Scheme 1.12).

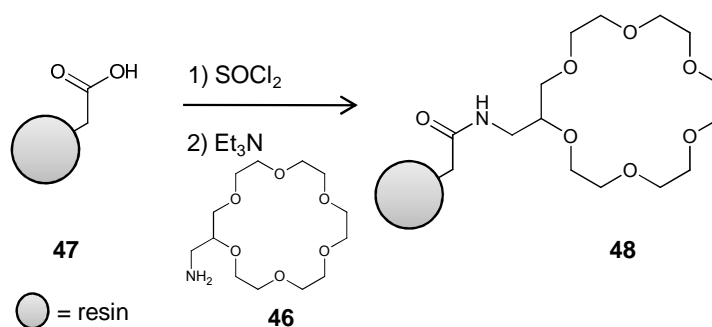

Scheme 1.12: Immobilization of methylamine crown ether **46**.²²

As shown in Scheme 1.13, the immobilized crown ether **48** was successfully employed as SPG for the regioselective modification of tyramines **49a** and **49b**, exhibiting a hydroxy and amino group with similar reactivity. The subsequent complexation of **48** with compounds **49a** and **49b** resulted in complexes **50a** and **50b**, respectively. In the following step the exposed phenolic hydroxy group was converted applying acylation and alkylation reactions, while the protected amine was not reactive. Hence, reaction of **50a** and **50b** with acetic acid anhydride **51** and methyl iodide **52** resulted in formation of complexes **53**, **54a** and **54b**, respectively. Deprotection of the amino group in presence of potassium chloride afforded tyramine derivatives **55**, **56a** and **56b** reaching quantitative conversions. The immobilized crown ether **48** was recycled in an additional washing step of potassium crown ether complex **57** with acetic acid in methanol.²²

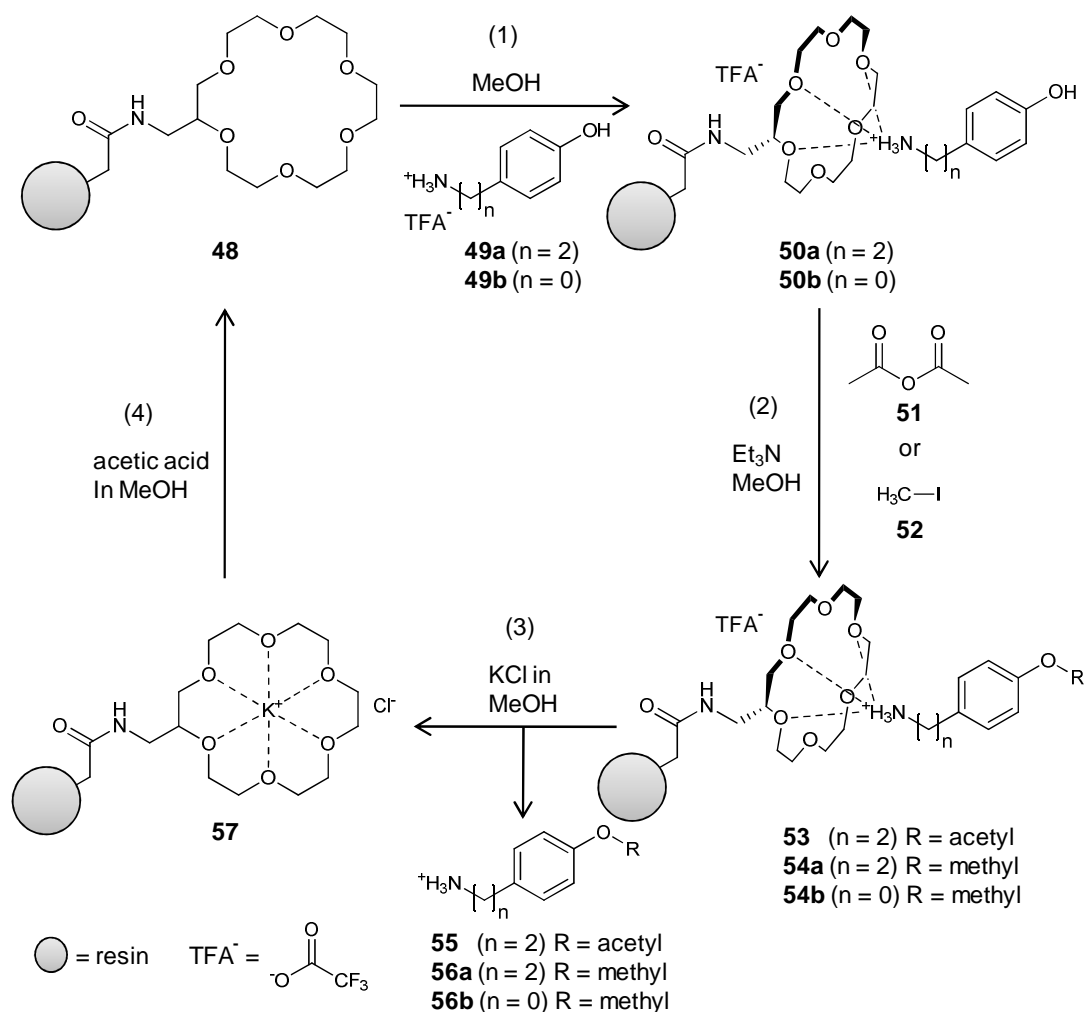

Scheme 1.13: Regioselective modification of tyramines **49a** and **49b** using immobilized crown ether **48** as non-covalent protective group: Crown ether complex formation (1), chemical transformation (2), decomplexation (3) and regeneration of **48** (4).²²

1.4 Non-Covalent Protection of Active Sites in Enzymes from PEGylation

After describing the utilization of non-covalent protective group approaches for peptide synthesis, this paragraph deals with SPGs for the derivatization of proteins. The introduction of poly(ethylene glycol), called PEGylation, in enzymes and proteins is a well established strategy in the development of new therapeutics.⁹¹⁻⁹³ PEG conjugation reduces renal ultrafiltration of proteins, proteolytic degradation of enzymes and improves their solubility in organic solvents.^{92,93} Furthermore, masking of enzymatic surfaces by polymers reduces immunogenicity and antigenicity extending the residence time of enzymes in the body.⁹⁴⁻⁹⁷

However, PEGylation can result in dramatically decrease of the enzymatic or biological activity.^{23,24} The reason is that during the conjugation process PEG chains can be introduced in the active site of an enzyme erasing its activity. To overcome this limitation two strategies were developed preventing PEGylation of the active site.^{23,24}

For example, *Veronese et al.* applied the specific interaction between a substrate and the enzyme to block non-covalently the active site during PEGylation.²³ This approach was demonstrated on the enzyme uricase **E1** (urate oxidase) which catalyses the oxidation of uric acid **57** to allantoin **58** (Fig. 1.2a) and is applied for the therapy of hyperuricemia.⁹⁸

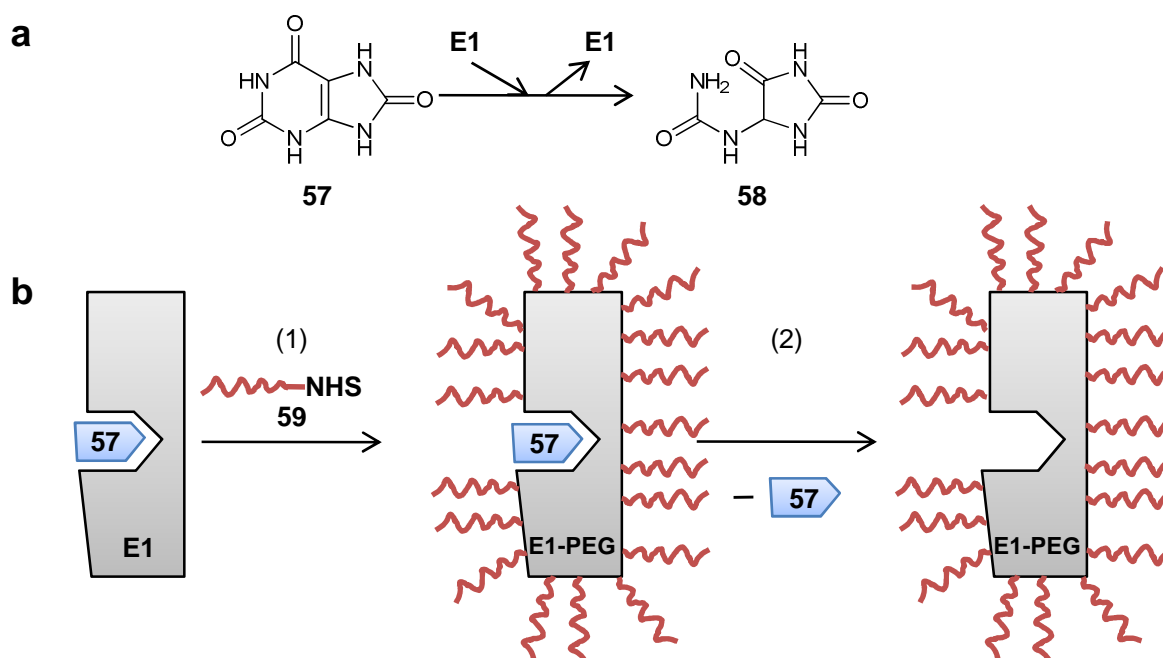
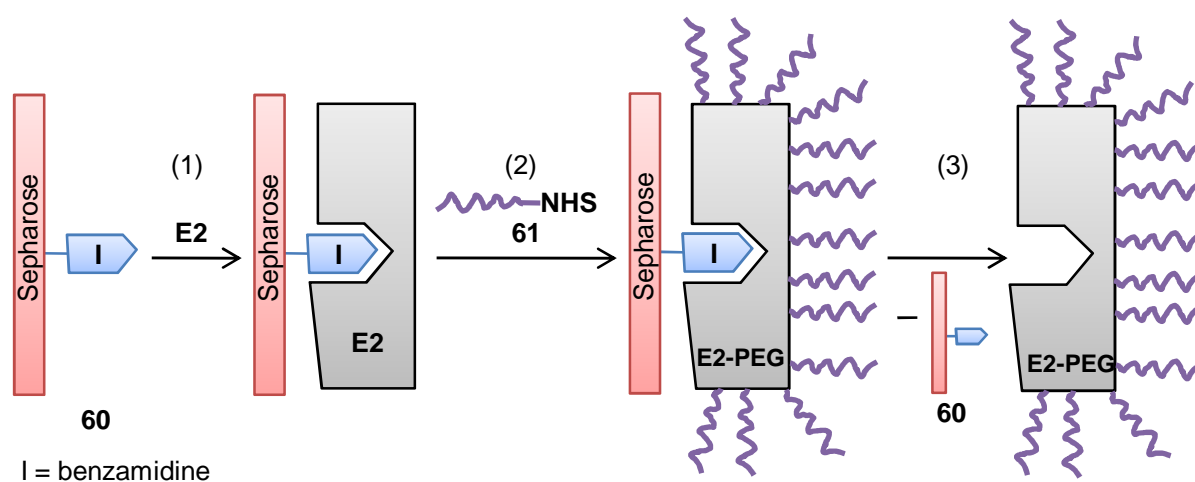

Figure 1.2: a, Enzymatic reaction catalyzed by uricase **E1**. b, PEGylation of enzyme **E1** in presence of substrate **57** acting as non-covalent protective group for the active site: PEGylation (1) and elution of substrate **57** (2).²³

As shown in Figure 1.2b, to prevent the modification of the active site the enzyme **E1** was incubated with linear PEG-norleucin-*N*-hydroxysuccinimide ester (PEG-Nle-NHS) **59** in presence of substrate **57**. The resulting PEGylated enzyme **E1-PEG** (Fig. 1.2b) was characterized and it turned out that an enzymatic activity of 40 % remains, while the enzyme PEGylated in absence of the substrate exhibited no activity at all.²³ However, the relatively low enzymatic activity of conjugated protein **E1-PEG** can be explained by the fact that also PEG chains were introduced in the surrounding area of the active site. This gave rise to hinder the binding of substrate **57**.²³

To protect both, the active site and its proximity, from PEGylation the same group introduced a new method employing an inhibitor immobilized on an insoluble resin as non-covalent protection of serine protease trypsin **E2** (Scheme 1.14).²⁴ The inhibitor, benzamidine, had the function to protect the active site of the enzyme, while the resin (Sephacrose) should inhibit the conjugation of the surrounding surface area of the protein. As shown in Scheme 1.14, the enzyme **E2** was first immobilized on the inhibitor resin conjugate **60**. In the next step, the enzyme was treated with monomethoxy-PEG -Nle-NHS **61** resulting in PEGylated protein **E2-PEG**. Investigation of the modified protein **E2-PEG** revealed that the enzymatic activity was maintained to a degree of 95 %, while the conjugation in absence of the inhibitor resulted in a PEGylated enzyme with an activity of only 25 % compared to a non-modified **E2** reference.²⁴



Scheme 1.14: PEGylation of trypsin employing inhibitor resin conjugate **60** as non-covalent protective group for the active site and surrounding protein surface: Immobilization of enzyme **E2** on resin (1), regioselective PEGylation of exposed enzymatic surface (2) and elution of modified enzyme **E2-PEG** (3).²⁴

1.5 Nucleoprotein as Sequence-Specific Protective Group for DNA Molecules

While protein can be functionalized avoiding modification of the active site with the help of supramolecular protection strategies, proteins itself can act as SPGs as will be detailed in the following paragraph.

In order to develop nanometer-scale electronic devices in 1998 *Braun* and *Ben-Yoseph* introduced the formation of metallic conductive wires by coating DNA molecules with a metal, which can then be attached to macroscopic electrodes using their molecular recognition abilities.^{100,101} To allow more elaborate manipulations during the preparation of these microelectronic devices, in further studies *Braun et al.* established a sequence-specific molecular lithography technique.²⁵ It was demonstrated that the enzyme RecA, a major protein responsible for genetic recombination in bacteria,¹⁰²⁻¹⁰⁴ can be applied in combination with a single stranded DNA (ssDNA) as sequence-specific non-covalent protective group during molecular lithography and subsequent metallization of double stranded DNA molecules (dsDNA) (Fig. 1.3).²⁵

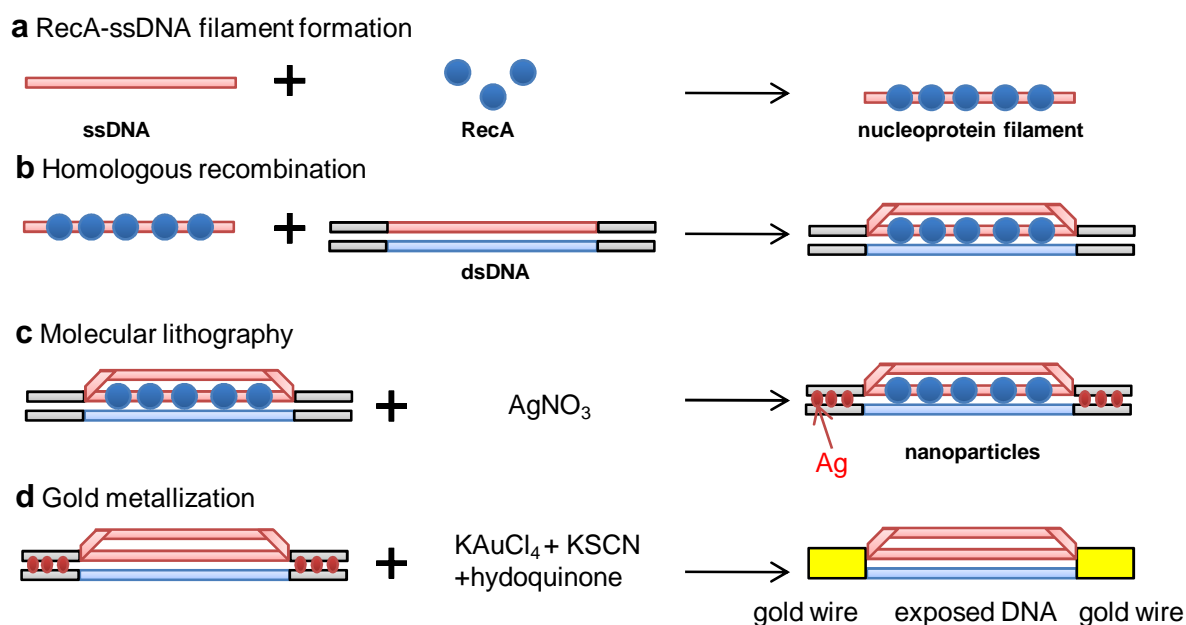

Figure 1.3: Sequence-specific lithography and metallization of dsDNA substrates employing RecA-ssDNA nucleoprotein filament as non-covalent protective group.²⁵

As shown in Figure 1.3a, RecA was first polymerized on ssDNA resulting in a nucleoprotein complex, which could interact with aldehyde-derivatized dsDNA substrate. The sequence-specific protection of this substrate was enabled by homologous recombination, the formation of a three-way junction of the nucleofilament and the corresponding sequence of dsDNA (Fig. 1.3b and 1.4a). As shown in Figure 1.3c and Figure 1.4b, RecA was acting as protecting group hindering the reduction of silver on the recombined fragment during the molecular lithography process. The subsequent Gold metallization of dsDNA which is catalyzed by the silver aggregates (Fig. 1.3d) resulted in gab formation as proven by atomic force microscopy (AFM, Fig.1.4c) and scanning electron microscopy (SEM, Fig. 1.4d).²⁵

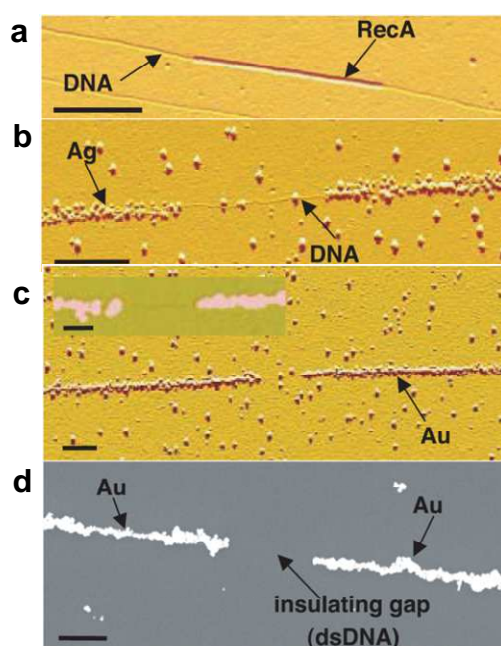

Figure 1.4: Sequence-specific lithography and metallization of dsDNA substrates. **a**, AFM image of recombined nucleoprotein filament. **b**, AFM image after silver aggregation. **c**, AFM image after gold metallization of silver coated dsDNA fragments. **d**, SEM image after gold metallization of silver aggregated dsDNA fragments.²⁵

Equally, in 2005 *Yashima et al.* also applied the sequence-specific gab formation during metallization of dsDNA using a RecA-ssDNA filament as protective group.²⁶ In contrast to the work of *Braun et al.*, two different RecA proteins were applied, one unmodified wild-type (WT) RecA and one RecA protein modified with a cysteine at the C-terminus (Cys-RecA). In previous studies it was demonstrated that both, WT- and Cys-RecA, exhibit the same activity regarding the formation of nucleoprotein filaments.^{105,106} But the genetically engineered Cys-RecA protein was expected to have higher labeling efficiency during gold deposition

using monomaleimido nanogold, while the function of WT-RecA was the non-covalent protection during the metallization process.²⁶ As shown in Figure 1.5a, nucleoprotein filament existing of ssDNA and WT-RecA was applied as sequence-specific protective group for a dsDNA substrate. In a second step, the WT-RecA-ss/dsDNA complex was incubated with Cys-RecA enabling nucleoprotein formation with dsDNA fragments which are not in contact with WT-RecA. As shown in Figure 1.5b, the following treatment of the filament with activated gold particles resulted in the introduction of gold only at Cys-RecA proteins, while the fragment complexed with WT-RecA showed no reactivity. Hence, the subsequent metallization resulted in a 25 μm long gold nanowire with a gap of 1 μm length.²⁶

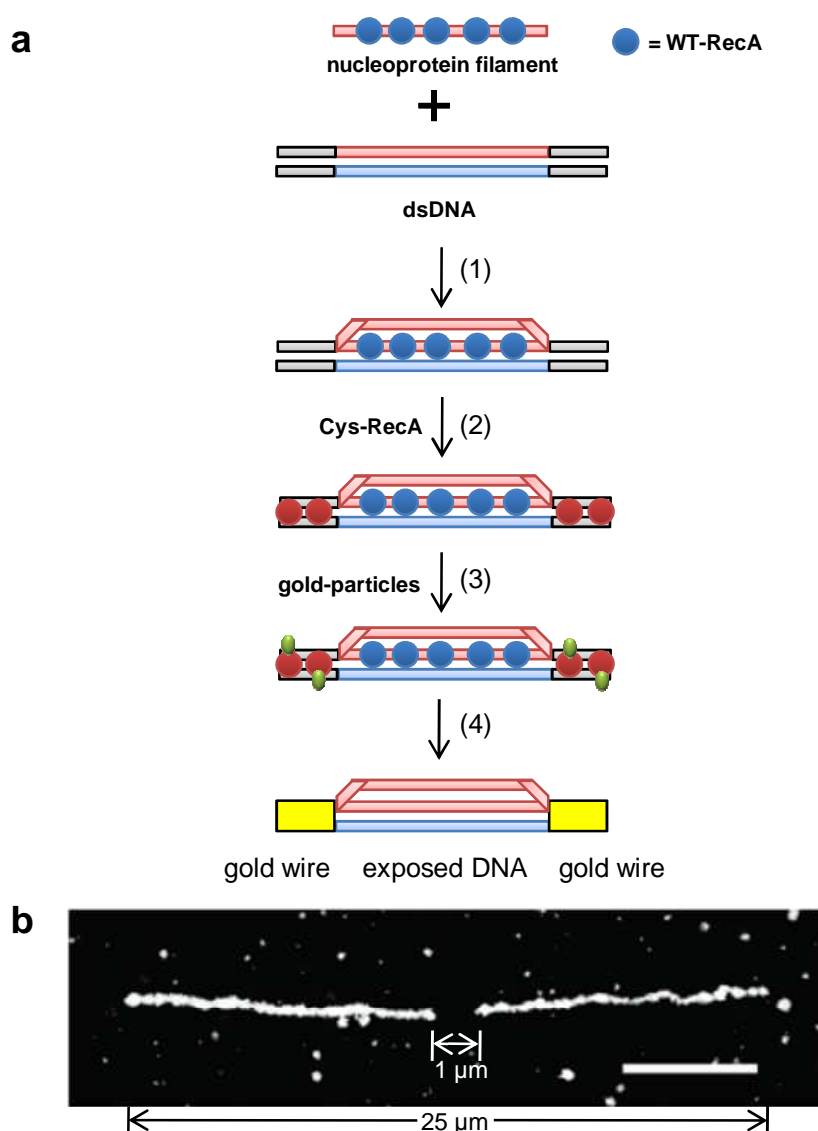

Figure 1.5: **a**, Sequence-specific gap formation employing WT-RecA as protective group and Cys-RecA as a scaffold for metallization: Homologous recombination (1), nucleoprotein filament formation with Cys-RecA (2), coupling of gold-nanoparticles to cystein residues of Cys-RecA protein (3) and gold metallization (4). **b**, SEM image after gold metallization.²⁶

1.6 Motivation and Thesis Overview

After describing several non-covalent protection strategies enabling the modification of multifunctionalized compounds, in the following the motivation and overview of my thesis are given.

Modification of synthetic and natural compounds is a general tool to obtain molecular structures with different physical, chemical and biological properties. For example, transformation of organic dyes, which are widely applied in solar cells, changes their optical properties and electron-transfer abilities. The substitution of side groups of conductive polymers results in materials with different electrical and optical properties. And conjugation of diverse molecular architectures allows the combination of different properties resulting in new materials. Moreover, the modification of synthetic and natural product is especially a well established tool in the drug discovery and development process. For example, selective modifications of known therapeutics are utilized to overcome anti-drug resistance, increase their efficiency, decrease toxicity and find new indications. However, to obtain a compound with defined characteristics, often site-specific diversifications are necessary. But due to the fact that most molecules exhibit several functional groups with similar or equal chemical reactivity, these regioselective transformations are limited. The reaction of multifunctionalized compounds results often in a mixture of inseparable regioisomers. Therefore, selective modification of structurally complex molecules requires laborious and time consuming part- and total synthesis. That for example is an important reason why potential drug candidates exhibiting a complex molecular structure are excluded from the drug development process in pharmaceutical industries. To simplify the regioselective modification and facilitate the development of compounds with new properties, much effort has been devoted to the development of one-step derivatization methods on the level of the multifunctional molecules. Hence, in **chapter 1** several strategies are described, which enable the regioselective transformation of many natural and synthetic compounds in only one reaction step. All the reported methods have the application of non-covalent protective groups in common. These protective groups, based on metal-chelate complexes, macrocycles, polymer conjugates and enzymes, allow site-specific protection of several functionalities of a molecule, while functional groups not in contact with the protective group can be transformed regioselectively. Another advantage of these introduced supramolecular protective groups (SPGs) is their easy introduction and removal due to the non-covalent interaction with the compound to be modified. Moreover, the application of this protection strategy facilitates the

synthesis of a broad spectrum of derivatives of a multifunctionalized compound. However, most of the introduced SPGs exhibit several limitations in order to be applied in industrial drug discovery process: Non-covalent protective groups based on macrocycles require extensive design and synthesis, and can bind only to small compounds exhibiting two functional groups; enzymes have a limited number of substrates they can interact with; and the application of metals in drug synthesis is often restricted and has to be minimized due to their toxicity.

To overcome these limitations of existing non-covalent protective groups and at the same time benefit from their advantageous specific non-covalent interactions the work presented in this thesis is focused on the development of a new supramolecular protection strategy. In this work short ribonucleic acid sequences (RNA aptamers) are applied as non-covalent **aptameric protective groups (APGs)** for structurally complex aminoglycoside antibiotics. RNA aptamers are particularly very well suited as non-covalent protective groups, since nucleic acids can act as ligand (host) for a broad range of guest molecules of different structural complexity with high affinity and specificity. A further advantage is that they can be evolved through a well established selection process in few weeks and are produced by automated synthesis. In **chapter 2**, the applicability of three different RNA sequences as APGs is described for the regioselective modification of neamine antibiotic neomycin B exhibiting six amino- and seven hydroxy groups of similar reactivity. For modification of neomycin B acylation of amino groups was applied using *N*-hydroxy succinimide (NHS) esters of different size. Furthermore, it was investigated if an APG, which was generated for neomycin B, can also be utilized as non-covalent protective group for aminoglycosides with a related pharmacophore. Hence, an APG selected against neomycin B was tested for the regioselective modification of the antibiotic paromomycin.

Since the presence of more than one binding site within one RNA aptamers (APG) can result in different protection modes for the guest molecule and therefore, can limit the regioselectivity of the modification reaction, the mode of action of APGs was elucidated in **chapter 3**. First, the number and the affinity of binding sites of different APGs for neomycin B were determined using **Isothermal Titration Calorimetry (ITC)**. Afterwards, the mode of protection of each binding site was resolved by modification of neomycin B applying different conditions for the acylation reaction with NHS ester. Hence, the influence of the complex stability between antibiotic and APGs, reaction time and antibiotic/APG ratio on the regioselectivity was investigated. These parameters are particularly essential in order to

maximize the regioselectivity of the modification of the guest molecule and to verify the applicability of APGs under different conditions, such as various temperatures and varying salt concentration.

After these proof-of-concept studies demonstrating the feasibility of the use of RNA aptamers as non-covalent protective groups, in **chapter 4** the new concept is further exploited. To establish the introduced APG methodology as a general tool in organic synthesis different reactions are tested for the regioselective modification of the antibiotics neomycin B and paromomycin. First, different acylation reactions were tested using negatively charged activated esters, such as sulfo-NHS ester and 4-sulfo-*tetra*-fluorophenyl (STP) ester, to enable the introduction of more hydrophobic residues in the antibiotic neomycin B. This is particularly important, since the complex formation between APG and antibiotic is performed in aqueous buffer solution, which is a limiting factor regarding the utilization of hydrophobic reagents. Furthermore, the regioselective introduction of azide- and sulfhydryl groups was investigated using the azide-transfer reagent imidazolyl-1-sulfonyl azide and the thiolation reagent 2-iminothiolane, respectively. The regioselective diazotation and thiolation of the APG-protected compound have the advantage that they allow further modifications in an additional step without the use of APGs resulting in a broad spectrum of accessible derivatives. To exploit further the feasibility of the APG-methodology, modifications of different functionalities of neomycin B was investigated in presence of APG. Hence, urea bond formation using aliphatic and aromatic isocyanates was performed enabling a chemo- and regioselective modification of another amino group then described in previous chapters. Moreover, it was demonstrated that the APG strategy also allows chemo- and regioselective *di*-functionalization of neomycin B employing urea bond formation and azide introduction.

Besides introducing the APG strategy for the regioselective modification of neamine antibiotics neomycin B and paromomycin, the work in **chapter 5** describes the regioselective modification of neamine antibiotics in a single synthetic step without the use of non-covalent protective groups. It is well known that the neamine moiety of these antibiotics is essential for their antibacterial activity but at the same time this structural unit is also the main target of many resistance mechanisms in bacteria. Therefore, the modification of this part of the molecule is a very promising strategy to overcome antibacterial resistance and/or increase antibiotic activity. With this motivation in mind, a pH-dependent regioselective azide introduction at the 2-desoxystreptamine ring of diverse neamine antibiotics was demonstrated using the diazo-transfer reagent imidazolyl-1-sulfonyl azide in a buffered aqueous solution.

This strategy was tested employing neamine antibiotics neomycin B, paromomycin, ribostamycin, amikacin and apramycin and neamine as substrates.

In the following chapters, a more detailed description of the above mentioned new strategies for the modification of neamine antibiotics will be given.

1.7 References

- 1 Koehn, F. E., Carter, G. T. The evolving role of natural products in drug discovery. *Nature* **4**, 206-220 (2005).
- 2 Jesse, W.-H., Vederas, J. C. Drug discovery and natural products: End of an Era or an Endless Frontier. *Science* **325**, 161-165 (2009)
- 3 Mangina, A. Process for the synthesis of amikacin. US Patent 5.763.587 (1998).
- 4 Iseman M.D. A clinician's guide to tuberculosis. *Lippincott-Williams and Wilkins Philadelphia*, 323-353 (2000).
- 5 Caminero, J. A., Sotgiu G., Zumla A., Migliori, G. B. Best drug treatment for multidrug-resistant and extensively drug-resistant tuberculosis. *Lancet Infect. Diseases***10**, 621-629 (2010).
- 6 Chan, H.-Y., Grossman, A. B., Bukowski, R. M. Everolimus in the treatment of renal cell carcinoma and neuroendocrine tumors. *Adv. Ther.* **27**, 495-511 (2010).
- 7 Arbuzova, A. et al. Fluorescently labeled neomycin as a probe of phosphatidylinositol-4,5-bisphosphate in membranes. *Biochimica et Biophysica Acta* **1464**, 35-48 (2000).
- 8 Borkow, G., Vijayabaskar, V., Herman Lara, H., Kalinkovich, A., Lapidot, A. Structure–activity relationship of neomycin, paromomycin, and neamine–arginine conjugates, targeting HIV-1 gp120-CXCR4 binding step. *Antiviral Research* **60**, 181-192 (2003).
- 9 Alper, P. B., Hendrix, M., Sears, P. & Wong, C. H. Probing the specificity of aminoglycoside ribosomal RNA interactions with designed synthetic analogs. *J. Am. Chem. Soc.* **120**, 1965-1978 (1998).
- 10 González-Sabín, J., Morán-Ramallal, R., Rebolled, F. Regioselective enzymatic acylation of complex natural products: Expanding molecular diversity. *Chem. Soc. Rev.* **40**, 5321-5335 (2011).
- 11 Green, K. D., Chen, W., Houghton, J. L. Fridman, M., Garneau-Tsodikova, S. Exploring the substrate promiscuity of drug-modifying enzymes for the chemoenzymatic generation of N-acylated aminoglycosides. *Chem. Bio. Chem.* **11**, 119-126 (2010).
- 12 Weissman, K. J., Rolf Müller, R. Protein-protein interactions in multienzyme megasynthetases. *Chem. Bio. Chem.* **9**, 826 – 848 (2008).
- 13 Lee, A. H., Cheong, C. S. Selective reactions of reactive amino groups in polyamino compounds by metal-chelated or –mediated methods. *Tetrahedron* **57**, 4801-4815 (2001).
- 14 Moon, M. S., et al. Synthesis and spectrum of the neoglycoside ACHN-490. *Antimicrob. Agents Chemother.* **54**, 4636-4642 (2010).

- 15 Nudelman, I. et al. Development of novel aminoglycoside (NB54) with reduced toxicity and enhanced suppression of disease-causing premature stop mutations. *J. Med. Chem.* **52**, 2836-2845 (2009).
- 16 Burguete, M. I., Escuder, B., S. V. Luis, Miravet, J. F. Selective monofunctionalization of polyaza[n]paracyclophanes. *Tet. Lett.* **35**, 9075-9078 (1994).
- 17 Burguete, M. I., An efficient preparation of ditopic receptors based on polyaza[n]cyclophanes. *Chem. Comm.* **17**, 1823-1824 (1998).
- 18 Cafeo, G., Kohnke, F. H., Valenti, L. Regioselective O-alkylations and acylations of polyphenolic substrates using a calix[4]pyrrole derivative. *Tetrahedron Letters* **50**, 4138-4140 (2009).
- 19 Coquiere, D., de la Lande, A., Parisel, O., Prange, T. & Reinaud, O. Directional control and supramolecular protection allowing the chemo- and regioselective transformation of a triamine. *Chem.-Eur. J.* **15**, 11912-11917 (2009).
- 20 Hyde, C. B., Mascagni, P., The use of crown ethers in peptide chemistry: Part 3, synthesis of an enkephalin derivative using 18-crown-6 as a non-covalent amino protective group. *Tetrahedron* **31**, 399-402 (1990).
- 21 Mascagni, P. et al. The use of crown ether in peptide chemistry IV. Solid phase synthesis of peptides using peptide fragments Na protected with 18-crown-6. *Tetrahedron* **51**, 5447-5458 (1995).
- 22 Wilrd, G. P., Wiles, C., Watts, P., Haswell, S. J. The use of immobilized crown ether as in-situ N-protecting groups in prganic synthesis and their application under continuous flow. *Tetrahedron* **65**, 1618-1629 (2009).
- 23 Schiavon, O., Caliceti, P., Ferruti, P., Veronese, F. M. Therapeutic proteins: A comparison of chemical and biological properties of uricase conjugated to linear or branched poly(ethylene glycol) and poly(N-acryloylmorpholine). *Il Farmco* **55**, 264-269 (2000).
- 24 Caliceti, P., Schiavon, O., Sartore, L., Monfardini, C., Veronese, F. M. Active site protection of proteolytic enzymes by poly(ethylene glycol) surface modification. *J. of Bioactive and Compatible Polymers* **8**, 41-49 (1993).
- 25 Keren, K., Krueger, M., Gilad, R., Ben-Yoseph, G., Sivan, U., Braun, E. Sequence-specific molecular lithography on single DNA molecules. *Science* **297**, 72-75 (2002).
- 26 Yashima et al. Conductive metal nanowires templated by the nucleoprotein filaments, complex of DNA and RecA protein. *J. Am. Chem. Soc.* **127**, 8120-8125 (2005).
- 27 Dozzo, P., Moser, H. E. New aminoglycoside antibiotics. *Expert Opin. Ther. Patents* **20**, 1321-1341 (2010).
- 28 Kang, S.-J., Kim, D-H., Mishig-Ochir, T., Lee, B.-J. Antimicrobial peptides: Their physicochemical properties and therapeutic application. *Arch. Pharm. Res.* **35**, 409-413 (2012).
- 29 Prester, L. Biogenic amines in fish, fish products and shellfish: A review. *Food additives and contaminants part A-chemistry analysis control exposure & risk assessment* **28**, 1547-1560 (2011).
- 30 Mewis, R. E., Archibald, S. J. Biomedical applications of macrocyclic ligand complexes. *Coordin. Chem. Rev.* **254**, 1686-1712 (2010).
- 31 Moon M. S., et al. A semisynthesis of isepamicin by fragmentation method. *Tet. Lett.* **46**, 607-609 (2005).

Chapter 1

- 32 Xie, J., Talaska, A. E., Schacht, J., New developments in aminoglycoside therapy and ototoxicity. *Hearing Res.* **281**, 28-37 (2011).
- 33 Lapidot, A., Brechanski, A., Borkow, G. Insight into the mechanisms of aminoglycoside derivatives interaction with HIV-1 entry steps and viral gene transcription. *FEBS J.* **275**, 5236-5257 (2008).
- 34 Zhou, J., Wang, G., Zhang, L.-H., Ye, X.-S. Modifications of aminoglycoside antibiotics targeting RNA. *Med. Res. Rev.* **27**, 279-316 (2007).
- 35 Yang, L., Ye, X.-S. Development of aminoglycoside antibiotics against resistant bacterial strains. *Curr. Topics in Med. Chem.* **10**, 1898-1926 (2010).
- 36 Busscher, G. F., Rutjes, F. P. J. T., van Delft, F. L. 2-Desoxystreptamine: Central scaffold of aminoglycoside antibiotics. *Chem. Rev.* **105**, 775-791 (2005).
- 37 Haddad, J. et al. Design of novel antibiotics that bind to ribosomal acyltransfer site. *J. Am. Chem. Soc.* **124**, 3229-3237 (2002).
- 38 Nagabhushan, T. et al., Interaction of vicinal and nonvicinal amino-hydroxy group pairs in aminoglycoside-aminocyclitol antibiotics with transition metal cations. Selective N-protection. *J. Am. Chem. Soc.* **100**, 5253-5254 (1978).
- 39 Hanessioan, S. Patil, G. Aminoglycoside antibiotics – a method for selective N-acylation based on the temporary protection of amino alcohol functions as copper chelates. *Tet. Lett.* **12**, 1035-1038 (1978).
- 40 Broddefalk, J. et al. T Cells Recognize a Glycopeptide Derived from Type II Collagen in a Model for Rheumatoid Arthritis. *J. Am. Chem. Soc.* **120**, 7676-7683 (1998).
- 41 Broddefalk, J., Forsgren, M., Sethson, I., Kihlberg, J. Preparation of a diglycosylated hydroxylysine building block used in solid-phase synthesis of a glycopeptide from Type II Collagen. *J. Org. Chem.* **64**, 8948-8953 (1999).
- 42 Adamczyk, M., Johnson, D. D., Reddy, R. E. Bone collagen cross-links: An efficient one-pot synthesis of (+)-pyridinoline and (+)-deoxypyridinoline. *Tetrahedron: Asymmetry* **11**, 228-2298 (2000)
- 43 Albericio, F. et al. Convenient synthesis of fluorenylmethyl-based side chain derivatives of glutamic and aspartic acids, lysine, and cysteine. *Synthesis*, 119-122 (1990).
- 44 Kimura, E. Macrocyclic polyamines with intelligent function. *Tetrahedron* **48**, 6175-6217 (1992).
- 45 Alexander, V. Design and synthesis of macrocyclic ligands and their complexes of lanthanides and actinides. *Chem. Rev.* **95**, 273-342 (1995).
- 46 Cox, J. P. L. et al. Synthesis of kinetically stable yttrium-90 labeled macrocycle-antibody conjugate. *J. Chem. Soc. Chem. Comm.*, 797-798 (1989).
- 47 Kimura et al. Carboxyester hydrolysis promoted by a new Zn(II) macrocyclic triamine complex with an alkoxide pendant: A model study for the serine alkoxide nucleophile in Zinc enzymes. *J. Am. Chem. Soc.* **116**, 4764-4771 (1994).
- 48 Sessler, J. L., Sibert, J. W. On the synthesis of unsymmetrical bis(macrocyclic) ligands. *Tetrahedron* **49**, 8727-8738 (1993).
- 49 Mallik, S., Johnson, R. D., Arnold, F. H. Synthetic bis-metal ion receptors for bis-imidazole "protein analogs". *J. Am. Chem. Soc.* **116**, 8902-8911 (1994).
- 50 Kimura, E., Aoki, S., Koike, T., Shiro, M. A tris(Zn^{II}-1,4,7,10-tetraazacyclodecane) complex as a new receptor for phosphate dianions in aqueous solution. *J. Am. Chem. Soc.* **119**, 3068-3076 (1994).

- 51 Filali, A., Yaouanc, J.-J., Handel, H. Stoichiometric mono *N*-functionalization of tetraazamacrocycles via phosphoryl-protected intermediates. *Angew. Chem., Int. Ed. Engl.* **30**, 560-561 (1991).
- 52 Parker, D., Senanayake, Williams, J. A. G. Luminescent chemosensors for pH, halide and hydroxide ions based on kinetically stable, macrocyclic europium -phenanthridinium conjugates. *Chem. Comm.*, 1777-1778 (1997).
- 53 Kaden, T. A. Synthesis and metal complexes of aza-macrocycles with pendant arms having additional ligating groups. *Top. Curr. Chem.* **121**, 157-179 (1984).
- 54 Krakowiak, K. E., Bradshaw, J. S., Izatt, R. M. Preparation of triaza-, tetraaza- and peraza-crown compounds containing aminoalkyl side groups or unsubstituted ring nitrogen atoms. *J. Org. Chem.* **55**, 3364-3368 (1990).
- 55 Bridger, G. J. Research article synthesis and structure-Activity relationships of phenylenebis(methylene)-Linked bis-tetraazamacrocycles that inhibit HIV replication. Effects of macrocyclic ring size and substituents on the aromatic linker. *J. Med. Chem.* **38**, 366-378 (1995).
- 56 Abrams, H., C. Synthesis and structure-activity relationships of phenylene-bis(methylene)- linked bis-tetraazamacrocycles that inhibit human immunodeficiency virus replication. 2. effect of heteroaromatic linkers on the activity of bicyclams. *J. Med. Chem.* **39**, 109-119 (1996).
- 57 Casnati, A. Calixarenes: From chemical curiosity to a rich source for molecular receptors. *Gazz. Chim. Ital.* **127**, 637-649 (1997).
- 58 Gokel, G. W., Leevy, W. M. Weber, M. E. Crown ethers: Sensors for ions and molecular scaffolds for materials and biological models *Chem. Rev.* **104**, 2723-2750 (2004).
- 59 Zhao, W., Zhong, Q. Recent advance of cyclodextrins as nanoreactors in various organic reactions: A brief overview. *J. Incl. Phenom. Macrocycl. Chem.* **72**, 1-14 (2012).
- 60 Cafeo, G. et al. Efficient organocatalysis with a calix[4]pyrrole derivative. *Tet. Lett.* **49**, 153-155 (2007).
- 61 Sansone, F., Baldini, L., Casnati, A., Ungaro, R. Calixarenes: From biomimetic receptors to multivalent ligands for biomolecular recognition. *New J. Chem.* **34**, 2715-2728 (2010).
- 62 Hartman, G. D. et al. Non-peptide fibrinogen receptor antagonists. 1. Discovery and design of exosite inhibitors. *J. Med. Chem.* **35**, 4640-4642 (1992).
- 63 Chung, J. Y. L., Zhao, D., Hughes, D. L., Grabowski, E. J. J. A practical synthesis of fibrinogen receptor antagonist MK-383. selective functionalization of (S)-tyrosine. *Tetrahedron* 1993 **49**, 5767-5776 (1993).
- 64 Aikins, J. A. et al. Synthesis of a peroxime proliferator activated receptor (PPAR) α/γ agonist via stereocontrolled williamson ether synthesis and stereospecific S_N2 reaction of *S*-2-chloro propionic acid with phenoxides. *J. Org. Chem.* **70**, 4695-4705 (2005).
- 65 Rotella, D. P. et al. Optimization of substituted *N*-3-benzylimidazoquinazolinone sulfonamides as potent and selective PDE5 inhibitors. *J. Med. Chem.* **43**, 5037-5043 (2000).
- 66 Xu, G., Hartman, T. L., Wargo, H., Turpin, J. A., Buckheit, R. W., Cushman, M. Synthesis of alkenyldiarylmethane (ADAM) non-nucleoside reverse transcriptase inhibitors with non-identical aromatic rings. *Bioorg. Med. Chem.* **10**, 283-290 (2002).
- 67 Tillekeratne, L. M. V., Sherette, A., Grossman, P., Hupe, L., Hupe, D., Hudson, R. A. Simplified catechin-gallate inhibitors of HIV-1 reverse transcriptase. *Bioorg. Med. Chem. Lett.* **11**, 2763-2767 (2001).

Chapter 1

- 68 Rivero-Cruz, I. et al. Antimycobacterial agents from selected Mexican medicinal plants. *J. Pharm. Pharmacol.* **5**, 1117–1126 (2005).
- 69 Andries, K. et al. A Diarylquinoline Drug Active on the ATP Synthase of Mycobacterium tuberculosis. *Science* **307**, 223–227 (2005).
- 70 Lewin, A. H., Szewczyk, J., Wilson, J. W., Carroll, F. I. Galanthamine analogs: 6*H*-Benzofuro[3*a*,3,2-*e,f*][1]benzazepine and 6*H*-benzofuro[3*a*,3,2-*e,f*][3]benzazepine. *Tetrahedron* **61**, 7144–7152 (2005).
- 71 Penso, M., Albanese, D., Landini, D., Lupi, V., Scaletti, D. Chemoselective N-alkylation of di-N,O-protected tyrosine through specific oxy-anion solvation by non-hydrogen bonding donor solvents. *Synlett* 741–744 (2006).
- 72 Casimir, J. R., Tourwe, D., Iterbeke, K., Guichard, G., Briand, J. P. Efficient synthesis of (*S*)-4-phthalimido-1,3,4,5-tetrahydro-8-(2,6-dichlorobenzyloxy)-3-oxo-2*H*-2-benzazepin-2-acetic acid (Pht-Hba(2,6-Cl₂-Bn)-Gly-OH). *J. Org. Chem.* **65**, 6487–6492 (2000).
- 73 Eicher, T., Ott, M., Speicher, A. New syntheses of rosmarinic acid and related compounds. *Synthesis* **6**, 755–762 (1996)
- 74 Guo, W., Li, J., Fan, N., Wu, W., Zhou, P., Xia, C. A simple and effective method for chemoselective esterification of phenolic acids. *Synth. Commun.* **35**, 145–152 (2005).
- 75 Liu, P., Huang, L., Faul, M. M. A simple method for chemoselective phenol alkylation. *Tet. Lett.* **48**, 7380–7382 (2007).
- 76 Faber, K. *Biotransformations in Organic Chemistry 5th ed.*; Springer: Berlin, 94–123 (2004).
- 77 Gais, H. J., Theil, F. *In Enzyme Catalysis in Organic Syntheses*. Drauz, K., Waldmann, H., Eds., **2nd ed.**; Wiley-VHC: Weinheim, 335–578 (2002).
- 78 Miyazawa, T., Hamada, M., Morimoto, R., Murashima, T., Yamada, T. Highly regioselective propanoylation of dihydroxybenzenes mediated by *Candida antarctica* lipase B in organic solvents. *Tet. Lett.* **49**, 175–178 (2008).
- 79 Ciuffreda, P., Casati, S., Santaniello, E. Regioselective hydrolysis of diacetoxynaphthalenes catalyzed by *Pseudomonas* sp. lipase in an organic solvent. *Tetrahedron* **56**, 317–321 (2000).
- 80 Cafeo, G., Kohnke, F. H., Valenti, L., White, A. J. P. pH-Controlled molecular switches and the substrate-directed self-assembly of molecular capsules with a calix[4]pyrrole derivative. *Chem. Eur. J.* **14**, 11593–11600 (2008).
- 81 O. Sénèque, O. Rager, M. N., Giorgi, M., Reinaud, O. Calix[6]arenes and zinc: Biomimetic receptors for neutral molecules. *J. Am. Chem. Soc.* **122**, 6183–6189 (2000).
- 82 Rondelez, Y., Bertho, G., Reinaud, O. The first water-soluble copper(I) calix[6]arene complex presenting a hydrophobic ligand binding pocket: A remarkable model for active sites in metalloenzymes. *Angew. Chem. Int. Ed.* **41**, 1044–1046 (2002).
- 83 Rondelez, Y., Rager, M. N., Duprat, A., Reinaud, O. Calix[6]arene-based cuprous “funnel complexes”: A mimic for the substrate access channel to metalloenzyme active sites. *J. Am. Chem. Soc.* **124**, 1334–1340 (2002).
- 84 Coquière, D., Marrot, J., Reinaud, O. Spectacular induced-fit process for guest binding by a calix[6]arene Zn(II) funnel complex. *Org. Biomol. Chem.* **6**, 3930–3934 (2008).

- 85 Coquière, D., Marrot, J. Reinaud, O. Encapsulation of a $(\text{H}_3\text{O}_2)^-$ unit in the aromatic core of a calix[6]arene closed by two Zn(II) ions at the small and large rims. *Chem. Commun.* 3924-3926 (2006).
- 86 Coquière, D., de la Lande, A., Martí, S., Parisel, O., Prangé, T. Reinaud, O. Molecular Recognition and Self-Assembly Special Feature: Multipoint molecular recognition within a calix[6]arene funnel complex. *Proc. Natl. Acad. Sci. USA* **106**, 10449- 10454 (2009).
- 87 Pedersen, C.J. Cyclic polyethers and their complexes with metal salts. *J. Am. Chem. Soc.* **89**, 2495-3006 (1967).
- 88 Buschmann, H.-J., Mitihac, L. Complexation, liquid-liquid extraction, and transport through a liquid membrane of protonated peptides using crown ethers. *Anal. Chim. Acta* **466**, 101-108 (2002).
- 89 Batinic-Haberele, I., Crumbliss, A. L., Spasojevic, I., Bartsch, R. A. Stereochemical factors affecting 2nd-Sphere coordination of ferrioxamine-B with cis-syc-cis and scis-anti-cis isomers of dicyclohexano-18-crown-6 in chloroform and a comparison with alkali-metak abd ammonium cations. *J. Chem. Soc., Dalton Trans.* 2503 (1995).
- 90 Kunishima, M., Hioki, K., Moriya, T., Morita, J., Ikuta, T., Tani, S. Primary-amine-specific lactamization of omega-amino acids by an artificial cyclotransferase based on [18]crown-6. *Angew. Chem., Int. Ed.* **45**, 1252-1255 (2006).
- 91 Nucci, M.L., Shorr, R., Abuchowski A. The therapeutic value of poly(ethylene glycol)-modified proteins. *Adv. Drug Delivery Rev.* **6**,133-151 (1991).
- 92 Delgado, C., Francis, G.E., Derek, F.F. The uses and properties of PEG-linked proteins. *Critical Rev. Ther. Drug Carrier Syst.* **9**, 249-304 (1992).
- 93 Katre, N.V. The conjugation of proteins with polyethylene glycol and other polymers. Altering properties of proteins to enhance their therapeutic potential. *Adv. Drug Delivery Rev.* **10**, 91-114 (1993).
- 94 Dreborg, S., Akerblom, E. B., Immunotherapy with monomethoxy polyethylene glycol modified allergens. *Critical Rev. Ther. Drug Carrier Syst.* **6**, 315-365 (1990).
- 95 Chua, C. C., Greenberg, M. L., Vian, A. T., Nucci, M., Brenckman, W. D., Hershfield, M. S. Use of polyethyleneglycol-modified uricase (PEG-Uricase) to treat hyperuricemia in a patient with non-Hodgkin lymphoma. *Ann. Int. Med.* **109**, 114-117 (1988).
- 96 Abuchowski, A., Karp, D., Davis, F. F. Reduction of plasma urate level in the cockerel with polyethylene glycol-uricase, *J. Pharmacol. Exp. Ther.* **219**, 352-354 (1981).
- 97 Davis, S., Park, Y. K., Abochowski, A., Davis, F. F. Hypouricaemic effect of polyethyleneglycol modified urate oxidase, *Lancet* **2**, 281-283 (1981).
- 98 Brogard, J. M., Stahl, A., Stahl, J. Enzymatic uricolysis and its use in therapy. Kelley, W. N., Arnold, W. J., Weiner, I. M. (Eds.), *Uric Acid - Handbook of Experimental Pharmacology*, vol. **51**, Springer, New York, 515-524 (1978).
- 100 Braun, E., Eichen, Y., Sivan, U., Ben-Yoseph, G. DNA-templated assembly and electrode attachment of a conducting silver wire. *Nature* **391**, 775-778 (1998).
- 101 Eichen, Y., Braun, E., Sivan, U., Ben-Yoseph, G. Self-assembly of nanoelectronic components and circuits using biological templates. *Acta Polym.* **49**, 663-670 (1998).
- 102 Cox, M. M., Lehman, I. R. Enzymes of general recombination. *Annu. Rev. Biochem.* **56**, 229-262 (1987).

Chapter 1

- 103 Radding, C. M. Helical RecA nucleoprotein filaments mediate homologous pairing and strand exchange. *Biochim. Biophys. Acta* **1008**, 131-145 (1989).
- 104 Roca, A. I., Cox, M. M. RecA protein: Structure, function, and role in recombinational DNA repair. *Prog. Nucleic Acid Res. Mol. Biol.* **56**,129-223 (1997).
- 105 Egelman, E. H., Stasiak, A. Structure of helical RecA-DNA complexes. Complexes formed in the presence of ATP-gamma-S or ATP. *J. Mol. Biol.* **191**, 677-697 (1986).
- 106 Stasiak, A., Egelman, E. H. Structure and function of RecA-DNA complexes. *Experientia* **50**, 192-203 (1994).

Chapter 2

Aptameric Protective Groups for One-Step Modification of Aminoglycoside Antibiotics

(Part of this chapter is published online:

A. A. Bastian, A. Marcozzi, A. Herrmann. *Nature Chemistry* **4**, 1-5 (2012))

(Based on this chapter a European patent is filed: A. A. Bastian, A. Marcozzi, A. Herrmann 2011)

Emerging trends in drug discovery are prompting a renewed interest in natural products as source of chemical diversity and lead structures. However, due to the structural complexity of many natural compounds the synthesis of derivatives is not easily realized. Here, we demonstrate a conceptually new approach using oligonucleotides as aptameric protective groups (APGs). APGs block several functionalities by non-covalent interactions in a complex molecule and enable the highly chemo- and regioselective derivatization (98 %) of natural antibiotics in a single synthetic step with good conversions of up to 71 %. This technique should help to accelerate the discovery of new biologically active structures while avoiding costly and cumbersome synthetic routes.

2.1 Introduction

Very recently, natural products have experienced a renaissance in drug discovery. This trend is rationalized by a growing number of new natural sources, improved separation methods and characterization techniques.^{1,2} Another reason for the high interest in natural products is the better chance of finding a desirable bioactivity due to their natural scaffolds.^{1,2} However, these frameworks are very often structurally complex exhibiting several chemical equivalent functionalities. Thus, regioselective modification of these molecular architectures is restricted to the application of genetically modified organisms^{1,2} and extensive semi- or total synthesis.^{3,4,5} The latter route is very often characterized by several protection and deprotection steps to modify specific functional groups or sites of the target molecule. A much simpler process to enable selective derivatization of complex natural products would be the introduction of macromolecular protective groups directly at the level of these compounds. Due to their extended size they can in parallel protect several functionalities of the natural product by non-covalent interactions while other groups not involved in binding can be specifically reacted.

To test the feasibility of this approach, in the present study RNA aptamers were introduced as non-covalent **aptameric protective groups (APGs)**. As a promising class of compounds with high affinity, specificity and stability, RNA and DNA molecules are particularly well suited as APGs, as they can act as ligands for a wide variety of low molecular weight compounds and macromolecular architectures,^{6,7} can be evolved through the well established *in vitro* evolution process SELEX^{8,9} (**S**ystematic **E**volution of **L**igands by **E**Xponential **E**nrichment) and can be produced by automated synthesis. Out of the aptamers that were generated against amino acids,^{10,11} nucleotides,¹² organic dyes,⁸ porphyrin derivatives,¹³ proteins,¹⁴ hydrophobic lipids¹⁵ and aminoglycoside antibiotics,^{16,17,18} we chose aptamers for the latter class of compounds. Aminoglycosides offer a particularly attractive test for regioselective derivatization using APGs, since modification of antibiotics based on carbohydrates targeting prokaryotic 16S ribosomal RNA (rRNA)^{18,19,20} have become a powerful tool against drug-resistant bacteria.^{21,22} Important examples based on the neamine scaffold are the neamine antibiotics neomycin **1** and paromomycin **2** (Fig. 2.1a).

2.2 Results & Discussion

2.2.1 Regioselective Acylation of Neomycin B Employing RNA as APG

For a straightforward proof of concept that RNA can act as an APG, a well characterized aptamer-aminoglycoside complex was chosen: 23mer RNA aptamer (sequence: 5'-GGA CUG GGC GAG AAG UUU AGU CC-3', **apt1**, Fig. 2.1b) and neomycin B (Fig. 2.1a)²³. X-ray crystallography and nuclear magnetic resonance (NMR) measurements revealed that ring IV of guest molecule **1** is not involved in complex formation and extends into the solvent (Fig. 2.1c).¹⁶

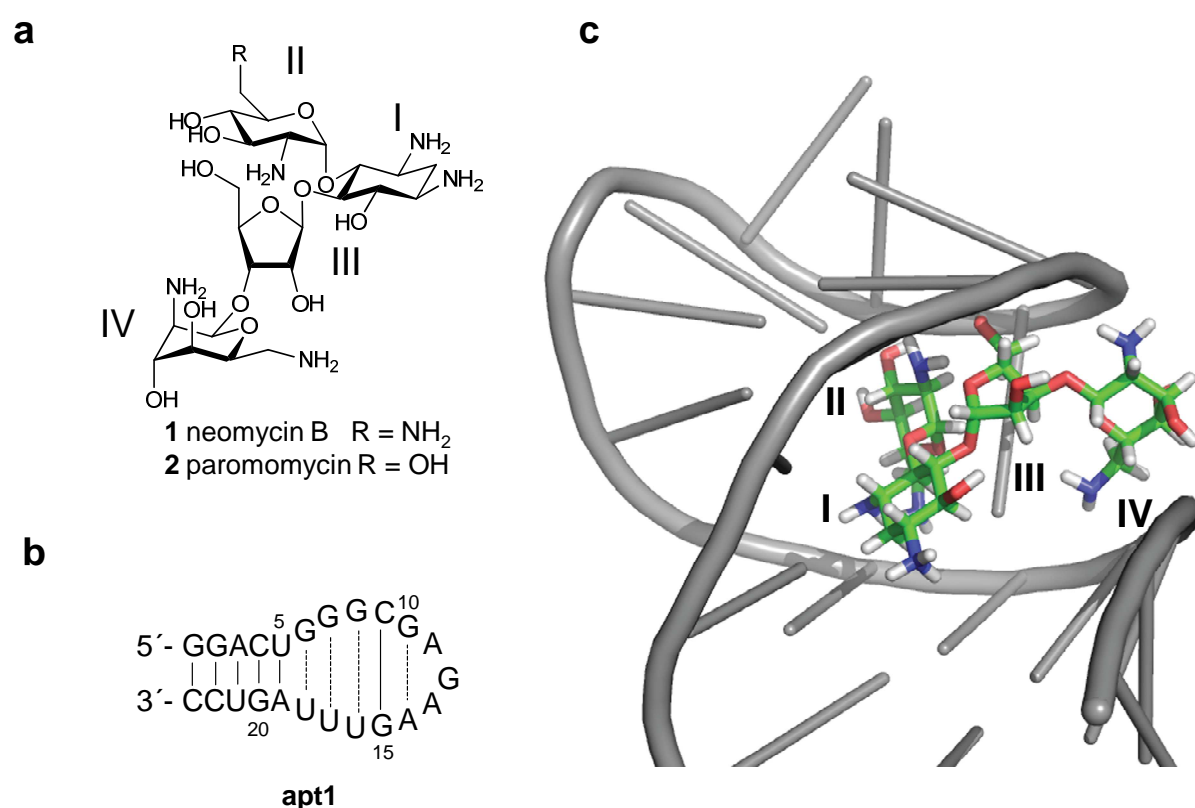

Figure 2.1: **a**, Structure of representative aminoglycoside antibiotics. **b**, Stem-loop structure of APG **apt1**. **c**, **Apt1** selectively protecting neomycin B¹⁶ (Color coding: white - hydrogen; green - carbon; red - oxygen; blue - nitrogen).

As shown in Figure 2.2a, we choose the acylation reaction employing *N*-hydroxysuccinimide (NHS) ester **3a-c** to transform the amino groups of neomycin B in absence and presence of **apt1**. According to mass spectrometric analysis reaction of acetic acid NHS ester **3a** (10 equivalents) with the **apt1**-protected neomycin B resulted mainly in the

formation of *mono*-acetylated antibiotic derivatives (Fig. 2.2b). In stark contrast, the transformation of **1** under the same conditions but in absence of the APG yielded *di*-, *tri*-, *tetra*-, *penta* and *hexa*-acetylated aminoglycoside derivatives (Fig. 2.2c). These experiments clearly indicate the ability of **apt1** to inhibit the reactivity of multiple amine groups within neamine antibiotic **1**.

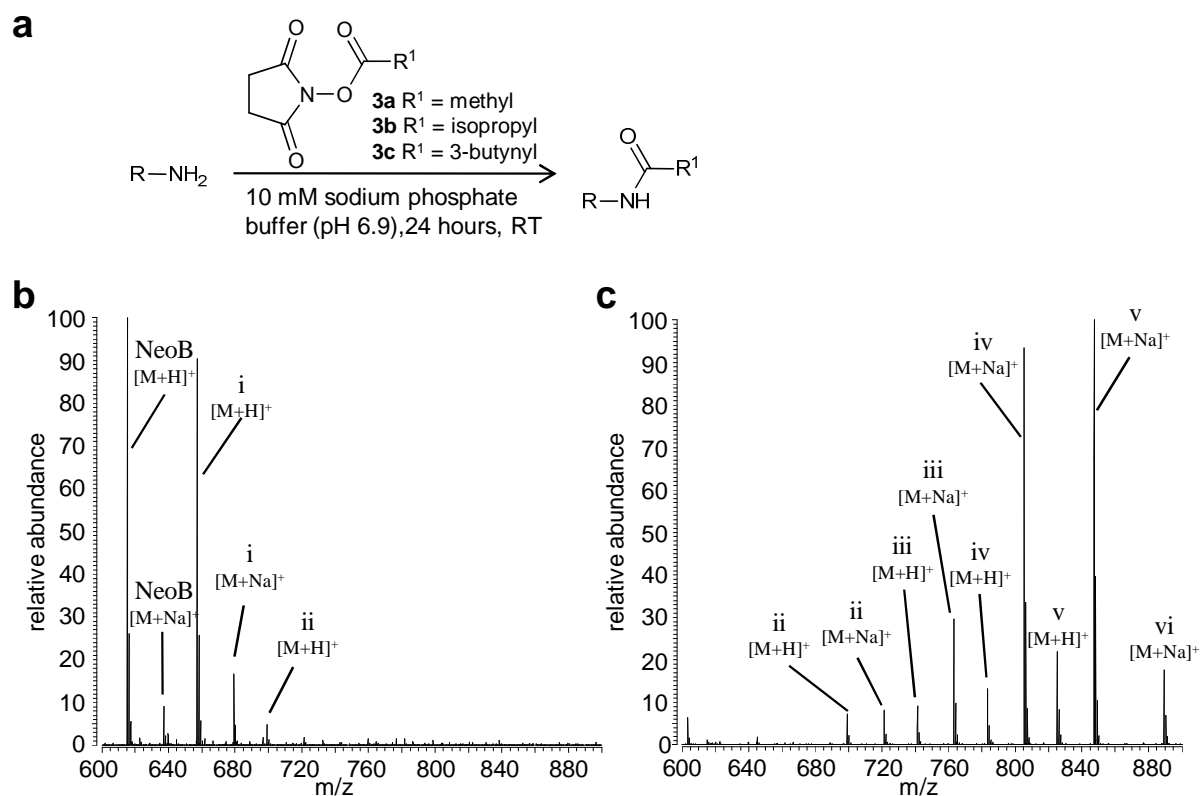

Figure 2.2: **a**, Reaction of amino groups ($R = \text{neomycin B}$) with NHS ester **3a-c** in sodium phosphate buffer at room temperature (RT). **b**, Electrospray Ionisation (ESI) Mass Spectra (MS) of reaction mixture of neomycin B (**1**, NeoB) with 10 equiv. activated ester **3a** in the presence of 1.5 equiv. **apt1**. **c**, ESI-MS spectra of reaction mixture of **1** with 10 equiv. NHS ester **3a** in absence of APG. (i-vi = number of reacted amino groups of **1**).

To obtain further insight into the regioselectivity of transformations of neomycin B, reaction conditions were optimized to yield *mono*-acetylated antibiotic for the protected (Fig. 2.3a) and non-protected transformations (Fig. 2.3b). RNA-neomycin B complex was reacted with 30 equivalents of the NHS ester **3a**, while the unprotected antibiotic **1** was incubated with only one equivalent. After purification by High Performance Liquid Chromatography (HPLC, see experimental part Fig. 2.12), the *mono*-acetylated neomycin B derivatives were characterized

and regioselectivities were calculated using $^1\text{H-NMR}$ spectroscopy (Fig. 2.3c). The RNA-protected aminoglycoside **1** was proven to be acetylated at the amino group in C6 position at ring IV with an extremely high regioselectivity of 95 % resulting in neomycin B derivative **4a**, while in absence of APG the amino groups in C6 position of ring II and ring IV were highly reactive. Thus, the unprotected neomycin B was mainly converted into two inseparable derivatives, 6'''-*N*-acetyl neomycin B **4a** and 6'-*N*-acetyl neomycin B **4b**, in a ratio of 9:11.

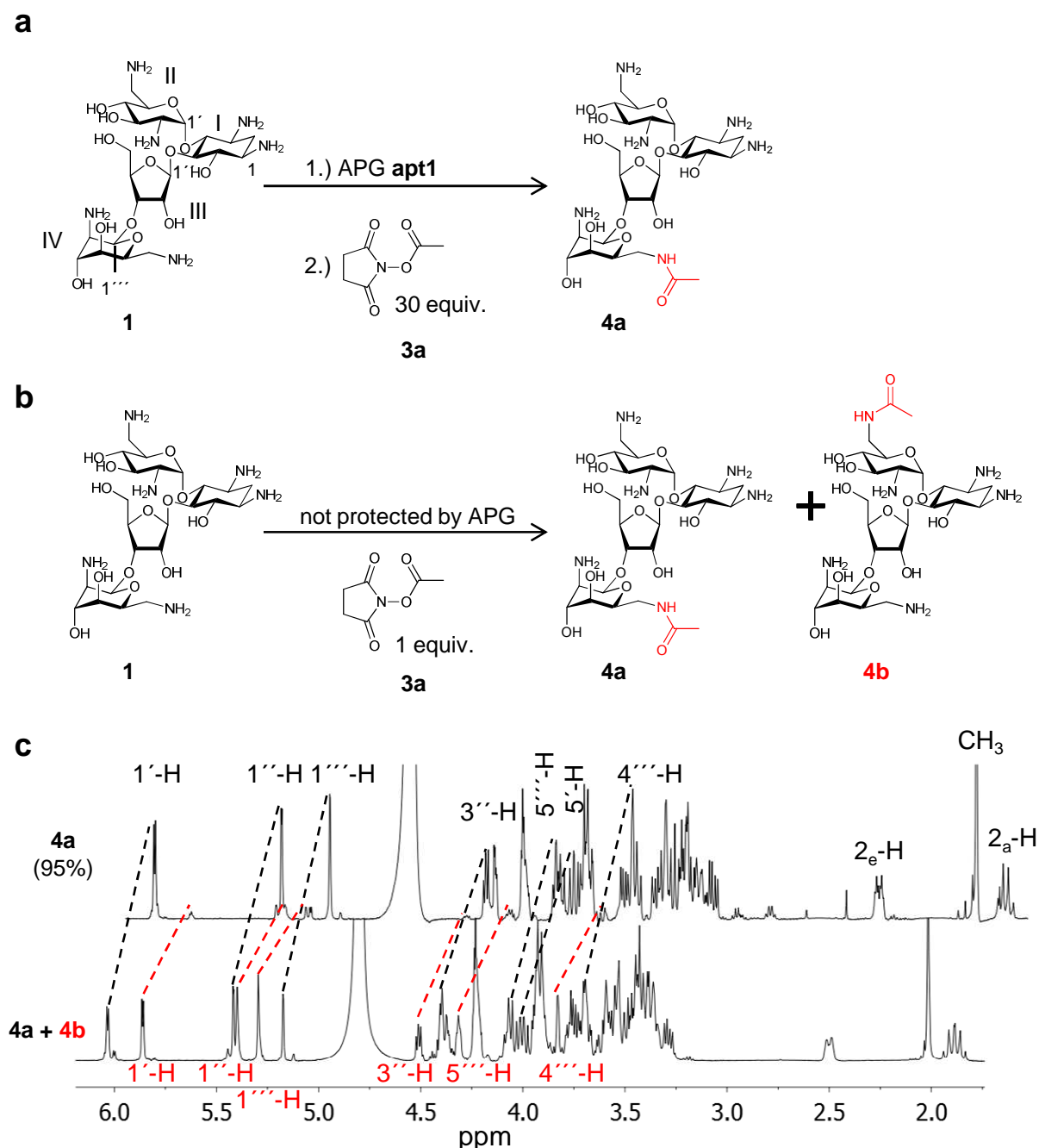

Figure 2.3: **a**, Regioselective acetylation of **1** in presence of 1.5 equiv. of **apt1** resulting in **4a**. **b**, Unselective transformation of **1** in absence of APG results in a mixture of **4a** and **4b**. **c**, $^1\text{H-NMR}$ (500 MHz, D_2O) spectra of regioselectively *mono*-acetylated neomycin B **4a** (upper) and mixture of regioisomers **4a** and **4b** (lower).

These results were confirmed by **H**eteronuclear **S**ingle **Q**uantum **C**oherence (HSQC) spectra (Fig. 2.4) and **A**ttached **P**roton **T**est (APT) measurements (see experimental part Fig. 2.11). As shown in Fig. 2.4a, spectrum of derivative **4a** shows a remarkable chemical shift of the $J(\text{C6}'''\text{-H})$ and $J(\text{C5}'''\text{-H})$ coupling of ring IV in comparison to the 2D-spectrum of neomycin B (Fig. 2.4b) proving the regioselective acetylation of amino group in C6 position of ring IV.

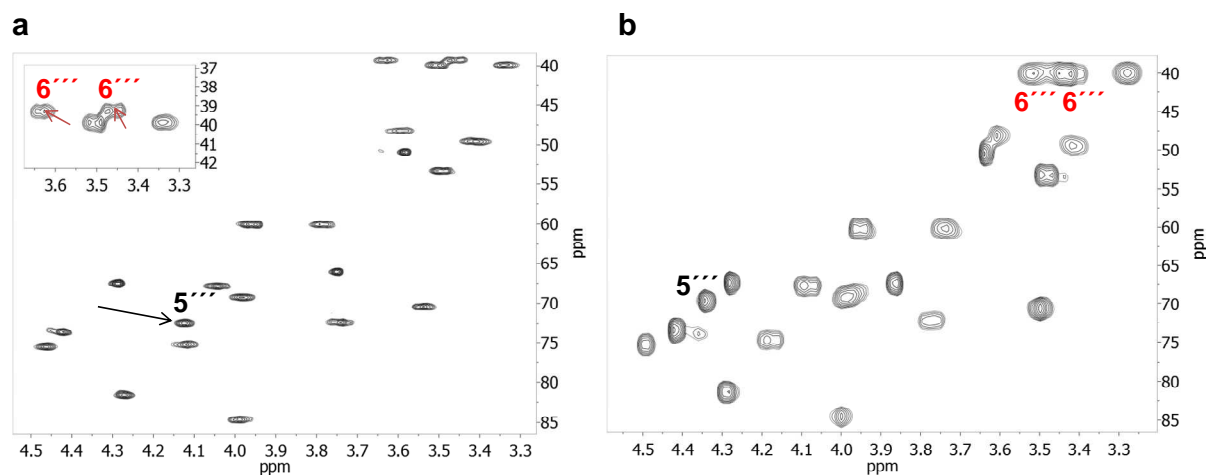

Figure 2.4 Sections of HSQC (500 MHz D_2O) spectra of *mono*-acetylated neomycin B **4a** (a) and neomycin B (b). Arrows indicate chemical shift of $J(\text{C6}'''\text{-H})$ (red) and $J(\text{C5}'''\text{-H})$ (black) coupling.

To test whether **apt1** can tolerate the introduction of larger residues than the acetyl group, neomycin B **1** was functionalized using the NHS esters **3b** and **3c** of isobutyric acid and 4-pentynoic acid, respectively. Again, remarkable regioselectivities of 97 % and 98 % were achieved for obtained derivatives **5** and **6**, respectively (Table 2.1). It is important to note here, that during the preparation of these derivatives, **apt1** even tolerated the addition of 6.7 volume % of the organic solvent dimethylformamide (DMF), which allowed easy solubilization of the hydrophobic activated esters **3b** and **3c**. In addition to these excellent regioselectivities, the APG-mediated modification exhibit conversions of neomycin B to antibiotic derivatives of up to 71 % (Table 2.1).

Table 2.1: Conversions and regioselectivities of acylation of neomycin B in presence of apt1.

Compound	APG	DMF vol%	R ₁	conv. [^] (%)	r.s. [*] (%)
4a **	apt1	0	methyl	48	95
5	apt1	6.7	isopropyl	64	97
6	apt1	6.7	3-butynyl	71	98

All reactions were carried out according to the general procedure in presence of 1.5 equiv. **apt1** (see experimental part 2.4.2.2). [^]Conversions of neomycin B to regioisomers **4a**, **5** and **6** were calculated from HPLC- and ¹H-NMR peak integrals assuming that only *mono*- and *di*-acylated derivatives were formed. ** Reaction was performed five times and the corresponding value of the regioselectivity and conversion is the calculated average. The error of the conversion was calculated to be 6 %. * Regioselectivities (r.s.) were calculated from ¹H-NMR spectra.

2.2.2 Regioselective Acylation of Neomycin B Employing Different APGs

Two even shorter RNA sequences (**apt2**: 5'-CUG CAG UCC GAA AAG GGC CAG-3', **apt3**: 5'-UGU AGG GCG AAA AGU UUU ACA-3') (Fig. 2.5) were also employed as APGs for antibiotic **1**, showing the concept is not limited to a single host-guest complex.

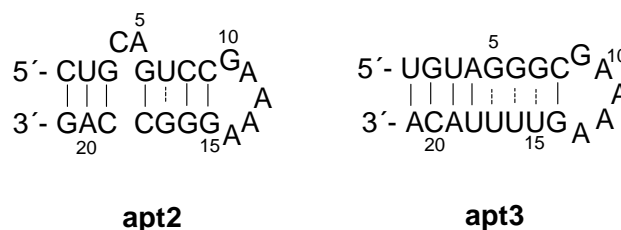
**Figure 2.5** Stem-loop structures of APGs **apt2** and **apt3**.⁹

These aptamers were chosen from a pool of 21 sequences generated in the same SELEX experiment as **apt1** performed by the group of *Famulok*.⁹ Again, high regioselectivities were obtained in the formation of acetyl neomycin B **4a**, reaching 94 % for **apt2** and 93 % for **apt3**, respectively (Table 2.2). The conversions of **1** were comparable with **apt1** (Table 2.2), reaching 49 % for **apt2** and 55 % using **apt3**, assuming that only *mono*- and *di*-acetylated neomycin B derivatives were formed. As shown in Table 2.2, the application of **apt2** as APG was also successful in the synthesis of **5** and **6** with high regioselectivities.

Table 2.2: Yield, conversions and regioselectivities of acylation of neomycin B in presence of different APGs.

Compound	APG	R ₂	conv. [^] (%)	yield ^{^^} (%)	r.s. [*] (%)
4a **	apt1	methyl	48	18 [†]	95
4a	apt1	methyl	48	45 ^{††}	94
4a **	apt2	methyl	49	29 [†]	94
4a	apt2	methyl	45	39 ^{††}	93
4a **	apt3	methyl	55	50 ^{††}	93
5	apt2	isopropyl	53	23 [†]	89
6	apt2	3-butynyl	63	19 [†]	96

All reactions were carried out according to the general procedure in presence of 1.5 equiv. APG (see experimental part 2.4.2.2). [^] Conversion (conv.) of **1** to antibiotic derivatives **4a**, **5** and **6** were calculated from HPLC- and ¹H-NMR peak integrals. ^{^^} Yields of *mono*-acylated derivatives (isomer mixture) were determined by HPLC. ^{*} Regioselectivity (r.s.) were calculated from ¹H-NMR spectra. ^{**} Reaction was performed three times and the corresponding values of the regioselectivities and conversions are the calculated averages. [†] Precipitation of RNA was employed as purification method. ^{††} Hydrolysis of RNA was employed as purification method.

In contrast to the moderate conversions, the isolation of the antibiotic derivatives out of the RNA complex was still challenging. So far, the antibiotic **1** and its derivatives were extracted from the complex by melting the RNA aptamer complex at high temperatures (99 °C) and a precipitation of the APG with the positively charged surfactant didodecyldimethylammonium bromide (diC₁₂DAB). While the resulting RNA surfactant complex was insoluble in the reaction buffer, the aminoglycoside **1** and its derivatives remained in solution. However, as shown in Table 2.2, antibiotic derivative **4a** was obtained with a yield of only 18 % and 29 % for **apt1** and **apt2**, respectively, applying this precipitation method. One reason for the low yield is most probably the co-precipitation of the aminoglycosides with the RNA. To improve the isolated yields of the aminoglycosides, the aptamer-complex was hydrolysed at 85 °C under basic conditions (pH = 14) instead. After destruction of the APGs, most amount of the neomycin B derivative **4a** was recovered reaching 45 %, 39 % and 50 % for **apt1**, **apt2** and **apt3**, respectively. (Table 2.2).

2.2.3 Regioselective Modification of a Related Antibiotic

Likewise, the APGs presented here can be used to modify other aminoglycosides with a similar pharmacophore. For instance, the related antibiotic paromomycin **2** could be transformed to the corresponding *N*-acetyl derivative **7** employing **apt1** as APG (Fig. 2.6a). Antibiotic derivative, 6'''-*N*-acetyl paromomycin **7**, was obtained with a yield of 22 % employing the precipitation of the RNA as purification method. Furthermore, the acetylation of paromomycin reached excellent regioselectivity of >90 %. As shown in Figure 2.6c, spectrum of derivative **7** shows a remarkable chemical shift of the $J(\text{C6}'''\text{-H})$ and $J(\text{C5}'''\text{-H})$ coupling in comparison to the 2D-spectrum of paromomycin **2** (Fig. 2.6b) proving the regioselective acetylation of amino group in C6 position of ring IV. This result demonstrates successfully that for the protection of the related antibiotics neomycin B **1** and paromomycin **2** the interaction of the neamine moiety (ring I and II) is essential. Therefore, it can be concluded that the identified RNA aptamers against a particular structure can be applied as APGs for related molecules exhibiting a similar molecular shape. Furthermore, in light of many antibiotic derivatives presented in this studies, it should be apparent that the APG paradigm decreases the number of synthetic steps necessary for the modification of complex molecules to the extreme and is superior to previously reported non-covalent protective group approaches.^{24,25,26} Ring-IV-altered neomycin B derivatives have been previously described and were only obtained after extensive synthesis including more than 20 synthetic steps (see experimental part Scheme 2.2-2.6)^{3,29}. Our newly developed technology allows the production of such antibiotic derivatives modified at the same positions in a single reaction.

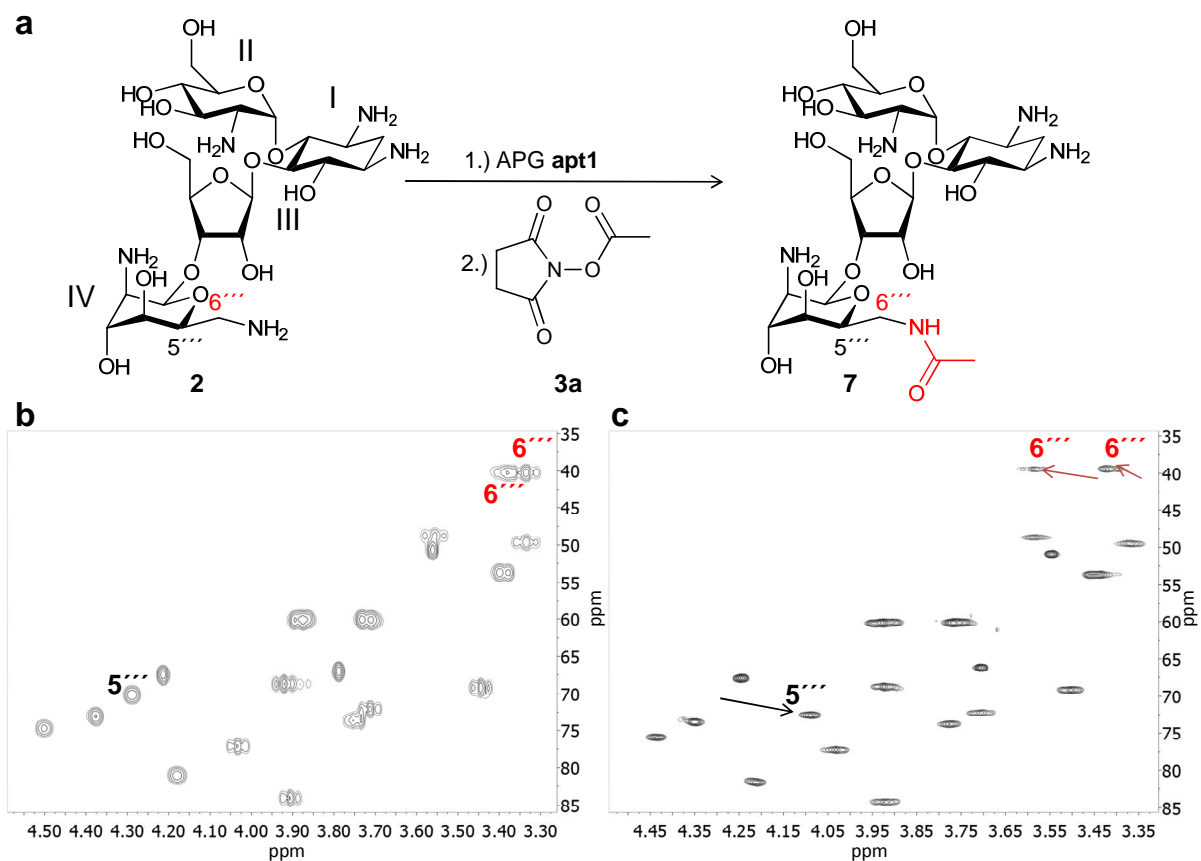

Figure 2.6 a, Regioselective acetylation of paromomycin **2** using 30 equiv. of activated ester **3a** in presence of 1.5 equiv. **apt1**. **b**, Sections of HSQC-spectra of antibiotic **2**. **c**, Sections of HSQC (500MHz, D_2O) spectra of *mono*-acetylated antibiotic derivative **7**. Arrows indicate chemical shift of $J(\text{C6}'''\text{-H})$ (red) and $J(\text{C5}'''\text{-H})$ (black) coupling.

2.3 Conclusion

In this chapter, we have demonstrated the effective use of RNA sequences as non-covalent aptameric protective groups for the highly chemo- and regioselective derivatization of complex molecules bearing several functional groups with similar reactivity. This was successfully demonstrated for the structural complex aminoglycoside antibiotics neomycin B and paromomycin with three different aptamer sequences. These natural antibiotics were modified in a single step with substituents of variable size and hydrophobicities employing acylation that proceeds with excellent regioselectivities (89 % to 98 %) and good conversions of up to 71 %. However, at this point it has to be stressed that prior to the facile derivatization the generation of RNA aptamers by a SELEX experiment is necessary to obtain APGs. However, according to these results APGs merit consideration as a new synthetic strategy in organic synthesis as they can be evolved for a large variety of target molecules bearing

different structural features and their generation relies on a well-established *in vitro* evolution process. Moreover, APGs based on RNA aptamers can become an effective tool for the derivatization of complex natural products and vastly simplify drug development.

2.4 Experimental Section

2.4.1 Materials & Methods

¹H-NMR-, ¹³C-NMR-, heteronuclear single-quantum correlation (HSQC) spectra and attached proton test (APT) were recorded on a Varian Unity Inova (500 MHz for ¹H-NMR and HSQC, 125 MHz for APT and ¹³C-NMR) and Oxford AS400 (400 MHz for ¹H-NMR and 100.6 MHz for APT and ¹³C-NMR) NMR spectrometer at 25 °C using 3 mm NMR tubes (*Sigma Aldrich*). High resolution mass spectrometry (HRMS) was carried out on a LTQ ORBITRAP XL instrument (*Thermo Scientific*) employing electron impact ionization in positive ion mode (EI+). Chromatographic separations were carried out on a *Shimadzu* VP series HPLC modular system (DGU-14A3 Online Vacuum-Degasser, two LC-20 AT pumps, SIL-20A auto sampler, CTP-20 A column oven, RID-10 refractive detector, FRC-10 A fraction collector and *Shimadzu* LCsolution software). HPLC purification was performed with a Waters Spherisorb ODS-2 C₁₈ analytical column (250 x 4.6 mm, spherical particles of 5 μm and 80 Å pore size) using isocratic elution at 40 °C. A pH-meter (*Hanna Instruments* pH 209) equipped with a glass combination electrode was used for pH adjustments of the reaction buffers. All chemicals and reagents were purchased from commercial suppliers and used without further purification, unless otherwise noted. Neomycin B trisulfate x hydrate (VETRANAL[®]), paromomycin sulfate salt (98 %), *N,N*-dimethylformamide (DMF, 99 %), *N*-hydroxysuccinimide (NHS, 98 %), trifluoroacetic anhydride (99 %), dichloromethane (DCM, 99.5 %), tetrahydrofuran (THF, 99.9 %), pyridine (99 %), 4-pentynoic acid (95 %), acetic acid (99 %), isobutyric acid (99 %) and toluene (99.8 %) were purchased from *Sigma Aldrich* and used as received. For HPLC purification heptafluorobutyric acid (HFBA) (*Fluka*, puriss. p.a., for ion chromatography) and acetone (*Sigma-Aldrich*, HPLC grade) were used. Ultrapure water (specific resistance > 18.4 MΩ cm) was obtained by Milli-Q water purification system (*Sartorius*[®]). RNA aptamers (82 – 91 % purity) were purchased from *BioSpring* (Frankfurt am Main, Germany) and *riboxx* GmbH (Radebeul, Germany). Acetic acid *N*-hydroxysuccinimide esters **3a** was synthesized according to a literature procedure.²⁷ For the

regioselective transformation Milli-Q water was treated with diethylpyrocarbonate (DEPC) and sterilized using an autoclave (121 °C, 20 min).

2.4.2 General Procedures

2.4.2.1 Synthesis of Activated Ester for Antibiotic Modification²⁸

To 56.4 mL trifluoroacetic acid anhydride (0.47 mol) were added 20 g of *N*-hydroxysuccinimide (0.196 mol) at 0 °C. The reaction was allowed to warm up to room temperature over 24 hours. Then 50 mL toluene were added and the volatile was removed in vacuo. The residue was taken up in 15 mL dichloromethane and the remaining solvent was removed in vacuo. The resulting product, *N*-trifluoroacetoxysuccinimide, was used without any further purification for the next step. To a solution of a carboxylic acid (17.5 mmol) in 15 mL THF were added 5 g *N*-trifluoroacetoxysuccinimide (23.7 mmol) and 2.1 mL pyridine (26.4 mmol) at 0 °C. The reaction mixture was allowed to warm up to room temperature over 24 h, before being quenched with 20 mL water. The aqueous phase was extracted twice with 75 mL of a 1:1 mixture of diethyl ether and hexane. The combined organic phases were washed with 100 mL sat. aq. NH₄Cl solution, 100 mL sat. aq. NaHCO₃ solution and 100 mL brine, dried over MgSO₄, filtered and concentrated to yield activated ester **3b** and **3c**.

2.4.2.2 Regioselective Acylation of Aminoglycoside Antibiotics

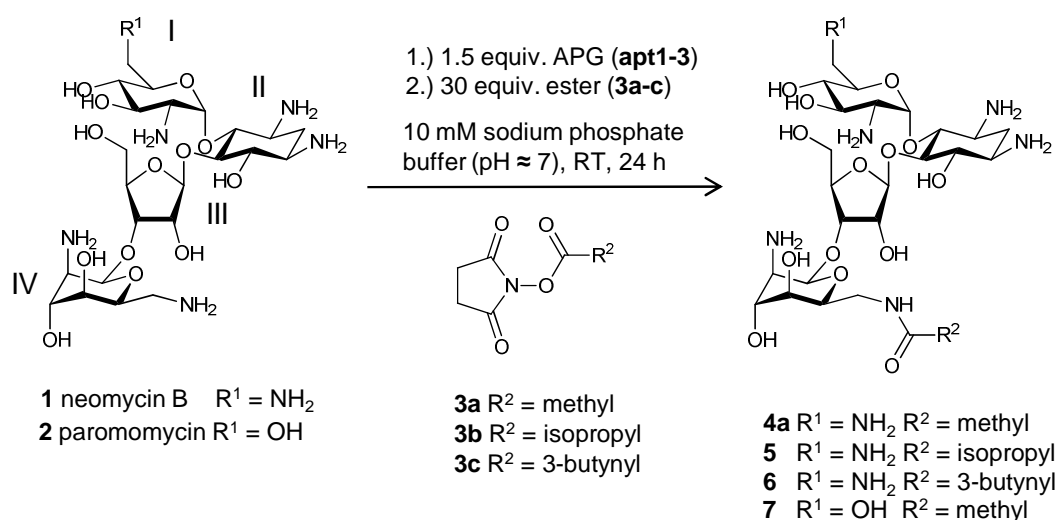

Scheme 2.1: Regioselective transformation of amino group in C6 position of ring IV.

A volume of 272 μL of a 6.1 mM RNA aptamer solution (sequences: 5'-GGA CUG GGC GAG AAG UUU AGU CC-3' (**apt1**), 5'-CUG CAG UCC GAA AAG GGC CAG-3' (**apt2**))

or 5'-UGU AGG GCG AAA AGU UUU ACA-3' (**apt3**) (1.66 μmol) in 10 mM sodium phosphate buffer (pH 6.8) was heated to 85 °C for 10 min and was afterwards kept at room temperature for 15 min. Then 228 μL of a 4.8 mM solution of the aminoglycoside antibiotic (1.09 μmol) in 10 mM sodium phosphate buffer (pH 7.4) were added and the mixture was allowed to stand for 30 min at room temperature. Afterwards, 30 equiv. NHS ester (32.8 μmol) dissolved in 500 μl sodium phosphate buffer (pH 7.4) (for activated ester **3a**) or in 36 μl DMF (for activated esters **3b** and **3c**) were added and the reaction mixture was allowed to react for 24 hours at room temperature. After addition of 60 μL of a 7 wt. % ethylamine water solution, the mixture was incubated for 30 min at room temperature and afterwards purified by following possible methods:

- a) Precipitation of RNA: The reaction mixture was heated to 99 °C for 10 min and to the hot solution 1 mL of a 53 mM aqueous solution of diC₁₂DAB were added to precipitate the RNA. After incubation for 15 min at room temperature and centrifugation for 30 min at 6 °C (14k rpm) the supernatant was freeze-dried. To obtain sufficient amounts of antibiotic derivatives for 2D-NMR spectroscopy the synthetic step and the purification was performed three times. Thus, the resulting freeze dried samples from three runs were dissolved together in 400 μL water. Each 30 μL fraction of this solution was purified by HPLC using a Waters Spherisorb ODS-2C₁₈ analytic column (water/acetone 1:0.9 containing 12.1 mM HFBA) at a flow rate of 1 ml/min at 40 °C to afford the antibiotic derivatives **4a**, **5** and **6**. After evaporation of acetone and freeze-drying the product was dissolved in 150 μL D₂O for NMR studies.
- b) Hydrolysis of RNA: To the reaction mixture a volume of 160 μL of a aq. 2 M NaOH solution was added and allowed to incubate at 85 °C for 30 min. After cooling to room temperature each 50 μL fraction of this solution was purified by HPLC as described in method a) using water/acetone 1:0.81 containing 16.9 mM HFBA as eluent to obtain antibiotic derivative **4a**.

2.4.3 Characterization of Activated Esters & Synthesized Antibiotic Derivatives

2,5-dioxopyrrolidin-1-yl isobutyrate (3b). The title compound was prepared according to

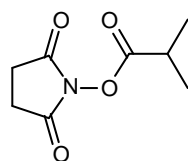

the general procedure described above. Product **3b** was obtained as a white solid reaching a yield of 72 % (2.33 g, 12.6 mmol). $^1\text{H-NMR}$ (CDCl_3 , 400 MHz): δ [ppm] = 2.79 (septet, $J = 7.0$ Hz, 1H, $\text{CH}(\text{CH}_3)_2$); 2.72 (s, 4H, $\text{CH}_2\text{-CO}$); 1.22 (d, $J = 7.6$ Hz, 6H, $\text{CH}(\text{CH}_3)_2$). $^{13}\text{C-NMR}$ (CDCl_3 , 100.6 MHz): δ (p.p.m.) = 172.06 (1C, CO-CH); 169.38 (2C, CO-CH_2); 31.57 (1C, $\text{CH}(\text{CH}_3)_2$); 25.50 (2C, CO-CH_2); 18.63 (2C, $\text{CH}(\text{CH}_3)_2$).

2,5-dioxopyrrolidin-1-yl pent-4-ynoate (3c). The title compound was prepared according to

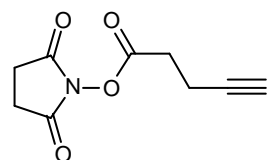

the general procedure described above. Product **3c** was obtained as a white solid reaching a yield of 50 % (1.69 g, 8.7 mmol). $^1\text{H-NMR}$ (CDCl_3 , 500 MHz): δ (p.p.m.) = 2.86 (t, $J = 7.5$ Hz, 2H, $\text{CH}_2\text{-CH}_2\text{-C}\equiv\text{CH}$); 2.82 (s, 4H, CH_2); 2.59 (t, $J = 7.5$ Hz, 2H, $\text{CH}_2\text{-CH}_2\text{-C}\equiv\text{CH}$); 2.04 (s, 1H, $\text{C}\equiv\text{CH}$). $^{13}\text{C-NMR}$ (CDCl_3 , 100.6 MHz): δ [ppm] = 169.05 (2C, CO); 167.12 (1C, CO); 80.98 (1C, $\text{C}\equiv\text{CH}$); 70.13 (1C, $\text{C}\equiv\text{CH}$); 30.37 (1C, $\text{CH}_2\text{-CH}_2\text{-C}\equiv\text{CH}$); 25.66 (2C, CH_2), 14.16 (1C, $\text{CH}_2\text{-CH}_2\text{-C}\equiv\text{CH}$).

6''''-N-acetyl neomycin B x 5 HFBA (4a). The title compound was prepared according to the

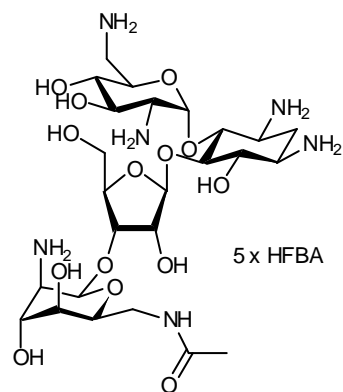

general procedure described above using NHS ester **3a**. Derivative **4a** was obtained as a white solid. For the measurement of regioselectivity and the characterization of the compound $^1\text{H-NMR}$, HSQC as well as APT spectra were recorded and electrospray ionization (ESI)-MS was employed. The yield was calculated from $^1\text{H-NMR}$ - and HPLC peak integrals: $R_t = 7.6$ min, 45 % yield (apt1). TLC ($\text{CHCl}_3/\text{MeOH}/17\% \text{NH}_4\text{OH}$ 2:1:1 v/v/v) $R_f = 0.52$. $^1\text{H-NMR}$ (D_2O , 500 MHz) δ (p.p.m.) 6.06 (d, $J = 4$ Hz, 1H, 1- H'), 5.44 (d, $J = 2$ Hz, 1H, 1- H''), 5.20 (d, $J = 1.5$ Hz, 1H, 1- H'''), 4.44 (t, $J = 5.75$ Hz, 1H, 3- H''), 4.39 (dd, $J = 5$ Hz, $J = 2$ Hz, 1H, 2- H''), 4.26 (t, $J = 3$ Hz, 1H, 3- H'''), 4.24 (m, 1H, 4- H''), 4.09 (t, $J = 6.75$ Hz, 1H, 5- H'''), 4.07 (m, 1H, 4-H), 4.01 (t, $J = 10$ Hz, 1H, 5- H'), 3.98 – 3.92 (m, 3H, 5- H_a'' , 5-H, 3- H'), 3.76 (dd, 1H, $J = 12.5$ Hz, $J = 5.5$ Hz, 5- H_b''), 3.72- 3.68 (m, 2H, 4- H''' , 6-H), 3.60 (dd, $J = 14$ Hz, $J = 7.5$ Hz, 1H, 6- H_a'''), 3.56 (m, 2H, 3-H, 2- H'''), 3.53-3.41 (m, 4H, 6- H_a' , 2- H' , 6- H_b''' , 4- H'), 3.38 (m, 1H, 1-H), 3.32

(dd, $J = 14$ Hz, $J = 6$ Hz, 1H, 6- H_b '), 2.51 (dt, $J = 12.5$ Hz; $J = 3.8$ Hz, 1H, 2- H_{eq}), 2.04 (s, 3H, CH_3), 1.89 (dd, $J = 12.7$ Hz, 1H, 2- H_{ax}). APT (D_2O , 125.7 MHz) δ (p.p.m.) 174.49 (Carbonyl-C), 110.00 (C-1''), 95.51 (C-1'''), 95.49 (C-1'), 84.62 (C-5), 81.66 (C-4'), 75.39 (C-3'), 75.29 (C-4), 73.58 (C-2'), 72.45 (C-5'''), 72.42 (C-6), 70.35 (C-4'), 69.22 (C-3'), 67.88 (C-5'), 67.56 (C-3'''), 66.10 (C-4'''), 60.00 (C-5'), 53.15 (C-2'), 50.90 (C-2'''), 49.65 (C-1), 48.16 (C-3), 39.85 (C-6'), 39.33 (C-6'''), 27.88 (C-2), 21.74 (CH_3). MS (EI+) (m/z): found 657.33008 $[M+H]^+$, 679.31226 $[M+Na]^+$; calculated 657.33013 $[M+H]^+$, 679.31207 $[M+Na]^+$.

6'''-N-2-methylpropanoyl neomycin B x 5 HFBA (5). The title compound was prepared

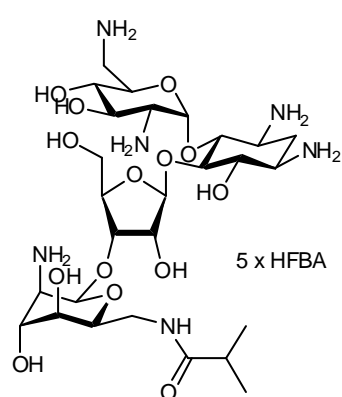

according to the general procedure described above using NHS ester **3b**. Derivative **5** was obtained as a white solid. For the measurement of regioselectivity and the characterization of the compound 1H -NMR and HSQC spectra were recorded and ESI-MS was employed. The yield was calculated from 1H -NMR- and HPLC peak integrals: $R_t = 9.65$ min, 30 % yield (apt1). TLC ($CHCl_3/MeOH/17$ % NH_4OH 2:1:1 v/v/v) $R_f = 0.50$. 1H -NMR (D_2O , 500 MHz) δ (p.p.m.) 5.98 (s, 1H, 1- H'), 5.38 (s, 1H, 1- H''), 5.15 (s, 1H, 1- H'''), 4.39 (d, $J = 6.0$ Hz, 1H, 3- H''), 4.37 (m, 1H, 2- H''), 4.21 (m, 1H, 3- H'''), 4.17 (m, 1H, 4- H''), 4.06-4.01 (m, 2H, 5- H''' , 4-H), 3.96 (t, $J = 10.3$ Hz, 1H, 5- H'), 3.92 – 3.88 (m, 3H, 5- H_a'' , 5-H, 3- H'), 3.70 (dd, 1H, $J = 14$ Hz, $J = 5.8$ Hz, 5- H_b''), 3.65-3.61 (m, 2H, 4- H''' , 6-H), 3.54-3.50 (m, 3H, 6- H_a''' , 3-H, 2- H''), 3.46 (m, 1H, 4- H'), 3.44-3.38 (m, 3H, 6- H_a' , 2- H' , 6- H_b''), 3.36-3.33 (m, 1H, 1-H), 3.28 (dd, $J = 13.5$ Hz, $J = 6$ Hz, 1H, 6- H_b'), 2.47 (m, 2H, $CH(CH_3)_2$, 2- H_{eq}), 1.86 (dd, $J = 12.2$ Hz, 1H, 2- H_{ax}), 1.09 (s, $J = 6.5$ Hz, 6H, CH_3).

^{13}C -signals based on HSQC (D_2O , 500 MHz) δ (p.p.m.) 110.3 (C-1''), 95.5 (C-1'), 95.2 (C-1'''), 84.7 (C-5), 81.5 (C-4'), 75.2 (C-4), 74.9 (C-3'), 73.5 (C-2'), 72.5 (C-5'''), 72.4 (C-6), 70.4 (C-4'), 69.2 (C-3'), 67.9 (C-5'), 67.5 (C-3'''), 66.1 (C-4'''), 60.0 (C-5'), 53.3 (C-2'), 50.9 (C-2'''), 49.6 (C-1), 48.2 (C-3), 39.9 (C-6'), 39.0 (C-6'''), 34.9 ($CH(CH_3)_2$), 28.0 (2C, $CH(CH_3)_2$), 27.9 (C-2); signal of quaternary carbon (CO) is missing due to the fact that it is not detectable by HSQC spectroscopy. MS (EI+) (m/z): found 685.36163 $[M+H]^+$, 707.34369 $[M+Na]^+$; calculated 685.36143 $[M+H]^+$, 707.34337 $[M+Na]^+$.

6'''-N-4-pentynoyl neomycin B x 5 HFBA (6). The title compound was prepared according

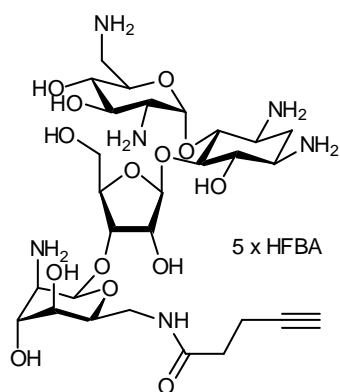

to the general procedure described above using NHS ester **3c**. Derivative **6** was obtained as a white solid. For the measurement of regioselectivity and the characterization of the compound $^1\text{H-NMR}$ and HSQC spectra were recorded and ESI-MS was employed. The yield was calculated from $^1\text{H-NMR}$ - and HPLC peak integrals: $R_t = 9.8$ min, 41 % yield (apt1). TLC ($\text{CHCl}_3/\text{MeOH}/17\% \text{NH}_4\text{OH}$ 2:1:1 v/v/v) $R_f = 0.60$. $^1\text{H-NMR}$ (D_2O , 500 MHz) δ (p.p.m.) 6.06 (d, $J = 4$ Hz, 1H, 1-H'), 5.43 (s, 1H, 1-H''), 5.19 (s, 1H, 1-H'''), 4.47 (d, $J = 5.75$ Hz, 1H, 3-H'), 4.41 (m, 1H, 2-H'), 4.26 (m, 1H, 3-H''), 4.22 (m, 1H, 4-H'), 4.11 - 4.06 (m, 2H, 5-H''', 4-H), 4.01 (t, $J = 10$ Hz, 1H, 5-H'), 3.97 - 3.94 (m, 3H, 5-H_a'', 5-H, 3-H'), 3.77 (dd, $J = 13$ Hz, $J = 5$ Hz, 1H, 5-H_b''), 3.75- 3.68 (m, 2H, 4-H''', 6-H), 3.61 (dd, $J = 14$ Hz, $J = 7.5$ Hz, 1H, 6-H_a''), 3.56-3.53 (m, 2H, 3-H, 2-H'''), 3.52 - 3.45 (m, 4H, 4-H', 6-H_a', 2-H', 6-H_b''), 3.36 (m, 1H, 1-H), 3.33 (dd, $J = 14$ Hz, $J = 6$ Hz, 1H, 6-H_b'), 2.56 - 2.43 (m, 6H, $(\text{CH}_2)_2$, 2-H_{eq}, $\text{C}\equiv\text{C-H}$), 1.90 (dd, $J = 12.3$ Hz, 1H, 2-H_{ax}).

^{13}C -signals based on HSQC (D_2O , 500 MHz) δ (p.p.m.) 110.1 (C-1'), 95.5 (C-1'), 95.3 (C-1'''), 84.7 (C-5), 81.6 (C-4'), 75.2 (C-3'), 75.1 (C-4), 73.5 (C-2'), 72.7 (C-5'''), 72.4 (C-6), 70.5 (C-4'), 70.4 ($\text{C}\equiv\text{CH}$), 69.2 (C-3'), 67.9 (C-5'), 67.5 (C-3'''), 66.1 (C-4'''), 60.1 (C-5'), 53.3 (C-2'), 50.9 (C-2'''), 49.5 (C-1), 48.2 (C-3), 39.9 (C-6'), 39.3 (C-6'''), 34.2 ($\text{CO-CH}_2\text{-CH}_2$), 27.8 (C-2), 14.5 ($\text{CO-CH}_2\text{-CH}_2$); signals of quaternary carbons (CO, $\text{C}\equiv\text{CH}$) is missing due to the fact that they are not detectable by HSQC spectroscopy. MS (EI+) (m/z): found 695.34564 $[\text{M}+\text{H}]^+$, 717.32770 $[\text{M}+\text{Na}]^+$; calculated 695.34578 $[\text{M}+\text{H}]^+$, 717.32772 $[\text{M}+\text{Na}]^+$.

6'''-N-acetyl paromomycin x 4 HFBA (7). The title compound was prepared according to

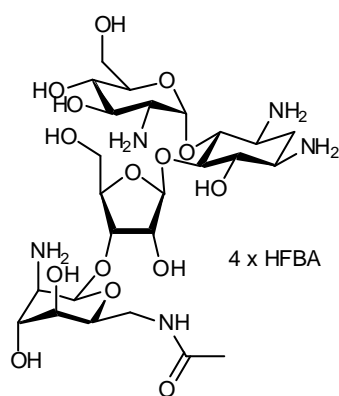

the general procedure describe above using NHS ester **3a**. Derivative **7** was obtained as white solid. For the measurement of regioselectivity and the characterization of the compound $^1\text{H-NMR}$, HSQC as well as APT spectra were recorded and ESI-MS was employed. The yield was calculated from $^1\text{H-NMR}$ - and HPLC peak integrals: $R_t = 4.78$ min, 22 % yield (apt1). $^1\text{H-NMR}$ (D_2O , 500MHz): δ (p.p.m.) = 5.81 (d, $J = 3.5\text{Hz}$, 1H, 1-H'); 5.39 (s, 1H, 1-H''); 5.20 (s, 1H, 1-H'''); 4.44 (t, $J = 5.5\text{Hz}$, 1H, 3-H'); 4.36 (m, 1H, 2-H'); 4.25 (m, 1H, 3-H''); 4.22 (m, 1H, 4-H'), 4.10 (t, $J = 6.5$ Hz, 1H,

Aptameric Protective Groups for One-Step Modification of Aminoglycoside Antibiotics

5-H^{''}); 4.04 (t, J = 7.8 Hz, 1H, 4-H); 3.97 – 3.89 (m, 4H, 6-H_a['], 5-H_a^{''}, 3-H['], 5-H); 3.81-3.75 (m, 3H, 6-H_b['], 5-H_b^{''}, 5-H[']); 3.73 - 3.67 (m, 2H, 4-H^{''}, 6-H); 3.62 – 3.57 (m, 2H, 6-H_a^{''}, 3-H); 3.55 (m, 1H, 2-H^{''}); 3.51 (t, J = 9.3 Hz, 1H, 4-H[']); 3.43 (m, 1H, 2-H[']); 3.42 (dd, J = 15 Hz, J = 6 Hz, 1H, 6-H_b^{''}); 3.38 - 3.35 (m, 1H, 1-H); 2.51 (dt, J = 12.5 Hz, J = 2.5 Hz, 1H, 2-H_{eq}); 2.04 (s, 3H, CH₃); 1.86 (dd, J = 12.5 Hz, 1H, 2-H_{ax}). APT (D₂O, 125.7 MHz): δ (p.p.m.) = 174.93 (CO); 109.78 (C-1[']); 95.98 (C-1[']); 95.56 (C-1^{''}); 84.11 (C-5); 81.53 (C-4[']); 77.23 (C-4); 75.53 (C-3[']); 73.73 (C-5[']); 73.44 (C-2[']); 72.51 (C-5^{''}); 72.16 (C-6); 69.08 (C-4[']); 68.63 (C-3[']); 67.56 (C-3^{''}); 66.13 (C-4^{''}); 60.11 (C-6['], C-5[']); 53.161 (C-2[']); 50.88 (C-2^{''}); 49.48 (C-1); 48.63 (C-3); 39.38 (C-6^{''}); 27.87 (C-2); 21.71 (CH₃). found 658.31311 [M+H]⁺, 680.29468 [M+Na]⁺; calculated 658.31414 [M+H]⁺, 680.29609 [M+Na]⁺.

2.4.4 NMR-Spectra of Antibiotics & Synthesized Antibiotic Derivatives

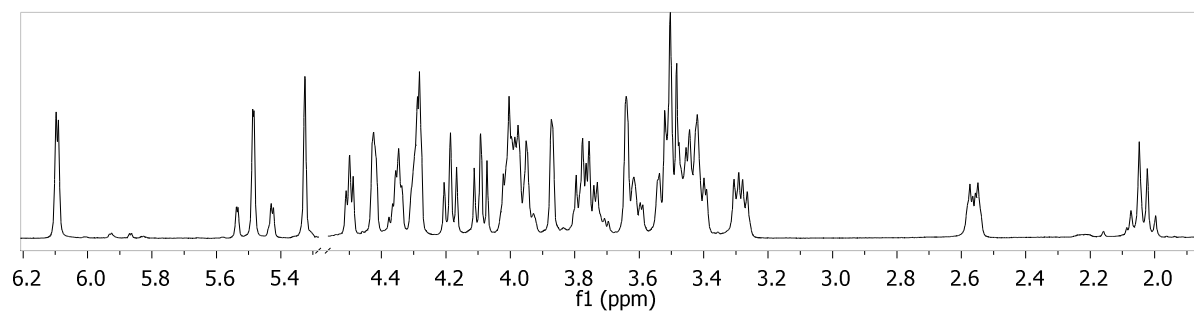

Figure 2.7a: ^1H -NMR (500 MHz, D_2O) spectrum of neomycin B x 6 HFBA **1**.

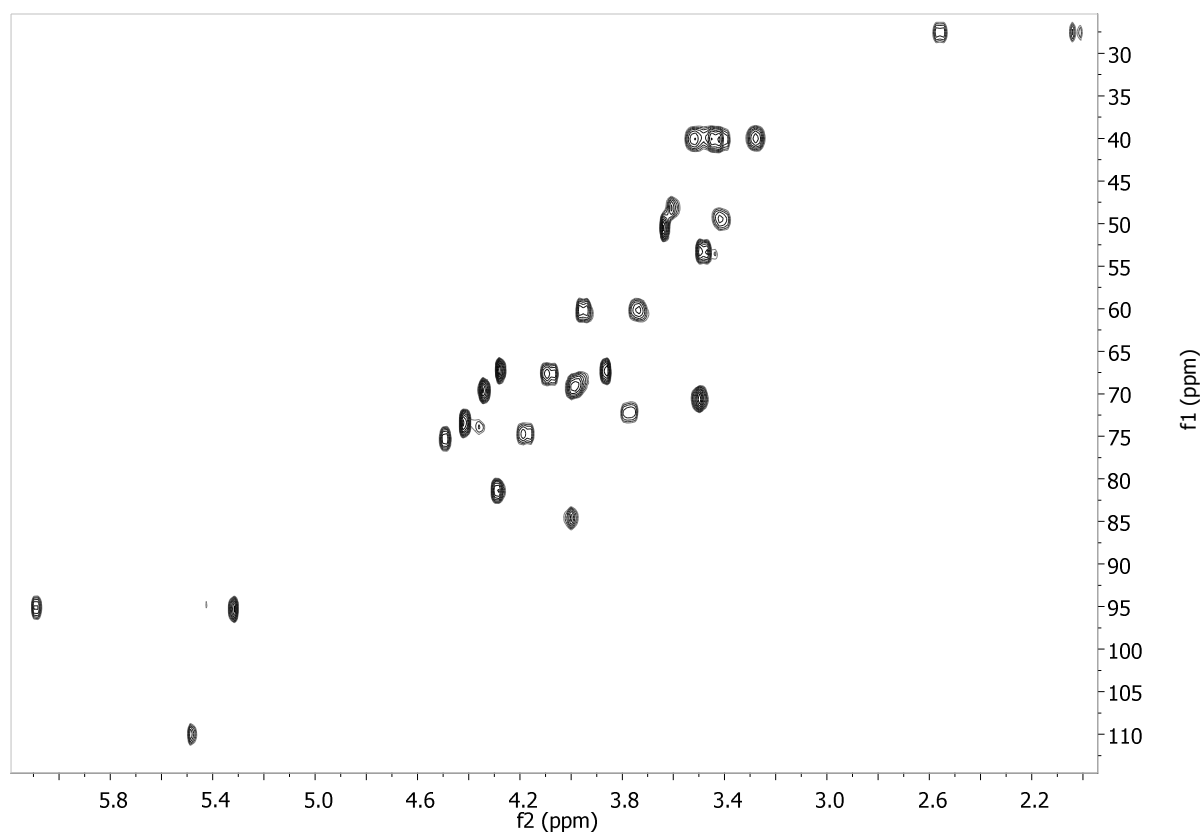

Figure 2.7b: HSQC (500 MHz, D_2O) spectrum of neomycin B x 6 HFBA **1**.

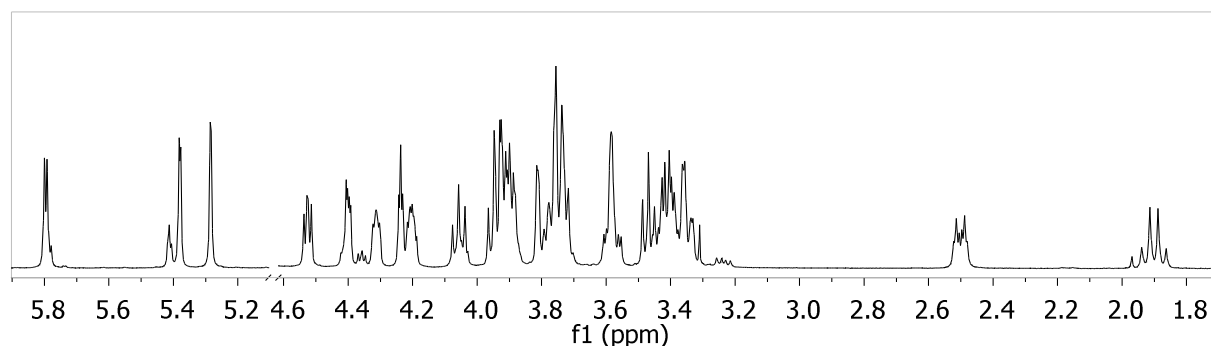

Figure 2.8a: $^1\text{H-NMR}$ (500 MHz, D_2O) spectrum of paromomycin x 5 HFBA **2**.

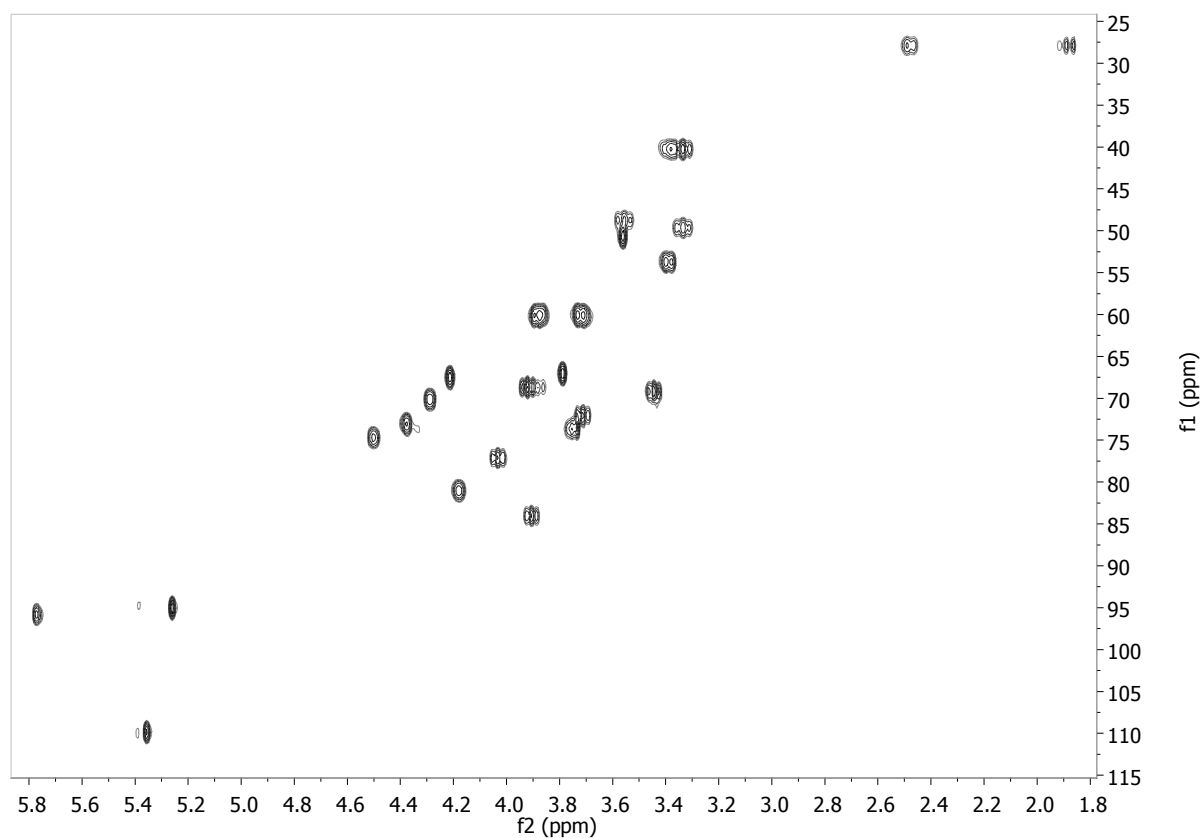

Figure 2.8b: HSQC (500 MHz, D_2O) spectrum of paromomycin x 5 HFBA **2**.

Chapter 2

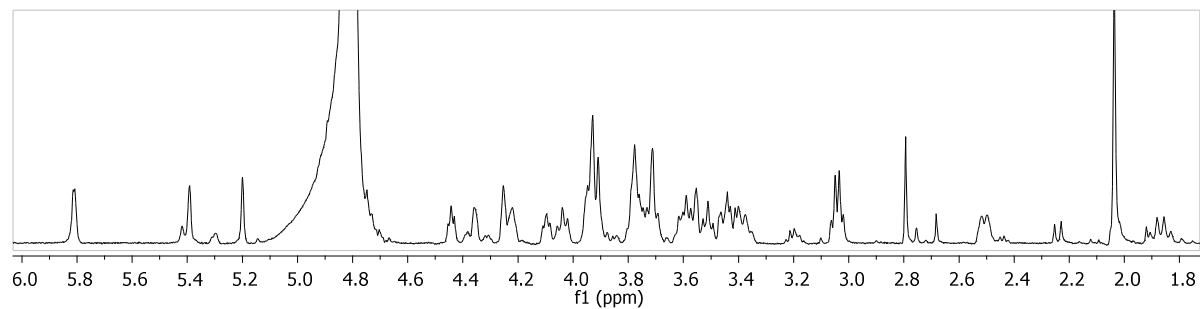

Figure 2.9a: $^1\text{H-NMR}$ (500 MHz, D_2O) spectrum of 6'''-*N*-acetyl paromomycin x 4 HFBA 7.

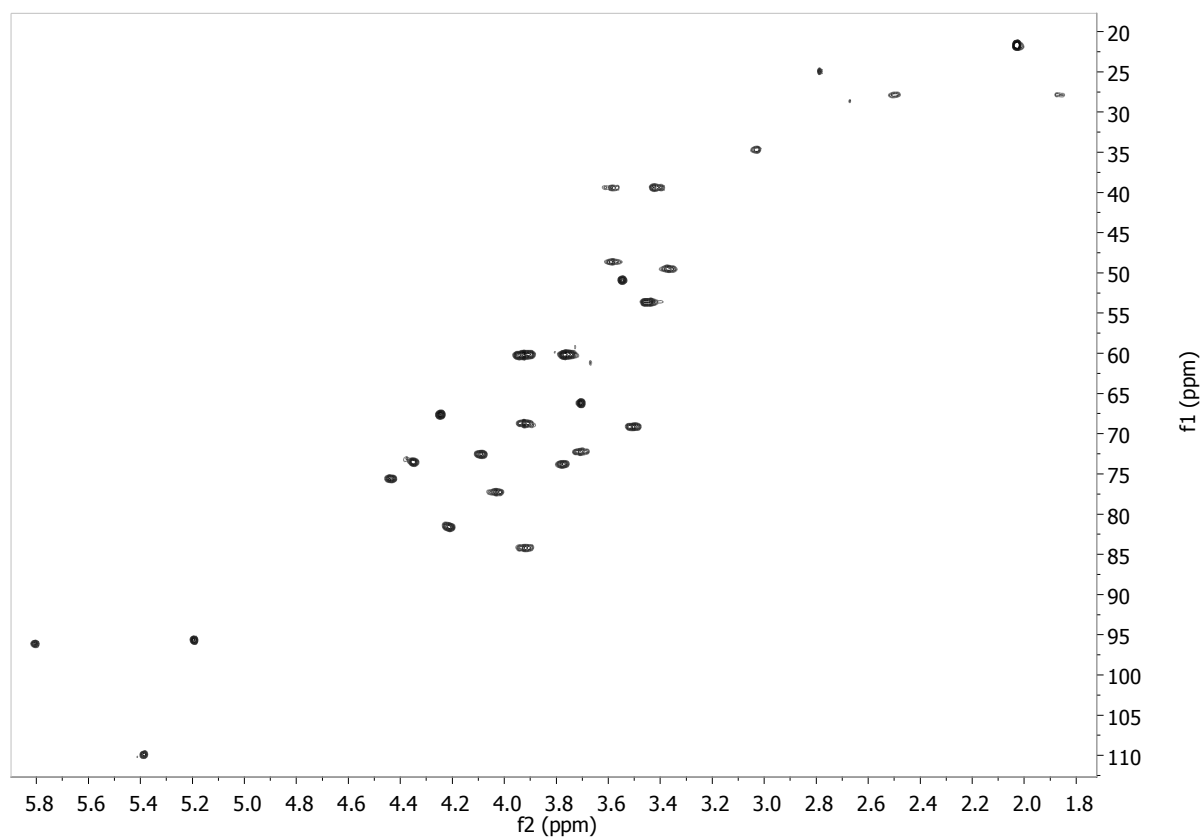

Figure 2.9b: $^1\text{H-NMR}$ (500 MHz, D_2O) spectrum of 6'''-*N*-acetyl paromomycin x 4 HFBA 7.

2.4.5 Comparison of 2D-NMR & Attached Proton Test (APT)

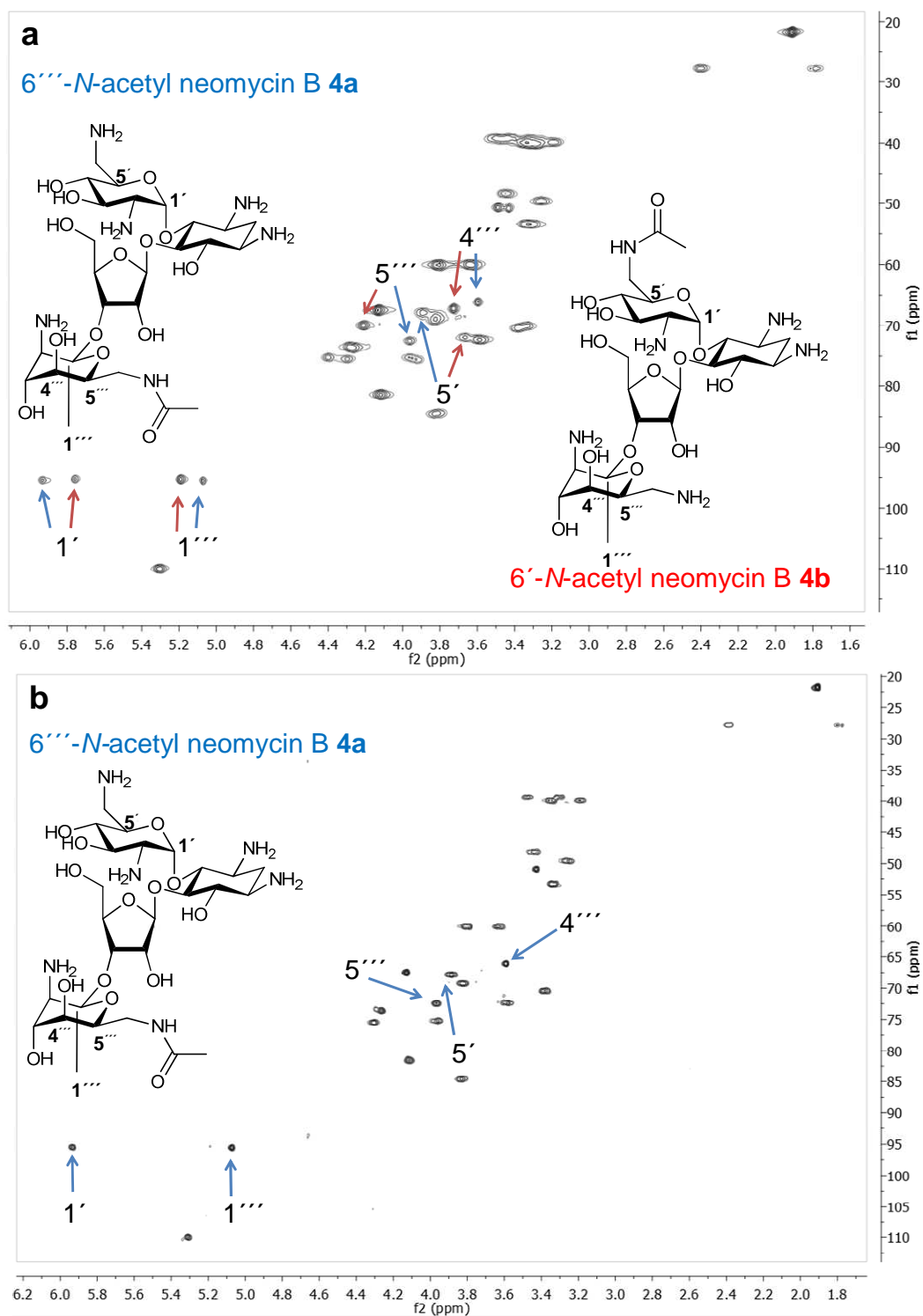

Figure 2.10: HSQC (500 MHz, D₂O) spectra of the isomeric mixture of *mono*-acetylated neomycin B derivatives obtained without APG (a) and of 6'''-N-acetyl neomycin B x 5 HFBA **4a** produced in the presence of APG **apt1** (b). Duplication of signals proves the formation of mainly two *mono*-acetylated neomycin B isomers, i.e. the 6'''-N-acetyl neomycin B **4a** and 6'-N-acetyl neomycin B **4b**, when no APG was employed. In contrast, utilization of **apt1** as APG resulted in only one detectable regioisomer **4a**.

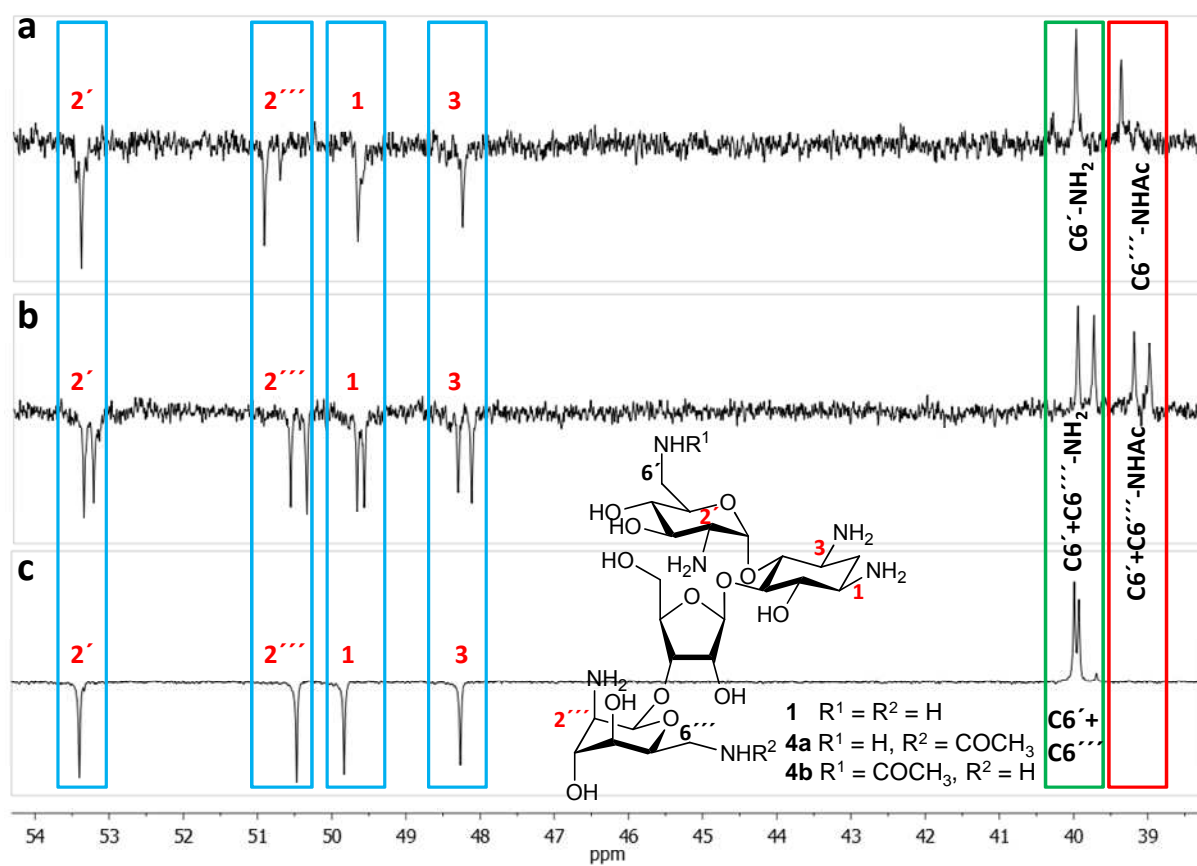

Figure 2.11: Attached Proton Tests (APT, 500 MHz, D₂O) of *mono*-acetylated derivatives after transformation of neomycin B (**1**) in presence of **apt1** (a) and in absence of APG (b) using NHS ester **3a**. APT of Neomycin B (c). Spectrum a) proves regioselective transformation of the amino group in C6 position at ring IV of neomycin B **1** resulting in derivative **4a**, while the spectrum b) shows the presence of two *mono*-acetylated Neomycin B derivatives, 6'''-*N*-acetyl neomycin B **4a** and 6'-*N*-acetyl neomycin B **4b**.

2.4.6 HPLC Analysis of Regioselective Acylation Reaction of Antibiotics

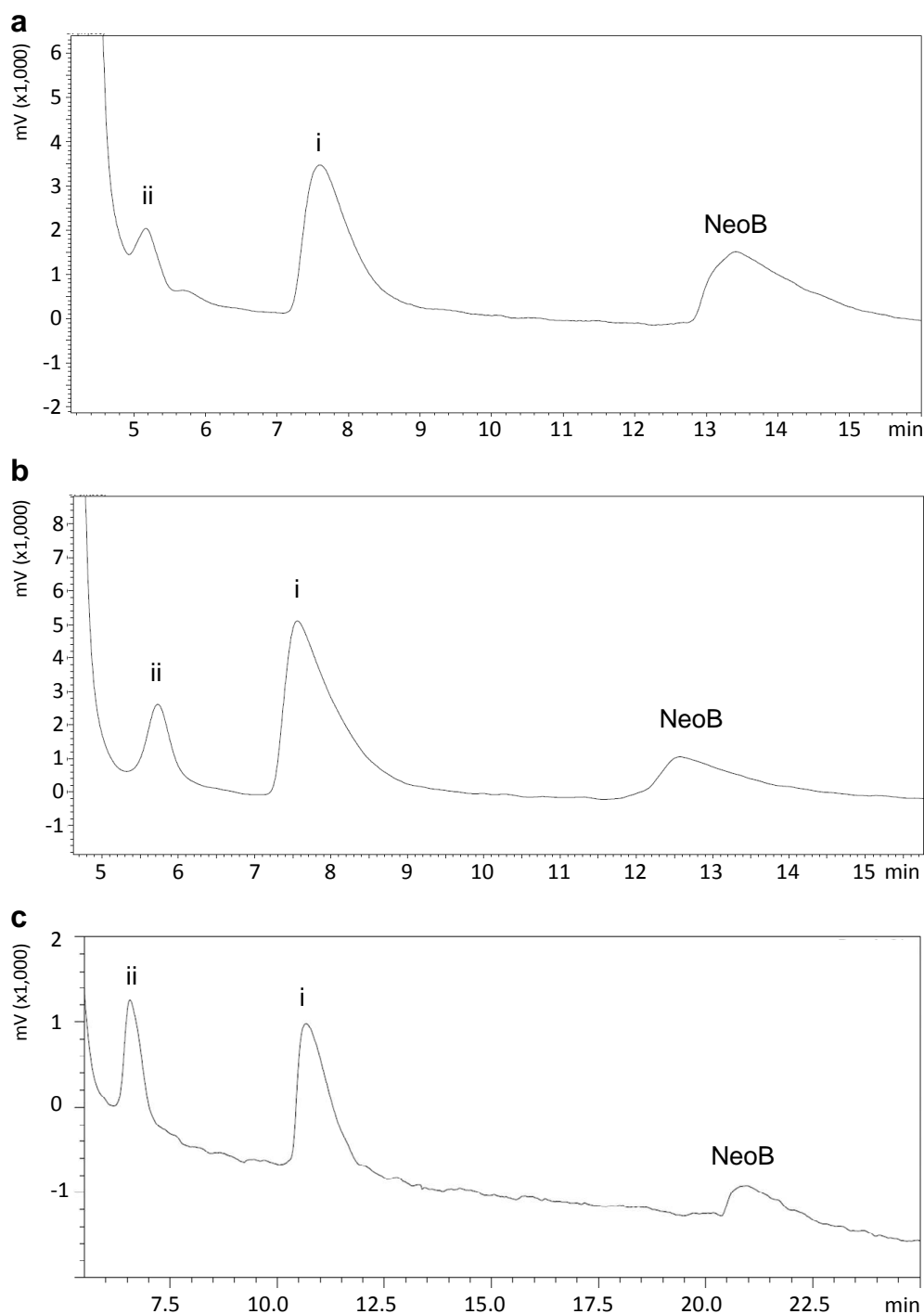

Figure 2.12: HPLC elugrams of reaction mixture after transformation of neomycin B (**1**, NeoB) using 30 equiv. of activated ester **3a** in presence of 1.5 equiv. APG **apt1** (a), **apt2** (b) and **apt3** (c) (i-ii = number of reacted amino groups of **1**). APGs **apt1** and **apt2** were precipitated, while **apt3** was hydrolyzed.

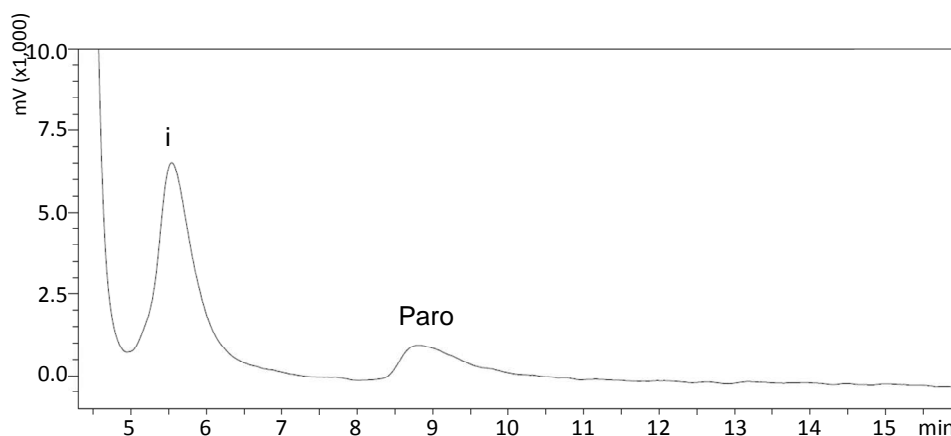
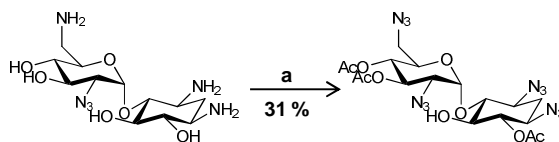

Figure 2.13: HPLC elugram of reaction mixture after transformation of paromomycin (**2**, Paro) using 30 equiv. of activated ester **3a** in presence of 1.5 equiv. APG **apt1** (i = one amino group is acetylated). Hydrolysis of the RNA was employed.

2.4.7 Conventional Synthesis of Neomycin B Modified at Ring IV

The synthesis of neomycin B derivatized at ring IV (Scheme 2.2-2.6) was performed by *P. B. Alper et al.* and *D. Semeria et al.*:^{3,29}



Scheme 2.2: Synthesis of building block I

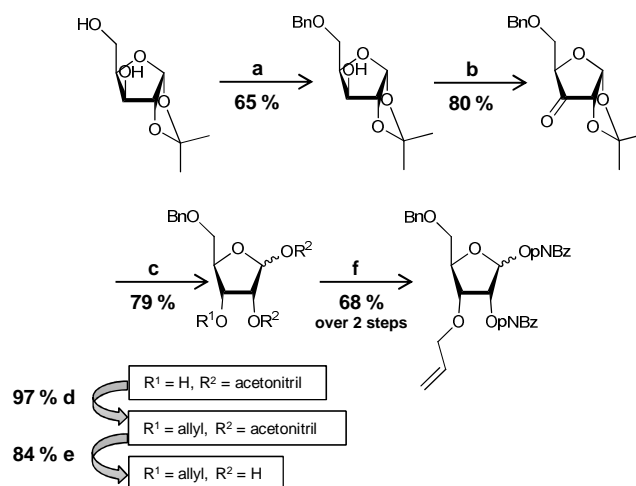

Scheme 2.3: Synthesis of building block II

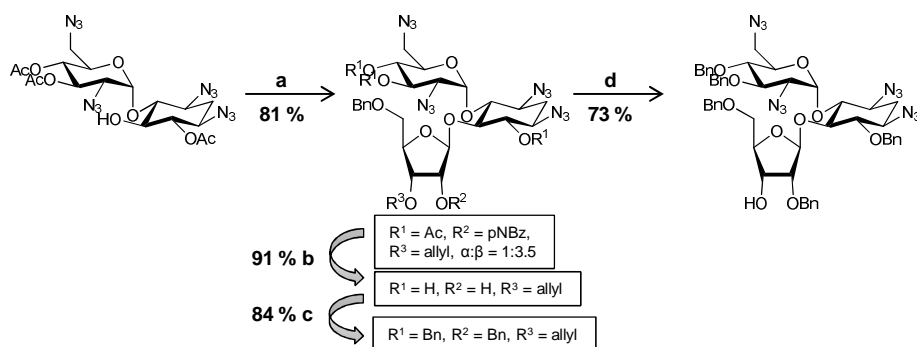

Scheme 2.4: Connection of building block I and II

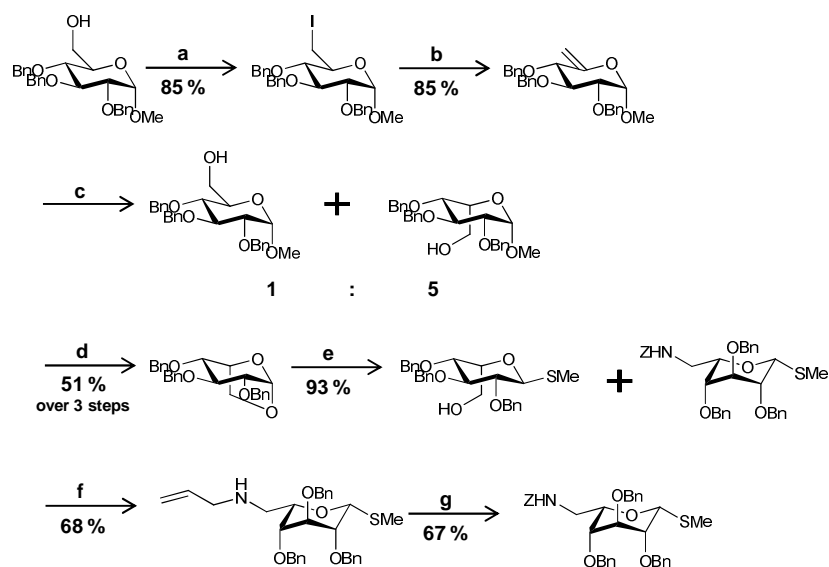

Scheme 2.5: Synthesis of building block III

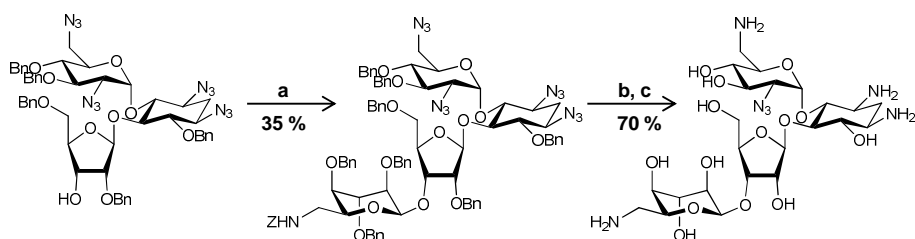

Scheme 2.6: Connection of building blocks I+II and III

2.5 References

- 1 Koehn, F. E., Carter, G. T. The evolving role of natural products in drug discovery. *Nature* **4**, 206-220 (2005).
- 2 Jesse, W.-H., Vederas, J. C. Drug discovery and natural products: End of an era or an endless frontier. *Science* **325**, 161-165 (2009).
- 3 Alper, P. B., Hendrix, M., Sears, P. & Wong, C. H. Probing the specificity of aminoglycoside ribosomal RNA interactions with designed synthetic analogs. *J. Am. Chem. Soc.* **120**, 1965-1978 (1998).
- 4 Usui, T. & Umezawa, S. Total synthesis of neomycin B. *Carbohydr. Res.* **174**, 133-143 (1988).
- 5 Hanessian, S., Szychowski, J., Pineda, N., Furtos, A. & Keillor, J. W. 6-Hydroxy to 6'''-amino tethered ring-to-ring macrocyclic aminoglycosides as probes for APH(3')-IIIa kinase. *Bioorg. Med. Chem. Lett.* **17**, 3221-3225 (2007).
- 6 Stoltenburg, R., Reinemann, C., Strehlitz, B. SELEX-A (r)evolutionary method to generate high-affinity nucleic acid ligands. *Biomol. Eng.* **24**, 381-403 (2007).
- 7 Gold, L., Polisky, B., Uhlbeck, O., Yarus, M. Diveristy of oligonucleotide functions. *Annu. Rev. Biochem.* **64**, 763-797 (1995).
- 8 Ellington, A. D., Szostak, J. W. *In vitro* selection of RNA molecules that bind specific ligands. *Nature* **346**, 818-822 (1990).
- 9 Wallis, M. G., von Ahsen, U., Schroeder, R., Famulok, M. A novel RNA motif for neomycin recognition. *Chem. Biol.* **2**, 543-552 (1995).
- 10 Famulok, M. & Szostak, J. W. Stereospecific recognition of tryptophan agarose by *in vitro* selected RNA. *J. Am. Chem. Soc.* **114**, 3990-3991 (1992).
- 11 Famulok, M. Molecular recognition of amino-acids by RNA-apatmers - an L-citrulline binding RNA motif and its evolution into an L-arginine binder. *J. Am. Chem. Soc.* **116**, 1698-1706 (1994).
- 12 Sassanfar, M. & Szostak, J. W. An RNA motif that binds ATP. *Nature* **364**, 550-553 (1993).
- 13 Li, Y. F., Geyer, C. R. & Sen, D. Recognition of anionic porphyrins by DNA aptamers. *Biochemistry* **35**, 6911-6922 (1996).
- 14 Wang, K. Y., McCurdy, S., Shea, R. G., Swaminathan, S. & Bolton, P. H. A DNA aptamer which binds to and inhibits thrombin exhibits a new structural motif for DNA. *Biochemistry* **32**, 1899-1904 (1993).
- 15 Betat, H. *et al.* Aptamers that recognize the lipid moiety of the antibiotic moenomycin A. *Biol. Chem.* **384**, 1497-1500 (2003).
- 16 Jiang, L. C. *et al.* Saccharide-RNA recognition in a complex formed between neomycin B and an RNA aptamer. *Struct. Fold. Des.* **7**, 817-827 (1999).
- 17 Cowan, J. A., Ohyama, T., Wang, D. Q. & Natarajan, K. Recognition of a cognate RNA aptamer by neomycin B: Quantitative evaluation of hydrogen bonding and electrostatic interactions. *Nucleic. Acids. Res.* **28**, 2935-2942 (2000).
- 18 Purohit, P. & Stern, S. Interactions of small RNA with antibiotic and RNA ligands of the 30S subunit. *Nature* **370**, 659-662 (1994).

- 19 Moazed, D. & Noller, H. F. Interaction of antibiotics with functional sites in 16S ribosomal-RNA. *Nature* **327**, 389-394 (1987).
- 20 Francois, B. *et al.* Crystal structures of complexes between aminoglycosides and decoding A site oligonucleotides: Role of the number of rings and positive charges in the specific binding leading to miscoding. *Nucleic. Acids. Res.* **33**, 5677-5690 (2005).
- 21 Zhou, J., Wang, G., Zhang, L. H. & Ye, X. S. Modifications of aminoglycoside antibiotics targeting RNA. *Med. Res. Rev.* **27**, 279-316 (2007).
- 22 Zhang, J. J. *et al.* Surprising alteration of antibacterial activity of 5"-modified neomycin against resistant bacteria. *J. Med. Chem.* **51**, 7563-7573 (2008).
- 23 Stampfl, S., Lempradl, A., Koehler, G. & Schroeder, R. Monovalent ion dependence of neomycin B binding to an RNA aptamer characterized by spectroscopic methods. *Chem. Bio. Chem.* **8**, 1137-1145 (2007).
- 24 Coqui re, D., de la Lande, A., Paris l, O., Prang , T. & Reinaud, O. Directional control and supramolecular protection allowing the chemo- and regioselective transformation of a triamine. *Chem.-Eur. J.* **15**, 11912-11917 (2009).
- 25 Cafeo, G., Kohnke, F. H. & Valenti, L. Regioselective O-alkylations and acylations of polyphenolic substrates using a calix[4]pyrrole derivative. *Tetrahedron Letters* **50**, 4138-4140 (2009).
- 26 Grapsas, I., Massova, M., Mobashery, S. ¹H-NMR analysis of copper-aminoglycoside complexes in solution and its implication for regioselective modification of multifunctional aminoglycoside antibiotics. *Tetrahedron* **54**, 7705-7720 (1998).
- 27 Jacobson, K. A., Kirk, K. L., Padgett, W. L., Daly, J. W. Functionalized congeners of adenosine: Preparation of analogs with high affinity for A1-adenosine receptors. *J. Med. Chem.* **28**, 1346-1350 (1985).
- 28 Calvet, G., Blanchard, N. & Kouklovsky, C. Domino metathesis of 3,6-dihydro-1,2-oxazine: Access to isoxazolo[2,3-*a*]pyridin-7-ones. *Org. Lett.* **9**, 1485-1488 (2007).
- 29 Semeria, D., Philippe, M., Delaumeny, J. M., Sepulchre, A. M. & Gero, S. D. A general-synthesis of cyclitols and aminocyclitols from carbohydrates. *Synthesis*, 710-713 (1983).

Chapter 3

Elucidation of the Mode of Action of Aptameric Protective Groups

In the previous chapter, aptameric protective groups (APGs) have been utilized for regioselective derivatization of natural products. The application of different RNA sequences as APGs was proven to be highly efficient in regioselective one-step-modifications of the multifunctional aminoglycoside antibiotics neomycin B and paromomycin carrying several chemically equivalent amino- and hydroxy groups. However, since RNA aptamers are known to have more than one binding site for these antibiotics, the mode of action needs to be elucidated in more detail. Herein, a model was developed that explains the regioselective outcome of these transformations. In particular we demonstrate that some aptamers bind the antibiotics in such a way that different protection modes are realized. With the help of our studies the reaction conditions can be adjusted to obtain antibiotic derivatives with maximum regioselectivities.

1. Introduction

In 2009 supramolecular protective groups (SPGs) based on macrocycles were applied for the regioselective derivatization of small molecules.^{1,2} Non-covalent interactions between the SPG (host) and the guest molecule exhibiting multi functional groups allowed the protection of several of these, while functionalities not in contact with the host could be transformed regioselectively. However, SPGs based on macrocycles exhibit serious limitations. The small cavity size for the host allows so far only complexation of small, *di*- or *tri*-functional molecules, such as 7-hydroxy naphthol¹ and *N*-(2-aminoethyl)propane-1,3-diamine.² Furthermore, these SPGs require elaborate design and synthesis for each guest molecule.^{1,2} To overcome these limitations, in the first chapter we have introduced a novel class of non-covalent protective groups based on RNA sequences, so called **aptameric protective groups** (APGs), allowing highly regioselective derivatization of the structurally complex antibiotics neomycin B **1** and paromomycin **2** (Fig. 3.1a). APGs were successfully applied to protect several functional groups within guest molecules **1** and **2** allowing chemo- and regioselective transformations of antibiotic's ring IV. RNA molecules are well suited as APGs as they can be generated via the well established *in vitro* evolution process SELEX (**S**ystematic **E**volution of **L**igands by **E**Xponential **E**nrichment). Moreover, RNA aptamers have been selected against a broad range of multiply functionalized guest molecules, such as carbohydrates,^{3,4,5,6} unpolar lipids,⁷ enzymes,⁸ amino acids,^{9,10,11,12} steroids,¹³ and aromatic molecules, such as catecholamines,¹⁴ machalit green and tetramethylrosamine.¹⁵ Their specific host-guest recognition abilities were already successfully used in bioanalytic,¹⁶ diagnostic and therapeutic^{17,18,19} applications. However, in contrast to SPGs based on macrocycles,^{1,2} APGs can exhibit more than one recognition site for guest molecules, as demonstrated for aminoglycosides.^{20,21,22} As a result, different protection modes for guest molecule can be expected resulting in a mixture of regioisomers after transformation. During the last years the recognition mode between a 23mer RNA aptamer **apt1** (5'-GGA CUG GGC GAG AAG UUU UGA CC-3') and neomycin B were investigated in detail. After the structure of the **1** - **apt1** complex (Fig. 3.1b) was solved by NMR spectroscopy,⁴ Stampfl *et al.* demonstrated that the sequence of **apt1** exhibits three binding pockets for **1**, of which two exhibit high affinity to neomycin B.²⁰ Despite the presence of several binding sites, high regioselectivities in derivatization of the amino group in C6 position of ring IV of **1** and **2** were achieved using *N*-hydroxysuccinimide (NHS) esters (chapter 2). However, the formation of other regioisomers under certain reaction conditions could not be avoided limiting the regioselectivity of the

modification. Therefore, the mode of action of APGs exhibiting more than one recognition site for **1** needed to be elucidated.

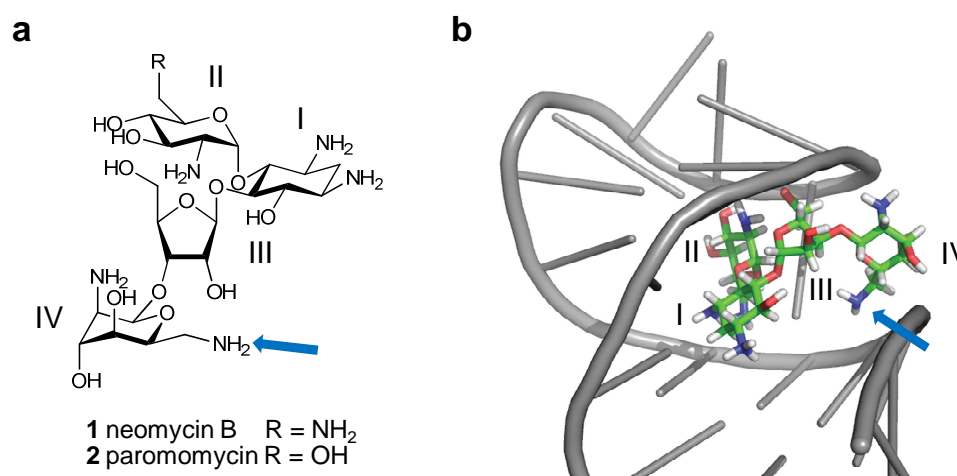

Figure 3.1: **a**, Structure of representative aminoglycoside antibiotics. **b**, APG **apt1** selectively protecting neomycin B⁴ (Color coding: white – hydrogen, green – carbon, red – oxygen, blue – nitrogen). Blue arrow indicates the amino group accessible for regioselective acylation (chapter 2).

3.2 Results & Discussion

3.2.1 RNA Aptamers as APGs & Their Binding Sites.

In this study we applied the RNA sequences **apt1** (23mer), **apt2** (21mer) and **apt3** (36mer) as APGs for neomycin B (Fig. 3.2). All these sequences were selected by SELEX by *Wallis* and coworkers.²³ It has to be mentioned that during the selection of the aptamers aminoglycoside **1** was randomly immobilized on solid support using its amino groups in C6 position at ring II and IV.²³ Therefore, at least two interaction modes were expected between the antibiotic **1** and chosen RNA sequences: In one binding mode rings I, II and III are shielded allowing reactions on ring IV while in the other mode rings I, III and IV are protected facilitating modifications on ring II.

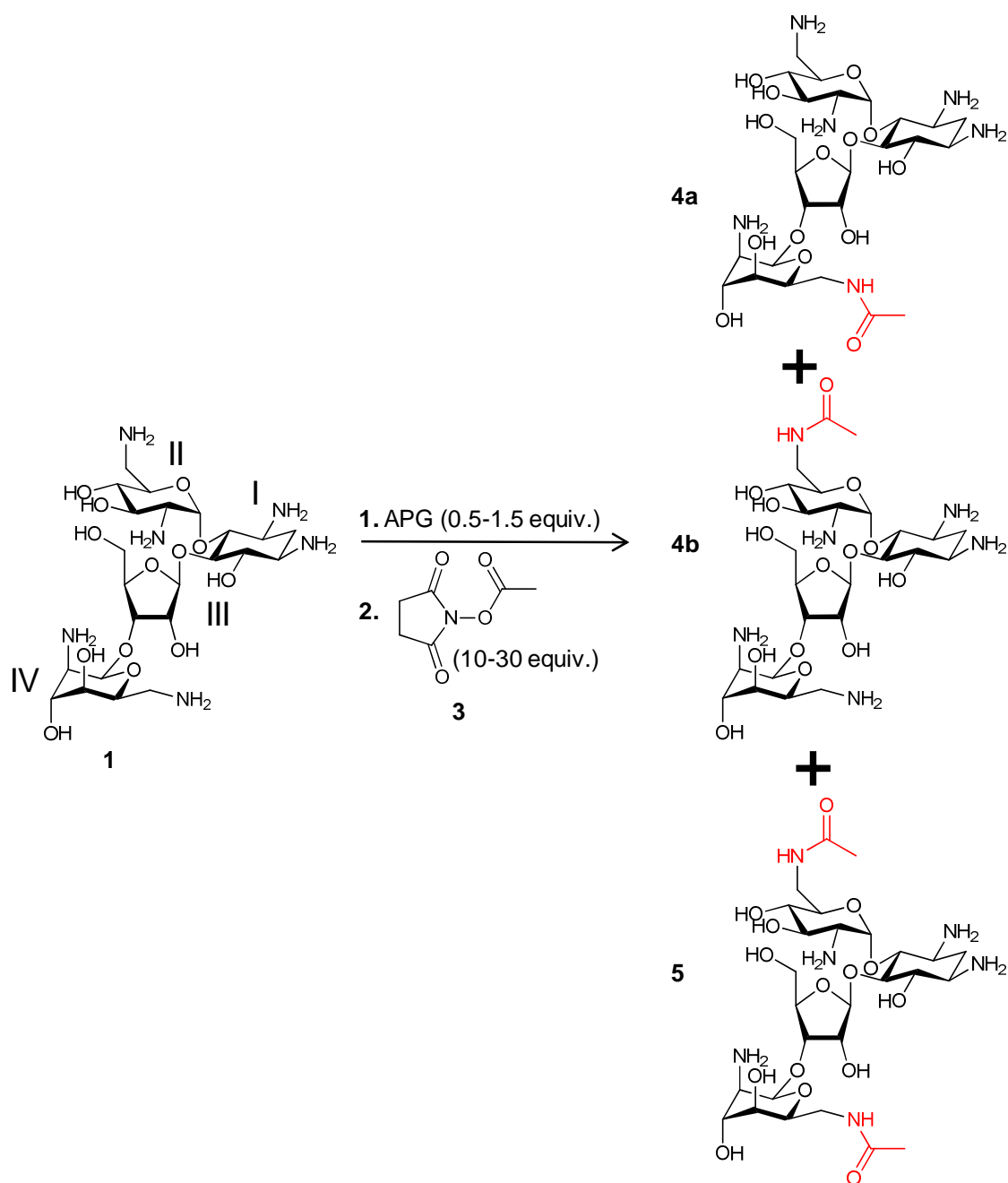

Figure 3.2: Stem-loop structures and sequences of applied APGs **apt1**, **apt2** and **apt3**.²³

To determine number and affinities of binding sites for antibiotic **1** of sequences **apt1**, **apt2** and **apt3** Isothermal Titration Calorimetry (ITC) experiments were performed (see experimental part 3.5.6). These, ITC experiments indicated the presence of two binding sites within all sequences exhibiting high affinity for neomycin B (see additional experimental part Table 3.4). The results show that the affinity difference between the two present binding sites within **apt1** ($K_{a,1} = 1.542 \times 10^9 \text{ M}^{-1}$, $K_{a,2} = 3.3 \times 10^6 \text{ M}^{-1}$) and **apt2** ($K_{a,1} = 2.33 \times 10^8 \text{ M}^{-1}$; $K_{a,2} = 1.9 \times 10^6 \text{ M}^{-1}$) is more than two orders of magnitude. In contrast, the difference of affinity for the antibiotic **1** within **apt3** is only one order of magnitude ($K_{a,1} = 62 \times 10^6 \text{ M}^{-1}$, $K_{a,2} = 1.2 \times 10^6 \text{ M}^{-1}$) assuming that this sequence also exhibits two high-affinity binding sites. However, from these ITC measurements it can be concluded that two antibiotic molecules can bind to a single aptamer (**apt1**, **apt2** and **apt3**) with high affinities.

3.2.2 Dependence of Regioselectivity on APG/Antibiotic Ratio

After proving the presence of two binding sites for neomycin B within sequences **apt1**, **apt2** and **apt3**, the protection mode of **1** by these APGs was investigated. Therefore, antibiotic **1** was complexed with sequences **apt1**, **apt2** and **apt3** and reacted subsequently with a large excess of NHS ester **3** (10-30 equiv.) to identify reactive, unprotected amine groups of **1** (Scheme 3.1). After transformation the resulting products were purified by High Performance Liquid Chromatography (HPLC) and characterized using mass spectrometry and NMR spectroscopy. As shown in Scheme 3.1, in presence of the aptamers the transformation of **1** with acetyl activated ester **3** resulted in the formation of mainly *mono*-acetylated neomycin B derivatives **4a**, **4b** and diacetylated antibiotic **5**. In absence of APGs aminoglycoside **1** is transformed into *tetra*- up to *hexa*-acetylated neomycin B derivatives (chapter 2, Fig. 2.2). It needs to be noted that besides the *di*-acetyl neomycin B **5** other regioisomers exhibiting two acetyl groups were formed in minor amounts (see experimental part Fig. 3.8). Moreover, based on the result obtained in chapter 2 and 4, in the following experiments it is assumed that exclusively *mono*- and *di*-acetylated derivatives are formed in presence of an APG. However, due to the fact that **4a** (acetylation product at ring IV, desired product) and **4b** (acetylation product at ring II) cannot be separated by HPLC, the ratios of *mono*-acetylated regioisomers **4a** and **4b** were determined by NMR spectroscopy. From the NMR spectra the regioselectivities of the formation of **4a** were calculated.



Scheme 3.1: Transformation of neomycin B in presence of APG (**apt1**, **apt2** and **apt3**) applying an excess of NHS ester **3** in 10mM sodium phosphate buffer solution (pH \approx 7) at room temperature.

To investigate the influence of the different binding sites of **apt1** and **apt2** on the regioselectivity different APG/1 ratios were applied for the transformation using activated ester **3**, i.e. 0.5, 1.0 and 1.5. Applying a ratio of 1.5 one can assume that neomycin B is exclusively present within the binding site with higher affinity whereas at a ratio of 0.5 both binding sites are occupied by the antibiotic **1**. In Figure 3.3 sections of the $^1\text{H-NMR}$ spectra of the isolated *mono*-acetylated products for these reactions are given. From these spectra the

corresponding regioselectivities for the transformations were calculated. As shown in Figure 3.3, with increasing APG/neomycin B ratios the reaction seemed to proceed with higher regioselectivities (for **apt1**: from 88 % to 96 % and for **apt2**: from 88 % to 93 %). This also means, that when both binding sites of **apt1** and **apt2** are occupied, (APG/1 ratio = 0.5) more side product **4b** is formed. Moreover, with lower amounts of APG the conversion of neomycin B to diacetylated antibiotic **5** increased from 5 % to 28 %, using 1.5 and 0.5 equiv. **apt1**, respectively (Table 3.1). Similar results were obtained applying **apt2** as APG (Table 3.1). This is a strong hint that *di*-acetylation of neomycin B resulting in formation of **5** is happening predominantly in the low affinity binding site whereas **4a** originates from transformation of **1** in the high affinity binding site. The fact that both aptamers, **apt1** and **apt2**, show a similar behavior can be explained by similar protection of neomycin B by these two sequences, which is supported by comparable binding affinities as determined by the ITC measurements (paragraph 3.2.1) and NMR studies (Fig. 3.3).

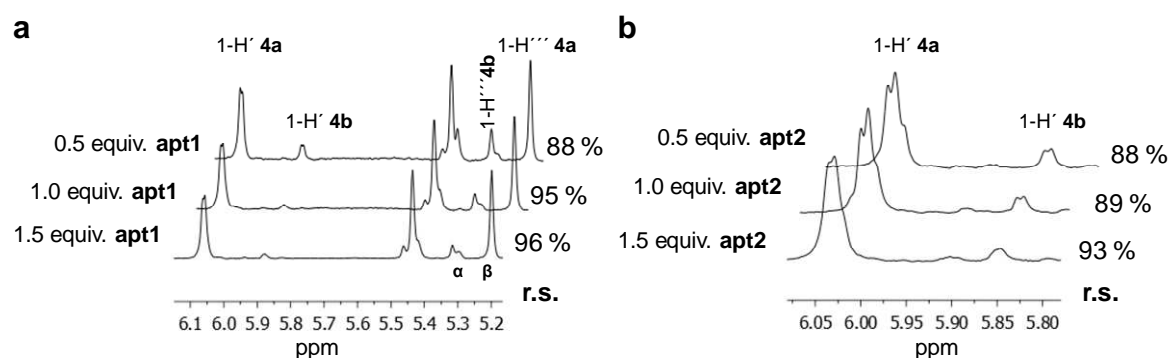

Figure 3.3: Section of ^1H -NMR (500 MHz, D_2O) spectra of *mono*-acetylated isomer mixtures (**4a**, **4b**) in dependence of the APG/1 ratio (**apt1** (a) and **apt2** (b)). The NMR signal of the anomeric proton of ring IV of regioisomer **4a** is splitting into two (5.20 ppm, β -anomer; 5.30 ppm, α -anomer) due to anomerisation. Regioselectivities (r.s.) were calculated from the integrals of the anomeric protons of ring II of the regioisomers **4a** and **4b**.

In contrast, the transformation of **1** in presence of **apt3** results mainly in a mixture of **4a**, **4b** and **5** in similar amounts (Table 3.1). This result suggests that both binding sites exhibiting similar affinities have a different protection mode for neomycin B, or antibiotic **1** can interact differently with each binding site. However, it seems that lower affinity differences between the binding sites ($K_{a,1}$ and $K_{a,2}$) within one RNA aptamer cause lower ratios of yielded regioisomers **4a** and **4b** during acetylation. This gave rise to lower regioselectivities in order to form **4a** (Table 3.1).

Table 3.1: Dependence of the formation of **4a**, **4b** and **5** on the APG/neomycin B ratio.

APG	equiv. APG	1 [^] (%)	4a [*] (%)	4b [*] (%)	5 [^] (%)
apt1 ^{**}	0.5	25	41	6	28
apt1	1.0	39	51	3	7
apt1 ^{**}	1.5	44	48	3	5
apt2 ^{**}	0.5	27	33	5	35
apt2	1.0	53	36	4	7
apt2 ^{**}	1.5	49	42	3	6
apt3 ^{**}	1.5	9	29	37	25

Reactions were performed according to the general procedure using 30 equiv. activated ester **3** (experimental part 3.5.2). [^] Conversions of **1** to *di*-acetyl neomycin B **5** and the unconverted amounts of **1** were determined by analytical HPLC (see experimental part Fig. 3.11). ^{*} Conversions of **1** to **4a** and **4b** were calculated from the mixture of *mono*-acetyl derivatives (**4a** and **4b**) applying integrals of HPLC and corresponding ¹H-NMR peaks (Fig. 3.3). ^{**} Experiments were repeated up to five times and an error of the conversion was calculated to be of up to 6 %; it is assumed that only *mono*- and *di*-acetylated derivatives were formed and the error of all experiments are in the same range.

3.2.3 Dependence of Regioselectivity on Reaction Time

To get a better understanding of the protection mode of the individual binding sites within **apt1** and **apt2**, the evolution of formation of **4a**, **4b** and **5** was investigated over time in presence of 0.5 equivalents of APG. As shown in Table 3.2, regioisomers **4a** and **4b** are formed immediately after one minute reaction time, while the formation of the *di*-acetyl neomycin B **5** is considerably slower. Furthermore, with longer reaction time the formation of the *mono*-acetyl regioisomer **4a** and the *di*-acetyl derivative **5** was increased, while the amount of isomer **4b** was reduced significantly (Table 3.2). As demonstrated in Figure 3.4, the ¹H-NMR spectra show a significant increase of the regioisomer **4a/4b** ratio with increased reaction time. It has to be mentioned that a slightly reduced amount of derivative **5** was observed for **apt2** after long reaction time (24 hours). This can be explained by the formation of higher acetylated products using **apt2** as APG (see experimental part Fig. 3.10). However, from these observations two conclusions can be drawn: (1) During the reaction a significant amount of **4b** is formed (see short reaction times); (2) a major part of *mono*-acetylated neomycin B **4b** is further converted to antibiotic derivative **5** exhibiting two acetyl groups.

Taking into account that **4a** is mainly formed in the high affinity binding site (*vide supra*) one can conclude that **4b** predominantly originates from the low affinity binding site of **apt1** and **apt2**. These conclusions are also supported by the result reported in Table 3.1. The higher the APG/antibiotic **1** ratio is, the less of **1** is present in the low affinity binding site resulting in minimized formation of **4b** and **5** during modification of neomycin B.

Table 3.2: Dependence of the formation of 4a, 4b and 5 on the reaction time.

APG	equiv. APG	1 [^] (%)	4a* (%)	4b* (%)	5 [^] (%)
apt1	1 min	69	15	10	6
apt1	20 min	38	29	10	23
apt1	2 h	30	37	7	26
apt1	24 h	23	45	4	28
apt2	1 min	44	22	19	15
apt2	20 min	24	25	13	38
apt2	2 h	21	30	8	41
apt2	24 h	24	35	4	37

Reactions were performed according the general procedure using 10 equiv. activated ester **4** (see experimental part 3.5.2). [^] Conversions of **1** to *di*-acetyl neomycin B **5** and the unconverted amounts of **1** were determined by analytical HPLC (see experimental part Fig. 3.12). * Conversions of **1** to **4a** and **4b** were calculated from the mixture of *mono*-acetyl derivatives (**4a** and **4b**) applying integrals of HPLC and corresponding ¹H-NMR peaks (Fig. 3.4). It is assumed that only *mono*- and *di*-acetylated derivatives were formed and the conversion error is expected to be in the range of 6 % (based on similarity to the results shown in Table 3.1). For each aptamer one reaction was carried out, from which aliquots were taken after 1min, 20 min, 2 h and 24 h for HPLC- and ¹H-NMR studies.

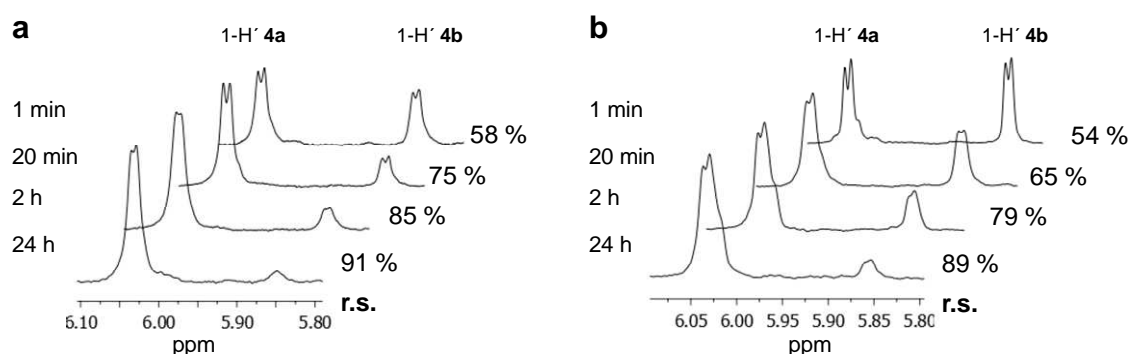

Figure 3.4: Section of ¹H-NMR (500 MHz, D₂O) spectra of *mono*-acetylated isomer mixtures (**4a**, **4b**) dependent on reaction times using **apt1** (a) and **apt2** (b) as APG. Regioselectivities (r.s.) were calculated from ¹H-NMR peak integrals of regioisomers **4a** and **4b**.

3.2.4 Dependence of Regioselectivity on Salt Concentration & Temperature

Finally, it needs to be investigated why **4b** and **5** are formed even when an excess of APG is employed. Therefore, we studied whether the amine group in C6 position of ring II is also reactive in the high affinity binding site as indicated by the low amounts of **4b** and **5** formed at a high APG/**1** ratio (Table 3.1). The **apt1**-antibiotic **1** complex (ratio APG/**1** = 1.5) was formed as for the reactions above at a sodium ion concentration of 10 mM. Since the complex stability is reduced with the increase of salinity²⁰, concentrated aqueous NaCl solution (231 mM and 578 mM) was added subsequently to reach a final sodium concentration of 30 and 60 mM. Then, the complex was again reacted with 30 equivalent of activated ester **3** and the regioselectivities of the monoacetylation of antibiotic's ring IV in presence of 10, 30 and 60 mM sodium concentration were calculated from NMR spectra (Fig. 3.5). Employing ¹H-NMR spectroscopy the antibiotic derivatives **4a** and **4b** were the only *mono*-acetylated neomycin B regioisomers which were detected. Moreover, the spectra presented in Figure 3.5 show an increase of the portion of **4b** with higher salt concentration resulting in a decrease of regioselectivities to 85 % and 81 % for 30 mM and 60 mM concentration, respectively (at 10 mM regioselectivity = 94 %). This result indicates that the amino group in C6 position at ring II is also reactive in the high affinity binding site of **apt1** resulting in **4b** as side product. Therefore, it can be concluded that the minor reactivity of ring II is limiting the regioselectivity of the acetylation reaction of ring IV to 94 % at a salinity of 10 mM. This result is also in agreement with previous findings that the regioselectivity is dependent on the

size of the residue introduced at the amine group of ring IV (chapter 2). It was observed that sterically more demanding residues result in higher regioselectivities (isopropyl and 3-butynyl gave 97 % and 98 % regioselectivities, respectively) indicating the minor reactivity of ring II in the high affinity binding site.

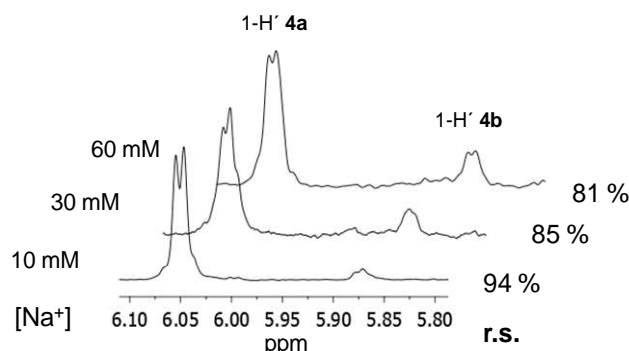

Figure 3.5: Section of $^1\text{H-NMR}$ (500 MHz, D_2O) spectra of *mono*-acetylated isomer mixtures (**4a**, **4b**) dependent on sodium concentration using **apt1** as APG. Regioselectivities (r.s.) were calculated from the integrals of the anomeric protons of ring II of the regioisomers **4a** and **4b**.

However, in contrast to *mono*-acetylated derivative **4b** the formation of *di*-acetyl neomycin B **5** was not increasing significantly with higher salinity (8 % at 60 mM $[\text{Na}]^+$). Therefore, to test whether derivative **5** can also be formed in the high affinity binding site the reaction was performed again using 1.5 equivalents of APG **apt1** but applying higher reaction temperatures to destabilize more the complex (Table 3.3).

Table 3.3: Dependence of the formation of 4a, 4b and 5 on the reaction temperature.

temp. (°C)	1 [^] (%)	4a* (%)	4b* (%)	5 [^] (%)	r.s. (%)
20	59	35	2	3	94
40	43	42	5	10	90
50	24	55	5	16	92

Reactions were performed according the general procedure using 30 equiv. activated ester **3** (see experimental part 3.5.2). [^] Conversions of **1** to *di*-acetyl neomycin B **5** and the unconverted amounts of **1** were determined by analytical HPLC (see experimental part Fig. 3.13). * Conversions of **1** to **4a** and **4b** were calculated from the mixture of *mono*-acetyl derivatives (**4a** and **4b**) applying integrals of HPLC and corresponding $^1\text{H-NMR}$ peaks. It is assumed that only *mono*- and *di*-acetylated derivatives were formed.

As shown in Table 3.3, employing a reaction temperature of 40 °C and 50 °C the conversion of neomycin B to *di*-acetyl neomycin B **5** is increasing to 10 % and 16 %, respectively. From these observations we can conclude that **5** can also be formed in minor amounts in the high affinity binding site.

3.3 Mode of Action of Aptameric Protective Groups

Based on all presented results the suggested mode of action of APGs (**apt1** and **apt2**) can be summarized as followed: As shown in Scheme 3.2, neomycin B occupying the high affinity binding site is transformed predominantly into the 6''-*N*-acetyl neomycin B derivative **4a**, while in the low affinity site the *mono*-acetylated derivative **4b** is mainly formed. During the course of the reaction, derivative **4b** is further converted to the *di*-acetyl neomycin B **5** while regioisomer **4a** shows no or very little reactivity in the high affinity binding site. Therefore, 6''-*N*-acetyl neomycin B **4a** is formed as main *mono*-acetylated derivative applying **apt1** and **apt2** as APGs. Moreover, our data suggest that higher affinity difference between both binding sites for neomycin B results in higher regioselectivities.

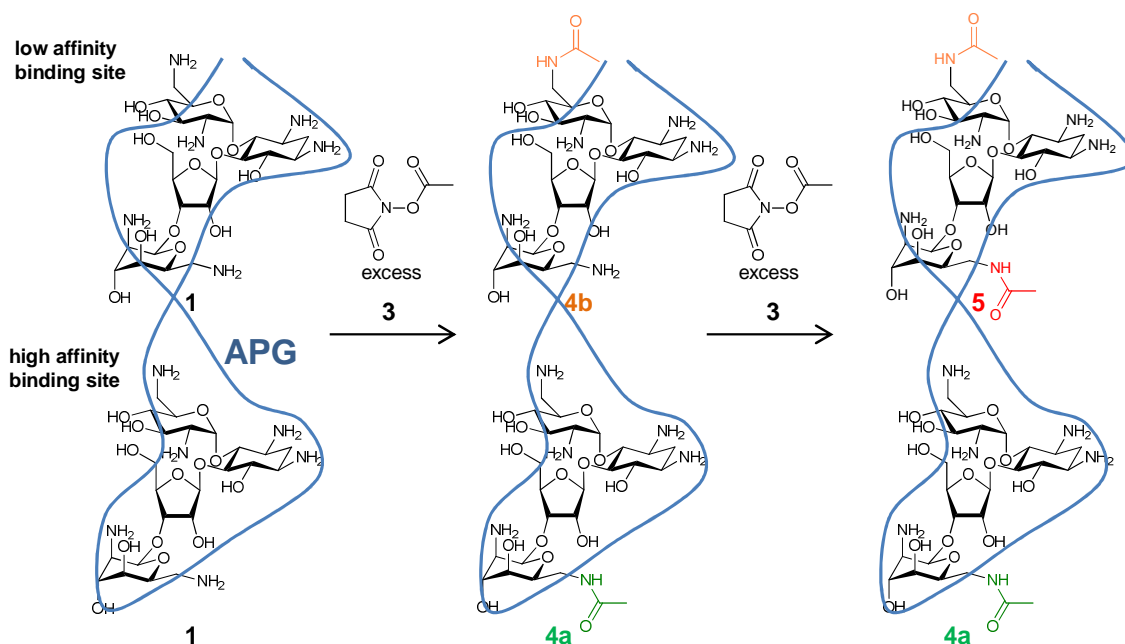

Scheme 3.2: Suggested mode of action of RNA aptamers **apt1** and **apt2** as APG exhibiting two binding sites for aminoglycoside neomycin B.

3.4 Conclusion

In this work, a model for the mode of action of APGs has been developed inducing high regioselectivities for the acylation of neomycin B. This was of particular importance since these APGs exhibit two binding sites for the antibiotic. Our studies demonstrated that different binding sites in these aptamers give rise to different protection modes of the aminoglycoside that result in two different *mono*-acylated neomycin B derivatives. Based on these findings the reaction conditions especially the aptamer/antibiotic ratio and the reaction time can be adjusted in order to obtain one of these isomers in excellent regioselectivity. Finally, our studies demonstrated that ITC measurement is a useful tool to estimate the applicability of RNA aptamers as APGs. This holds especially true when in the future SELEX will be employed for APG generation to new targets from which the structure of the RNA-target complex is unknown.

3.5 Experimental Section

3.5.1 Materials & Methods

NMR spectra were recorded on a Varian Unity Inova Varian Unity Inova (500 MHz for ^1H -NMR and HSQC, 125 MHz for APT) NMR spectrometer at 25 °C using 3 mm NMR tubes (Sigma-Aldrich). High resolution mass spectrometry (HRMS) was carried out on a LTQ ORBITRAP XL instrument (Thermo scientific) employing electron impact ionization in positive ion mode (EI+). Chromatographic separations were carried out on a Shimadzu VP series HPLC modular system (DGU-14A3 Online Vacuum-Degasser, two LC-20 AT pumps, SIL-20A auto sampler, CTP-20 A column oven, RID-10 refractive detector, FRC-10 A fraction collector and Shimadzu LCsolution software). High performance liquid chromatography (HPLC) purification was carried out with a Waters Spherisorb ODS-2 C₁₈ analytical column (250 x 4.6 mm, spherical particles of 5 μm and 80 Å pore size) using isocratic elution at 40 °C. A pH-meter (Hanna Instruments pH 209) equipped with a glass combination electrode was used for pH adjustments of the reaction buffers. All chemicals and reagents were purchased from commercial suppliers and used without further purification, unless otherwise noted. Neomycin B trisulfate x hydrate (VETRANAL[®]), *N*-hydroxysuccinimide (NHS, 98 %), trifluoroacetic anhydride (99 %), dichloromethane

(DCM, 99.5 %), tetrahydrofuran (THF, 99.9 %), pyridine (99 %), acetic acid (99 %), isobutyric acid (99 %) and toluene (99.8 %) were purchased from Sigma Aldrich and used as received. For HPLC purification heptafluorobutyric acid (HFBA) (Fluka, puriss. p.a., for ion chromatography), acetone (Sigma-Aldrich, HPLC grade) were used. Ultrapure water (specific resistance > 18.4 MΩ cm) was obtained by Milli-Q water purification system (Sartorius®). RNA aptamers (82 – 91 % of purity) were purchased from *BioSpring* (Frankfurt am Main, Germany) and riboxx GmbH (Radebeul, Germany). Acetic acid *N*-hydroxysuccinimide ester **3** was prepared according to standard literature procedures²⁴. For the preparation of the sodium phosphate buffer (10 mM, pH 6.8 and 7.4) Milli-Q water was treated with diethylpyrocarbonate (DEPC) and sterilized using an autoclave (121 °C, 20 min).

3.5.2 General Procedures for Regioselective Acylation of Neomycin B

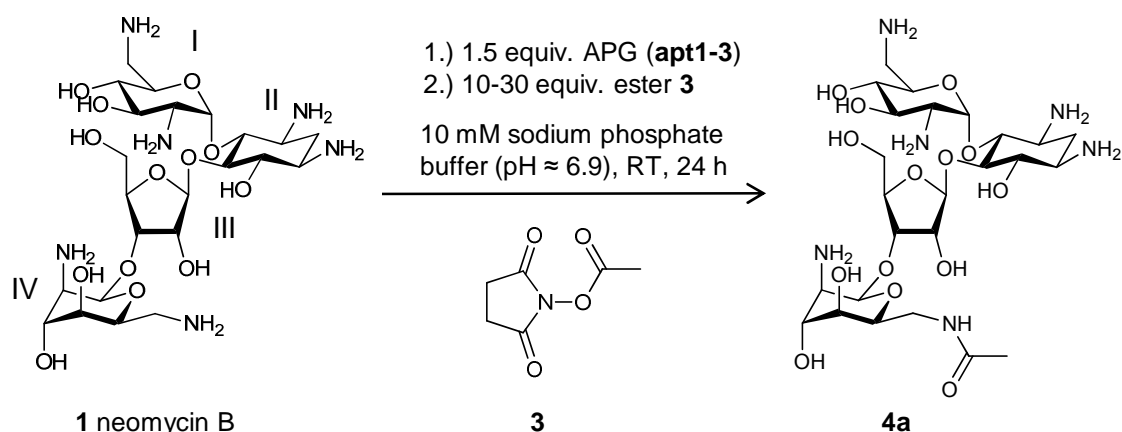

Scheme 3.3: Regioselective transformation of neomycin B **1**

a) Procedure using 0.5, 1 and 1.5 equiv. RNA aptamer.

A volume of 272 μL of a 6.1 mM (1.66 μmol, 1.5 equiv.), 4.07 mM (1.10 μmol, 1.0 equiv.) or 2.03 mM (0.55 μmol, 0.5 equiv.) RNA solution in 10 mM sodium phosphate buffer (pH 6.8) was heated to 85 °C for 10 min and afterwards stored for 15 min at room temperature. 228 μL of a 4.8 mM solution of neomycin B sulfate (1.09 μmol) in 10 mM sodium phosphate buffer (pH 7.4) were added and the mixture was allowed to stand for 30 min at room temperature. Then 30 equiv. activated ester **3** (32.4 μmol) dissolved in 500 μL sodium phosphate buffer (pH 7.4) were added and the reaction mixture was allowed to react 24 hours at room temperature. After addition of 60 μL of a 7 wt. % ethylamine water solution and

further incubation for 30 min at room temperature the crude mixture was heated to 99 °C for 10 min. To the hot solution 1 mL of a 53 mM aqueous solution of diC₁₂DAB was added to precipitate the RNA. After incubation for 15 min at room temperature and centrifugation for 30 min at 6 °C (14k rpm) the supernatant was freeze dried. To obtain a sufficient amount of antibiotic derivative for NMR studies, this entire procedure was repeated twice and the resulting freeze dried samples were dissolved together in 400 µL water. Each 30 µL fraction was purified by HPLC using a Waters Spherisorb ODS-2C₁₈ analytic column (water/acetone 1:0.9 containing 12.1 mM HFBA) and a flow rate of 1 ml/min at 40 °C to determine the conversion of neomycin B to *mono*- and *di*-acetylated neomycin B derivatives and for investigation of the regioselectivity of the monoacetylation by NMR studies.

b) Procedure using 0.5 equiv. RNA and different reaction time.

A volume of 3.26 mL of a 6.1 mM (19.9 µmol, 1.5 equiv.) RNA solution in 10 mM sodium phosphate buffer (pH 6.8) was heated to 85 °C for 10 min and afterwards stored for 15 min at room temperature. Then 2.74 mL of a 4.8 mM solution of neomycin B sulfate (13.2 µmol) in 10 mM sodium phosphate buffer (pH 7.4) were added and the mixture was allowed to stand for 30 min at room temperature before 10 equiv. activated ester **3** (132 µmol) dissolved in 6.0 mL sodium phosphate buffer (pH 7.4) were added. After 1 min, 20 min, 2 h and 24 h an aliquot of 3 mL was taken out of the reaction mixture and incubated with 180 µL of a 7 wt. % ethylamine water solution for 30 min at room temperature. The purification, analysis and characterization was performed according to procedure (a).

c) Procedure using a 10, 30 and 60 mM sodium ion concentration.

A volume of 300 µL of a 5.54 mM (1.66 µmol, 1.5 equiv.) RNA solution in 10 mM sodium phosphate buffer (pH 6.8) was heated to 85 °C for 10 min and afterwards stored for 15 min at room temperature. Then a volume of 228 µL of a 4.8 mM solution of neomycin B sulfate (1.09 µmol) in 10 mM sodium phosphate buffer (pH 7.4) was added and the mixture was allowed to stand for 30 min at room temperature. Additionally, a volume of 50 µL of 10, 231 or 578 mM sodium chloride solution was added to reach a final salinity of 10, 30 or 60 mM Na⁺ concentration, respectively. To each reaction mixture 30 equiv. of NHS ester **3** (32.8 µmol) dissolved in 36 DMF were added. After a reaction time of 24 h at room temperature a volume of 60 µL of 7 wt. % ethylamine water solution was added and incubated for 30 min at room temperature. Finally, 100 µL of aq. 2 M NaOH solution were added and heated to 85 °C for 30 min and cooled down to room temperature. Each 50 µL

fraction was purified by HPLC using a Waters Spherisorb ODS-2C₁₈ analytic column (water/acetone 1.0:0.81 containing 16.9 mM HFBA) and a flow rate of 1 ml/min at 40 °C to determine the conversion of neomycin B to *mono*- and *di*-acetylated neomycin B derivatives and for investigation of the regioselectivity of the monoacetylation by NMR studies.

d) Procedure using different reaction temperature.

A volume of 300 μ L of a 6.1 mM (1.66 μ mol, 1.5 equiv.) RNA solution in 10 mM sodium phosphate buffer (pH 6.8) was heated to 85 °C for 10 min and afterwards stored for 15 min at room temperature. Then 228 μ L of a 4.8 mM solution of neomycin B sulfate (1.09 μ mol) in 10 mM sodium phosphate buffer (pH 7.4) were added and the mixture was allowed to stand for 30 min at room temperature before 30 equiv. activated ester **3** (32.8 μ mol) dissolved in 500 μ L sodium phosphate buffer (pH 7.4) were added. The reaction mixture was allowed to incubate for 24 h at 20, 40 or 50 °C and the antibiotic derivatives were purified according to procedure (b) using 93 μ L aq. 2M NaOH solution for the hydrolysis of RNA.

3.5.3 Characterization of Synthesized Neomycin B Derivative

6'''-N-acetyl neomycin B x 5 HFBA (4a). The title compound was prepared according to

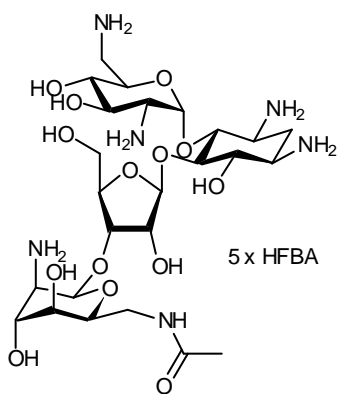

the general procedure described above using NHS ester **3**. Derivative **4a** was obtained as a white solid. For the measurement of regioselectivity and the characterization of the compound ¹H-NMR, HSQC as well as APT spectra were recorded and electrospray ionization (ESI)-MS was employed. The yield was calculated from ¹H-NMR- and HPLC peak integrals by: R_t = 7.5 min, 45 % yield (apt1). TLC (Chloroform/MeOH/17 % aq. NH₄OH 2:1:1 v/v/v) R_f = 0.52. ¹H-NMR (D₂O, 500 MHz) δ

(p.p.m.) 6.06 (d, J = 4 Hz, 1H, 1-H'), 5.44 (d, J = 2 Hz, 1H, 1-H''), 5.20 (d, J = 1.5 Hz, 1H, 1-H'''), 4.44 (t, J = 5.75 Hz, 1H, 3-H''), 4.39 (dd, J = 5 Hz, J = 2 Hz, 1H, 2-H''), 4.26 (t, J = 3 Hz, 1H, 3-H'''), 4.24 (m, 1H, 4-H''), 4.09 (t, J = 6.75 Hz, 1H, 5-H'''), 4.07 (m, 1H, 4-H), 4.01 (t, J = 10 Hz, 1H, 5-H'), 3.98 – 3.92 (m, 3H, 5-H_a'', 5-H, 3-H'), 3.76 (dd, 1H, J = 12.5 Hz, J = 5.5 Hz, 5-H_b''), 3.72- 3.68 (m, 2H, 4-H''', 6-H), 3.60 (dd, J = 14 Hz, J = 7.5 Hz, 1H, 6-H_a''), 3.56 (m, 2H, 3-H, 2-H'''), 3.53-3.41 (m, 4H, 6-H_a', 2-H', 6-H_b'', 4-H'), 3.38 (m, 1H, 1-H), 3.32 (dd, J = 14 Hz, J = 6 Hz, 1H, 6-H_b'), 2.51 (dt, J = 12.5 Hz; J = 3.8 Hz, 1H, 2-

H_{eq}), 2.04 (s, 3H, CH_3), 1.89 (dd, $J = 12.7$ Hz, 1H, $2-H_{ax}$). APT (D_2O , 125.7 MHz) δ (p.p.m.) 174.49 (Carbonyl-C), 110.00 (C-1''), 95.51 (C-1'''), 95.49 (C-1'), 84.62 (C-5), 81.66 (C-4''), 75.39 (C-3'''), 75.29 (C-4), 73.58 (C-2''), 72.45 (C-5'''), 72.42 (C-6), 70.35 (C-4'), 69.22 (C-3'), 67.88 (C-5'), 67.56 (C-3'''), 66.10 (C-4'''), 60.00 (C-5'), 53.15 (C-2'), 50.90 (C-2'''), 49.65 (C-1), 48.16 (C-3), 39.85 (C-6'), 39.33 (C-6'''), 27.88 (C-2), 21.74 (CH_3). MS (EI+) (m/z): found 657.33008 $[M+H]^+$, 679.31226 $[M+Na]^+$; calculated 657.33013 $[M+H]^+$, 679.31207 $[M+Na]^+$.

3.5.4 NMR-Spectra of Synthesized Neomycin B Derivatives

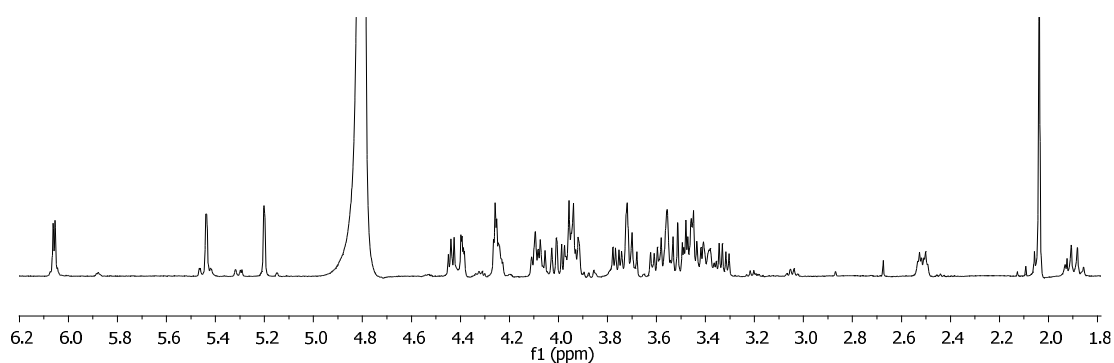

Figure 3.6a: 1H -NMR (500 MHz, D_2O) spectrum of 6'''-*N*-acetyl neomycin B x 5 HFBA **4a**.

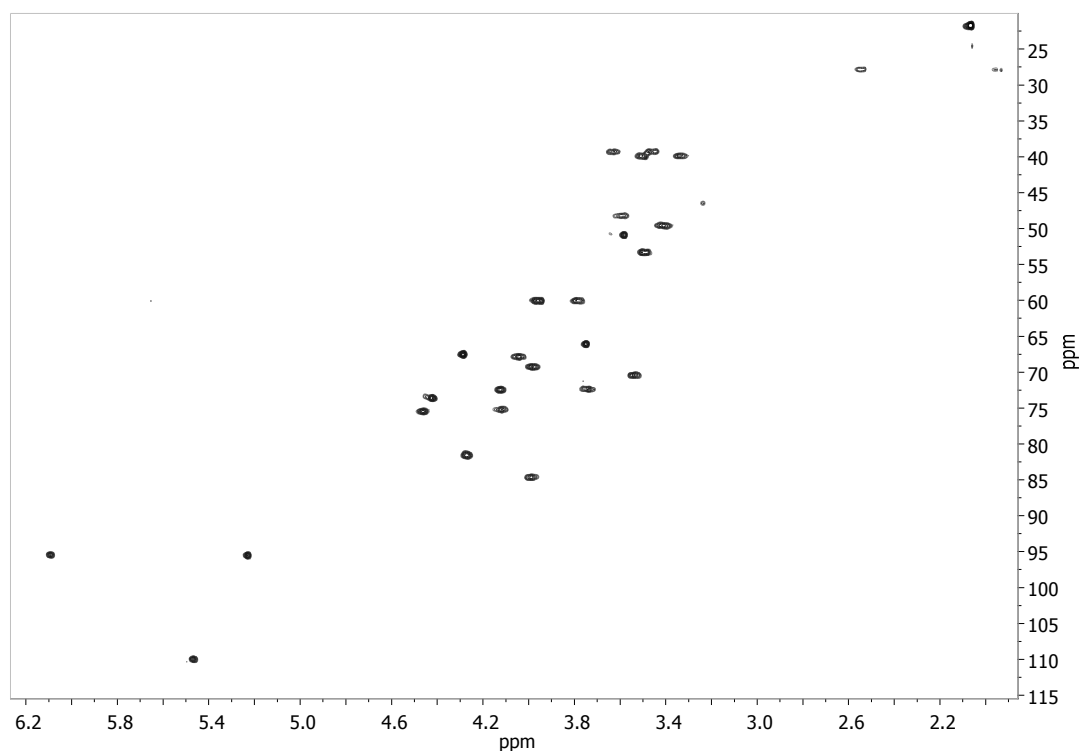

Figure 3.6b: HSQC (500 MHz, D_2O) spectrum of 6'''-*N*-acetyl neomycin B x 5 HFBA **4a**.

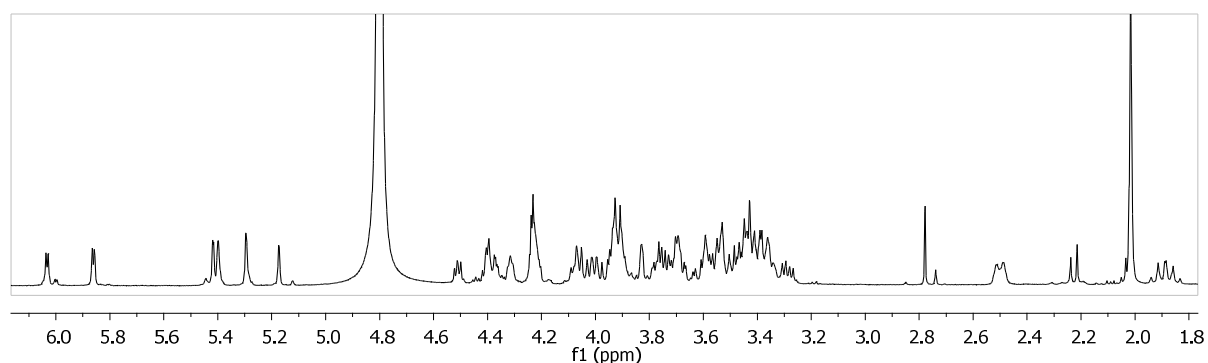

Figure 3.7a: $^1\text{H-NMR}$ (500 MHz, D_2O) spectrum of 1:1 mixture of acetyl neomycin B x 5 HFBA **4a** and **4b**. The mixture was synthesized applying the general procedure (3.5.2 a) but in absence of APG and using only 1 equiv. of activated ester **3**.

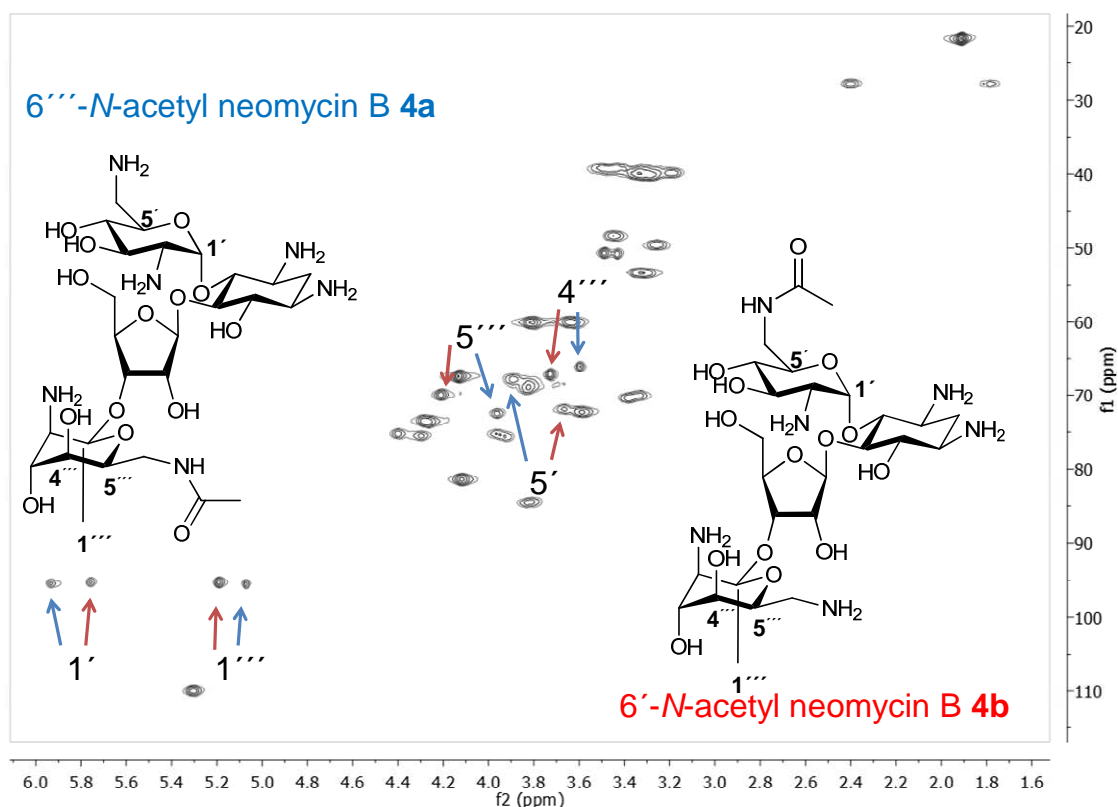

Figure 3.7b: HSQC (500 MHz, D_2O) spectrum of a 1:1 mixture of acetyl neomycin B x 5 HFBA **4a** and **4b**. The mixture was synthesized applying the general procedure (3.5.2 a) but without APG using only 1 equiv. of activated ester **3**.

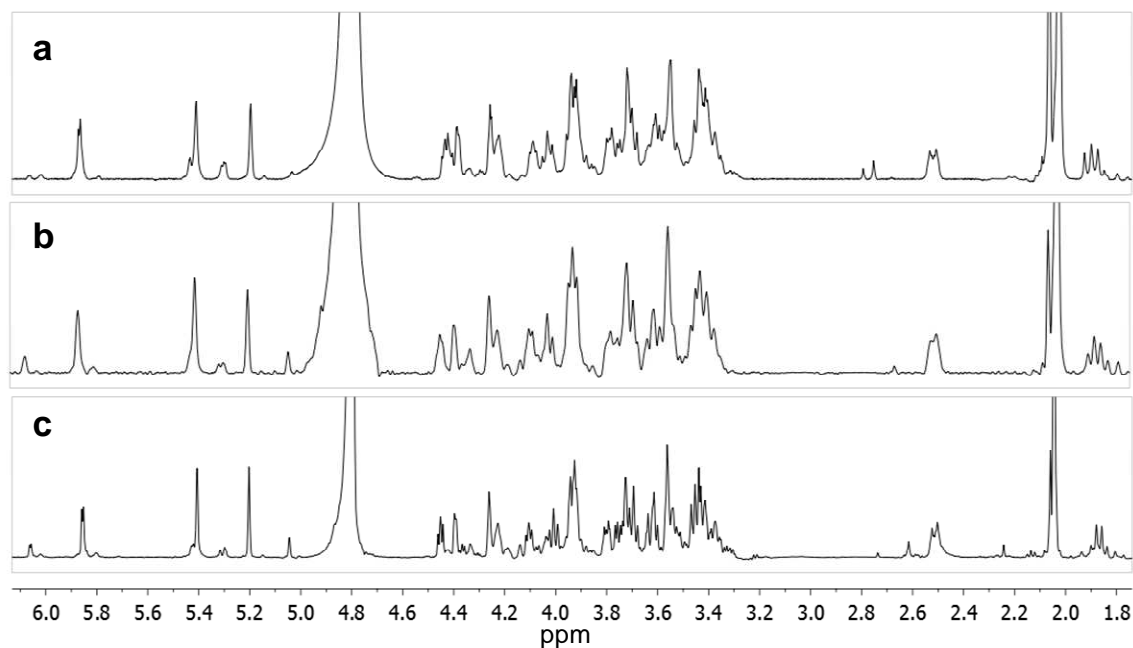

Figure 3.8: $^1\text{H-NMR}$ (500 MHz, D_2O) spectrum of 6',6'''-*N*-diacetyl neomycin B x 4 HFBA **5** synthesized without APG using 2 equiv. of activated ester **3** (a) and synthesized in presence of APGs **apt1** (b) and **apt2** (c) using 30 equiv. NHS ester **3**.

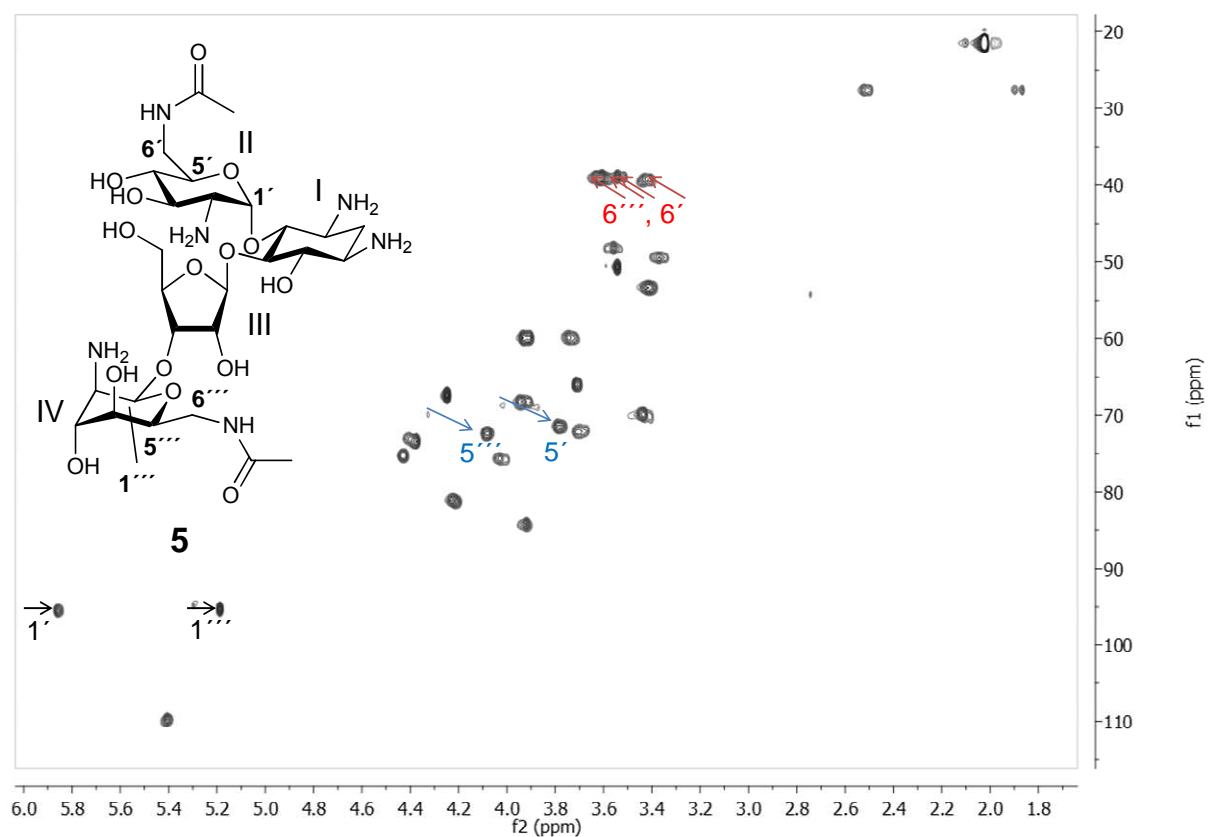

Figure 3.9: HSQC (500 MHz, D_2O) spectrum of 6',6'''-*N*-diacetyl neomycin B x 4 HFBA **5**. Arrows indicate the chemical shift of $J(\text{C}6\text{-H})$ - (red), $J(\text{C}5\text{-H})$ - (blue) and $J(\text{C}1\text{-H})$ coupling (black) of ring II and IV.

3.5.5 High Resolution Mass Spectrometric & High Performance Liquid Chromatography Analyses

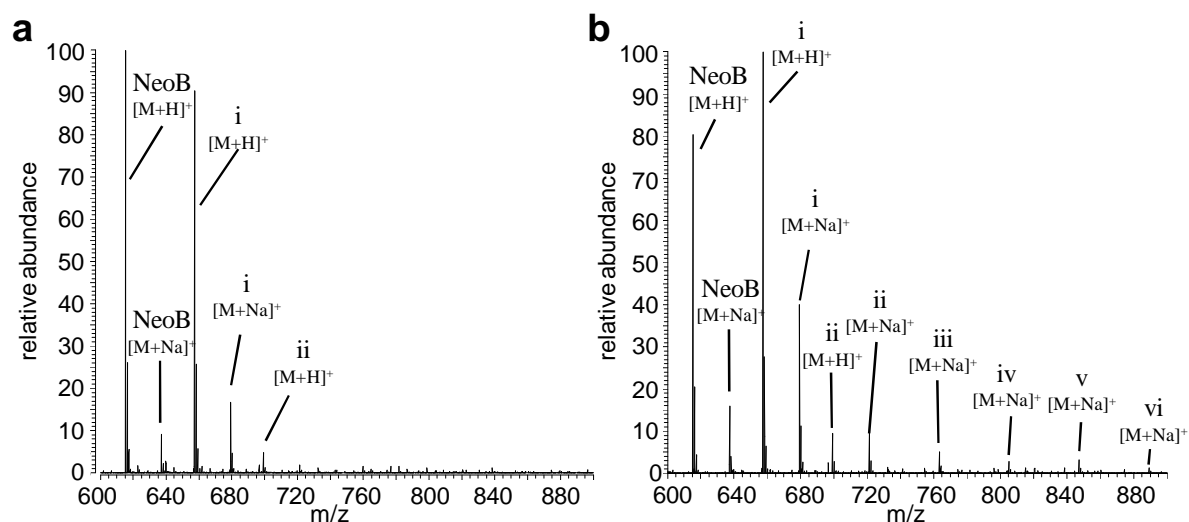

Figure 3.10: ESI-MS spectra of reaction mixture of neomycin B **1** (NeoB) reacted with 10 equiv. NHS ester **3** in presence of 1.5 equiv. APG **apt1** (a) and **apt2** (b) (i-vi = number of reacted amino groups of **1**).

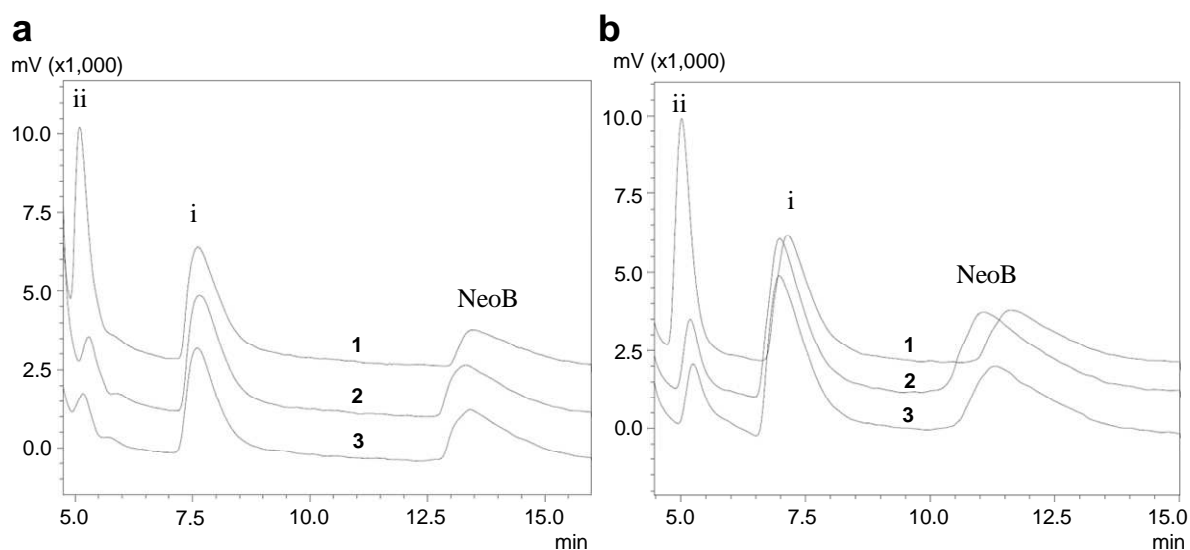

Figure 3.11: HPLC elugrams after transformation of neomycin B **1** (NeoB) with 30 equiv. of NHS ester **3** in presence of 0.5 equiv. (1), 1.0 equiv. (2) and 1.5 equiv. (3) APG **apt1** (a) and **apt2** (b) (i-ii = number of reacted amino groups of **1**).

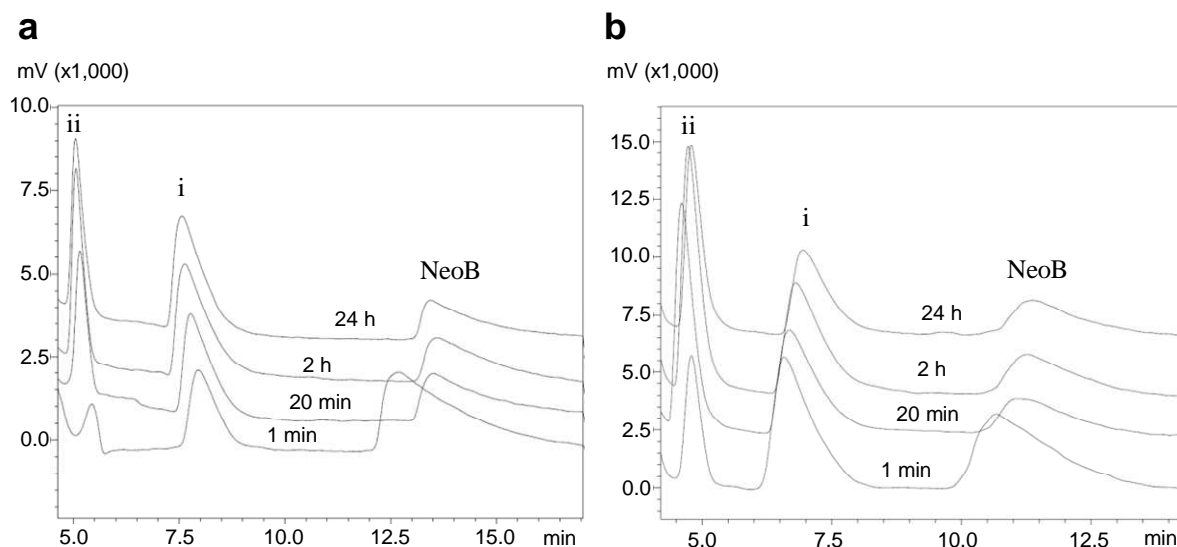

Figure 3.12: HPLC elugrams of neomycin B 1 (NeoB) reacted with 10 equiv. of NHS ester 3 in presence of 0.5 equiv APGs **apt1** (a) and **apt2** (b) applying different reaction times (i-ii = number of reacted amino groups of 1).

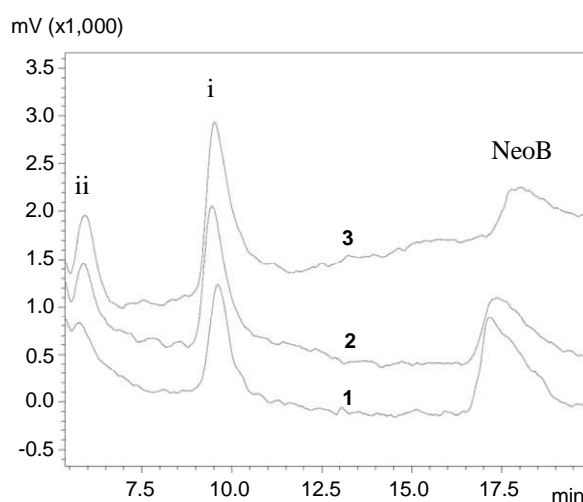

Figure 3.13: HPLC elugram of neomycin B 1 (NeoB) reacted with 30 equiv. of NHS ester 3 in presence of 1.5 equiv. APGs **apt1** at 20 °C (1), 40 °C (2) and 50 °C (3) (i-ii = number of reacted amino groups of 1).

3.5.6 Isothermal Titration Calorimetry

ITC was employed to determine the binding constants between neomycin B and the aptameric APG **apt1**, **apt2** and **apt3**. Microcalorimetric titrations of antibiotic **1** to RNA aptamers were performed by using a MicroCal ITC 200 Microcalorimeter (Northampton, MA). A 200 μ M neomycin B solution was injected from a 40 μ L rotating syringe into an isothermal sample chamber containing 200 μ L of 7 μ M aptamer solution. A 10 mM sodium phosphate buffer

(pH 6.8) was used to prepare both solutions, as well as to load the reference cell. The experiments were carried out at 25 °C and with a stirring speed of 1000 rpm. Typically, injections of 1.2 µL of titrant were added into the cell with a delay between injections of 100 seconds, up to a aptamer/antibiotic **1** ratio of 1:5. The effective heat of the antibiotic-aptamer interaction upon each titration step was corrected for dilution effect by subtracting the values obtained in the titration of **1** into buffer solution. Each injection generated a point for point heat curve (microcalories per second vs. time) which was conveniently integrated in order to obtain the heats of the bimolecular interactions associated with those injections. Then the normalized heat signals were analyzed by using the ITC non-linear curve fitting functions for two binding sites from *MicroCal Origin 7.0* software (*MicroCal*, Inc.; Northampton, MA). The satisfactorily fitted curve was used to determine the molar enthalpy change for binding (ΔH°) and the corresponding binding constant (K_a). Fundamental thermodynamic equations were used to determine the molar free energy of binding, ΔG° , and the molar entropy change (ΔS°). Each neomycin B-aptamer titration was repeated at least three times in order to increase the accuracy of the thermodynamic parameters.

Figure 3.14 (paragraph 3.2.1) on top shows the heats resulting from each injection of neomycin B into one of the aptamer solutions studied. On the bottom are the integrated heats after correcting for the heat of dilution, as well as, the best-fitted function. All the thermodynamic parameters were summarized in the Table 3.4. An inspection of the Figure 3.14 or the data in Table 3.4 reveals that each interaction between **1** with the APG (**apt1**, **apt2** and **apt3**) was enthalpy driven and resulted in exothermic reactions confirming that the specific RNA-aptamer interaction contributes strongly to the high complex stability. Although the three aptamers show the spontaneous formation of complexes, the natures of these were different. The titrations of **1** into **apt1** and **apt2** solutions showed similar profiles with two apparent phases, suggestive of two distinct binding sites (Fig.3.14a and Fig. 3.14b). In both aptamer-neomycin B complexes, the steepness of the first of the two phases resulted in association constants $K_{a,1}$ higher than 10^8 M^{-1} , indicating a tight binding interaction between **1** and the aptamers, **apt1** and **apt2**. In contrast, the titration of **1** into solution of **apt3** showed different profile. However, in agreement with the NMR results obtained in our studies applying all three aptamers, it is assumed that also **apt3** exhibits two different binding sites. In fact the profile can be fit to two-sites model with similar association constants (Fig. 3.14c). This model explains the creation of **4a** and **4b** at approximately equimolar ratio as main products from **apt3**, as compared with **apt1** and **apt2**. Thus, ITC results confirm the presence

of two binding sites of different affinity within **apt1** and **apt2**, and similar affinity within **apt3** for neomycin B.

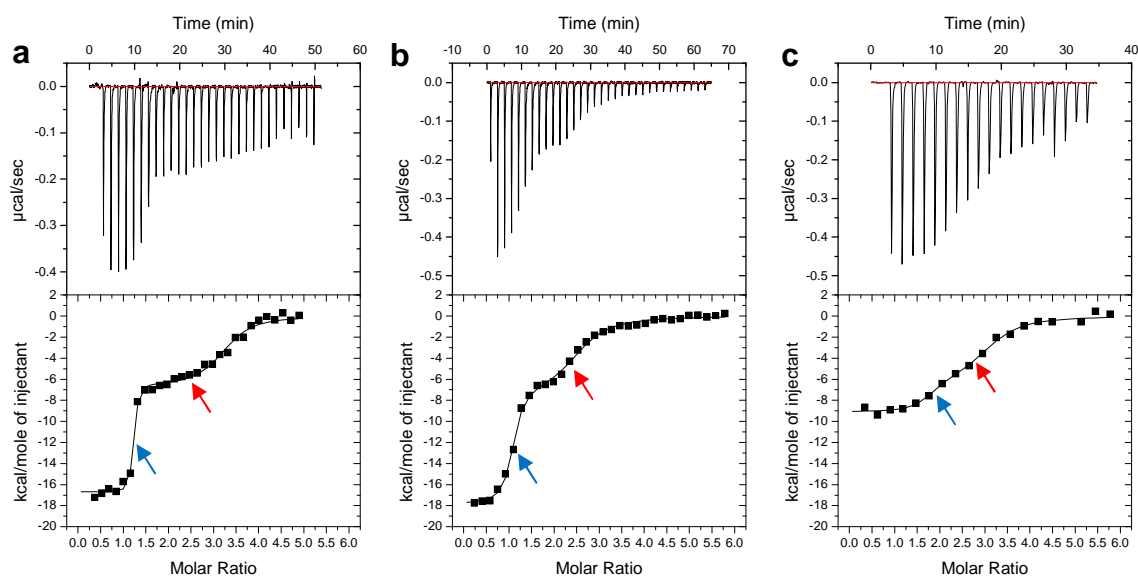

Figure 3.14: ITC profiles (top) and corresponding integrated injection heats (bottom) at 25.0 °C for the titration of 7 µM RNA aptamer solution (**apt1** (a), **apt2** (b) and **apt3** (c)) with 200 µM neomycin B solution (Neomycin B/RNA aptamer molar ratio). The integrated injection heats were corrected with the heat of dilution (derived from control titrations of aminoglycoside **1** into buffer alone), and then fitted by using a two binding site model (solid line). Applied buffer: 10 mM sodium phosphate, pH = 6.8. The blue arrows indicate the high affinity binding site and the red arrows the low affinity binding site.

Table 3.4: Association constants (K_a), molar entropy (ΔH°) and molar enthalpy (ΔS°) for complexation of neomycin B with RNA aptamers apt1, apt2 and apt3.

RNA	binding site	$K_a / 10^6 \text{ M}^{-1}$	$\Delta H^\circ / \text{kcal mol}^{-1}$	$\Delta S^\circ / \text{cal mol}^{-1} \text{ deg}^{-1}$
apt1	1	1542	- 14.9	- 7.9
	2	3.3	- 5.7	10.7
apt2	1	233	- 18.6	- 24.1
	2	1.9	- 7.2	4.6
apt3	1	62	- 9.1	5.1
	2	1.2	- 6.4	6.3

3.6 References

- 1 Cafeo, G., Kohnke, F. H. & Valenti, L. Regioselective O-alkylations and acylations of polyphenolic substrates using a calix[4]pyrrole derivative. *Tetrahedron Letters* **50**, 4138-4140 (2009).
- 2 Coqui re, D., de la Lande, A., Paris l, O., Prang , T. & Reinaud, O. Directional control and supramolecular protection allowing the chemo- and regioselective transformation of a triamine. *Chem.-Eur. J.* **15**, 11912-11917 (2009).
- 3 Sun, W., Du, L. P., Li, M. Y. Aptamer-based carbohydrate recognition. *Curr. Pharm. Design* **16**, 2269-2278 (2010).
- 4 Jiang, L. C. *et al.* Saccharide-RNA recognition in a complex formed between neomycin B and an RNA aptamer. *Struct. Fold. Des.* **7**, 817-827 (1999).
- 5 Jeong, S., Eom, T.-Y., Kim, S. J., Lee, S. W., Yu, J. *In vitro* selection of the RNA aptamer against the sialyl lewis X and its inhibition of the cell adhesion. *Biochem. Bioph. Res. Co.* **281**, 237-243 (2001).
- 6 Cho, J. Y., Hamasaki, K., Rando, R. R. The binding site of a specific aminoglycoside binding RNA molecule. *Biochemistry* **37**, 4985-4992 (1998).
- 7 Betat, H. *et al.* Aptamers that recognize the lipid moiety of the antibiotic moenomycin A. *Biol. Chem.* **384**, 1497-1500 (2003).
- 8 Wang, K. Y., McCurdy, S., Shea, R. G., Swaminathan, S., Bolton, P. H. A DNA aptamer which binds to and inhibits thrombin exhibits a new structural motif for DNA. *Biochemistry* **32**, 1899-1904 (1993).
- 9 Vianini, E., Palumbo, M., Barbara, G. *In vitro* selection of DNA aptamers that bind L-Tyrosinamide. *Bioorg. Med. Chem.* **9**, 2543-2548 (2001).
- 10 Tao, J. S., Frankel, A. D. Arginin-binding RNAs resembling Tar identified by *in vitro* selection. *Biochemistry* **35**, 2229-2238 (1996).
- 11 Famulok, M. & Szostak, J. W. Stereospecific recognition of tryptophan agarose by *in vitro* selected RNA. *J. Am. Chem. Soc.* **114**, 3990-3991 (1992).
- 12 Famulok, M. Molecular recognition of amino-acids by RNA-apatmers – an L-citrulline binding RNA motif and its evolution into an L-arginine binder. *J. Am. Chem. Soc.* **116**, 1698-1706 (1994).
- 13 Kato, T., Yano, K., Ikebukuro, K., Karube, I. Interaction of three-way DNA junctions with steroids. *Nucleic Acids Res.* **28**, 1963-1968 (2000).
- 14 Mannironi, C., DiNardo, A., Fruscoloni, P., Tocchini Valentini, G. P. *In vitro* selection of dopamine RNA ligands. *Biochemistry* **36**, 9726-9734 (1997).
- 15 Baugh, C., Grate, D., Wilson, C. 2.8   crystal structure of the malachite green aptamer. *J. Mol. Biol.* **301**, 117-128 (2000).
- 16 Iliuk, A. B., Hu, L. H., Tao, W. A. Aptamer in bioanalytical applications. *Anal. Chem.* **83**, 4440-4452 (2011).
- 17 Tuschl, T., Borkhardt, A. Small interfering RNAs: A revolutionary tool for the analysis of gene function and gene therapy. *Molecular interventions* **2**, 158-167 (2002).
- 18 Xia, H. B., Mao, Q. W., Paulson, H. L., Davidson, B. L. siRNA-mediated gene silencing *in vitro* and *in vivo*. *Nat. Biotechnol.* **20**, 1006-1010 (2002).

Chapter 3

- 19 Burnett, J. C., Rossi, John, J. RNA-based therapeutics: Current progress and future prospects. *Biochemistry and Biology* **19**, 60-71 (2012)
- 20 Stampfl, S., Lempradl, A., Koehler, G. & Schroeder, R. Monovalent ion dependence of neomycin B binding to an RNA aptamer characterized by spectroscopic methods. *Chem. Bio. Chem.* **8**, 1137-1145 (2007).
- 21 Cowan, J. A., Ohyama, T., Wang, D. Q. & Natarajan, K. Recognition of a cognate RNA aptamer by neomycin B: Quantitative evaluation of hydrogen bonding and electrostatic interactions. *Nucleic. Acids. Res.* **28**, 2935-2942 (2000).
- 22 Kaul, M., Pilch, D. S. Thermodynamics of aminoglycoside-rRNA recognition: The binding of neomycin-class aminoglycosides to the A site of 16S rRNA. *Biochemistry* **41**, 7695-7706 (2002).
- 23 Wallis, M. G., Vonahsen, U., Schroeder, R. & Famulok, M. A novel RNA motif for neomycin recognition. *Chem. Biol.* **2**, 543-552 (1995).
- 24 Jacobson, K. A., Kirk, K. L., Padgett, W. L., Daly, J. W. Functionalized congeners of adenosine: Preparation of analogs with high affinity for A1-adenosine receptors. *J. Med. Chem.* **28**, 1341-1346 (1985).

Chapter 4

Aptameric Protective Groups Enable Various Transformations in Different Positions of Neamine Antibiotics

(Part of this chapter is published online:

A. A. Bastian, A. Marcozzi, A. Herrmann. *Nature Chemistry* **4**, 1-5 (2012))

(Based on this chapter a European patent is filed: A. Bastian, A. Marcozzi, A. Herrmann 2011)

In the first chapter, RNA sequences have been introduced as efficient non-covalent protective groups for the regioselective modification of structurally complex natural products. Their application as aptameric protective groups (APGs) allowed the transformation of a single functional group out of several present in neamine antibiotics, namely neomycin B and paromomycin, with high regioselectivities. So far, modifications were introduced successfully using *N*-hydroxysuccinimide esters as acyl-transfer reagent resulting in novel antibiotic derivatives. Here, we demonstrate that APGs allow the application of different reactions and conditions for regioselective modifications of neamine antibiotics. Furthermore, we prove that the application of same RNA sequences as APG enables the synthesis of a broad spectrum of aminoglycosides derivatives modified at different positions with excellent regioselectivities of >99 %. The introduction of new functional groups in neamine antibiotics will accelerate the synthesis of new promising antibiotic derivatives. Moreover, this work emphasized the applicability of oligonucleotides as APGs allowing facile access to novel derivatives of structurally complex natural products.

4.1 Introduction

The application of non-covalent protective groups based on host-guest interactions has recently emerged as a promising and simpler alternative to standard covalent protection and deprotection protocols in derivatization of multifunctionalized compounds.^{1,2} *Reinaud et al.* applied a zinc(II)-complex based on a functionalized calix[6]arene as supramolecular protective group (SPG) for the chemo- and regioselective carbamoylation of the unsymmetrical triamine *N*-(2-aminoethyl)propane-1,3-diamine.¹ Similarly, *Kohnke et al.* utilized a calix[4]pyrrole derivative as SPG in the selective O-alkylation of 6-hydroxy-1-naphthol.² However, these host systems exhibit serious limitations as non-covalent protective groups. Due to the small cavity size their application as SPG is limited to small guest molecules. Moreover, the generalization of the concept on the basis of macrocyclic cavities is prohibitively difficult due to the painstaking design and synthesis of the host system required for the guest molecule.

To overcome these limitations, ribonucleic acids were introduced as aptameric protective groups (APGs) for the regioselective derivatization of more complex structures (chapter 2). It is well known that strong binders consisting of RNA and DNA aptamers can be evolved through the straightforward Systematic Evolution of Ligands by EXponential Enrichment (SELEX) process.^{3,4} The resulting sequences can be produced by automated synthesis in large scale and they can act as ligands for a wide variety of low molecular weight compounds^{5,6,7,8,9} as well as biomacromolecules, especially proteins.^{10,11,12}

Facing these advantages, the applicability of APGs for the regioselective modification of neamine antibiotics neomycin B **1** and paromomycin **2** (Fig. 4.1a) were investigated. It was demonstrated that the APG **apt1** protects non-covalently ring I, II and III of antibiotic **1**, while ring IV is available for chemical transformation (Fig. 4.1b). Moreover, in our previous study two more aptameric sequences, i.e. **apt2** and **apt3** (Fig. 4.1c), that were chosen randomly from a pool of published RNA sequences,¹³ were applied successfully as APGs (chapter 2). Furthermore, it was demonstrated that the utilization of these aptamers as non-covalent protective group for antibiotic **1** and **2** enabled regioselective acylation of the amino group in C6 position at ring IV of antibiotics **1** and **2**.

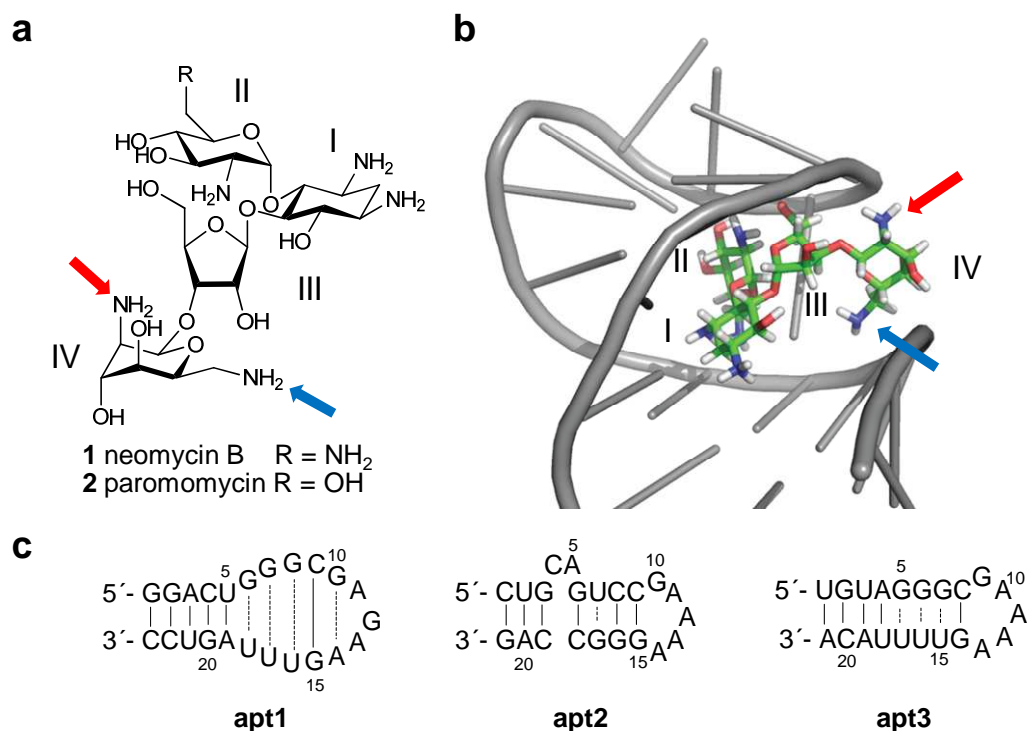
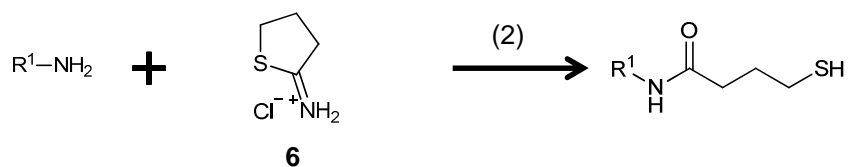
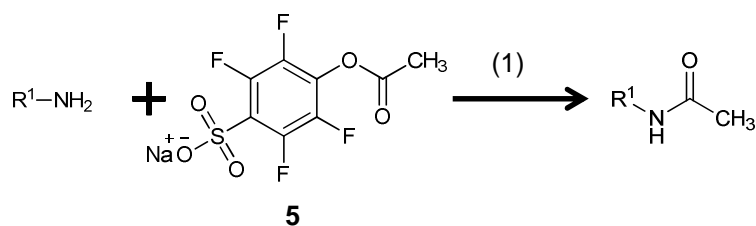
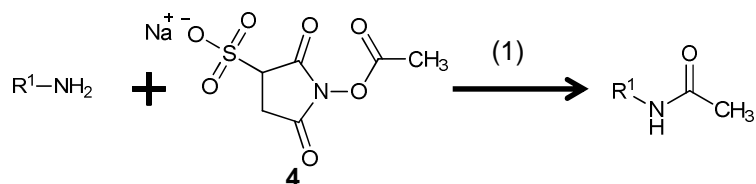
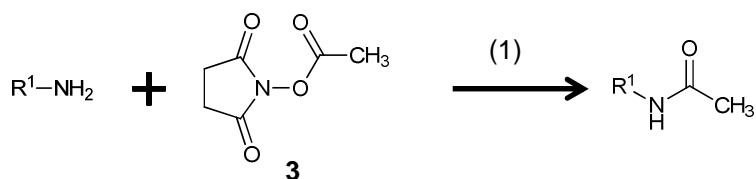

Figure 4.1: **a**, Aminoglycoside antibiotics used for regioselective modification protected by APGs. **b**, Neomycin B **1** – **apt1** complex;¹⁴ color code: white – hydrogen, green – carbon, blue – nitrogen, red – oxygen, grey – APG **apt1**. Arrows indicate the amino groups in C2 position (red) and C6 position (blue) at ring IV of antibiotic **1**. **c**, RNA sequences applied as APGs for neamine antibiotics **1** and **2**.

However, the APG strategy is limited so far to one chemical transformation. Neomycin B and paromomycin were so far only acylated using *N*-hydroxysuccinimide (NHS) esters as shown in Scheme 4.1 for acetyl-NHS ester **3**. Furthermore, the modification of neamine antibiotics **1** and **2** is restricted to the transformation of the amino group in C6 position at ring IV applying APGs (blue arrow in Fig. 4.1a and b). To establish the APG technology as a general tool in organic synthesis its scope needs to be extended. For that reason, in this chapter we demonstrate that APGs enable also modifications in another position than the 6C position of antibiotic's ring IV (red arrow in Fig. 4.1a and b). In particular, we applied successfully diverse reagents enabling modifications, namely acylation, azide introduction and urea derivative formation, at the C6 and C2 position at ring IV of aminoglycosides **1** and **2** (Scheme 4.1).

Chapter 4

transformation of amine in C-6 position:



transformation of amine in C-2 position :

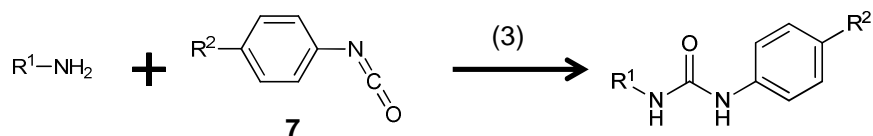

transformation of amine in C-2 and C-6 position:

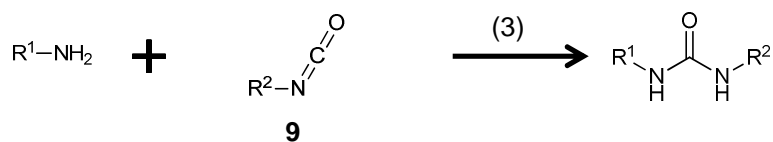
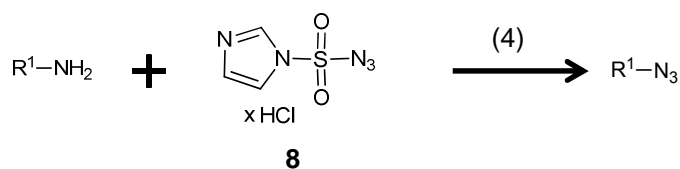

Scheme 4.1: Reactions for the regioselective transformations of amino groups at the neamine antibiotic's ring IV in presence of APGs: acylation (1), thiolation (2), urea bond formation (3) and azide introduction (4).

4.2 Results & Discussion

4.2.1 Regioselective Modification of Antibiotic's Ring IV in C6 Position

4.2.1.1 Modification Using Negatively Charged Activated Ester

Since the transformation of the neamine antibiotics **1** and **2** protected by APG takes place in an aqueous buffer solution, the introduction of hydrophobic residues via acylation reaction is limited by the low solubility of NHS-esters in water. Therefore, negatively charged activated esters, sulfo-*N*-hydroxysuccinimide (sulfo-NHS) ester **4** and 4-sulfo-*tetra*-fluorophenyl (STP) ester **5**, were employed as acyl-transfer reagents in this study (Fig. 4.2). Due to their negative charge at the sulfo group these activated ester show higher solubility in aqueous solution and therefore, they have been already applied successfully as acyl-transfer reagents under such conditions.^{15,16}

To test the applicability of negatively charged activated NHS ester **4** for modification of the amino group in C6 position at ring IV of antibiotic **1** we used the 23mer RNA aptamer **apt1** as APG. The **apt1**-aminoglycoside **1** complex was reacted with 10 equivalents of sulfo-NHS ester **4** (Fig. 4.2a). To determine the reactivity of ester **4** with neomycin B protected by **apt1** High Performance Liquid Chromatography (HPLC) analysis was performed. As shown in Figure 4.2b, after a reaction time of 24 hours a conversion of 7 % of **1** to *mono*-acetylated neomycin B derivatives was determined. In contrast, using a non-charged NHS ester a conversion of the neomycin B up to 71 % was detected (chapter 2). The low reactivity can be explained by repulsion of negative charges located at the APG and reagent **4**. Since the RNA sequence **apt1** exhibits a negatively charged phosphate backbone, we assume that the attack of ester **4** at ring IV of neomycin B is hindered by the APG.

However, to test whether a different negative charged acetyl-transfer reagent can be applied for the transformation, we utilized acyl-transfer reagent **5** which also carries a sulfo group (Fig 4.2a). In contrast to the NHS ester **4**, STP ester **5** was reactive under same conditions. As shown in Figure 4.2c, neomycin B was converted mainly to *mono*-acetylated products with conversions of 31 % and a yield of approx. 30 %, while *di*-acetylated derivatives were formed reaching a conversion of only 4 %. Performing the reaction at higher temperature (40 °C) to increase the conversion gave the same result.

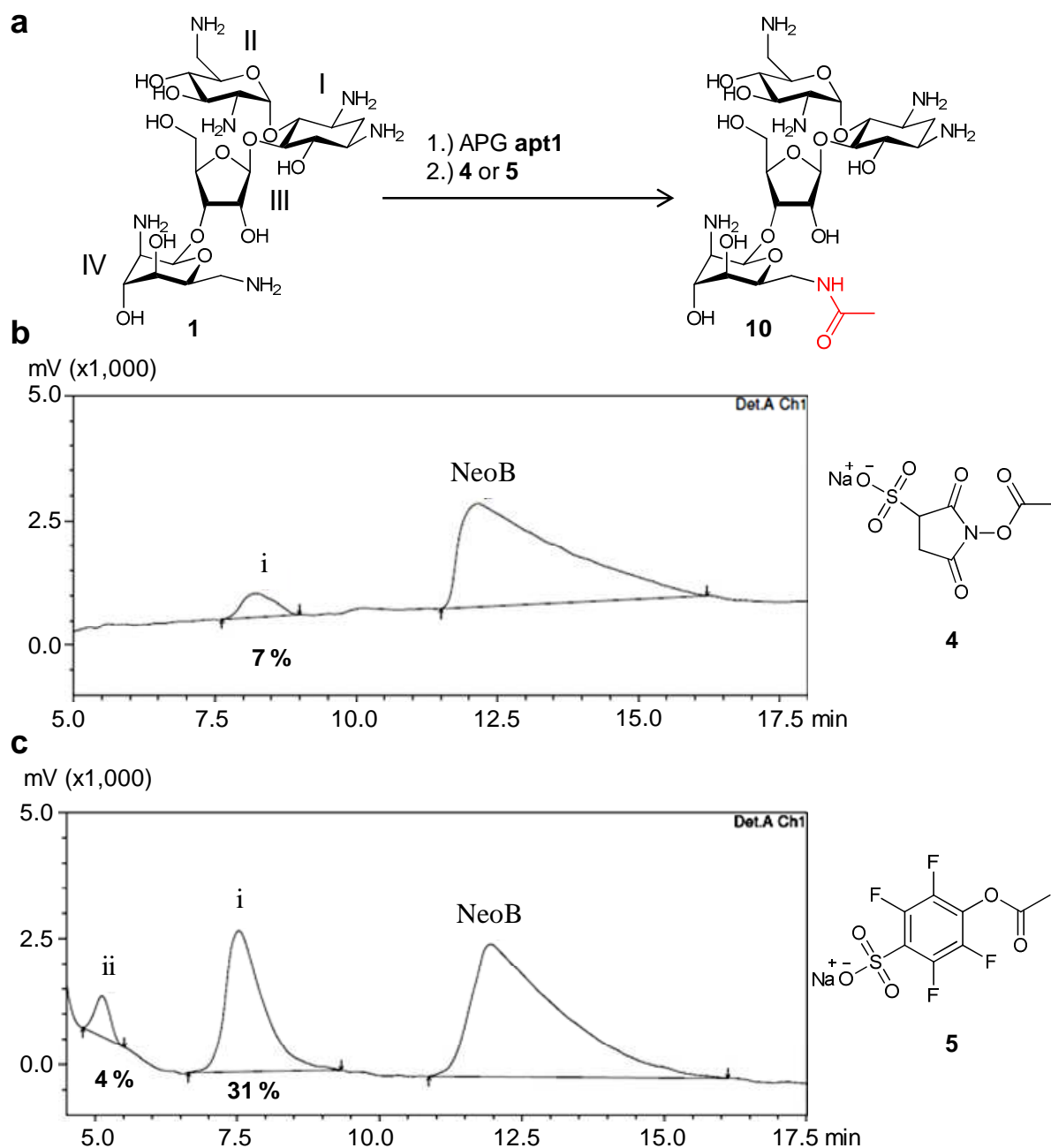

Figure 4.2: **a**, Regioselective transformation of antibiotic **1** (NeoB) using 15 equiv. of activated esters **4** and **5** in presence of 1.5 equiv. of **apt1**. Reactions were performed in 10 mM sodium phosphate buffer (pH \approx 7) at room temperature and 24 hours reaction time. **b**, HPLC elugram of reaction mixture after transformation of **1** employing sulfo-NHS ester **4**. **c**, HPLC elugram of reaction mixture after transformation of **1** using STP-ester **5** (i-ii = number of reacted amino groups of **1**). Conversions of **1** to *mono*- and *di*-substituted derivatives are given below the corresponding peaks. It is assumed that only *mono*- and *di*-acetylated derivatives were formed.

However, SPT ester **5** showed increased reactivity compared to activated ester **4**. This behavior can be explained by their different molecular structures. As shown in Figure 4.3,

computer models of both compounds suggest that the sulfo-NHS ester **4** exhibits a sterically more demanding structure due to the presence of sp^3 -hybridized carbon atoms. In comparison, activated ester **5** has predominantly sp^2 -hybridized carbon atoms resulting in a planar structure. Due to the fact that the sulfo group is located in the *para*-position to the ester group, we assume that the flat structure of the aromatic STP ester **5** enables a reaction with the protected antibiotic **1** despite the negative charge. Another possible explanation for the higher reactivity of **5** is the occurrence of π - π -interactions of **5** with the aromatic nucleobases of the APG compensating the electrostatic repulsion.

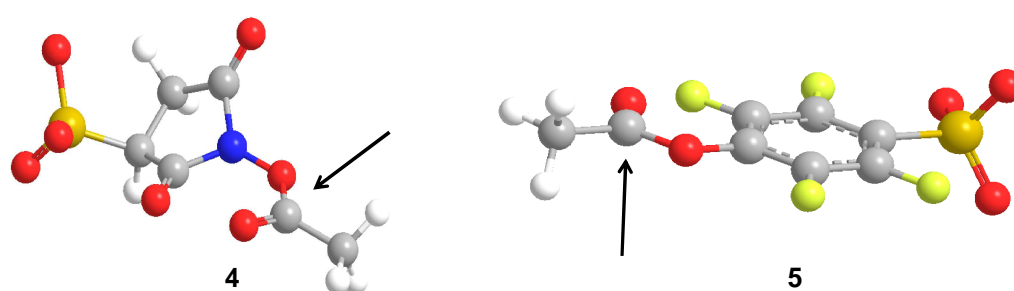
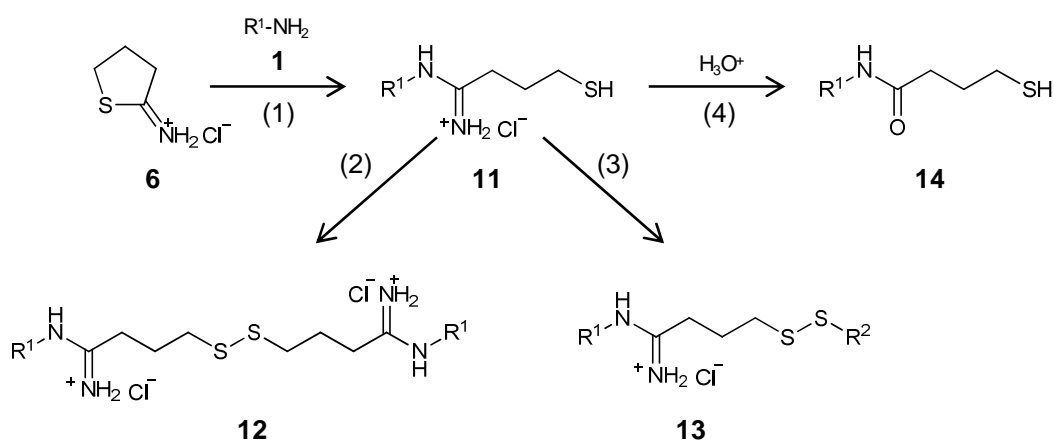

Figure 4.3: Simulated 3D-structures (*ChemDraw*) of activated esters **4** and **5**. Color code: white – hydrogen, grey – carbon, blue – nitrogen, red – oxygen, orange – sulfur, yellow – fluorine. The black arrows indicate the electrophiles for a nucleophilic attack.

To determine the regioselectivity of the transformation using STP-ester **5**, the fraction of *mono*-acetylated neomycin B derivatives was purified and $^1\text{H-NMR}$ - and HSQC spectra were recorded (see experimental part Fig. 4.11a and 4.11b). This analysis showed that **1** was acetylated at the amino group in C6 position of ring IV resulting in antibiotic derivative **10** with a regioselectivity of 83 %. However, the regioselectivity is considerable lower in comparison to the utilization of acetyl NHS-ester **3**, which reached a selectivity of 95 % (chapter 2). This difference can be explained by the increased salt concentration in the reaction mixture. Due to the fact that the activated ester **5** is applied as sodium salt, a final salt concentration of approx. 26 mM is reached in the reaction mixture. In chapter 3.2.4 it was demonstrated that the regioselectivity of the acetylation reaction is decreasing with higher salinity due to the destabilization of the **apt1**-aminoglycoside **1** complex.¹⁷ Therefore, with the increase of sodium concentration the amine group in C6 position of ring II of neomycin B becomes also available for transformations resulting in lower regioselectivities for the acylation reaction.

4.2.1.2 Introduction of a Sulfhydryl Group Using *Traut's* Reagent

After we demonstrated that the negatively charged reagent, STP-ester **5**, can be applied in the regioselective transformation of neomycin B, we investigated whether an APG also allows the application of positively charged reagents. As a straightforward proof we applied 2-iminothiolane hydrochloride **6** (Scheme 4.2) as an acyl-transfer reagent. Named after its inventor *Traut's*, reagent **6** is fully water soluble, stable and reacts preferably with primary amino groups.¹⁸ Moreover, after transformation with **6**, a sulfhydryl group is available for further coupling reactions (Scheme 4.2). Due to the scope of further derivatization this cyclic imidothioester **6** has been successfully applied for thiolation of biomacromolecules such as proteins and enzymes^{19,29} and oligosaccharides.^{21,22} As shown in Scheme 4.2, in an additional synthetic step the thiolated product **11** can undergo an oxidative dimerization resulting in product **12** or be coupled in the same manner to different thiolated substrates giving asymmetric products **13**.



Scheme 4.2: Possible scenario for the downstream reactions after thiolation of an amino group of antibiotic **1** with *Traut's* reagent: Thiolation of an amine with 2-iminothiolane **6** (1), oxidative dimerization (2), conjugation of iminium chloride **11** (3) and acidic hydrolysis of **11** to acylated product **14** (4).

However, the formed iminium ion **11** is not stable against hydrolysis under acidic conditions ($pH < 3$) (Scheme 4.2).²³ Due to the fact that the synthesized antibiotic derivatives were purified by HPLC using an acidic eluent ($pH 2$), the hydrolyzed product **14** was obtained. Nevertheless, applying excess of *Traut's* reagent **6** and **apt1** as APG neomycin B was modified regioselectively in C6 position at ring IV resulting in thiolated derivative **14** (Fig. 4.4a). This was proven employing 2D-NMR spectroscopic measurements as demonstrated in Figure 4.4b.

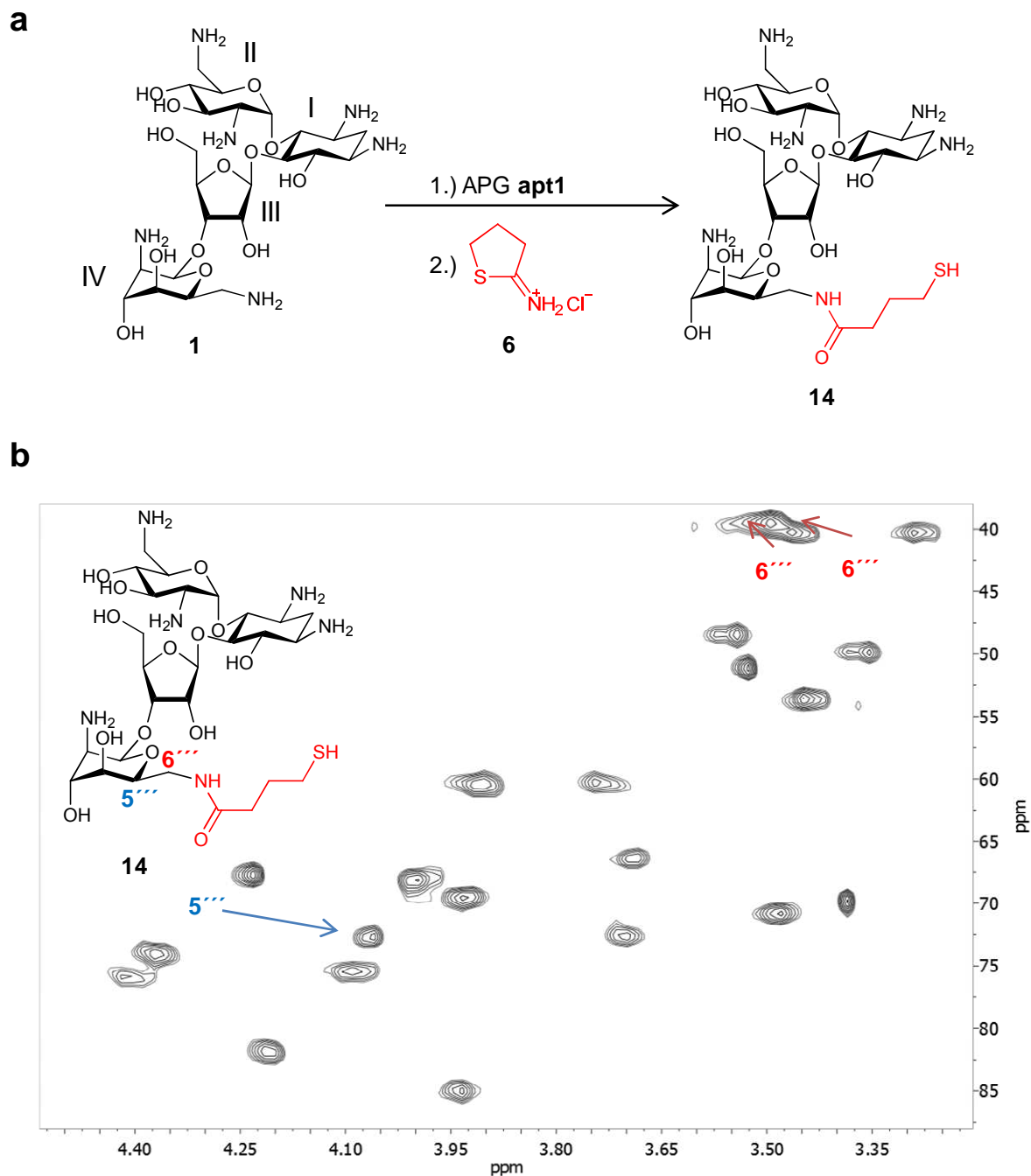

Figure 4.4: **a**, Regioselective thiolation of neomycin B in presence of 1.5 equiv. APG **apt1** using *Traut's* reagent **6**. Reaction was performed in 10 mM sodium phosphate buffer (pH \approx 7) at room temperature and 24 hours reaction time. **b**, HSQC-section of antibiotic derivative **14**. Chemical shifts of the $J(\text{C6}'''\text{-H})$ couplings (red arrows) and the $J(\text{C5}'''\text{-H})$ coupling (blue arrow) indicate regioselective acylation of the amino group in C6 position at ring IV.

Furthermore, using an excess of 30 equivalents of reagent **6** resulted in a regioselectivity of only 74 % in order to form thiolated derivative **14** as calculated from $^1\text{H-NMR}$ data (Table 4.1, see experimental part Fig. 4.12a). However, using 30 equivalents of *Traut's* reagent the

mono-thiolated derivatives were obtained with a yield of 57 %, while the utilization of reduced amounts of **6** gave lower yields reaching 43 % and 40 % using 15 and 5 equivalents, respectively (Table 4.1). As demonstrated by HPLC analysis, in all cases neomycin B was mainly converted to mono-acylated derivatives using *Traut's* reagent (see experimental part Fig. 4.23). In contrast to the decreasing yields, the regioselectivity of the acylation reaction increased up to 91 % using reduced amounts of **6** (Table 4.1).

Table 4.1: Yields and regioselectivities of the transformation of neomycin B using different amounts of *Traut's* reagent (6**).**

Compound	equiv. of 6	yield [^] (%)	r.s. [*] (%)
14	30	57	74
14	15	43	89
14	5	40	91

All reactions were carried out according to the general procedure (see experimental part 4.4.2.3.1).

[^] Isolated yields of *mono*-thiolated derivative **14** (isomer mixture). Yields were determined by HPLC.

^{*} Regioselectivities (r.s.) were calculated using ¹H-NMR spectroscopy.

The low regioselectivity and enhanced formation of more side products using 30 equivalents of **6** can be explained by destabilization of the **apt1**-aminoglycoside **1** complex by the excess of the charged reagent **6**. As demonstrated in previous studies, the complex stability is mainly determined by the charge-charge interactions of neomycin B and the aptamer **apt1**.¹⁷ Furthermore, it was shown that the complex stability was reduced with the increase of positively charged counter ions (chapter 3). Therefore, we assume that the positively charged iminium group of the *Traut's* reagent **6** weakens the **apt1**-antibiotic **1** interaction leading to side reactions. Therefore, optimization of stoichiometric ratio of reagent **6** and APG protected neomycin B was necessary to reduce the formation of side products and obtain high regioselectivity (91 %).

This result demonstrates that the APG methodology allows not only the application of neutral NHS esters and negatively charged STP esters, but also the utilization of the positively charged acyl-transfer reagent 2-iminothiolane hydrochloride **6**. A further advantage of the

presented thiolation strategy is that neomycin B can be conjugated to other entities in only one additional synthetic step without the use of APGs. This gives a facile access to a broad range of antibiotic derivatives modified at ring IV.

4.2.2 Regioselective Modification of Antibiotic's Ring IV in C2 Position Employing Urea Bond Formation.

So far, we successfully demonstrated that the APG-strategy facilitates regioselective transformation of two neamine antibiotics, namely neomycin B **1** and paromomycin **2**, using various types of acylation reagents. For this approach three different aptameric sequences were successfully utilized as APGs (chapter 2). However, these aptamers enabled so far the modification of the amino group in C6 position at ring IV of these aminoglycosides. In contrast, here we present the application of the same APGs enabling chemoselective transformations of the amino group in C2 position at ring IV reaching high regioselectivities. For this approach urea bond formation was applied for transformation of antibiotics **1** and **2** using **apt1** and **apt2** as APGs.

For the straightforward proof of the chemo- and regioselective transformation, neomycin B was reacted with 15 equivalents of p-methoxyphenyl isocyanate **7a** in absence and presence of **apt1** and the reaction mixtures were analyzed using **High Resolution Mass Spectrometry (HRMS)** and HPLC. As demonstrated by mass spectrometric and HPLC analyses, in absence of **apt1** antibiotic **1** was transformed to an inseparable mixture of derivatives exhibiting up to four urea groups (Fig. 4.5a and Fig. 4.5c), whereas in presence of **apt1** only one amino group was transformed (Fig. 4.5b and 4.5d). Also the application of APG **apt2** resulted only in the formation of a single urea derivative as demonstrated by HPLC analysis (see experimental part Fig. 4.24).

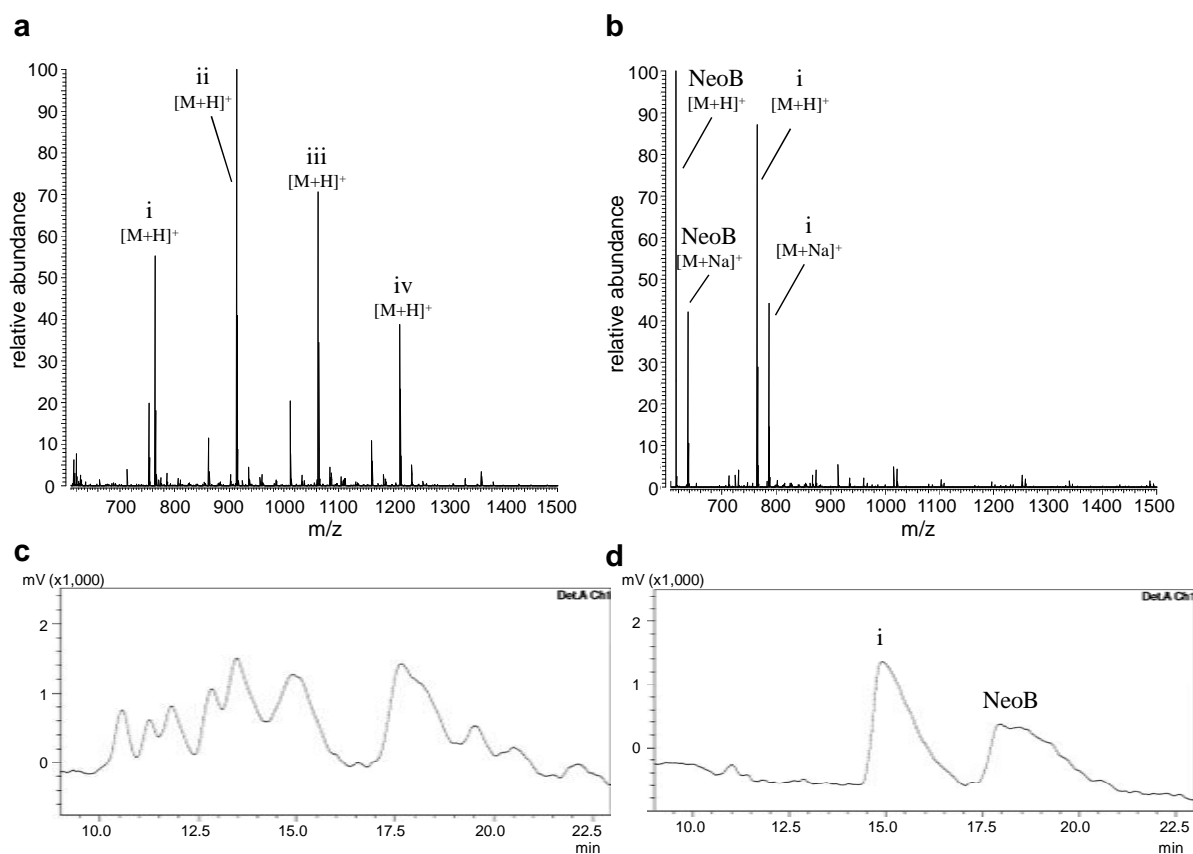

Figure 4.5: HRMS spectra of reaction mixture after transformation of neomycin B **1** using 15 equivalents of p-methoxyphenyl isocyanate **7a** in absence (a) and presence (b) of 1.5 equivalent APG **apt1**. HPLC elugram of reaction mixture after transformation of **1** in absence (c) and presence (d) of **apt1**. (i-iv = number of reacted amino groups of **1**).

Further characterization of the *mono*-urea derivative by NMR experiments proved that antibiotic **1** was transformed exclusively at a single position in presence of APGs resulting in aminoglycoside derivative **15a** (Fig. 4.6a, Table 4.2). As demonstrated in Figure 4.6b, the HSQC spectrum proves the regioselective transformation of the amino group in C2 position at ring IV resulting in antibiotic derivative **15a**. Moreover, $^1\text{H-NMR}$ spectroscopic measurements (see experimental part Fig. 4.13a) showed exclusively the presence of regioisomer **15a**, when employing **apt1** and **apt2** as APG (Table 4.2). Furthermore, similar results were achieved using isocyanates **7b** and **7c** as reagents (Fig. 4.6a). As shown in Table 4.2, the transformation of antibiotic **1** using **7b** resulted also exclusively in regioisomer **15b**, while the utilization of isocyanate **7c** yielded derivative **15c** with slightly lower regioselectivity. Furthermore, all reactions show moderate conversions (Table 4.2) of neomycin B and resulting the *mono*-urea derivatives were isolated by HPLC reaching yields of up to 51 % using urea bond formation (Fig. 4.6a).

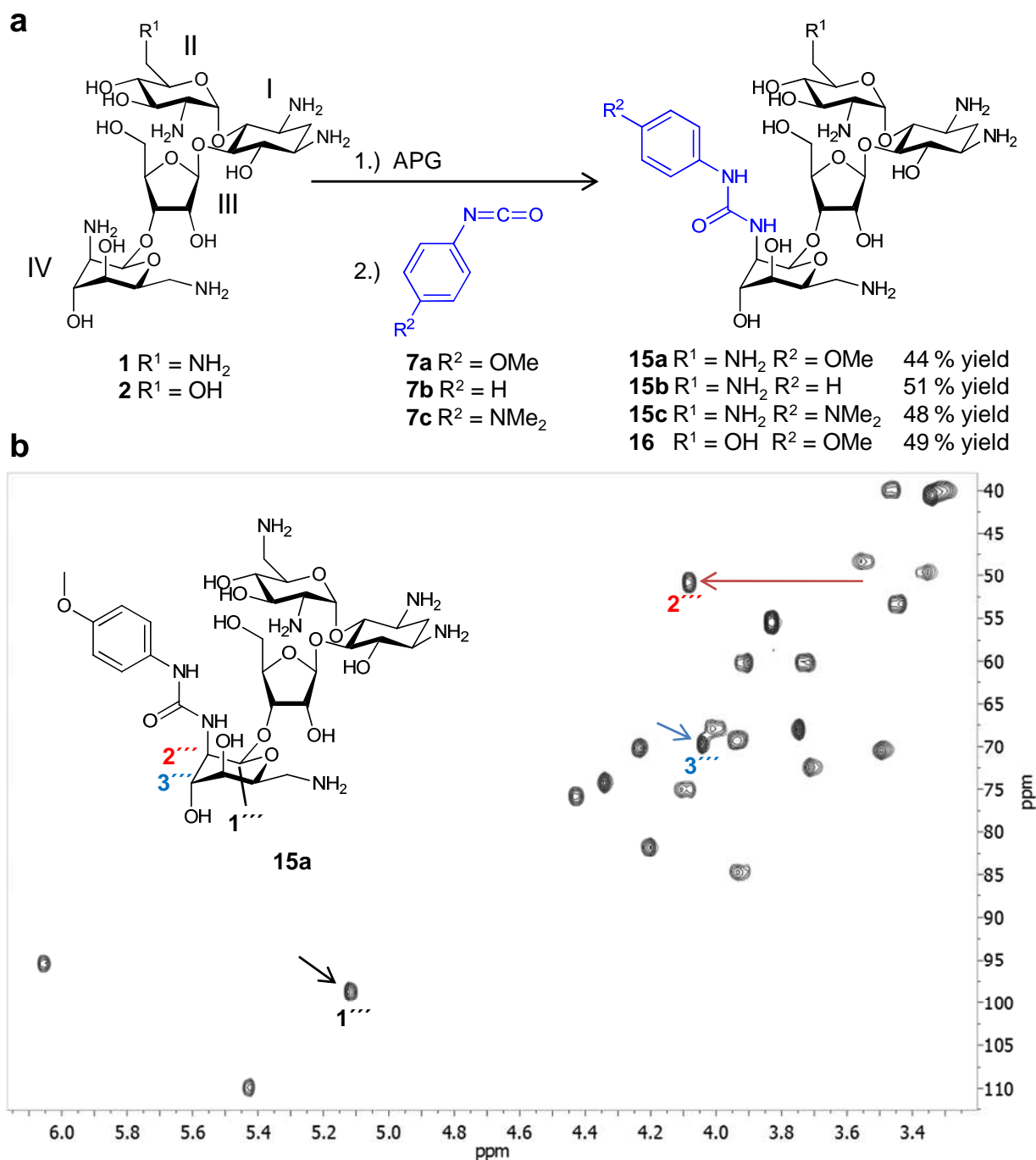

Figure 4.6: **a**, Regioselective transformation of the amino group in C2 position at ring IV of antibiotic **1** and **2** in presence of 1.5 equivalents APG **apt1** or **apt2** using 15 equivalents of aromatic isocyanates **7a-c**. Reactions were performed in 10 mM sodium phosphate buffer ($\text{pH} \approx 7$) containing 6.4 volume % DMF at room temperature and 24 hours reaction time. Yields of mono-urea derivatives (isomer mixture) were determined by HPLC. **b**, HSQC spectrum of neomycin B derivative **15a**. Chemical shifts of the $J(\text{C}1'''\text{-H})$ coupling (black arrow), $J(\text{C}2'''\text{-H})$ coupling (red arrow) and $J(\text{C}3'''\text{-H})$ coupling (blue arrow) indicate the regioselective urea bond formation in C2 position at ring IV.

Furthermore, we demonstrated that the urea group can be also introduced regioselectively in related antibiotic paromomycin **2** in presence of APGs **apt1** and **apt2**. Thus, antibiotic **2** was transformed successfully with isocyanate **7a** to the corresponding urea derivative **16** in presence of an APG (Fig. 4.6a, Table 4.2). It was found that **2** was also preferably transformed at the C2 position of ring IV with good conversions of 53 % and 52 % and excellent regioselectivities of 97 % and 92 % applying **apt1** and **apt2**, respectively (Table 4.2).

Table 4.2: Conversions and regioselectivities of urea bond formation in C2 position of antibiotic's ring IV.

Compound	APG	R ₁	R ₂	conv. [^] (%)	r.s. [*] (%)
15a **	apt1	NH ₂	OMe	49	>99
15a **	apt2	NH ₂	OMe	44	>99
15b **	apt1	NH ₂	H	44	>99
15b	apt2	NH ₂	H	37	>99
15c **	apt1	NH ₂	N(Me) ₂	51	92
15c	apt2	NH ₂	N(Me) ₂	57	93
16 **	apt1	OH	OMe	53	97
16	apt2	OH	OMe	52	92

All reactions were carried out according to the general procedure using 15 equiv. of aromatic isocyanates **7a-c** (see experimental part 4.4.2.3.2). [^] Conversions of neomycin B to corresponding derivatives were calculated from HPLC- and ¹H-NMR peak integrals. ^{*} Regioselectivities (r.s.) were calculated using ¹H-NMR spectroscopy. ^{**} Reaction was performed up to four times and average of conversion and regioselectivity is given. An error of the conversion is calculated to be up to 6 %.

The preferential modification of two different amino group at ring IV using urea formation and acylation reaction can be explained as a combination of two factors: as shown in Figure 4.7, the aromatic isocyanates **7a** exhibits a planar structure, while acetyl NHS ester **3** is a more sterically hindered molecule due to the presence of sp³-hybridized carbon atoms. Furthermore, in comparison to ester **3** the reactive unit of the isocyanates **7a** is smaller and additionally, not sterically hindered by a methyl group as it is the case for **3**. This enables the attack of the amino group in C2 position of ring IV protected partly by the APG. Additionally,

it seems that in aqueous medium isocyanates exhibit higher reactivity towards amines with lower pK_a value, i.e. amino groups attached to secondary carbon atoms in neomycin B.

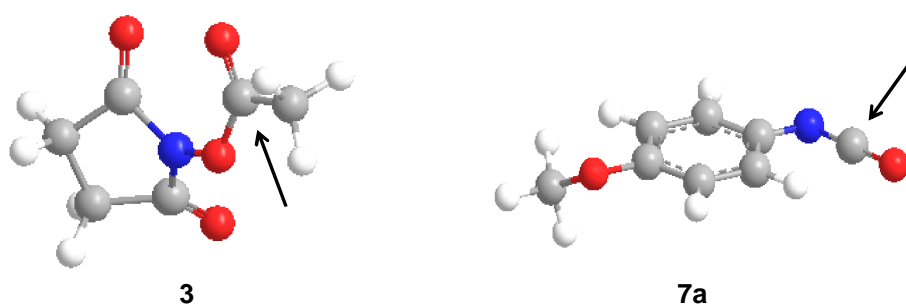

Figure 4.7: Simulated 3D-structures (*ChemDraw*) of acetyl NHS ester **3** and p-methoxyphenyl isocyanate **7a**. Color code: white – hydrogen, grey – carbon, blue – nitrogen, red – oxygen. Black arrows indicate the electrophiles for a nucleophilic attack.

This result showed that a detailed understanding of the interaction between APG and guest molecule together with careful choice of reagent and conditions enables a modification at different amino groups of antibiotic **1** and **2** using the same APG sequence.

4.2.3 Regioselective *Mono-* & *Di-*Functionalization of Neomycin B

After we applied successfully different reactions to enable region- and chemoselective modifications of two different positions at ring IV of neomycin B **1** and paromomycin **2** in presence of APGs, we investigate the selective *mono-* and *di-*functionalization of antibiotic **1** in presence of APG **apt1**. Therefore, we used a diazo-transfer reagent **8** to perform azide introduction and aliphatic isocyanates **9a-c** to enable urea formation at two amino groups of antibiotic's ring IV.

4.2.3.1 Regioselective Azide Introduction at Antibiotic's Ring IV

To introduce an azide group at ring IV of neomycin B, we utilized imidazole-1-sulfonyl azide hydrochloride **8** as diazo-transfer reagent (Fig. 4.8). "Diazo donor" **8** was introduced by *Goddard-Borger* and *Stick* in 2007 as an efficient, shelf-stable and water soluble reagent.²⁴ Moreover, investigation of **8** showed its convenient applicability in aqueous media using mild conditions and without the use of transition metal catalysts, such as copper(II), nickel(II), and zinc(II).²⁵ Furthermore, reagent **8** was applied successfully for the regioselective azide

introduction in structurally complex natural products, namely peptides²⁵ and neamine antibiotics (chapter 5), in aqueous solution. Here, we demonstrate a regioselective azide introduction in neomycin B employing **8** in presence of the APG **apt1**. We performed the transformation applying basic conditions (pH 8), copper(II) sulfate as catalyst and eight equivalents of reagent **8** in presence and absence of **apt1**. Under these conditions the reaction of neomycin B in presence of **apt1** resulted in a mixture of antibiotic derivatives exhibiting one and two azide groups (see experimental part Fig. 4.26), while in absence of the APG mainly hexa-azido derivatives were detected (see experimental part Fig. 4.19). The *mono*- and *di*-functionalized antibiotic derivatives formed in presence of the APG could be separated by HPLC purification and were obtained with a yield of 46 % and 16 %, respectively. Their characterization by NMR spectroscopic measurements showed that reagent **8** reacted exclusively with the amino groups at ring IV of the antibiotic **1** resulting in *mono*-azide **17** and *di*-azide **18** (Fig. 4.8).

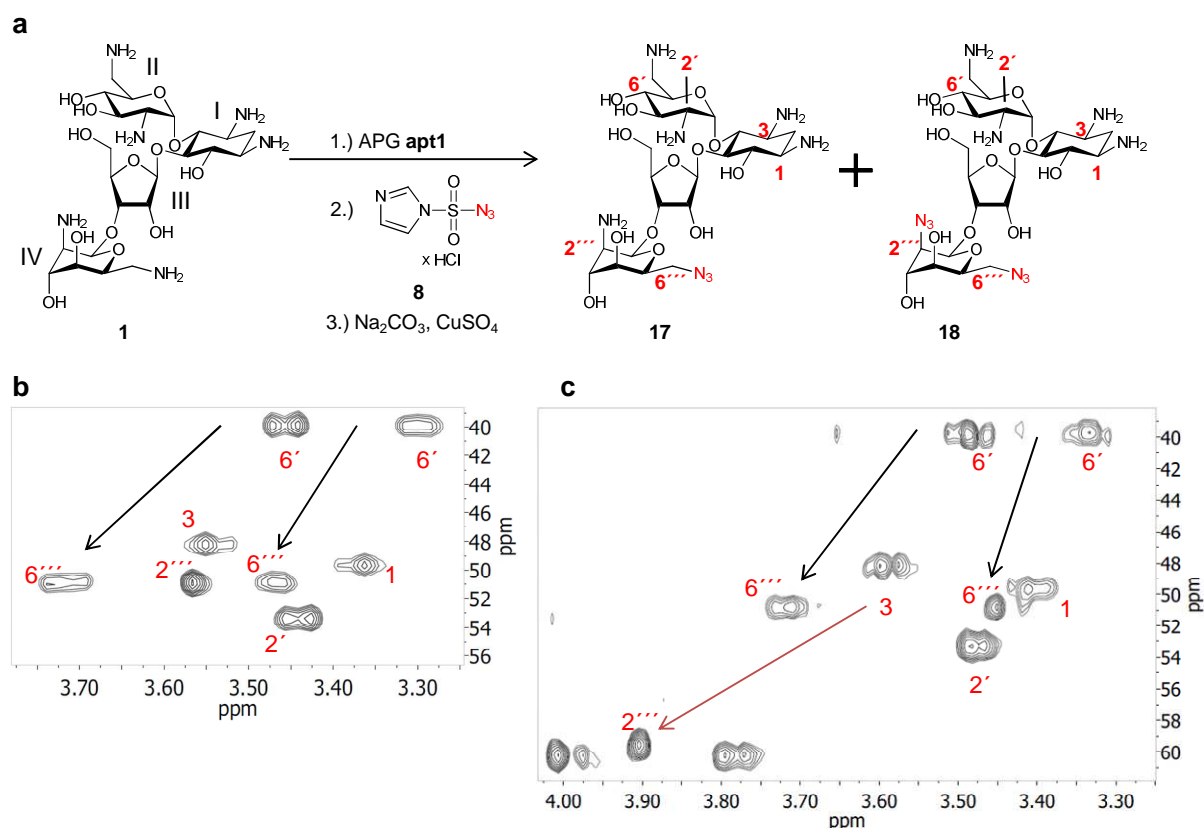

Figure 4.8: a, Regioselective azide introduction in neomycin B in presence of 1.5 equivalents APG **apt1** using 8 equiv. of diazo-transfer reagent **8**. Reaction was performed in 10 mM sodium phosphate buffer (pH \approx 8) at room temperature and 24 hours reaction time. b, HSQC-section of *mono*-azido neomycin B derivative **17**. Chemical shifts of the $J(\text{C6}'''\text{-H})$ couplings (black arrows) indicate the regioselective azide introduction in C6 position at ring IV. c, HSQC-section of *di*-azido neomycin B derivative **18**. Chemical shifts of the $J(\text{C6}'''\text{-H})$ couplings (black arrows) and $J(\text{C2}'''\text{-H})$ coupling (red arrow) indicate the regioselective azide introduction in C6 and C2 position at ring IV, respectively.

As proven by 2D-NMR spectra, *mono*-azido derivative **17** exhibits the azide group in C6 position and the *di*-azido derivative **18** in C2 and C6 position of ring IV (Fig. 4.8b and 4.8c). Employing 1D-NMR spectroscopy, regioselectivities up to 93 % were determined for the azide introduction (see experimental part Fig. 4.15a and 4.16a).

However, neomycin B was transformed to derivatives **17** and **18** with conversions of approx. 48 % and 17 %, respectively. From this result we can conclude that the amino group in C6 position is more reactive than the one in C2 position of ring IV, since the amine in C6 position of **1** is transformed in both antibiotic derivatives to an azide. The additional minor conversion of the amino group in C2 position resulting in *di*-azido derivative **18** can be explained in two ways. On the one hand, the reactive azide function of the reagent **8** is not sterically hindered, enabling an attack of the amine in C2 position of ring IV, as described previously for isocyanates (paragraph 4.2.2). On the other hand, the sodium concentration was increased to approx. 21 mM as an effect of pH adjustment using sodium hydroxide and sodium carbonate. Since the binding constant between aptamer **apt1** and antibiotic **1** is lower with the increase of salinity (chapter 3),¹⁷ it can be assumed that the destabilization of the complex enables also the transformation of the amino group in C2 position.

It can be summarized that, despite of basic conditions, presence of copper(II) as catalyst and increased sodium concentration, excellent regioselectivities were achieved employing imidazole-1-sulfonyl azide hydrochloride **8** as diazo-transfer reagent. This result demonstrates the robustness of the RNA aptamers as APGs for the modification of aminoglycoside antibiotics. Furthermore, the regioselective introduction of azide groups has several advantages. On the one hand, an azide group can be applied as a protective group enabling selective modification of other amino groups of neomycin B. On the other hand, azides can be further transformed in a single step into 1,2,3-triazoles *via* “click-chemistry” employing *Huisgen* reaction²⁶ and into amides and carbamates using *Staudinger* reaction²⁷ that could result in a broad spectrum of new antibiotic derivatives.

4.2.3.2 Regioselective Urea Bond Formation at Antibiotic's Ring IV

In the previous paragraph, we described a successful regioselective azide introduction in C2- and C6 position at ring IV of neomycin B in presence of APG **apt1**. Our studies demonstrated that at first place the amino group in C6 position was transformed regioselectively resulting in 6''-azido neomycin B **17**, while in further course of the reaction the amino group in C2

position of **17** was transformed yielding 6''', 2'''-diazido neomycin B **18**. In contrast, here we present a different reaction sequence of both amines at ring IV of the antibiotic **1** in presence of **apt1**. For this purpose we utilized the introduction of urea groups employing aliphatic isocyanates **9a-c**. As shown in Figure 4.9a, neomycin B was reacted with 30 equivalents of propyl isocyanates **9a** in presence of APG **apt1**. With HPLC analysis (experimental part Fig. 4.27) of the reaction mixture it was demonstrated that the transformation of **1** resulted mainly in *mono*- and *di*-substituted derivatives reaching yields of 21 % and 31 %, respectively (Table 4.3). After separation of neomycin B derivatives exhibiting one and two urea groups by HPLC purification, the obtained derivatives were characterized by NMR spectrometric measurements. As show in Figure 4.9a, neomycin B was transformed to the *mono*-urea derivative **19a** and *di*-urea derivative **20a**.

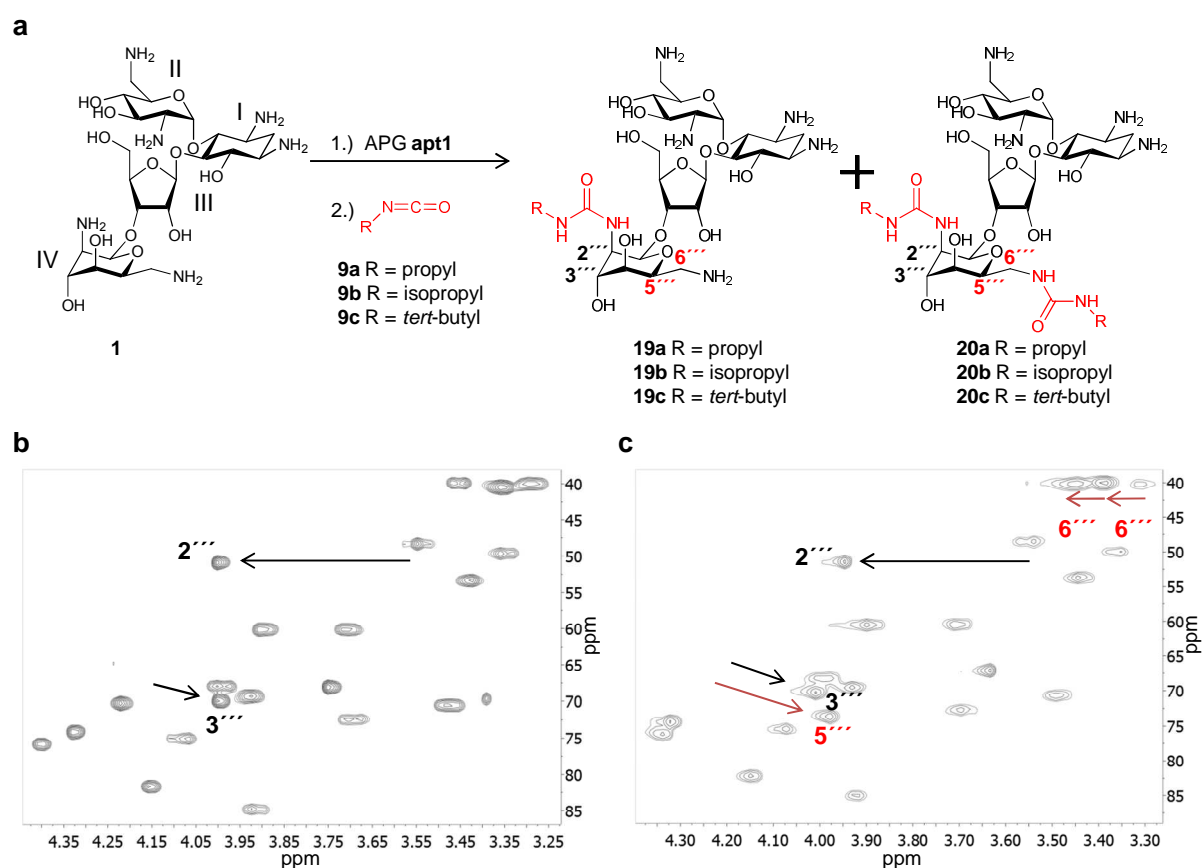

Figure 4.9: **a**, Regioselective transformation of neomycin B in presence of 1.5 equivalents **apt1** using 30 equiv. of aliphatic isocyanates **9a-c**. Reactions were performed in 10 mM sodium phosphate buffer (pH \approx 7) containing 6.4 volume % DMF at room temperature and 24 hours reaction time. **b**, HSQC-section of neomycin B derivative **19a**. Chemical shifts of the $J(C2'''-H)$ - and $J(C3'''-H)$ coupling (black arrows) indicate the selective reaction of the amino group in C2 position at ring IV. **c**, HSQC-section of neomycin B derivative **20a**. Chemical shifts of the $J(C2'''-H)$ - and $J(C3'''-H)$ coupling (black arrows) and of the $J(C5'''-H)$ - and $J(C6'''-H)$ coupling (red arrows) indicate the transformation of amines in C2 and C6 position at ring IV, respectively.

Employing 2D-NMR spectroscopy it was proven that the derivative **19a** exhibits the urea group in C2 position at ring IV (Fig. 4.9b), while derivative **20a** has two urea functionalities in C2- and C6 position at ring IV (Fig. 4.9c). As calculated from ¹H-NMR spectra, the *mono*-functionalization and *di*-functionalization of antibiotic **1** reached excellent regioselectivities of 90 % and >99 % for **19a** and **20a**, respectively (Table 4.3, experimental part Fig. 4.17a and Fig. 4.18a).

In comparison to the azide introduction (reaction in C6 position, then in C2 position), applying aliphatic isocyanates an opposite order of reaction of amino groups at antibiotic's ring IV was determined (first C2 position, then C6 position). This difference can be explained as follows. On the one hand, isocyanates react preferably with amino groups located at the secondary carbon atoms (C2 position) under the applied conditions, as demonstrated in paragraph 4.2.2 for aromatic isocyanates. Thus, neomycin B is first converted to *mono*-urea derivative **19a** (Fig. 4.9a). On the other hand, aliphatic isocyanates show reactivity with all amines of antibiotic **1** resulting in derivatives containing five and six urea group in absence of APG (see experimental part Fig. 4.20, 4.21 and 4.22). As a consequence, the additional reactivity of the amino group in C6 position at ring IV leads finally to the regioselective formation of *di*-urea derivative **20a** in presence of **apt1** (Fig. 4.9a).

To test whether sterically more demanding aliphatic isocyanates are applicable, antibiotic **1** was reacted with isopropyl- (**9b**) and *tert*-butyl- (**9c**) isocyanate (Fig. 4.9a). The application of 30 equivalents of reagents **9b** resulted in the corresponding *mono*-urea regioisomer **19b** and *di*-urea derivative **20b**, while employing **9c** the transformation occurred only in a single position at the antibiotic **1** resulting in derivative **19c** (Fig. 4.9a, Table 4.3). Furthermore, it turned out that the conversion of neomycin B to *di*-urea derivative **20b** was decreased to 21 % employing isocyanates **9b** in comparison with the less sterically demanding isocyanate **9a** reaching 35 % for derivative **20a** (Table 4.3). In contrast, the conversions of neomycin B to the *mono*-urea regioisomers **19b** and **19c** increased to 35 % and 42 % using sterically more demanding isocyanates **9b** and **9c**, respectively. The reduced formation of *di*-substituted isomers **20b** and absence of *di*-urea derivative **20c** applying more sterically demanding isocyanates can be explained by the size of the introduced residues at the amine in C2 position in the first place. After transformation of the amine in C2 position the introduced urea group is hindering the reaction of the amino group in C6 position, resulting in decreased or prevented formation of *di*-substituted derivatives. However, all derivatives were formed with

extremely high regioselectivities ranging from 90 % to 95 % employing isocyanates **9b** and **9c** (Table 4.3).

Table 4.3: Conversions and regioselectivities of *mono*- and *di*-functionalization of neomycin B.

Product	R	conv. [^] (%)	yield*(%)	r.s.**(%)
19a	propyl	24	21	91
19b	isopropyl	35	32	90
19c	<i>tert</i> -butyl	42	38	95
20a	propyl	35	31	>99
20b	isopropyl	21	17	95
20b ^{^^}	isopropyl	n.d.	-	-

All reactions were carried out according to the general procedure using 30 equiv. of aliphatic isocyanates **9a-c** in presence of 1.5 equiv. **apt1** (see experimental part 4.4.2.3.2). [^] Conversions of **1** to antibiotic derivatives were calculated from HPLC- and ¹H-NMR peak integrals. ^{^^} Derivative was not detectable (n.d.) by HPLC analysis. * Yields of *mono*- and *di*-urea derivatives (isomer mixture) were determined by HPLC. ** Regioselectivities (r.s.) were calculated using ¹H-NMR spectroscopy.

Summarized, this result demonstrates that the order of transformation of the amino groups at ring IV of neomycin B is determined by the choice of chemical transformation. Employing urea bond formation, the amine in C2 position was reacted first and then the created *mono*-urea derivatives **19a-c** were transformed to *di*-urea derivatives **20a-b**. Reaction of neomycin B with diazo-transfer reagent **8** resulted first in the antibiotic derivative **17** modified in C6 position and then in *di*-azido derivative **18** transformed in C6 and C2 position (paragraph 4.2.3.1).

4.3 Conclusion

In this chapter, we investigated six different reagents and four different reactions regarding their applicability for the modification of two antibiotics, namely neomycin B and paromomycin, in presence of two different APGs. We successfully employed acylation, thiolation, urea bond formation and azide introduction as reactions in presence of APG **apt1** reaching moderate yields and excellent regioselectivities. At this point it has to be emphasized that the APG-technology allows not only the application of neutral reagents but also positively and negatively charged ones for modification. Moreover, it was shown that the application of the same RNA aptamers as APGs allows the transformation of different positions at ring IV of the aminoglycosides. Using **apt1** as APG the amino group in C6 position at ring IV of neomycin B was acylated using a STP ester and 2-iminothiolane hydrochloride with regioselectivities of 83 % and 91 %, respectively. In the same position an azide group was introduced regioselectively applying imidazole-1-sulfonyl azide hydrochloride reaching a regioselectivity of 93 %. In contrast, the amino group in C2 position at ring IV of neomycin B and paromomycin was converted to urea groups using aliphatic and aromatic isocyanates in presence of APGs **apt1** and **apt2** reaching regioselectivities up to >99 %. Furthermore, it was successfully demonstrated that by choosing reagents and conditions properly, azide- and urea groups could be introduced regioselectively in both positions at ring IV of neomycin B resulting in *di*-azido- and *di*-urea antibiotic derivatives using imidazole-1-sulfonyl azide hydrochloride and aliphatic isocyanates as reagents, respectively. Summarized, these results show the wide applicability of APGs allowing a broad range of chemo- and regioselective modifications of aminoglycoside antibiotics. Employing various reactions for the transformation in different positions, this study helps to accelerate the search for new active compounds based on neamine antibiotics using RNA aptamers as APGs. The aminoglycoside derivatives described in this chapter are particularly suited as starting point for the generation of libraries of this class of antibiotics, because they can be reacted further by a large variety of organic reactions.

4.4 Experimental Section

4.4.1 Materials & Methods

¹H-NMR-, heteronuclear single-quantum correlation (HSQC) spectra and Attached Proton Test (APT) were recorded on a Varian Unity Inova (500 MHz for ¹H-NMR and HSQC, 125 MHz for APT and ¹³C-NMR), Oxford AS400 (400 MHz for ¹H-NMR and 100.6 MHz for APT and ¹³C-NMR) and Oxford 600 (600 MHz for ¹H-NMR and HSQC) NMR spectrometer at 25 °C. High resolution mass spectrometry (HRMS) was carried out on a LTQ ORBITRAP XL instrument (*Thermo Scientific*) employing electron impact ionization in positive ion mode (EI+). Chromatographic separations were carried out on a *Shimadzu* VP series high performance liquid chromatography (HPLC) modular system (DGU-14A3 Online Vacuum-Degasser, two LC-20 AT pumps, SIL-20A auto sampler, CTP-20 A column oven, RID-10 refractive detector, FRC-10 A fraction collector and *Shimadzu* LCsolution software). HPLC purification was performed with a *Waters* Spherisorb ODS-2 C₁₈ analytical column (250 x 4.6 mm, spherical particles of 5 μm and 80 Å pore size) using isocratic elution at 40 °C. A pH-meter (*Hanna Instruments* pH 209) equipped with a glass combination electrode was used for pH adjustments of the reaction buffers. All chemicals and reagents were purchased from commercial suppliers and used without further purification, unless otherwise noted. Neomycin B trisulfate x hydrate (VETRANAL[®]), paromomycin sulfate salt (98 %), *N,N*-dimethylformamide (DMF, 99 %), *N*-hydroxysuccinimide (NHS, 98 %), trifluoroacetic acid anhydride (99 %), dichloromethane (DCM, 99.5 %), tetrahydrofuran (THF, 99.9 %), pyridine (99 %), 4-pentynoic acid (95 %), acetic acid (99 %), 4-methoxyphenyl isocyanate (99 %), phenyl isocyanate (98 %), 4-(dimethylamino)-phenyl isocyanate (97 %), propyl isocyanate (99 %), isopropyl isocyanates (98 %), *tert*-butyl isocyanate (97 %), 2-iminothiolane hydrochloride (98 %), and toluene (99.8 %), sulfuryl chloride (97 %), sodium azide (95 %), acetonitril (99.8 %), imidazole (99 %), methanolic 3N HCl solution, sulfuric acid (30 % SO₃) and *di*-cyclohexylcarbodiimide (99 %) were purchased from *Sigma Aldrich* and used as received. 2,3,5,6-*tetra*-fluoro phenol (98 %) was purchased from *Acros Organics*. For HPLC purification heptafluorobutyric acid (HFBA) (*Fluka*, puriss. p.a., for ion chromatography) and acetone (*Sigma-Aldrich*, HPLC grade) were used. Ultrapure water (specific resistance > 18.4 MΩ cm) was obtained by Milli-Q water purification system (*Sartorius*[®]). RNA aptamers (82 – 91 % purity) were purchased from *BioSpring* (Frankfurt am Main, Germany) and *riboxx* GmbH (Radebeul, Germany). For the regioselective

transformation Milli-Q water was treated with diethylpyrocarbonate (DEPC) and sterilized using an autoclave (121 °C, 20 min).

4.4.2 General Procedures

4.4.2.1 Synthesis & and Characterization of Reagents for Antibiotic Modifications

Synthesis of Diazo-Transfer Reagent Imidazole-1-sulfonyl Azide Hydrochloride (8)²⁴

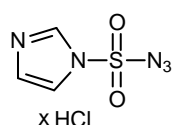

A volume of 1.6 mL of sulfonyl chloride (20 mmol) was added drop wise to an ice-cooled suspension of 1.3 g sodium azide (20 mmol) in 20 mL acetonitril and the mixture was stirred overnight at room temperature. Then 2.6 g of imidazole (38 mmol) were added portion-wise to the ice-cooled mixture and the resulting slurry was stirred for additional 3h at room temperature. The reaction mixture was diluted with ethyl acetate 40 mL, washed twice with 40 mL water and then twice with 40 mL sat. aq. NaHCO₃ solution, dried over MgSO₄ and filtered. The filtrate was cooled in an ice-batch and a 10 mL of a 3M HCl methanolic solution were added drop wise to precipitate the product. Finally, the filter cake was washed three times with 10 mL ethyl acetate to obtain **7** as colorless hydrochloride salt. Yield: 1.9 g (9.1 mmol, 45% yield). ¹H-NMR (D₂O, 400 MHz) δ (p.p.m.) 9.53 (s, 1H, H-2), 8.07 (s, 1H, H-5), 7.67 (s, 1H, H-4). ¹³C-NMR (D₂O, 100.6 MHz) δ (p.p.m.) 137.6, 122.6, 120.18. HRMS (EI+) (*m/z*): found 174.0078 [M-Cl]⁺, calc. 174.0080 [M-Cl]⁺.

Synthesis of Acetyl Sulfo-Succinimide Ester (4)¹⁵

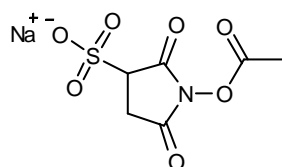

A volume of 136 μL (2.31 mmol) acetic acid and 500 mg (2.56 mmol) sulfo-*N*-hydroxysuccinimide were dissolved into 6.25 ml DMF. To this solution 600 mg (2.8 mmol) of 1,3-dicyclohexylcarbodiimide (DCC) were added and the solution was stirred for 24 hours. This solution was cooled to 4 °C and the precipitate (urea) is filtered. To this filtrate were added 200 ml of a ethyl acetate – hexane (1:1) mixture and this mixture was stirred for 30 min and stored at 4 – 8 °C over weekend. The precipitate is collected though filtration and then dried in a desiccators to obtain **4** as a white solid. Yield: 353 mg (1.36 mmol, 59%). ¹H-NMR (D₂O, 400 MHz) δ (p.p.m.) 4.53 (d, 1H, J = 7.2, CH-S); 3.43 (dd, 1H, J = 18.8, J = 8.8, CH₂^a); 3.24

(dd, 1H, $J = 19.2$ Hz, $J = 3.2$ Hz, CH_2^b); 2.45 (s, 3H, $\text{CH}_3\text{-CO}$). ^{13}C -NMR (D_2O , 100.6 MHz): δ (p.p.m.) = 170.11, 168.90, 167.40 (3C, CO); 56.25 (1C, C- SO_2); 29.50 (1C, CH_2); 16.85 (1C, $\text{CH}_3\text{-CO}$).

Synthesis of Sodium 4-(acetoxy)-2,3,5,6-tetra-fluorobenzenesulfonate (**5**)¹⁶

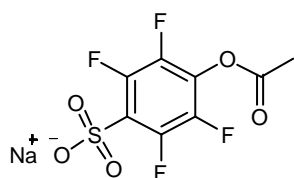

A amount of 10.1 g of 2,3,5,6-tetrafluorophenol (61.4 mmol) were taken up in 22 mL fuming sulphuric acid (30 % SO_3) and stirred at ambient temperature for 18 hours before pouring the mixture into 200 mL iced brine. The product was precipitated by adding 6 g of NaCl and stirred until no further precipitate was formed. This mixture was filtered through a sintered glass disc and the collected solids were taken up in 330 mL boiling acetonitril, filtered while hot, and allowed to cool slowly to ambient temperature. The colourless crystalline product was collected by filtration and dried in vacuum yielding 5.42 g (20.2 mmol, 33 % yield) of 4-sulfo-tetrafluorophenol sodium salt. 270 mg of this salt (1.0 mmol) and 53.8 μL of acetic acid (0.94 mmol) were dissolved in 30 mL acetone. After 230 mg DCC (1.1 mmol) were added, the mixture was stirred at room temperature for 20 hour. The resulting precipitate was removed by filtration and the filtrate was concentrated under reduced pressure. The crude mixture was purified by column chromatography using a 4:1 acetone/chloroform mixture to yield **5** as a white solid: Yield 163 mg (0.53 mmol, 56 % yield). R_f (acetone/chloroform 4:1) = 0.55. ^1H -NMR (D_2O , 400 MHz) δ (p.p.m.) 2.46 (s, 3H, $\text{CH}_3\text{-CO}$). ^{13}C -NMR (D_2O , 50.43 MHz): δ (p.p.m.) = 170.07 (1C, CO); 147.01 (dq), 144.09 (ddd) (2C, 3-C-Ar, 5-C-Ar); 145.03 (dq), 142.10 (ddd) (2C, 2-C-Ar, 6-C-Ar), 131.14 (1C, C- SO_2); 127.61 (1C, C-CO- CH_3); 22.82 (1C, $\text{CH}_3\text{-CO}$).

4.4.2.2 Regioselective Transformation of Antibiotic's Ring IV

4.4.2.2.1 Acylation in C6 Position of Neomycin B

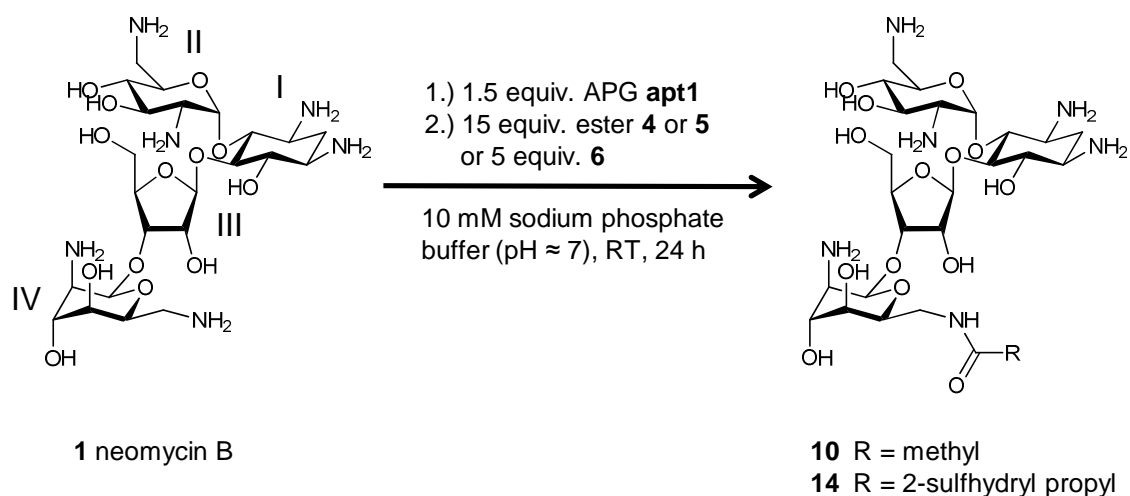

Scheme 4.3: Regioselective transformation of amino group in C6 position of ring IV.

A volume of 300 μL of a 5.54 mM RNA aptamer solution (1.66 μmol) in 10 mM sodium phosphate buffer (pH 6.8) was heated to 85 $^{\circ}\text{C}$ for 10 min and was afterwards kept at room temperature for 15 min. Then, 228 μL of a 4.8 mM solution of neomycin B sulphate (1.09 μmol) in 10 mM sodium phosphate buffer (pH 7.4) were added and the mixture was allowed to stand for 30 min at room temperature. Then, 15 equiv. of activated ester, acetyl sulfo-NHS ester **4** or STP-ester **5** (16.4 μmol) in 500 μl of 10 mM sodium phosphate buffer (pH 7.4), or 5 equiv. of 2-iminothiolane hydrochloride (16.4 μmol) dissolved in 42 μL of 10 mM sodium phosphate buffer (pH 7.4) were added and the reaction mixture was allowed to react for 24 hours at room temperature. After addition of 60 μL of aq. 7 wt. % ethylamine solution and further incubation for 30 min at room temperature, 162 μl (acylation with activated ester) or 90 μl (thiolation with 2-iminothiolane HCl) of 2M NaOH solution were added, heated to 85 $^{\circ}\text{C}$ for 30 min and cooled to room temperature. To obtain sufficient amount of aminoglycoside derivatives, this entire procedure was repeated twice and the three resulting reaction mixtures were combined before each 50 μL fraction was purified by HPLC using a *Waters Spherisorb ODS-2C₁₈* analytic column (water/acetone 1:0.81 containing 16.9 mM HFBA) at a flow rate of 1 ml/min at 40 $^{\circ}\text{C}$ to afford the antibiotic derivatives **10** and **14**. After evaporation of acetone and freeze drying of collected fractions the product was dissolved in 150 μL of D_2O for NMR studies.

4.4.2.2.2 Urea Bond Formation in C2 & C6 Position of Neomycin B

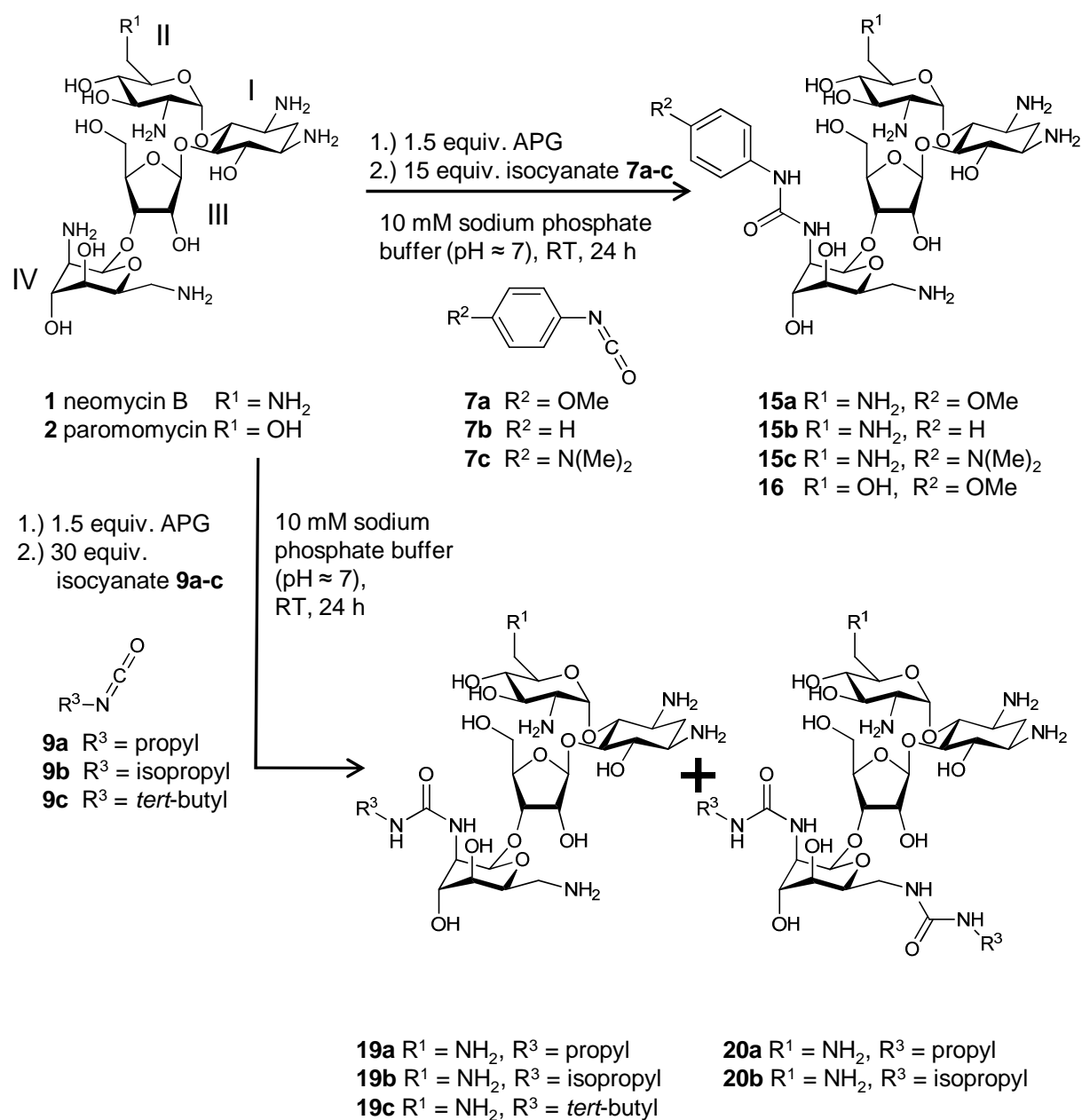

Scheme 4.4: Mono- and di-functionalization at ring IV of antibiotics **1** and **2**.

A volume of 300 μL of a 5.54 mM RNA aptamer solution (1.66 μmol) in 10 mM sodium phosphate buffer (pH 6.8) was heated to 85 $^\circ\text{C}$ for 10 min and was afterwards kept at room temperature for 15 min. Then, 228 μL of a 4.8 mM solution of the aminoglycoside antibiotic (1.09 μmol) in 10 mM sodium phosphate buffer (pH 7.4) were added and the mixture was allowed to stand for 30 min at room temperature. Afterwards, 15 equiv. (16.4 μmol) of aromatic isocyanate **7a-c** or 30 equiv. (49.2 μmol) of aliphatic isocyanates **9a-c** dissolved in 36 μL DMF were added and the reaction mixture was allowed to react for 24 hours at room

temperature. After addition of 60 μL of aq. 7 wt. % ethylamine solution and further incubation for 30 min at room temperature, 93 μL of aq. 2 M NaOH solution were added and the crude mixture was heated to 85 $^{\circ}\text{C}$ for 30 min and cooled to room temperature. To obtain sufficient amount of aminoglycoside derivatives, this procedure was repeated twice and the three resulting reaction mixtures were combined before each 50 μL fraction was purified by HPLC using a *Waters Spherisorb ODS-2* C_{18} analytic column (water/acetone 1.0:0.81 containing 16.9 mM HFBA) at a flow rate of 1 ml/min at 40 $^{\circ}\text{C}$ to afford the antibiotic derivatives **15a-c**, **16**, **19a-c** and **20a-b**. After evaporation of acetone and freeze drying the product was dissolved in 150 μL of D_2O for NMR studies.

4.4.2.2.3 Azide Introduction in C2 and C6 Position of Neomycin B

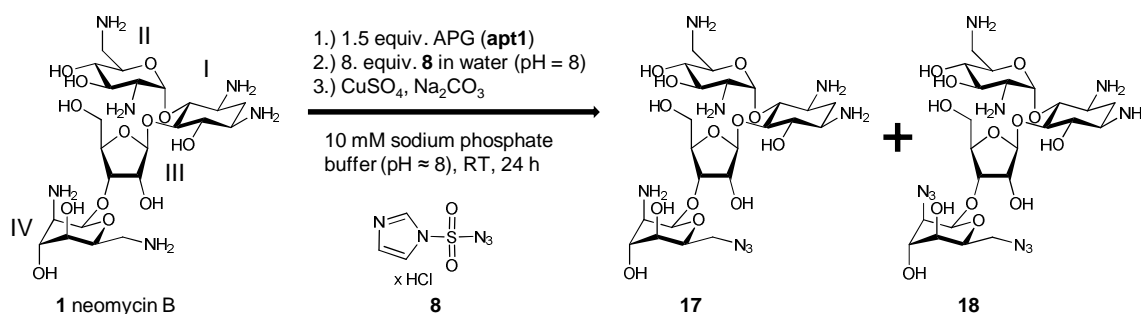

Scheme 4.5: Regioselective transformation of amino group in C2 and C6 position of ring IV.

A volume of 300 μL of a 5.54 mM RNA aptamer solution (1.66 μmol) in 10 mM sodium phosphate buffer (pH 6.8) was heated to 85 $^{\circ}\text{C}$ for 10 min and was afterwards kept at room temperature for 15 min. Then, 228 μL of a 4.8 mM solution of neomycin B sulphate (1.09 μmol) in 10 mM sodium phosphate buffer (pH 7.4) were added and the mixture was allowed to stand for 30 min at room temperature. Afterwards, 180 μL of an aqueous solution of diazo-transfer reagent **8** (10 mg/mL, adjusted to pH 8 by adding of approx. 25 μL aq. 2 M NaOH solution), were added into the solution of the aptamer complex solution. Finally, a volume of 59 μL of an aqueous solution of sodium carbonate (10 mg/mL) and 50 μL of an aqueous solution of copper sulfate (2 mg/mL) were added and the mixture was allowed to react for 24 hours at room temperature. After addition of 60 μL of aq. 7 wt. % ethylamine solution and further incubation for 30 min at room temperature, 125 μL of aq. 2 M NaOH solution were added and the crude mixture was heated to 85 $^{\circ}\text{C}$ for 30 min and cooled to room temperature. To obtain sufficient amount of aminoglycoside derivatives, this entire procedure was repeated twice and the three resulting reaction mixtures were combined before each 50 μL fraction was

purified by HPLC using a *Waters Spherisorb ODS-2C₁₈* analytic column (water/acetone 1.0:0.81 containing 16.9 mM HFBA) at a flow rate of 1 ml/min at 40 °C to afford the antibiotic derivatives **17** and **18**. After evaporation of acetone and freeze drying of collected fractions the product was dissolved in 150 μ L of D₂O for NMR studies.

4.4.3 Characterization of Synthesized Antibiotic Derivatives

6'''-N-acetyl neomycin B x 5 HFBA (10). The title compound was prepared according to the

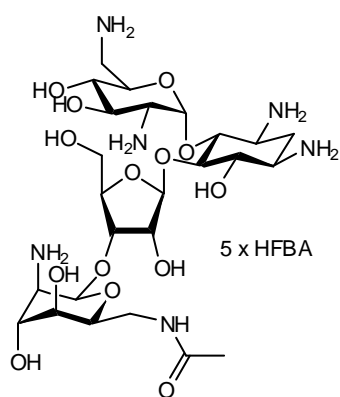

general procedure described above. Derivative **10** was obtained as a white solid. For the measurement of regioselectivity and the characterization of the compound ¹H-NMR, HSQC as well as APT spectra were recorded and electro spray ionization (ESI) MS was employed. The yield was calculated from ¹H-NMR- and HPLC peak integrals: R_t = 7.5 min, 30 % yield (apt1). TLC (CHCl₃/MeOH/17% NH₄OH 2:1:1 v/v/v) R_f = 0.52. ¹H-NMR (D₂O, 500 MHz) δ (p.p.m.) 6.06 p.p.m. (d, J = 4 Hz, 1H, 1-H'),

5.44 (d, J = 2 Hz, 1H, 1-H''), 5.20 (d, J = 1.5 Hz, 1H, 1-H'''), 4.44 (t, J = 5.75 Hz, 1H, 3-H''), 4.39 (dd, J = 5 Hz, J = 2 Hz, 1H, 2-H''), 4.26 (t, J = 3 Hz, 1H, 3-H'''), 4.24 (m, 1H, 4-H''), 4.09 (t, J = 6.75 Hz, 1H, 5-H'''), 4.07 (m, 1H, 4-H), 4.01 (t, J = 10 Hz, 1H, 5-H'), 3.98 – 3.92 (m, 3H, 5-H_a'', 5-H, 3-H'), 3.76 (dd, 1H, J = 12.5 Hz, J = 5.5 Hz, 5-H_b''), 3.72- 3.68 (m, 2H, 4-H''', 6-H), 3.60 (dd, J = 14 Hz, J = 7.5 Hz, 1H, 6-H_a''), 3.56 (m, 2H, 3-H, 2-H'''), 3.53- 3.41 (m, 4H, 6-H_a', 2-H', 6-H_b'', 4-H'), 3.38 (m, 1H, 1-H), 3.32 (dd, J = 14 Hz, J = 6 Hz, 1H, 6-H_b'), 2.51 (dt, J = 12.5 Hz; J = 3.8 Hz, 1H, 2-H_{eq}), 2.04 (s, 3H, CH₃), 1.89 (dd, J = 12.7 Hz, 1H, 2-H_{ax}). APT (D₂O, 125.7 MHz) δ (p.p.m.) 174.49 (Carbonyl-C), 110.00 (C-1'), 95.51 (C-1'''), 95.49 (C-1'), 84.62 (C-5), 81.66 (C-4'), 75.39 (C-3'), 75.29 (C-4), 73.58 (C-2'), 72.45 (C-5'''), 72.42 (C-6), 70.35 (C-4'), 69.22 (C-3'), 67.88 (C-5'), 67.56 (C-3'''), 66.10 (C-4'''), 60.00 (C-5'), 53.15 (C-2'), 50.90 (C-2'''), 49.65 (C-1), 48.16 (C-3), 39.85 (C-6'), 39.33 (C-6'''), 27.88 (C-2), 21.74 (CH₃). MS (EI+) (*m/z*): found 657.33008 [M+H]⁺, 679.31226 [M+Na]⁺; calculated 657.33013 [M+H]⁺, 679.31207 [M+Na]⁺.

6'''-N- γ -sulphydryl-propionyl neomycin B x 5 HFBA (14). The title compound was

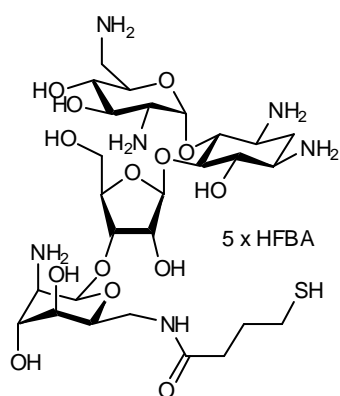

prepared according to the general procedure described above.

Derivative **14** was obtained as a white solid. For the measurement of regioselectivity and the characterization of the compound $^1\text{H-NMR}$ and HSQC spectra were recorded and electro spray ionization (ESI)-MS was employed. The yield was calculated from $^1\text{H-NMR}$ - and HPLC peak integrals: $R_t = 16.3$ min, 30 % yield (apt1). $^1\text{H-NMR}$ (D_2O , 500 MHz) δ (p.p.m.) 6.03 (s, 1H, 1-H'), 5.42 (s, 1H, 1-H''), 5.18 (s, 1H, 1-H'''), 4.44-4.35 (m, 2H, 3-H'', 2-H''), 4.26-4.12 (m, 2H, 3-H''', 4-H''), 4.11-4.04 (m, 2H, 4-H, 5-H'''), 4.00 (t, $J = 10.3$ Hz, 1H, 3-H'), 3.96-3.89 (m, 3H, 5-H, 5-H', 5-H_a''), 3.77-3.67 (m, 3H, 5-H_b'', 6-H, 4-H'''), 3.58-3.43 (m, 7H, 3-H, 2-H''', 6-H_a'', 6-H_b'', 6-H_a', 4-H', 2-H'), 3.37 (dt, $J = 10.5$ Hz, $J = 4.5$ Hz, 1H, 1-H), 3.28 (dd, $J = 14$ Hz, $J = 6$ Hz, 1H, 6-H_b'), 2.75 (q, $J = 7$ Hz, 2H, γ -CH₂), 2.50 (dt, $J = 12.5$ Hz, $J = 3.5$ Hz, 1H, 2-H_{eq}), 2.38 (t, $J = 7.3$ Hz, 2H, α -CH₂), 2.02-1.87 (m, 3H, β -CH₂, 2-H_{ax}). ^{13}C -signals based on HSQC (D_2O , 500 MHz) δ (p.p.m.) 110.3 (C-1'), 95.9 (C-1'''), 95.6 (C-1'), 84.9 (C-5), 81.8 (C-4''), 76.1 (C-3''), 75.4 (C-4), 74.1 (C-2''), 72.8 (C-5'''), 72.5 (C-6), 70.8 (C-4'), 69.5 (C-3'), 68.2 (C-5'), 67.7 (C-3'''), 66.4 (C-4'''), 60.5 (C-5''), 53.6 (C-2'), 51.1 (C-2'''), 49.9 (C-1), 48.5 (C-3), 40.2 (C-6'), 39.5 (C-6'''), 37.0 (γ -CH₂), 34.2 (α -CH₂), 28.0 (C-2), 24.6 (β -CH₂). MS (EI+) (m/z): found 717.32732 [$\text{M}+\text{H}$]⁺, 739.30863 [$\text{M}+\text{Na}$]⁺; calculated 717.33350 [$\text{M}+\text{H}$]⁺, 739.31544 [$\text{M}+\text{Na}$]⁺.

2'''-N-[(4-methoxyphenyl)amino]carbonyl neomycin B x 5 HFBA (15a). The title

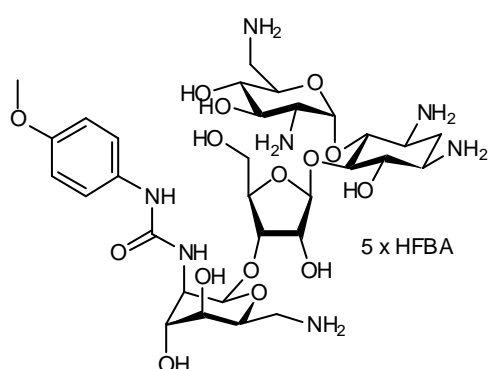

compound was prepared according to the general

procedure described above. Derivative **15a** was obtained as a white solid. For the measurement of regioselectivity and the characterization of the compound $^1\text{H-NMR}$ and HSQC spectra were recorded and ESI-MS was employed. The yield was calculated from $^1\text{H-NMR}$ - and HPLC peak integrals: $R_t = 15.0$ min, 44 % yield (apt1). TLC ($\text{CHCl}_3/\text{MeOH}/17\% \text{NH}_4\text{OH}$ 2:1:1 v/v/v) $R_f = 0.45$. $^1\text{H-NMR}$ (D_2O , 500 MHz) δ (p.p.m.) 7.23 (d, $J = 9$ Hz, 2H, Ar-H3, Ar-H5), 7.00 (d, $J = 9$ Hz, 2H, Ar-H2, Ar-H6), 6.05 (d, $J = 3.5$ Hz, 1H, 1-H'), 5.42 (d, $J = 1.5$ Hz, 1H, 1-H''), 5.11 (s, 1H, 1-H'''), 4.43 (t, $J = 5.25$ Hz, 1H, 3-H''), 4.33 (m, 1H, 2-H''), 4.26-4.19 (m, 2H, 5-H''', 4-H''), 4.12-4.07 (m, 2H, 4-H, 2-H'''), 4.04 (m, 1H, 3-H'''), 4.00 (t, $J = 14.5$ Hz, 1H, 5-H'), 3.95 – 3.88 (m, 3H, 5-H_a'', 5-H, 3-H'), 3.83 (s, 3H, OCH₃), 3.76-3.67 (m, 3H, 5-H_b'', 6-H,

4-H'''), 3.55 (dt, $J = 3$ Hz, $J = 9.5$ Hz, 1H, 3-H), 3.51-3.41 (m, 3H, 2-H', 4-H', 6-H_a'), 3.38-3.28 (m, 4H, 1-H, 6-H_a''', 6-H_b''', 6-H_b'), 2.50 (dt, $J = 11.5$ Hz; $J = 3$ Hz, 1H, 2-H_{eq}), 1.90 (dd, $J = 12.7$ Hz, 1H, 2-H_{ax}). APT (D₂O, 125.7 MHz) δ (p.p.m.) 158.47 (Carbonyl-C), 156.10 (Ar-C4), 130.32 (Ar-C1), 125.11 (2C, Ar-C2,C6), 114.93 (2C, Ar-C3,C5), 110.12 (C-1''), 98.72 (C-1'''), 95.64 (C-1'), 84.75 (C-5), 82.05 (C-4''), 75.82 (C-3''), 74.95 (C-4), 74.31 (C-2''), 72.79 (C-6), 70.61 (C-4'), 70.18 (C-5'''), 69.78 (C-3'''), 69.41 (C-3'), 68.07 (C-4'''), 67.93 (C-5'), 60.00 (C-5''), 55.58 (CH₃), 53.36 (C-2'), 51.13 (C-2'''), 49.75 (C-1), 48.42 (C-3), 40.61 (C-6'''), 39.95 (C-6'), 27.93 (C-2). MS (EI+) (m/z): found 764.36742 [M+H]⁺, 786.34508 [M+Na]⁺; calculated 764.36724 [M+H]⁺, 786.34918 [M+Na]⁺.

2'''-N-(phenylamino)carbonyl neomycin B x 5 HFBA (15b). The title compound was

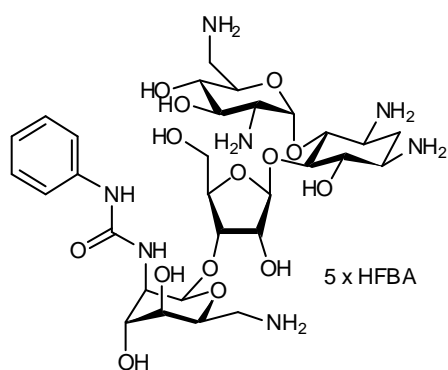

prepared according to the general procedure described above. Derivative **15b** was obtained as a white solid. For the measurement of regioselectivity and the characterization of the compound ¹H-NMR and HSQC spectra were recorded and ESI-MS was employed. The yield was calculated from ¹H-NMR- and HPLC peak integrals: R_t = 18.2 min, 51 % yield (apt1). TLC

(CHCl₃/MeOH/17% NH₄OH 2:1:1 v/v/v) R_f = 0.48. ¹H-NMR (D₂O, 500 MHz) ¹H-NMR (D₂O, 500 MHz) δ (p.p.m.) 7.38 (t, $J = 7.75$ Hz, 2H, Ar-H3, Ar-H5), 7.30 (d, $J = 8.0$ Hz, 2H, Ar-H2, Ar-H6), 7.18 (t, $J = 7.25$ Hz, 1H, Ar-H4), 6.03 (d, $J = 3.5$ Hz, 1H, 1-H'), 5.40 (s, 1H, 1-H''), 5.16 (s, 1H, 1-H'''), 4.43 (t, $J = 5.25$ Hz, 1H, 3-H'), 4.34 (m, 1H, 2-H''), 4.24 (t, $J = 4.5$ Hz, 1H, 5-H'''), 4.18 (m, 1H, 4-H''), 4.11-4.03 (m, 3H, 4-H, 2-H''', 3-H'''), 3.99 (t, $J = 10.00$ Hz, 1H, 5-H'), 3.95 – 3.85 (m, 3H, 5-H_a'', 5-H, 3-H'), 3.72-3.67 (m, 3H, 5-H_b'', 6-H, 4-H'''), 3.54 (dt, $J = 10$ Hz, $J = 3$ Hz, 1H, 3-H), 3.49-3.39 (m, 3H, 2-H', 4-H', 6-H_a'), 3.36-3.31 (m, 3H, 1-H, 6_a-H''', 6-H_b'''), 3.27 (dd, $J = 14$ Hz, $J = 7$ Hz, 1H, 6-H_b'), 2.49 (dt, $J = 12$ Hz; $J = 4$ Hz, 1H, 2-H_{eq}), 1.90 (dd, $J = 12.5$ Hz, 1H, 2-H_{ax}). ¹³C-signals based on HSQC spectrum (D₂O, 500 MHz) δ (p.p.m.) 129.5 (2C, Ar-C3,C5), 124.7 (Ar-C4), 121.9 (2C, Ar-C2,C6), 110.1 (C-1''), 98.6 (C-1'''), 95.3 (C-1'), 84.9 (C-5), 81.8 (C-4''), 75.6 (C-3''), 74.3 (C-4), 74.1 (C-2''), 72.4 (C-6), 70.8 (C-4'), 70.4 (C-5'''), 70.0 (C-3'''), 69.5 (C-3'), 68.2 (C-4'''), 68.1 (C-5'), 60.2 (C-5''), 53.5 (C-2'), 50.9 (C-2'''), 49.8 (C-1), 48.5 (C-3), 40.7 (C-6'''), 40.2 (C-6'), 27.9 (C-2); signals of quaternary carbons (CO, Ar-C1) are missing due to the fact that they are not detectable by HSQC spectroscopy. MS (EI+) (m/z): found 734.35551 [M+H]⁺, 756.33745 [M+Na]⁺; calculated 734.35668 [M+H]⁺, 756.33862 [M+Na]⁺.

2'''-N-[4-(N,N-dimethylamino)phenyl]carbonyl neomycin B x 6 HFBA (15c). The title

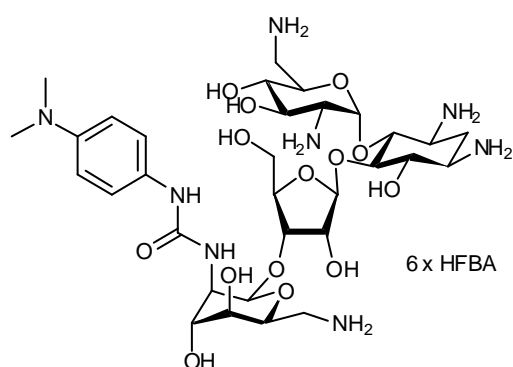

compound was prepared according to the general procedure described above. Derivative **15c** was obtained as a white solid. For the measurement of regioselectivity and the characterization of the compound $^1\text{H-NMR}$ and HSQC spectra were recorded and ESI-MS was employed. The yield was calculated from $^1\text{H-NMR}$ - and HPLC peak integrals:

$R_t = 16.9$ min, 48 % yield (apt1). TLC ($\text{CHCl}_3/\text{MeOH}/17\% \text{NH}_4\text{OH}$ 2:1:1 v/v/v) $R_f = 0.53$. $^1\text{H-NMR}$ (D_2O , 500 MHz) $^1\text{H-NMR}$ (D_2O , 500 MHz) δ (p.p.m.) 7.50 (m, 4H, Ar-H2, Ar-H3, Ar-H5, Ar-H6), 6.01 (d, $J = 3.5$ Hz, 1H, 1-H'), 5.39 (d, $J = 2$ Hz, 1H, 1-H''), 5.12 (d, $J = 1.5$ Hz, 1H, 1-H'''), 4.44 (t, $J = 5.0$ Hz, 1H, 3-H'), 4.36 (m, 1H, 2-H'), 4.25 (t, $J = 4.25$ Hz, 1H, 5-H'''), 4.14 (m, 1H, 4-H'), 4.11-4.08 (m, 3H, 4-H, 2-H''', 3-H'''), 3.99 (m, 1H, 5-H'), 3.92 – 3.87 (m, 3H, 5-H_a'', 5-H, 3-H'), 3.77 (s,br, 1H, 4-H'''), 3.73-3.66 (m, 2H, 5-H_b'', 6-H), 3.53 (td, $J = 11.5$ Hz, $J = 3.5$ Hz, 1H, 3-H), 3.48-3.42 (m, 3H, 2-H', 6-H_a', 4-H'), 3.41-3.31 (m, 3H, 6-H_a'', 6-H_b'', 1-H), 3.27 (dd, $J = 13.5$ Hz, $J = 6.5$ Hz, 1H, 6-H_b'), 3.24 (s, 6H, $\text{N}(\text{CH}_3)_2$), 2.48 (dt, $J = 12.5$ Hz; $J = 2.5$ Hz, 1H, 2-H_{eq}), 1.90 (dd, $J = 12.5$ Hz, 1H, 2-H_{ax}). ^{13}C -signals based on HSQC spectrum (D_2O , 500 MHz) δ (p.p.m.) 121.1, 121.2 (4C, Ar-C2,Ar-C3, Ar-C5,Ar-C6), 110.1 (C-1'), 98.3 (C-1'''), 95.4 (C-1'), 84.7 (C-5), 81.3 (C-4'), 75.4 (C-3''), 75.1 (C-4), 74.0 (C-2''), 72.3 (C-6), 70.4 (C-4'), 70.2 (C-5'''), 69.7 (C-3'''), 69.2 (C-3'), 68.0 (C-4'''), 67.8 (C-5'), 59.9 (C-5''), 53.3 (C-2'), 50.6 (C-2'''), 49.6 (C-1), 48.2 (C-3), 46.2 (2C, $\text{N}(\text{CH}_3)_2$), 40.4 (C-6'''), 39.9 (C-6'), 27.7 (C-2); signals of quaternary carbons (CO, Ar-C1, Ar-C4) are missing due to the fact that they are not detectable by HSQC spectroscopy. MS (EI+) (m/z): found 777.39821 $[\text{M}+\text{H}]^+$, 799.37998 $[\text{M}+\text{Na}]^+$; calculated 777.39887 $[\text{M}+\text{H}]^+$, 799.38082 $[\text{M}+\text{Na}]^+$.

2'''-N-[(4-methoxyphenyl)amino]carbonyl paromomycin x 4 HFBA (16). The title

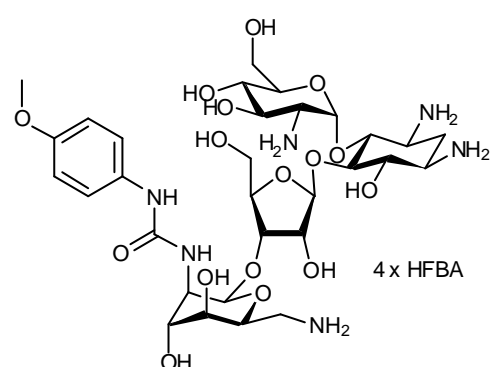

compound was prepared according to the general procedure described above. Derivative **16** was obtained as a white solid. For the measurement of regioselectivity and the characterization of the compound $^1\text{H-NMR}$ and HSQC spectra were recorded and ESI-MS was employed. The yield was calculated from $^1\text{H-NMR}$ - and HPLC peak integrals: $R_t = 7.4$

min, 49 % yield (apt1) TLC ($\text{CHCl}_3/\text{MeOH}/17\% \text{NH}_4\text{OH}$ 2:1:1 v/v/v) $R_f = 0.65$. $^1\text{H-NMR}$

(D₂O, 600 MHz) δ (p.p.m.) 7.24 (d, $J = 9$ Hz, 2H, Ar-H2), 7.01 (d, $J = 9$ Hz, 2H, Ar-H3), 5.81 (d, $J = 3.5$ Hz, 1H, 1-H'), 5.37 (d, $J = 1.5$ Hz, 1H, 1-H''), 5.12 (s, 1H, 1-H'''), 4.46 (t, $J = 5.5$ Hz, 1H, 3-H'), 4.33 (m, 1H, 2-H'), 4.23 (t, $J = 5.5$ Hz, 1H, 5-H''), 4.18 (m, 1H, 4-H'), 4.09-4.01 (m, 3H, 4-H, 2-H''', 3-H'''), 3.93-3.85 (m, 4H, 5-H_a'', 6-H_a', 3-H', 5-H), 3.83 (s, 3H, OCH₃), 3.80-3.68 (m, 4H, 5-H', 5-H_b'', 6-H_b', 4-H''), 3.71 (t, $J = 9.5$ Hz, 1H, 6-H), 3.56 (t, $J = 9.75$ Hz, 1H, 3-H), 3.51 (t, $J = 7.75$ Hz, 1H, 4-H'), 3.44 (dd, $J = 11.0$ Hz, $J = 4.0$ Hz, m, 1H, 2-H'), 3.38-3.30 (m, 3H, 6-H_a'', 6b-H_b'', 1-H), 2.50 (dt, $J = 13.0$ Hz; $J = 4.0$ Hz, 1H, 2-H_{eq}), 1.86 (dd, $J = 12.0$ Hz, 1H, 2-H_{ax}). ¹³C-signals based on HSQC (D₂O, 600 MHz) δ (p.p.m.) 125.3 (2C, Ar-C2, C6), 114.9 (2C, Ar-C3, C5), 110.1 (C-1'), 98.7 (C-1''), 96.2 (C-1'), 84.5 (C-5), 81.9 (C-4'), 77.4 (C-4), 75.7 (C-3'), 74.2 (C-2'), 74.1 (C-5'), 72.4 (C-6), 70.5 (C-5'''), 70.0 (C-3'''), 69.4 (C-4'), 69.0 (C-3'), 68.3 (C-4''), 60.4, 60.3 (2C, C-5'', C-6'), 55.8 (CH₃), 53.9 (C-2'), 51.1 (C-2'''), 49.8 (C-1), 49.1 (C-3), 40.8 (C-6'''), 28.2 (C-2); signals of quaternary carbons (CO, Ar-C1, Ar-C4) are missing due to the fact that they are not detectable by HSQC spectroscopy. MS (EI+) (m/z): found 765.35071 [M+H]⁺, 787.33215 [M+Na]⁺; calculated 765.35126 [M+H]⁺, 787.33320 [M+Na]⁺.

6'''-azido neomycin B x 5 HFBA (17). The title compound was prepared according to the

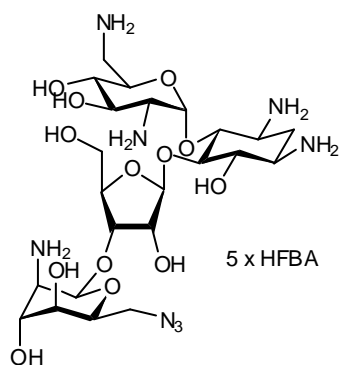

general procedure described above. Derivative **17** was obtained as a white solid. For the measurement of regioselectivity and the characterization of the compound ¹H-NMR and HSQC spectra were recorded and electrospray ionization (ESI)-MS was employed. The yield was calculated from ¹H-NMR- and HPLC peak integrals: $R_t = 13.0$ min, 46 % yield (apt1). ¹H-NMR (D₂O, 500 MHz) δ (p.p.m.) 6.00 (d, $J = 3.5$ Hz, 1H, 1-H'), 5.43 (s, 1H, 1-H''), 5.26 (s, 1H, 1-H'''), 4.49 (dd, $J = 7$ Hz, $J = 5$ Hz, 1H, 3-H'), 4.44 (d, $J = 4.5$ Hz, 1H, 2-H'), 4.26-4.20 (m, 3H, 3-H''', 4-H'', 5-H'''), 4.06 (t, $J = 9.5$ Hz, 1H, 4-H), 4.01-3.92 (m, 4H, 3-H', 5-H_a'', 5-H, 5-H'), 3.78-3.66 (m, 4H, 5-H_b'', 6-H_a'', 4-H''', 6-H), 3.52-3.36 (m, 2H, 2-H''', 3-H), 3.51-3.43 (m, 4H, 4-H', 6-H_a', 6-H_b'', 2-H'), 3.37 (dt, $J = 11.8$ Hz, $J = 4.5$ Hz, 1H, 1-H), 3.30 (dd, $J = 14$ Hz, $J = 6.5$ Hz, 1H, 6-H_b'), 2.50 (dt, $J = 12.5$ Hz, $J = 4.3$ Hz, 1H, 2-H_{eq}), 1.90 (dd, $J = 12.5$ Hz, 1H, 2-H_{ax}). ¹³C-signals based on HSQC (D₂O, 500 MHz) δ (p.p.m.) 110.2 (C-1'), 95.6 (C-1'), 95.2 (C-1'''), 84.6 (C-5), 81.4 (C-4'), 75.3 (C-4), 75.1 (C-3'), 73.7 (C-5'''), 73.4 (C-2'), 72.5 (C-6), 70.5 (C-4'), 69.3 (C-3'), 67.9 (C-5'), 67.7 (C-3'''), 66.5 (C-4''), 60.2 (C-5''), 53.4 (C-2'), 50.9 (C-6'''), 50.8 (C-2'''), 49.6 (C-1), 48.2 (C-3), 39.9 (C-6'), 27.9 (C-2). MS (EI+) (m/z): found 641.30845 [M+H]⁺, 663.28839 [M+Na]⁺; calculated 641.31006 [M+H]⁺, 663.29200 [M+Na]⁺.

3''',6'''-di-azido neomycin B x 4 HFBA (18). The title compound was prepared according to

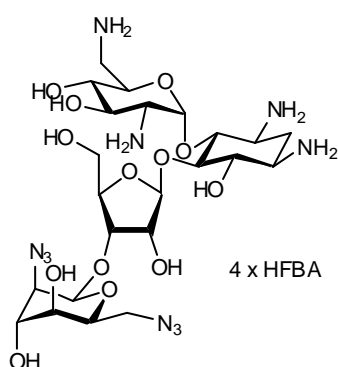

the general procedure described above. Derivative **18** was obtained as a white solid. For the measurement of regioselectivity and the characterization of the compound ¹H-NMR and HSQC spectra were recorded and electro spray ionization (ESI)-MS was employed. The yield was calculated from ¹H-NMR- and HPLC peak integrals: R_t = 8.9 min, 16 % yield (apt1). ¹H-NMR (D₂O, 500 MHz) δ (p.p.m.) 6.04 (d, J = 3 Hz, 1H, 1-H'), 5.47 (s, 1H, 1-

H''), 5.17 (d, J = 1 Hz, 1H, 1-H''), 4.49 (dd, J = 5.5 Hz, J = 4 Hz, 1H, 3-H'), 4.45 (dd, J = 4 Hz, J = 2 Hz, 1H, 2-H'), 4.28 (dt, J = 5.3 Hz, J = 2 Hz, 1H, 4-H'), 4.16-4.13 (m, 2H, 3-H'', 5-H''), 4.08 (t, J = 8.3 Hz, 1H, 4-H), 4.03-3.94 (m, 4H, 5-H', 3-H', 5-H_a'', 5-H), 3.90 (m, 1H, 2-H''), 3.78 (dd, J = 10.5 Hz, J = 4.5 Hz, 1H, 5-H_b'), 3.72-3.67 (m, 2H, 6-H_a'', 6-H), 3.62 (m, 1H, 4-H''), 3.56 (dt, J = 9.3 Hz, J = 3.5 Hz, 1H, 3-H), 3.53-3.44 (m, 4H, 6-H_a', 6-H_b'', 2-H', 4-H'), 3.39 (dt, J = 9.5 Hz, J = 3.5 Hz, 1H, 1-H), 3.32 (dd, J = 11.5 Hz, J = 5 Hz, 1H, 6-H_b'), 2.52 (dt, J = 10.5 Hz, J = 3.5 Hz, 1H, 2-H_{eq}), 1.92 (dd, J = 10.5 Hz, 1H, 2-H_{ax}). ¹³C-signals based on HSQC (D₂O, 500 MHz) δ (p.p.m.) 110.2 (C-1'), 98.1 (C-1''), 95.7 (C-1'), 84.6 (C-5), 81.5 (C-4'), 75.3 (C-4), 74.7 (C-3'), 74.3 (C-5''), 73.2 (C-2''), 72.4 (C-6), 70.3 (C-4'), 69.2 (C-3''), 69.0 (C-3'), 67.8 (C-5'), 67.2 (C-4''), 60.3 (C-5'), 59.6 (C-2''), 53.2 (C-2'), 50.8 (C-6''), 49.8 (C-1), 48.2 (C-3), 39.8 (C-6'), 28.1 (C-2). MS (EI+) (m/z): found 667.29664 [M+H]⁺, 689.27895 [M+Na]⁺; calculated 667.30056 [M+H]⁺, 689.28250 [M+Na]⁺.

2'''-N-(propylamino)carbonyl neomycin B x 5 HFBA (19a). The title compound was

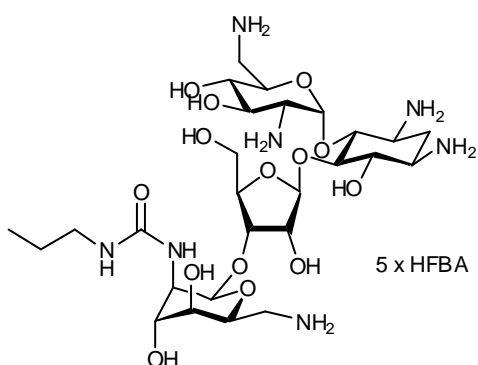

prepared according to the general procedure described above. Derivative **19a** was obtained as a white solid. For the measurement of regioselectivity and the characterization of the compound ¹H-NMR and HSQC spectra were recorded and electro spray ionization (ESI)-MS was employed. The yield was calculated from ¹H-NMR- and HPLC peak integrals: R_t = 11.6

min, 21 % yield (apt1). ¹H-NMR (D₂O, 500 MHz) δ (p.p.m.) 6.03 (d, J = 4 Hz, 1H, 1-H'), 5.40 (s, 1H, 1-H'), 5.07 (s, 1H, 1-H''), 4.40 (t, J = 5.5 Hz, 1H, 3-H'), 4.32 (dd, J = 4 Hz, J = 2 Hz, 1H, 2-H'), 4.22 (t, J = 4.3 Hz, 1H, 5-H''), 4.15 (dt, J = 6.8 Hz, J = 3 Hz, 1H, 4-H'), 4.08 (t, J = 9.8 Hz, 1H, 4-H), 4.01-3.97 (m, 3H, 5-H', 3-H'', 2-H''), 3.95-3.88 (m, 3H, 3-H', 5-H, 5-H_a''), 3.74-3.67 (m, 3H, 4-H'', 5-H_b'', 6-H), 3.54 (dt, J = 11 Hz, J = 3.5 Hz, 1H, 3-H),

3.49-3.41 (m, 3H, 4-H', 6-H_a', 2-H'), 3.39-3.22 (m, 3H, 6-H_a'', 6-H_b'', 1-H), 3.29 (dd, J = 13.5 Hz, J = 6.5 Hz, 1H, 6-H_b'), 3.04 (q, J = 6.6 Hz, 2H, α-CH₂), 2.49 (dt, J = 12.5 Hz, J = 3.8 Hz, 1H, 2-H_{eq}), 1.89 (dd, J = 12.5 Hz, 1H, 2-H_{ax}), 1.45 (q, J = 7.2 Hz, 2H, β-CH₂), 0.85 (t, J = 7.3 Hz, 3H, CH₃). ¹³C-signals based on HSQC (D₂O, 500 MHz) δ (p.p.m.) 110.0 (C-1'), 98.8 (C-1''), 95.4 (C-1'), 84.8 (C-5), 81.7 (C-4'), 75.8 (C-3'), 75.1 (C-4), 74.1 (C-2'), 72.5 (C-6), 70.5 (C-4'), 70.3 (C-5''), 70.0 (C-3''), 69.4 (C-3'), 68.1 (C-4''), 68.0 (C-5'), 60.1 (C-5'), 53.4 (C-2'), 50.9 (C-2''), 49.6 (C-1), 48.3 (C-3), 41.6 (α-CH₂), 40.5 (C-6''), 39.9 (C-6'), 27.9 (C-2), 22.4 (β-CH₂), 10.3 (CH₃); signal of quaternary carbon (CO) is missing due to the fact that it is not detectable by HSQC spectroscopy. MS (EI+) (*m/z*): found 700.36911 [M+H]⁺, 722.34964 [M+Na]⁺; calculated 700.37233 [M+H]⁺, 722.35427 [M+Na]⁺.

2'''-N-(isopropylamino)carbonyl neomycin B x 5 HFBA (19b). The title compound was

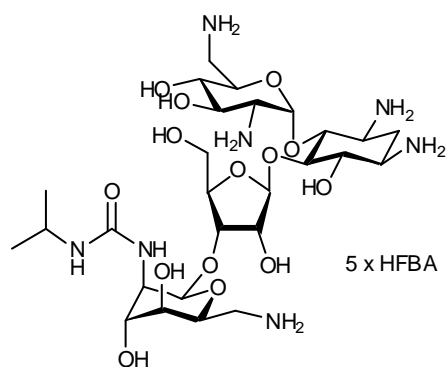

prepared according to the general procedure described above. Derivative **19b** was obtained as a white solid. For the measurement of regioselectivity and the characterization of the compound ¹H-NMR and HSQC spectra were recorded and electro spray ionization (ESI)-MS was employed. The yield was calculated from ¹H-NMR- and HPLC peak integrals: R_t = 12.1 min, 32 %

yield (apt1). ¹H-NMR (D₂O, 500 MHz) δ (p.p.m.) 6.03 (d, J = 3.5 Hz, 1H, 1-H'), 5.40 (s, 1H, 1-H''), 5.06 (s, 1H, 1-H'''), 4.41 (t, J = 5.3 Hz, 1H 3-H'), 4.33 (dd, J = 5 Hz, J = 2.5 Hz, 1H, 2-H'), 4.22 (t, J = 5.3 Hz, 1H, 5-H''), 4.15 (t, J = 5 Hz, 1H, 4-H'), 4.09 (t, J = 9.8 Hz, 1H, 4-H), 4.02-3.98 (m, 3H, 5-H', 3-H'', 2-H''), 3.95-3.89 (m, 3H, 3-H', 5-H, 5-H_a'), 3.75-3.66 (m, 4H, 4-H'', 6-H, 5-H_b'', CH(CH₃)₂), 3.55 (dt, J = 11.3 Hz, J = 4 Hz, 1H, 3-H), 3.50-3.42 (m, 3H, 4-H', 6-H_a', 2-H'), 3.37-3.33 (m, 3H, 6-H_a'', 6-H_b'', 1-H), 3.29 (dd, J = 13.5 Hz, J = 6 Hz, 1H, 6-H_b'), 2.50 (dt, J = 12 Hz, J = 3.5 Hz, 1H, 2-H_{eq}), 1.90 (dd, J = 12 Hz, 1H, 2-H_{ax}), 1.09 (d, J = 6.5 Hz, 6H, CH₃). ¹³C-signals based on HSQC (D₂O, 500 MHz) δ (p.p.m.) 110.0 (C-1'), 98.72 (C-1''), 95.4 (C-1'), 84.9 (C-5), 81.8 (C-4'), 75.7 (C-3'), 75.1 (C-4), 74.2 (C-2'), 72.4 (C-6), 70.6 (C-4'), 70.3 (C-5''), 70.0 (C-3''), 69.4 (C-3'), 68.1 (C-4''), 68.0 (C-5'), 60.1 (C-5'), 53.4 (C-2'), 50.9 (C-2''), 49.7 (C-1), 48.4 (C-3), 42.2 (CH(CH₃)₂), 40.6 (C-6''), 40.0 (C-6'), 27.9 (C-2), 22.0 (2C, CH(CH₃)₂); signal of quaternary carbon (CO) is missing due to the fact that it is not detectable by HSQC spectroscopy. MS (EI+) (*m/z*): found 700.36917 [M+H]⁺, 722.34977 [M+Na]⁺; calculated 700.37233 [M+H]⁺, 722.35427 [M+Na]⁺.

2'''-N-(tert-butylamino)carbonyl neomycin B x 5 HFBA (19c). The title compound was

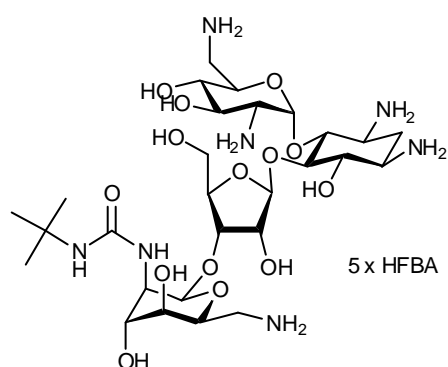

prepared according to the general procedure described above. Derivative **19c** was obtained as a white solid. For the measurement of regioselectivity and the characterization of the compound $^1\text{H-NMR}$ and HSQC spectra were recorded and electro spray ionization (ESI)-MS was employed. The yield was calculated from $^1\text{H-NMR}$ - and HPLC peak integrals: $R_t = 13.2$ min, 38 %

yield (apt1). $^1\text{H-NMR}$ (D_2O , 500 MHz) δ (p.p.m.) 5.98 (d, $J = 4$ Hz, 1H, 1- H'), 5.38 (s, 1H, 1- H''), 4.91 (d, $J = 2.5$ Hz, 1H, 1- H'''), 4.35 (m, 2H, 2- H'' , 3- H''), 4.22-4.16 (m, 2H, 4- H'' , 5- H''), 4.03 (t, $J = 9.8$ Hz, 1H, 4-H), 3.97-3.92 (m, 3H, 5- H' , 2- H''' , 3- H'''), 3.92-3.87 (m, 3H, 3- H' , 5-H, 5- H_a'), 3.70-3.56 (m, 3H, 6-H, 5- H_b'' , 4- H'''), 3.53 (dt, $J = 11.3$ Hz, $J = 4$ Hz, 1H, 3-H), 3.47-3.37 (m, 3H, 4- H' , 6- H_a' , 2- H'), 3.35-3.30 (m, 3H, 6- H_a''' , 6- H_b''' , 1-H), 3.26 (dd, $J = 15$ Hz, $J = 5.5$ Hz, 1H, 6- H_b'), 2.48 (dt, $J = 12.5$ Hz, $J = 3$ Hz, 1H, 2- H_{eq}), 1.88 (dd, $J = 11.5$ Hz, 1H, 2- H_{ax}), 1.16 (s, 9H, CH_3). ^{13}C -signals based on HSQC (D_2O , 500 MHz) δ (p.p.m.) 110.9 (C-1'), 97.91 (C-1'''), 95.7 (C-1'), 85.0 (C-5), 81.4 (C-4'), 74.3 (C-3'), 74.0 (C-4), 73.7 (2C, C-2'', C-5'''), 72.4 (C-6), 70.4 (C-4'), 70.4 (C-3'''), 69.4 (C-3'), 68.1 (C-5'), 68.7 (C-4'''), 60.8 (C-5''), 53.4 (C-2'), 51.4 (C-2'''), 49.7 (C-1), 48.4 (C-3), 40.4 (C-6'), 40.0 (C-6'''), 27.9 (C-2), 24.3 (3C, CH_3); signals of quaternary carbons (CO, $\text{C}(\text{CH}_3)_3$) are missing due to the fact that they are not detectable by HSQC spectroscopy. MS (EI+) (m/z): found 714.38522 $[\text{M}+\text{H}]^+$, 736.36821 $[\text{M}+\text{Na}]^+$; calculated 714.38798 $[\text{M}+\text{H}]^+$, 736.36992 $[\text{M}+\text{Na}]^+$.

2''',6'''-bis-N-(propylamino)carbonyl neomycin B x 4 HFBA (20a). The title compound

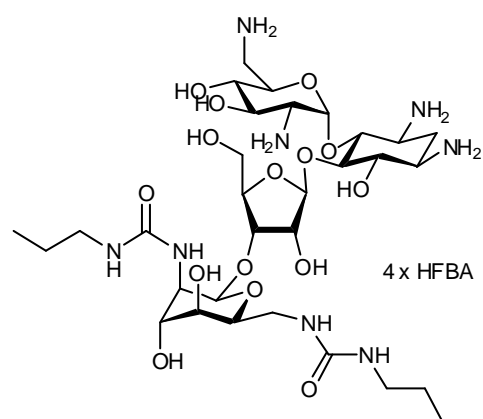

was prepared according to the general procedure described above. Derivative **20a** was obtained as a white solid. For the measurement of regioselectivity and the characterization of the compound $^1\text{H-NMR}$ and HSQC spectra were recorded and electro spray ionization (ESI)-MS was employed. The yield was calculated from $^1\text{H-NMR}$ - and HPLC peak integrals: $R_t = 9.6$ min, 31 % yield (apt1). $^1\text{H-NMR}$ (D_2O , 500

MHz) δ (p.p.m.) 6.05 (d, $J = 4$ Hz, 1H, 1- H'), 5.39 (s, 1H, 1- H''), 4.98 (s, 1H, 1- H'''), 4.37-4.32 (m, 2H, 3- H'' , 2- H''), 4.16 (dt, $J = 5.5$ Hz, $J = 2.5$ Hz, 1H, 4- H''), 4.09 (t, $J = 9.8$ Hz, 1H, 4-H), 4.02-3.98 (m, 3H, 3- H''' , 5- H' , 5- H'''), 3.96-3.89 (m, 4H, 2- H''' , 5-H, 3- H' , 5-

H_a''), 3.73-3.68 (m, 2H, 5-H_b'', 6-H), 3.65 (m, 1H, 4-H'''), 3.56 (dt, J = 11.3 Hz, 3.5 Hz, 1H, 3-H), 3.50 (t, J = 9.5 Hz, 1H, 4-H'), 3.48-3.35 (m, 5H, 6-H_a', 2-H', 6-H_a''', 6-H_b''', 1-H), 3.31 (dd, J = 14 Hz, J = 6.5 Hz, 1H, 6-H_b'), 3.06 (2xq, J = 6.5 Hz, 4H, α-CH₂), 2.50 (dt, J = 12 Hz, J = 3.8 Hz, 1H, 2-H_{eq}), 1.90 (dd, J = 12.5 Hz, 1H, 2-H_{ax}), 1.47 (2xq, J = 7 Hz, 4H, β-CH₂), 0.87 (2xt, J = 7.5 Hz, 6H, CH₃). ¹³C-signals based on HSQC (D₂O, 500 MHz) δ (p.p.m.) 110.2 (C-1''), 99.3 (C-1'''), 95.8 (C-1'), 85.0 (C-5), 82.2 (C-4''), 76.1 (C-3''), 75.4 (C-4), 74.4 (C-2''), 73.6 (C-5'''), 72.7 (C-6), 70.7 (C-4'), 70.3 (C-3'''), 69.5 (C-3'), 68.2 (C-5'), 67.1 (C-4'''), 60.5 (C-5'), 53.7 (C-2'), 51.4 (C-2'''), 50.0 (C-1), 48.6 (C-3), 41.9 (2C, α-CH₂), 40.2 (C-6'), 40.0 (C-6'''), 28.0 (C-2), 22.6 (2C, β-CH₂), 10.6 (2C, CH₃); signals of quaternary carbons (2x CO) are missing due to the fact that they are not detectable by HSQC spectroscopy. MS (EI+) (*m/z*): found 785.42184 [M+H]⁺, 807.40231 [M+Na]⁺; calculated 807.40703 [M+H]⁺, 679.31207 [M+Na]⁺.

2''',6'''-bis-*N*-(isopropylamino)carbonyl neomycin B x 4 HFBA (20b). The title

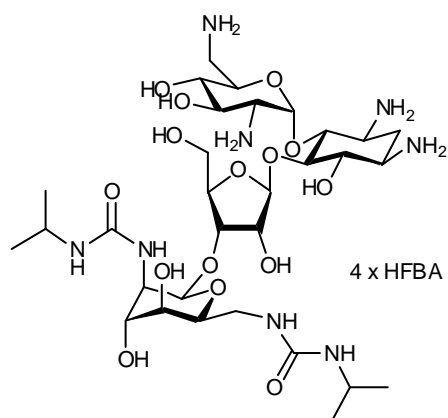

compound was prepared according to the general procedure described above. Derivative **20b** was obtained as a white solid. For the measurement of regioselectivity and the characterization of the compound ¹H-NMR and HSQC spectra were recorded and electro spray ionization (ESI)-MS was employed. The yield was calculated from ¹H-NMR- and HPLC peak integrals: R_t = 9.8 min, 17 % yield (apt1). ¹H-NMR (D₂O, 500 MHz) δ (p.p.m.) 6.04

(d, J = 3 Hz, 1H, 1-H'), 5.39 (s, 1H, 1-H''), 4.98 (s, 1H, 1-H'''), 4.35 (t, J = 5 Hz, 1H, 3-H'), 4.33 (dd, J = 4.5 Hz, J = 2.5 Hz, 1H, 2-H'), 4.15 (dt, J = 5.5 Hz, J = 3 Hz, 1H, 4-H'), 4.08 (t, J = 9.5 Hz, 1H, 4-H), 4.01-3.97 (m, 3H, 3-H''', 5-H', 5-H'''), 3.95-3.89 (m, 4H, 2-H''', 3-H', 5-H, 5-H_a''), 3.73-3.67 (m, 4H, CH(CH₃)₂, 5-H_b'', 6-H), 3.64 (m, 1H, 4-H'''), 3.55 (dt, J = 11.5 Hz, J = 4 Hz, 1H, 3-H), 3.49 (t, J = 9.5 Hz, 1H, 4-H'), 3.47-3.43 (m, 2H, 6-H_a', 2-H'), 3.40-3.34 (m, 3H, 6-H_a''', 6-H_b''', 1-H), 3.30 (dd, J = 13.5 Hz, J = 6.5 Hz, 1H, 6-H_b'), 2.50 (dt, J = 12.5 Hz, J = 3.5 Hz, 1H, 2-H_{eq}), 1.90 (dd, J = 12.5 Hz, 1H, 2-H_{ax}), 1.11 (2xd, J = 6.5 Hz, 12H, CH(CH₃)₂). ¹³C-signals based on HSQC (D₂O, 500 MHz) δ (p.p.m.) 109.9 (C-1''), 98.8 (C-1'''), 95.4 (C-1'), 84.6 (C-5), 81.8 (C-4''), 75.7 (C-3''), 75.0 (C-4), 74.0 (C-2''), 73.1 (C-5'''), 72.2 (C-6), 70.4 (C-4'), 69.9 (C-3'''), 69.2 (C-3'), 67.8 (C-5'), 66.7 (C-4'''), 60.1 (C-5'), 53.3 (C-2'), 51.0 (C-2'''), 49.6 (C-1), 48.2 (C-3), 42.0 (2C, CH(CH₃)₂), 39.8 (C-6'), 39.5 (C-6'''), 27.9 (C-2), 21.9 (4C, CH(CH₃)₂); signals of quaternary carbons (2x CO) are missing due to the fact that they are not detectable by HSQC spectroscopy. MS (EI+) (*m/z*):

found 785.42180 $[M+H]^+$, 807.40221 $[M+Na]^+$; calculated 807.40703 $[M+H]^+$, 679.31207 $[M+Na]^+$.

4.4.4 NMR-Spectra of Neomycin B & Synthesized Antibiotic Derivatives

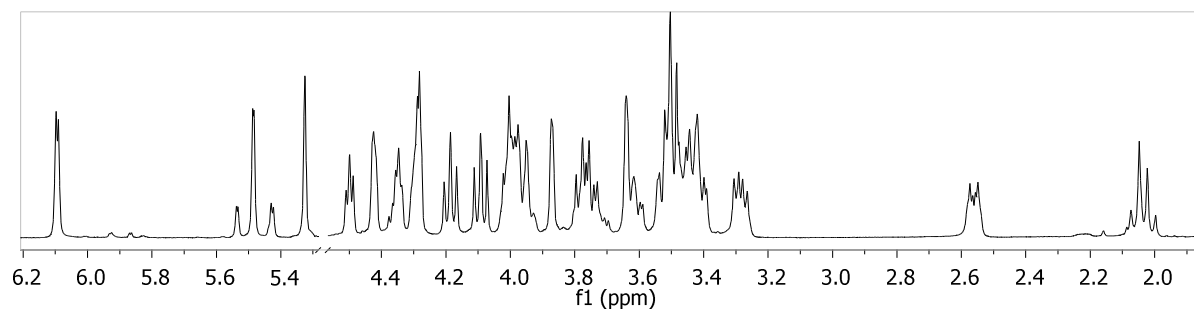

Figure 4.10a: $^1\text{H-NMR}$ (500 MHz, D_2O) spectrum of neomycin B x 6 HFBA 1.

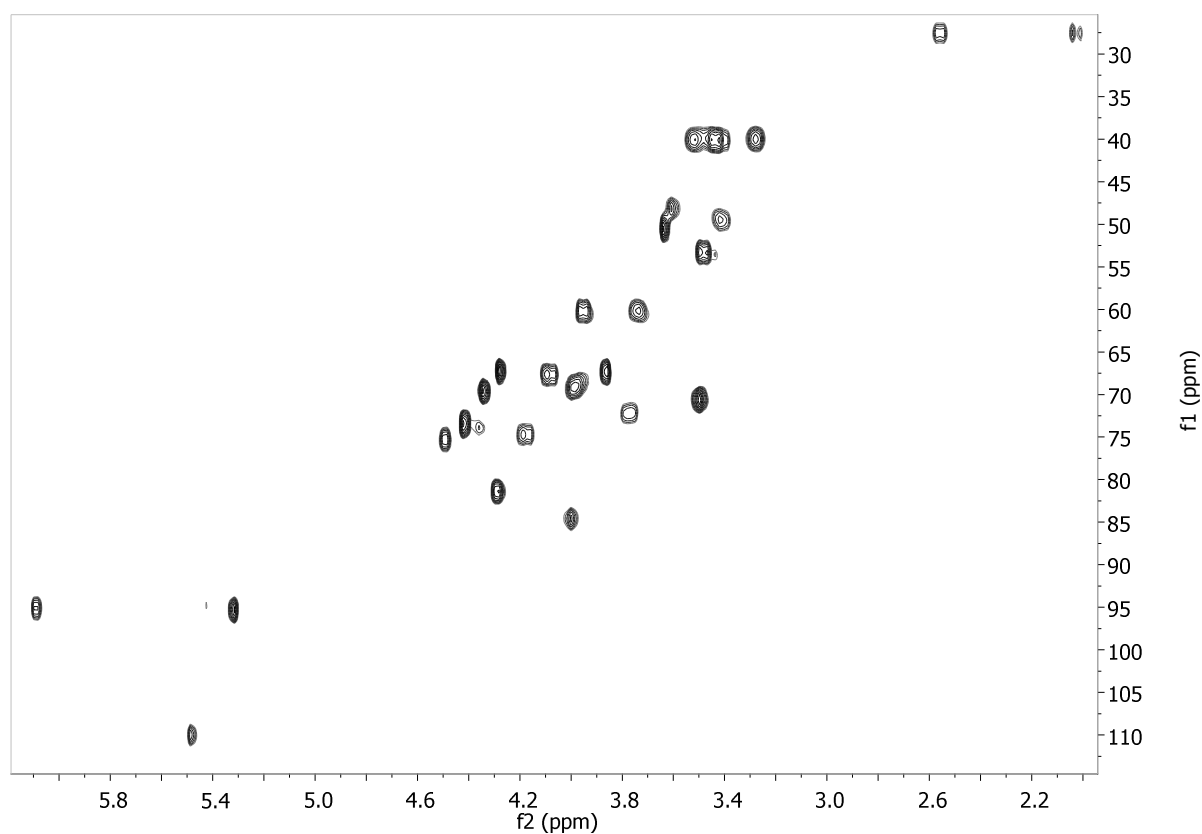

Figure 4.10b: HSQC (500 MHz, D_2O) spectrum of neomycin B x 6 HFBA 1

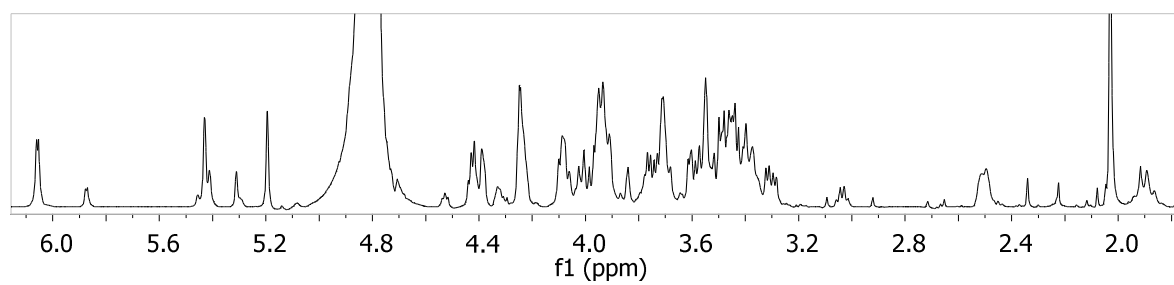

Figure 4.11a: $^1\text{H-NMR}$ (500 MHz, D_2O) spectrum of 6'''-*N*-acetyl neomycin B x 5 HFBA **10**.

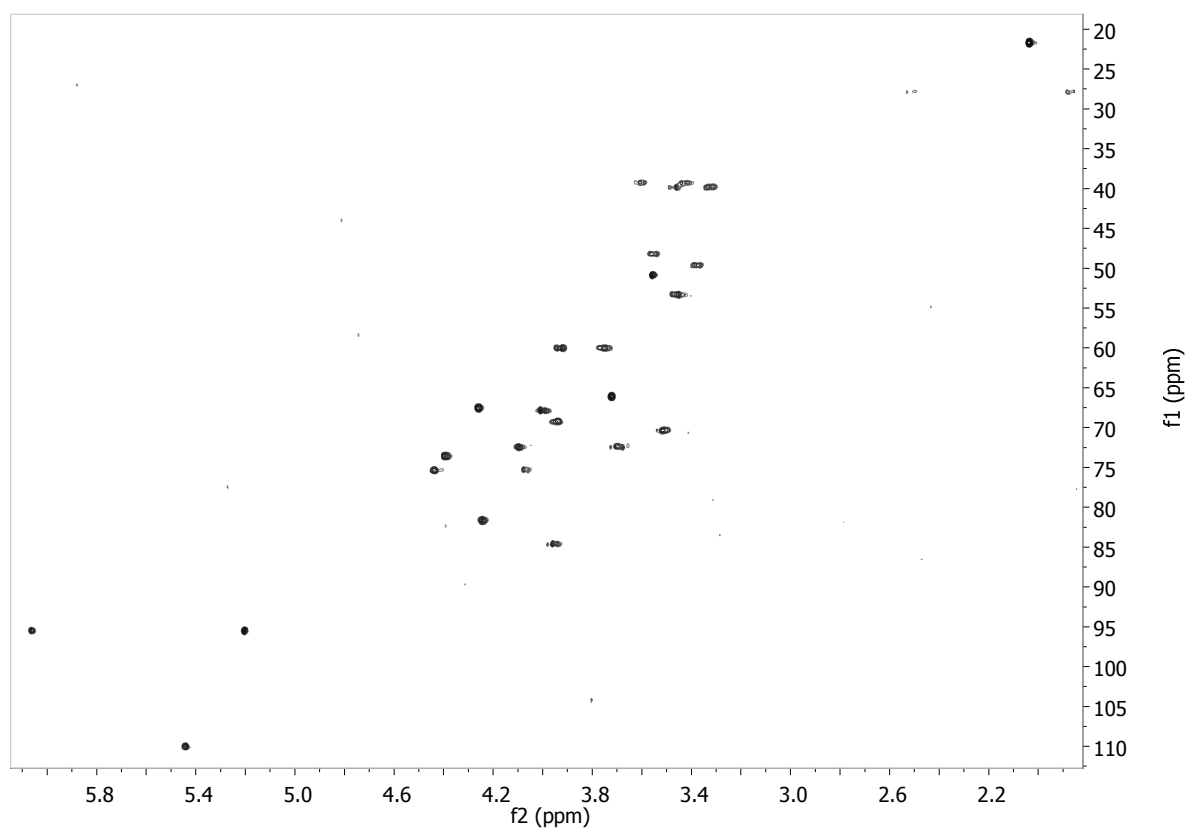

Figure 4.11b: HSQC (500 MHz, D_2O) spectrum of 6'''-*N*-acetyl neomycin B x 5 HFBA **10**.

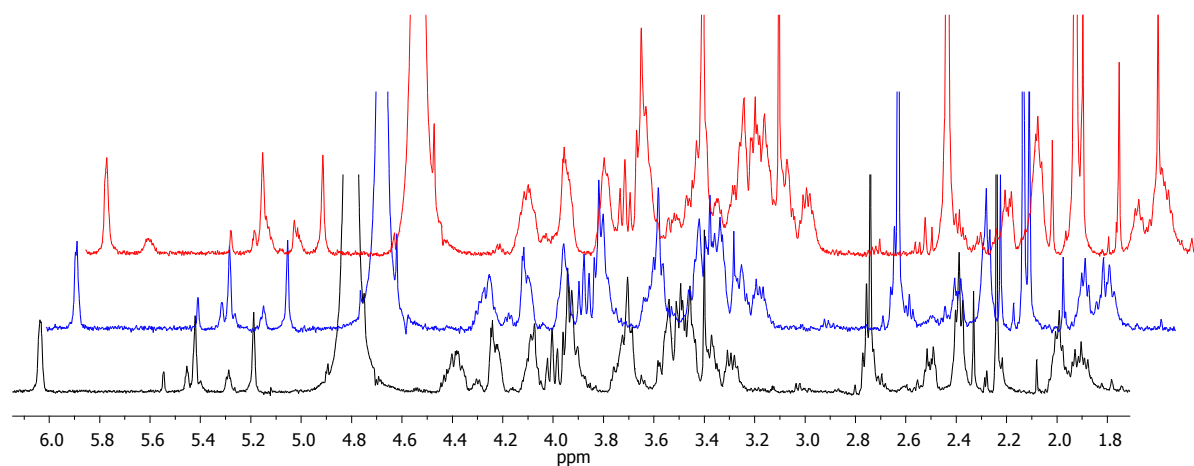

Figure 4.12a: ¹H-NMR (500 MHz, D₂O) spectrum of 6'''-N-γ-sulphydryl-propionyl neomycin B x 5 HFBA **14** using 30 (red), 15 (blue) and 5 (black) equiv. *Traut's* reagent **6** for the transformation of neomycin B.

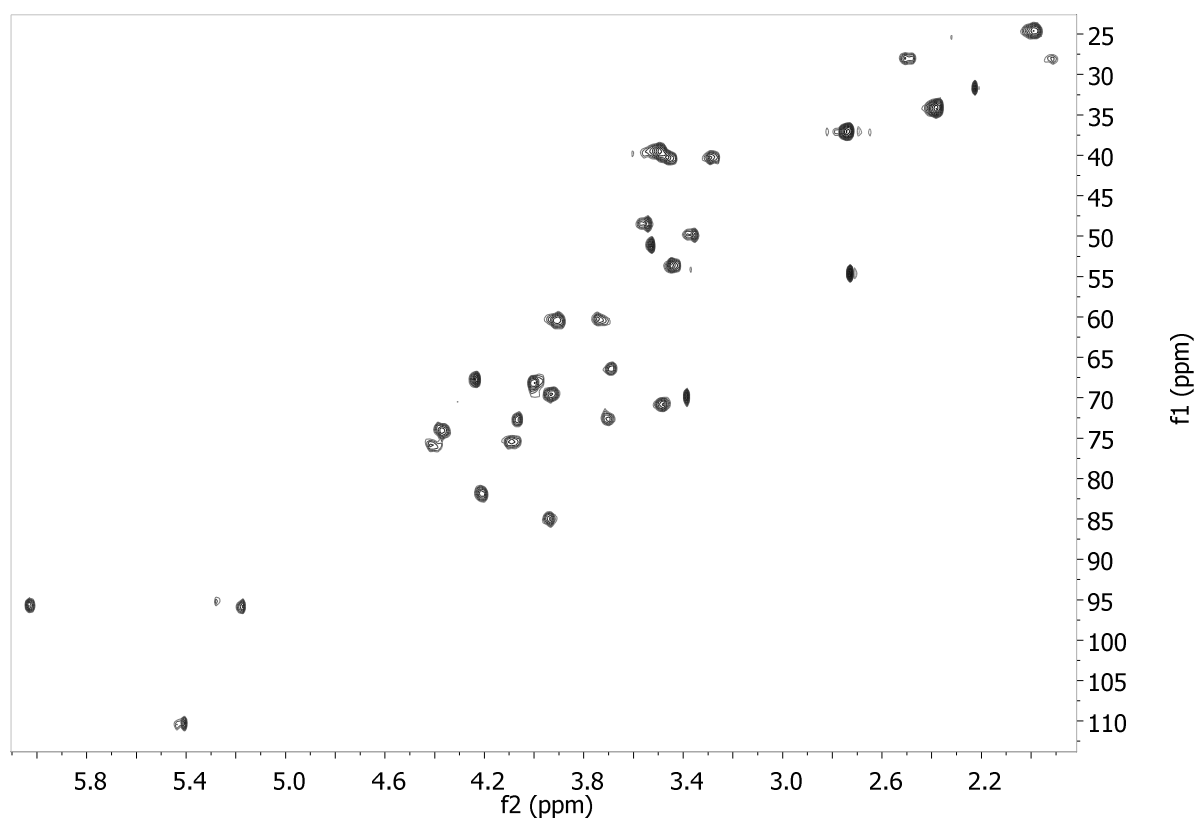

Figure 4.12b: HSQC (500 MHz, D₂O) spectrum of 6'''-N-γ-sulphydryl-propionyl neomycin B x 5 HFBA **14**.

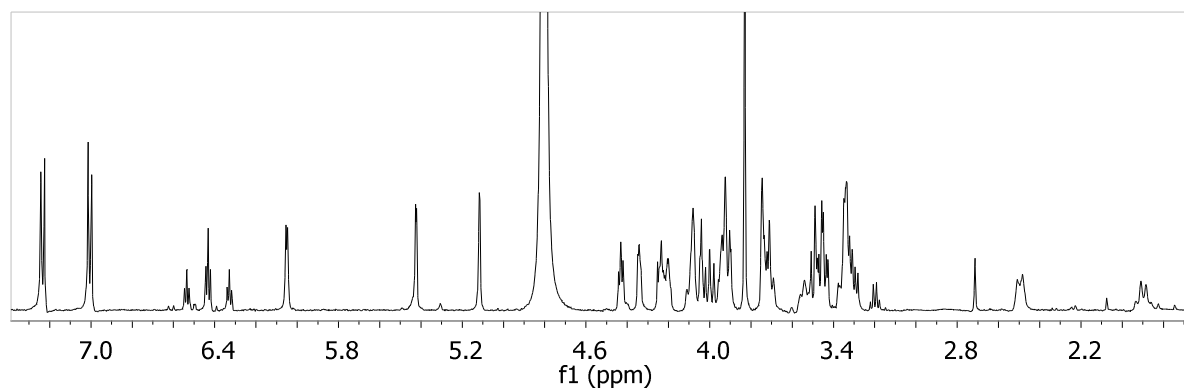

Figure 4.13a: $^1\text{H-NMR}$ (500 MHz, D_2O) spectrum of 2'''-N-[(4-methoxyphenyl)amino]carbonyl neomycin B x 5 HFBA **15a**.

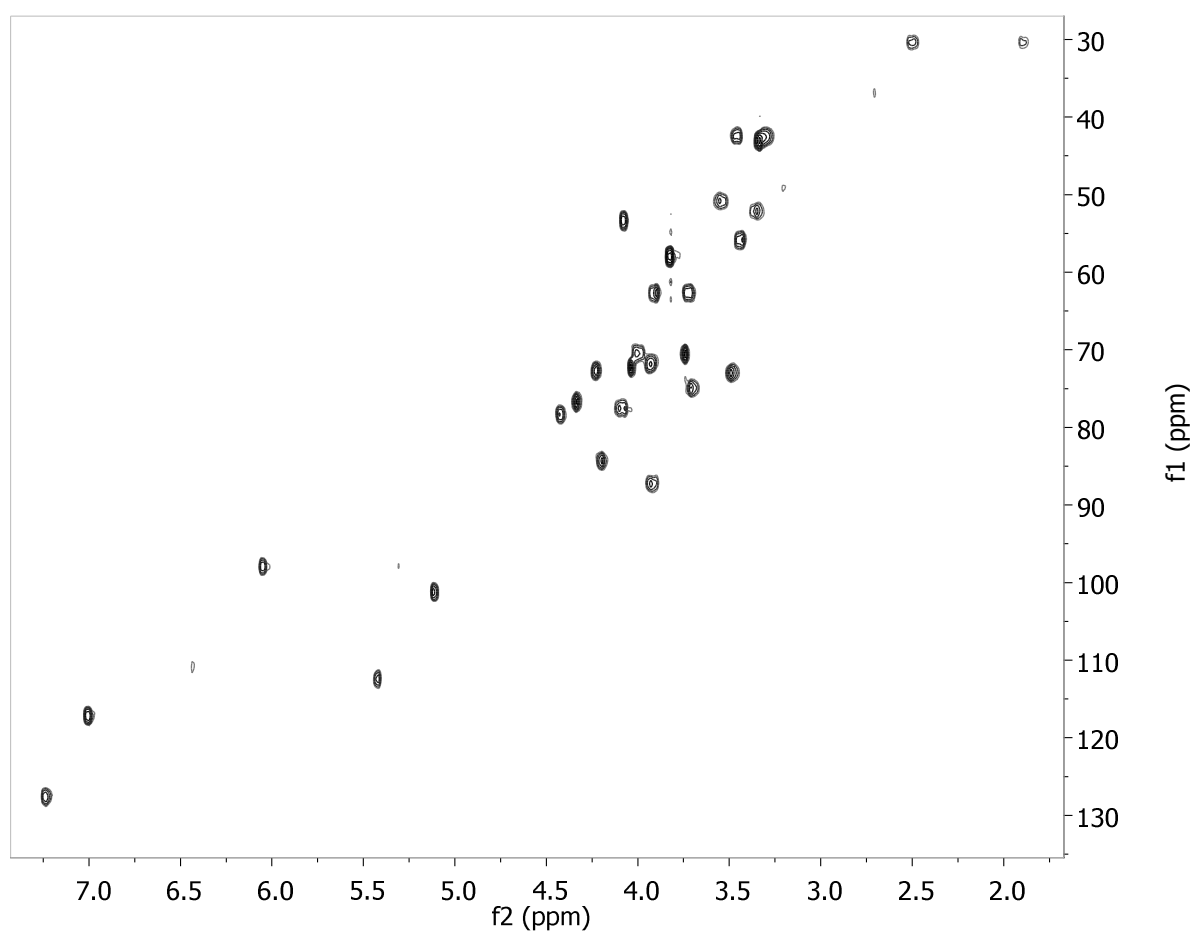

Figure 4.13b: HSQC (500 MHz, D_2O) spectrum of 2'''-N-[(4-methoxyphenyl)amino]carbonyl neomycin B x 5 HFBA **15a**.

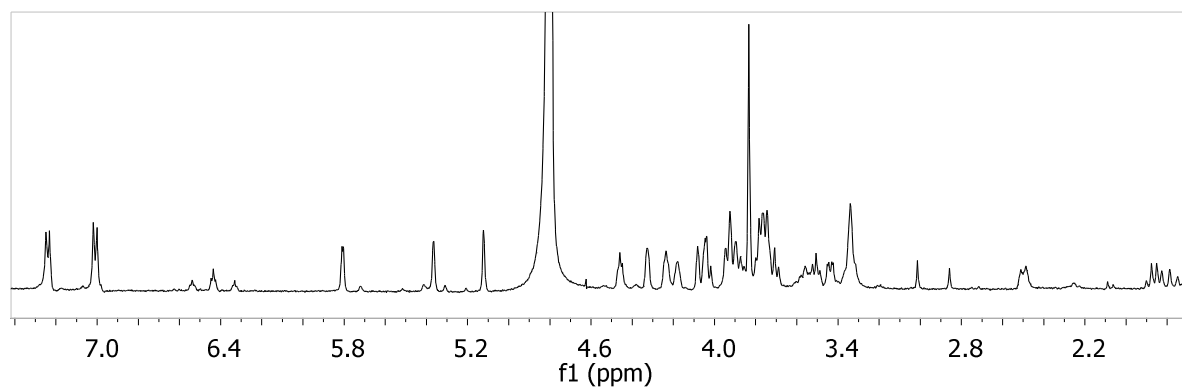

Figure 4.14a: $^1\text{H-NMR}$ (600 MHz, D_2O) spectrum of 2'''-N-[(4-methoxyphenyl)amino]carbonyl paromomycin x 4 HFBA **16**.

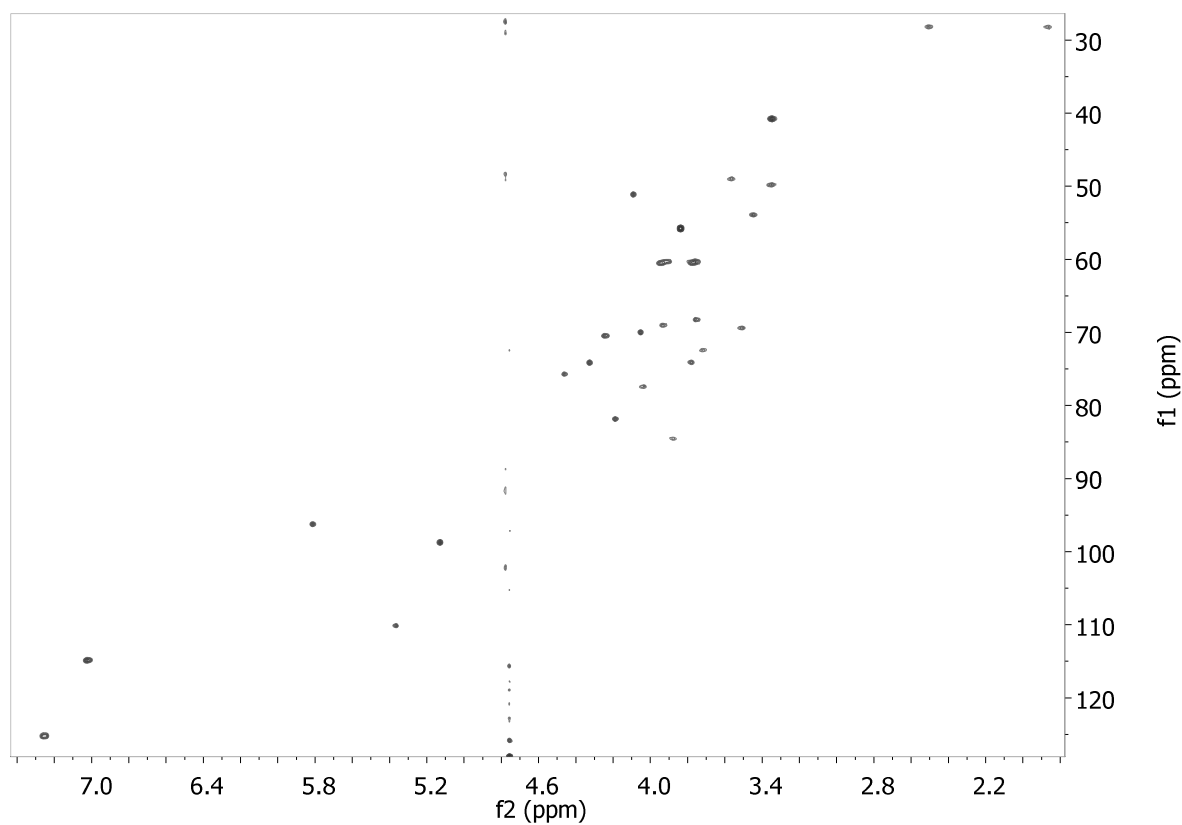

Figure 4.14b: HSQC (600 MHz, D_2O) spectrum of 2'''-N-[(4-methoxyphenyl)amino]carbonyl paromomycin x 4 HFBA **16**.

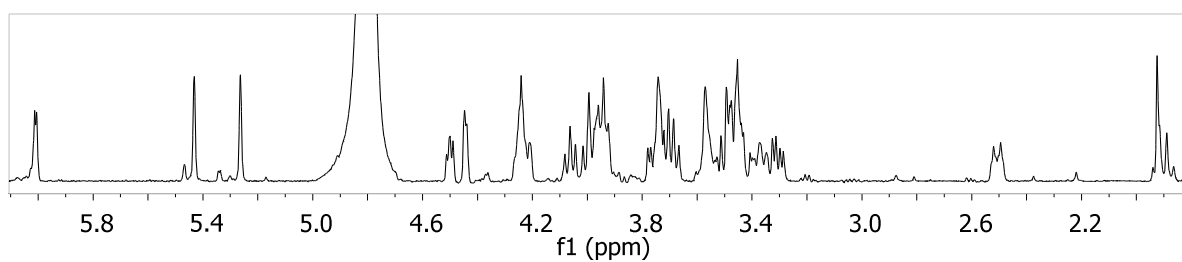

Figure 4.15a: $^1\text{H-NMR}$ (500 MHz, D_2O) spectrum of 6'''-azido neomycin B x 5 HFBA 17.

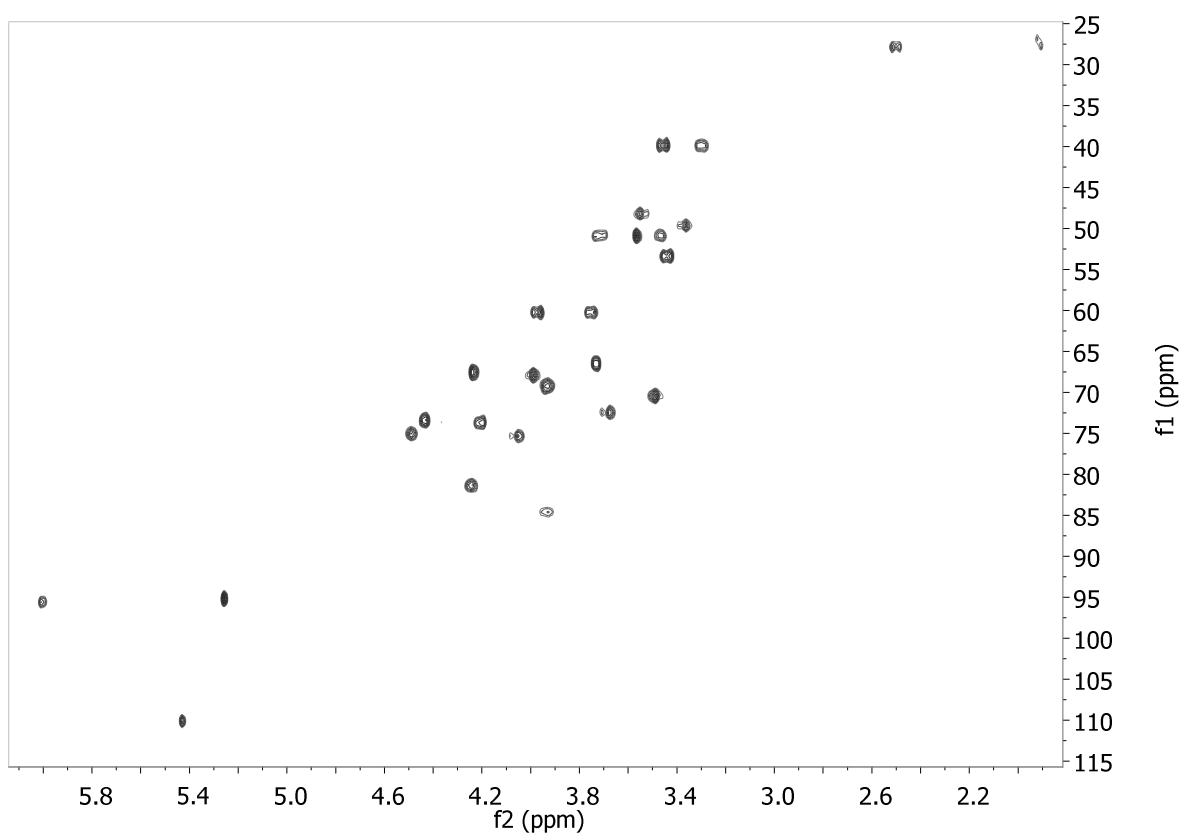

Figure 4.15b: HSQC (500 MHz, D_2O) spectrum of 6'''-azido neomycin B x 5 HFBA 17.

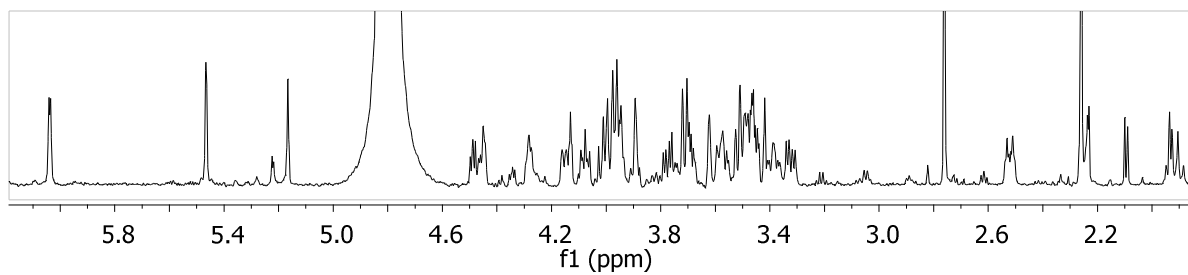

Figure 4.16a: HSQC (500 MHz, D₂O) spectrum of 2''', 6'''-di-azido neomycin B x 5 HFBA **18**.

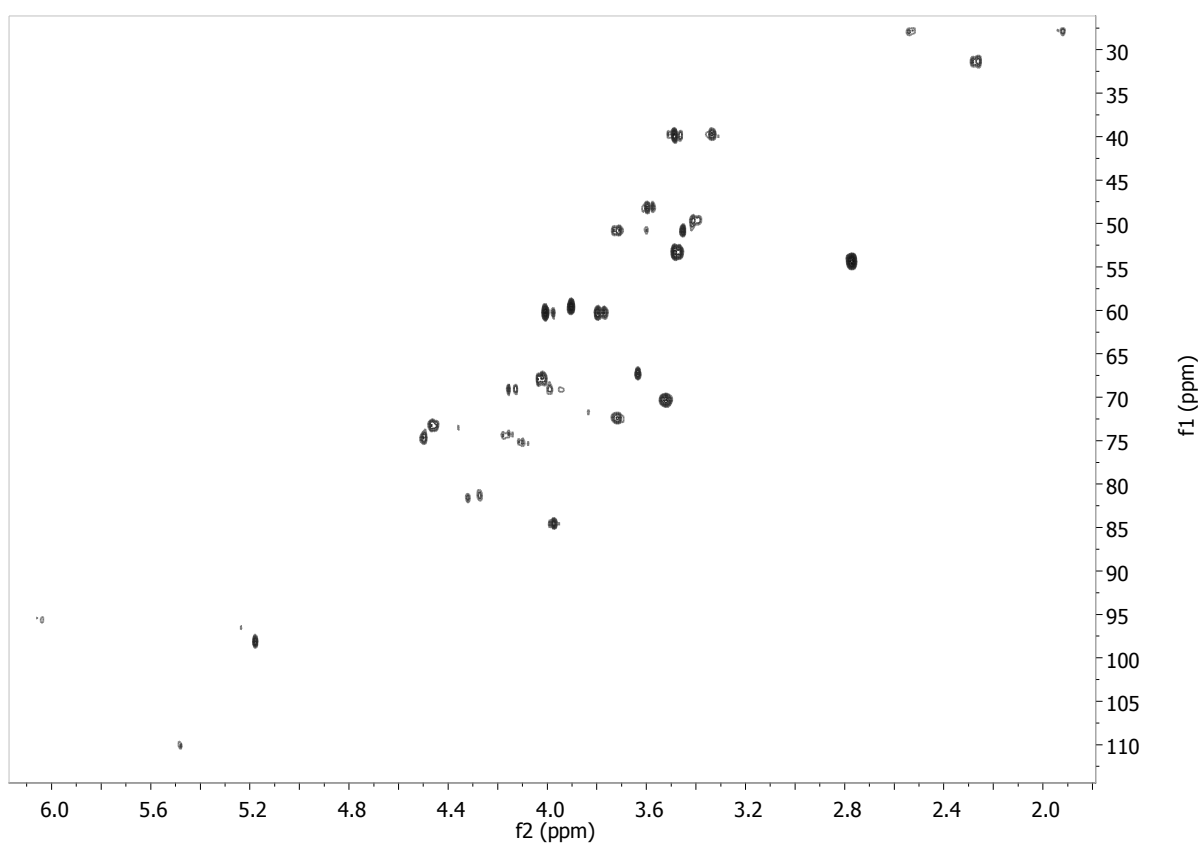

Figure 4.16b: ¹H-NMR (500 MHz, D₂O) spectrum of 2''', 6'''-di-azido neomycin B x 5 HFBA **18**.

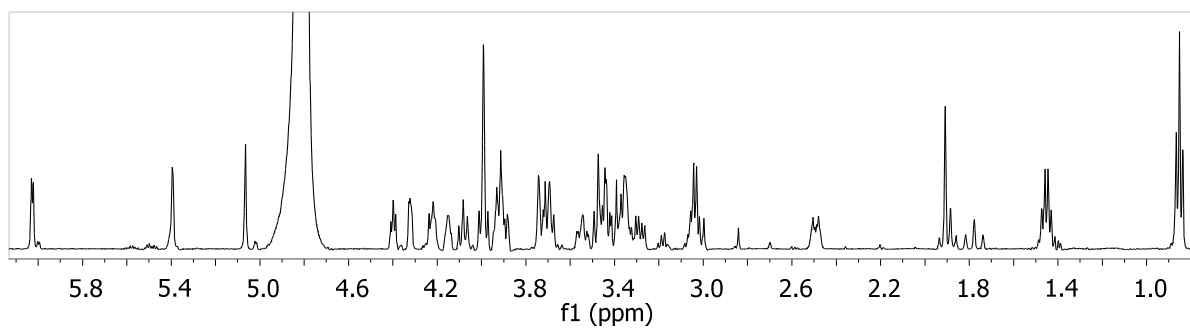

Figure 4.17a: $^1\text{H-NMR}$ (500 MHz, D_2O) spectrum of 2'''-*N*-(propylamino)carbonyl neomycin B x 5 HFBA 19a.

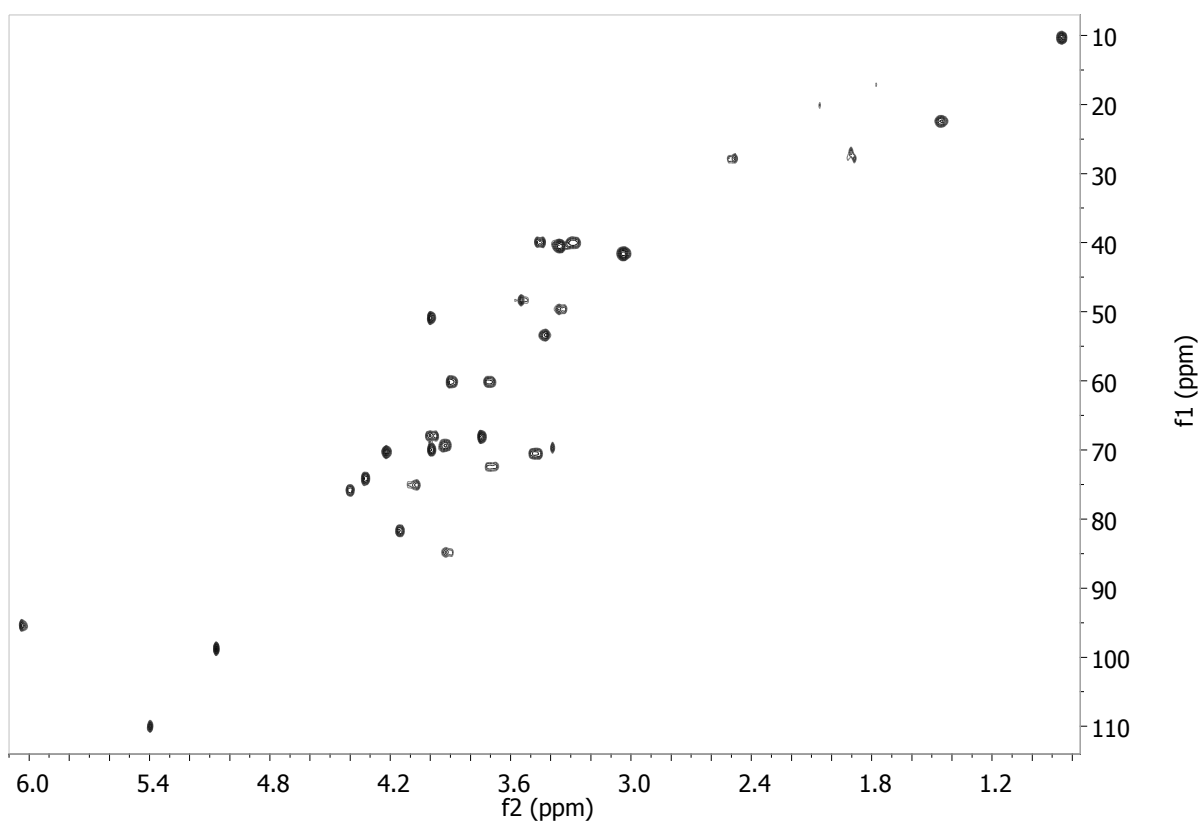

Figure 4.17b: HSQC (500 MHz, D_2O) spectrum of 2'''-*N*-(propylamino)carbonyl neomycin B x 5 HFBA 19a.

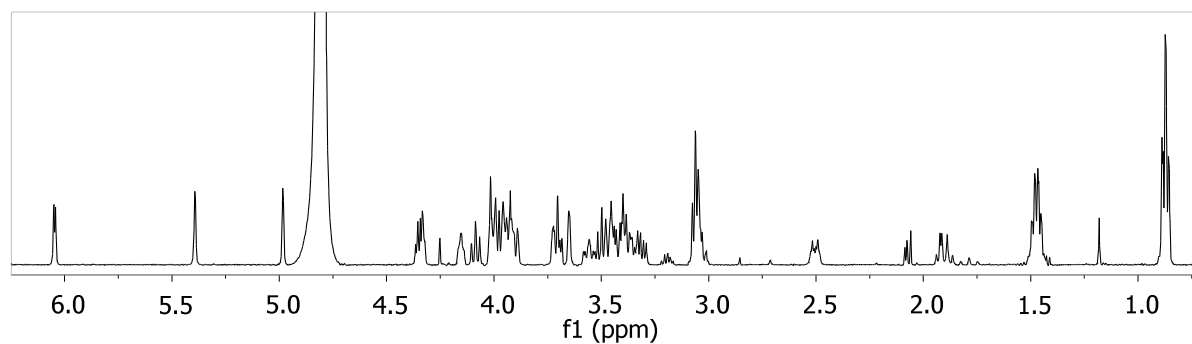

Figure 4.18a: $^1\text{H-NMR}$ (500 MHz, D_2O) spectrum of 6''', 2''' bis-*N*-(propylamino)carbonyl neomycin B x 5 HFBA **20a**.

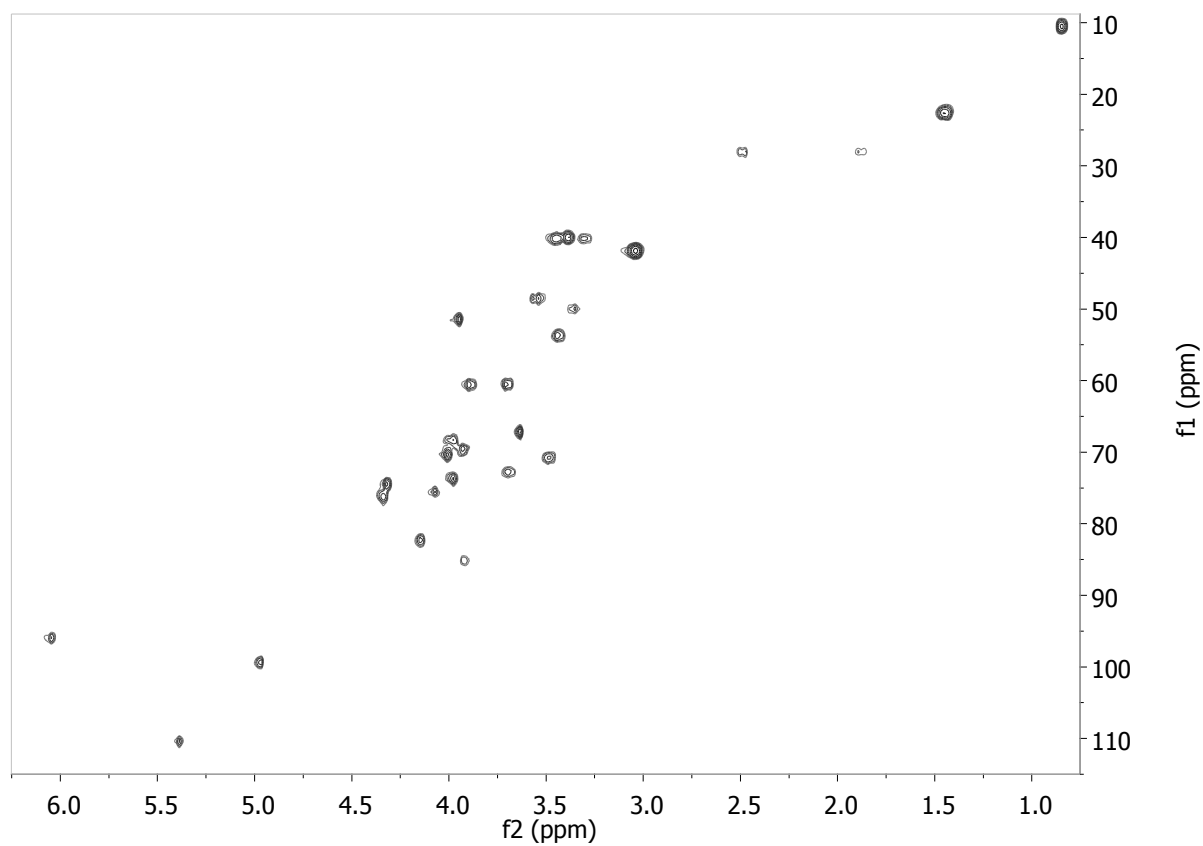

Figure 4.18b: HSQC (500 MHz, D_2O) spectrum of 6''', 2''' bis-*N*-(propylamino)carbonyl neomycin B x 5 HFBA **20a**.

4.4.5 High Resolution Mass Spectrometric Analysis

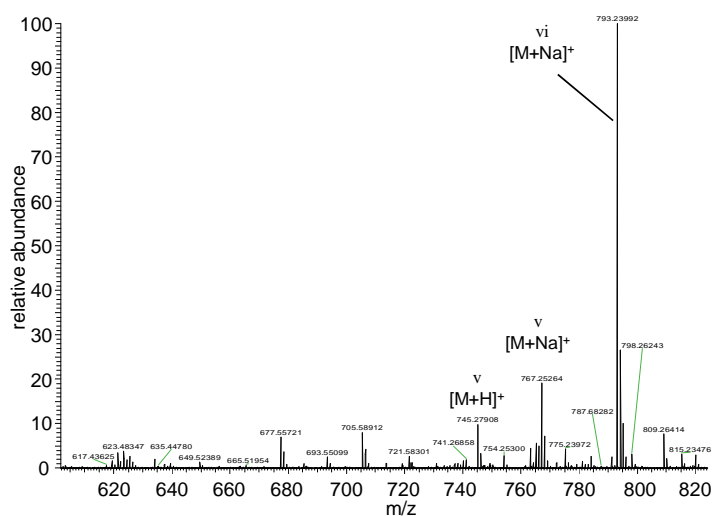

Figure 4.19: ESI-MS spectrum after transformation of neomycin B with 8 equiv. diazo-transfer reagent **8** in absence of APG (v-vi = number of introduced azide groups).

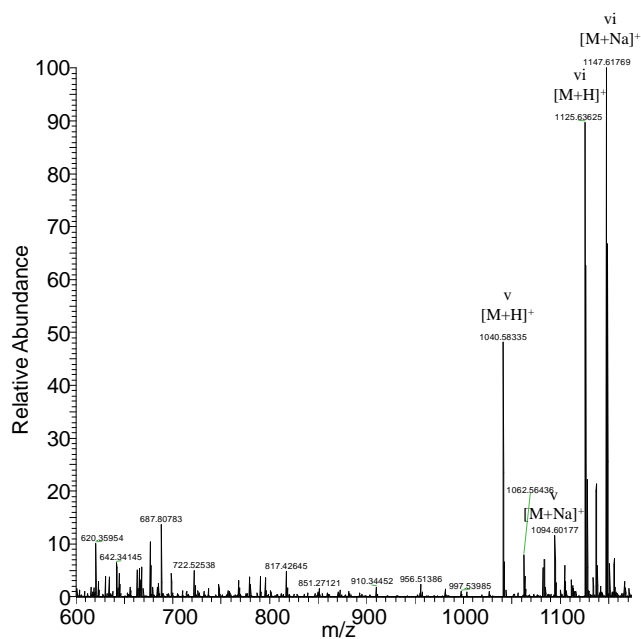

Figure 4.20: ESI-MS spectrum after transformation of neomycin B with 30 equiv. propyl isocyanate **9a** in absence of APG (v-vi = number of introduced urea groups).

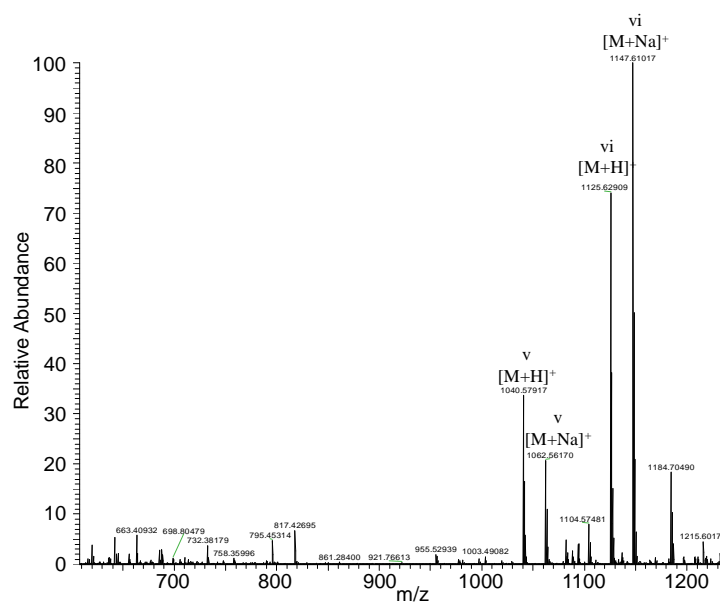

Figure 4.21: ESI-MS spectrum after transformation of neomycin B with 30 equiv. isopropyl isocyanate **9b** in absence of APG ($v-vi$ = number of introduced urea groups).

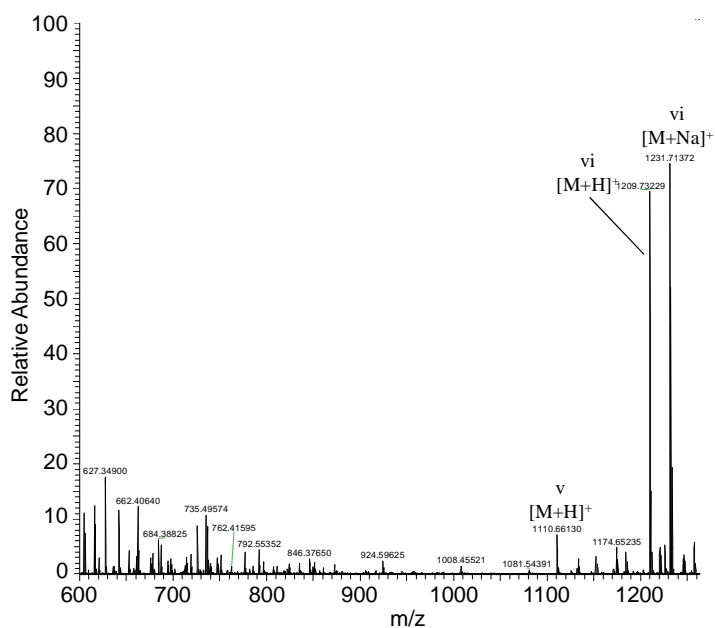

Figure 4.22: ESI-MS spectrum after transformation of neomycin B with 30 equiv. isopropyl isocyanate **9c** in absence of APG ($v-vi$ = number of introduced urea groups).

4.4.6 High Performance Liquid Chromatography Analysis

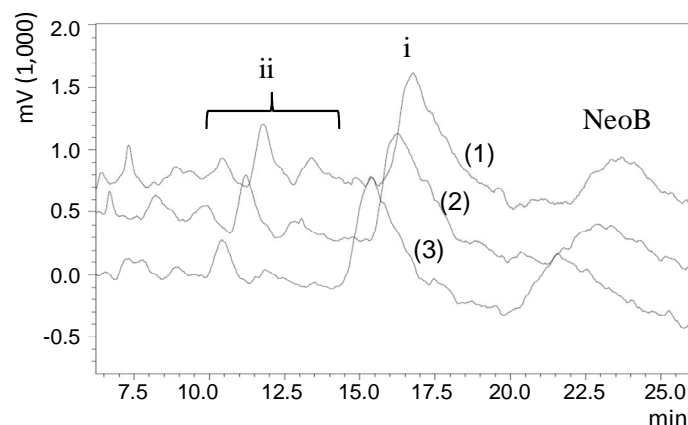

Figure 4.23: HPLC elugram after transformation of neomycin B (NeoB) with 30 (1), 15 (2) and 5 (3) equiv. 2-iminothiolane hydrochloride **6** in presence of APG **apt1** (i-ii = number of acylated amino groups).

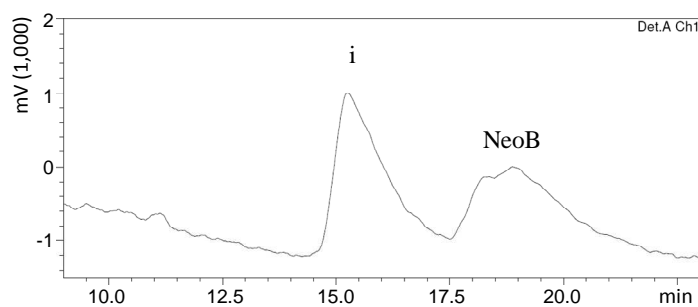

Figure 4.24: HPLC elugram after transformation of neomycin B (NeoB) with 15 equiv. p-methoxy phenyl isocyanate **7a** in presence of APG **apt2** (i = one urea group was introduced).

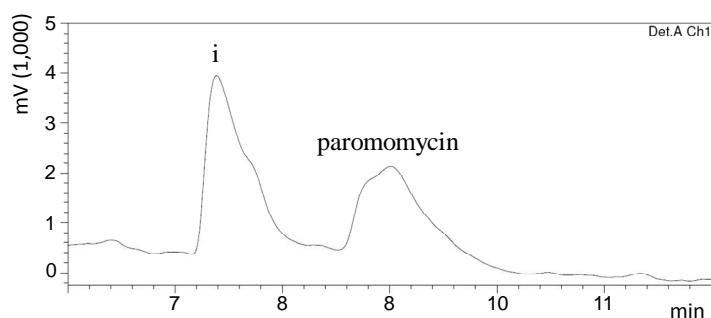

Figure 4.25: HPLC elugram after transformation of paromomycin with 15 equiv. p-methoxy phenyl isocyanate **7a** in presence of APG **apt1** (i = one urea group was introduced).

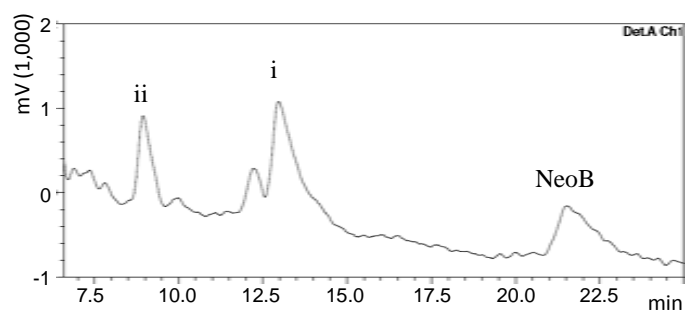

Figure 4.26: HPLC elugram after transformation of neomycin B (NeoB) using 8 equiv. of diazo-transfer reagent **8** in presence of APG **apt1** (i-ii = number of introduced azide groups).

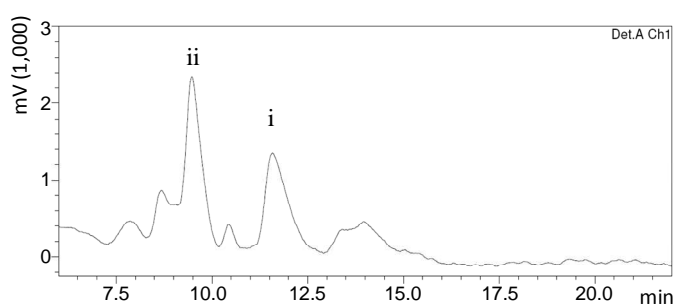

Figure 4.27: HPLC elugram after transformation of neomycin B (NeoB) with 30 equiv. propyl isocyanate **9a** in presence of APG **apt1** (i-ii = number of introduced urea groups).

4.5 References

- 1 Coquiere, D., de la Lande, A., Parisel, O., Prange, T. & Reinaud, O. Directional control and supramolecular protection allowing the chemo- and regioselective transformation of a triamine. *Chem.-Eur. J.* **15**, 11912-11917 (2009).
- 2 Cafeo, G., Kohnke, F. H. & Valenti, L. Regioselective O-alkylations and acylations of polyphenolic substrates using a calix 4 pyrrole derivative. *Tetrahedron Letters* **50**, 4138-4140 (2009).
- 3 Ellington, A. D., Szostak, J. W. *In vitro* selection of RNA molecules that bind specific ligands. *Nature* **346**, 818-822 (1990)
- 4 Wallis, M. G., Vonahsen, U., Schroeder, R. & Famulok, M. A novel RNA motif for neomycin recognition. *Chem. Biol.* **2**, 543-5524 (1995).
- 5 Famulok, M. Molecular recognition of amino-acids by RNA-apatmers - an L-citrulline binding RNA motif and its evolution into an L-arginine binder. *J. Am. Chem. Soc.* **116**, 1698-1706 (1994).
- 6 Cowan, J. A., Ohyama, T., Wang, D. Q. & Natarajan, K. Recognition of a cognate RNA aptamer by neomycin B: Quantitative evaluation of hydrogen bonding and electrostatic interactions. *Nucleic. Acids. Res.* **28**, 2935-2942 (2000).
- 7 Famulok, M. & Szostak, J. W. Stereospecific recognition of tryptophan agarose by invitro selected RNA. *J. Am. Chem. Soc.* **114**, 3990-3991 (1992).
- 8 Li, Y. F., Geyer, C. R. & Sen, D. Recognition of anionic porphyrins by DNA aptamers. *Biochemistry* **35**, 6911-6922 (1996).
- 9 Betat, H. *et al.* Aptamers that recognize the lipid moiety of the antibiotic moenomycin A. *Biol. Chem.* **384**, 1497-1500 (2003).
- 10 Stoltenburg, R., Reinemann, C., Strehlitz, B. SELEX-A (r)evolutionary method to generate high-affinity nucleic acid ligands. *Biomol. Eng.* **24**, 381-403 (2007).
- 11 Gold, L., Polisky, B., Uhlbeck, O., Yarus, M. Diveristy of oligonucleotide functions. *Annu. Rev. Biochem.* **64**, 763-797 (1995)
- 12 Wang, K. Y., McCurdy, S., Shea, R. G., Swaminathan, S. & Bolton, P. H. A DNA aptamer which binds to and inhibits thrombin exhibits a new structural motif for DNA. *Biochemistry* **32**, 1899-1904 (1993).
- 13 Wallis, M. G., Vonahsen, U., Schroeder, R. & Famulok, M. A novel RNA motif for neomycin recognition. *Chem. Biol.* **2**, 543-552 (1995).
- 14 Jiang, L. C. *et al.* Saccharide-RNA recognition in a complex formed between neomycin B and an RNA aptamer. *Struct. Fold. Des.* **7**, 817-827 (1999).
- 15 Yamamoto, T. *et al.* Synthesis of CMP-900-modified-sialic acids as donor substrate analogues for mammalian and bacterial sialyltransferases. *Carbohydrate Research* **342**, 1680-1688 (2007).
- 16 Gee, K. R., Archer, E. A., Kang, H. C. 4-Sulfotetrafluorophenyl (STP) esters: New water-soluble amine-reactive reagents for labeling biomolecules *Tetrahedron Letters* **40**, 1471-1474 (1999).
- 17 Stampfl, S., Lempradl, A., Koehler, G. & Schroeder, R. Monovalent ion dependence of neomycin B binding to an RNA aptamer characterized by spectroscopic methods. *Chem. Bio. Chem.* **8**, 1137-1145 (2007).

APGs Enable Various Transformations in Different Positions of Neamine Antibiotics

- 18 Traut, R.R., *et al.* Methyl 4-mercaptobutyrimidate as a cleavable cross-linking reagent and its application to the *Escherichia coli* 30S ribosome. *Biochem* **12**, 3266-3273 (1973).
- 19 Jue, R., *et al.* Addition of sulfhydryl groups to *Escherichia coli* ribosomes by protein modification with 2-iminothiolane (methyl 4-mercaptobutyrimidate). *Biochem* **17**, 5399-5405 (1978).
- 20 Wower, I. and Wower, J., Meinke, M., Brimacombe, R. The use of 2-iminothiolane as an RNA-protein cross-linking agent in *Escherichia coli* ribosomes, and the localization on 23S RNA of sites cross-linked to proteins L4, L6, L21, L23, L27 and L29. *Nucleic Acids Res* **9** 4285-4302 (1981).
- 21 Alagon, A.C. and King, T.P. Activation of polysaccharides with 2-iminothiolane and its uses. *Biochem.* **19**, 4341-4345 (1980).
- 22 Tarentino, A.L., *et al.* 2-iminothiolane: A reagent for the introduction of sulfhydryl groups into oligosaccharides derived from asparagine-linked glycans. *Glycobiology* **3**, 279-285 (1993).
- 23 Jack Hine, J., Evangelista, R. A. Iminium-ion formation and deuterium exchange by acetone in the presence of pyrrolidine, pyrazolidine, isoxazolidine, and their acyclic analogues. *J. Am. Chem. Soc.* **102**, 1649–1655 (1980).
- 24 Goddard-Borger, E. D., Stick, R. V. An efficient, inexpensive, and shelf-Stable diazotransfer reagent: Imidazole-1-sulfonyl Azide Hydrochloride *Org. Lett.* **9**, 3797-3800 (2007).
- 25 Schoffelen, S., van Eldijk, M. B., Rooijackers, B., Raijmakers, R., Heck, A. J. R., Hest, J. C. M. Metal-free and pH-controlled introduction of azides in proteins. *Chem. Sci.* **2**, 701-705 (2011).
- 26 Sawa, M., Hsu, T.-L., Itoh, T., Sugiyama, M., Hanson, S. R., Vogt, P. K., Wong, C.-H. Glycoproteomic probes for fluorescent imaging of fucosylated glycans in vivo. *Proc. Natl. Acad. Sci. U.S.A.* **103**, 12371-12376 (2006).
- 27 Vocadlo, D. J., Bertozzi, C. R. A strategy for functional proteomic analysis of glycosidase activity from cell lysates. *Angew. Chem. Int. Ed.* **43**, 5338-5342 (2004).

Chapter 5

Regioselective One-Step Diazo-Transfer Reaction in C3 Position of Neamine Antibiotics

(Based on this chapter a European patent application has been filed: A. Bastian, A. Herrmann 2012)

Since the mechanism of bacterial resistance against neamine antibiotics is well understood, modification of aminoglycosides is becoming a promising tool to overcome antibacterial resistance. However, regioselective derivatization of aminoglycoside antibiotics requires extensive total synthetic pathways or enzymatic approaches. Therefore, several methods were recently established allowing specific site modification of aminoglycosides. However, derivatization of the C3 position of the 2-desoxystreptamine ring in neamine antibiotics is restricted to enzymatic transformations. Here, we demonstrate a regioselective azide introduction in C3 position of diverse neamine antibiotics in a single step in aqueous buffer solution. In this study we show that the high regioselectivity is driven by the difference of pK_a value of the amino groups within the aminoglycoside.

5.1 Introduction

Aminoglycosides represent one of the largest classes of antibacterials with activity against Gram negative and Gram positive bacteria. These antibiotics exert their antibacterial activity by binding to the decoding site (A-site) in prokaryotic 16S ribosomal RNA.¹⁻³ However, increased bacterial resistance against aminoglycoside antibiotics⁴⁻⁶ forced activities to modify these scaffolds to obtain new active compounds.⁷ Especially the neamine moiety **1** of these antibiotics shown in Figure 5.1 attracted major attention, since the bacterial resistance is mainly based on the enzymatic modifications at ring I and II. The introduction of negatively charged phosphate groups at ring II by 3'-phosphotransferase (APH-3') and erasing of positive charges at ring II and I by acetyltransferases (ACCs) reduces their biological activity.⁸ Thus, chemical derivatization of the hydroxy group at the C3 position of ring II and transformations at the amino group in the C1 position of ring I were carried out to overcome bacterial resistance.^{9,10} For example, the acylation of the amino group in C1 position of the 2-desoxystreptamine ring (2-DOS, ring I) enabled the facile development of the semi-synthetic antibiotic amikacin **2** (Fig. 5.1). However, due to the presence of multiple hydroxy- and amino groups with similar reactivity, most regioselective modifications of aminoglycoside antibiotics require multi-step synthesis.^{9,11-13} Therefore, several methods were established enabling facile regioselective introduction of functionalities in structurally complex molecules. These methods are based on non-covalent protective group strategies^{14,15} or enzymatic approaches.^{16,17} Moreover, derivatization of the C3 position of 2-DOS ring is still a challenge and was successfully realized only for neamine **1** by extensive synthetic routes resulting in low overall yield.^{11,18} In this study, we describe a one-step modification of the same position within structurally more complex aminoglycoside antibiotics without the use of enzymes, covalent or non-covalent protective groups. This synthetic shortcut is based on regioselective azide introduction in C3 position at ring I of neamine antibiotics **3-6** (Fig. 5.1) in a single step employing a diazo-transfer reagent. This cost-efficient and highly scalable method does not require any protection or deprotection steps and is performed in aqueous solution.

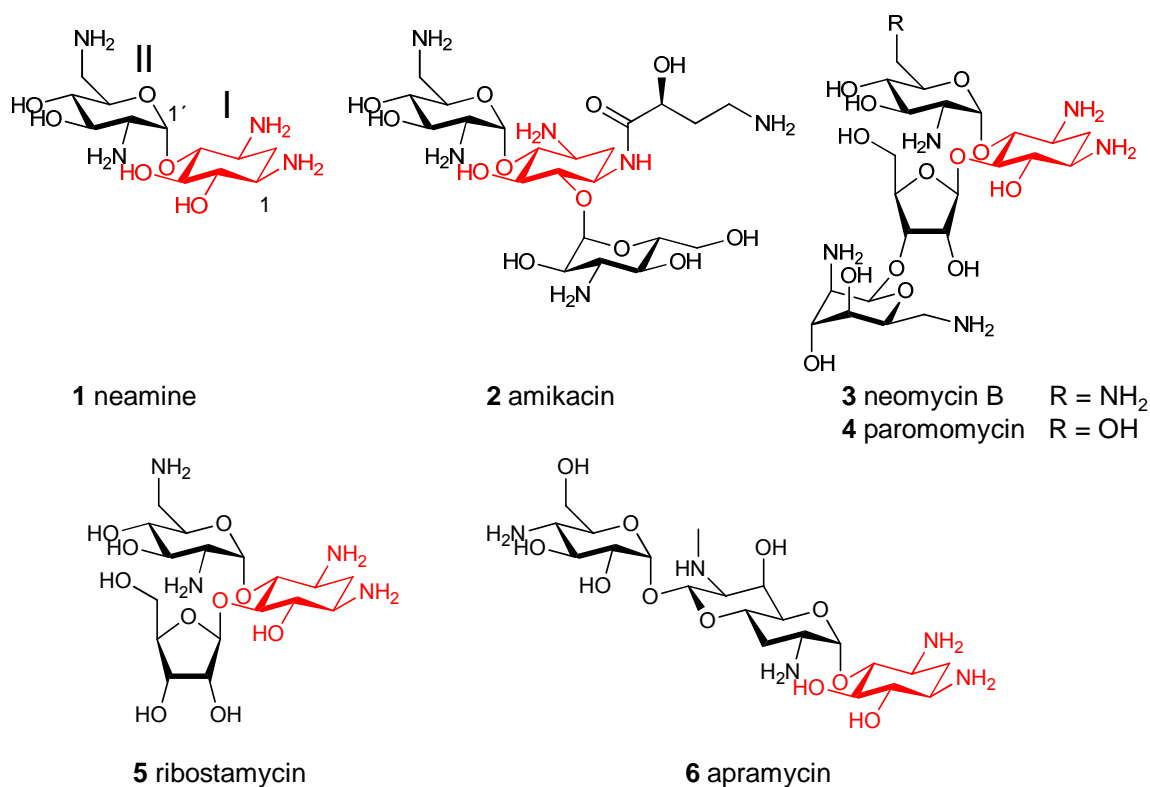
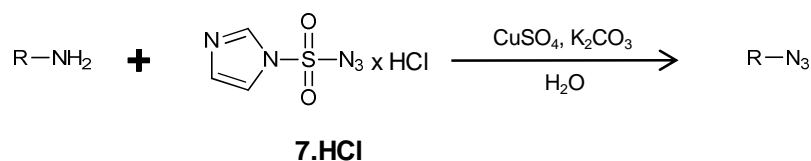

Figure 5.1: Chemical structure of neamine **1** and aminoglycoside antibiotics **2-6**. The red structural unit corresponds to 2-desoxystreptamine ring (2-DOS).

5.2 Result & Discussion

5.2.1 Identification of Reaction Conditions for Regioselective Azide Introduction

To enable the regioselective azide introduction in neamine antibiotics, imidazole-1-sulfonyl azide **7** was applied as a diazo-transfer reagent (Scheme 5.1). The “diazo donor” **7** has been recently introduced as a shelf-stable, non-explosive and water soluble reagent.¹⁹ Moreover, it has proven to be a straightforward tool to convert free amines into azides via an aqueous diazo-transfer reaction (Scheme 5.1).



Scheme 5.1: Azide introduction applying imidazole-1-sulfonyl azide **7** as diazo-transfer reagent.

The crystalline and more stable hydrochloride of **7** was applied to a wide range of molecules resulting in excellent yields and reasonable reaction times.¹⁹ Another advantage of this reagent is a good functional group tolerance and high reactivity even in absence of metal catalyst, such as copper(II), nickel(II) or zinc(II).²⁰ In 2011, *van Hest et al.* applied imidazole-1-sulfonyl azide hydrochloride **7.HCl** to introduce an azide in proteins.²⁰ It was shown that the N-terminus could be selectively transformed, while more basic amines of lysine residues were not converted at lower pH values and in absence of a catalyst. Inspired by this work, we tested the applicability of **7.HCl** for the regioselective azide introduction to neomycin B **3**, which has several amine groups with pK_a values ranging from 5.7 to 8.8 (Fig 5.2).²¹ In particular, the acidic amine group in C3 position of the 2-DOS ring seemed to be a valuable target.

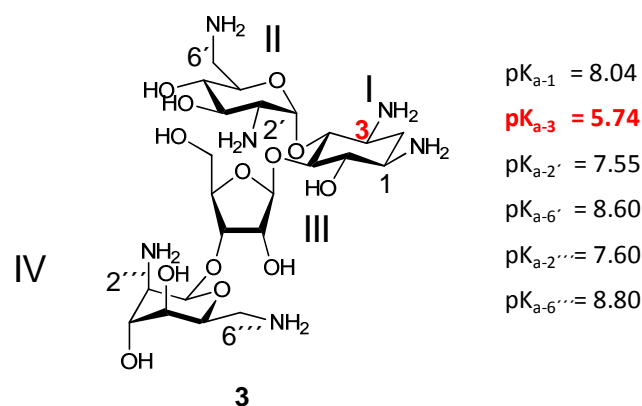

Figure 5.2: Chemical structure of neomycin B. The pK_a values of the amino groups of neomycin B were determined by NMR spectroscopy by *Botto* and coworkers.²¹

Firstly, it was tested whether all amino groups of antibiotic **3** are reactive with **7.HCl**. Transformation was carried out under basic conditions and in presence of Cu(II) sulfate as a catalyst. After a reaction time of 18 hours the number of reacted amino groups was determined by **Electrospray Ionisation Mass Spectroscopy (ESI-MS)**. As shown in Figure 5.3a, applying eight equivalents of **7.HCl** all six amino groups of neomycin B **3** were reactive in presence Cu(II) ions and of sodium carbonate at pH 8. To decrease the activity of some amino groups, antibiotic **3** was reacted in absence of the catalyst (Fig. 5.3b). According to mass spectrometric analysis, under these conditions only four amino groups of neomycin B were reactive. Similar results were obtained in previous studies when Lysozyme was employed as a substrate for **7.HCl**.²⁰

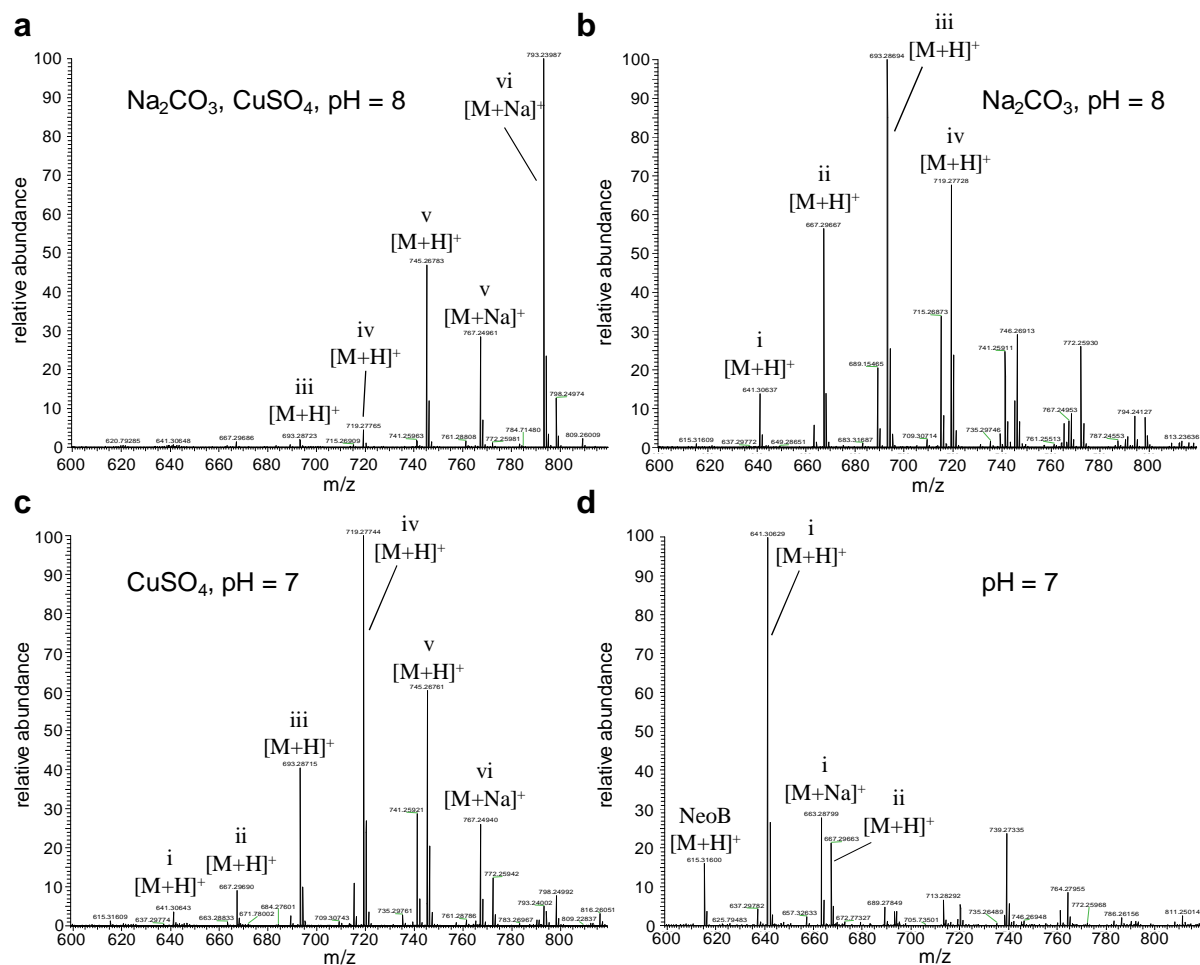

Figure 5.3: ESI-MS spectra of neomycin B (NeoB) after azide introduction using 8 equiv. of diazo-transfer reagent **7.HCl** at different pH values performed in presence and absence of Cu(II) (i-vi = number of introduced amino groups).

To investigate the influence of the pH value on the reactivity of **7** with aminoglycoside **3**, we carried out the same set of reactions at slightly lower pH, i.e. pH = 7. As shown in Figure 5.3c, up to five amino groups of neomycin B are still reactive in presence of Cu(II), while in the absence of the catalyst only one amine was converted and traces of a second amine reacted (Fig. 5.3d). Despite the utilization of eight equivalents of diazo-transfer reagent **7.HCl**, five out of six amino groups seemed not to be reactive. Furthermore, we compared the conversion of neomycin B with **7.HCl** under the most and less reactive conditions by High Performance Liquid Chromatography (HPLC) analysis. As shown in Figure 5.4a, the transformation of **3** at pH 8 in presence of Cu(II) results in a mixture of derivatives exhibiting three to six azide groups. Whereas, in absence of Cu(II) and at neutral pH the transformation of antibiotic **3** resulted mainly in *mono*-azido neomycin B derivatives reaching a conversion of 82 % (Fig. 5.4b).

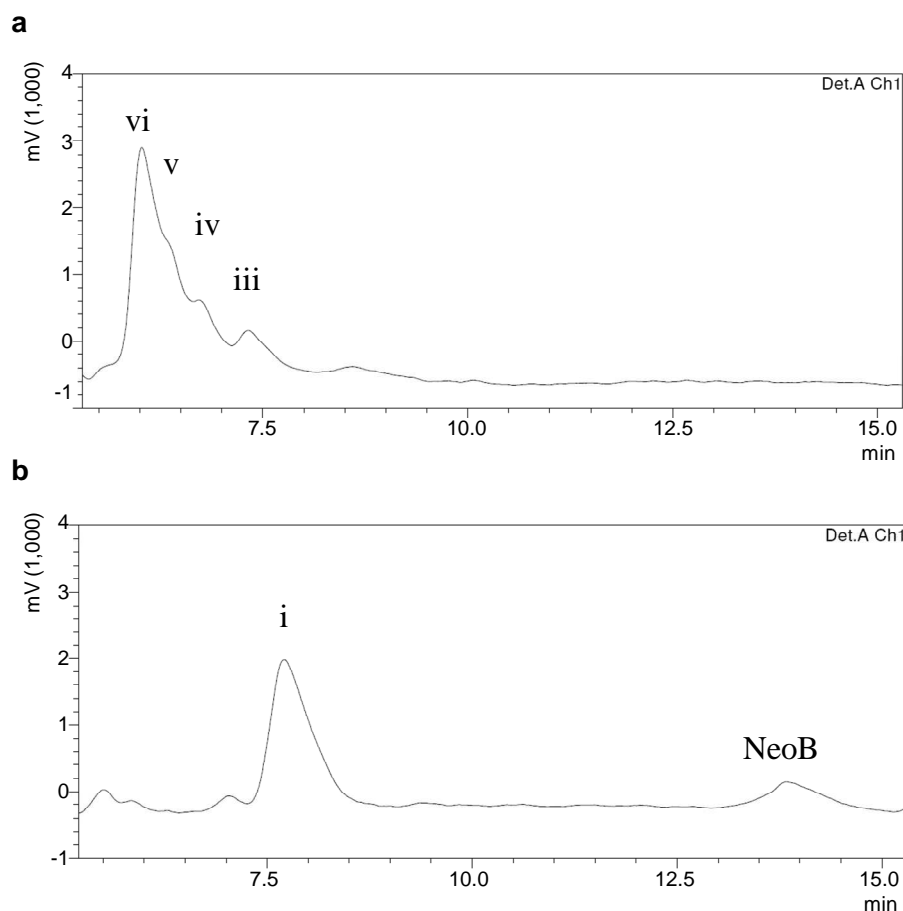

Figure 5.4: HPLC elugrams of neomycin B (NeoB) after transformation using eight equivalents of **7.HCl** as diazo-transfer reagent in presence of Cu(II) at pH 8 (a) and in absence of Cu(II) at pH 7 (b) (i-vi = number of introduced amino groups).

Conclusively, we successfully indentified conditions to enable a transformation of a single amino group of neomycin B in aqueous solution. Thus, applying a buffer solution of pH 7 and eight equivalents of diazo-transfer reagent **7.HCl** a single amine of antibiotic **3** is transformed to an azide without the use of metal catalysts.

5.2.2 Identification of the Position of Diazotation

In the next step, the HPLC fraction containing *mono*-azido neomycin B derivatives was purified and characterized by 1D- and 2D-NMR spectroscopy to determine at which position the azide was introduced. As shown in Figure 5.5a, neomycin B was transformed regioselectively at the 2-DOS ring resulting in aminoglycoside derivative **8**.

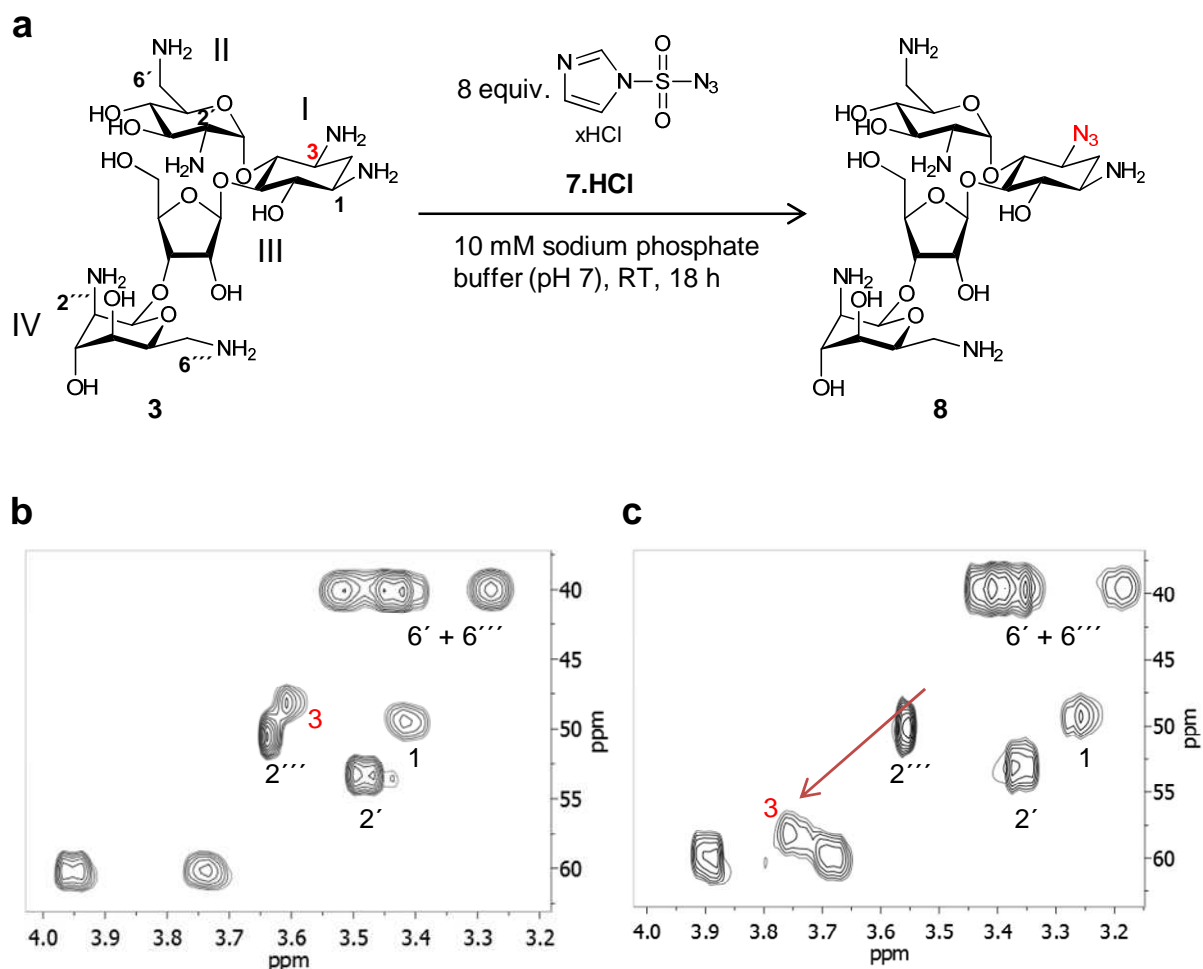

Figure 5.5: a, Regioselective azide introduction in C3 position of 2-DOS ring applying diazo-transfer reagent **7.HCl**. b, Section of HSQC (500 MHz, D₂O) spectrum of neomycin B. c, Section of HSQC (500 MHz, D₂O) spectrum of antibiotic derivative **8**. Arrow indicates the chemical shift of $J(\text{C}3\text{-H})$ coupling.

The HSQC spectrum of derivative **8** (Fig. 5.5c) shows that the amino group in C3 position of 2-DOS ring reacted regioselectively. In comparison to the 2D-spectrum of neomycin B (Fig. 5.5b) the $J(\text{C}3\text{-H})$ coupling shows a remarkable chemical shift to lower field proving the regioselective azide introduction at this position. As determined by ¹H-NMR spectroscopy (see experimental part Fig. 5.7a), the regioselectivity of the reaction is approx. 90 %. The

selective transformation of the amino group in C3 position can be explained by differences of the basicity of the amine. While five out of six amino groups have a pK_a value ranging from 7.55 to 8.8, the amine in C3 position of the 2-DOS ring is acidic with a pK_a of 5.74 (Fig. 5.2)²¹. Therefore, only this amino group is mainly accessible for the reagent **7.HCl** under applied conditions, while all other amines are protonated and inactive for transformation.

5.2.3 Regioselective Azide Introduction in Other Neamine Antibiotics

To test whether other antibiotics exhibiting the neamine moiety can be transformed selectively at the same position, we investigated the azide introduction using diazo-transfer reagent **7.HCl** employing neamine **1**, amikacin **2** paromomycin **4**, ribostymacin **5**, and apramycin **6** as substrates (Scheme 5.2). Mass spectrometric analysis confirmed the result previously obtained for neomycin B showing high activity of mainly one amino group (see experimental part 5.4.7). As shown in Scheme 5.2, all applied aminoglycosides **1**, **2**, **3**, **4**, **5**, **6** were transformed at the C3 position of the 2-DOS ring resulting in aminoglycoside derivatives **9-13** even when applying an excess of 16 equivalents of **7.HCl**. All substrates were successfully converted with high regioselectivity ranging from 90 % to 98 % and yields between 40 % and 62 %. While for the transformation of antibiotics **3** and **4** a regioselectivity of approx. 90 % was measured, the modification of aminoglycosides **1**, **2**, **5** and **6** proceeded with regioselectivities higher than 95%.

The regioselective azide introduction at the 2-DOS ring is a very useful modification, since this functionality can be applied for further chemical diversifications, i.e. *Staudinger* and *Huisgen* reaction.^{22,23} As shown in Scheme 5.3, the transformation of an azide allows the introduction of carbamates, primary amine and amides²⁴ and can be reacted with acetylenes via “click reaction” resulting in 1,2,3-triazoles.²³ Since these reactions can also be applied in aqueous solution, the water soluble aminoglycoside derivatives **8-13** (Scheme 5.2) can be directly transformed in an additional reaction step to a wide range of new promising antibiotics without any protection and deprotection steps.

Regioselective One-Step Diazo-Transfer Reaction in C3 Position of Neamine Antibiotics

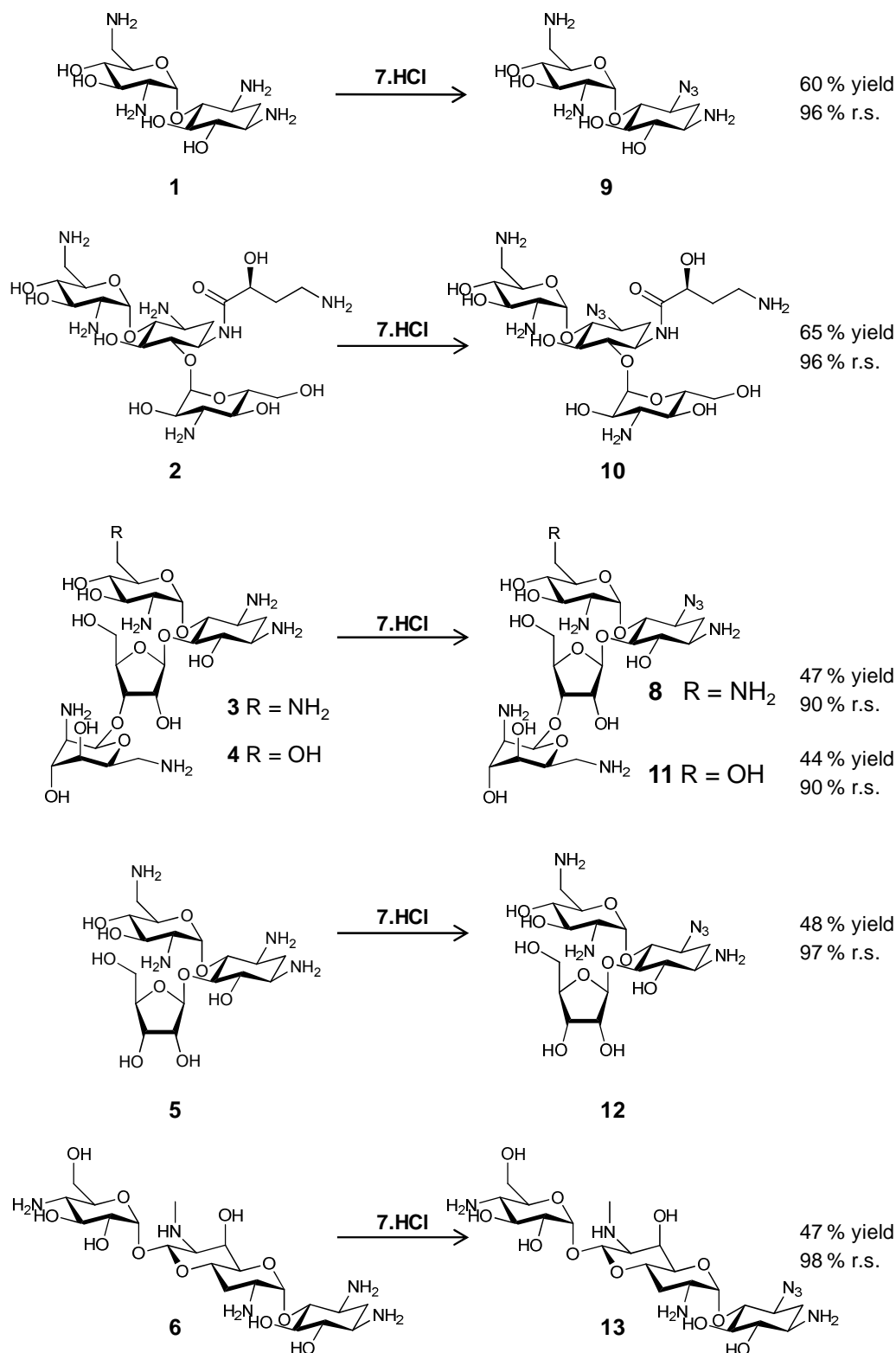

Scheme 5.2: Yields and regioselectivities of transformation of neamine antibiotics using imidazole-1-sulfonyl azide **7.HCl**. Reactions were performed according the general procedure (see experimental part 5.4.3) using 16 equiv. diazo-transfer reagent **7.HCl** at room temperature and 18 hours reaction time. Yields were calculated from HPLC- and ¹H-NMR peak integrals. Regioselectivities (r.s.) were calculated using ¹H-NMR spectroscopy.

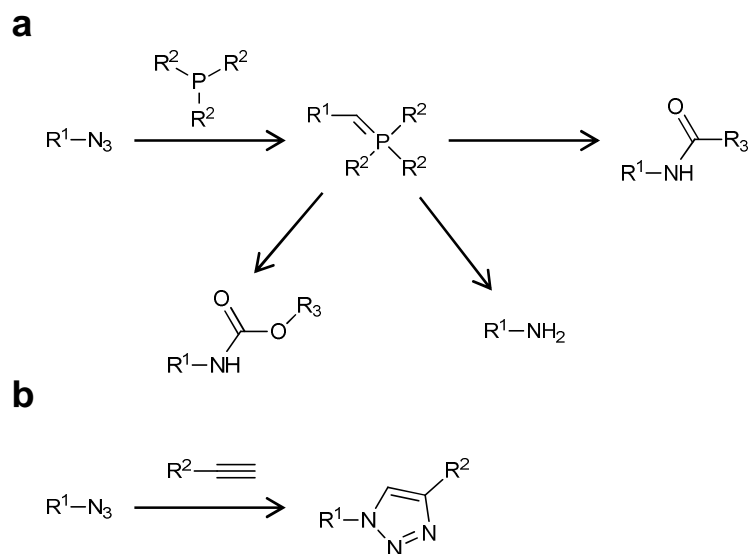

Scheme 5.3: Transformation of an azide group applying *Staudinger* (a) and *Huisgen* (b) reaction

5.3 Conclusion

In this chapter, imidazole-1-sulfonyl azide hydrochloride **7.HCl** was successfully applied as diazo-transfer reagent for regioselective azide introduction in neamine antibiotics without the application of protective group chemistry. We demonstrated that the reactivity of amino groups within aminoglycoside antibiotics can be controlled by addition of catalyst and changing the pH value. It was demonstrated, that the key to the regioselective transformation of the amino group in C3 position of the 2-desoxystreptamine ring is its low pK_a value. Therefore, high regioselectivities (up to 98%) were reached applying carefully chosen conditions for the transformation of the antibiotics. This facile one-step modification at the C3 position of neamine antibiotics will accelerate the development of new promising antibiotics overcoming antibacterial resistance.

5.4 Experimental Section

5.4.1 Materials & Methods

¹H-NMR- and heteronuclear single-quantum correlation (HSQC) spectra and Attached Proton Test (APT) were recorded on a Varian Unity Inova (500 MHz for ¹H-NMR and HSQC, 125 MHz for APT) and Oxford AS400 (400 MHz for ¹H-NMR and 100.6 MHz for APT and ¹³C-NMR) NMR spectrometer at 25 °C. High resolution mass spectrometry (HRMS) was carried out on a LTQ ORBITRAP XL instrument (Thermo Scientific) employing electron impact ionization in positive ion mode (EI+). Chromatographic separations were carried out on a *Shimadzu* VP series HPLC modular system (DGU-14A3 Online Vacuum-Degasser, two LC-20 AT pumps, SIL-20A auto sampler, CTP-20 A column oven, RID-10 refractive detector, FRC-10 A fraction collector and Shimadzu LCsolution software). HPLC purification was performed with a Waters Spherisorb ODS-2 C₁₈ analytical (250 x 4.6 mm) and semi-preparative column (250 x 10mm) (spherical particles of 5 μm and 80 Å pore size) using isocratic elution at 40 °C. A pH-meter (Hanna Instruments pH 209) equipped with a glass combination electrode was used for pH adjustments of the reaction buffers.

All chemicals and reagents were purchased from commercial suppliers and used without further purification, unless otherwise noted. Neomycin B trisulfate x hydrate (VETRANAL[®]), paromomycin sulfate salt (98 %), ribostamycin sulfate salt, apramycin sulfate salt, amikacin sulfate salt, sulfuryl chloride (97 %), sodium azide (95 %), acetonitril (99.8 %), imidazole (99 %) and methanolic 3N HCl solution were purchased from *Sigma Aldrich* and used as received. For HPLC purification *heptafluorobutyric acid* (HFBA) (*Fluka*, puriss. p.a., for ion chromatography) and acetone (*Sigma-Aldrich*, HPLC grade) were used. Ultrapure water (specific resistance > 18.4 MΩ cm) was obtained by Milli-Q water purification system (*Sartorius*[®]). Neamine hydrochloride was synthesized according to known procedure.²⁵

5.4.2 Synthesis of Diazo-Transfer Reagent, Imidazole-1-sulfonyl Azide **7** Hydrochloride¹⁹

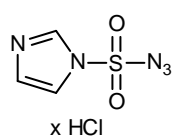

A volume of 1.6 mL of sulfonyl chloride (20 mmol) was added drop wise to an ice-cooled suspension of 1.3 g sodium azide (20 mmol) in 20 mL acetonitrile and the mixture was stirred overnight at room temperature. Then 2.6 g of imidazole (38 mmol) were added portion-wise to the ice-cooled mixture and the resulting slurry was stirred for additional 3h at room temperature. The reaction mixture was diluted with 40 mL ethyl acetate, washed twice with 40 mL water and then twice with 40 mL sat. aqueous NaHCO₃ solution, dried over MgSO₄ and filtered. The filtrate was cooled in an ice-bath and a 10 mL of a 3M HCl methanolic solution were added drop wise to precipitate the product. Finally, the filter cake was washed three times with 10 mL EtOAc to obtain **7** as colorless hydrochloride salt. Yield: 1.9 g (9.1 mmol, 45% yield). ¹H-NMR (D₂O, 400 MHz) δ (p.p.m.) 9.53 (s, 1H, H-2), 8.07 (s, 1H, H-5), 7.67 (s, 1H, H-4). ¹³C-NMR (D₂O, 100.6 MHz) δ (p.p.m.) 137.6, 122.6, 120.18. HRMS (EI+) (*m/z*): found 174.0078 [M-Cl]⁺, calc. 174.0080 [M-Cl]⁺.

5.4.3 General Procedures for Regioselective Azide Introduction

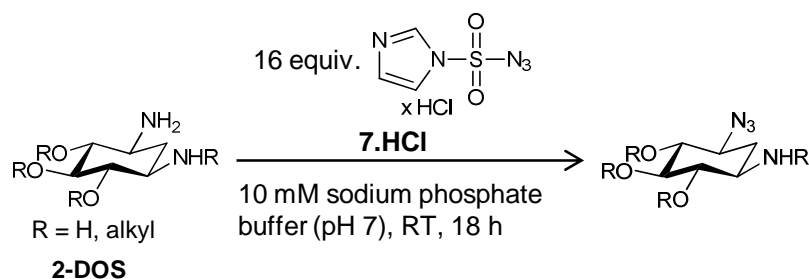

Scheme 5.4: Regioselective transformation in C3 position of 2-desoxystreptamine (2-DOS) ring in neamine antibiotics.

Synthesis of Antibiotic Derivatives, 3-Azido Neomycin B **8** and 3-Azido Paromomycin **11**:

After 11 μmol aminoglycoside antibiotic were dissolved in 7.5 mL of 10 mM sodium phosphate buffer (pH 7.3), 3.7 mL of a 48 mM aqueous solution of diazo-transfer reagent **7.HCl**, which was adjusted to pH 8.0 by adding aq. 2 M NaOH solution, were added into the solution of the antibiotic and the reaction mixture was stirred for 18h at room temperature. The reaction was quenched by adding 0.9 mL aqueous 7 wt % ethylamine solution. After

Regioselective One-Step Diazo-Transfer Reaction in C3 Position of Neamine Antibiotics

incubating at room temperature for 30 min the reaction mixture was freeze dried. Then the crude mixture was dissolved in 1.5 mL water and each 30 μ L fraction was purified by HPLC using a Waters Spherisorb ODS-2C₁₈ analytic column (water/acetone 1:0.9 containing 12.1 mM HFBA) at a flow rate of 1 ml/min at 40°C to afford the antibiotic derivatives **8** and **11**.

Synthesis of Antibiotic Derivatives 3-Azido Amikacin **10** and 3-Azido Apramycin **13**:

After 11 μ mol aminoglycoside antibiotic were dissolved in 7.5 mL of 10 mM sodium phosphate buffer (pH 7.3), 3.7 mL of a 48 mM aqueous solution of diazo-transfer reagent **7.HCl**, which was adjusted to pH 8.0 by adding 2 M NaOH solution, were added into the solution of the antibiotic and the reaction mixture was stirred for 18h at room temperature. By addition of 1 M aqueous HCl solution a pH value of 2 was adjusted and each 100 μ L fraction was purified by HPLC using a Waters Spherisorb ODS-2C₁₈ analytic column (water/acetone 1:0.9 containing 12.1 mM HFBA) at a flow rate of 1 ml/min at 40°C to afford the antibiotic derivatives **10** and **13**.

Synthesis of Antibiotic Derivatives 3-Azido Neamine **9** and 3-Azido Ribostamycin **12**:

After 11 μ mol aminoglycoside antibiotic were dissolved in 7.5 mL of 10 mM sodium phosphate buffer (pH 7.3), 3.7 mL of a 48 mM aqueous solution of diazo-transfer reagent **7.HCl**, which was adjusted to pH 8.0 by adding 2 M NaOH solution, were added into the solution of the antibiotic and the reaction mixture was stirred for 18h at room temperature. The reaction was quenched by adding 0.9 mL aqueous 7 wt % ethylamine solution. After incubating at room temperature for 30 min, the reaction mixture was freeze dried and the crude mixture was purified by column chromatography using the upper layer of the two phase system CHCl₃/MeOH/17%NH₃ 2:1:1 as eluent. After evaporation at reduced pressure and freeze drying the antibiotic derivatives was dissolved in 1.5 mL water. Each 30 μ L fraction was purified by HPLC using a Waters Spherisorb ODS-2C₁₈ analytic column (water/acetone 1:0.9 containing 12.1 mM HFBA) at a flow rate of 1 ml/min at 40°C to afford the antibiotic derivatives **9**, **12**.

5.4.4 Characterization of Synthesized Antibiotic Derivatives

C-3-azido neomycin B x 5 HFBA (8). The title compound was prepared according to the

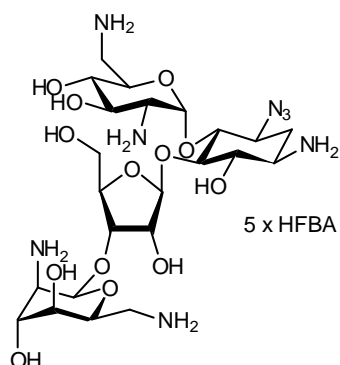

general procedure described above. Derivative **8** was obtained as a white solid. For the measurement of regioselectivity and the characterization of the compound $^1\text{H-NMR}$, HSQC and APT spectra were recorded and electrospray ionization (ESI)-MS was employed. The yield was determined by HPLC: $R_t = 7.7$ min, 47 % yield. TLC: $R_f = 0.57$ ($\text{CHCl}_3/\text{MeOH}/17\%\text{NH}_3$ 2:1:1 v/v/v).

$^1\text{H-NMR}$ (D_2O , 500 MHz) δ (p.p.m.) 5.72 (d, $J = 4$ Hz, 1H, 1-H'), 5.33 (d, $J = 1.5$ Hz, 1H, 1-H''), 5.26 (s, 1H, 1-H'''), 4.40 (t, $J = 5.5$ Hz, 1H, 3-H'), 4.37 (dd, $J = 4.5$ Hz, $J = 2$ Hz, 1H, 2-H'), 4.28 (t, $J = 5$ Hz, 1H, 5-H'''), 4.27 (m, 1H, 5-H'), 4.21 (m, 2H, 3-H''', 4-H'), 3.91-3.85 (m, 2H, 5-H_a'', 3-H'), 3.80-3.75 (m, 3H, 4-H''', 5-H, 3-H), 3.72-3.67 (m, 2H, 4-H, 5-H_b'), 3.58 (t, $J = 10$ Hz, 1H, 6-H), 3.56 (s(br), 1H, 2-H'''), 3.47-3.33 (m, 5H, 6-H_a', 6-H_a''', 6-H_b''', 4-H', 2-H'), 3.26 (dt, $J = 11.25$ Hz, $J = 3.5$ Hz, 1H, 1-H), 3.19 (dd, $J = 13.5$ Hz, $J = 8$ Hz, 1H, 6-H_b'), 2.47 (dt, $J = 13$ Hz, $J = 4$ Hz, 1H, 2-H_eq), 1.70 (dd, $J = 12.3$ Hz, 1H, 2-H_ax). APT (D_2O , 125.7 MHz) δ (p.p.m.) 109.84 (C-1'), 94.51 (C-1'''), 94.30 (C-1'), 84.89 (C-5), 80.48 (C-4'), 76.26 (C-4), 74.86 (C-3'), 72.84 (C-2'), 71.72 (C-6), 69.81 (C-4'), 69.05 (C-5'''), 68.00 (C-3'), 67.68 (C-5'), 66.77 (C-3'''), 66.72 (C-4'''), 59.88 (C-5'), 58.14 (C-3), 53.01 (C-2'), 50.15 (C-2'''), 49.21 (C-1), 39.67 (C-6'''), 39.55 (C-6'), 28.72 (C-2). $M = \text{C}_{23}\text{H}_{44}\text{N}_8\text{O}_{13}$; HRMS (EI+) (m/z): found 641.30652 $[\text{M}+\text{H}]^+$, calc. 657.31006 $[\text{M}+\text{H}]^+$.

C-3-azido paromomycin x 4 HFBA (11). The title compound was prepared according to the

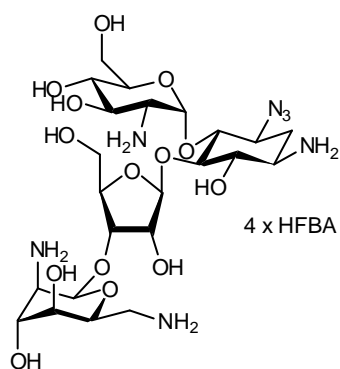

general procedure described above. Derivative **11** was obtained as a white solid. For the measurement of regioselectivity and the characterization of the compound $^1\text{H-NMR}$ and HSQC and spectra were recorded and electrospray ionization (ESI)-MS was employed. The yield was determined by HPLC: $R_t = 5.9$ min, 44 % yield. TLC: $R_f = 0.64$ ($\text{CHCl}_3/\text{MeOH}/17\%\text{NH}_3$ 2:1:1 v/v/v).

$^1\text{H-NMR}$ (D_2O , 500 MHz) δ (p.p.m.) 5.72 (d, $J = 3$ Hz, 1H, 1-H'), 5.33 (s, 1H, 1-H''), 5.26 (s, 1H, 1-H'''), 4.48 (t, $J = 5.5$ Hz, 1H, 3-H'), 4.38 (d, $J = 4$ Hz, 1H, 2-H'), 4.28 (m, 1H, 5-H'''), 4.22-4.16 (m, 2H, 3-H''', 4-H'), 4.02 (d, $J = 9.5$ Hz, 1H, 5-H'), 3.92-3.84 (m, 2H, 5-H_a'', 3-H'), 3.82-3.75 (m, 4H, 4-H''', 6-H_a', 6-H_b', 5-H), 3.73-3.63 (m,

3H, 5-H_b'', 4-H, 3-H), 3.57 (t, J = 10 Hz, 1H, 6-H), 3.56 (s(br), 1H, 2-H'''), 3.50 (t, J = 9.75 Hz, 1H 4-H'), 3.44 (dd, J = 17.5 Hz, J = 9.5 Hz, 1H, 6-H_a'''), 3.39-3.34 (m, 2H, 6-H_b''', 2-H'), 3.25 (dt, J = 11.5 Hz, J = 3.5 Hz, 1H, 1-H), 2.44 (dt, J = 12.5 Hz, J = 4Hz, 1H, 2-H_{eq}), 1.67 (dd, J = 12.15 Hz, 1H, 2-H_{ax}). ¹³C-signals based on HSQC (D₂O, 500 MHz) δ (p.p.m.) 110.3 (C-1''), 95.11 (C-1'), 94.9 (C-1'''), 85.3 (C-5), 80.67 (C-4'), 76.8 (C-4), 74.9 (C-3''), 73.1 (C-2''), 72.5 (C-5'), 72.2 (C-6), 69.9 (C-5'''), 69.1 (C-3'), 68.7 (C-4'), 67.3 (C-3'''), 67.0 (C-4'''), 60.0 (C-5'), 59.6 (C-6'), 58.4 (C-3), 53.8 (C-2'), 50.5 (C-2'''), 49.6 (C-1), 40.0 (C-6'''), 29.1 (C-2). C₂₃H₄₃N₇O₁₄; HRMS (EI+) (m/z): found 642.29346 [M+H]⁺, calc. 642.29408 [M+H]⁺.

C-3-azido ribostamycin x 3 HFBA (12). The title compound was prepared according to the

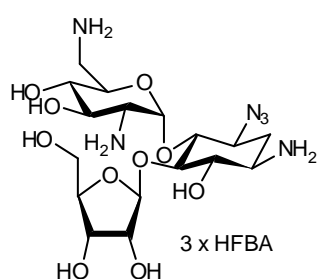

general procedure described above. Derivative **12** was obtained as a white solid. For the measurement of regioselectivity and the characterization of the compound ¹H-NMR and HSQC spectra were recorded and electrospray ionization (ESI)-MS was employed. The yield was determined by HPLC: R_t = 4.1 min, 48 % yield. TLC: R_f = 0.73 (CHCl₃/MeOH/17%NH₃ 2:1:1 v/v/v).

¹H-NMR (D₂O, 500 MHz) δ (p.p.m.) 5.77 (d, J = 3.5 Hz, 1H, 1-H'), 5.31 (d, J = 1.5 Hz, 1H, 1-H''), 4.28 (dt, J = 9 Hz, J = 3 Hz, 1H, 5-H'), 4.21 (dd, J = 4.5 Hz, J = 3Hz, 1H, 2-H''), 4.15 (t, J = 7.5 Hz, J = 4.5 Hz, 1H, 3-H''), 4.05 (dt, J = 6.5 Hz, J = 2.5 Hz, 1H, 4-H'), 3.93-3.88 (m, 2H, 5-H_a'', 3-H'), 3.82-3.72 (m, 3H, 3-H, 5-H, 4-H), 3.65 (dd, H = 12.5 Hz, J = 6.5 Hz, 1H, 5-H_b''), 3.60 (t, J = 9.8 Hz, 1H, 6-H), 3.48-3.43 (m, 2H, 4-H', 6-H_a'), 3.39 (dd, J = 10.5 Hz, J = 4.0 Hz, 1H, 2-H'), 3.29 (dt, J = 11.5 Hz, J = 4.0 Hz, 1H, 1-H), 3.23 (dd, J = 13.5 Hz, J = 7.5 Hz, 1H 6-H_b'), 2.50 (dt, 12.5 Hz, J = 4.0 Hz, 1H, 2-H_{eq}), 1.73 (dd, J = 12.5 Hz, 1H, 2-H_{ax}). ¹³C-signals based on HSQC (D₂O, 500 MHz) δ (p.p.m.) 110.6 (C-1''), 95.0 (C-1'), 85.5 (C-5), 82.1 (C-4'), 76.7 (C-4), 75.0 (C-2''), 72.3 (C-6), 70.3 (C-4'), 68.9 (C-3''), 68.8 (C-3'), 68.3 (C-5'), 60.9 (C-5'''), 58.4 (C-3), 53.5 (C-2'), 49.5 (C-1), 39.9 (C-6'), 29.1 (C-2). C₁₇H₃₂N₆O₁₀; HRMS (EI+) (m/z): found 481.22470 [M+H]⁺, calc. 481.22470 [M+H]⁺.

C-3-azido neamine x 3 HFBA (9). The title compound was prepared according to the general

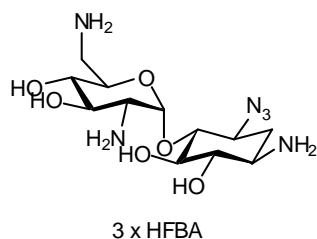

procedure described above. Derivative **9** was obtained as a white solid. For the measurement of regioselectivity and the characterization of the compound $^1\text{H-NMR}$ and HSQC spectra were recorded and electrospray ionization (ESI)-MS was employed. The yield was determined by HPLC: $R_t = 2.3$ min, 60 %

yield. TLC: $R_f = 0.71$ ($\text{CHCl}_3/\text{MeOH}/17\%\text{NH}_3$ 2:1:1 v/v/v). $^1\text{H-NMR}$ (D_2O , 500 MHz) δ (p.p.m.) 5.69 (d, $J = 3.5$ Hz, 1H, 1-H'), 4.23 (t, $J = 9.0$ Hz, 1H, 5-H'), 3.93 (t, $J = 10.0$ Hz, 1H, 3-H'), 3.80 (dt, $J = 10.8$ Hz, $J = 5.0$ Hz, 1H, 3-H), 3.68 (t, $J = 9.3$ Hz, 1H, 5-H), 3.63 (t, $J = 9.0$ Hz, 1H, 4-H), 3.53 (t, $J = 9.8$ Hz, 1H, 6-H), 3.50-3.46 (m, 2H, 4-H', 6-H_a'), 3.43 (dd, $J = 11.0$ Hz, $J = 3.5$ Hz, 1H, 2-H'), 3.32-3.24 (dt, 2H, 1-H, 6-H_b'), 2.51 (dt, $J = 13.0$ Hz, $J = 4.5$ Hz, 1H, 2-H_{eq}), 1.77 (dd, $J = 12.5$ Hz, 1H, 2-H_{ax}). ^{13}C -signals based on HSQC (D_2O , 500 MHz) δ (p.p.m.) 95.4 (C-1'), 78.8 (C-5), 74.8 (C-4), 72.2 (C-6), 70.3 (C-4'), 68.6 (C-3'), 68.2 (C-5'), 58.2 (C-3), 53.3 (C-2'), 49.4 (C-1), 39.7 (C-6'), 29.1 (C-2). $\text{C}_{12}\text{H}_{24}\text{N}_6\text{O}_6$; HRMS (EI+) (m/z): found 349.18066 $[\text{M}+\text{H}]^+$, calc. 349.18301 $[\text{M}+\text{H}]^+$.

C-3-azido amikacin x 4 HFBA (10). The title compound was prepared according to the

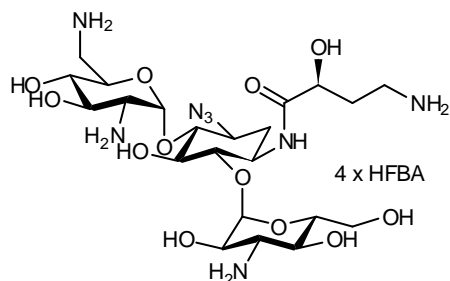

general procedure described above. Derivative **10** was obtained as a white solid. For the measurement of regioselectivity and the characterization of the compound $^1\text{H-NMR}$ and HSQC spectra were recorded and electrospray ionization (ESI)-MS was employed. The yield was determined by HPLC: $R_t = 3.7$ min, 65 %

yield. TLC: $R_f = 0.34$ ($\text{CHCl}_3/\text{MeOH}/17\%\text{NH}_3$ 2:1:1 v/v/v). $^1\text{H-NMR}$ (D_2O , 500 MHz) δ (p.p.m.) 5.50 (d, $J = 4$ Hz, 1H, 1-H'), 5.14 (d, $J = 3.5$ Hz, 1H, 1-H''), 4.26 (dd, $J = 9$ Hz, $J = 3.5$ Hz, 1H, α -H_a), 4.17 (dt, $J = 8.8$ Hz, $J = 3$ Hz, 1H, 5-H'), 4.09-4.04 (m, 2H, 1-H, 3-H'), 3.80 (s, 2H, 6-H''_a, 6-H''_b), 3.78-3.71 (m, 4H, 6-H, 5-H, 5-H'', 2-H''), 3.69-3.66 (m, 2H, 4-H', 3-H), 3.62-3.55 (m, 2H, 2-H', 4-H), 3.44-3.35 (m, 3H, 6-H_a', 3-H'', 4-H''), 3.23-3.16 (m, 3H, 6-H_b', γ -H_a, γ -H_b), 2.22-2.13 (m, 2H, 2-H_{eq}, β -H_a), 1.95 (m, 1H, β -H_b), 1.66 (dd, $J = 12.7$ Hz, 1H, 2-H_{ax}). ^{13}C -signals based on HSQC (D_2O , 500 MHz) δ (p.p.m.) 98.1 (C-1'), 97.2 (C-1''), 80.5 (C-4), 78.9 (C-6), 74.4 (C-5), 71.7 (C-5''), 71.1 (C-3'), 70.6 (C-2'), 70.1 (C-4'), 68.9 (C- α), 67.5 (C-5'), 67.5 (C-2''), 64.7 (C-4''), 59.0 (C-6''), 58.6 (C-3), 54.6 (C-3''), 48.2 (C-1), 39.7 (C-6'), 36.2 (C- γ), 31.1 (C-2), 30.1 (C- β); signal of quaternary carbon (CO) is

missing due to the fact that it is not detectable by HSQC spectroscopy. $M = C_{22}H_{41}N_7O_{13}$; HRMS (EI+) (m/z): found 612.27999 $[M+H]^+$, calc. 612.28351 $[M+H]^+$.

C-3-azido apramycin x 4 HFBA (13). The title compound was prepared according to the general procedure described above. Derivative **13** was obtained as a white solid. For the measurement of regioselectivity and the characterization of the compound 1H -NMR and HSQC spectra were recorded and electrospray ionization (ESI)-MS was employed. The yield was determined by HPLC:

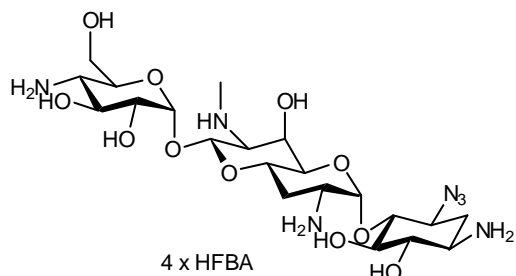

$R_t = 5.8$ min, 47 % yield. TLC: $R_f = 0.89$ ($CHCl_3/MeOH/17\%NH_3$ 2:1:1 v/v/v). 1H -NMR (D_2O , 500 MHz) δ (p.p.m.) 5.52 (d, $J = 4$ Hz, 1H, 1- H''), 5.51 (d, $J = 4$ Hz, 1H, 1- H'), 5.25 (d, $J = 8.5$ Hz, 1H, 8- H'), 4.54 (s, 1H, 6- H'), 3.04-3.93 (m, 4H, 3- H'' , 5- H'' , 4- H' , 5- H'), 3.87 (dd, $J = 12.5$ Hz, $J = 3$ Hz, 1H, 6- H_a''), 3.81 (dd, $J = 12.5$ Hz, $J = 4.5$ Hz, 1H, 6- H_b''), 3.73 (dd, $J = 10$ Hz, $J = 4$ Hz, 1H, 2- H''), 3.68-3.62 (m, 3H, 4-H, 3-H, 2- H'), 3.60 (t, $J = 9$ Hz, 1H, 5-H), 3.51 (t, $J = 9.8$ Hz, 1H, 6-H), 3.40 (dd, $J = 8.5$ Hz, $J = 2.5$ Hz, 1H, 7- H'), 3.82 (t, $J = 10.3$ Hz, 1H, 4- H''), 3.26 (dt, $J = 11.5$ Hz, $J = 4$ Hz, 1H, 1-H), 2.82 (s, 3H, CH_3), 2.48 (dt, $J = 13$ Hz, $J = 4.3$ Hz, 1H, 2- H_{eq}), 2.39 (dt, $J = 11$ Hz, $J = 4.3$ Hz, 1H, 3- H_{eq}), 2.04 (dd, $J = 12$ Hz, 1H, 3- H_{ax}), 1.73 (dd, $J = 12.3$ Hz, 1H, 2- H_{ax}). ^{13}C -signals based on HSQC (D_2O , 500 MHz) δ (p.p.m.) 98.8 (C-1'), 97.6 (C-1''), 95.8 (C-8'), 83.2 (C-4), 77.9 (C-5), 75.1 (C-6), 73.0 (C-2'), 72.1 (C-5'), 71.9 (C-3'), 70.9 (C-5''), 68.6 (C-4'), 65.5 (C-6'), 62.8 (C-6''), 62.3 (C-7'), 61.1 (C-3), 54.6 (C-4'), 52.4 (C-1), 50.6 (C-2'), 32.4 (N- CH_3), 32.1 (C-2), 29.2 (C-3'). $M = C_{21}H_{39}N_7O_{11}$; HRMS (EI+) (m/z): found 566.27484 $[M+H]^+$, calc. 566.27803 $[M+H]^+$.

5.4.5 NMR-Spectra of Neomycin B & Synthesized Antibiotic Derivatives

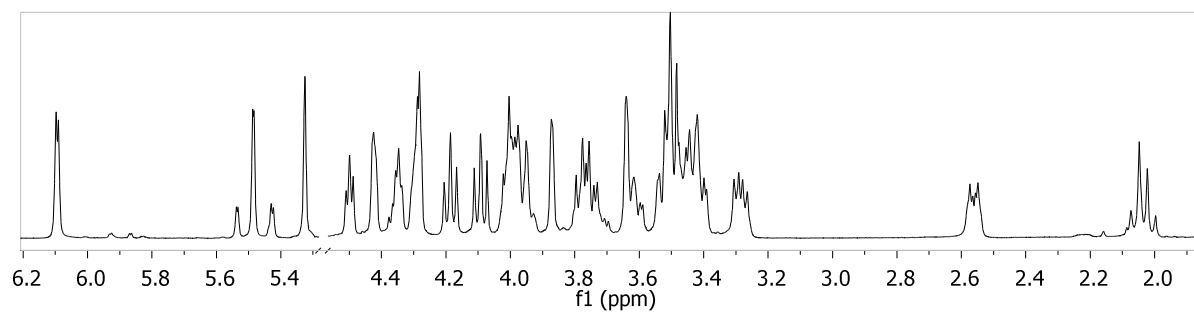

Figure 5.6a: ^1H -NMR (500 MHz, D_2O) spectrum of neomycin B x 6 HFBA **3**.

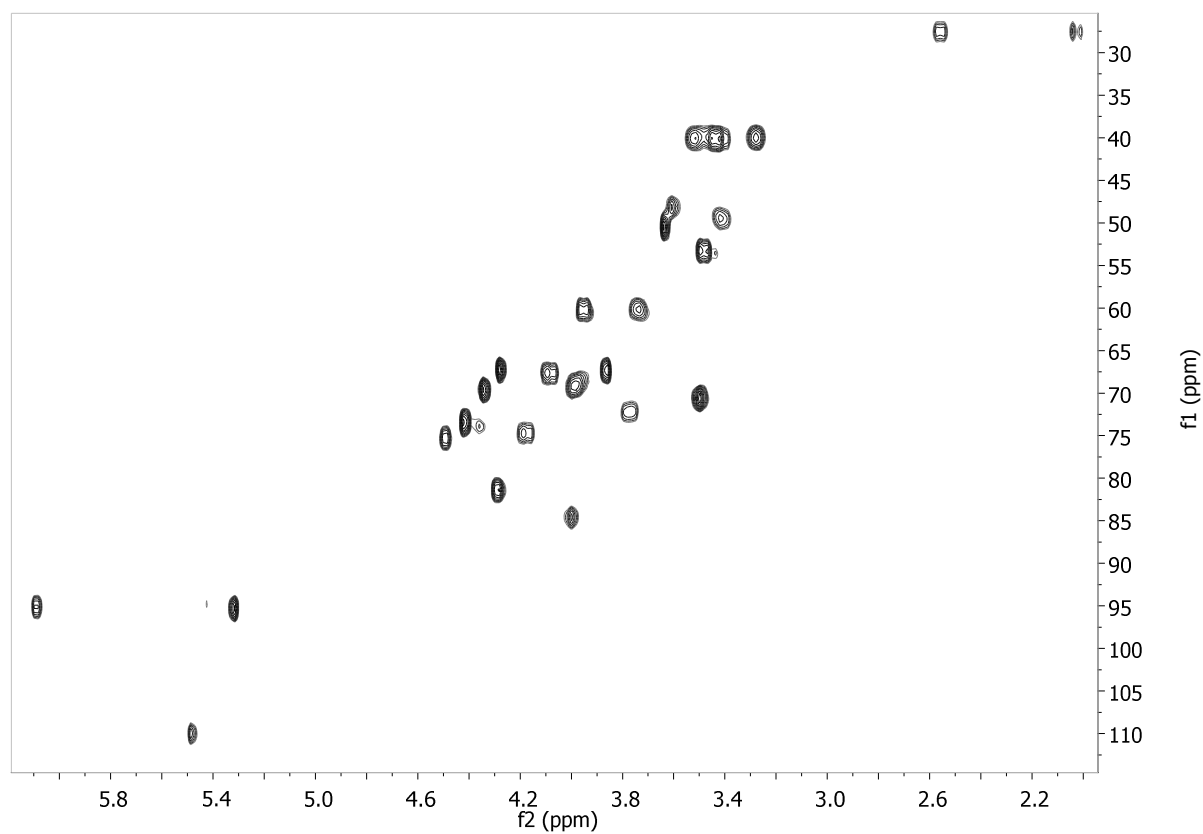

Figure 5.6b: HSQC (500 MHz, D_2O) spectrum of neomycin B x 6 HFBA **3**.

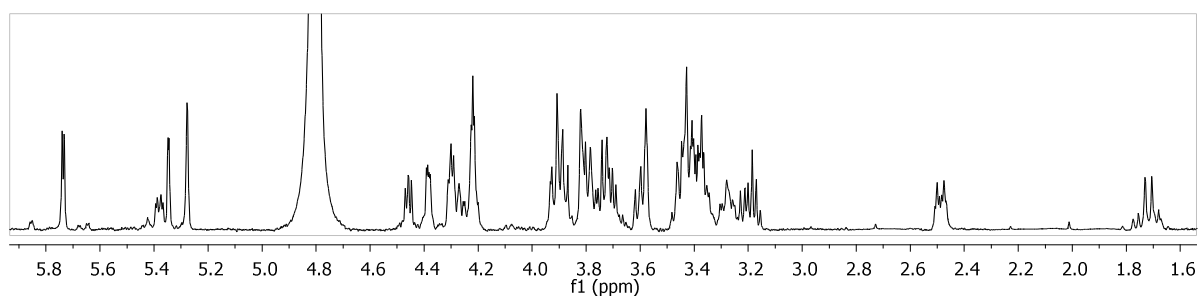

Figure 5.7a: $^1\text{H-NMR}$ (500 MHz, D_2O) spectrum of 3-C-azido neomycin B x 5 HFBA **8**.

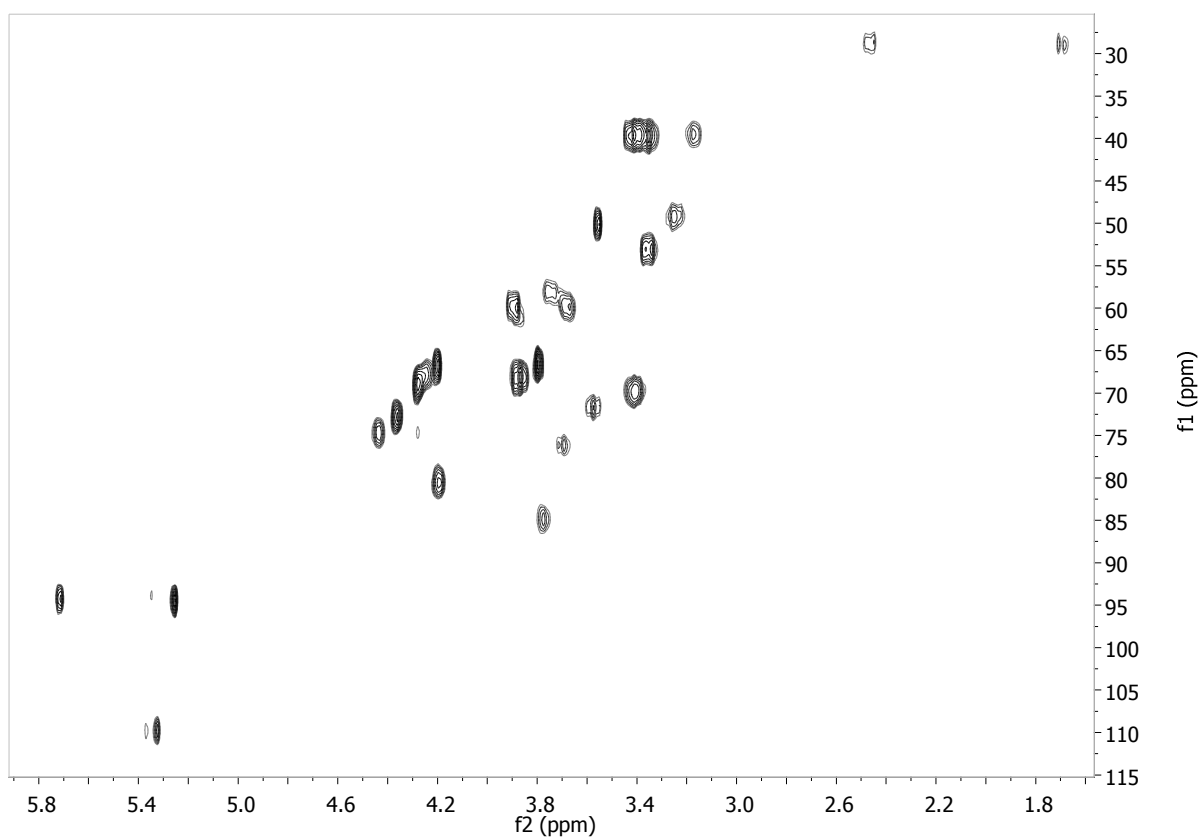

Figure 5.7b: HSQC (500 MHz, D_2O) spectrum of 3-C-azido neomycin B x 5 HFBA **8**.

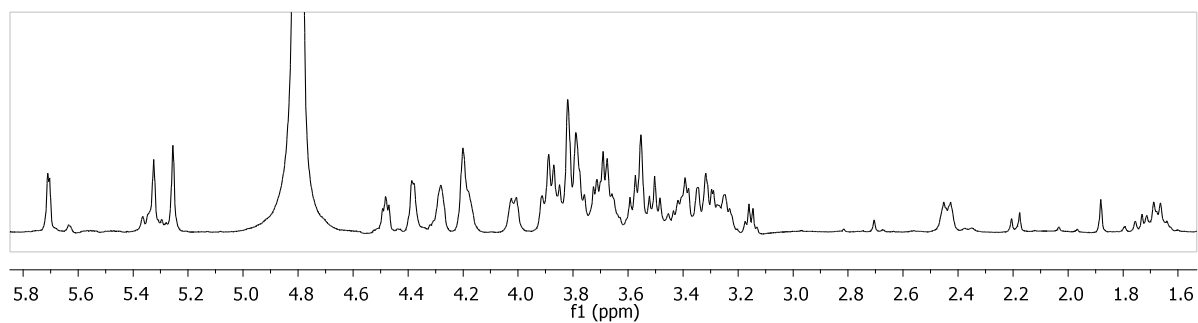

Figure 5.8a: $^1\text{H-NMR}$ (500 MHz, D_2O) spectrum of 3-C-azido paromomycin x 4 HFBA 11.

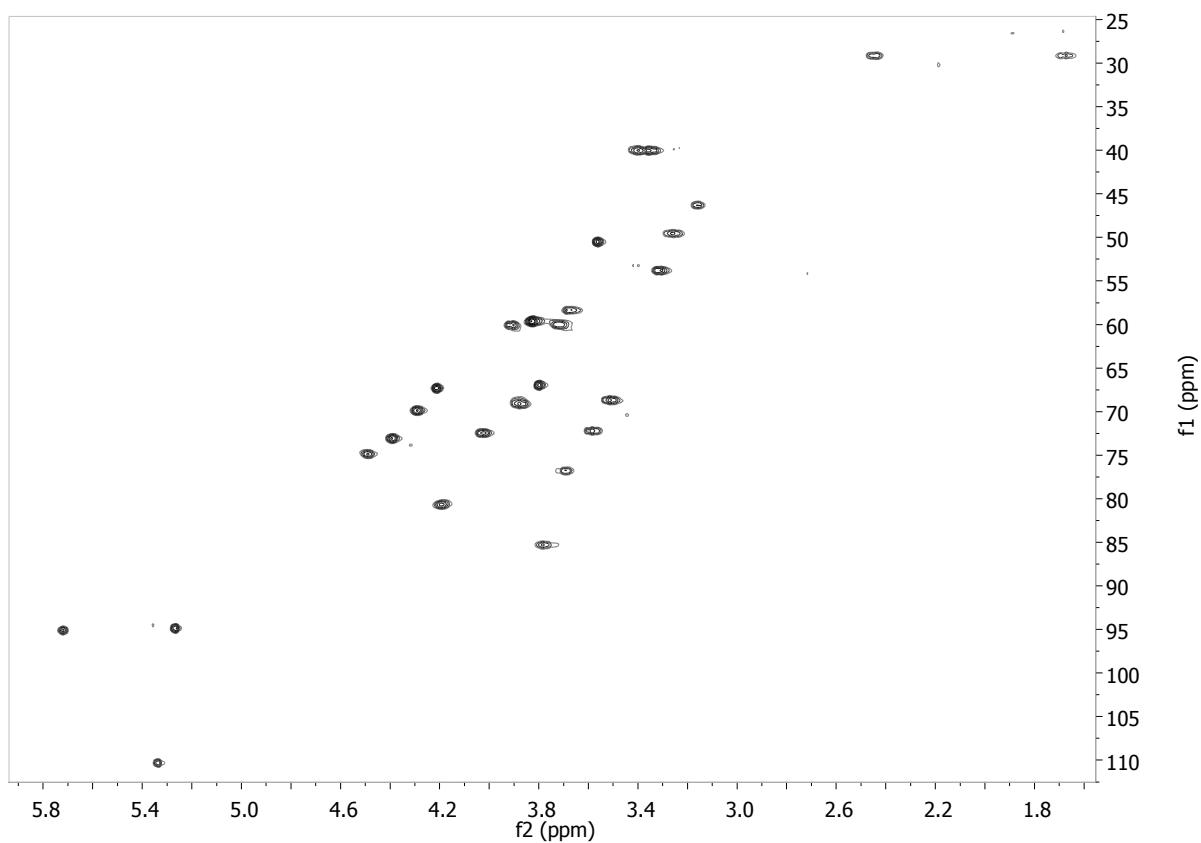

Figure 5.8b: HSQC (500 MHz, D_2O) spectrum of 3-C-azido paromomycin x 4 HFBA 11.

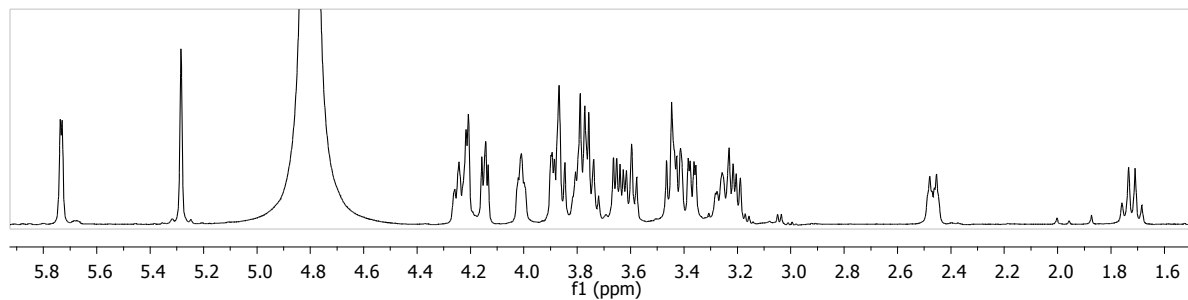

Figure 5.9a: $^1\text{H-NMR}$ (500 MHz, D_2O) spectrum of 3-C-azido ribostamycin x 3 HFBA **12**.

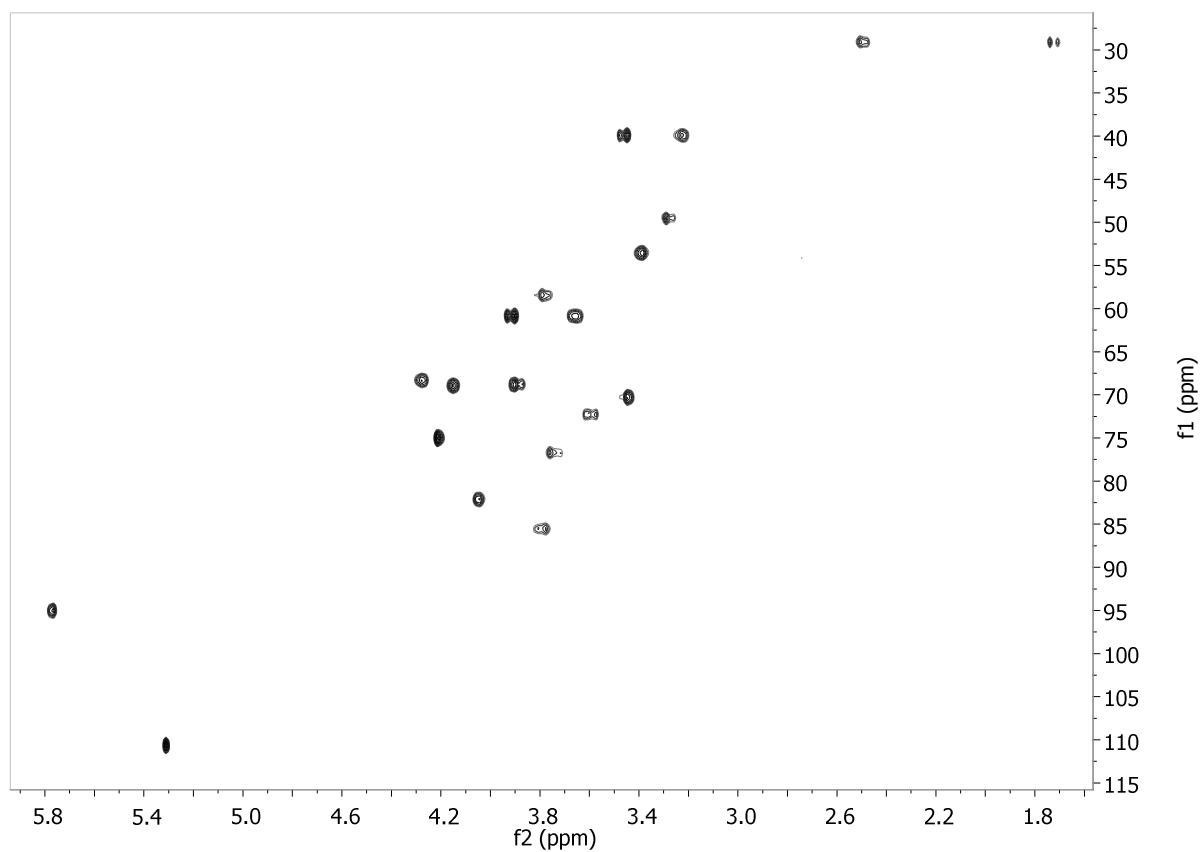

Figure 5.9b: $^1\text{H-NMR}$ (500 MHz, D_2O) spectrum of 3-C-azido ribostamycin x 3 HFBA **12**.

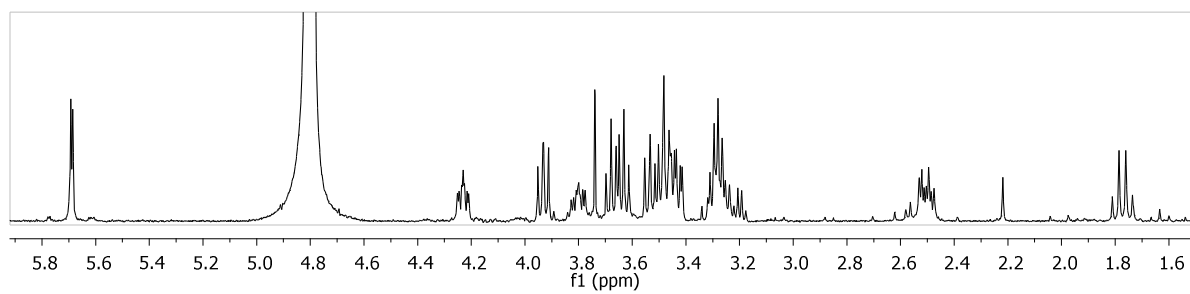

Figure 5.10a: $^1\text{H-NMR}$ (500 MHz, D_2O) spectrum of 3-C-azido neamine x 3 HFBA **9**.

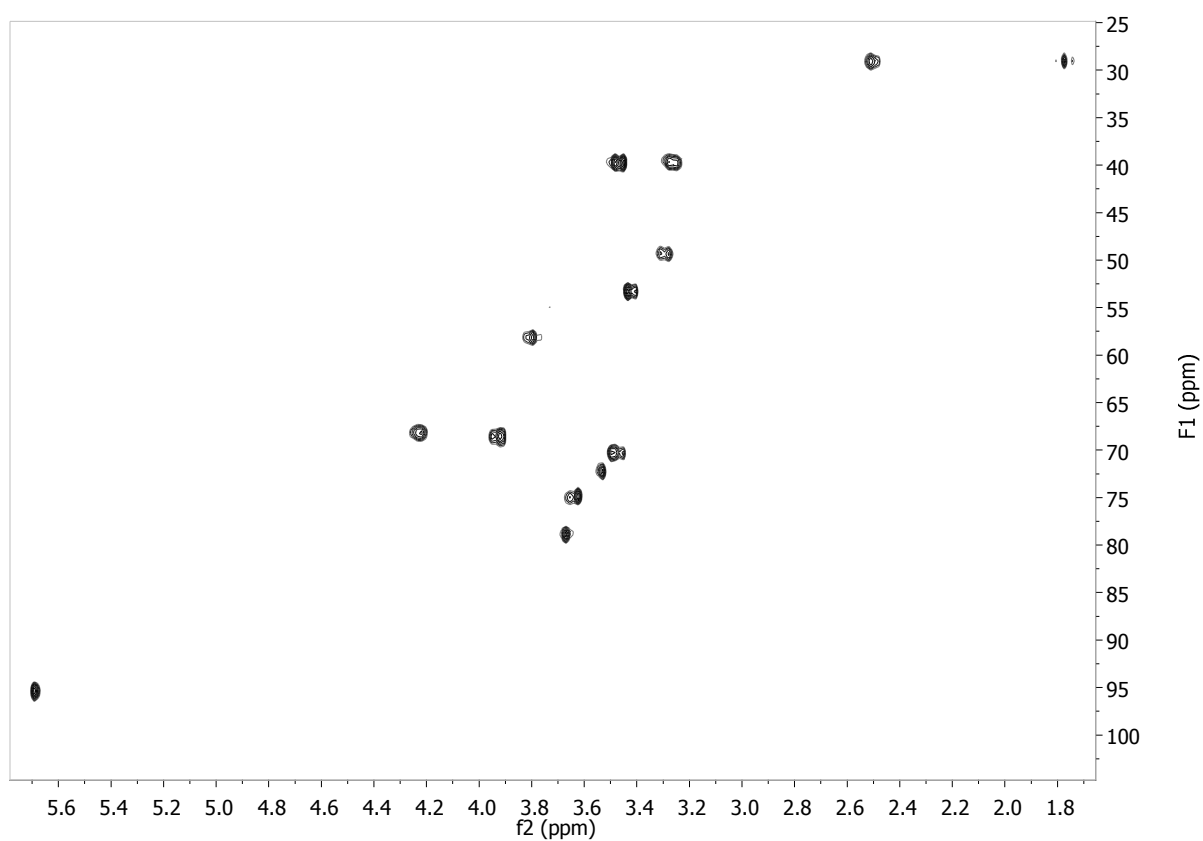

Figure 5.10b: $^1\text{H-NMR}$ (500 MHz, D_2O) spectrum of 3-C-azido neamine x 3 HFBA **9**.

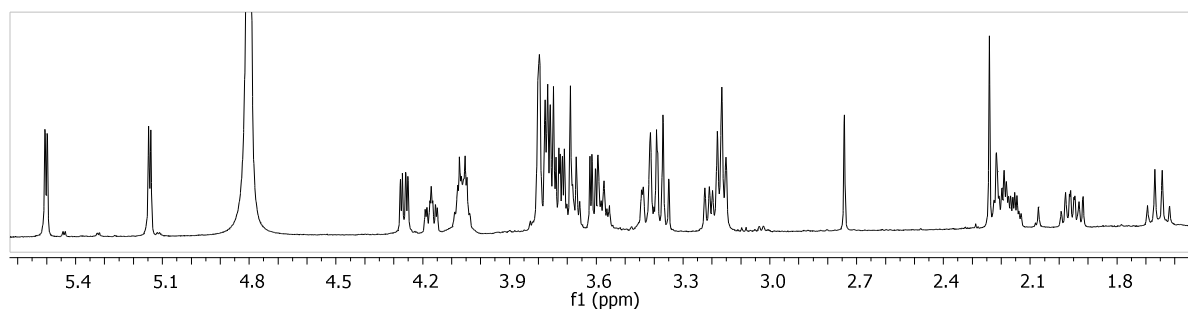

Figure 5.11a: $^1\text{H-NMR}$ (500 MHz, D_2O) spectrum of 3-C-azido amikacin x 4 HFBA **10**.

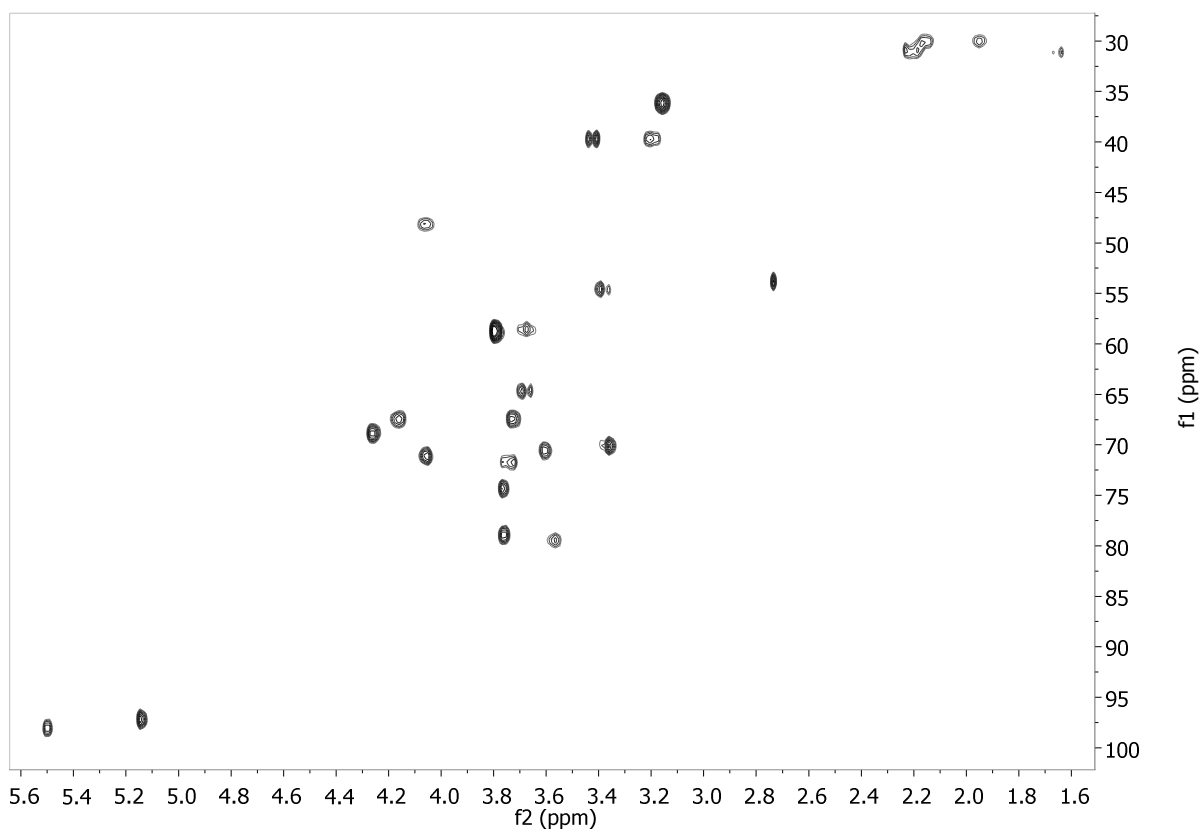

Figure 5.11b: $^1\text{H-NMR}$ (500 MHz, D_2O) spectrum of 3-C-azido amikacin x 4 HFBA **10**.

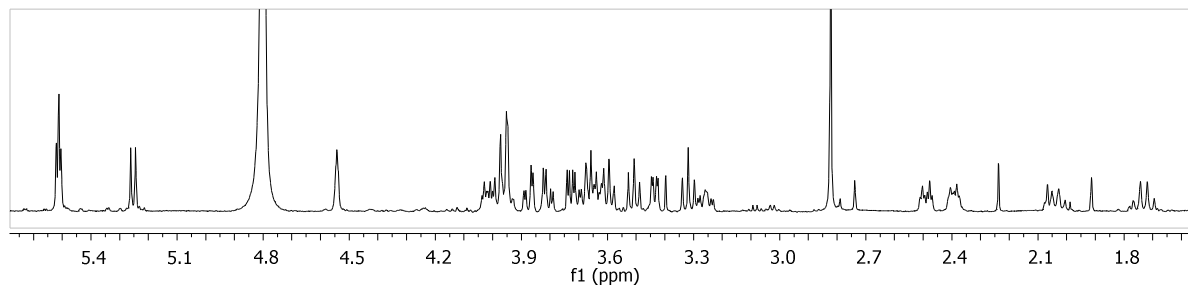

Figure 5.12a: $^1\text{H-NMR}$ (500 MHz, D_2O) spectrum of 3-C-azido apramycin x 4 HFBA **13**.

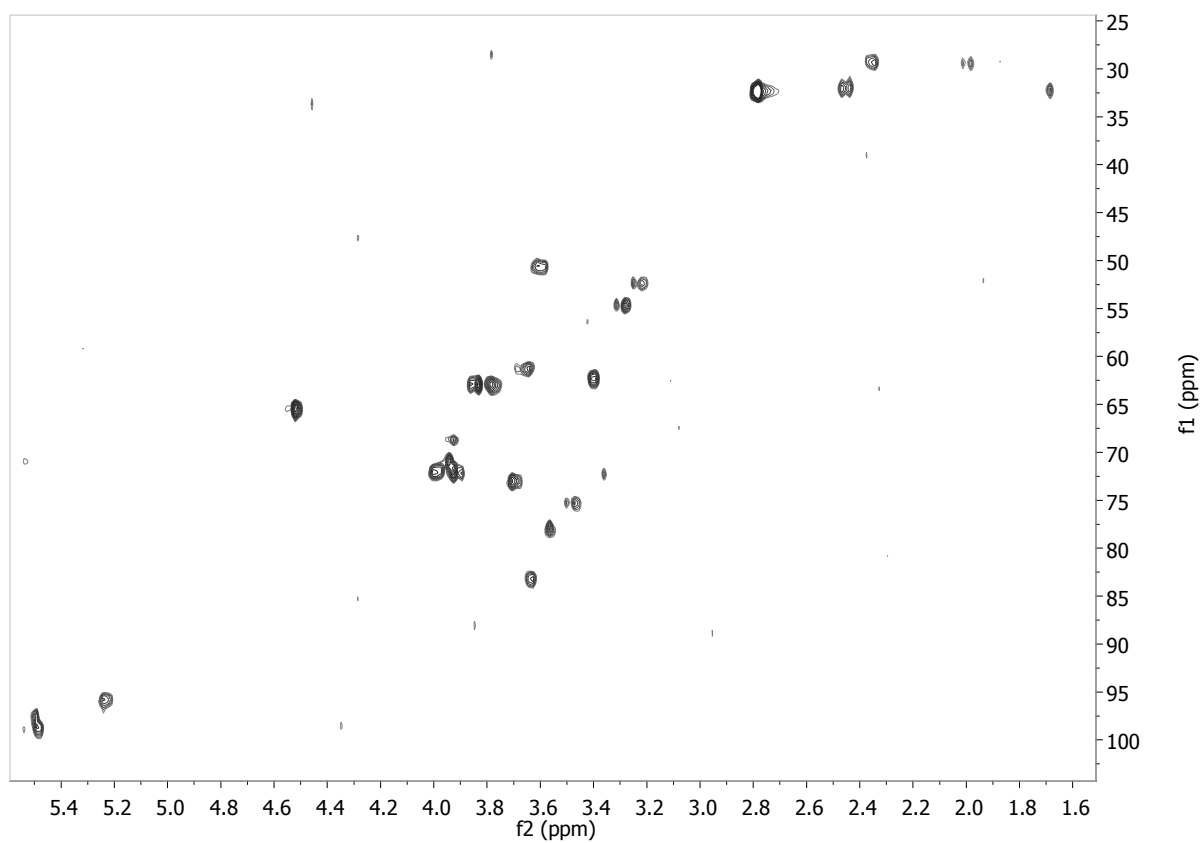

Figure 5.12b: HSQC (500 MHz, D_2O) spectrum of 3-C-azido apramycin x 4 HFBA **13**.

5.4.6 High Resolution Mass Spectrometric Analysis

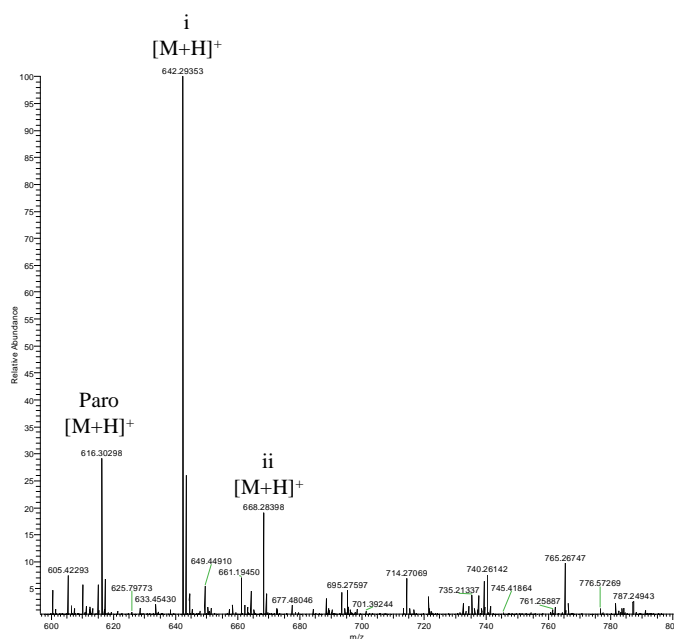

Figure 5.13: ESI-MS spectrum of reaction mixture of paromomycin (Paro) with 16 equiv. diazo-transfer reagent **7.HCl** after incubation for 18 hours at room temperature (i-ii = number of introduced azide groups).

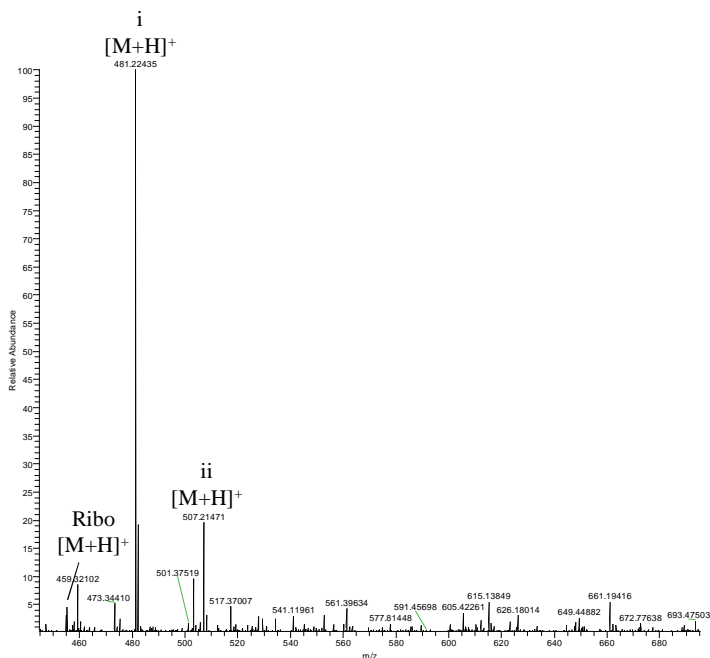

Figure 5.14: ESI-MS spectrum of reaction mixture of ribostamycin (Ribo) with 16 equiv. diazo-transfer reagent **7.HCl** after incubation for 18 hours at room (i-ii = number of introduced azide groups).

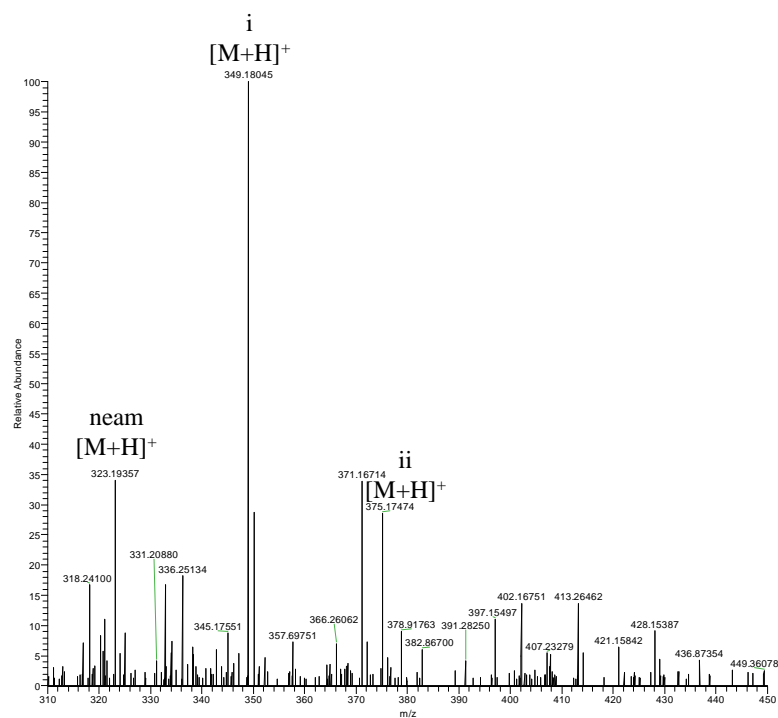

Figure 5.15: ESI-MS spectrum of reaction mixture of neamine (neam) with 16 equiv. diazo-transfer reagent **7.HCl** after incubation for 18 hours at room temperature (i-ii = number of introduced azide groups).

5.5 References

- 1 Moazed, D., Noller, H. F., Interaction of antibiotics with functional sites in 16S ribosomal RNA. *Nature* **327**, 389-394 (1987).
- 2 Fourmy, D., Recht, M. I., Blanchard, S. C., Puglisi, J. D., Structure of the A-site of *Escherichia coli* 16S ribosomal RNA complexed with an aminoglycoside antibiotic. *Science* **274**, 1367-1371 (1996).
- 3 Yoshizawa, S., Fourmy, D., Puglisi, J. D., Recognition of the codon-anticodon helix by ribosomal RNA. *Science* **285**, 1722-1728 (1999).
- 4 Cohen, M. L. Epidemiology of drug resistance: Implications for a post-Antimicrobial Era. *Science* **257**, 1050-1055 (1992).
- 5 Oulette, M., Kündig, C. Microbial multidrug resistance. *Int. J. Antimicrob. Agents* **8**, 179-187 (1997).
- 6 Davis, J. Inactivation of antibiotics and the dissemination of resistance genes. *Science* **264**, 375-382 (1994).
- 7 Zhou, J., Wang, G., Zhang, L.-H., Ye, X.-S., Modifications of aminoglycoside antibiotics targeting RNA. *Med. Res. Rev.* **3**, 279-316 (2007).
- 8 Wright, G. D., Berghuis, A. A., Mobashery, S. *Aminoglycoside antibiotics: Structure and resistance*; Rosen, B. P., Mobashery S., Eds.; Plenum Press: New York, **27** (1998).
- 9 Haddad, J., Vakulenko, S., Mobashery, S. An antibiotic cloaked by its own resistance enzyme. *J. Am. Chem. Soc.* **121**, 11922-11923 (1999).
- 10 Hanessian, S., Kornienko, A., Swayze, E. E. Probing the functional requirements of the l-haba side-chain of amikacin—synthesis, 16S A-site rRNA binding, and antibacterial activity. *Tetrahedron* **59**, 995-1007 (2003).
- 11 Alper, P. B., Hendrix, M., Sears, P. & Wong, C. H. Probing the specificity of aminoglycoside ribosomal RNA interactions with designed synthetic analogs. *J. Am. Chem. Soc.* **120**, 1965-1978 (1998).
- 12 Roestamadji, J., Grapsas, I., Mobashery, S. Loss of individual electrostatic interactions between aminoglycoside antibiotics and resistance enzymes as an effective means to overcoming bacterial drug resistance. *J. Am. Chem. Soc.* **117**, 11060-11069 (1995).
- 13 Pathak, R., Preze-Fernandez, D., Nandurdikar, R., Kalapala, S. K., Böttger, E. C., Vasella, A. Synthesis and evaluation of paromomycin derivatives modified at C(4'). *Helvetica Chimica Acta* **91**, 1533-1552 (2008).
- 14 Li, J., Chiang, F.-I., Chen, H.-N., Chang, C.-W. T. Investigation of the regioselectivity for the Staudinger reaction and its application for the synthesis of aminoglycosides with N-1 modification. *J. Org. Chem.* **72**, 4055-4066 (2007).
- 15 Lee, S. H., Cheong, C. S. Selective reactions of reactive amino groups in polyamino compounds by metal-chelated or -mediated methods. *Tetrahedron* **57**, 4801-4815 (2001).
- 16 Green, K. D., Chen, W., Garneau-Tsodikova, S. Effects of altering aminoglycoside structures on bacterial resistance enzyme activities. *Antimicrob. Agents Chemother.* **55**, 3207-3213 (2011).
- 17 Samantaray, S., Marathe, U., Dasgupta, S., Nandicoori, V. K., Roy, R. P. Peptide-sugar ligation catalyzed by transpeptidase sortase: A facile approach to neoglycoconjugate synthesis. *J. Am. Chem. Soc.* **130**, 2132-2133 (2008).

Chapter 5

- 18 Roestamadji, J., Mobashery, S. The use of neamine as a molecular template: Inactivation of bacterial antibiotic resistance enzyme aminoglycoside 3'-phosphotransferase type IIa. *Bioorg. Med. Chem. Lett.* **8**, 3483-3488 (1998).
- 19 Goddard-Borger, E. D., Stick, R. V. An Efficient, Inexpensive and Shelf-Stable Diazotransfer Reagent: Imidazole-1-sulfonyl Azide Hydrochloride. *Org. Lett.* **9**, 3797-3800 (2007).
- 20 Schoffelen, S., van Eldijk, M. B., Rooijackers, B., Raijmakers, R., Heck, A. J. R., Hest, J. C. M. Metal-free and pH-controlled introduction of azides in proteins. *Chem. Sci.* **2**, 701-705 (2011).
- 21 Botto, R. E., Coxon, B., Nitrogen-15 nuclear magnetic resonance spectroscopy of neomycin B and related aminoglycosides. *J. Am. Chem. Soc.* **105**, 1021-1028 (1983).
- 22 Sawa, M., Hsu, T.-L., Itoh, T., Sugiyama, M., Hanson, S. R., Vogt, P. K., Wong, C.-H. Glycoproteomic probes for fluorescent imaging of fucosylated glycans in vivo. *Proc. Natl. Acad. Sci. U.S.A.* **103**, 12371-12376 (2006).
- 23 Rostovtsev, V. V., Green, L. G., Fokin, V. V., Sharpless, K. B. A stepwise *Huisgen* cycloaddition process: Copper(I)-catalyzed regioselective ligation of azides and terminal Alkynes. *Angew. Chem. Int. Ed.* **41**, 2596-2599 (2002).
- 24 Ariza, X., Urpi, F., Vilarrasa, J. A practical procedure for the preparation of carbamates from azides. *Tetrahedron Lett.* **40**, 7515-7517 (1999).
- 25 Park, W. K. C., Auer, M., Jaksche, H., Wong, C.-H. Rapid combinatorial synthesis of aminoglycoside antibiotic mimetics: Use of a polyethylene glycol-linked amine and a neamine-derived aldehyde in multiple component condensation as a strategy for the discovery of new inhibitors of the HIV RNA Rev responsive element. *J. Am. Chem. Soc.* **118**, 42, 10150-10155 (1996).

Chapter 6

Summary • Samenvatting •

Streszczenie • Zusammenfassung

6.1 Summary

Since the mechanism of bacterial resistance against neamine antibiotics is well understood, modification of aminoglycosides is becoming a promising tool to overcome antibacterial resistance. However, these natural products are structurally complex and exhibit several chemical equivalent groups with similar reactivity. Therefore, modification of a single position in these molecules is difficult or not realizable at all. Thus, the transformation of such natural products often results in a mixture of inseparable derivatives. To obtain a structurally complex natural compound modified at a single position, cumbersome and time-consuming part- or total synthesis is required, including the introduction and removal of covalent protective groups. Especially, the selective modification of antibiotics based on aminoglycoside can require more than 20 synthetic steps employing conventional synthesis. To overcome these difficulties and facilitate the development of new antibiotics, in this thesis two conceptually new methods were presented enabling regioselective modifications of neamine antibiotics in a single step.

The first strategy (chapters one, three and four) is based on the application of non-covalent protective groups, so called **aptameric protective groups (APGs)**, which are based on short RNA sequences. In contrast to covalent protective groups, APGs can shield several functionalities of a structurally complex compound at the same time by non-covalent interactions, while chemically equivalent groups not in contact with the APG can be reacted regioselectively (Scheme 6.1). In **chapter 2** the efficient use of RNA sequences as APGs was presented for the highly regioselective derivatization of complex neamine antibiotics bearing several functional groups with similar reactivity. This was successfully demonstrated for aminoglycoside antibiotics neomycin B and paromomycin with three different RNA sequences. These aminoglycosides were modified employing acylation reaction using different *N*-hydroxysuccinimide esters proceeding with excellent regioselectivities up to 98 %. With these results it was proven for the first time that RNA sequences can be applied as non-covalent protective groups. Another important result in the first chapter was the finding that the same RNA aptamers can be applied as APGs for compounds with a similar pharmacophore. Thus, RNA sequences selected for the antibiotic neomycin B were successfully applied as non-covalent protective groups for the structurally related aminoglycoside paromomycin.

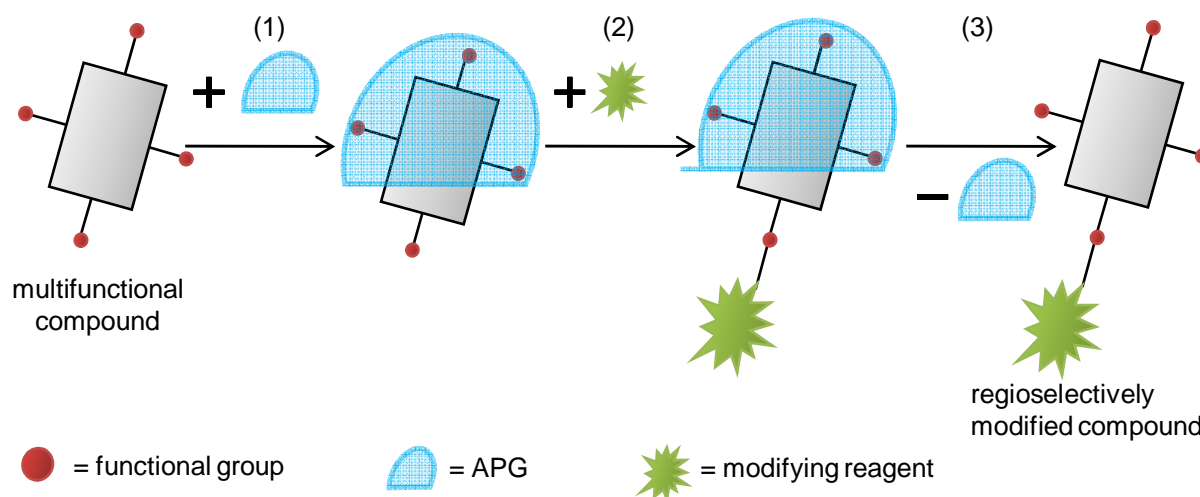

Scheme 6.1: Site-specific modification of a multifunctionalized compound employing non-covalent aptameric protective groups: Introduction of protective group (1), regioselective transformation (2), removal of protective group (3).

However, considering that RNA sequences can exhibit several binding sites with different protection modes for the antibiotic, acetylation of neomycin B using NHS esters can result in a mixture of regioisomers and thereby limiting the regioselectivity. Therefore, the mode of action of RNA sequences acting as APGs needed to be elucidated. The study presented in **chapter 3** demonstrated that the applied APGs exhibit two different binding sites with different protection modes for neomycin B resulting in two different monoacetylated antibiotic derivatives after transformation. However, due to the fact that both binding sites have different affinities to the aminoglycoside, the reaction conditions especially the aptamer/antibiotic ratio and the reaction time were successfully adjusted in order to obtain one of these isomers in excellent regioselectivity. Moreover, our investigations showed that **Isothermal Titration Calorimetry (ITC)** measurements are a useful tool to estimate the applicability of RNA aptamers as APGs. This holds especially true when **SELEX** experiments will be employed in the future for generation of APGs for new compounds to be modified from which the structure of the RNA-compound complex is unknown. Finally, it was shown that regioselective derivatization of neomycin B in presence of APGs can also be performed at higher temperature (up to 50 °C) demonstrating the stability of these protective groups.

To further establish APGs as a general tool in organic synthesis, it was proven that APGs tolerate a wide range of modifications including transformations at different positions of neamine antibiotics neomycin B and paromomycin. In **chapter 4**, several reactions were

tested regarding their applicability in the context of APGs. Four different reactions, namely acylation, thiolation, urea bond formation and azide introduction were successfully applied for the transformation of the antibiotics in presence of APG using 4-sulfo-*tetra*-phenyl (STP) ester, 2-iminothiolane, diverse isocyanates and imidazole-1-sulfonyl azide, respectively. Additionally, it was demonstrated that APGs allow the application of positively and negatively charged reagents for the modification of neomycin B and that transformations can also be performed under basic conditions reaching excellent regioselectivities. Finally, it was presented that the application of the same APG allows regio- and chemoselective monofunctionalization of two different amino groups and difunctionalization in both positions of the antibiotics employing different reagents. According to the results presented in chapters 2, 3 and 4, APGs merit consideration as a new valuable concept in organic synthesis as they can be evolved for a large variety of target molecules bearing different structural features and their generation relies on a well-established *in vitro* evolution process. Moreover, APGs based on RNA molecules will become an indispensable and effective tool for the derivatization of complex natural products and vastly simplify drug development.

Besides using APGs to obtain selectively modified natural products, other methods were explored for the efficient derivatization of complex molecules. In **chapter 5**, a regioselective one-step modification of a specific amino group within neamine antibiotics was developed avoiding any protective group chemistry. The mentioned functional group is located at the core structure of neamine antibiotics, i.e. the streptamine scaffold, which is a target for several enzymes in resistant bacteria erasing the antibacterial activity of these therapeutics. The modification of such positions is still a challenge and requires multi-step synthesis. Therefore, a new method was developed to transform this amine in a single step on the level of the natural compounds using the diazo-transfer reagent imidazole-1-sulfonyl azide hydrochloride. Thus, an azide was introduced in C3 position of the 2-desoxystreptamine ring in six different neamine antibiotics bearing four to six amines reaching regioselectivities up to >99 %. It was demonstrated that the reactivity of the amino groups within these aminoglycosides can be controlled by addition of catalyst and altering the pH. Furthermore, it was elucidated that the key to this specific transformation of the mentioned amine is its low pK_a value.

Figure 6.1 summarizes the antibiotics that were all modified in as single chemical transformation and the relevant modification sites are indicated. All the different strategies and reactions described in this thesis have in common that they keep the synthetic efforts for the selective modification of natural products at a minimum. They even force this effort to the

extreme of a single-step modification. The results obtained in this thesis will help to build libraries of very complex molecules for drug screening. Moreover, this work will enable more efficient synthesis of natural product derivatives and will allow the development of new promising antibiotics overcoming antibacterial resistance.

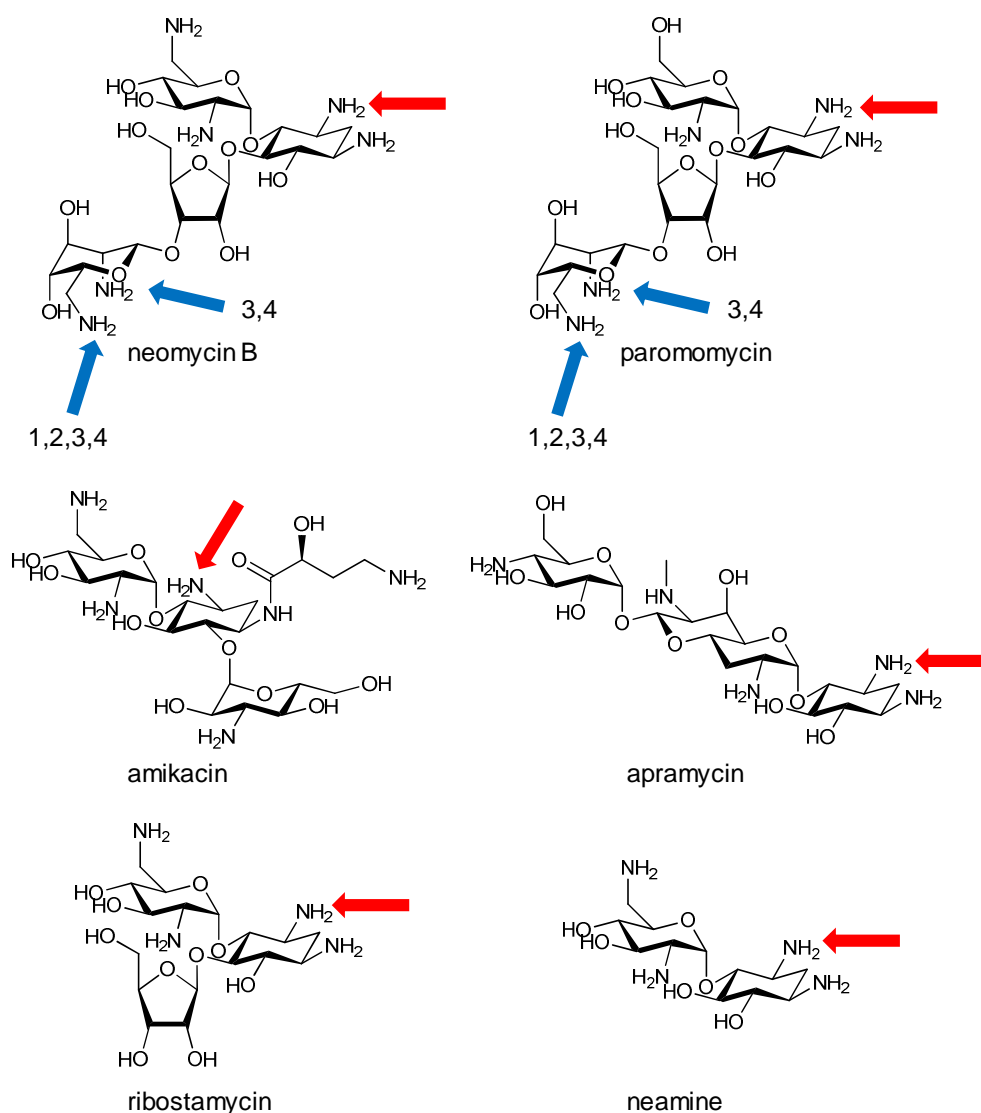
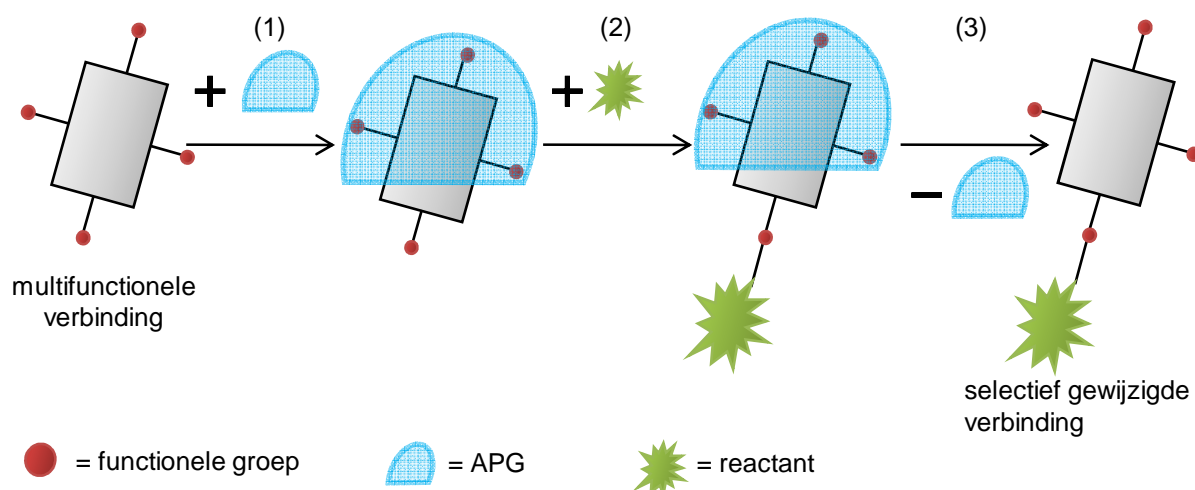

Figure 6.1: Molecular structures of neamine antibiotics modified regioselectively in a single synthetic step. Arrows indicate the modification sites of these aminoglycosides transformed using APG-strategy (blue) and selective azide introduction (red). Numbers indicate the performed transformations in presence of APGs: acylation (1), thiolation (2), urea formation (3), azide introduction (4).

6.2 Samenvatting

Omdat het mechanisme voor de resistentie van bacterien tegen neamines bekend is wordt het modificeren van aminoglycosiden een veelbelovende methode voor de bestrijding van bacteriële resistentie. Echter, deze natuurlijke producten hebben een complexe structuur en hebben verschillende chemisch equivalente groepen met gelijke reactiviteit. Daarom is modificatie van een enkele positie moeilijk of niet realiseerbaar. Zodoende resulteren deze transformaties vaak in een mengsel van onscheidbare derivaten. Om een complex product zoals deze te verkrijgen is een tijd en arbeids intensieve deel of totaal synthese nodig met introductie en verwijdering van covalente beschermgroepen. Vooral de selectieve modificatie van antibiotica gebaseerd op aminoglycosiden zoals het commerciële antibioticum neomycin B vereist meer dan 20 synthetische stappen wanneer men conventionele methoden toepast. Om deze problemen het hoofd te bieden en om de ontwikkeling van nieuwe antibiotica te vergemakkelijken worden in dit proefschrift twee nieuwe strategieën gepresenteerd die de regioselectieve modificatie van neamine antibiotica mogelijk maken in een enkele stap.

De eerste methode (Hoofdstuk 2,3 en 4) is gebaseerd op het gebruik van niet covalente beschermgroepen bestaande uit RNA, zogenoemde **aptameric protective groups (APGs)**. In tegenstelling tot covalente beschermgroepen kunnen APGs verschillende functionele groepen van een complexe structuur tegelijkertijd afschermen, terwijl chemisch equivalente groepen die niet in contact komen met het aptameer regioselectief gereageerd kunnen worden (Schema. 6.1). In **hoofdstuk 2** wordt het gebruik van RNA als APGs gedemonstreerd voor de regiospecifieke modificatie van complexe neamine antibiotica. Deze methode is succesvol toegepast voor zowel neomycin B alswel parmomycin, waarbij gebruik gemaakt is van drie verschillende strengen RNA. Beide aminoglycosiden zijn gemodificeerd door middel van een acylatie reactie met verschillende **N-hydroxysuccinimide (NHS)** esters en vertonen excellente regioselectiviteit tot 97%. Hiermee is voor het eerst bewezen dat RNA gebruikt kan worden als beschermgroep. Verder is ook gebleken dat dezelfde RNA aptameer gebruikt kan worden voor verschillende moleculen met eenzelfde pharmacophore.



Schema 6.1: Locatiespecifieke modificatie van complexe verbindingen met gebruik van niet covalente beschermgroepen: Introductie van beschermende groep (1), regiospecifieke transformatie (2), verwijdering van de beschermende groep (3).

Echter, wanneer rekening gehouden wordt met het feit dat RNA verschillende bindingsplaatsen heeft en op verschillende manieren kan beschermen, kan het gebruik van NHS ester resulteren in een mengsel van regioisomeren, wat de regioselectiviteit beperkt. Daarom moet de rol van het RNA als APG beter verklaart worden. Het onderzoek gepresenteerd in **hoofdstuk 3** demonstreert dat de gebruikte APGs twee verschillende bindingsplaatsen hebben met verschillende bescherm functies, wat resulteert in twee verschillende mono-geacylerde neomycin B derivaten. Echter, omdat de bindingsplaatsen verschillende affiniteit hebben voor de aminoglycosiden, kunnen de reactie condities zo gekozen worden dat een van beide isomeren alsnog met een excellente regioselectiviteit verkregen word. Verder heeft ons onderzoek aangetoond dat isothermal titration calorimetry metingen goed gebruikt kunnen worden om toepasbaarheid van een RNA aptameer als APG in te schatten. Dit is gaat ook op wanneer in toekomst de SELEX methode gebruikt gaat worden voor de selectie van onbekende APGs voor nieuwe verbindingen. Tenslotte is ook aangetoond dat de derivatisering van neomycin B in het bijzijn van APGs ook gedaan kan worden op hogere temperatuur (tot 50 °C), wat de stabiliteit van deze beschermgroepen bewijst.

Om APGs verder als algemene methode in organische synthese te introduceren is bewezen dat deze een grote variëteit aan modificaties en transformaties tolereren op verschillende posities in neomycin B en paromomycin. In **hoofdstuk 4** zijn verschillende reacties getest voor hun

gebruik in combinatie met APGs. Vier verschillende reacties, te weten acylatie, thiolatie, urethaan formatie en azide productie, zijn succesvol gebruikt voor de modificatie van antibiotica in de aanwezigheid van APG met respectievelijk sulfo-*tetra*-phenyl (STP) ester, 2-iminothiolane, diverse isocyanaten en imidazole-1-sulfonyl azide. Verder is aangetoond dat APGs gebruikt kunnen worden in combinatie met zowel negatief als positief geladen reagentia voor modificatie van neomycin B en dat transformaties in de aanwezigheid van APGs gedaan kunnen worden onder basische condities met excellente regioselectiviteit. Tenslotte is bewezen dat gebruik van APGs het mogelijk maakt om regio- en chemoselectief twee verschillende amino groepen gecontroleerd enkel of dubbel te functionaliseren, wanneer de reactie uitgevoerd wordt met verschillende reagentia. De gepresenteerde resultaten geven duidelijk aan dat APGs gebruikt kunnen worden als nieuw concept in de organische chemie, zeker daar ze gemakkelijk geselecteerd kunnen worden voor een groot scala aan doel moleculen die verschillende structurele functies hebben. Bovendien zullen APGs gebaseerd op RNA aptameren een onmisbare en effectieve methode vormen voor de derivatisering van complexe natuur producten en zal hierdoor medicijn ontwikkeling snel versimpelen.

Naast het gebruik van APGs voor het maken van selectief gemodificeerde natuurlijke producten zijn er ook andere methoden ontwikkeld voor het efficiënt derivatiseren van complexe moleculen. In **hoofdstuk 5** is een regioselectieve een-staps modificatie van een specifieke amino groep aan neamine antibiotica ontwikkeld zonder gebruik te maken van beschermgroepen. Deze functionele groep bevindt zich in de kern structuur van deze antibiotica, d.w.z. de streptamine eenheid, wat het doel is van verschillende enzymen in resistente bacteriën die de anti-bacteriële teniet doen. De modificatie van dergelijke posities is nog steeds een uitdaging en benodigd normaliter meerdere synthetische stappen. Zodoende is een nieuwe methode ontwikkeld voor transformatie van deze amine in een enkele stap door gebruik te maken van diazo overdrachts reagentia. Hierdoor is een azide groep geïntroduceerd op de C₃ positie van de 2-desoxystreptamine ring in zes verschillende neamine antibiotica met een regioselectiviteit van meer dan 99%. Er is aangetoond dat de reactiviteit van de amino groepen in deze antibiotica gecontroleerd kan worden door toevoeging van een catalysator en verandering van de pH. Daarnaast is uitgevonden dat de sleutel tot deze specifieke transformatie ligt in de lage pK_a waarden van de genoemde amino groep.

Figuur 6.1 geeft een overzicht van alle antibiotica die gemodificeerd zijn in een enkele stap met de bijbehorende positie. Alle verschillende methoden en reacties in dit proefschrift hebben gemeen dat ze de synthetische complexiteit voor selectieve modificering tot een

minimum beperken. Dit wordt tot het extreme gedreven, een een-staps modificatie. De resultaten gegeven in dit proefschrift zullen helpen bij de opbouw van een bibliotheek van zeer complexe moleculen voor medicijn screening, zal efficiëntere methoden voor de synthese van natuur product derivaten mogelijk maken en zal het mogelijk maken om nieuwe antibiotica te ontwikkelen om bacteriële resistentie het hoofd te bieden.

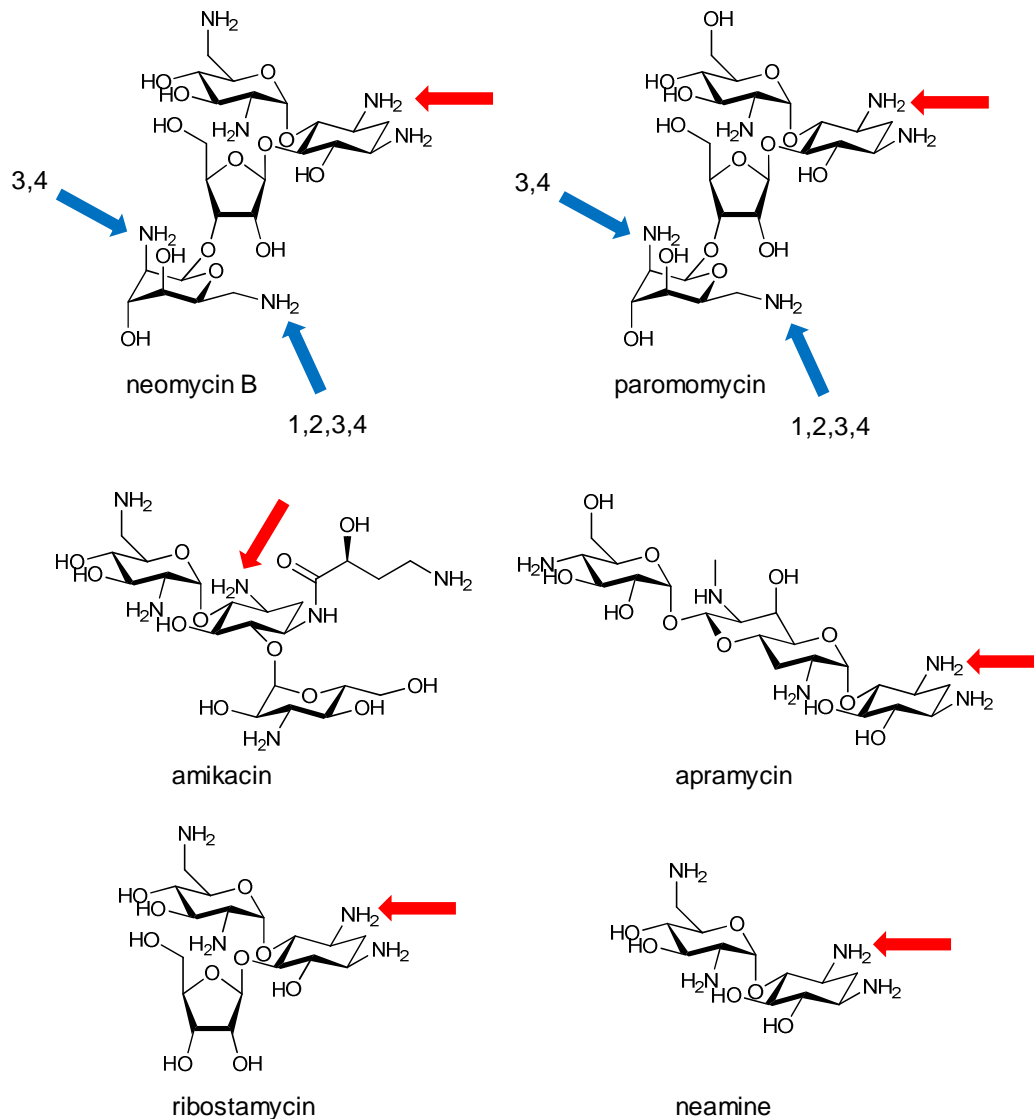

Figuur 6.1: Structuren van neamine antibiotica die regioselectief gemodificeerd zijn met een enkele synthetische stap. Pijlen geven modificatie plaats aan van aminoglycosiden getransformeerd met APG-strategie (blauw) en selectieve azide introductie (rood). Nummers geven de uitgevoerde transformaties aan in de aanwezigheid van APGs: acylatie (1), thiolatie (2), urea formatie (3), azide introductie (4).

6.3 Streszczenie

Synteza zmodyfikowanych aminoglikozydów staje się ważnym narzędziem w walce z lekoopornymi bakteriami, co wynika ze zrozumienia mechanizmów oporności przeciwko antybiotykom neaminowym. Niestety, te naturalne produkty mają bardzo złożoną strukturę, która zawiera wiele chemicznie równocennych grup funkcyjnych, wykazujących podobną reaktywność. Z tego powodu selektywna modyfikacja wybranej grupy jest trudna, a w wielu przypadkach niemożliwa. Totalna synteza złożonych związków naturalnych jest czasochłonna i wymaga zastosowania grup zabezpieczających. W szczególności selektywna modyfikacja antybiotyków aminoglikozydowych, takich jak handlowo dostępna neomycyna B, wymaga ponad 20 reakcji w syntezie konwencjonalnej. W niniejszej pracy opisano metody pozwalające na przezwycięzenie tych trudności i ułatwienie opracowywania nowych antybiotyków dzięki regioselektywnym modyfikacjom antybiotyków neaminowych w pojedynczej reakcji.

Pierwsza strategia (opisana w rozdziałach 2, 3 i 4) opiera się na zastosowaniu niekonwalencyjnych grup zabezpieczających, tak zwanych aptamerowych grup zabezpieczających (*ang.* aptameric protective groups, APG), które wykorzystują krótkie sekwencje RNA. W odróżnieniu od kowalencyjnych grup zabezpieczających, APG mogą osłaniać kilka grup funkcyjnych w pojedynczym związku w tym samym czasie, pozwalając na regioselektywną transformację pozostałych grup (Schemat 6.1). **Rozdział 2** opisuje efektywne użycie sekwencji RNA jako APG do regioselektywnej modyfikacji złożonych antybiotyków neaminowych, co zostało wykazane na przykładzie neomycyny B i paromomycyny z trzema różnymi sekwencjami RNA. Antybiotyki te zostały zmodyfikowane poprzez reakcję acylowania z regioselektywnością dochodzącą do 97%. Te wyniki pokazały po raz pierwszy że sekwencje RNA mogą być zastosowane jako niekowalencyjne grupy zabezpieczające. Ponadto, wykazano również że te same aptamery RNA mogą służyć jako APG dla różnych związków posiadających podobny farmakofor.

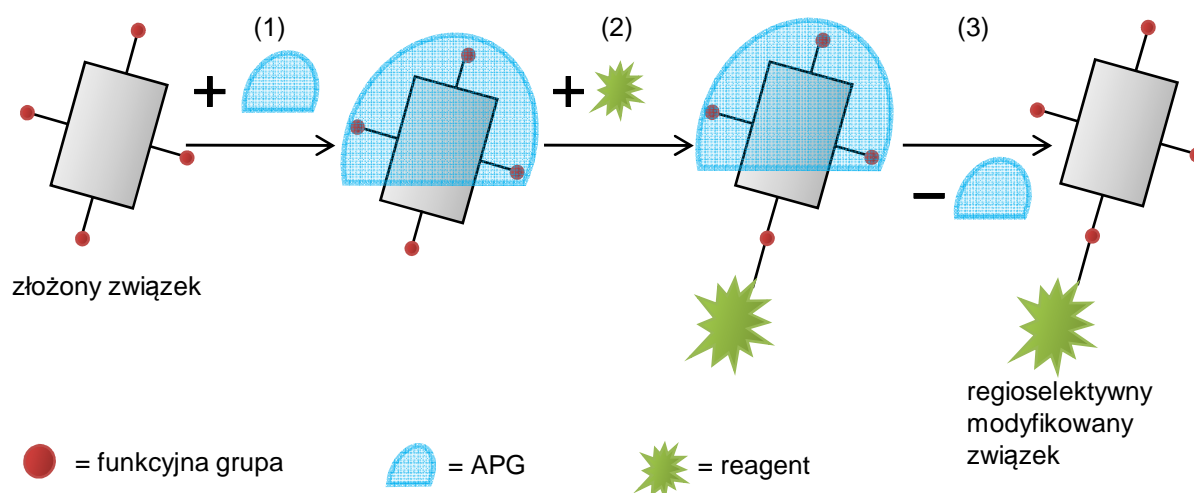

Schemat 6.1: Specyficzna modyfikacja w złożonej związku z wykorzystaniem niekonwalencyjnych grup zabezpieczających (APGs): Wprowadzenie grupy zabezpieczającej (1), regioselektywną transformacją (2), Usunięcie grupy zabezpieczającej (3).

Czynnikiem ograniczającym regioselektywność reakcji opisanej powyżej jest fakt, że sekwencje RNA mogą oddziaływać z neomycyną B na kilka sposobów. Badania opisane w **rozdziale 3** wykazały, że użyte APG wiążą neomycynę B na dwa sposoby, co prowadzi do uzyskania dwóch produktów w wyniku reakcji acylowania. Różnica w energii dla tych dwóch oddziaływań pozwoliła na optymalizację warunków reakcji i podniesienie selektywności. Nasze badania wykazały również, że izotermalne miareczkowanie kalorymetryczne jest dogodnym narzędziem do oszacowania przydatności RNA jako APG. Wykazano ponad to, że modyfikacja neomycyny B w obecności APG może być prowadzona w wyższych temperaturach (50 °C), co demonstruje wysoką stabilność tych grup zabezpieczających.

W celu dalszego wykazania szerokiego pola zastosowań dla APG, przeprowadzono badania nad ich użyciem w reakcjach antybiotyków modyfikowanych w różnych pozycjach, opisane w **rozdziale 4**. Cztery różne reakcje zostały użyte do modyfikacji neomycyny B i jej analogów w obecności APG. Wyniki tych badań potwierdzają, że użycie APG, przedstawione w rozdziałach 2-4, zasługuje na uwagę jako nowy koncept w syntezie organicznej, pozwalający na selektywną modyfikację związków o bardzo złożonej strukturze.

Kolejną metodą, przedstawioną w **rozdziale 5**, pozwala uniknąć użycia jakichkolwiek grup zabezpieczających w reakcji modyfikacji szczególnej grupy aminowej. Grupa ta ulokowana jest w rdzeniu struktury antybiotyków neaminowych, czyli w szkielecie streptaminy. Szkielet

ten jest celem ataku kilku enzymów odpowiedzialnych u bakterii za lekooporność. Modyfikacja wspomnianej grupy aminowej wciąż stanowi wyzwanie i wymaga długiej syntezy. Dlatego opracowaliśmy nową metodę przekształcania tej grupy w pojedynczej reakcji poprzez przekształcenie jej w grupę azydkową. Reakcja ta została przeprowadzona na sześciu antybiotykach z regioselektywnością dochodzącą do 99%. Wykazano również że selektywność ta może być kontrolowana przez dodatek katalizatorów oraz zmianę pH.

Schemat 6.2 podsumowuje antybiotyki które udało nam się zmodyfikować w pojedynczej reakcji. Efekty uzyskane w tej pracy pozwolą na stworzenie bibliotek anytbiotyków i rozszerzą wachlarz metod sotsowanych w syntezie antybiotyków.

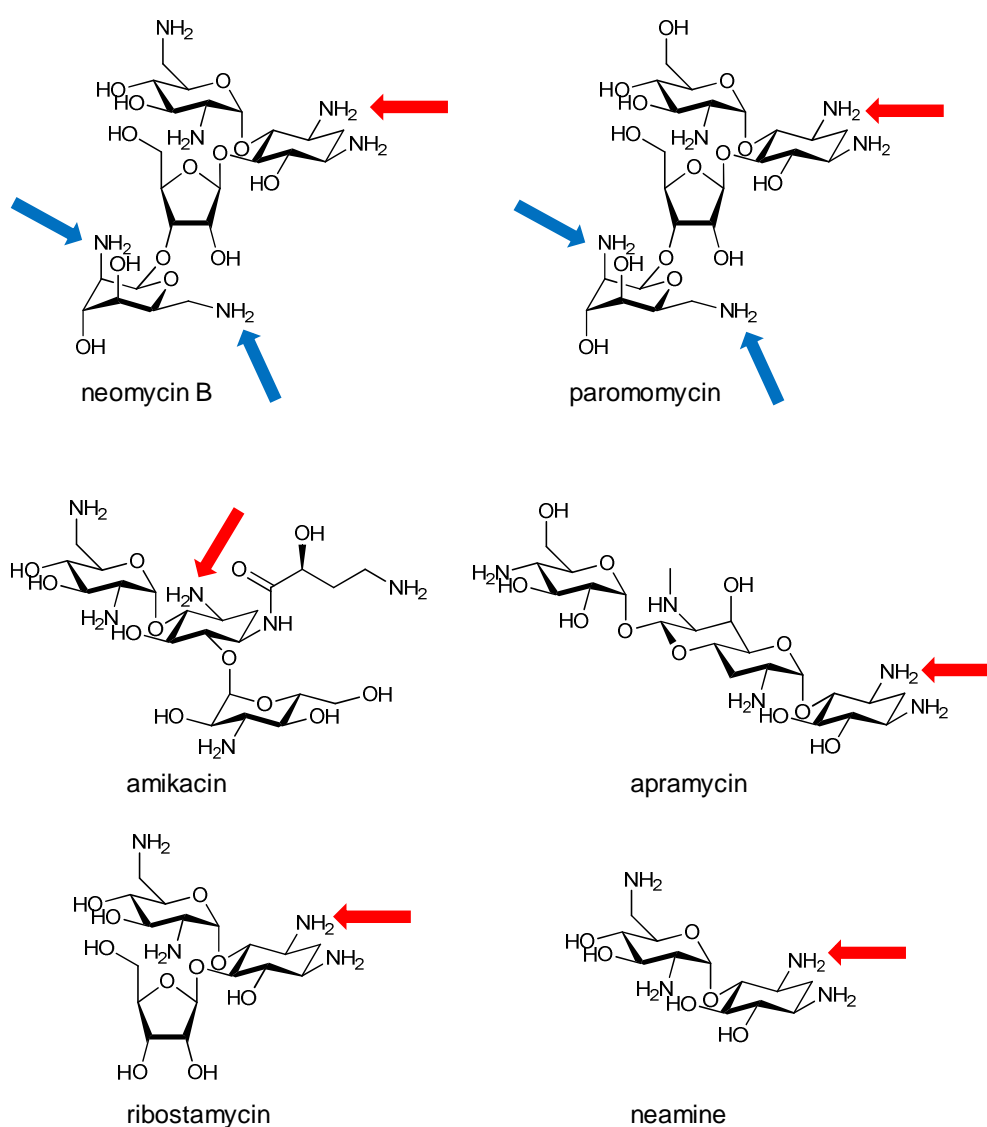

Schemat 6.2: Podsumowuje antybiotyki które udało nam się zmodyfikować w pojedynczej reakcji; miejsca modyfikacji zaznaczone są strzałkami; miejsca modyfikacji zaznaczone są strzałkami.

6.4 Zusammenfassung

Seitdem der Mechanismus der bakteriellen Resistenz verstanden ist, werden Antibiotika, die auf Neamin-Aminoglykosiden basieren, strukturell verändert (modifiziert), um die antibakterielle Resistenz aufzuheben. Aber aufgrund dessen, dass diese strukturell komplexen Naturprodukte eine Vielzahl an funktionellen Gruppen besitzen, die eine ähnliche oder gleiche Reaktivität aufweisen, ist eine selektive Modifizierung einer bestimmten Gruppe sehr schwierig oder noch nicht realisierbar. Oft resultiert die Reaktion dieser Naturprodukte mit einem Reaktanten in einem nicht auftrennbaren Gemisch an Derivaten. Um ein komplexes Molekül zu erhalten, das nur an einer Molekülseite verändert ist, ist eine zeitaufwendige und teure Totalsynthese notwendig. Zum Beispiel benötigt die Modifizierung des Aminoglykosid-Antibiotikum Neomycin B 20 synthetische Stufen, wenn ein konventioneller Syntheseweg verwendet wird, in der kovalente Schutzgruppen verwendet werden. Das entspricht einem Zeitaufwand von bis zu 2 Jahren. Um diese Schwierigkeiten zu umgehen und die Entwicklung neuer Antibiotika basierend auf komplexen Naturprodukten zu beschleunigen, wurden im Verlauf dieser Doktorarbeit zwei neue Konzepte vorgestellt, die regioselektive Modifizierungen von Neamin-Antibiotika in einer einzigen Stufe ermöglicht.

Die erste Strategie (Kapitel 2, 3 und 4) basiert auf der Verwendung von nicht-kovalenten Schutzgruppen, den sogenannten Aptamer-Schutzgruppen (engl.: **apatmeric protective groups**, APGs), die aus kurzen RNA Sequenzen bestehen. In Gegensatz zu kovalenten Schutzgruppen können APGs gleichzeitig mehrere funktionelle Gruppen eines komplexen Moleküls schützen, während Molekülgruppen, die nicht mit der Schutzgruppe in Wechselwirkung treten, in einer Reaktion regioselektiv umgesetzt werden können (Schema 6.1). Im **zweiten Kapitel** wird die hohe Effizienz der APGs gezeigt, indem sie als Schutzgruppe für aminoglykosidische Antibiotika verwendet werden, um diese einer regioselektiven Modifizierung zu unterziehen. In diesem Zusammenhang wurden drei verschiedene RNA Sequenzen als APGs erfolgreich eingesetzt, um die Antibiotika Neomycin B und Paromomycin selektiv umzusetzen. Als Reaktion für die Modifizierung dieser Aminoglykoside wurde die Acylierung von Aminogruppen mit aktivierten Estern (*N*-Hydroxysuccinimidester) gewählt. In Gegenwart von den APGs reagierte lediglich eine von bis zu sechs möglichen Aminogruppen dieser Antibiotika. An dieser Stelle muss betont werden, dass die Verwendung von APGs eine Regioselektivität von bis zu 98 % und einem Umsatz von 83 % ermöglichen. Darüberhinaus zeigt diese Studie zum ersten Mal, dass RNA Moleküle sich als nicht-kovalente Schutzgruppen eignen, um strukturell komplexe

Naturprodukte zu modifizieren. Ein weiteres Resultat, das im gleichen Kapitel präsentiert wurde, ist, dass APGs für verschiedene Antibiotika von ähnlicher molekularer Struktur verwendet werden können. Daher wurden RNA-Sequenzen, die für Neomycin B evolviert wurden, auch als APGs für das Antibiotikum Paromomycin erfolgreich eingesetzt, das eine ähnliche Struktureinheit besitzt (Neamin).

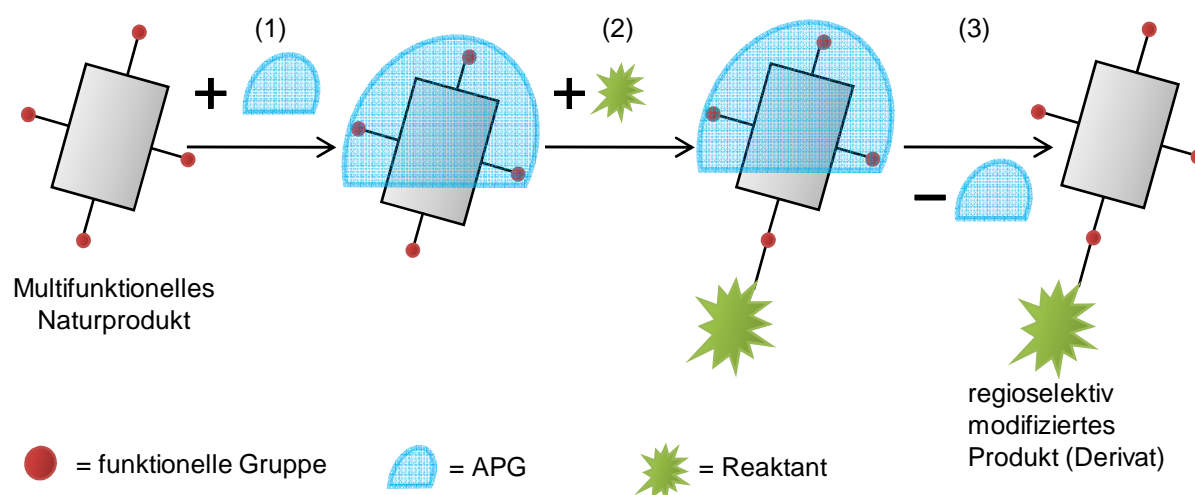

Schema 6.1: Spezifische Modifikation von multifunktionellen Naturprodukten in Gegenwart von nicht-kovalenten Aptamer-Schutzgruppen: Einführung der Schutzgruppe (1), regioselektive Transformation (2), Entfernung der Schutzgruppe (3).

Da aber RNA-Moleküle aufgrund ihrer Größe bzw. Sequenzlänge bis zu drei Bindungsstellen für ein Antibiotikum aufweisen können, kann es sein, dass ein Aminoglykosid von verschiedenen Seiten geschützt werden kann und somit verschiedene funktionelle Gruppen reagieren. Dies wiederum führt zu einem Gemisch von Regioisomeren und niedrigerer Regioselektivität trotz der Verwendung von APGs. Deswegen wurde im **dritten Kapitel** der Wirkmechanismus der RNA als nicht-kovalente Schutzgruppe aufgeklärt. Es hat sich herausgestellt, dass die verwendeten RNA-Sequenzen zwei Bindungstaschen für das Neomycin B besitzen, in denen während der Acylierung zwei unterschiedliche Derivate des Antibiotikums gebildet werden. Da aber die Bindungstaschen unterschiedliche Affinitäten für das Antibiotikum haben, konnten die Reaktionsbedingungen, speziell das RNA/Aminoglykosid-Verhältnis und die Reaktionszeit, erfolgreich optimiert werden, so dass nur eines der beiden möglichen Regioisomere favorisiert gebildet wurde. Zusätzlich haben unsere Untersuchungen in diesem Zusammenhang gezeigt, dass die Isotherme Titrationskalorimetrie sich dazu eignet, die Anwendbarkeit der RNA-Sequenzen, die mit Hilfe

von SELEX (Systematic Evolution of Ligands by EXponential Enrichment) evolviert werden können, als APGs einzuschätzen. Schließlich konnte auch gezeigt werden, dass RNA-Moleküle sogar bei höheren Temperaturen von bis zu 50 °C als Schutzgruppen eingesetzt werden können.

Um die Nutzung von APGs als eine generelle Methode in der organischen Synthese zu etablieren, konzentrierte sich die weitere Arbeit auf die Untersuchung, ob verschiedene Modifikationen an unterschiedlichen Stellen der oben genannten Antibiotika durch die APGs ermöglicht werden können. Das Ergebnis **des vierten Kapitels** zeigt deutlich, dass verschiedene chemische Reaktionen, wie Acylierung, Thiolierung und das Einführen von Azid- und Harnstoffgruppen in Gegenwart von APGs an den Aminoglykosiden durchgeführt werden können. Dabei wurden in diesem Zusammenhang ungeladene sowie positiv und negativ geladene Reaktanten für eine regioselektive Modifizierung von den Aminoglykosiden verwendet, die alle in einer hohen Regioselektivität resultierten. Schließlich wurde in diesem Kapitel gezeigt, dass in Gegenwart von gleichen RNA-Sequenzen unterschiedliche funktionelle Gruppen an den Antibiotika chemo- und regioselektiv modifiziert werden können. Auch regioselektive Mono- und Difunktionalisierung von Neomycin B konnte erfolgreich durchgeführt werden. Basierend auf den Ergebnissen aus den Kapiteln 2, 3 und 4 kann die Verwendung von nicht-kovalenten APGs als ein wertvolles neues Konzept angesehen werden, da vor allem RNA-Aptamere für eine Vielzahl an verschiedener Naturstoffklassen generiert werden können. Aufgrund dessen werden APGs basieren auf RNA ein unvermeidliches und effektives Instrument sein, um komplexe molekulare Strukturen zu derivatisieren und die Medikamentenentwicklung basieren auf Naturstoffen zu vereinfachen bzw. zu beschleunigen.

Nachdem das APG-Konzept etabliert wurde, stellt das **fünfte Kapitel** eine weitere regioselektive Modifizierungsmethode von Neomycin B vor. Auch diese Derivatisierung erfolgt in einer einzigen synthetischen Stufe aber ohne die Verwendung von kovalenten und nicht-kovalenten Schutzgruppen. Dabei befindet sich die Modifikationsstelle gerade in einem Bereich (Streptamin-Ring) des Antibiotikum, der in Bakterien im Verlauf des Resistenzmechanismus durch enzymatische Reaktionen verändert wird. Als Folge verliert das Aminoglykosid seine antibiotische Wirkung. Um diesen bakteriellen Resistenzreaktionen entgegen zu wirken, ist es in der Medikamentenentwicklung gängig, Antibiotika an jenen Stellen so zu modifizieren, dass diese im Bakterium nicht verändert werden können aber gleichzeitig die antibiotische Wirkung beibehalten. Jedoch sind diese spezifischen

Modifizierungen immer noch eine Herausforderung und darüberhinaus sehr zeitaufwendig und kostspielig. Mit dieser Motivation zeigt das fünfte Kapitel die Entwicklung einer neuen Methode, die eine Modifizierung in der C3-Position des Streptamin-Ringes in einem synthetischen Schritt ermöglicht. Unter Verwendung von einem Azid-Transfer-Reaktanten konnte eine von sechs Aminogruppen des Neamin-Antibiotikum Neomycin B regioselektiv umgesetzt werden. Die Studie dieser Reaktion hat gezeigt, dass die Regioselektivität auf der unterschiedlichen Basizität der Aminogruppen basiert. Während basische Aminogruppen aus der Reaktion ausgeschlossen werden, wird die Aminogruppe, die als einzige saure Eigenschaften aufweist, in eine Azidgruppe umgesetzt. Im weiteren Verlauf konnte gezeigt werden, dass diese Azid-Einführung für die Mehrzahl der Neamin-Antibiotika generell verwendbar ist. Somit konnten Azid-Derivate von sechs verschiedenen Antibiotika, nämlich Neomycin B, Paromomycin, Ribostamycin, Neamin, Amikacin und Apramycin, hergestellt werden.

In der Abbildung 6.1 sind alle Antibiotika dargestellt, die in einem einzigen synthetischen Schritt unter der Verwendung der oben beschriebenen Methoden modifiziert wurden. Die jeweiligen Modifikationsstellen sind mit Pfeilen angedeutet. Die in dieser Doktorarbeit vorgestellten Modifikationsmethoden vereinfachen und verkürzen deutlich den synthetischen Aufwand für die Derivatisierung von komplexen Aminoglykosiden. Vielmehr reduzieren sie die Synthese dieser Derivate der Antibiotika auf einen einzigen Schritt. Deswegen werden die Ergebnisse dieser Doktorarbeit die Entwicklung von neuen und vielversprechenden Antibiotika, die gegen resistenten Stämme eingesetzt werden können, ermöglichen.

Summary – Samenvatting – Streszczenie - Zusammenfassung



Abb. 6.1: Molekulare Strukturen von Neamin-Antibiotika. Pfeile deuten die Modifikationsstelle an, die mit Hilfe der APGs (blau) oder der Azid-Einführung selektiv umgesetzt werden konnten. Die Nummern geben die verwendete chemische Reaktion an: Acylierung (1), Thiolierung (2), Harnstoffgruppen-Einführung (3), Diazotierung (4).

Acknowledgments

dankzegging • Danksagung • podziękowanie •

In the End of my thesis I would like to acknowledge those people who supported me during my Ph.D. studies and contributed to this thesis.

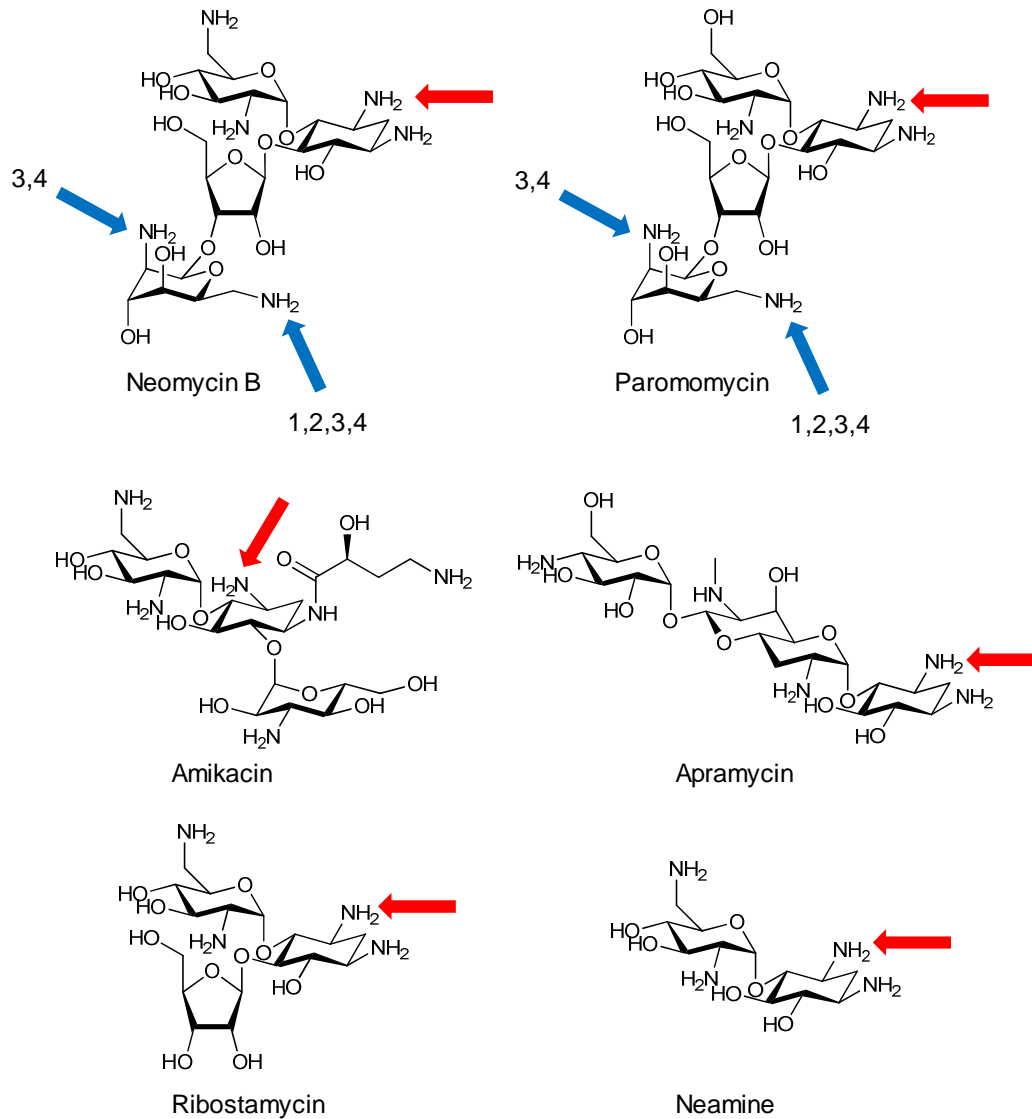
At first, I give my deepest gratitude to my supervisor Prof. Andreas Herrmann, who made my studies in the Netherlands possible. The predominantly collegial and close relationship with you facilitated the Ph.D. studies and the progress of my project. I am profoundly grateful for all your trust, encouragement and support. Especially, I like to thank you for the interdisciplinary experience I gained working with you together. It was a pleasure to join the *NGI Venture challenge*, contribute to grant applications, be part in setting up collaboration with a company and file patents. Also I like to thank you for teaching me how to write publications which facilitated the writing of my thesis. Thanks for all your advices and suggestions during my studies.

I would like to express my gratitude to the reading committee: Prof. Dr. K. Loos, Prof. Dr. G. Roelfes and Prof. Dr. H. Börner for reading and approving the manuscript in such a limited period.

In context with the participation in the *NGI Venture Challenge*, patent filing and introducing me to my prospective employer (*Syncom*) I like to thank Semme Moolenaar from *Stichting Business Generator Groningen*. Dear Semme, the business language was never one of my and

Acknowledgments

therefore, it was inspiring and motivating to have you in our team with Prof. Andreas Herrmann, Prof. Anna Hirsch and Alessio Marcozzi challenging the greatest ideas of the Netherlands during the Venture Challenge. Since working with you, I know that business is not about perfectionism but efficiency: “good is good enough”.

My thanks go also to Pieter van der Meulen from the NMR department, who helped me out with the 500 MHz NMR even during weekends to obtain nice 1D- and 2D-NMR spectra of the limited amounts of my antibiotic derivatives. Also I like to thank Theodora Tiemersma-Wegman for the frequent implementation of spectrometric measurements of my numerous samples.

Moreover, I want to express my great thanks to my colleagues Dr. Albero Rodríguez-Pulido, who performed the ITC measurements, Agnieszka Gruszka for ideas within the project and her direct contributions as well as proof reading to this thesis, Alessio Marcozzi for the measurement of the antibacterial activity, Jan Willem de Fries for translations and his support in any aspect and finally, Dr. Giuseppe Caroli for proof reading of my thesis. I like also to thank my former colleague Dr. Maciej Pudelko for very useful scientific discussion and suggestion in my entire studies.

I also would like to thank all the people that created a nice work environment during the four years in the Polymer Chemistry Department: Daniel, Tobias, Jur, Patrick, Li Fei, Kai, Alessio, Diego, Alina and Agnieszka Muszanska. Especially, my great thanks go to Pavlo and Alberto, who became great friends during my Ph. D. studies. You supported me in any manner and enabled a nice time outside the lab.

Finally, I thank my wife as well as my family and friends in Germany giving me the self-confidence and endurance during my entire studies: Als erstes danke ich dir, Maria, für deine Geduld, Kraft, Inspiration und Motivation während unseres Studiums in Deutschland und unserer Doktorarbeit in Holland, deine unermüdliche Unterstützung und grenzenlose Liebe. Ohne dich würde ich das niemals im Leben schaffen. Vor allem danke ich dir für deine Toleranz gegenüber meiner zahlreichen Launen. Ich liebe dich! Natürlich möchte ich meinem Bruder Christoph und seiner Frau Sylwia danken für eure Loyalität, Liebe und Unterstützung in jeder Lebenssituation. Ihr und eure Kinder, Dennis und Leon, haben mir verdeutlicht das Probleme relativ sind, und wie man aus jeder Lebenssituation sein Glück schöpfen kann und muss. Danke! Darüberhinaus habt ihr zusätzlich aktiv dazu beigetragen, mir meinen Ausgleich zur Arbeit in den Niederlanden zu ermöglichen. Ohne euch würde ich

Acknowledgments

ausschließlich arbeiten! Christoph, du bist mein großer Bruder, der sich immer für mich eingesetzt hat; seit meiner Geburt bis heute. Dafür danke ich dir. Chris und Peter, ihr seid die besten Freunde, die man sich wünschen kann. Ihr habt Maria und mir nicht nur die Zeit in Holland durch eure zahlreichen Besuche erleichtert, sondern habt Mainz gleichzeitig zu unserem Zuhause gemacht. „Ab auf die Piste, GEIL!!!!“

Schließlich möchte ich meinen Eltern danken, die als Ehepaar und Menschen mir ein Vorbild sind. Ich danke euch für eure Liebe, Geduld, Loyalität, Zuspruch, finanzielle und moralische Unterstützung und eure unermüdliche Hilfsbereitschaft. DANKE!