

University of Groningen

Cardiopulmonary bypass. The effect on blood elements in dogs

de Jong, J.C.F.

IMPORTANT NOTE: You are advised to consult the publisher's version (publisher's PDF) if you wish to cite from it. Please check the document version below.

Document Version

Publisher's PDF, also known as Version of record

Publication date:

1985

[Link to publication in University of Groningen/UMCG research database](#)

Citation for published version (APA):

de Jong, J. C. F. (1985). *Cardiopulmonary bypass. The effect on blood elements in dogs*. [S.n.].

Copyright

Other than for strictly personal use, it is not permitted to download or to forward/distribute the text or part of it without the consent of the author(s) and/or copyright holder(s), unless the work is under an open content license (like Creative Commons).

The publication may also be distributed here under the terms of Article 25fa of the Dutch Copyright Act, indicated by the "Taverne" license. More information can be found on the University of Groningen website: <https://www.rug.nl/library/open-access/self-archiving-pure/taverne-amendment>.

Take-down policy

If you believe that this document breaches copyright please contact us providing details, and we will remove access to the work immediately and investigate your claim.

Downloaded from the University of Groningen/UMCG research database (Pure): <http://www.rug.nl/research/portal>. For technical reasons the number of authors shown on this cover page is limited to 10 maximum.

CARDIOPULMONARY BYPASS

The effect on blood elements in dogs



J. C. F. de Jong

CARDIOPULMONARY BYPASS

The effect on blood elements in dogs

Cover illustration: "Pas de deux",
thrombocytes with pseudopodes
photo by Lennart Nilsson
© Boehringer Ingelheim BV,
Alkmaar, Netherlands

STELLINGEN

I

De toepassing van de membraan oxygenator in plaats van de bubble oxygenator in de cardiopulmonale chirurgie heeft geen zin zolang het peroperatief zuigen van bloed met lucht niet wordt voorkomen.

dit proefschrift

II

Het slangencircuit en de bloedpompen van een hart-longmachine beschadigen het bloed in mindere mate dan de oxygenator en de suctie-apparatuur.

dit proefschrift

III

Bij het gebruik van de hart-longmachine is de peroperatief gemeten afwijking in aantal en functie van de bloedcellen niet bepalend voor de beschadiging die in de postoperatieve periode tot uiting komt.

dit proefschrift

IV

De praktische mogelijkheden voor de opwerking van een plasma-pool in eiwitconcentraten worden niet bepaald door de schaal van het opwerkingsproces, maar door de opwerkingsmethode.

V

De verspreiding van AIDS (Acquired Immune Deficiency Syndrome) wordt in belangrijke mate bepaald door de ethische en morele grenzen, die het individu en de gemeenschap weten te stellen aan intiem intermenselijk verkeer.

VI

Van oudere patienten, die langdurig met diuretica worden behandeld, dient ten minste jaarlijks de kaliumconcentratie van het serum te worden bepaald.

Judge TG, Caird FI: Drug treatment of the elderly patient.
Pitman Med Publ Comp, Tunbridge Wells, 1978, 94

VII

Het is gewenst dat chemisch en biofarmaceutisch kwaliteitsonderzoek van in de openbare apotheek op voorraad bereide geneesmiddelen in regionale laboratoria mogelijk wordt gemaakt.

Rapportage Werkgroep Profiel Openbare Apotheker KNMP 1985
Bult A: Pharm Weekbl 117: 237, 1982

VIII

Een statistisch significant verschil in een vergelijkend klinisch geneesmiddelenonderzoek zegt soms meer over de kwaliteit van de statisticus dan over de kwaliteit van het geneesmiddel.

Core SM: Br Med J 283: 600, 1981

IX

Het verstrekken van grotere hoeveelheden geneesmiddelen als gevolg van de invoering van de zg. eigen bijdrage lijkt met name onder bejaarden zelfdoding bereikbaarder, zij het nog steeds onzeker, te maken.

X

Vergroting van de ADL-zorg (Activiteiten van het Dagelijks Leven) voor bewoners van verzorgingshuizen is gewenst om voortijdige overplaatsing naar verpleeghuizen te voorkomen.

XI

De kennelijke opleving van "kleine" talen zoals het Saksisch, het Wels, het Baskisch en het Fries is te beschouwen als de regionale reactie op een als bedreigend ervaren, grootschalige en wereldwijde informatieverspreiding, die met name via de televisie tot stand komt.

XII

Voor de communicatie in de wetenschap is het visualiserend vermogen van de beeldende kunstenaar onontbeerlijk.

XIII

Bloed kruipt waar het niet gaan kan.

Stellingen
behorende bij het proefschrift van
J.C.F. de Jong
Cardiopulmonary Bypass -
the Effect on Blood Elements in Dogs
Groningen, 1985

Rijksuniversiteit te Groningen

CARDIOPULMONARY BYPASS
The effect on blood elements in dogs

PROEFSCHRIFT

ter verkrijging van het doctoraat in de Geneeskunde
aan de Rijksuniversiteit te Groningen
op gezag van de Rector Magnificus Dr E. Bleumink
in het openbaar te verdedigen op woensdag 5 juni 1985
des namiddags te 2.45 uur precies
door
JEROEN CORNELIS FRANS DE JONG
geboren te Rotterdam

1985
Speciaaldrukkerij Europrint BV
Veendam

Eerste promotor: Prof. Dr Ch.R.H. Wildevuur
Tweede promotor: Prof. Dr M.R. Halie
Referent : Dr C.Th. Smit Sibinga

Het in dit proefschrift beschreven onderzoek is mede mogelijk gemaakt door financiële steun van de Nederlandse Hart Stichting (74.013)

Recite in the name of your Lord who created,
created man from clots of blood!
Recite! Your Lord is the Most Beautiful One,
who by the pen taught man what he did not know.
Indeed, man transgresses in thinking himself his own
master: for to your Lord all things return.

The Koran 96:1,
translations N.J.Dawood,
Penguin Books (1983)

Dedicated to Gerda and
our children Marieke, Gijsbert, Michiel and Annelies

-
In memory of my father Frits Jacob de Jong

ACKNOWLEDGEMENTS

The research project described in this thesis was performed at the division of Experimental Surgery (Head: Prof. Dr Ch.R.H. Wildevuur) of the Department of Surgery (Head: Prof. Dr P.J. Kuijjer) of the University Hospital Groningen, Netherlands.

The experiments were carried out in co-operation with the Coagulation Laboratory (at that time Head: Dr C.Th. Smit Sibinga) of the Division of Hematology (Head: Prof. Dr H.O. Nieweg) of the Department of Medicine (Head: Prof. Dr E. Mandema) of the University Hospital Groningen.

I would like to express my sincere appreciation to Prof. Dr Ch.R.H. Wildevuur, Prof. Dr H.R. Halie (presently Head of the Division of Hematology) and Dr C.Th. Smit Sibinga (presently Director of the Red Cross Blood Bank Groningen-Drenthe) for their invaluable help, stimulation and constructive criticism during the experiments and during the preparation of this manuscript.

My special thanks are due to Dr H.J. ten Duis, who gave valuable practical assistance with the experimental work and with whom many problems were continuously discussed. Dr J. van den Dungen and Drs W. van Oeveren provided useful critical comments.

J.M. Elstrodt (Head), K.J. Bel, D. Meijer, P.A. Klok, N. Westerhof, Mrs A. Lanjouw-de Jong, Mrs B. Stienstra-Hansen, P. Jorna, R. Paping, Miss R. Stienstra, and H. van der Schoot gave excellent technical, operative and laboratory assistance for the experiments performed at the Central Animal Laboratory. The dogs were well cared for by A. Heikamp.

Technical and statistical help were provided by Ir P.H. Mook and Drs J. Burema.

Gerda, my wife, skilfully and patiently checked several versions of the manuscript for linguistic mistakes, together with The Very Rev. J.R. Arnold.

Mrs M. Munstra-Zuidema, Mrs E. Pinkster and Miss I. Wildevuur carefully typed many editions of the manuscript. J.J.P. Bruyns mastered the word processor with which the last editions and the final manuscript were prepared.

This project was partly supported by the Dutch Heart Foundation (grant 74.013).

Last but not least Gerda, our children and my parents deserve a special place in these acknowledgements: my parents for providing my education and the possibility of studying at this University, our children for helping me to remember that there are more important things in this world than a thesis, and especially Gerda for her loving, persistent and critical support of this prolonged project.

Table of contents	1
Abbreviations	5
<u>CHAPTER 1 - PROLOGUE</u>	7
<u>1.1. Introduction</u>	7
<u>1.2. Complications of cardiopulmonary bypass</u>	8
1.2.1. Anemia	
1.2.2. Bleeding	
1.2.3. Infection and organ dysfunction	
<u>1.3. Interaction between blood and biomaterial</u>	11
<u>1.4. Species dependence</u>	12
<u>1.5. Purpose of the investigation</u>	13
<u>CHAPTER 2: MATERIALS AND METHODS</u>	15
<u>2.1. Introduction</u>	15
<u>2.2. Animal model</u>	15
2.2.1. Dogs	
2.2.2. Anesthesia	
2.2.3. Anticoagulation	
2.2.4. Priming procedure	
2.2.5. Operation technique	
<u>2.3. Variables of the extracorporeal circuit</u>	19
2.3.1. Tubing	
2.3.1.1. PVC tubing	
2.3.1.2. Silicone rubber (SR) tubing	
2.3.1.3. Silica free silicone rubber (SFSR) tubing	
2.3.2. Blood pump	
2.3.2.1. Roller pump	
2.3.2.2. Rotor pump	
2.3.2.3. Centrifugal pump	
2.3.3. Oxygenator	
2.3.3.1. Bubble oxygenator (BO)	
2.3.3.2. Teflo membrane oxygenator (TMO)	
2.3.3.3. Kolobow membrane oxygenator (Kolobow MO)	
2.3.4. Cardiotomy suction	
2.3.4.1. High vacuum suction	
2.3.4.2. Controlled suction	
<u>2.4. Experimental series</u>	23
<u>2.5. Experimental setup</u>	25
<u>2.6. Experimental protocol</u>	29
<u>2.7. Laboratory methods</u>	32
2.7.1. Number of thrombocytes, leukocytes and erythrocytes	
2.7.1.1. Technique	

2.7.1.2.	Correlation between microscopic counting and electronic particle counting	
2.7.2.	Function of thrombocytes	
2.7.2.1.	Technique	
2.7.2.2.	Correction by means of nomogram	
2.7.3.	Bleeding time	
2.7.4.	Hematocrit, hemoglobin and plasma hemoglobin	
2.7.5.	Fibrin formation	
2.7.6.	Sedimentation rate of the erythrocytes (SRE)	
2.7.7.	Body temperature	
2.7.8.	Normal hematological values in dogs	
<u>2.8.</u>	<u>Statistical analysis</u>	36
 <u>CHAPTER 3: INFLUENCE OF THE CIRCUIT MATERIAL</u>		39
<u>3.1.</u>	<u>Preface</u>	39
<u>3.2.</u>	<u>Series I: polyvinylchloride (PVC) tubing</u>	39
3.2.1.	Introduction	
3.2.2.	Number of thrombocytes	
3.2.3.	Function of thrombocytes: ODmax	
3.2.4.	Bleeding time	
3.2.5.	Hemoglobin, hematocrit, number of erythrocytes, plasma hemoglobin	
3.2.6.	Number of leukocytes	
3.2.7.	SRE, body temperature	
3.2.8.	Fibrinogen	
3.2.9.	Activated partial thromboplastin time (APTT), prothrombin time (PTT), reptilase time (RT), and thrombin time (TT)	
<u>3.3.</u>	<u>Series IV: silica free silicone rubber tubing (SFSR) vs series I: PVC tubing</u>	48
3.3.1.	Introduction	
3.3.2.	Number of thrombocytes	
3.3.3.	Function of thrombocytes: ODmax	
3.3.4.	Bleeding time	
3.3.5.	Hematocrit, number of erythrocytes, plasma hemoglobin	
3.3.6.	Number of leukocytes	
<u>3.4.</u>	<u>Series III: silica filled silicone rubber tubing (SR) vs series II: SFSR tubing</u>	55
3.4.1.	Introduction	
3.4.2.	Number of thrombocytes	
3.4.3.	Function of thrombocytes: ODmax	
3.4.4.	Bleeding time	
3.4.5.	Hematocrit, number of erythrocytes, plasma hemoglobin	
3.4.6.	Number of leukocytes	

<u>3.5. Discussion</u>	62
3.5.1. General reaction	
3.5.1.1. Number of thrombocytes	
3.5.1.2. Function of thrombocytes: ODmax	
3.5.1.3. Bleeding time	
3.5.1.4. Hematocrit, number of erythrocytes, plasma hemo- globin	
3.5.1.5. Number of leukocytes	
3.5.1.6. SRE	
3.5.1.7. Body temperature	
3.5.1.8. Fibrinogen, APTT, PTT, RT, and TT	
3.5.2. Comparative analysis	
<u>3.6. Conclusions</u>	80
<u>CHAPTER 4: INFLUENCE OF THE BLOOD PUMP</u>	83
<u>4.1. Preface</u>	83
<u>4.2. Series IV: roller pump vs series II: rotor pump</u>	83
4.2.1. Introduction	
4.2.2. Number of thrombocytes	
4.2.3. Function of thrombocytes: ODmax	
4.2.4. Bleeding time	
4.2.5. Hematocrit, number of erythrocytes, plasma hemoglobin	
4.2.6. Number of leukocytes	
<u>4.3. Series V: centrifugal pump vs series II: rotor pump</u>	90
4.3.1. Introduction	
4.3.2. Number of thrombocytes	
4.3.3. Function of thrombocytes: ODmax	
4.3.4. Bleeding time	
4.3.5. Hematocrit, number of erythrocytes, plasma hemoglobin	
4.3.6. Number of leukocytes	
<u>4.4. Discussion</u>	97
<u>4.5. Conclusions</u>	99
<u>CHAPTER 5: INFLUENCE OF THE OXYGENATOR</u>	101
<u>5.1. Preface</u>	101
<u>5.2. Series VI: BO vs series VII: TMO</u>	101
5.2.1. Introduction	
5.2.2. Number of thrombocytes	
5.2.3. Function of thrombocytes: ODmax	
5.2.4. Bleeding time	

5.2.5. Hematocrit, number of erythrocytes, plasma hemoglobin	
5.2.6. Number of leukocytes	
<u>5.3. Series VIII: TMO in optimal circuit vs series VII: TMO</u>	108
5.3.1. Introduction	
5.3.2. Number of thrombocytes	
5.3.3. Function of thrombocytes: ODmax	
5.3.4. Bleeding time	
5.3.5. Hematocrit, number of erythrocytes, plasma hemoglobin	
5.3.6. Number of leukocytes	
<u>5.4. Series IX: Kolobow MO vs series VIII: TMO in optimal circuit</u>	115
5.4.1. Introduction	
5.4.2. Number of thrombocytes	
5.4.3. Function of thrombocytes: ODmax	
5.4.4. Bleeding time	
5.4.5. Hematocrit, number of erythrocytes, plasma hemoglobin	
5.4.6. Number of leukocytes	
<u>5.5. Discussion</u>	121
<u>5.6. Conclusions</u>	129
<u>CHAPTER 6: INFLUENCE OF THE CARDIOTOMY SUCTION</u>	131
<u>6.1. Preface</u>	131
<u>6.2. Series XI: TMO + high vacuum suction vs series VII: TMO and series VI: BO</u>	131
6.2.1. Introduction	
6.2.2. Number of thrombocytes	
6.2.3. Function of thrombocytes: ODmax	
6.2.4. Bleeding time	
6.2.5. Hematocrit, number of erythrocytes	
6.2.6. Number of leukocytes	
<u>6.3. Series X: TMO + controlled suction vs se- ries VII: TMO and series VI: BO</u>	137
6.3.1. Introduction	
6.3.2. Number of thrombocytes	
6.3.3. Function of thrombocytes: ODmax	
6.3.4. Bleeding time	
6.3.5. Hematocrit, number of erythrocytes, plasma hemoglobin	
6.3.6. Number of leukocytes	
<u>6.4. Discussion</u>	144
<u>6.5. Conclusions</u>	147
Summary	149
Samenvatting	155
References	161

ABBREVIATIONS

ACT	-	activated clotting time
ADP	-	adenosine diphosphate
APTT	-	activated partial thromboplastin time
BO	-	bubble oxygenator
BW	-	body weight
CPB	-	cardiopulmonary bypass
DIC	-	disseminated intravascular coagulation
ECC	-	extracorporeal circulation
emf	-	electromagnetic flowprobe
g	-	gram
h	-	hour
Hb	-	hemoglobin
Hct	-	hematocrit
IU	-	international unit
kg(s)	-	kilogram(s)
l	-	liter
m	-	meter
M	-	molar
mg	-	milligram
μ g	-	microgram
min(s)	-	minute(s)
mm	-	millimeter
mmol	-	millimolar
μ mol	-	micromolar
MO	-	membrane oxygenator
MPV	-	mean platelet volume
ODmax	-	maximal optical density loss
opt.circ.	-	optimal circuit
PF	-	platelet factor
PG	-	prostaglandin
p.o.	-	postoperative(ly)
PT	-	prothrombin time
PVC	-	polyvinylchloride
ppp	-	platelet poor plasma
prp	-	platelet rich plasma
RES	-	reticulo endothelial system
rpm	-	rounds per minute
RT	-	reptilase time
sd	-	standard deviation
sec(s)	-	second(s)
sem	-	standard error of the mean
SFSR	-	silica free silicone rubber
SR	-	silicone rubber
SRE	-	sedimentation rate of the erythrocytes
stand.circ.	-	standard circuit
TMO	-	Teflo membrane oxygenator
TT	-	thrombin time
vs	-	versus

CHAPTER 1: INTRODUCTION

1.1. INTRODUCTION

Only since World War II have artificial organs been capable to take over the functions of vital organs, such as kidneys, lungs and heart. With a failing renal function artificial kidneys have been widely used to purify the blood intermittently, but problems initiated by complement activation have not yet been solved. During cardiac surgery the artificial lung has been routinely employed for a short period, but hemolysis and platelet damage are still inevitable consequences of cardiopulmonary bypass (CPB). Around 1960 these consequences were already established by Dorlas (1960) and Homan van der Heide (1960) from Groningen, who investigated the applicability of a bubble oxygenator (type Lillehei-DeWall) for oxygenation during open-heart surgery procedures. Their successful experiments on dogs were followed by employment of this cirrestor in patients. For long term replacement of the respiratory function the effective gas exchange of the artificial lung is limited to days or a few weeks, but many complications related to blood damage are encountered like impaired hemostasis and infections. Several types of artificial hearts have been implanted in laboratory animals. Kolff and his co-workers in Salt Lake City, for instance, have succeeded in keeping calfs with implanted hearts alive for periods of up to 268 days (Hastings et al., 1981), but continuous activation of the intrinsic clotting cascade has required permanent anticoagulation. Recently deVries and Jarvik successfully implanted an artificial heart in a human being. However, this first patient died of infection after 112 days (Joyce et al., 1983). From this brief survey it may be clear that, although the function of several vital organs can be taken over effectively for shorter or longer periods, the problems of blood trauma due to activation by the nonphysiological materials have not yet been overcome.

Nowadays CPB is a relatively safe procedure despite the fact that the complete circulation and ventilation of the patient have to be taken over. In the CPB procedure the regulation of hemodynamics and gas exchange is well under control. However, relatively little is known about the activation of enzyme systems and the blood cells. Morbidity and mortality after cardiac operations are mainly associated with

the secondary effects of the activation of enzyme systems and damage to the blood elements (Lee et al., 1971).

Next to surgical techniques, progress in cardiac surgery depends to a large extent on improvements accomplished in CPB. Right from the beginning of open heart surgery in the early 1950s severe damage to the blood has been recognized as one of the inevitable consequences of CPB. Even today, after almost 30 years of extensive experience and research which have provided substantial improvements in the CPB components, we still have a poor understanding of the blood damage: its principal causes, its effects on the patient and, last but not least, its prevention. For example, the intrinsic clotting cascade is activated by CPB to such an extent that immediate coagulation will occur in the circuit. Only the discovery of heparin has made extracorporeal circulation in general and CPB in particular possible. However, other cascades like those of kallikrein, fibrinolysis and complement system are also activated, but the investigation into the consequences of all these activations has only just begun.

Apart from the activation by blood contacting materials, other factors also determine the hemocompatibility of the CPB system like concentration and reactivity of the blood elements, flow conditions including mechanical trauma and shear stress, temperature, anticoagulants, and priming solutions. Each factor has an effect on blood damage but not to the same extent and not with a preference for the same blood elements.

To elucidate the relations between blood damage and CPB detailed investigations are needed to learn the contributions of the different parts of the extracorporeal circuit. Once the contribution of each link of the extracorporeal chain is known, improvements with regard to hemocompatibility can be obtained. Tubing materials can be changed, blood pumps replaced, and oxygenators and cardiotomy suction system improved. Only improvement of each link can ultimately preserve optimal hemocompatibility of the whole CPB chain.

1.2. COMPLICATIONS OF CARDIOPULMONARY BYPASS

Complications as a results of the hematological alterations caused by CPB are: anemia, bleeding, infection, and organ dysfunction. These complications still contribute to the mortality and morbidity after cardiac surgery today.

1.2.1. Anemia

In the early days of CPB hemolysis was a prominent

manifestation of massive damage to the erythrocytes. In those days hemocompatibility was measured and described in terms of hemolysis and the estimation of plasma hemoglobin was used as the quantitative indication. However, hemolysis as an expression of direct erythrocyte damage only tells a part of the story of red cell damage. Moreover, it only yields limited information, since plasma hemoglobin levels are not only related to damage to the erythrocytes but also to the processes of binding to plasma proteins and elimination.

Technical improvements of the heart-lung machine have greatly limited direct mechanical destruction of erythrocyte membranes and therefore hemolysis. However, mechanical forces can also affect membrane fragility resulting in subhemolytic damage of the erythrocytes, which reduces the survival time (O'Rear et al., 1979). Sublethal erythrocyte damage does not necessarily raise the plasma hemoglobin concentration, but can be responsible for postperfusion anemia (Birnbaum et al., 1977). Bernstein et al. (1967) concluded from their work that sublethal erythrocyte damage is more important than direct hemolysis; they calculated that simultaneously with the lysis of one erythrocyte hundreds of red cells are sublethally altered. Bernstein also stated that the magnitude of hemolysis in the first 24 hours after perfusion may be as much as four times greater than the immediate hemolysis. This postperfusion anemia may last for a period of one week (Galletti, 1965). Although severe hemolysis during CPB has become rare, postoperative anemia still is a common consequence of cardiac surgery. Because no studies are available to relate the extent of postoperative anemia to the various components of the extracorporeal circuit, it is one of the aims of this thesis to establish this relationship.

1.2.2. Bleeding

Severe bleeding after CPB procedures, occurring in about four percent of all cardiac operations (Gomes et al., 1980), is related to major decreases in the coagulation factors and in number and function of circulating thrombocytes. Most reports about bleeding tendencies after CPB disclose loss of thrombocytes as the main cause. Markedly prolonged bleeding times occur even more frequently when the coagulation factors have also been affected.

Several authors have reported postoperative disturbances in the coagulation mechanism, especially in factor V, which may result in excessive bleeding (Bachmann et al., 1975; Moriau et al., 1977; Kalter et al., 1979). Kalter also suggested a minor role for

disseminated intravascular coagulation or increased fibrinolysis. All these investigations have demonstrated that, despite systemic heparinization, activation and consumption of clotting factors do occur during CPB. However, the primary cause of this activation of the clotting cascade is not exactly known.

Although the coagulation mechanism may be disturbed after CPB, it only plays a minor role in the problem of postoperative bleeding and only adds to otherwise generated hemostatic problems (Bick et al., 1976; Heiden et al., 1977). The major causes are found in decreases in number and function of the thrombocytes. The generally accepted normal pattern of thrombocyte loss is as follows (Salzman, 1963; McKenzie et al., 1969; de Leval et al., 1972; McKenna et al., 1975; Kalter et al., 1977): during CPB the number of circulating thrombocytes drops to less than half of the initial amount. Shortly after CPB some increase is noticed but the number remains low for a period of two or three days. Thereafter the number increases until the preoperative value is reached after about one week. In some cases thrombocythemia is found for a period of five days thereafter, but after three weeks the number reaches the preoperative level again.

The course of thrombocyte function has been less extensively studied than the pattern of thrombocyte number, and only a limited amount of information is available (de Leval et al., 1972; McKenna et al., 1975; Kalter et al., 1977). Thrombocyte adhesiveness is sharply reduced after the start of CPB, remains low during perfusion and then gradually returns to the normal range. Thrombocyte aggregation induced with ADP, adrenaline or collagen decreases during CPB, increases again from the third day and reaches preoperative levels after one week.

Few studies have explored the contributions of the various components of CPB to platelet damage. So an optimal circuit with respect to thrombocyte preservation during CPB has not yet been described. Such an attempt will be made in this thesis.

1.2.3. Infection and organ dysfunction

Infection and lung dysfunction are related to activation of and damage to complement factors and leukocytes. Complement activation by biomaterials induces leukocyte aggregation. These aggregates plug capillaries in the lung and cause the so-called post perfusion syndrome by the release of proteolytic enzymes and oxygen radicals (Hammerschmidt et al., 1979). Moreover, interaction between biomaterials and leukocytes may result in changes in number and

function of circulating leukocytes. Impairment of chemotaxis (Skubitz et al., 1981) and phagocytosis (Silva et al., 1974) will affect the defense mechanism against infection. In combination with the risk of airborne contamination during CPB (Blakemore et al., 1971; Dankert et al., 1978), a substantial incidence of infection can be expected and has indeed been reported (Goodman et al., 1968), including sepsis. Studies of complement activation during CPB are still limited in number, because no well standardized methods of quantitating complement activation were available in the past. Recently radioimmunoassays for C3a and C4a have been developed for human beings. However, such assays are not yet available for animal studies. So a systematic study of the contribution of each CPB component in relation to infection in well standardized canine experiments is not feasible at the present time.

1.3. INTERACTION BETWEEN BLOOD AND BIOMATERIAL

In the 1950s and 1960s a great deal of effort has been spent on investigating the interaction of blood and biomaterials. Most studies dealing with the problem of assessing hemocompatibility focus upon the effect on the clotting cascade, but clearly this cannot be regarded as the sole index. Considering the whole interrelationship between device and living organism, multiple systems beyond the coagulation process are involved like complement activation, the relationship between complement activation and the coagulation process, surface microrheological phenomena, protein dynamics, and electrochemical phenomena at the blood-biomaterial interface. Moreover, interlaboratory comparison and correlation of the test procedures and research data should be facilitated by using reference materials and methodologies that have become available.

Several ways are open for improving hemocompatibility. One of them is to look for better hemocompatible biomaterials like polyurethanes which selectively adsorb albumin, thus preventing thrombocyte adhesion (Lyman et al., 1975), or to develop new materials which do not activate any of the systems mentioned. Another approach is to coat biomaterials with drugs. Biomaterials have been coated with heparin, covalently bound (Leininger et al., 1972; Lagergren et al., 1974) or leaking from the coating in a controlled way (Tanzawa et al., 1973), or attached by the formation of a complex of a quaternary salt (Toomasian et al., 1983). Coating with prostaglandins (McRea et al., 1978) to prevent platelet adhesion has also been studied. However, none of these systems is available for practical use

at present.

Extracorporeal circulation can also be combined with the simultaneous administration of drugs to prevent the activation of the various cascades. Heparin is commonly used to prevent clotting. Inhibition of thrombocyte reactions like adhesion, aggregation and release has also been attempted with drugs like PGE₁, PGI₂, dipyridamole and sulfinpyrazone (van den Dungen, 1983). According to Mielke et al. (1973) "the ideal drug would effectively alter the platelet surface reaction without causing impairment of the platelet function". However, so far such an ideal drug has not been found.

At this moment the most practical approach to improving the hemocompatibility of the CPB circuit is to evaluate systematically the contribution of the many components from which such a CPB circuit is composed to blood damage. Broadly the components of the CPB are: tubing materials, blood pump, oxygenator and suction device. After such an evaluation a optimally hemocompatible extracorporeal circuit can be assembled by combining the optimally hemocompatible components. This concept of systematic evaluation and optimization to be performed in animal experiments under strictly standardized conditions forms the basis of the present dissertation and seems likely to improve CPB in the clinical situation.

1.4. SPECIES DEPENDENCE

Dogs were chosen to be used as experimental animals. This choice, however, raises questions: can the results of the experiments on dogs in mimicked clinical circumstances be transposed to the procedures on human beings in the operating theater? For instance, species related differences between human beings and dogs exist with respect to the interaction of blood and biomaterials. Canine thrombocytes are generally much more reactive to biomaterials than human thrombocytes. In this respect the dog is probably a good species. However, the group of Grabowski has also shown that the surface reaction is dependent on the kind of polymer used, so that canine thrombocytes under certain circumstances may even be less reactive than human thrombocytes (Grabowski et al., 1977; Lewis et al., 1979).

In a strict sense it is only allowed to compare results within one species and it is dangerous to make quantitative predictions concerning blood trauma in human beings. Nevertheless it has been assumed that the dog's tolerance of a certain artificial device in terms of erythrocytes, thrombocytes and coagulation implicates that the device will probably also be tolerated by man. Consequently, the dog has

been widely used as an experimental animal to study the effect of extracorporeal circulation (Schmid-Schönbein, discussion, 1979; Newland, 1977), despite the absence of direct applicability of the conclusions from such experiments on dogs to the clinical situation. Moreover comparison of the conclusions from canine CPB experiments in our laboratory with those from later similar investigations in human beings during open heart surgery has shown that, under these circumstances, the dog provided a very suitable animal model to perform basic research (van den Dungen et al., 1982).

1.5. PURPOSE OF THE INVESTIGATION

The manifold unanswered questions concerning the hematological response towards cardiopulmonary bypass have prompted us to perform a systematic hematological investigation in strictly standardized animal experiments. The purposes of this investigation are:

1. to determine the hematological alterations induced by the various components from which a CPB circuit is composed (circuit materials, blood pumps, oxygenator, and cardiotomy suction device) in concentrations and functions of blood cells and in fibrin formation.
2. to compose a optimally hemocompatible CPB for cardiac surgery by joining the least traumatic components and to prove its superiority.

The outline of the thesis is as follows:

Chapter 1 gives the introduction to the subject.

Chapter 2 provides a description of the materials and methods used in this investigation.

Chapter 3 describes the general behaviour of blood components when exposed to the basic elements of an extracorporeal circuit (ECC), tubing and pumps, and compares three different tubing materials.

Chapter 4 describes the hematological alterations caused by three different blood pumps. The results of chapters 3 and 4 together indicate the basic elements for an optimal extracorporeal circuit.

Chapter 5 describes the hematological alterations caused by different oxygenators (one bubble oxygenator and two membrane oxygenators) with the standard elements of an ECC and with the optimal circuit. The results of chapters 3, 4 and 5 together indicate a optimally hemocompatible heart-lung machine.

Chapter 6 describes the hematological alterations caused by two different methods of cardiomy suction: suction of blood with and without air from the thoracic cavity. The results of chapters 3, 4, 5, and 6 together indicate the optimal equipment for CPB procedures.

In this systematic evaluation it is possible to assess hematological alterations caused by each single component of the CPB circuit and to choose the components for the optimally hemocompatible CPB equipment. Finally this knowledge can be transferred from the experimental animal laboratory to the human clinical situation.

CHAPTER 2: MATERIALS AND METHODS

2.1. INTRODUCTION

This chapter provides a description of the materials and methods used in this experimental investigation. If possible the testing procedures, materials and laboratory methods were selected that are used in the clinical situation. Only a few methods needed adaptation to dissimilar canine properties (e.g. blood cell counts). Apart from the assessment of the hematological parameters, which will be described in detail, the electrocardiogram, the systemic arterial blood pressure (SAP) and the central venous blood pressure (CVD) were recorded continuously to control physiological conditions. Arterial blood gas values (pO_2 , pCO_2 , SaO_2) and pH were measured at regular intervals to assure correct operation of the oxygenator and adequate blood flows to the tissues.

2.2. ANIMAL MODEL

2.2.1. Dogs

In all experiments mongrel dogs of either sex weighing between 27 and 35 kgs were used. The average weight was 30 kgs. Every dog was experimented upon only once. One week prior to the experiment the physically healthy dog underwent a hematological examination. Exclusion from the experiments followed if cellular blood counts, bleeding time, thrombocyte function or sedimentation rate of the erythrocytes (SRE) were not within the normal range of our laboratory (see 2.7.8.). From one week before the experiment the animals were fed on Canex[®] dry food (Hope Farms, Woerden, Netherlands). The day before the experiment food was withheld, but water intake was allowed without restriction.

2.2.2. Anesthesia

Premedication included intramuscular administration of 0.5 mg atropine sulphate and 50 mg pethidine hydrochloride. After 15 minutes a Braunule (no GI, B.Braun, Belsungen, BRD) was inserted into the cephalic vein and anesthesia was induced with sodium pentothobarbital 30 mg/kg intravenously. After intubation (Rüsch endotracheal tube nr 36-44) anesthesia was continued as soon as possible with fluo-

thane (Halothan[®], ICI, Rotterdam, Netherlands) 0.5 % in a gas mixture of N₂O 4 l/min and O₂ 2 l/min. The animals breathed spontaneously in an open system according to Waters (Med. Ind. Eq. Ltd., London, UK). The temperature of the dogs was kept constant by using heating mattresses (Gayman, USA) and a Thermo circulator (type LTCK, Churchill Ltd., Greenford, Middlesex, UK).

During thoracotomy and suction the dogs were artificially ventilated (Monaghan M 300, Denver, Colorado, USA). Every hour 25 mg pethidine hydrochloride was administered intramuscularly. Muscle relaxation was effected with intravenous injection of 5 mg succinylcholine hydrochloride and this amount was repeated every 20 minutes. The last dose was given 20 minutes before closing the thorax in order to allow quick spontaneous breathing after termination of the ECC period.

2.2.3. Anticoagulation

Anticoagulation of the animals was achieved by means of systemic heparinization. The Celite Activated Clotting Time (ACT) and a Hemochron clottimer (model 400, Int. Technidyne Corp., Edison, NJ, USA) were used to measure heparin levels (Bull et al., 1975). Baseline values were established before anticoagulation was instituted by intravenous administration of an initial dose of 100 IU of bovine lung heparin per kg bodyweight. After 5 mins the ACT was measured and the same dose of heparin was repeated, followed by reassessment of the ACT. In accordance with Bull and Akl et al. (1980) the resulting dose-response curve (figure 2.2.3.) was a straight line through these three points. If needed this curve was extrapolated in order to calculate and to administer the required additional dose of heparin to prolong the ACT to 480 secs. During the operation and ECC, hourly measurements of the ACT were performed in order to maintain the effect of the heparin concentration around the desired level of 480 secs. After disconnection of the circuit the ACT was measured and the remaining amount of heparin in the circulation was calculated from the dose-response curve. Heparin was then neutralized by slow intravenous injection of protamine hydrochloride (Protamine[®], Vitrum, Stockholm, Sweden) in an amount of 1.3 mg protamine hydrochloride for each 100 IU heparin. Subsequently, the ACT was measured after 5 and 15 mins to ensure complete neutralization of heparin.

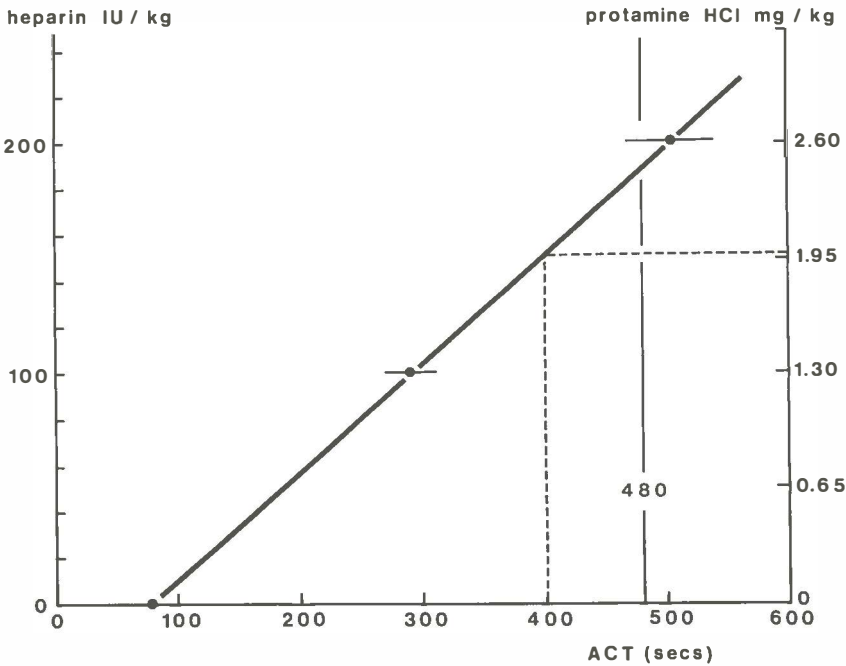

Figure 2.2.3. ACT dose-response curve

This curve was constructed from ACT values (mean value \pm sd; n=10) obtained by repeated injection of 3000 IU heparin to dog H 2473 weighing 30 kgs. The 480 secs line represents the optimal heparin level. The required amount of protamine hydrochloride (2.0 mg/kg bodyweight) was calculated from the ACT (400 secs) at the end of ECC.

2.2.4. Priming

The extracorporeal circuits were primed with fluid mixtures consisting of equal volumes of homologous canine CPD donor blood (kept for maximally one day at 4°C; prior to priming the blood was heparinized (5000 IU/l) and 1 g/l calcium levulinate was added to neutralize the citrate anticoagulant) and gelatin plasma expander (Haemaccel[®], Behring, Mannheim, BRD). Only for series II unmixed donor blood was used. The volumes required to prime the various components of the extracorporeal circuits are listed below:

ECC component	priming volume	
PVC tubing sytem, including heat exchanger	2	l
Silica free silicone rubber (SFSR) tubing syst.	1	l
Silicone rubber (SR) tubing system	1	l
Centrifugal pump	0.1	l
Temptrol bubble oxygenator Q110 (BO)	1	l
Teflo membrane oxygenator (TMO)	0.4	l
Kolobow MO	0.4	l
Suction system	0	l

According to this scheme the following amounts of priming fluid were used in the 11 consecutive series of experiments:

experiment	priming volume		ratio blood: plasma expander
series I	2	l	1 : 1
series II	1	l	1
series III	1	l	1 : 1
series IV	1	l	1 : 1
series V	1.1	l	1 : 1
series VI	3	l	1 : 1
series VII	2.4	l	1 : 1
series VIII	1.4	l	1 : 1
series IX	1.4	l	1 : 1
series X	2.4	l	2 : 1
series XI	2.4	l	1 : 1

Circuits were primed under aseptic conditions according to standard procedures. The fluids were allowed to circulate for 15 mins before connection of the circuit to the dog in order to remove any remaining air and to reach a constant temperature. When an oxygenator was interconnected in the circuit, a 2 l/min gas mixture of air with 5 % CO₂ was added.

According to the manufacturer's instructions the Kolobow MO was primed after flushing with pure CO₂ to replace all the air (Kolobow et al., 1977; 1978).²

Immediately after the termination of ECC so much blood present in the extracorporeal circuit was returned to the animal to compensate for blood loss during the experiment (samples, hemodilution, bleeding time measurements, blood loss during surgery).

During the day of the experiment (0-240 mins) the stated results of cellular counts, hemoglobin, plasma hemoglobin, and fibrinogen are independent of hemodilution because of correction for changes in the hematocrit.

2.2.5. Operation technique

After anesthesia had been induced, the dog was placed on the operating table in a dorsal position. ECG needle electrodes were placed subcutaneously in the lead II position. The urine bladder was cannulated with a Sterimed type CH 10 (Saarbrücken, BRD) catheter and connected with a urometer (Curity Kendall Hospital Prod. Div., USA). An Ellab (Kopenhagen, Denmark) thermometer was placed rectally. The left femoral artery and vein were prepared. The artery was cannulated with an E-Z catheter (EZ no. 2234 Deseret Pharm. Company, USA) and connected with a pressure transducer (Statham, P 23 Db, Hato Rey, USA); the systemic arterial pressure (SAP) was registered on a chart recorder (Hewlett-Packard Sanborn, USA). The arterial line was also used for taking blood samples. In the left femoral vein a teflon catheter (type 1914 R, C.R. Bard Int., Sunderland, UK) was inserted and connected with the Sanborn recorder via a pressure transducer (Statham P 23 BB) to measure the central venous pressure (CVP).

The right jugular vein and the right femoral artery and vein were prepared for cannulation to connect the extracorporeal circuit. Via the veins cannulae (Portex arterial cannula, Hythe Kent, UK, internal diameter six or seven mm) were advanced to the superior and inferior caval veins. The right femoral artery was cannulated with an USCI arterial catheter (no 1858-S, 14 F-20 F, USCI, NJ, USA).

When cardiotomy suction was included in the experiments (series X and XI), thoracotomy was performed through the fifth right intercostal space. A rib retractor was used to expose the heart and main vessels. The azygos vein was ligated. The pericardium was opened and fixated in such a way that a well for suction of blood was created. After both caval veins had been snared, the heart was fibrillated and the right atrium and, via a puncture in the septum, the left atrium were opened. During a period of one hour the coronary blood was aspirated from the pericardial well. After termination of the cardiotomy suction period the incision in the right atrium was closed, both caval veins were opened and the heart was defibrillated. Finally the pericardium and the thorax were closed in the usual way.

2.3. VARIABLES OF THE EXTRACORPOREAL CIRCUIT

2.3.1. Tubing

2.3.1.1. Polyvinylchloride (PVC) tubing

Standard PVC tubing systems as shown in figure 2.5.1. were used. The connection between this tubing

system and the cannulae in the dog was made by PVC tubing (145 cm, \emptyset internally 9.5 mm; wall thickness 1.6 mm, Talas, Zwolle, Netherlands) and PVC connectors (Bentley, Santa Ana, USA).

2.3.1.2. Silicone rubber (SR) tubing

Standard Sucrasil® silicone rubber tubing systems as pictured in figure 2.5.2. were kindly supplied by Rhône-Poulenc, Paris, France. The venous pump insert is a thinly walled tube (\emptyset internally 19 mm, wall thickness 2.9 mm) which progressively collapses with decreasing inlet blood pressure. For positive inlet blood pressures the tubes are circularly shaped to allow maximal blood flow. Collapsing occurs at inlet pressures of -50 mm Hg. The arterial pump insert is ellipsoid in cross-section; it collapses at zero pressure and it only allows blood flows for positive inlet pressures when it has a circular shape. This standard system was connected with the arterial and venous cannulae with the same length of medical grade silicone rubber tubing (\emptyset internally 9.5 mm; wall thickness 2.9 mm) as for the in 2.3.1.1. described PVC tubing.

2.3.1.3. Silica free silicone rubber (SFSR) tubing

This tubing system is identical in shape and length with the SR tubing described in 2.3.1.2. The only difference is that all internal surfaces are covered with a silica free silicone coating. This coating, which is firmly attached to the tubing material by means of cross linking with ^{60}Co radiation, exposes a very smooth surface to the blood.

2.3.2. Blood pumps

2.3.2.1. Roller pump

Double head roller pumps (type Modul pump, Dreissen, Hellevoetsluis, Netherlands) were applied. Rotors were put in an almost occlusive position.

2.3.2.2. Rotor pump

The RPO3 blood pump (Rhône-Poulenc, Paris, France) possesses a double rotor with three rollers at 120° each, but no stator. Occlusion of the pump insert is not obtained by crushing the tubing, but by a moving fold under predetermined low tension. The design of the tubing is such that entire occlusion does not occur. The rotor pump operates slowly at maximally 50 rpm. We have used a prototype kindly provided by Rhône-Poulenc.

2.3.2.3. Centrifugal pump

A prototype centrifugal blood pump was manufactured by Medtronic, USA. It is a compact design for delivering blood flow rates up to 10 l/min without occluding surfaces. The rotor, the only moving part, is driven by a motor outside the pump chamber by

means of a magnetic coupling. The pump provides a constant pressure rather than a constant flow.

2.3.3. Oxygenators

2.3.3.1. Bubble oxygenator (BO)

As a bubble oxygenator the Temptrol disposable infant sized oxygenator Q 110 (Bentley laboratories, Inc., Irvine, California, USA) was used. Adequate oxygenation of blood was obtained with a mixture of oxygen and carbon dioxide at a gas flow rate of five l/min ($O_2:CO_2 = 95:5$).

2.3.3.2. Teflon membrane oxygenator (TMO)

The Travenol Modulung-Teflon membrane oxygenator (Travenol Lab. Int., Deerfield, Ill., USA) is a disposable oxygenator containing 2.25 m² of micro-porous Teflon membrane with plastic screen blood path spacers. The device is provided with an inflatable shim which was operated at a pressure of 200 mg Hg. A gas flow of five l/min was used ($O_2:CO_2 = 95:5$).

2.3.3.3. Kolobow MO

The Kolobow spiral coil membrane lung (type 2500 - 3B, Sci-Med Life Systems, Inc., Minneapolis, Minn., USA) consists of 2.5 m² of silicone rubber membranes, homogeneously coated with silica free silicone rubber. This blood contacting top layer of SFPSR was reinforced with immersed polyester knit fabric (Kolobow et al, 1974). As an envelope with a plastic spacer screen inside, it is spirally wound around a polycarbonate spool and encased by a silicone rubber sleeve. To oxygenate the blood a gas flow rate of five l/min was used ($O_2:CO_2 = 95:5$).

2.3.4. Cardiotomy suction

2.3.4.1. High vacuum suction

Cardiotomy suction acts as a vigorous blood-to-air contact. Standardization was achieved by defining the commonly used cardiotomy suction at the ratio of 400 ml/min of blood : 1000 ml/min of air, measured with a purgometer (Brooks-Mite DSE 2000, Hatfield, UK). This mode of suction will be referred to as high vacuum (or uncontrolled) suction.

2.3.4.2. Controlled suction

Adaption of cardiotomy suction was reached by a suction system developed by Arts et al. (1976) from the Department of Biomedical Engineering, Eindhoven University of Technology, Netherlands. In this controlled suction system air suction is virtually eliminated (ratio 400 : 0). It includes a sensor and an electronic regulator controlling the pump speed. The sensor, mounted on the sucker tip, consists of 2

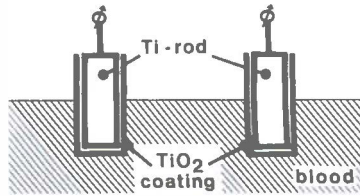

Figure 2.3.4.2.1. Principle of the sensor for controlled cardiotomy suction

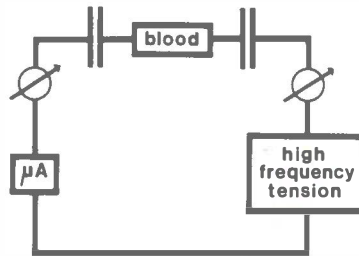

Figure 2.3.4.2.2. Electric circuit of the sensor system

titanium rods which are coated with titanium oxide (figure 2.3.4.2.1.). Titanium oxide is an electric isolator and acts as a dielectric between the titanium rods and the blood (both conductors). So capacitors are formed at both rods. Figure 2.3.4.2.2. gives the electric circuit of the sensor.

The value of the resistance (R) and the values of the capacitors (C) are dependent on the blood level. In formula:

$$R = p_1 \cdot h^{-1}$$

$$C = p_2 \cdot h \quad (h = \text{blood level}; p_1, p_2 = \text{constants})$$

By supplying a high frequency voltage to the rods with a frequency considerably higher than the cut off frequency of the device the influence of the

$$f_c = \frac{1}{2 \pi RC}$$

capacitor can be neglected. The current through the circuit is linearly dependent on the actual blood level. This signal serves as input for the regulating device, attuned to the specific aims of cardiotomy suction. The suction pump is driven by this regu-

lating device (Medical Scientific Application, Den Bosch, Netherlands), which prevents suction of air by maintaining the blood level in the pericardial well above the opening in the sucker tip.

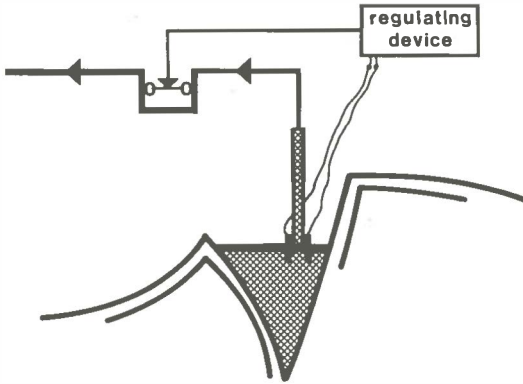

Figure 2.3.4.2.3. Schematic presentation of the controlled suction system

2.4. EXPERIMENTAL SERIES

Table 2.4. lists the series of experiments performed. Variables in the extracorporeal circuit are the tubing (polyvinylchloride (PVC), silica free silicone rubber (SFSR) or silicone rubber (SR)), the type of pump (roller pump, rotor pump or centrifugal pump), the oxygenator (bubble oxygenator (BO), Teflo membrane oxygenator (TMO) or Kolobow membrane oxygenator (Kolobow MO)), and the suction (controlled or high vacuum suction). More details are given in chapter 2.3.

Series	Tubing	Pump	Oxygenator	Suction
	Chapter 3	Chapter 4	Chapter 5	Chapter 6
I	- PVC	+ roller pump		
II	- SFSR	+ rotor pump		
III	- SR	+ rotor pump		
IV	- SFSR	+ roller pump		
V	- SFSR	+ centrifugal pump		
VI	- PVC	+ roller pump	+ BO	
VII	- PVC	+ roller pump	+ TMO	
VIII	- SFSR	+ rotor pump	+ TMO	
IX	- PVC	+ rotor pump	+ Kolobow MO	
X	- PVC	+ roller pump	+ TMO	+ controlled suction
XI	- PVC	+ roller pump	+ TMO	+ high vacuum suction

Table 2.4. Series of experiments performed

2.5. EXPERIMENTAL SETUP

In all experiments the arterial line contained an electromagnetic flow probe (emf) (Transflow 600 flowmeter, Skalar, Delft, Netherlands) to measure the blood flow through the ECC. This nonpulsatile flow was kept as closely as possible to 100 ml/min/kg and monitored on the Sanborn recorder. Such flow rates of about 3000 ml/min are effective for total cardiopulmonary bypass in dogs.

The polyvinylchloride (PVC) tubing system is a standard commercially available circuit (Travenol, Morton Grove, Ill., USA) to be used in conjunction with the TMO membrane oxygenator. This set consists of 470 cm of PVC tubing (\emptyset internally 12.7 or 9.5 mm) and two pump inserts made of silicone rubber with a length of 45 cm each (\emptyset 12.7 mm), venous and arterial reservoirs and a heat exchanger (Miniprime, Travenol) interconnected in the circuit to regulate blood temperature. The recirculation line, included in the system for priming purposes, was clamped during extracorporeal circulation. Lengths and diameters of this standard system are given in the box of the schematic representation of the total setup (figure 2.5.1.).

The described Travenol circuit was applied in all experiments in which PVC tubing was incorporated (series I, VI, VII, X and XI). The connection between the arterial and venous cannulae and this tubing system has been described in 2.3.1.1.

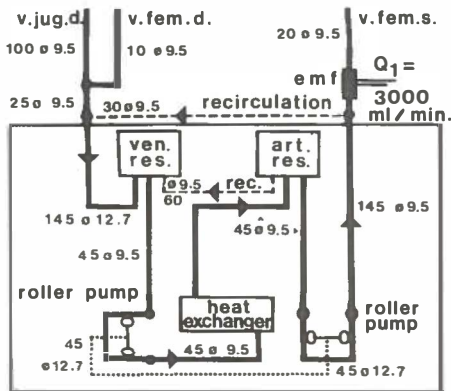

Figure 2.5.1. Schematic representation of the experimental setup for the polyvinylchloride (PVC) tubing experiments (series I). An electromagnetic flow probe (emf) controls the flow through the circuit of which length (in cm) and internal diameter (in mm) for the various parts are given. The circuit within the box represents the standard Travenol PVC tubing system.

The standard silica free silicone rubber (SFSR) and the geometrically identical silicone rubber (SR) tubing systems (length 715 cm, ϕ internally 9.5 mm and 25.4 mm for the pump inserts), used in the series II, III, IV, V, VIII, and IX, have been described in 2.3.1.2. and 2.3.1.3.. The connection lines to the cannulae were of the same SFSR or SR material as the respective tubing systems. In the standard circuits parts of the arterial and venous lines contained built-in heating wires, which were powered by a 6 V, 12 A electric supply. As in the PVC circuit an electromagnetic flow probe in the arterial line measured the blood flow (3000 ml/min) through the extracorporeal circuit. Figure 2.5.2. shows the schematic representation of this setup.

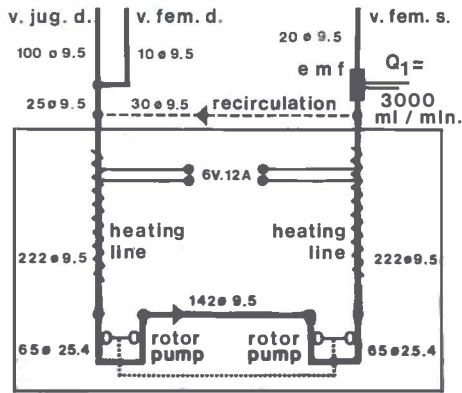

Figure 2.5.2. Schematic representation of the experimental setup for the silica free silicone rubber (SFSR) and silicone rubber (SR) tubing systems (series II, III). An electromagnetic flow probe (emf) controls the flow through the circuit, of which length (in cm) and internal diameter (in mm) for the various parts are given.

In the centrifugal pump series (series V) an otherwise identical SFSR circuit was connected to the centrifugal pump (see 2.3.2.3.) instead of to the roller pump or the rotor pump. The pump was interconnected in the circuit half way between both pump inserts (see figure 2.5.3.).

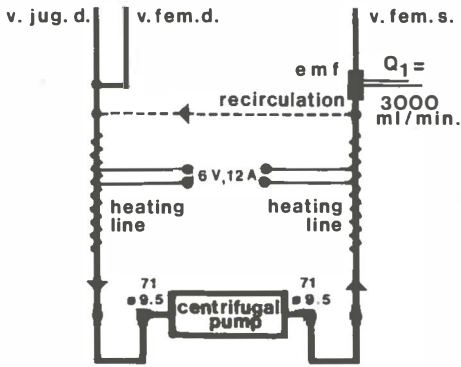

Figure 2.5.3. Schematic representation of the experimental setup for the centrifugal pump series (series V). See for legends figure 2.5.2.

In series VII a membrane oxygenator was incorporated in the standard PVC tubing system of figure 2.5.1. This situation is presented in figure 2.5.4.

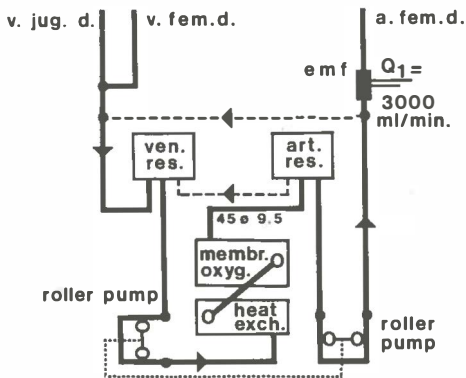

Figure 2.5.4. Schematic representation of the experimental setup for a membrane oxygenator (TMO) in the standard PVC tubing system. See for further legends figure 2.5.1.

Both in series VIII and IX a membrane oxygenator was interconnected in the SFSR tubing system (figure 2.5.2.). Figure 2.5.5. shows the schematic representation of this setup.

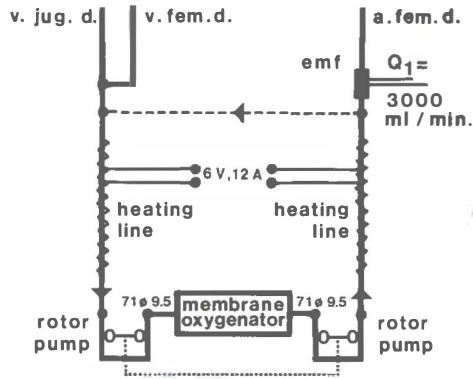

Figure 2.5.5. Schematic representation of the experimental setup for a membrane oxygenator (MO) in SFSR tubing system. See for further legends figure 2.5.2.

Figure 2.5.6. represents the situation of series VI in which a bubble oxygenator (BO) was used. For reasons of comparison the standard Travenol PVC tubing system for the membrane oxygenators was employed. In this open to air ECC system a third roller pump had to be placed after the BO to overcome the pressure of the arterial reservoir.

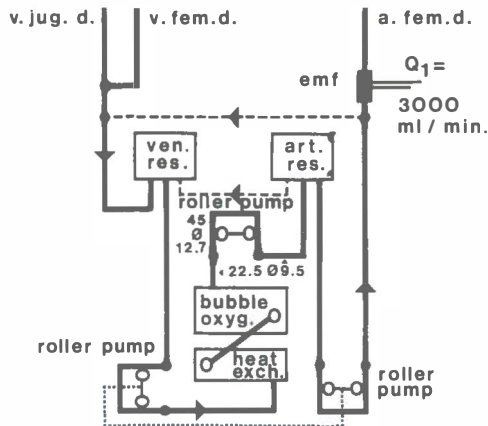

Figure 2.5.6. Schematic representation of experimental setup for a bubble oxygenator (BO) in the standard PVC tubing system (series VI). After the BO a third roller pump is interconnected to overcome the pressure of the arterial reservoir. See figure 2.5.1. for further legends.

In the cardiotomy suction series X and XI the setup of the MO with the PVC tubing system (figure 2.5.4.)

was extended with the suction device (see paragraphs 2.4.4.1. and 2.4.4.2.) in combination with a cardiomy reservoir (Bentley disposable cardiomy reservoir Q 120, Irvine, California, USA). This setup is represented in figure 2.5.7.

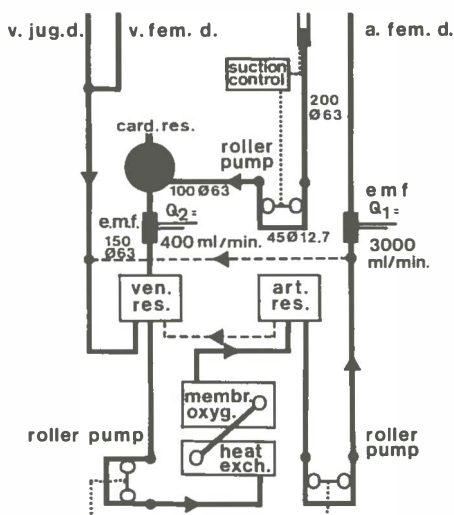

Figure 2.5.7. Schematic representation of the experimental setup for a membrane oxygenator (MO) in the PVC tubing system with a cardiomy suction system (series X and XI).

2.6. EXPERIMENTAL PROTOCOL

time	
1. 0.00	venepuncture blood sample preoperative I
2.	premedication by intramuscular injection of 50 mg pethidine hydrochloride and 0.5 mg atropine sulphate
3. 0.10	induction of anesthesia with 30 mg/kg BW pentothobarbital sodium
4. 0.20	intubation
5.	continuation of anesthesia with fluothane 0.5 % in N ₂ O 4 l/min and O ₂ 2 l/min
6.	bleeding time test
7. 0.30	preparation of arteries and venes
8. 0.50	sample ACT 1 (preoperative)
9. 0.55	heparinization 100 IU/kg BW intravenously
10. 1.00	sample ACT 2
11.	heparinization 100 IU/kg BW
12. 1.10	sample ACT 3

- | | | |
|-----|-------------|--|
| 13. | | additional heparinization if necessary |
| 14. | 1.20 | cannulation of arteries and venes |
| 15. | 1.30 | connection of primed extracorporeal circuit and calibrations (flow probe, SAP, CVP) |
| 16. | 1.55 | sample ACT 4, administration of heparin |
| 17. | 2.00 | blood sample preoperative II = sample 0 mins |
| 18. | | sample of priming fluid |
| 19. | | start of ECC |
| 20. | 2.05 | blood sample 5 mins |
| 21. | 2.15 | blood sample 15 mins |
| 22. | 2.30 | blood sample 30 mins |
| 23. | 3.00 | blood sample 60 mins |
| 24. | | blood sample ACT 5, administration of heparin |
| 25. | 4.00 | blood sample 120 mins |
| 26. | | blood sample ACT 6 |
| 27. | | end of ECC, return of calculated amount of blood from extracorporeal circuit into the animal |
| 28. | 4.10 | intravenous administration of protamine hydrochloride |
| 29. | 4.20 | blood sample ACT 7 |
| 30. | 4.30 | blood sample 150 mins |
| 31. | 5.00 | blood sample 180 mins |
| 32. | 6.00 | blood sample 240 mins |
| 33. | | blood sample ACT 8 |
| 34. | | bleeding time test |
| 35. | 6.15 | termination of anesthesia |
| 36. | 1 day p.o. | blood sample day 1 |
| 37. | 2 day p.o. | blood sample day 2 |
| 38. | 3 day p.o. | blood sample day 3 |
| 39. | 4 day p.o. | blood sample day 4 |
| 40. | 5 day p.o. | blood sample day 5 |
| 41. | 6 day p.o. | blood sample day 6 |
| 42. | 7 day p.o. | blood sample day 7 |
| 43. | 14 day p.o. | blood sample day 14 |
| 44. | 21 day p.o. | blood sample day 21 |

In the cardiotomy suction series X and XI thoracotomy was performed, whereas in the other series a closed chest cardiopulmonary bypass was employed. Suction was instituted after 30 mins of ECC for a period of one hour within the total bypass period of two hours and additional samples were taken at 35 and 45 mins. The thorax was closed during the last 30 mins before the end of ECC.

Blood samples were taken at the indicated moments to perform the following assays:

		ADP aggregation of thrombocytes	number of erythrocytes	number of leukocytes	number of thrombocytes	bleeding time	hematocrit	hemoglobin	plasma hemoglobin	SRE	fibrinogen	APTT, PT, RT, TT
preoperative I		x	x	x	x	x	x	x	x	x	x	x
preoperative II		x	x	x	x	x	x	x	x	x	x	x
priming fluid		x	x	x	x	x	x	x				
ECC	mins											
	5	x	x	x	x	x	x	x				
	15	x	x	x	x	x	x	x	¹			
	30	x	x	x	x	x	x	x				
	35 ¹	x	x	x	x	x	x	x				
	45 ¹	x	x	x	x	x	x	x				
	60	x	x	x	x	x	x	x				
	120	x	x	x	x	x	x	x	x	x	x	x
recovery period	150	x	x	x	x	x	x					
	180	x	x	x	x	x	x					
	240	x	x	x	x	x	x	x	x	x	x	x
	days											
	1	x	x	x	x	x	x	x	x	x	x	x
	2	x	x	x	x	x	x	x	x	x	x	x
	3	x	x	x	x	x	x	x	x	x	x	x
	4	x	x	x	x	x	x	x				
	5	x	x	x	x	x	x	x				
	6	x	x	x	x	x	x	x				
	7	x	x	x	x	x	x	x	x	x	x	x
	14	x	x	x	x	x	x					
	21	x	x	x	x	x	x					

Table 2.6. Time scheme of the hematological assays.

¹ for the cardiotomy suction series only

2.7. LABORATORY METHODS

All blood samples were collected in disposable syringes; for venepunctures siliconized disposable needles 0.9 x 40 mm were used. The blood samples were kept in plastic tubes covered with Parafilm.

Blood for cell counts, hemoglobin and hematocrit measurements was immediately anticoagulated with disodium edetate, available in a ratio of 6 mg to 2.5 ml of blood in sequestrene cups. Blood for thrombocyte aggregation and fibrin formation studies was mixed with 0.1 volume of 3.08 % w/v trisodium citrate dihydrate in plastic tubes covered with Parafilm.

Platelet poor plasma (ppp) was prepared in a Heraeus Christ type 1730 centrifuge (Osterode am Harz, FRG) at 2000 x g (3000 rpm) for 10 minutes. Platelet rich plasma (prp) was prepared at 250 x g (1000 rpm) for 10 minutes.

All assays were performed immediately except for the tests on fibrin formation and plasma hemoglobin. Plasma for these tests was frozen and stored at -20 °C and assayed simultaneously at a later date.

2.7.1. Number of thrombocytes, leukocytes and erythrocytes

2.7.1.1. Technique

Thrombocytes, leukocytes and erythrocytes were counted in duplo with an electronic particle counter (Coulter Counter, Type Fn, Coulter Electronics Ltd., Dunstable, UK) calibrated for canine blood cells. Isoton[®] was used for dilution. The average of the two counts (maximal allowed difference 3 %) was taken as the value of the sample. The values are expressed as percentages of the initial value.

2.7.1.2. Control of the electronic particle counting: microscopic counting versus electronic counting of thrombocytes

By determining the correlation between electronic particle counting and phase contrast microscopy counting according to Feissly and Lüdin (1949) this calibration was checked at regular intervals. An example of the correlation between both methods of thrombocyte counting ($r^2 = 0.993$) is given in figure 2.7.1.2.

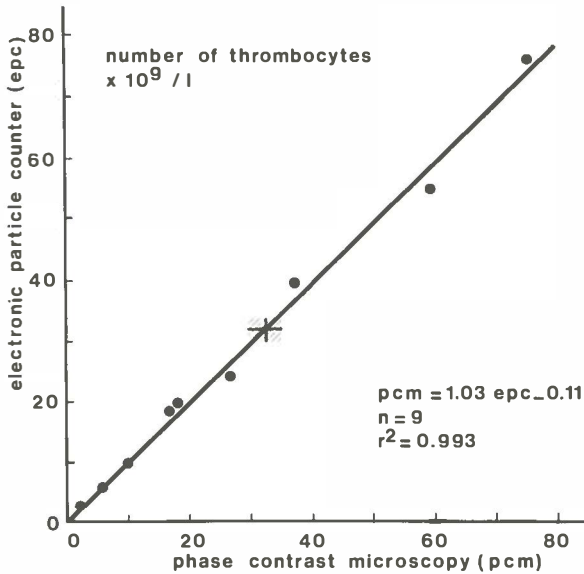

Figure 2.7.1.2. Correlation between phase contrast microscopic counting (pcm) and electronic particle counting (epc) of thrombocytes.

2.7.2. Function of thrombocytes

2.7.2.1. Technique

To assess the function of the thrombocytes platelet aggregation was performed according to the method of Born (1962, 1963) using a modified Vitatron UC 200 (Dieren, Netherlands) spectrophotometer connected to a Vitatron universal lin/log UR 300 recorder. Aggregation was induced by ADP in a final concentration of 5 $\mu\text{g/ml}$ (1.2×10^{-5} M). This amount of ADP is higher than the final concentration of 0.8-1.2 $\mu\text{g/ml}$ ($2-3 \times 10^{-6}$ M) to which human prp samples are normally exposed (Blakely, 1972; Grabowski et al., 1976). The tests were carried out at room temperature. Thrombocyte function was expressed by the maximal optical density loss (ODmax) as indicated in figure 2.7.2.1., as a percentage of the preoperative value. These related percentages of ODmax yield the same results as the cotangent of the initial slope ($\cot \alpha$), also expressed as a percentage of the preoperative value.

ADP induced platelet aggregation: parameters

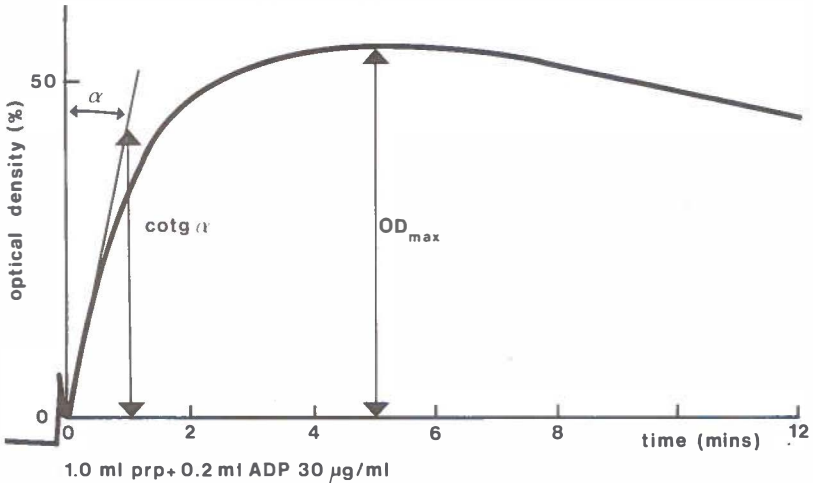

Figure 2.7.2.1. Parameters of ADP induced thrombocyte aggregation

2.7.2.2 Thrombocyte number versus function nomogram

Laboratory procedures for measuring ADP aggregation curves under standardized conditions of thrombocyte numbers involve manipulations to concentrate or to dilute the prp samples in attempts to equalize numbers. Since every manipulation may result in damage to the thrombocytes, a different approach has been chosen to correct differences in thrombocyte numbers. Its principle is correction by calculation afterwards rather than correction by concentration or dilution of the prp.

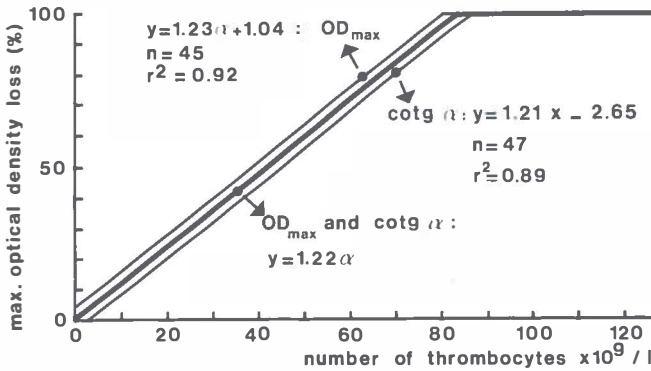

Figure 2.7.2.2. The thrombocyte function nomogram

In serial dilutions of prp from normal dogs thrombocyte aggregations were determined and ODmax and cotg α , expressed as proportions of their predilution values, were plotted against the corresponding numbers of thrombocytes. This nomogram (figure

2.7.2.2.) consists of two closely placed parallel straight lines for thrombocyte counts under $82 \times 10^9/l$. Since for practical purposes the two lines virtually coincide, they can be shown as one straight line. Thus, for low thrombocyte concentrations there is a linear relationship between thrombocyte numbers and functions. It is also seen that for concentrations of over $82 \times 10^9/l$, the aggregation parameters are not influenced by increasing numbers. Thus this nomogram makes it possible to compare aggregation curves with different thrombocyte concentrations without any manipulation. Similar experiments were performed by Levine (1976), who measured the effect of thrombocytopenia on the determination of platelet aggregation in men. He found that the aggregation induced by ADP was reproducible at decreasing platelet counts until numbers as low as $50 \times 10^9/l$, thus confirming the principle of the nomogram.

2.7.3. Bleeding time

Primary bleeding times were determined in duplicate in the upper hindleg of the dog according to the method of Borchgrevink et al. (1958). The incisions had a length of 10 mm and a depth of 2.5-3 mm.

2.7.4. Hematocrit, hemoglobin and plasma hemoglobin

Hematocrit values were determined with a high speed hematocrit centrifuge using heparinized hematocrit capillaries.

Hemoglobin levels were determined by converting red cell hemoglobin into cyanmethemoglobin with Zaptoglobin[®], measuring the optical density of the solution at $540 \mu m$ using a Vitatron universal photometer (Dieren, Netherlands) and comparing it to a known standard (van Kampen et al., 1961). Hemoglobin concentrations are given in mmol/l blood.

Plasma hemoglobin concentrations ($\mu mol/l$) were measured by means of the peroxide-method described by Lee Kum Tatt et al. (1969).

The hematocrit values (0-240 mins) have been used to correct results of cell counts, hemoglobin, plasma hemoglobin, and fibrinogen, thus rendering these parameters independent of hemodilution during the day of the experiment.

2.7.5. Fibrin formation

Fibrinogen levels were determined according to the method of Leclerc and Khodabandeh (1953), prothrombin times (PTT) according to Quick (1966), activated partial thromboplastin times (APTT) according to Proctor and Rapaport (1961), thrombin times (TT)

according to Vermijlen and Verstraete (1961), and reptilase times (RT) according to Soria et al. (1969). PT, APTT, RT, and TT tests were performed on a Dual channel coagulometer (Clottimer, Model 202A, Mechrolab, Santa Rosa, Cal., USA).

2.7.6. Sedimentation rate of the erythrocytes (SRE)

The sedimentation rate of the erythrocytes was assessed according to the method of Westergren (1924).

2.7.7. Body temperature

Body temperature was measured rectally while with an Ellab (Kopenhagen, Denmark) thermometer during the day of the experiment, while during the following days conventional mercury thermometers were used.

2.7.8. Normal hematological values in dogs

Normal hematological values were calculated in 30 healthy nontreated dogs using the described methods. The resulting mean values are given in table 2.7.8. together with their standard deviation. Comparative values are given from the work of Bruck (1977), Spurling (1977), Grabowski et al. (1977), Schalm et al. (1975), Schermer (1967), and Melby et al. (1976).

For all parameters the values of the mean ± 1 sd are considered to form the normal range to which the dogs had to correspond at the time of the hematological examination before the experiment. Exclusion from the experiments followed if blood cell counts, thrombocyte function, bleeding time or SRE were not within this normal range.

2.8. STATISTICAL ANALYSIS

Data collection was performed by means of the WESP statistical package (van der Week, 1977) on a CDC Cyber 6600 computer. Statistical analysis of the results included the Student-t test for two means and the paired Student-t test. P values ≤ 0.05 were considered to be statistically significant.

Groningen

parameter	dimension	mean	range	Spurling	Grabowski	Schalm	Schermer	Melby	Bruck
number of thrombocytes	10 ⁹ /l	214	151-277	240-382	200-340	200-500	165-378	265-319	200-500
number of leukocytes	10 ⁹ /l	10	6.5-13.5	5-18	11.6-17.6	6-17	7-11.4	9-14	6-17
number of erythrocytes	10 ¹² /l	5.85	4.97-6.73	4.25-8.5	-	5.5-8.5	5.58-6.77	5.8-7.6	5.5-8.5
ODmax	%	52	35-69	-	-	-	-	-	-
bleeding time	sec	73	90	-	-	-	90-150	-	-
hematocrit	l/l	0.51	0.47-0.55	0.34-0.58	0.36-0.45	0.37-0.55	0.31-0.60	0.39-0.5	0.37-0.55
hemoglobin	mmol/l	10.7	9.7-11.7	6.5-13.0	-	7.5-11.0	6.6-12.4	9.7-10.9	7.5-11.2
plasma hemoglobin	μmol/l	1.2	2.1	-	1.9-3.3	-	-	-	-
SRE	mm	1.7	3.7	0.5-1.5	-	5	2	-	-
body temperature	°C	38.5	38.1-38.9	-	-	-	-	-	-
fibrinogen	g/l	1.89	1.40-2.37	-	-	2.0-4.0	-	-	2.0-4.0
APTT	sec	26.4	21.4-31.5	-	-	-	-	-	-
PTT	sec	9.1	8.1-10.1	6.5-9.5	-	-	6.6-7.6	-	-
RT	sec	11.9	10.4-13.4	-	-	-	-	-	-
TT	sec	10.3	9.1-11.5	-	-	-	-	-	-

Table 2.7.8. Normal hematological values in dogs

CHAPTER 3: INFLUENCE OF THE CIRCUIT MATERIAL

3.1. PREFACE

This chapter will describe the general behaviour of blood components when exposed to the basic elements of an extracorporeal circuit, tubing and pumps, and compares three different tubing materials: PVC, SFSR and SR.

3.2. SERIES I: PVC TUBING

3.2.1. Introduction

Paragraph 3.2. presents the hematological changes caused by the relatively simple extracorporeal circuit consisting of polyvinylchloride (PVC) tubing material and a double head roller pump, described in chapter 2, figure 2.5.1., as the standard Travenol PVC extracorporeal circuit. In this series of six experiments all dogs survived and no complications were encountered.

In all following figures the two hour period of extracorporeal circulation is represented by the horizontally shaded area.

During the day of the experiment (0-240 mins) the presented results of cell counts, hemoglobin, plasma hemoglobin, and fibrinogen are independent of hemodilution because of correction for changes in the hematocrit.

3.2. Series I: PVC tubing

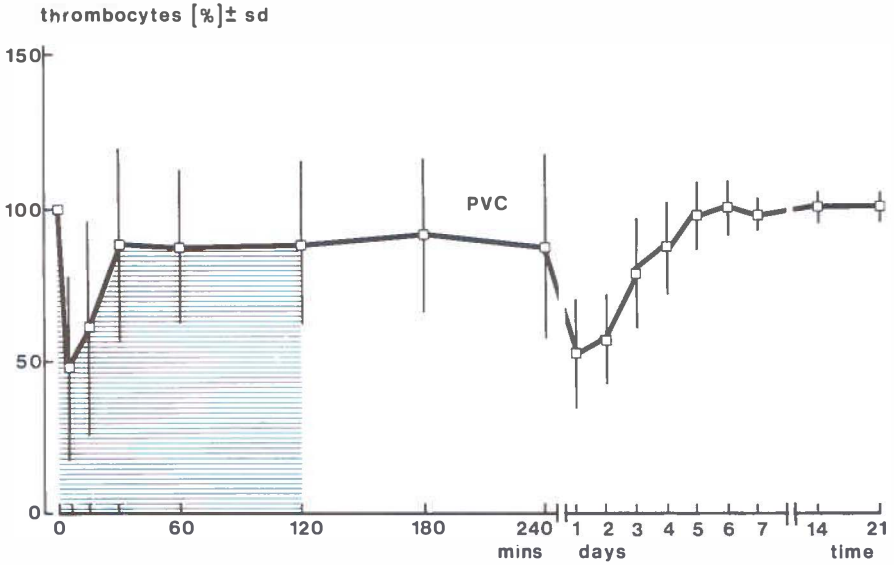

Figure 3.2.2. Percentage of thrombocyte number

Within five minutes after starting ECC the number of circulating thrombocytes, corrected for changes in hematocrit, sharply decreased to 50 % of the initial value. After this initial dip the number increased in 30 minutes and stabilized around 88 %. After the disconnection of the circuit the number of thrombocytes did not change immediately.

However, a clear secondary dip was observed on the first day after the operation, followed by a gradual restoration. The preoperative mean value was reached on day five and in the subsequent period no changes in number were observed.

3.2. Series I: PVC tubing

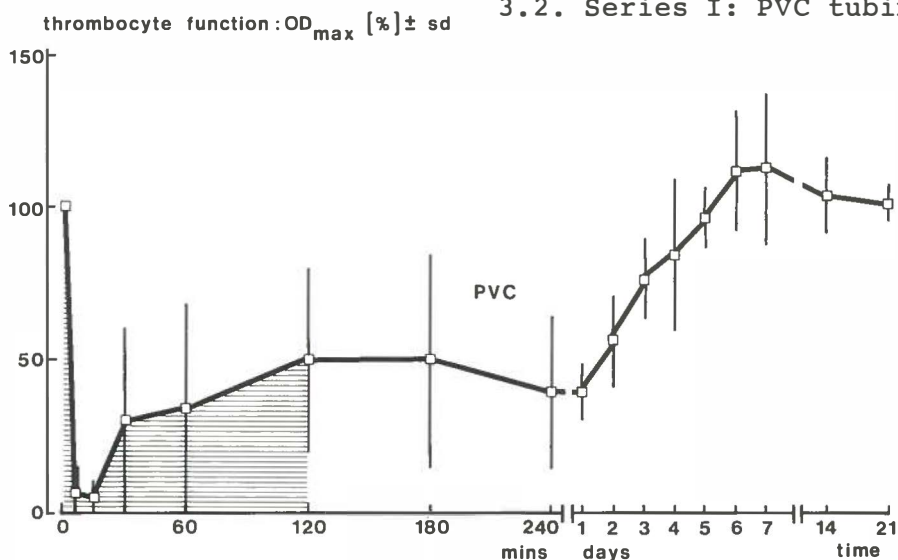

Figure 3.2.3. Percentage of thrombocyte function: OD_{max}

The initiation of extracorporeal circulation resulted in an immediate disappearance of thrombocyte function. After 30 minutes the function had recovered to 32 % reaching 50 % at the end of the ECC period. Further restoration of the OD_{max} values started from the first day after the operation. The OD_{max} was normal on day five and showed values of over 100 % on days six and seven. On days 14 and 21 about preoperative OD_{max} values were measured.

3.2. Series I: PVC tubing

bleeding time [mins] \pm sd

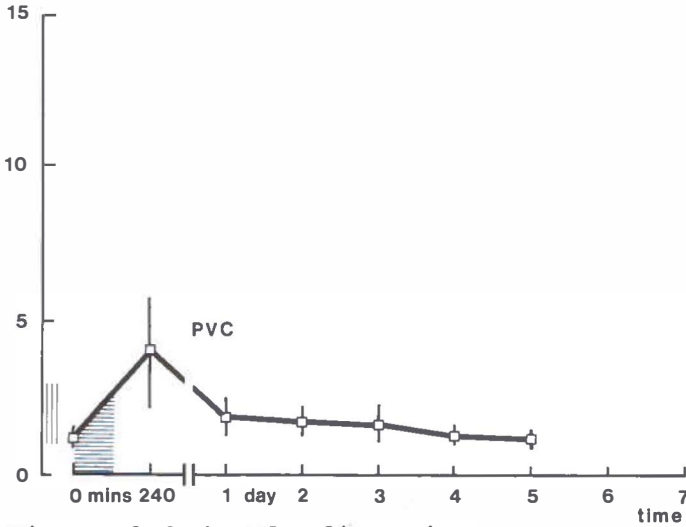

Figure 3.2.4. Bleeding time

Two hours after the ECC period the outcome of the bleeding time was slightly but significantly ($p < 0.05$) lengthened from 1 to 4 minutes. (The normal range of 1-3 mins is indicated in the figure by the vertically shaded area.) On the following days the bleeding times had returned to normal values.

3.2. Series I: PVC tubing

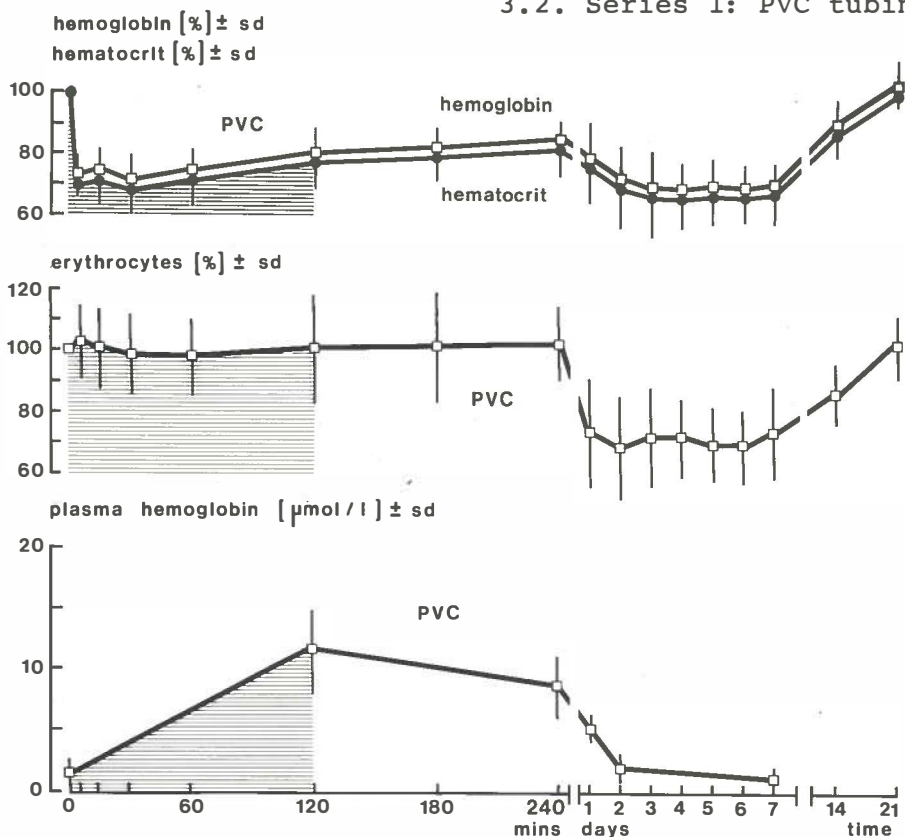

Figure 3.2.5. Percentages of hemoglobin, hematocrit and erythrocyte number, and level of plasma hemoglobin

As a result of the priming of the circuit with 2 l diluted blood with a hematocrit of 0.23 l/l both hemoglobin and hematocrit initially decreased to 70 %, but gradually increased during the day of the experiment. After the experiment the changes in hemoglobin and hematocrit reflected the changes in the percentage of erythrocyte number. Preoperative values were reached after three weeks.

During the ECC period and the first hours of recovery no changes in the erythrocyte number, corrected for changes in hematocrit, were measured. In the first week after the experiment the number decreased to about 70 %. After one week a gradual restoration was observed until the normal value was reached in the third week.

The level of plasma hemoglobin increased from 1.7 $\mu\text{mol/l}$ preoperatively to a maximum of 11.9 $\mu\text{mol/l}$ after two hours of ECC. Thereafter the level of plasma hemoglobin gradually decreased and reached the preoperative level on day two.

3.2. Series I: PVC tubing

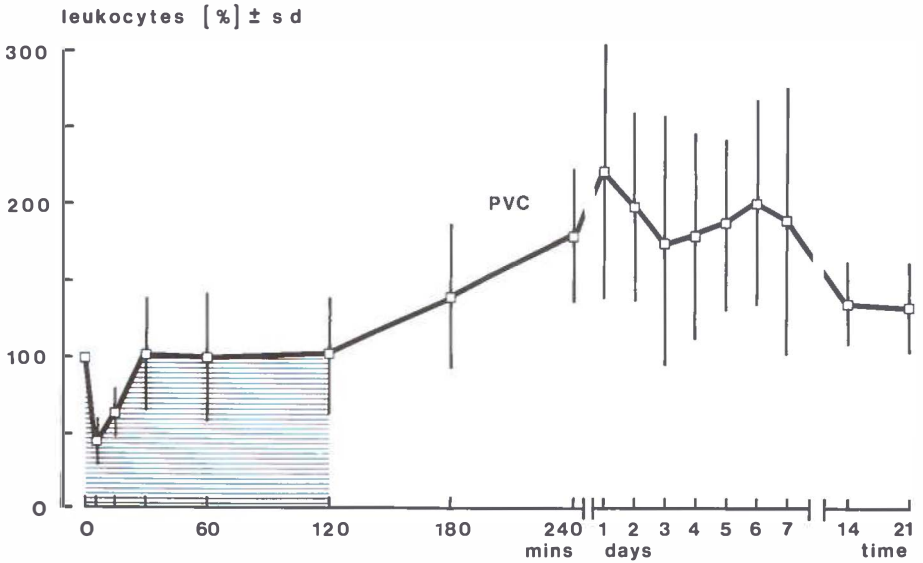

Figure 3.2.6. Percentage of leukocyte number

During the early minutes of ECC the number of circulating leukocytes decreased to 41 %. The preoperative level was regained within 30 minutes and remained stable until the end of the perfusion period. After the disconnection of the circuit a gradual increase in number was observed with a maximum of 220 % on day one after the operation. Hereafter the leukocyte number decreased to 174 % on day three, followed by another maximum of 200 % on day six and, finally, a gradual normalization within two weeks.

For this parameter the differences between individual dogs resulted in relatively large standard deviations.

3.2. Series I: PVC tubing

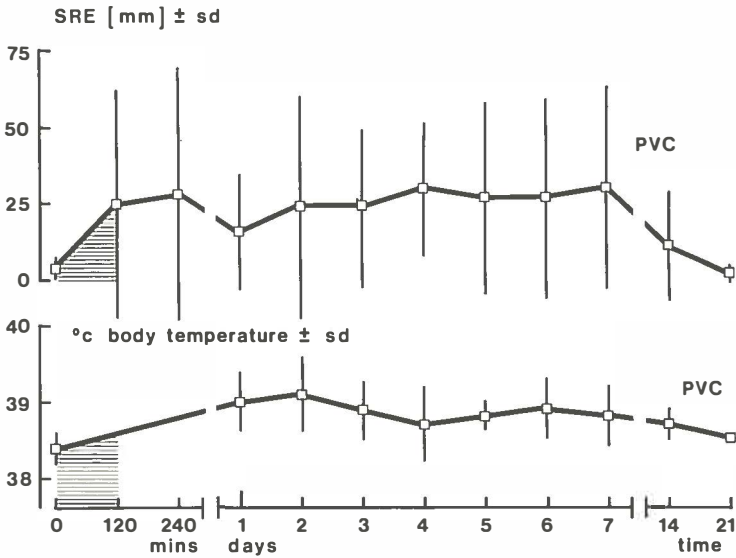

Figure 3.2.7. SRE and body temperature

The sedimentation rate of the erythrocytes (SRE) showed an increased value of about 25 mm/h at the end of the ECC period, which elevation lasted the first week. After 14 days the SRE had decreased and a normal rate was measured on day 21.

The body temperature showed values of about 39°C during the first days after the experiment and returned to the normal range of about 38.5°C after a week.

3.2. Series I: PVC tubing

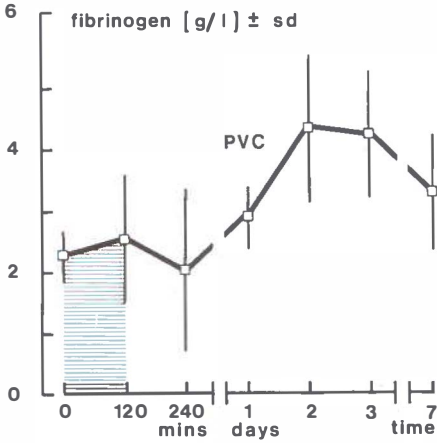

Figure 3.2.8. Fibrinogen

During ECC the fibrinogen level, corrected for changes in hematocrit, showed minor changes. In the recovery period the level increased to a maximal value of 4.3 g/l on day two. After this maximum it decreased to a slightly elevated level of 3.3 g/l on day seven after the experiment.

3.2. Series I: PVC tubing

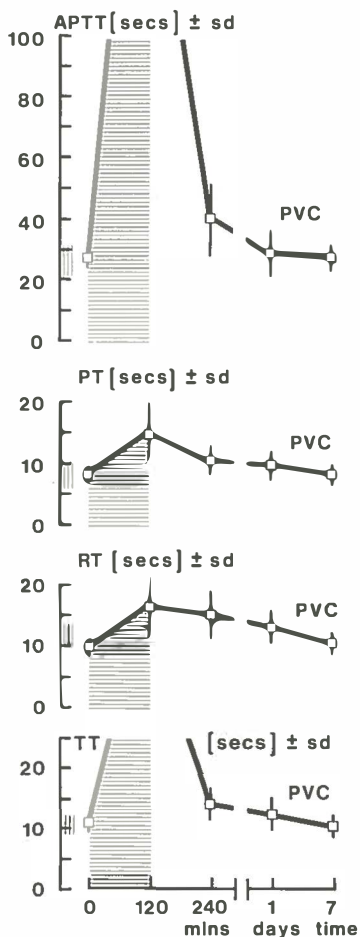

Figure 3.2.9. Activated partial thromboplastin time (APTT), prothrombin time (PTT), reptilase time (RT), and thrombin time (TT)

Two of the clotting parameters were influenced by the systemic heparinization during the experiment: APTT and TT were extremely lengthened during the period of ECC.

At the end of the day and day one after the operation APTT showed lengthened values of 41 and 36 secs respectively, while on day seven preoperative values were measured.

TT showed minor increases to about 12 secs during the early period after ECC and had normalized on day seven.

PTT had increased to 15 secs at the end of the ECC period. This value decreased to 11 secs after 240 minutes and on day one after the experiment. Preoperative values were found on day seven.

RT increased during the bypass period to about 17 secs. At the end of the day of the experiment and on day one the RT had decreased, while preoperative values were measured on day seven.

3.3. SERIES IV: SFSR TUBING VS SERIES I: PVC TUBING

3.3.1. Introduction

Paragraph 3.3. describes the results of the experiments with the silica free silicone rubber (SFSR) tubing, as described in chapter 2, figure 2.5.2., compared with the in 3.2. presented experiments with the standard PVC tubing. Both types of tubing were employed with the same double head roller pump. The parameters SRE, body temperature, fibrinogen and clotting will not be described further, because paragraph 3.2. revealed they do not provide additional information. The changes in hemoglobin, which yield essentially the same results as the parameter of the hematocrit, will also be omitted in the further descriptions.

To facilitate statistical analysis results are given as mean values together with their standard error of the mean (sem).

In both circuit series no complications were encountered: both groups of six dogs were long term survivors.

3.3. Series IV: SFSR tubing

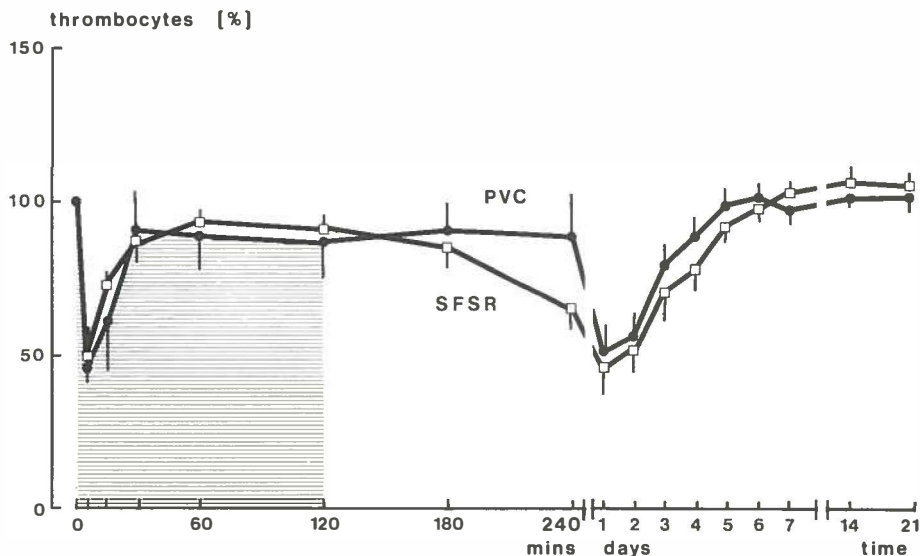

Figure 3.3.2. Percentage of thrombocyte number

An extracorporeal circuit composed of silica free silicone rubber (SFSR) tubing showed the same initial dip in thrombocyte numbers as was found in the PVC tubing group. During ECC there was also a comparable restoration to a stable level of about 90 %. However, after the disconnection of the circuit a marked decrease in number appeared in the SFSR group, whereas an unchanged level persisted in the PVC tubing group. After 240 mins the difference between the groups was not statistically significant. In both groups a secondary dip to about 50 % was seen on the first day after the experiment. Restoration to normal values followed similar patterns. Approximately preoperative numbers were measured from day six onwards.

3.3. Series IV: SFSR tubing

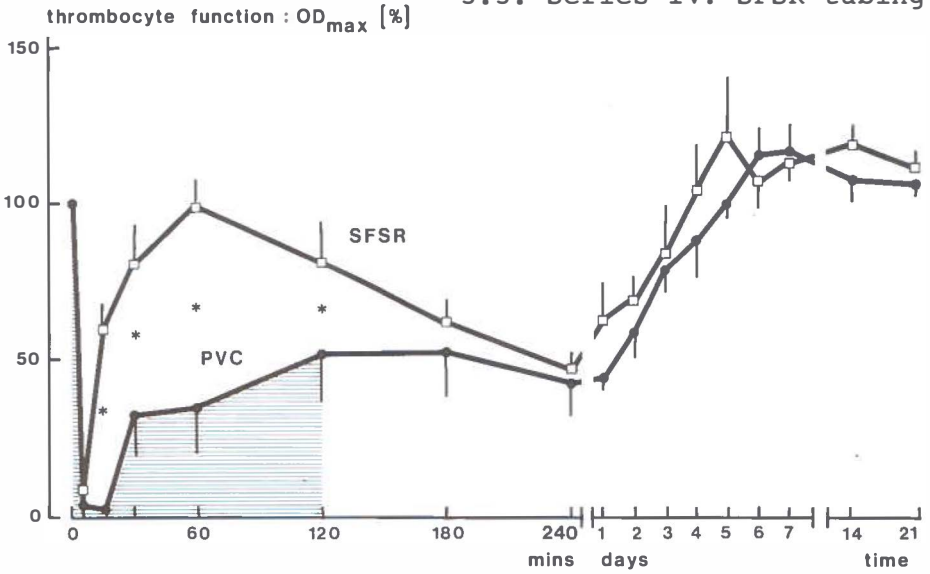

Figure 3.3.3. Percentage of thrombocyte function: OD_{max}

After five mins of ECC the SFSR tubing group showed a similar, almost complete disappearance of OD_{max} as observed in the PVC tubing group. However, a rapid restoration to a normal function was achieved in the SFSR tubing group after 60 mins, whereas the function in the PVC group remained low. During this period the differences between both groups were statistically significant ($p < 0.01$). During the further course the function decreased gradually to 80 % at the end of the ECC period and reached a minimum value of 44 % after 240 mins, almost equal to the minimum in the PVC group. After these minima in both groups normal values were found after five days.

3.3. Series IV: SFSR tubing

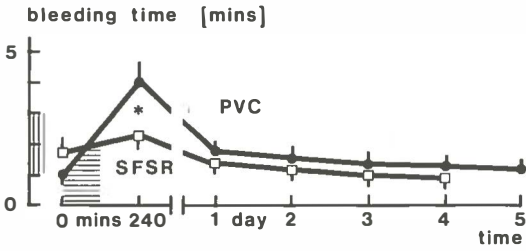

Figure 3.3.4. Bleeding time

In the SFSR tubing group the bleeding time remained within the normal range during the whole experiment. In the PVC group the bleeding time was slightly but significantly prolonged (4 mins) at the end of the day of the experiment ($p < 0.05$).

3.3. Series IV: SFSR tubing

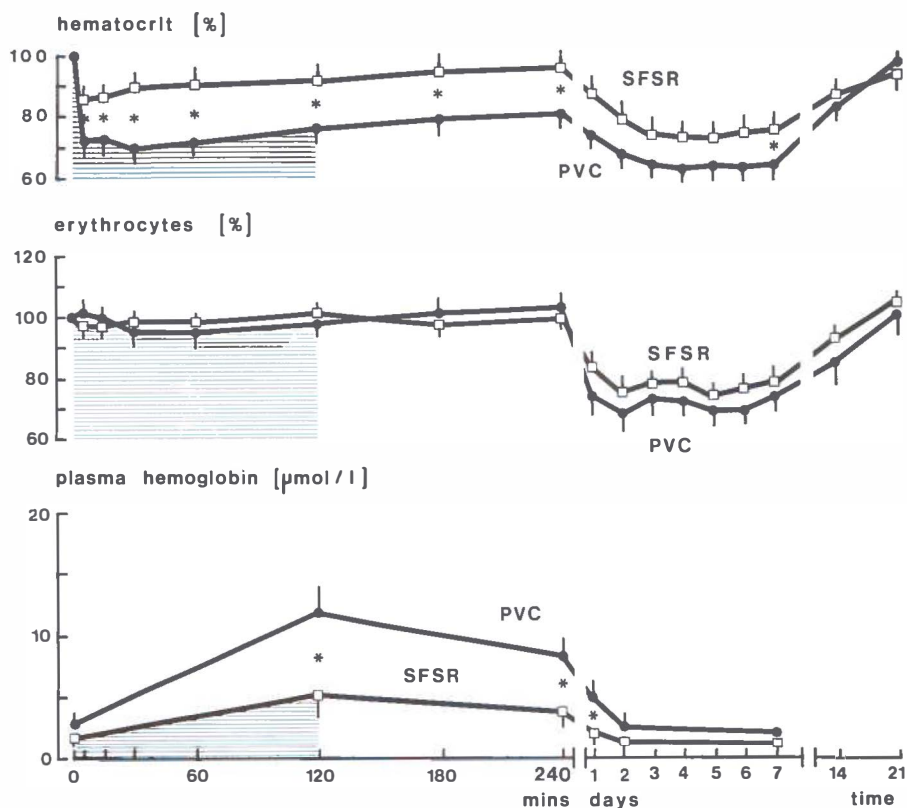

Figure 3.3.5. Percentages of hematocrit and erythrocyte number, and level of plasma hemoglobin

Significant differences between the SFSR and the PVC tubing groups were detected for the hematocrit, because in the SFSR tubing group the circuit was primed with 1 liter of diluted blood (see 2.2.4.) in contrast to 2 l in the PVC tubing group. During the day of the experiment the hematocrits in the SFSR tubing group were about 15 % higher. This higher level was maintained in the further course of the postoperative period although the difference was only significant on day seven. Normal values were reached in both groups after three weeks.

During the day of the experiment in the SFSR tubing group the number of erythrocytes, corrected for changes of hematocrit, was slightly decreased. After disconnection values of about 100 % were measured. In the days after the experiment the changes in the percentage of erythrocytes revealed a decrease of about 25 %, followed by a gradual improvement after the first week. The preoperative value had returned

on day 21. In the SFSR tubing group all values were about 5-10 % higher than in the PVC tubing group, but these differences were not significant.

After 120 mins of ECC plasma hemoglobin in the SFSR tubing group remained at a significantly lower level ($5.2 \mu\text{mol/l}$) as compared with the PVC tubing groups ($11.9 \mu\text{mol/l}$). These values decreased towards normal from day two onwards. Significant differences between the groups were still present on the first and second day after the experiment.

3.3. Series IV: SFSR tubing

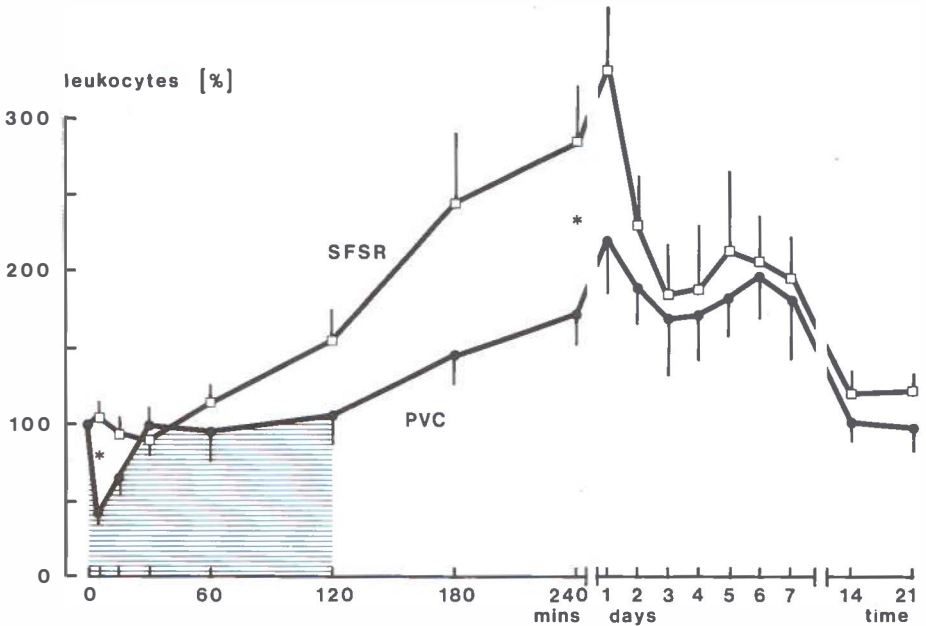

Figure 3.3.6. Percentage of leukocyte number

During the early phase of the ECC period the number of circulating leukocytes showed no initial decrease, but remained at a level of about 100 %. From 30 mins onwards a gradual increase was measured until a maximum of 332 % was reached on day one after the experiment in contrast to 220 % in the PVC tubing group. In the SFSR tubing group the leukocytosis rapidly decreased and both groups showed similar courses from the third day. Significant differences were measured after 5 ($p < 0.001$) and 240 mins ($p < 0.05$).

3.4. SERIES III: SR TUBING VS SERIES II: SFSR TUBING

3.4.1. Introduction

This paragraph gives the results of the experiments with the silicone rubber (SR) tubing system, as compared with the SFSR tubing system (see figure 2.5.2. for the identical circuits for both series). In these circuits the rotor blood pump was employed.

The SFSR tubing group IV with the incorporation of a standard roller pump (3.3.) is therefore different from the SFSR tubing group II described in this paragraph. The differences caused by these two types of pumps will be discussed in the following chapter (paragraph 4.2.).

There was a difference between both series in the priming fluid: the SFSR group was primed with blood, while circuits in the SR group were filled with blood and plasma expander in a 1:1 ratio.

Postoperative complications were not encountered. Both series consisted of six experiments.

3.4. Series III: SR tubing

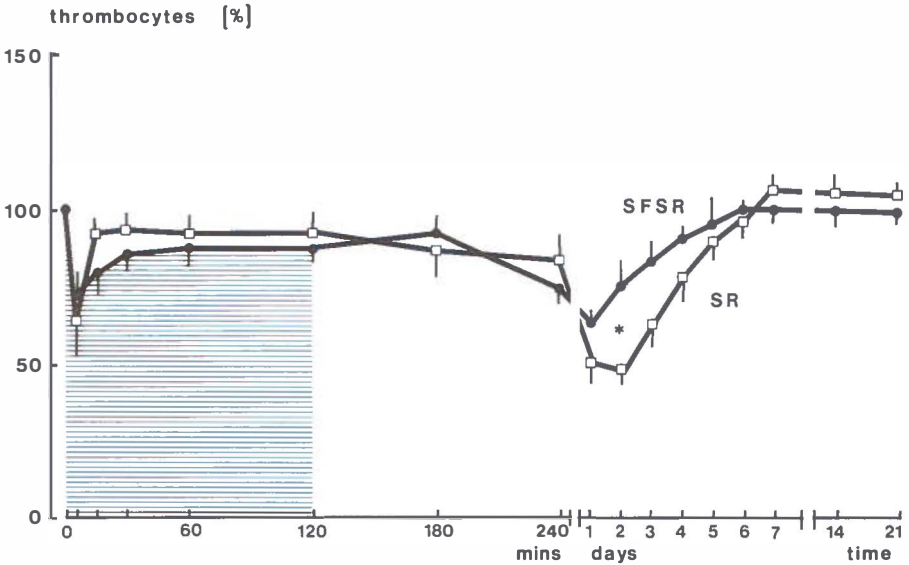

Figure 3.4.2. Percentage of thrombocyte number

In both groups the starting of ECC caused an initial dip to about 70 % of circulating thrombocytes followed by a level of around 90 % and a slight decrease to 80 % two hours after perfusion. The SFSR tubing group showed a secondary dip to 63 % on day one after the experiment, while in the SR tubing group this decrease was extended to 48 % on day two. At this time the difference with the SFSR group of experiments was statistically significant ($p < 0.05$). After these minima in thrombocyte number both groups showed gradual increases towards preoperative percentages on day five.

3.4. Series III: SR tubing

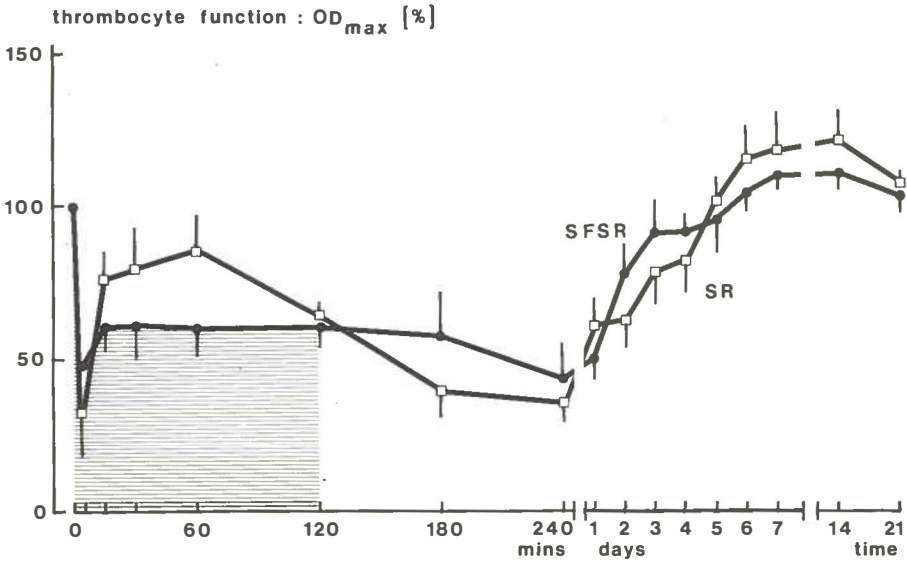

Figure 3.4.3. Percentage of thrombocyte function: OD_{max}

During ECC the SFSR tubing group showed an initial dip to 46 % followed by a stabilized level of 60 % of OD_{max} from 15 mins to the end of the perfusion period. After disconnection the thrombocyte function slightly decreased to 42 % two hours after ECC.

In the SR tubing group there was a somewhat more pronounced initial dip to 32 %, but the function returned to a higher level than in the SFSR tubing group between 30-60 mins of ECC (maximal value: 84 % at 60 mins as compared to 58 %). Subsequently the function decreased to 62 % at the end of the ECC period and to 36 % at the end of the day of the experiment. Recovery of function was already noticed on the first day, which implies that in both groups the secondary dip in function had been reached at the end of the day of the experiment. Normal values were found on day five and a 10-20 % overshoot of function was observed during the second week. No significant differences between both groups were encountered throughout the period of three weeks.

3.4. Series III: SR tubing

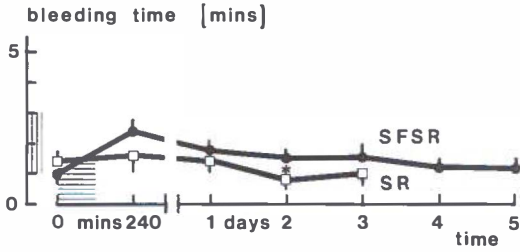

Figure 3.4.4. Bleeding time

In the SR tubing group the bleeding time remained practically unchanged with values between 60 and 90 secs. The SFSR tubing group showed an only slightly increased bleeding time of 2 mins 20 secs at the end of the day of the experiment (normal range: 1-3 mins). The further courses of both groups were identical.

3.4. Series III: SR tubing

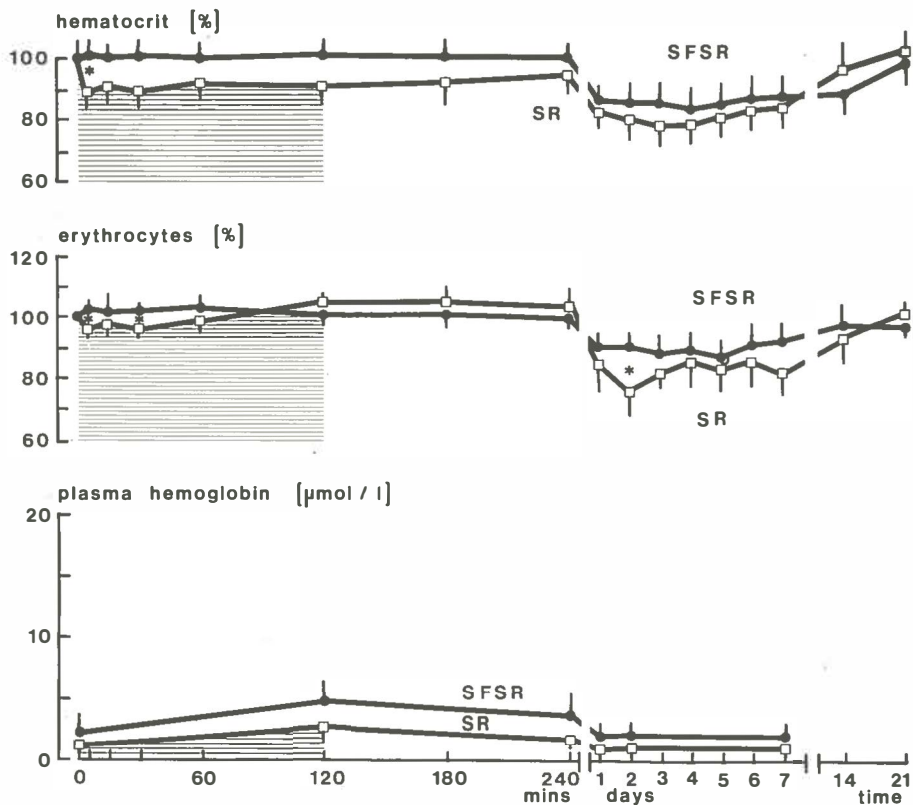

Figure 3.4.5. Percentage of hematocrit and erythrocyte number, and level of plasma hemoglobin

As the SFSR tubing group was primed with autologous blood and the SR tubing group with 1:1 diluted blood, there was a constant difference in hematocrit of about 10 % throughout the day of the experiment, which difference only showed statistical significance after 5 mins ($p < 0.05$). During the days after the experiment both groups showed identical courses of decrease to about 80 %. Preoperative hematocrit values were reached after two weeks.

During the early period of ECC the number of erythrocytes remained unchanged (101 %) in the SFSR tubing series in contrast to 96 % in the SR tubing series. After one hour of ECC in both series the number of erythrocytes was 100 % and this level was unchanged throughout the remaining period of the day. In the group of SFSR tubing there was a slight decrease to about 90 % on the following days, whereas the SR tubing group showed a significantly lower value of 76 % on day two after the experiment. This lower level was maintained for a period of one week.

Normal values were found on day 14 in both groups. Significant differences between both groups were found after five and 30 mins and on day two ($p < 0.05$).

In both groups minimal increases of plasma hemoglobin were found at the end of the ECC procedure, while from day one all values were normal.

3.4. Series III: SR tubing.

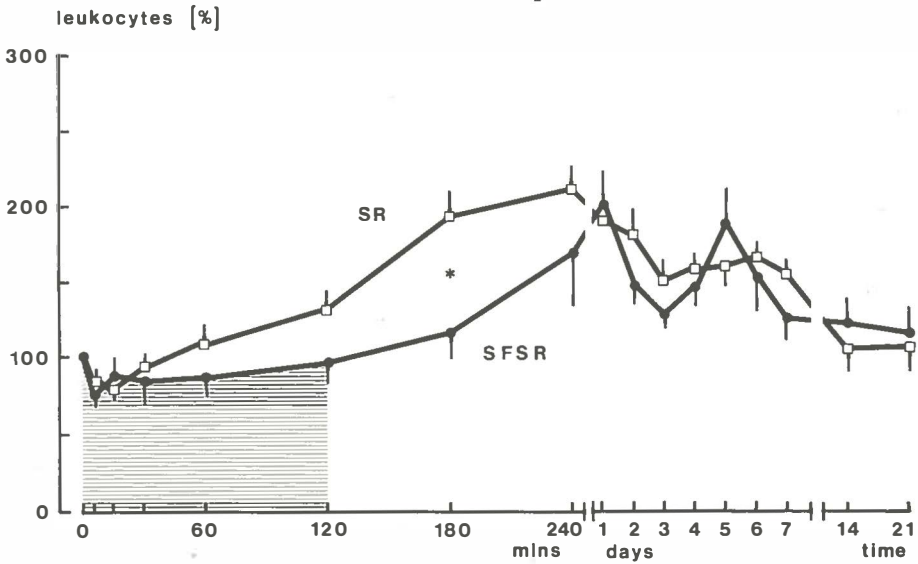

Figure 3.4.6. Percentage of leukocyte number

An initial decrease to about 80 % of circulating leukocytes was measured for both series of experiments. In the SFSR tubing series this dip was followed by a stable level of about 90 % during the remaining period of ECC and after disconnection by a gradual increase to 197 % on day one. For the SR tubing series, however, a continuous increase was observed after the initial dip to a maximum of 209 % after 240 mins. Only after 180 mins the leukocytosis in the latter series was significantly higher ($p < 0.01$). From day one onwards the patterns of leukocyte number were comparable in both series and resembled the curve of the PVC tubing series (figure 3.2.6.).

3.5. DISCUSSION

3.5.1. General reaction

3.5.1.1. Number of thrombocytes

The general reaction of the platelet number when blood is exposed to extracorporeal circulation (ECC) is illustrated by the experiments with the basic ECC system consisting of PVC tubing and a roller pump (series I; figure 3.2.2.). The resulting curve shows:

1. a substantial initial dip of more than 50 % within 5 mins after starting the ECC followed by a recovery to about 90 % over a period of 30 mins.
2. a state of equilibrium at about 90 % during the remaining period of ECC.
3. a postoperative decrease in number with a secondary dip on day one.
4. a restoration to the preperfusion number during days 2-5.

The initial dip in numbers has now been well established for circuits with interconnected oxygenators or dialyzers, both experimentally (de Leval et al., 1972; Mielke et al., 1973; Grabowski et al., 1977., Addonizio et al., 1978; 1981) and clinically (Salzmann, 1971; Moriau et al., 1977). According to Salzmann (1963, 1975) the development of thrombocytopenia is a consistent consequence of EEC in which the principal loss of platelets occurs within moments of the first contact of blood with the prosthetic device. However, the interaction between thrombocytes and mere circuits has only occasionally been described: reports from de Leval et al. (1972, 1975) reveal a 50 % fall of platelet numbers occurring at the initiation of bypass. Our experiments are even more explicit: the number of circulating thrombocytes has decreased substantially as early as one minute after starting the bypass and a minimum level is reached within minutes. This instantaneous and massive disappearance of thrombocytes from the circulation can only be explained by an acute aggregation phenomenon. Although it has been suggested that all platelet losses occur in the EEC (Salzmann, 1963), this appears to be unlikely (de Leval et al., 1972; 1975; Mielke et al., 1973), or only part of the explanation (Hope et al., 1981). The phenomenon takes place within one minute (de Jong et al., 1977), during which only a part of the total blood volume has passed the circuit. It is more probable that at the very first contact with the nonphysiological ECC blood cells (thrombocytes, erythrocytes) are damaged (Parker-Williams, 1972) and release their constituents, of which ADP is the most important. Released ADP can provoke manifold reactions: it is a chemotactic factor for polymorphonuclear (PMN) leukocytes and

it induces aggregation and adhesion of leukocytes and thrombocytes (McIntire et al., 1980).

Each human erythrocyte contains 10^8 molecules of ATP and about 10^7 molecules of ADP. If the cell is disrupted these molecules are released and the ATP is converted rapidly to ADP by various extracellular enzyme systems, yielding up to 10^{15} molecules of ADP per erythrocyte (Williams, 1980). This quantity of ADP is large compared with the amounts liberated by platelets when they undergo the release reaction.

Minor damage to the erythrocytes liberates enough ADP to provoke adhesion between thrombocytes and the circuit material (Schmid-Schönbein et al., 1979). The adherent platelets then undergo a shape change (refractory state, hypercoagulable state) which is associated with the release of bioamines like ADP from the platelets (Leonard, 1969; Born, 1976; Frojmovic, 1978; Ramstack et al, 1979). By this release the surrounding platelets are, in turn, rendered sticky and, together with calcium ions and fibrinogen as cofactors provided by the plasma, aggregates develop by the formation of calcium bridges between sialic acid residues on fibrinogen and similar acidic groups on the platelet surface (Kim et al., 1974, 1977).

	threshold shear stress (N/m ²)	reference	species
thrombocytes	10	Brown et al., 1975	human
	30	Ramstack et al., 1979	canine
	50	Schmid-Schönbein, 1981	human
leukocytes	10	McIntire et al., 1980	human
erythrocytes	150	Leverett et al., 1972	human
	150	Hellums et al., 1977	human
	150	Olijslager, 1982	canine

Table 3.5.1.1.1. Threshold shear stress for release reaction

Not only do nonphysiological surfaces provoke aggregation, but shear (or pump) induced damage to thrombocytes, leukocytes and erythrocytes (table 3.5.1.1.1.) also results in the release of bioamines and other active substances and, as a consequence, induces aggregation of surrounding leukocytes and thrombocytes (Anderson et al., 1978; McIntire et al., 1980). Evidence for this hypothesis was, among others, brought about by experiments in which Robin-

son et al. (1978) infused ECC treated blood or PRP in dogs and by doing so produced an immediate and marked drop in the number of circulating platelets. They concluded that ECC induced thrombocytopenia was the result of stressing a few blood cells which in turn affects the general platelet population within the animal. Murphy et al. (1971) and Swedenburg et al. (1971) were able to show that ADP is one of the bioamines capable of causing intravascular aggregation: by injecting physiological amounts of ADP in dogs they provoked a decrease in platelet count towards 70 % of the baseline value and showed that ADP from damaged platelets is a factor that induces intravascular aggregation. During bypass procedures elevated levels of several aggregation inducing agents have been reported: ADP (Bernstein et al., 1974; Born, 1979; Kalter et al., 1979, Hardwick et al., 1983), serotonin (Swank et al., 1964; Iliçin et al., 1972; Lindsay et al., 1977), thromboxane A2 (Salzmann et al., 1978) and B2 (Addonizio et al., 1980), and thrombin (Born, 1976). Other factors may also be involved, since a correlation between in vivo thrombocyte loss and complement activation has been established (Hakim et al., 1979). It is of interest to note that Robinson et al. (1978) in their experiments with infusion of ECC treated blood did not measure thrombocytopenic responses from pumpless circuits, which implied that the reaction in the recipient animal had to be attributed to pump induced stress rather than to surface contact of the blood with the materials of the ECC. In our laboratory we have tried to repeat these experiments in dogs. After connecting the outflow side of a pumpless extracorporeal system to a blood bag, 400 ml of blood was collected by gravity in CDP anticoagulant solution with simultaneous infusion of the same quantity of saline. In the animal no changes in platelet numbers, corrected for hemodilution, occurred during this procedure. However, platelet numbers of the drained blood in the collection bag were sharply decreased. When the content of the blood bag with decreased thrombocyte numbers was reinfused in the dog, an immediate drop to 20 % of the preinfusion value was measured. This simple experiment clearly indicates that interaction between the blood cells and the surface of the collection bag does result in the release of agents that cause acute aggregation after reinfusion. These findings that differ from those of Robinson are further supported by reports about the demonstration of platelet aggregates in blood bags (Solis et al., 1974) and extracorporeal circuits (Dutton et al., 1974; Reed et al., 1974; Weston et al., 1979) alike.

In the procedure of extracorporeal circulation

other factors are involved that may cause or aggravate the initial dip. Among others there are reports of the thrombocyte depressing influence of priming fluids (Hey, 1976; Woltjes et al., 1979), anesthesia (Kennedy et al., 1978; van Hoof et al., 1980; Zahavi et al., 1980) and heparinization (Eika, 1972; Solis et al., 1975; Bell et al., 1976; Lindsay, 1976; Wurzinger et al., 1979). Some investigators deny any influence of heparin on thrombocytes (Friedman et al., 1970; de Leval et al., 1972; Heiden et al., 1977; Robinson et al., 1978). In man heparin is thought to exert an aggregating effect on platelets by inducing the release of intraplatelet ADP by a direct effect on the platelet membrane (Eika, 1972). This author suggested that heparin induces release of ADP especially in young and functionally active cells, bringing these thrombocytes in a refractory state. As this relationship of the interaction between heparin and human platelets is dose dependent (Mustard et al., 1965; Rowsell et al., 1967), careful monitoring of the heparin regime, which can be performed by means of the Activated Clotting Time (ACT), advances minimal heparin administration and consequently minimal effect on platelets. In our canine experiments, however, neither anesthesia nor heparin had any influence on platelet numbers, as shown by standard comparison of the preoperative I and preoperative II samples.

Other possible hematological complications of the ECC procedure concern the administration of various non blood fluids to prime the circuit. In this regard plasma expanders have a specific influence (Silvay et al., 1968; Wellmer, 1968; Hey, 1976). Woltjes et al. (1979) have concluded from canine experiments that some priming solutions, such as dextran solution or gelatin solution, exert an apparent aggregating effect. Since we used gelatin solution to prime the extracorporeal circuits, the initial decrease in thrombocyte numbers can - at least partly - be attributed to the application of gelatin priming solutions.

The group of De Leval, Heiden and Mielke has postulated three different basic types of platelet damage which result in reduced numbers:

1. adhesion of thrombocytes to nonphysiological surfaces in the extracorporeal circuit (de Leval et al., 1972)
2. reversibly aggregation, after which platelets, temporarily trapped in the liver, dissociate and return into the circulation (de Leval et al., 1972, 1975; Heiden et al., 1975; Hope et al., 1981)
3. irreversible damage, after which aggregates and fragments are permanently trapped in the liver and eventually eliminated by the spleen (Lötter et

al., 1980) and the reticulo-endothelial system (Heiden et al., 1975).

In kinetic studies with ^{51}Cr labelled platelets (de Leval et al., 1972) or ^{111}In labelled platelets (Hope et al., 1981) it was shown that platelets that are removed from the circulation during the early minutes of ECC follow the second of these basic types: trapping is concentrated in the liver. Another important observation was that the loss from and the return into the circulation on the one hand and the changes in radioactivity on the other hand are closely related. This implies that the initial dip in thrombocyte count does not involve a permanent loss, but a reversible process of temporarily trapped platelet aggregates. The curves from our experiments confirm these results by showing invariably that initial decreases are followed by restorations of numbers.

Figure 3.2.2. shows that after the relatively slow disaggregation of the initially formed aggregates a stable level of 88 % thrombocytes is reached. The stability points to a dynamic state of equilibrium between continuous aggregation and subsequent disaggregation of the thrombocytes. That stable level can possibly be regarded as a measure for the hemocompatibility of the extracorporeal circuit involved (de Jong et al., 1977). Under experimental conditions such stabilized platelet levels during ECC have also been measured by Mielke et al. (1973). The period during which the state of equilibrium can be maintained appears not to be limited to the two hours of this protocol (Leichtman et al., 1977). Extension of the ECC period to four hours, performed in four separate experiments, has revealed that for both periods alike stable levels are maintained until the moment of disconnection of the circuit. Reports of still longer periods of perfusion indicate that ultimately exhaustion and elimination of the thrombocytes may occur as a consequence of continuous aggregation and disaggregation processes (Bloom et al., 1974).

After disconnection of the ECC the equilibrium is disturbed: stimulation of thrombocyte aggregation has come to an end while disaggregation and consequent release from the liver still continues. This results in a slight increase in thrombocyte numbers shortly after disconnection of the circuit, a phenomenon also observed after clinical perfusions (Hill et al., 1972; McKenna et al., 1975) and after in vitro extracorporeal circulation of human blood (Addonizio et al., 1978). The small increase in numbers appears to be temporary: from one hour after ECC onwards a decrease in numbers is observed and after 24 hours a distinctive secondary dip is measured. Such a se-

condary dip can be explained by the early elimination of irreversibly damaged thrombocytes from the circulation (Salzmann, 1971). All thrombocytes rendered non-functional by the ECC procedure have been removed from the circulation. Therefore the remaining percentage, which consists of all still viable cells, can be considered as an indication of the hemocompatibility of the ECC system involved. However, early elimination is not the only reason for decreased thrombocyte numbers shortly after disconnection of the ECC. Protamine chloride, administered to neutralize heparin, possesses an important side effect: as a cationic polymer it can induce aggregation of thrombocytes by direct binding to the negative surface charge of the platelet membrane. As a result bridges are formed between adjacent platelets (Eika, 1972) and both thrombocyte numbers and function will be depressed (Woods et al., 1967; Goldman et al., 1969; Fleming et al., 1977; Moriau et al., 1977; Velders et al., 1979; Wenzel et al., 1979). As protamine is metabolized by first pass effects, its thrombocyte reducing capacity only intervenes with the thrombocyte behaviour during the early recovery period on the day of the experiment.

After the secondary dip the release of new thrombocytes from the bone marrow exceeds the normal elimination of altered thrombocytes. The resulting restoration occurs gradually and the normal preoperative value of thrombocyte numbers is found after five days. For deeper secondary dips the restoration to preoperative numbers can be delayed until day seven, because recovery is determined only by the thrombopoietic capacity of the animal. This also explains the identical and parallel courses of the curves from different experiments.

3.5.1.2. Function of thrombocytes: ODmax

Many investigators have reported depressed thrombocyte function during extracorporeal circulation (Bloom et al., 1974; McKenna et al., 1975; Laufer et al., 1975; Bick et al., 1976; Mielke et al., 1977; Moriau et al., 1977). Thrombocyte function curves are, however, expressed in many different ways, mostly incomparable. The main complication in assessing thrombocyte function is the controversy about the value of the various in vitro tests as indications of the in vivo functional capacity of the thrombocytes (Weiss, 1976). Since platelet function cannot be directly evaluated, it is assessed indirectly by in vitro tests measuring one or more of the various aspects of the process, e.g. platelet adhesiveness (on glass bead filters), aggregation, PF3 availability or clot retraction. The most important of these tests is the technique of platelet aggregation, first described by Born et al. (1963), which

has the advantage that it has been well established and widely used and that it provides reproducible results. On the other hand, the conditions under which the test is performed are necessarily different from the conditions in the animal: even careful handling of the blood specimen may cause changes in function of the platelets; moreover, the nature or the amount of the triggering agent or both are unphysiological. For the ADP induced aggregation the critical concentration of ADP is species dependent (Blakely, 1972; Spurling, 1977): canine platelets are aggregated by concentrations of ADP five times higher than those of human beings. However, adaptations in the test procedure can be performed: in our setup the manipulations to concentrate or to dilute the platelet rich plasma with the aim of equalizing numbers have been avoided by the use of the thrombocyte nomogram. Moreover, in the seventies a system has been introduced for measuring aggregation in native blood instead of plasma by means of measuring the screen filtration pressure (van Kessel, 1977). This further diminishes the manipulation of the blood. Despite the discussions about the value of the in vitro ADP induced platelet aggregation test, it probably provides the best possible approximation of the thrombocyte function at this moment. Further sophistication and standardization in the near future may render it an even more reliable quantitative indicator of platelet function. However, other concepts are also possible: biochemical methods have been developed to measure specific platelet release products as PF₃, PF₄, beta-thromboglobulin, serotonin and thromboxane B₂, which methods might refine the quantitative assessment of platelet damage (Ludlam et al., 1975; Bernstein et al., 1977; Anderson et al., 1978; Kaplan et al., 1981; David et al., 1982); another method, the hypotonic shock response (Hardeman, 1974), measures serotonin uptake.

The thrombocyte function, given in figure 3.2.3., shows a pattern analogous to that of the number of thrombocytes. The initiation of perfusion results in an initial dip with a low OD_{max} similar to the dip in the number of platelets. Addonizio et al. (1978) also observed such an initial dip during experimental ECC in monkeys. These findings are in accordance with the idea that a great part of the active thrombocyte population is involved in the acute aggregation phenomenon. Priming fluids, anesthesia and heparinization may exert depressing influences on thrombocyte function and, actually, such influences have been documented in human conditions (Kalter et al., 1979; Zahavi et al., 1980). Others, however, deny effects of anesthesia (Kennedy et al., 1978; Kalter et al., 1979) and heparin (Kennedy et al., 1978) or

question such effects (Wessler et al., 1976). In our canine experiments we could not establish that either anesthesia or heparin had any influence on thrombocyte function as has been surveyed by standard comparison of the preoperative I and the preoperative II samples. However, plasma expanders did exert an apparent aggregating influence both according to reports from other investigators (Wellmer, 1968; Hey 1976; Woltjes et al., 1979) and in our experiments. Consequently, the use of gelatin solution to prime the extracorporeal circuit implicates that at least part of the noticed initial dip in thrombocyte function is accounted for by the use of gelatin priming solutions. The reversibility of the aggregation process is accentuated by a gradual increase of ODmax from 15 minutes until the end of bypass. The first cells to reappear into the circulation are the most loosely attached thrombocytes in the outer shells of the aggregates, i.e. the older ones. According to Karpatkin (1969), Booyse et al. (1971) and Penington et al. (1976) these older thrombocytes are also relatively small. Laufer et al. (1975) observed that in man 30 % of the platelet population consists of equal amounts of large and small thrombocytes. Ten minutes after initiation of cardiopulmonary bypass the mean platelet volume (MPV) had decreased to 85 % of the control value and after 50 minutes a plateau of 75 % was reached. Two hours after disconnection MPV returned to 97 %. Laufer concluded that, since thrombocyte numbers are markedly decreased during bypass, a simultaneous 25 % decrease in MPV can only be explained by a selective disappearance of the large platelets from the circulation. As the larger platelets are young and functionally more potent than the smaller ones, this may provide an explanation for the observed decrease in platelet function during perfusion.

The restoration of ODmax after the initial dip occurs more slowly than the increase in platelet numbers, but the stable level after the initial dip is in accordance with the curve of thrombocyte numbers. After the disconnection of the ECC the recirculation of disaggregated thrombocytes and the administration of protamine chloride clearly result in a lower ODmax. When the secondary dip in thrombocyte numbers occurs, all cells that have been damaged by consecutive aggregation and disaggregation processes are eliminated. Concomitantly the remaining thrombocytes show a decreased function. Thereafter the function is restored parallel with the formation of new thrombocytes.

3.5.1.3. Bleeding time

The bleeding time is affected by the combination of changes in thrombocyte numbers and function (Harker

et al., 1972; Silvergleid, 1980; Slichter, 1982) and is relatively independent of fibrin formation (Borchgrevink et al., 1961; Ludlam, 1971; Heiden et al., 1977). Consequently the bleeding time is of great practical relevance as an overall measurement of hemostasis (Hathaway, 1971; Harker et al., 1972; Levine, 1975), although the parameter is neither very accurate nor very sensitive. In spite of this the results of the bleeding time measurements in our experiments are largely consistent with the thrombocyte behaviour in all experimental groups. In the experiments with the PVC circuit a bleeding time of about 4 minutes was measured at the end of the day of the experiment. This means that in clinical terms a loss of 15 % in thrombocyte numbers and 60 % in thrombocyte function results in a significant increase in the bleeding time from 1 to 4 minutes (normal range 1-3 minutes). The introduction of young and viable platelets into the circulation assures the normalization of the bleeding time (2 minutes) on the following day. In this series the slightly increased bleeding time can only be demonstrated during the day of the experiment.

3.5.1.4. Hemoglobin, hematocrit, number of erythrocytes, and plasma hemoglobin

It has been known for a long time that destruction of erythrocytes is a common complication during extracorporeal circulation. Traditionally the level of plasma hemoglobin has been used as the quantitative indication of the hemolysis with heart-lung machines (Liddicoat et al., 1975; Clark et al., 1979), hemodialyzers (Hyde et al., 1969) or even artificial heart valves (Roschke et al., 1977). In the ECC induced red cell destruction does not only the adhesion of blood onto nonphysiological surfaces play its role, but also fluid mechanical effects such as elevated shear stresses are directly involved. Damage to sheared erythrocytes is normally explained in terms of cell membrane damage resulting in increased membrane porosity and augmented influx or reflux of water, ions and other cell constituents such as ADP and serotonin (Bernstein et al., 1967; Lubowitz et al., 1974; Birnbaum et al., 1977). This kind of cell wall damage with its consequent volume changes is reversible unless the trauma inflicted is so severe that it impedes regaining of the proper membrane function (Birnbaum et al., 1977). When shear stresses higher than the threshold level of 150 N/m^2 (Brown et al., 1975) are applied to erythrocytes, the cells are hemolyzed. Repetitive contact with high shear stresses has a lowering effect on the critical shear stresses at which erythrocytes rupture (Leverett et al., 1972).

Fluid mechanical estimations have shown that in

e.g. roller pumps under severe pressure conditions laminar shear stresses in the order of 1000-3000 N/m² (Lambert, 1979) are reached. These are sufficiently high for the given exposure times in roller pumps to cause liberation of ADP and serotonin and to induce a detectable raise in plasma hemoglobin (Hellums et al., 1977). But even when erythrocytes are not ruptured by a single passage through a very high shear stress region, they are abnormal. The work of the group from Rice University (Velker et al., 1977; O'Rear et al., 1979) has shown that cells subjected to sublethal shear stresses seem to be normal biconcave discs, but have become much more rigid (or less flexible), while the mean erythrocyte volume may increase with about 10 % (Birnbaum et al., 1979; Williams et al., 1980). Such a mechanical trauma may lead to accelerated ageing (Williams, 1971) and to enhanced sequestration of those cells (Sandza et al., 1974). Tabak et al. (1981) measured the erythrocytes survival (half-life) after ECC in dogs and found a significant shortening in half-life. In their opinion such a profound erythrocyte injury can be clinically manifested by postoperative anemia. Sublethal damage therefore does not necessarily raise plasma hemoglobin concentration but can be held responsible for anemia during the postoperative period. For this reason the measure of plasma hemoglobin is not an adequate indicator of ECC induced erythrocyte damage (Kusserow et al., 1966). As both irreversible and sublethal erythrocyte damage result in the liberation of platelet aggregation promoting factors such as ADP and serotonin, injury of red cells should not only be regarded as a threat to the erythrocytes and oxygen transport, but also as an important triggering factor in all hemostatic reactions involving thrombocytes (Schmid-Schönbein et al., 1979). This conclusion is of special relevance for the initial dip of thrombocyte numbers and function (see 3.5.1.1. and 3.5.1.2.). The amount of bioamine needed for inducing the observed massive platelet aggregation can only be provided by erythrocytes, since these are present in the blood in far greater numbers than platelets. Therefore the use of drugs to reduce the initial dip of platelets should be directed to the protection of the erythrocytes.

During the day of the experiment no changes are measured in the number of erythrocytes, corrected for hemodilution. Calculation reveals that the changes in the curves of hematocrit and hemoglobin are direct reflections of the mixing of priming fluid with the blood of the animal. Hemodilution is followed by the progressive elimination of the gelatin solution which has a half life of about 4-5 hours (Silvay et al, 1968; Hammer, 1976). It can therefore readily be

assumed that nearby all gelatin has been eliminated on the day after the experiment and for this reason correction for hemodilution has not been applied from day one onwards. The increase in plasma hemoglobin after two hours of ECC proves that a number of erythrocytes has undergone hemolysis. It is beyond doubt that the two roller pumps of the ECC must be held responsible for the high shear stresses (1000-3000 N/m²; Lambert, 1979) rupturing part of the red cells. Assuming that the average hemoglobin concentration of a dog is 10.7 mmol/l (see 2.7.8.), it can be calculated that the rise of 10.2 μ mol/l in plasma hemoglobin concentration at the end of the perfusion period has been caused by the hemolysis of about 0.1 % of the circulating erythrocytes. After disconnection of the circuit the parameter of plasma hemoglobin is no longer an exact measure for the degree of hemolysis because free hemoglobin is bound as dissociated dimers to haptoglobin (Hershko et al., 1972; Spurling, 1977; van Gool, 1980) or as oxidized heme groups to hemopexin (Muller-Eberhard, 1970; van Gool, 1980), or eliminated by renal filtration. Preoperative concentrations are regained within two days.

After the operation a decreased level of about 70 %, lasting for a period of a week has been measured for erythrocyte numbers, hematocrit and hemoglobin. Considering the above conclusion that only 0.1 % of the red cells has undergone hemolysis during the ECC procedure, it must be assumed that an important percentage of the red cell mass has been sublethally damaged by the high shear stresses inflicted by the material and the roller pumps. This mechanical trauma leads to accelerated ageing and enhanced sequestration of the affected erythrocytes (Indeglia et al., 1968; Williams, 1980). Preoperative levels are restored in close connection with the formation of new erythrocytes during the following weeks.

Hemodilution and blood loss caused by sampling during the day of the experiment do not contribute to the decreased values during the days after the experiment, since these losses have been calculated and taken into account with the returning of blood from the circuit to the animal.

3.5.1.5. Number of leukocytes

Granulocytes which form about 67 % of all leukocytes in dogs (Spurling, 1977) are potent cells for aspecific defense (Hakim et al., 1979). They exert their bactericidal functions through mobilization and ingestion followed by intraleukocytic killing of bacteria. In contact with extracorporeal circuits granulocytes are easily damaged, since they are of at least the same fragility as thrombocytes and probably more susceptible than erythrocytes (Dewitz et al., 1979; McIntire et al., 1981). Mechanical stress or

chemical damage of leukocytes leads to increased adhesion and release of inflammatory and cytotoxic agents (Dewitz et al., 1977, 1978). Evidently the leukocytes are the primary mediators of lung damage and microaggregate formation following ECC procedures (Jacob et al., 1980). Several mechanisms of this leukocyte dysfunction have been proposed, including plasma mediated complement activation (Hakim et al., 1980; Wilson et al., 1980), cell mediated release of chemotactic and inflammatory factors (Graham, 1975), and direct damage to the leukocytes by high shear stresses. McIntire and his group have established (McIntire et al., 1980) that high shear stresses are indeed a possible source of the impaired leukocyte function observed after ECC, the trauma being independent of complement activation. However, activation of complement factors, which basically is a disturbance in the plasma proteins, is capable of inducing leukocyte aggregation (Hakim et al., 1980; McIntire et al., 1980). In this respect complement factors C3a and C5a are of special importance (Jacob et al., 1980; Hammerschmidt et al., 1981). The following sequence is initiated: leukocyte aggregates plug the capillaries, the release of proteolytic enzymes and oxygen radicals damages the vascular endothelium, and lung edema develops (Hammerschmidt et al., 1979; Wildevuur, 1980). The endothelial damage also activates platelets with the consequence that thrombocyte aggregates are formed (Wonders et al., 1983). All these factors lead to disturbed microcirculation (Pranger et al., 1980) of which respiratory insufficiency and disturbed peripheral circulation are possible consequences (Hammerschmidt et al., 1979; 1980; McIntire et al., 1980; Jacob et al., 1980).

Another aspect of leukocyte damage is that the defense mechanism against infection is affected. High incidences of infection have been reported after ECC (Goodman et al., 1968; Blakemore et al., 1971; Hakim et al., 1979). Dankert et al. (1978) reported that in a clinical study of 700 patients undergoing open heart surgery about 20 % developed infection after the operation despite prophylactic antibiotic treatment. The same study has shown that 80 % of the extracorporeal circuits, expected to remain sterile throughout the operation, in fact became contaminated. This was substantiated in an experimental study in our laboratory in which four dogs out of 13 undergoing autotransfusion had positive blood cultures of exogenous origin. Several of these dogs died of septicemia (Zijlstra et al., 1978). This evidence points to the importance of establishing a leukocyte function test to measure leukocyte impairment quantitatively. In our laboratory such a test, based on the phagocytic capacity of leukocytes, specifically

neutrophils, has been developed. In this quick and easy test carbonylated iron particles are phagocytized (Woltjes et al., 1976). Results obtained with this test show that leukocyte function progressively decreases during ECC: after two hours of perfusion with a circuit without oxygenator phagocytosis is decreased to 50 % of the preperfusion value (de Jong et al., 1977).

Phagocytosis can also be impaired experimentally by autotransfusion (Woltjes et al., 1976; Zijlstra et al., 1978), and clinically by extracorporeal perfusion (Deggeler et al., 1979) and by hemodialysis (Lindsay et al., 1980). Impaired phagocytosis may promote sepsis (Drinker, 1972).

During the period of ECC the basic pattern of changes in leukocyte numbers has an analogue in the changes in thrombocyte numbers (figure 3.2.2.). The curve of the general, aspecific (Veenhof, 1976; Hakim et al., 1979), reaction to the PVC circuit with roller pump (figure 3.2.6.) shows:

1. a substantial initial dip in numbers of about 60 % within five minutes after starting the ECC, followed by a recovery to normal values over a period of 30 mins
2. a state of equilibrium at 100 % during the remaining period of ECC
3. a gradual postoperative increase in numbers with two "camel-humps" of roughly 200 % on days one and six.
4. a decrease to preoperative numbers during the second week.

In 1966 Machanic (reviewed by Kusserow et al., 1971) showed that this sequence of leukopenia and leukocytosis was indeed ECC induced, excluding traumatizing factors as e.g. surgery, cannulation, anticoagulation, and anesthesia.

The initial dip in leukocyte numbers has been described before (Galletti, 1971; Brubaker et al., 1972; McIntire et al., 1976; Veenhof, 1976). According to Kaplow (1968), Galletti (1971) and Henderson et al. (1975) blood exposed to prosthetic devices initially exhibits a rapid, often dramatic leukopenia at the expense of mature forms of granulocytes. Induction of complement activation and aggregation of leukocytes are held responsible for the initial dip in leukocyte numbers (Craddock et al., 1977; Jacob et al., 1980). Therefore the initial dip is not provoked by shear stress alone, but is even mainly dependent on the properties of the blood contacting materials (Kusserow et al., 1971).

In a clinical study with kidney dialyzers Brubaker et al. (1971) observed a pronounced fall of the monocyte count to nearly zero. They did not find a consistent increase of monocyte count to over baseline

values during the rebound phase, in contrast to the neutrophil count. Lymphocyte counts showed no significant changes during hemodialysis, but the observed variability of these counts was relatively greater than those of neutrophils or monocytes. The neutrophil count fell to nearly zero shortly after the onset of dialysis, which implies that the majority of circulating white cells were lymphocytes. Results from other workers (Goodman et al., 1968; Kusserow et al., 1968; 1969; Craddock et al., 1977) and from our laboratory (Wildevuur-van Hamersveld et al., 1976) are generally in agreement with these data. In an experimental study with oxygenators and dialyzers we observed that primarily the neutrophilic granulocytes were affected. Within five minutes of ECC the morphology of many granulocytes was altered: the shape was mostly elongated and irregular, the nucleus frequently folded and younger neutrophilic granulocytes appeared. An abnormal aspect of the lymphocytes was frequently observed during ECC and around the third day after ECC many of the mononuclear cells had the appearance of plasma cells.

Changes in the number of lymphocytes were observed on the first and second day after CPB. Depressed cell mediated immunity following CPB (Roth et al., 1981) is most likely due to a decreased number of T-helper cells (Murawska et al, to be published), which the authors ascribe to the effect of anesthetic or bioactive agents, to migration into damaged tissue, or to monocyte activity.

Formed leukocyte aggregates are probably temporarily trapped in the lungs and returned into the circulation after disaggregation. Traumatized leukocytes may also adhere to the endothelium of organs and the vasculature until recovery from the trauma occurs. Then the cells detach themselves and reenter the circulation (McIntire et al., 1980). However, in comparison with the behaviour of the thrombocytes, the initial dip of the leukocytes is more quickly reserved by the release of immature leukocytes from the marginated pool and the bone marrow reserve into the circulation, which compensates for the momentary massive disappearance from the circulation (Kaplow, 1968; Brubaker et al., 1971; 1972; Spurling, 1977). As a consequence even leukocytosis is observed after the operation (and often already during perfusion) both in clinical and experimental circumstances (Kaplow, 1968; Kusserow et al., 1971, 1975; McIntire et al., 1976; Paping et al., 1978). The extent of the increase in leukocyte numbers is mainly determined by the degree of shear stress in the extracorporeal circuit and not by the material induced complement activation (McIntire et al., 1980), which is in contrast to the phenomenon of the initial dip in leukocyte num-

bers that is mainly material dependent. After the initial leukocytosis, when the margined pool is exhausted and suppletion for the further elimination of leukocytes fails, a second leukocytosis peak (second "camel-hump") is measured on day six. This peak can probably be accounted for as a response of the bone marrow to stimulating agents released during the perfusion (Brubaker et al., 1971). This time sequence is in agreement with reports from Spurling (1977) who stated that in normal dogs two thirds of the neutrophils (with a half-life of average 6.7 hours) are in the circulation pool and one third margined in the microvasculature. The neutrophil storage pool in the bone marrow was found to be about 7.5 times greater than in the blood compartment, representing three to four days supply of neutrophils.

3.5.1.6. Sedimentation rate of the erythrocytes

Figure 3.2.7., which gives the changes in SRE following extracorporeal circulation with the PVC circuit, shows that the SRE is moderately elevated after starting ECC and that a stable level of 25-30 mm in one hour is maintained for a period of at least one week. Such an elevation which is also not uncommon after surgery or during infection can coincide with elevated leukocyte numbers. The SRE may sometimes take weeks to return to normal (Spurling, 1977; Loeliger et al., 1977) despite satisfactory clinical recovery. Other factors having an effect on the SRE are several priming solutions such as gelatin (Eichler et al., 1969), agglomerates of blood cells like erythrocyte rouleaux, thrombocyte and leukocyte aggregates, increased concentrations of "acute reacting proteins" such as fibrinogen and haptoglobin, and several immunoglobulins of which IgM is the most prominent (Loeliger et al., 1977). Finally a decreased number of circulating erythrocytes (anemia) can promote rouleaux formation and thus increase the SRE.

As far as the experiments with the PVC circuit are concerned, the elevations of SRE during the day of the experiment must be attributed to surgery, priming fluid and blood cell aggregates, while anemia (figure 3.2.5.) and increased fibrinogen concentrations (figure 3.2.8.) are prominent factors during the period after the experiment. Since the factors of surgery, aggregate formation and priming fluid exert a moderate elevating effect on the SRE in all the eleven series of experiments, the main importance of this parameter is the possibility of using it as one of the indications for infection after the operation. For this reason the SRE has been measured as a routine in all series of experiments according to the protocol, but the results will be omitted in the

following chapters.

3.5.1.7 Body temperature

The slight increases in body temperature (figure 3.2.7.) of maximal 0.5 °C that were measured during the days following ECC represent the normal reaction of the animal after surgery. An increased body temperature provides a possible means for recognizing infection just as the SRE does. In a previous study from our laboratory it was observed that abnormal increases in body temperature coincided with more than moderate elevations in SRE, significant decreases in the leukocyte function and increases in leukocyte numbers (de Jong et al., 1977). In this study one group of dogs had body temperatures of over 39 °C after extracorporeal circulation with an oxygenator and all dogs suffered from bacteriologically confirmed septicemia. On the other hand no infection was found and SRE was only moderately increased in the group with temperatures below 39 °C. However, these results are partly in contradiction with reports from Bell et al. (1978), who were unable to distinguish cardiac valve surgery patients with infection from those without infection in a clinical study using maximal body temperature, mean body temperature and number of leukocytes as parameters. However, tests of leukocyte function were not included in their study.

The results of the body temperature measurements will not be mentioned in the following chapters, because in none of the experimental series have different courses been observed.

3.5.1.8. Fibrinogen, APTT, PTT, RT, and TT

In most respects the blood coagulation system of the dog is comparable with that of man. The main difference between canine and human blood is found in the relatively high activity of the canine coagulation mechanism. Although fibrinogen (factor I) levels are generally equal in dogs and men, the intrinsic and extrinsic pathways of coagulation are much more active in dogs (Spurling, 1977). Evidence of these higher activities was produced by among others Ur (1974), who used impedance coagulography, and by Hawkey (1974), who measured higher levels of activity for factors XII, XI, X, IX, VIII, X, V and II in dogs than in man. As a consequence canine coagulation screening tests have shorter normal values (see table 2.7.7.).

Reports about the response of the fibrinogen concentration to extracorporeal circulation in man describe declines during the period of ECC (Blombäck et al., 1964; Gralnick et al., 1971; Bick et al., 1976; Kalter et al., 1979), probably due to increased shear stresses (Charm et al., 1970). Since most authors have not corrected for hemodilution,

these reports are not necessarily in contradiction with the almost stable levels established in our experiments. General agreement exists about marked decreases of factor V and enhanced fibrinolysis during this period (Bachman et al., 1975; Bick et al., 1976; Kalter et al., 1979). The latter phenomenon results in increased concentrations of fibrin(ogen) degradation products which in turn may cause additional lengthening of the screening coagulation tests. Such lengthening, due to both factor V deficiency and fibrin(ogen) degradation products, was also observed in our experiments with the PVC circuit (figure 3.2.9.): at the end of the ECC period PTT and RT showed lengthened values (TT and APTT were predictably influenced by heparin). At the end of the day of the experiment all four screening tests had slightly shortened clotting times as a reflection of the activated coagulation system and one week later normalization was established.

During the period after the operation the fibrinogen levels increased progressively reaching their maximal value on the second or third day (see also figure 7.4.1.). Reports of other investigators are in agreement with this (Blombäck et al., 1964; Egan et al., 1974). Thereafter this maximal hyperfibrinogenemia gradually declined.

From these results it can be concluded that ECC induced changes in the coagulation system are characterized by hyperfibrinogenemia, activation of the fibrinolytic system and depletion of coagulation factors, specifically factor V. The results of the bleeding time tests also make it clear that fibrin formation only plays a small additional role in the process of ECC induced hemostatic disturbances.

3.5.2. Comparative analysis

Thrombocyte numbers - When silicone rubber (SR) and silica free silicone rubber (SFSR) materials are compared with the previously described PVC tubing (figures 3.3.2. and 3.4.2.), the most striking differences in the number of circulating thrombocytes are the smaller initial dip with the SFSR tubing and the significantly less pronounced secondary dip in the curve of the SFSR tubing as compared to SR material. The difference in the initial dip cannot be interpreted because the priming fluid of the SFSR series did not include gelatin solution in contrast to the other series. It has been shown before that the presence of gelatin exerts an influence on the initial dip (see 3.5.1.1.). The less profound secondary dip for the SFSR tubing is the expression of a smaller amount of eliminated thrombocytes, irreversibly damaged by the ECC proce-

dure.

Thrombocyte function - Comparison of the curves of thrombocyte function shows a significantly higher pattern for the SFSR than for the PVC material during the whole ECC period, whereas important differences were not noticed between SFSR and SR tubing. The measured differences in ODmax were not found after ECC indicating that the higher degree of damage to thrombocyte function in the PVC curve during ECC must be regarded as reversible damage. At the end of the day of the experiment all groups had equal values of ODmax.

Bleeding time - The only substantial platelet difference, a less profound secondary dip in thrombocyte number with the SFSR tubing material, has no significant impact on the clinically relevant parameter of the bleeding time since the critical value of $82 \times 10^9/l$ is not reached.

These observations lead to the conclusion that, as far as thrombocytes are concerned, SFSR tubing should be preferred to SR tubing and both to PVC tubing.

Other investigators agree with this conclusion and have reported improved hemocompatibility of SFSR material compared with SR material (Zapol et al., 1975; Lagergren, 1976; Kolobow et al., 1977; 1978; Chawla et al., 1978; 1979). A contradictory report from Yates et al. (1978), in which no differences were established between SFSR and SR materials, is not convincing since their groups of experiments were too small to draw conclusions. In his recently published thesis Olijslager (1982) has described a test system in dogs, which was used to compare the blood compatibility of SR and PVC tubing materials. After two hours of extracorporeal circulation of heparinized blood SR tubing showed single blood platelets adhering to the surface, whereas the surface of the PVC material was covered with platelet masses with a thickness of one cell layer. The conclusion of this author was that SR does not activate platelets as much as PVC does.

Hematocrit, erythrocyte numbers and plasma hemoglobin - No changes have been observed in the erythrocyte counts of any of the three groups during perfusion, but severe drops appeared in the first days after the experiment, demonstrating early elimination of injured erythrocytes. Although differences were not significant, the consistently higher numbers of erythrocytes in the SFSR group as compared with the PVC group are substantiated by the significantly lower levels of plasma hemoglobin, indicating less erythrocyte damage in the SFSR tubing group. An unexpected observation was the initial, reversible, decrease in the number of circulating erythrocytes in the SR material series, the difference with the SFSR

series being statistically significant at five minutes. During the first days after the experiment an analogous difference was encountered between SFSR and SR materials. It must therefore be concluded that the initial, obviously mostly sublethal, damage is responsible for the temporarily more pronounced anemia in the SR group. The less injurious properties of the SFSR may be related to the fact that the material does not contain additives like peroxide, which are otherwise added for crosslinking (Stevenson et al., 1977). On the other hand, the leaking of chemicals such as plasticisers from PVC tubing into the blood also adds in some degree to the increased hemolysis measured in the PVC circuit (Wielogorski et al., 1976). As far as erythrocyte behaviour is concerned, SFSR must be considered the better hemocompatible material.

Leukocyte numbers - Limited information is available about the interaction between leukocytes and different foreign surfaces. Chawla (1978) showed experimentally that SFSR is better than SR material as far as leukocyte to foreign surface interaction is concerned. This conclusion was based on his observation that SFSR material that had been in contact with canine blood in a test cell under well defined conditions did not show any adhered leukocytes, whereas some adhered cells were seen on the SR material. Chawla also noticed signs of degeneration in these adherent leukocytes. In 3.5.1.5. we reported that the initial dip in leukocyte numbers is mainly material dependent. This dependence is reflected in a much deeper initial dip in leukocyte numbers in the PVC experiments than in the other groups. The differences in the courses during the rest of the day of the experiment cannot easily be accounted for. Differences in adherence of leukocytes to foreign materials may be involved (Chawla, 1978). Despite differences in leukocyte numbers during the day of the experiment, after the operation the series show equal patterns and numbers indicating a comparable degree of leukocompatibility for the three materials.

3.6. CONCLUSIONS

To demonstrate the general behaviour of blood when exposed to an ECC a detailed description is given of the changes caused by a relatively simple extracorporeal circuit consisting of PVC tubing and a roller pump. This basic extracorporeal circuit does not provide spectacular damaging effects. Yet, the circuit contributes to the overall damage caused by the heart-lung machine. Therefore it is of importance to incorporate the least traumatic tubing and blood pump available. Comparison of several tubing systems

under standardized conditions has revealed that silica free silicone rubber (SFSR material) is to be preferred to silica filled silicone rubber (SR) or PVC since:

1. concerning thrombocytes: SFSR gives better results than SR in preserving both numbers and function and both materials are superior to PVC
2. concerning erythrocytes: SFSR has more favourable characteristics than SR and PVC materials
3. concerning leukocytes: SFSR and SR are more compatible than PVC.

In further developments more improvements in tubing materials are likely. Production of materials that preferentially absorb albumin and that are produced without filler material or peroxide crosslinking techniques may limit the damage to thrombocytes and erythrocytes and consequently decrease the risks for hemorrhages and anemia for the patient. However, since other parts of the extracorporeal circuit such as oxygenators and suction (chapters five and six) play a predominant role in causing blood damage, only limited advantage can be expected from improvements in tubing material alone.

CHAPTER 4: INFLUENCE OF THE BLOOD PUMP

4.1. PREFACE

This chapter will describe the hematological alterations caused by three different blood pumps: roller pump, rotor pump and centrifugal pump.

4.2. SERIES IV: ROLLER PUMP VS SERIES II: ROTOR PUMP

4.2.1. Introduction

In paragraph 4.2. two different types of blood pumps are compared in otherwise identical circuits consisting of SFSR tubing (see figure 2.5.2.). In one series an almost completely occlusive double head roller pump (2.3.2.1.) was employed, while in the other series a novel rotor type of pump was incorporated (2.3.2.2.). In the latter the blood is pumped by a rotor with three roller heads which push the blood forward at a relatively low speed.

Both series consist of six experiments. All dogs were long term survivors and no complications were encountered.

4.2. Series IV: roller pump vs series II: rotor pump

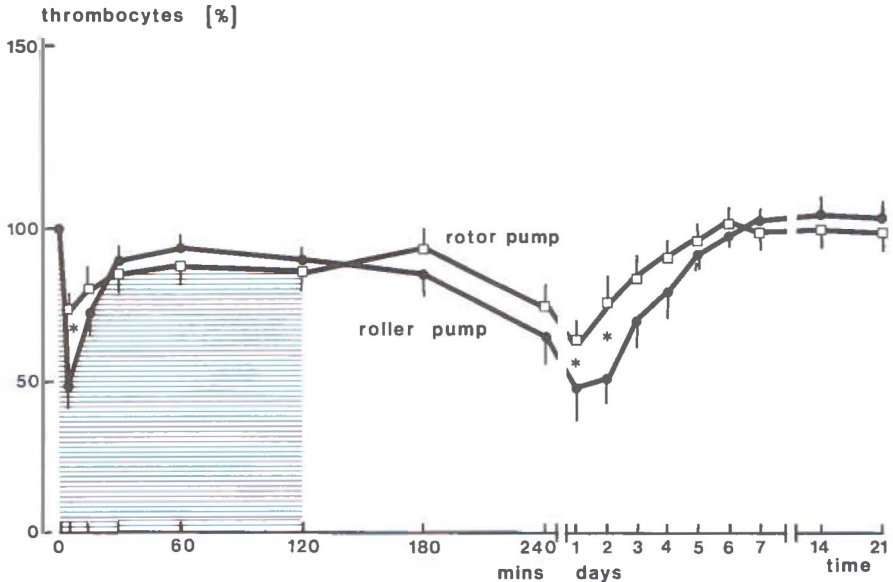

Figure 4.2.2. Percentage of thrombocyte number

After initiation of an ECC with a roller pump the number of thrombocytes immediately fell to 49 % of the initial count corresponding to about $110 \times 10^9/l$. The circuit with the rotor pump showed a significantly less pronounced initial dip to 73 % ($p < 0.01$). After these initial dips both series showed rapid restoration and from 30 mins onwards till the end of the ECC period the number of circulating thrombocytes in both series stabilized on a level of about 90 %.

After the circuit had been disconnected, the number gradually decreased and reached a minimum value of 46 % in the roller pump series on day one after the operation. With the rotor pump, however, the thrombocyte number first slightly increased after ECC but then decreased to a less pronounced minimum of 64 % on day one. In both series these minima were followed by gradual recoveries of numbers to normal percentages, which were reached on day six after the operation. Significant differences between the series were found on days one and two ($p < 0.05$).

4.2. Series IV: roller pump vs series II: rotor pump
 thrombocyte function : OD_{max} [%]

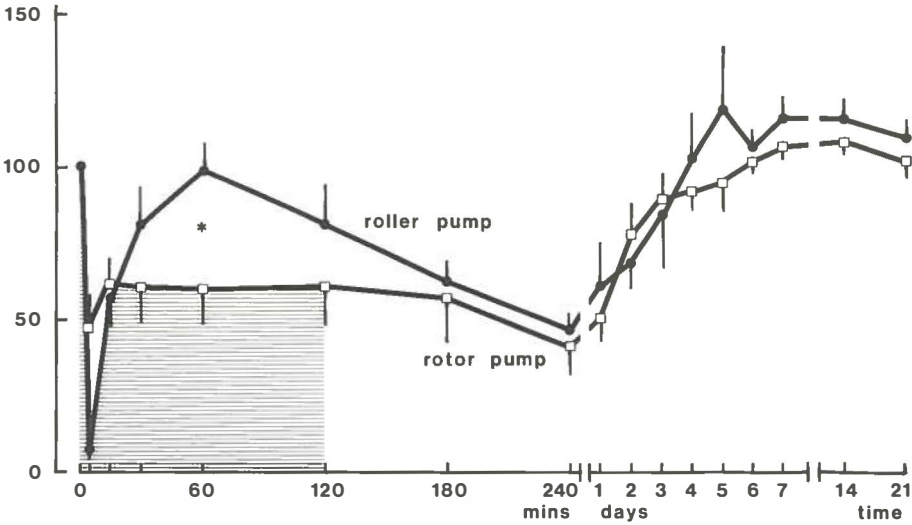

Figure 4.2.3. Percentage of thrombocyte function: $\frac{OD_{max}}{OD_{max}}$

Immediately after the ECC with the roller pump in the circuit had been started, thrombocyte function was largely depressed to 6 %, but it quickly recovered to the normal preoperative value. From 60 mins of ECC onwards the OD_{max} gradually decreased to a minimum of 44 % after 240 mins. In the rotor pump series the course of thrombocyte function showed an initial decrease to 46 % followed by a stable level of about 60 % until the end of ECC. After disconnection of the circuit OD_{max} slightly decreased to almost the same minimum (42 %) at 240 mins as has been observed in the roller pump series. In both series comparable patterns of gradual recovery followed these minima. On day six after the operation preoperative values of OD_{max} were regained.

Significant differences between the series were only present during the ECC period after five ($p < 0.01$) and 60 mins ($p < 0.05$).

4.2. Series IV: roller pump vs series II: rotor pump

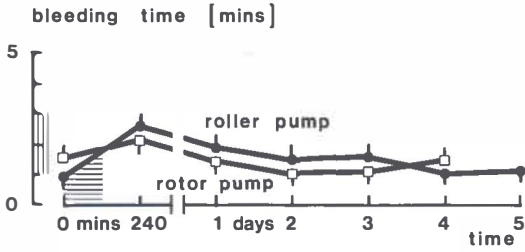

Figure 4.2.4. Bleeding time

The bleeding times showed the same course in both series. At the end of the day of the experiment bleeding times were slightly higher than the preoperative values, but still within the normal range. At all other moments the bleeding times remained between 1-2 mins.

4.2. Series IV: roller pump vs series II: rotor pump

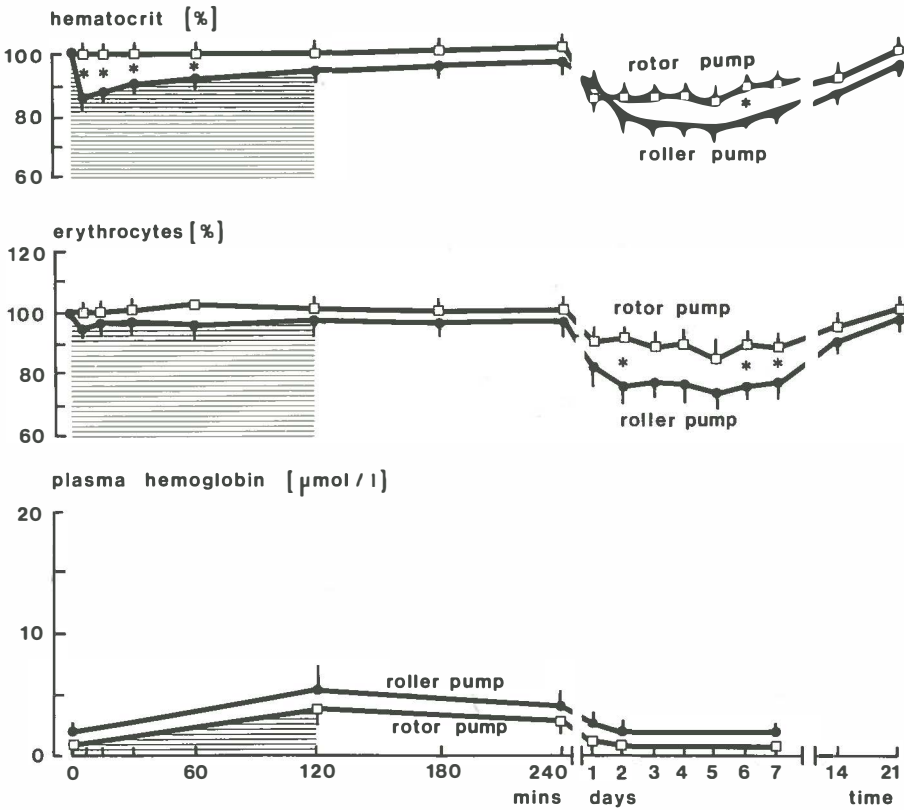

Figure 4.2.5. Percentages of hematocrit and erythrocyte number, and level of plasma hemoglobin

The hematocrit showed significant differences ($p < 0.01$) between the curves during the first hour of ECC as a result of differences in hemodilution (see paragraph 2.2.4.). In the roller pump series the hematocrit initially decreased to 85 % but then gradually increased to 100 % at the end of the day. However, in the rotor pump series no changes were noticed during the day of the experiment. After the operation the hematocrits showed the same patterns as the erythrocyte numbers: in the rotor pump series levels of around 85 % were measured compared with about 75 % in the roller pump series. Preoperative values were reached after three weeks. Only on day six after the operation the difference between the series was significant ($p < 0.05$).

In the experiments with the roller pump the number of erythrocytes was only slightly below 100 % during the day of the experiment. Numbers decreased during the days after the operation to values of around 75 %

and reached preoperative percentages after three weeks. In the experiments in which the rotor pump was incorporated in the circuit the number of erythrocytes did not show any changes during the day of the experiment. After the operation more important differences were noted: the rotor pump series showed a decrease to stabilized levels of about 90 % for a period of one week only, significantly higher than levels of about 70 % in the roller pump series ($p < 0.05$).

Plasma hemoglobin levels increased slightly in both series from 1.5 $\mu\text{g/l}$ before perfusion to 4-5 $\mu\text{g/l}$ at the end of ECC, while 3-4 $\mu\text{g/l}$ was measured at the end of the day. During the subsequent days normal levels were assessed.

4.2. Series IV: roller pump vs series II: rotor pump

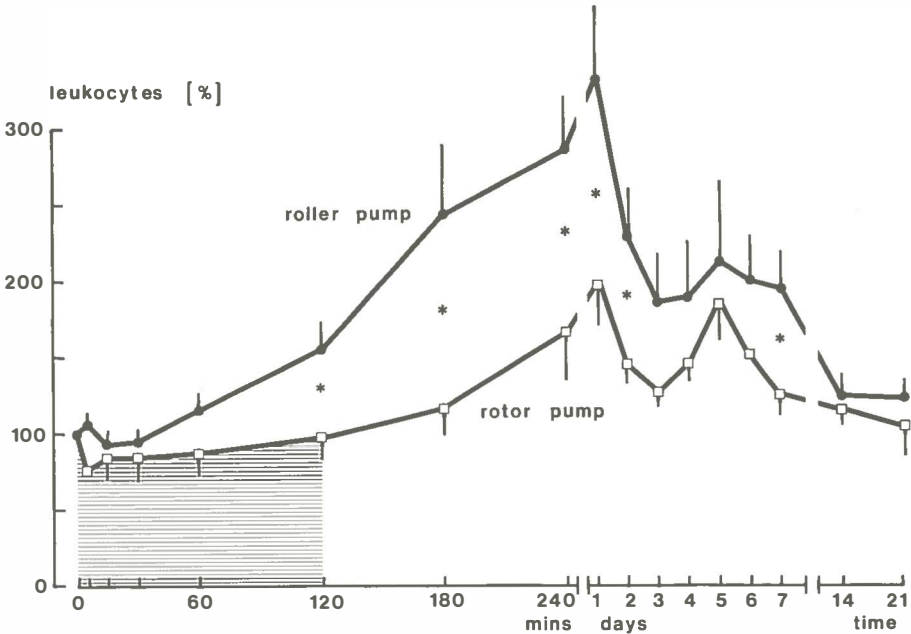

Figure 4.2.6. Percentage of leukocyte number

In the roller pump series of experiments the number of leukocytes increased to a maximum level of 332 % on day one after the operation. The initial leukocyte count was regained after week two. In contrast to this group the rotor pump series of experiments showed a significantly lower course during the whole period ($p < 0.05$). During perfusion with the rotor pump there were only minor changes. After disconnection numbers increased and reached a maximum of 197 % on day one after the operation. Thereafter the same pattern was observed as in the roller pump series and preoperative levels were regained after the first week.

4.3. SERIES V: CENTRIFUGAL PUMP VS SERIES II: ROTOR PUMP.

4.3.1. Introduction

Paragraph 4.3. describes the hematological effects of the centrifugal pump in comparison to the rotor pump as has been described in paragraph 4.2. For both types of pumps SFSR tubing has been employed. In all six experiments the speed of the centrifugal pump has been maintained at about 7000 rpm, equivalent to a blood flow rate of about 3000 ml/min.

In the animals no complications were encountered and all dogs were long term survivors. However, after four experiments a small thrombus was found behind the rotor impeller of the centrifugal pump.

4.3. Series V: centrifugal pump

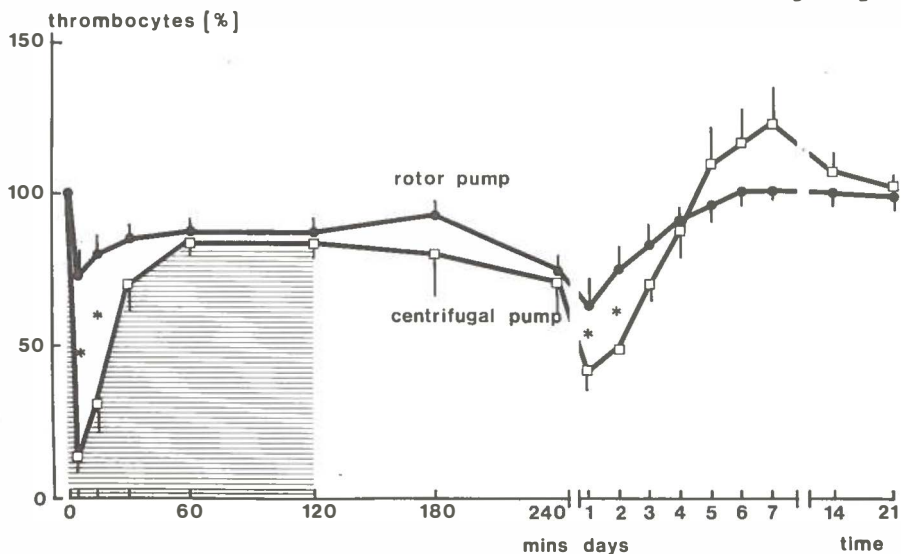

Figure 4.3.2. Percentage of thrombocyte number

The initiation of ECC with the use of a centrifugal pump resulted in an immediate and sharp drop in the number of circulating thrombocytes to 14 %. After 5 and 15 mins the thrombocyte percentages were significantly lower than in the rotor pump series ($p < 0.001$). From 60 mins onwards to the end of the ECC period both series had equal levels of about 86 %. After disconnection of the ECC the number of thrombocytes in the centrifugal pump series showed a gradual decrease with a minimal value of 41 % on day one after the operation. This was significantly lower than the level of 64 % measured in the rotor pump series ($p < 0.05$). In the former the subsequent increase resulted in an overshoot of thrombocytes to about 120 % on days five to seven. After two weeks preoperative values were found.

4.3. Series V: centrifugal pump

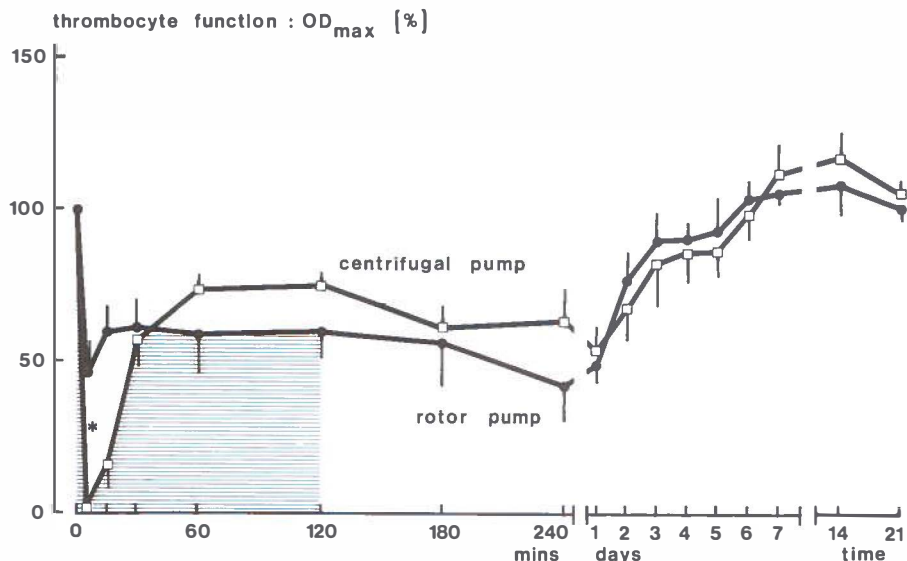

Figure 4.3.3. Percentage of thrombocyte function: OD_{max}

During ECC with the centrifugal pump the course of thrombocyte function was closely related to that of the number of thrombocytes: a deep initial dip to almost zero was followed by a quick recovery to a stable level of 75 % during the second hour of ECC. In contrast the rotor pump series showed a significantly smaller initial dip to 46 % ($p < 0.001$) with a stable level of about 60 % OD_{max} from 30 mins onwards. After disconnection of the ECC both curves tended to decrease. From day one after the operation the functions were identical in both groups and preoperative values were measured from day six onwards.

4.3. Series V: centrifugal pump

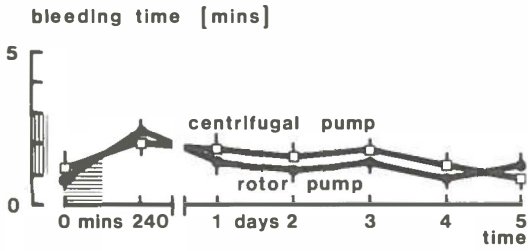

Figure 4.3.4. Bleeding time

The bleeding times showed similar results in both series. At the end of the day of the experiment a slight increase was found, but still normal values of about 2 mins 15 secs were obtained. At all other moments bleeding times were between 1-2 mins.

4.3. Series V: centrifugal pump

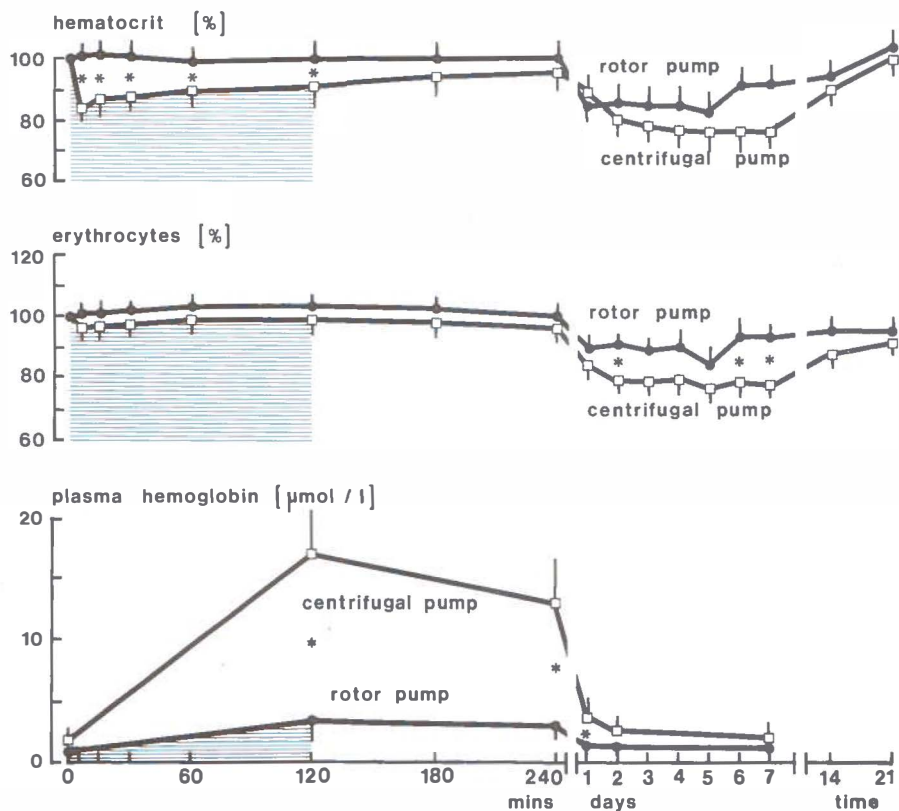

Figure 4.3.5. Percentages of hematocrit and erythrocyte number, and level of plasma hemoglobin

During the day of the experiment hematocrit percentages showed the same differences between both groups as described in paragraph 4.2.5. These differences were caused by the differences in the priming procedure. During the first week after the experiment the hematocrit in the centrifugal pump group showed a stable level of around 78 %, lower than the values of about 85 % in the rotor pump series.

The erythrocyte number in the centrifugal pump experiments showed a minimal decrease to 97 % during the early stage of ECC. This minor decrease was not observed in the rotor pump series. During the rest of the day a level of about 100 % was measured for both groups. In the days after the experiment the centrifugal pump experiments revealed a decrease in numbers to about 80 % for a period of a week, in contrast to 85-90 % in the rotor pump series.

Normalization occurred during the following weeks.

During the first week significant differences were found between both groups ($p < 0.05$).

The level of plasma hemoglobin was significantly increased in the centrifugal pump series and showed a value of $17 \mu\text{g/l}$ at the end of the ECC period. The following decrease resulted in a value of $13 \mu\text{g/l}$ at 240 mins. From day two onwards normal values were regained. Significant differences with the minimally changed levels of the rotor pump group were apparent after 120 ($p < 0.001$) and 240 ($p < 0.01$) mins and on day one ($p < 0.01$).

4.3. Series V: centrifugal pump

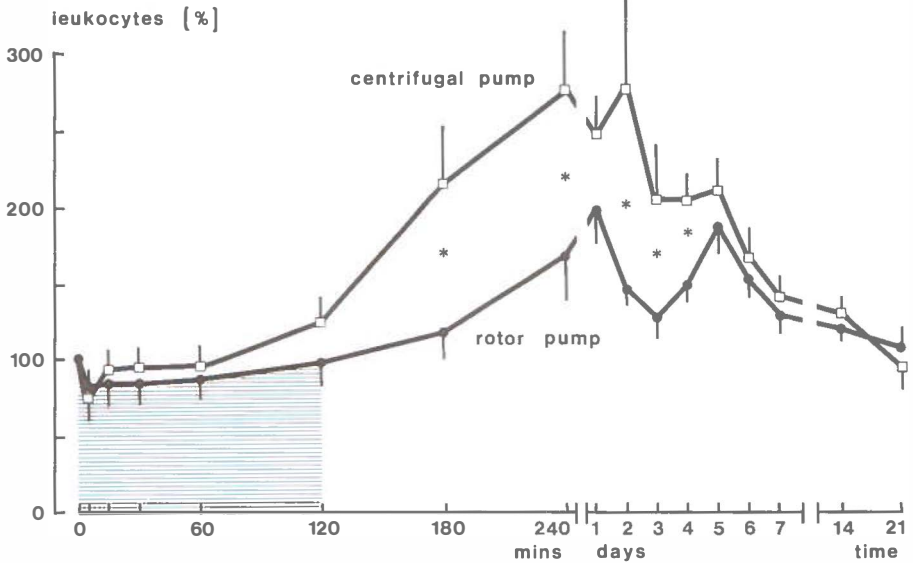

Figure 4.3.6. Percentage of leukocyte number

The centrifugal pump experiments showed a minor initial dip in the number of circulating leukocytes, followed by a stable level of about 90 % for a period of one hour and a gradually developing leukocytosis thereafter. The maximal value of 273 % was reached after 240 mins. In the days after the experiment a somewhat irregular pattern was found with another maximum of 210 % on day five. The preoperative value was recorded after three weeks. Compared to the rotor pump series, the course during ECC was similar, but the leukocytosis after the operation was more prominent and significant differences were calculated after 180 and 240 mins and on days two to four after the operation ($p < 0.05$).

4.4. DISCUSSION

Number and function of the thrombocytes - Comparison of the three different types of blood pump in equal SFSR circuits under standardized conditions provides quantitative differences in hematological response. As far as thrombocyte numbers are concerned, the rotor pump showed the least pronounced initial and secondary dips. The centrifugal pump, on the other hand, resulted in the most expressed initial and secondary dips together with an overshoot in number at the end of the first week. Results obtained in the roller pump series were somewhat in between. Analogous quantitative differences between the groups were seen in the initial dip of the thrombocyte function. These parallel alterations in number and function indicate that particularly the centrifugal pump and, to a lesser extent, the roller pump initiate a massive intravascular thrombocyte aggregation at the onset of pumping. For these two types of pump the initially massive aggregation is followed by higher thrombocyte functions during the remaining period of perfusion than for the initially less affected function in the rotor pump series. The phenomenon of the initial dip has been explained in 3.5.1.1. by the release of bioamines, mainly originating from the mass of erythrocytes.

The differences in platelet response between the three groups can be attributed to differences in mechanical force between the pumps that cause differences in fluid shear stress (Colantuoni et al., 1977; Lambert, 1979; Mockros et al., 1979; Schmid-Schönbein et al., 1979), to differences in exposure times during which high shear stress is exerted upon the blood cells (Friedman et al., 1970; 1971; Colantuoni et al., 1977; Hellums et al., 1977; 1980; Lambert, 1979), and to occlusive or non-occlusive setting of the pump (Bernstein et al., 1967).

Bleeding time - The minimal changes in the bleeding times, measured shortly after extracorporeal circulation, indicate that the alterations in thrombocyte behaviour do not cause serious impairment of hemostasis.

However, in four instances a small thrombus was found behind the rotor impeller of the centrifugal pump after termination of ECC. Similar observations, which have been made both experimentally (Bernstein et al., 1975) and clinically (Pennington et al., 1982), implicate that the coagulation system is more actively stimulated by this centrifugal pump than by the roller and the rotor pumps.

Number of erythrocytes - The damage of red cells is quantitatively reflected in the levels of plasma hemoglobin, which during perfusion showed the

clearest rise in the experiments with the centrifugal pump. In particular the seals in the centrifugal pump must be considered the major cause of erythrocyte damage (Johnston et al., 1976) because of heat generation (Belenger et al., 1981; 1982) and high shear stresses (Dorman et al., 1969; Olijslager, 1982).

The four times lower values of plasma hemoglobin in the roller pump and rotor pump series indicate that these pumps cause less damage to the erythrocytes than the centrifugal pump. The occurrence of more severe postoperative anemia in the centrifugal pump and the roller pump series than in the rotor pump series has been explained by the early removal of (sub)lethally damaged cells during perfusion (3.5.1.4.). These observations reveal that the rotor pump has the most favourable properties for red cells. The roller pump ranks lower and the centrifugal pump is the most deleterious type. Differences are most likely related to lower shear stresses induced by the rotor pump to the blood elements, because complete occlusion of the tubing does not occur and because the rotor pump operates slowly at maximally 50 rpm. Support for this assumption is given by the work of Olijslager (1982), who tested a similar setup, also consisting of tubing and a roller pump, on dogs. However, he employed blood flows of 400 ml/min in contrast to 3000 ml/min in our experiments. He found that the initial and secondary dips in the platelet parameters were absent. Plasma hemoglobin concentrations were also lower and the anemia after the experiment was less expressed. Olijslager explained the smaller degree of blood cell damage in his experiments by lower shear stresses imposed on the blood.

Number of leukocytes - According to McIntire et al. (1980), leukocytes appear to be the most sensitive cellular elements to shear stress induced trauma. In an extensive review of the relation between such mechanical trauma and leukocyte dysfunction these investigators have described the commonly encountered features, also observed in our experiments, of an initial and rapid ECC induced drop in the number of polymorphonuclear (PMN) leukocytes, followed by a compensatory increase in the number of circulating immature PMN leukocytes.

The observation in our experiments that all three types of blood pump show identical initial dips in the numbers of circulating leukocytes is in agreement with reports (see 3.5.1.5.) that the initial dip is mainly dependent on the material of the circuit. In the present experiments the material was unvariably SFSR.

The measured differences in the degree of leukocy-

tosis after the experiments reflect the degree of shear stress inflicted by the different blood pumps. The less pronounced leukocytosis in the rotor pump series in comparison with the two other pump series is explained by the lower shear stresses induced by the rotor pump and the lower compensatory increases.

4.5. CONCLUSIONS

From the experiments with the three blood pumps it can be concluded that concerning thrombocytes, erythrocytes and leukocytes the rotor pump should be considered a better choice than the roller pump, and that the centrifugal pump is the most traumatizing one, predominantly at the seals. However, as was the case for the improvements gained by alterations in the tubing material, only limited advantage can be expected from optimalization of the blood pump in an extracorporeal circuit, since other parts in that circuit such as oxygenators (chapter 5) and suction (chapter 6) also play a role in causing blood damage.

CHAPTER 5: INFLUENCE OF THE OXYGENATOR

5.1. PREFACE

This chapter describes the hematological alterations caused by different oxygenators (one bubble oxygenator and two membrane oxygenators) in standard circuits and in the optimal circuit.

5.2. SERIES VI: BO VS SERIES VII: TMO

5.2.1. Introduction

Paragraph 5.2. will present the results of the series of experiments in which either a conventional bubble oxygenator (Temptrol type Q 110) (BO) or a membrane oxygenator (Modulung-Teflo 2.25 m²) (TMO) was employed. For reasons of comparison the BO and the TMO were interconnected in the same standard circuit consisting of PVC tubing and two roller pumps (see 3.2.). With the bubble oxygenator, which is an open system, a third roller pump was needed in order to overcome the pressure of the arterial reservoir (figure 2.5.5.).

In the BO series five out of six dogs survived; one dog died 12 days after ECC because of infection. In the TMO experiments all six dogs were long term survivors without complications.

5.2. Series VI: BO vs series VII: TMO

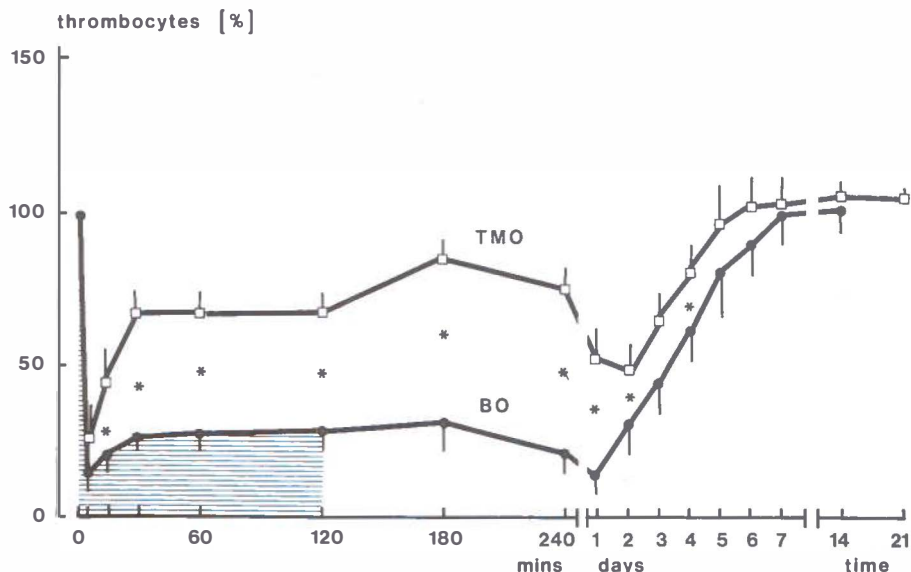

Figure 5.2.2. Percentage of thrombocyte number

The initiation of ECC with either a BO or a TMO in the circuit resulted in an immediate and sharp drop in the number of circulating thrombocytes to comparable values of 21 % and 27 % respectively. These percentages correspond with about $50 \times 10^9/l$ thrombocytes. In the TMO experiments a rapid recovery occurred after this pronounced initial dip and from 30 mins onwards to the end of the ECC period the number of circulating thrombocytes remained on a stable level of about 70 %. In contrast, in the BO series only a minor recovery was observed after the initial dip, resulting in stabilization on a level of about 29 %. These differences between the two series were highly significant ($p < 0.001$). After disconnection of the circuit numbers in the TMO series increased to 92 % after 180 mins and then gradually decreased to 46 % on day one and to a secondary dip of 42 % on day two after the operation. In the BO series the number did not increase after disconnection of the circuit, but decreased and reached a secondary dip of 12 % (equivalent to about $25 \times 10^9/l$ thrombocytes) on day one. Statistically significant differences between the groups were maintained during this period ($p < 0.001$). After these minima numbers in both series equally increased until preoperative values were measured on day 14. Differences between both curves remained significant on days one ($p < 0.001$), two ($p < 0.01$), and four ($p < 0.05$).

5.2. Series VI: BO vs series VII: TMO

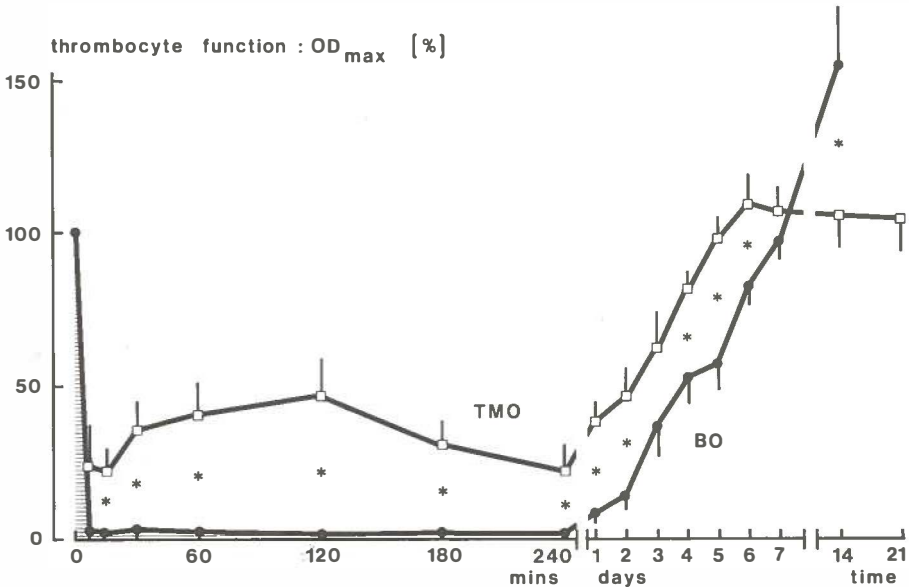

Figure 5.2.3. Percentage of thrombocyte function: OD_{max}

Immediately after ECC had been started with a BO, thrombocyte function was completely depressed and remained so during the day of the experiment, even after disconnection of the circuit. In contrast, thrombocyte function in the TMO series initially fell to 22 % at 15 mins and then recovered to 47 % at the end of the bypass period. After disconnection OD_{max} decreased and reached its minimal value of 22 % at 240 mins. During the days after the experiment OD_{max} increased in both series: in the TMO group OD_{max} reached 100 % on day six, while in the BO experiments a continuing increase was observed with an overshoot to 155 % on day 14 after the operation. The observed differences were statistically significant during the whole experimental period of three weeks ($p < 0.01$).

5.2. Series VI: BO vs series VII: TMO

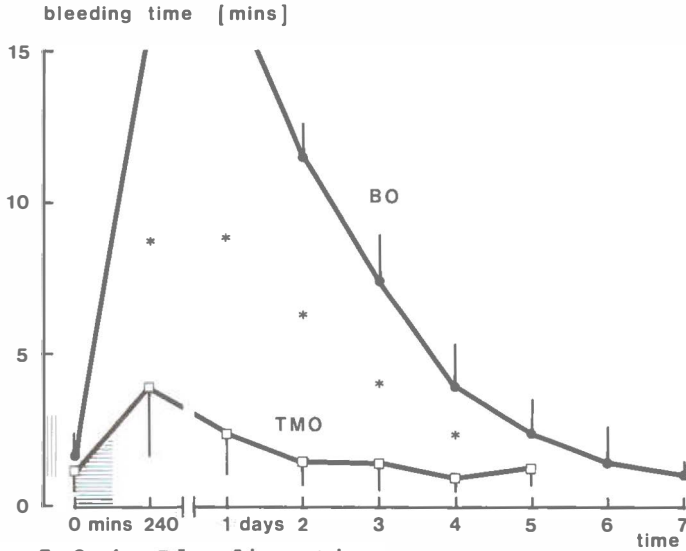

Figure 5.2.4. Bleeding time

In the TMO series the mean bleeding time showed a slightly elevated value of about four mins after the neutralization of the heparin, but the next day it had returned to the normal range. However, in the BO series the bleeding time was greatly prolonged to values of over 15 mins for the period of the day of the experiment and day one. After that a gradual improvement was measured, but preoperative values were not reached until day five. The major differences between the groups were statistically highly significant during this period of four days ($p < 0.001$).

5.2. Series VI: BO vs series VII: TMO

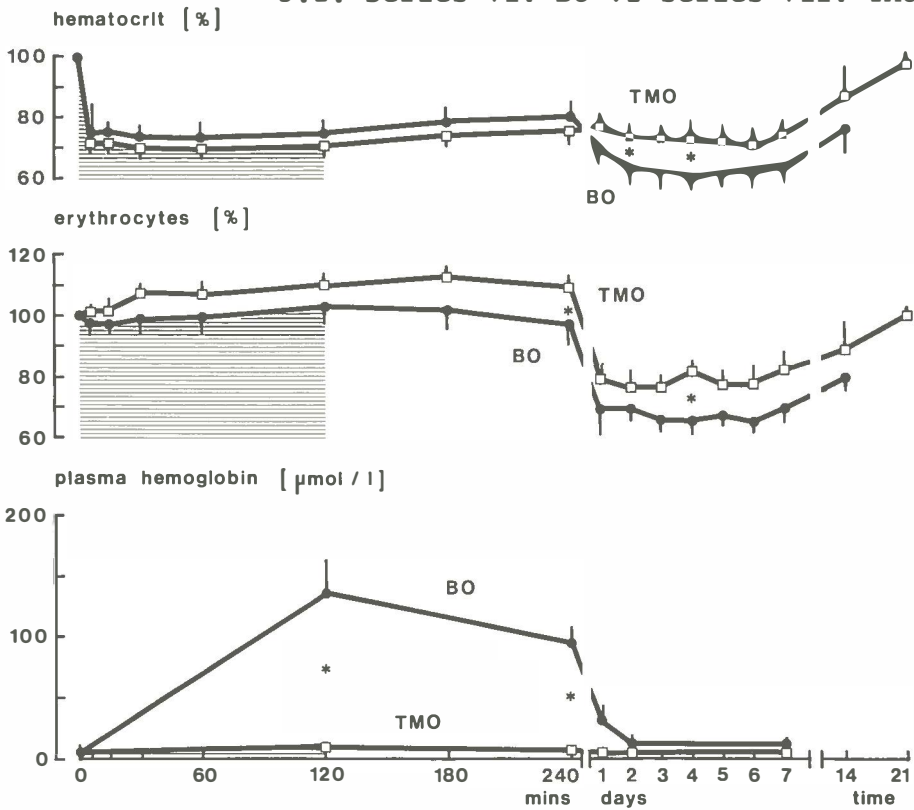

Figure 5.2.5. Percentages of hematocrit and erythrocyte number, and level of plasma hemoglobin

During the day of the experiment the hematocrit showed the same curve for both series: an immediate decrease to 75 % as a result of hemodilution was followed by a gradual increase to about 80 %. During the first week after the operation no clear changes were observed for the TMO group, whereas in the BO group the hematocrit showed another decrease and stabilized between 60 and 65 % for a period of one week. The differences between both groups were significant on days two and four ($p < 0.05$). From the second week onwards hematocrits gradually increased and preoperative values were measured after three weeks.

In the TMO group the number of erythrocytes first showed a slight increase and reached a stable level of 105-110 % until the end of the day of the experiment. In the BO group the number of erythrocytes initially showed no changes but tended to decrease after 180 mins. At 240 mins 97 % was measured, which was significantly lower than 110 % in the TMO group ($p < 0.05$). In the days after the experiment decreases were observed in both groups to values of about 75 %

(TMO) and 65 % (BO). Similar differences of 10-15 % were maintained during the further course, but only on day four there was a statistically significant difference ($p < 0.05$). From day six onwards numbers increased and preoperative values were found after three weeks.

The plasma hemoglobin showed concentrations below 2 $\mu\text{mol/l}$ before ECC. At the end of ECC 135 $\mu\text{mol/l}$ was found in the BO series in contrast to only 10 $\mu\text{mol/l}$ in the TMO series. At 240 mins plasma hemoglobin levels in the BO group had decreased to 95 $\mu\text{mol/l}$ but statistical differences were maintained until normal values were reestablished on day two ($p < 0.001$).

5.2. Series VI: BO vs series VII: TMO

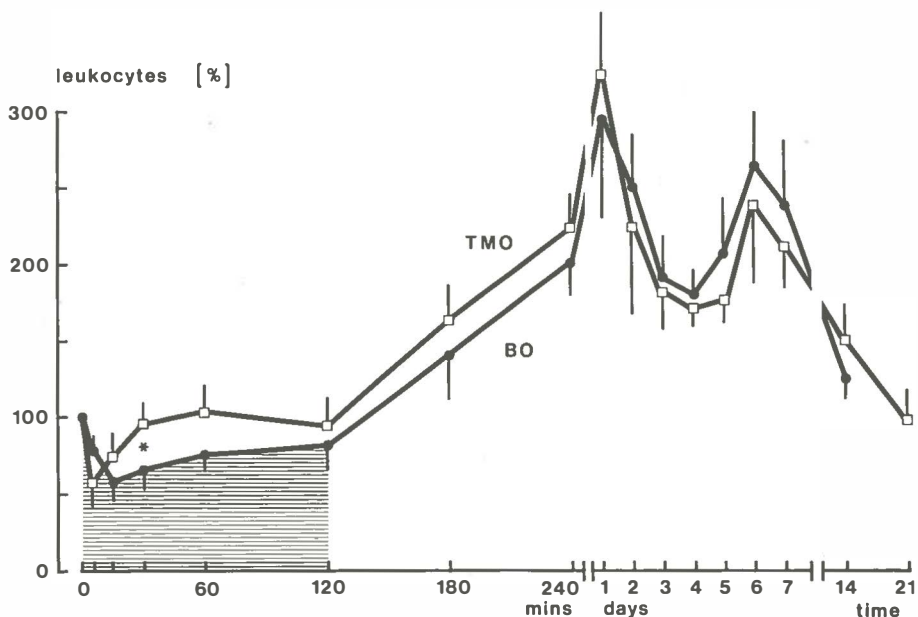

Figure 5.2.6. Percentage of leukocyte number

During the whole period of three weeks similar patterns of changes in leukocyte numbers were obtained for both the BO and the TMO series. Initial decreases of 20-40 % were followed by stable levels, which were somewhat higher in the TMO group (around 100 %) than in the BO group (around 70 %), but this difference was only statistically significant at 30 mins ($p < 0.05$). After disconnection of the circuit a steady increase was seen in both groups with a maximal leukocytosis of about 310 % (equivalent to $30 \times 10^9/l$ leukocytes) on day one. Then the numbers of leukocytes decreased to 175 % on day four, but rose to about 250 % on day six and finally a gradual decrease occurred until preoperative values were measured after three weeks.

5.3. SERIES VIII: TMO IN OPTIMAL CIRCUIT VS SERIES VII: TMO

5.3.1. Introduction

This paragraph will describe the results of the experiments in which the optimally hemocompatible components of the extracorporeal circuit are combined: silica free silicone rubber tubing (see 3.3. and 3.4.), the rotor pump (see 4.2. and 4.3.) and a membrane oxygenator (see 5.2.). The results of these experiments are compared to those of the same oxygenator (TMO) but in the standard circuit of PVC tubing and roller pumps (see 5.2.) to quantify the contribution of the circuit components to the blood damage.

Both series consisted of six experiments in which all dogs were long term survivors and no complications were encountered.

5.3. Series VIII: TMO in optimal circuit

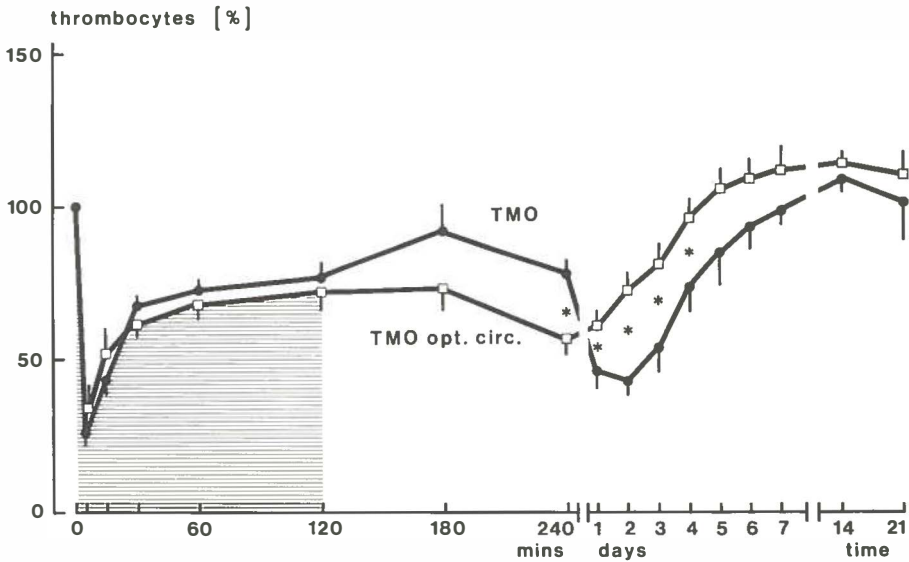

Figure 5.3.2. Percentage of thrombocyte number

During ECC there were no differences in the numbers of circulating thrombocytes between the two groups: in both of them an initial dip to about 30 % was followed by a stable level of about 70 %. After disconnection of the circuit, however, the number initially increased in the TMO in standard circuit series in contrast to a decrease in the TMO in optimal circuit series. At 240 mins significant differences were noted between the values of 78 % and 57 % respectively ($p < 0.01$). The following days showed a reverse situation. The thrombocyte number in the TMO in optimal circuit series steadily increased, whereas the number in the TMO in standard circuit series sharply decreased to a secondary dip of 42 % on the second day. After that numbers recovered in a parallel way. The differences between both groups were significant during days one to four ($p < 0.05$).

5.3. Series VIII: TMO in optimal circuit

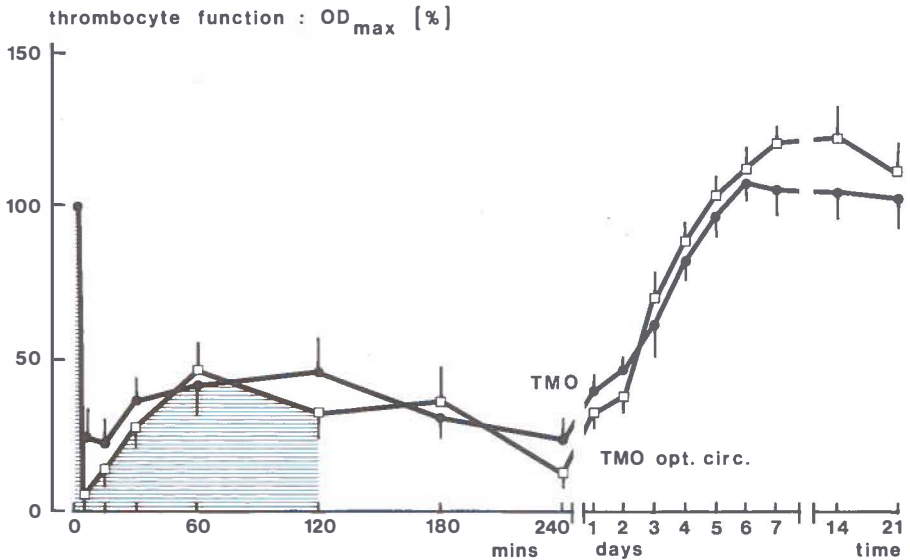

Figure 5.3.3. Percentage of thrombocyte function: OD_{max}

For the function of the thrombocytes almost identical curves were obtained in both groups. Initial minima of 5 and 24 % were followed by increases to 40 % at the end of the ECC period and subsequent decreases to 20 % at 240 mins. After these secondary dips the OD_{max} increased during the following days and from day five onwards normal values between 95-120 % were measured.

5.3. Series VIII: TMO in optimal circuit

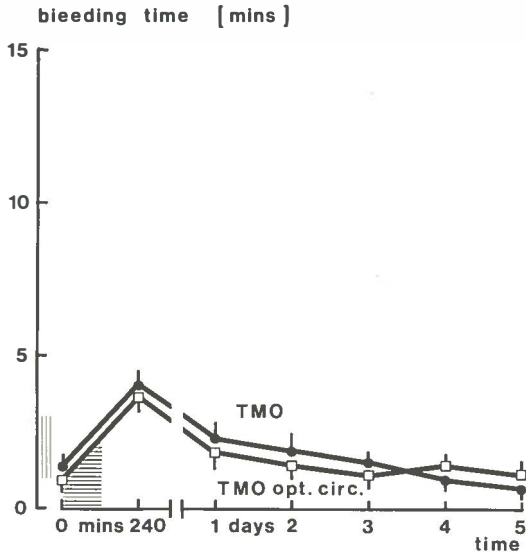

Figure 5.3.4. Bleeding time

Both the TMO in standard circuit group and the TMO in optimal circuit group showed equal patterns in the bleeding time curves throughout the experimental period. Only at 240 mins were slightly lengthened bleeding times of about four mins observed but all other values were within the normal range.

5.3. Series VIII: TMO in optimal circuit

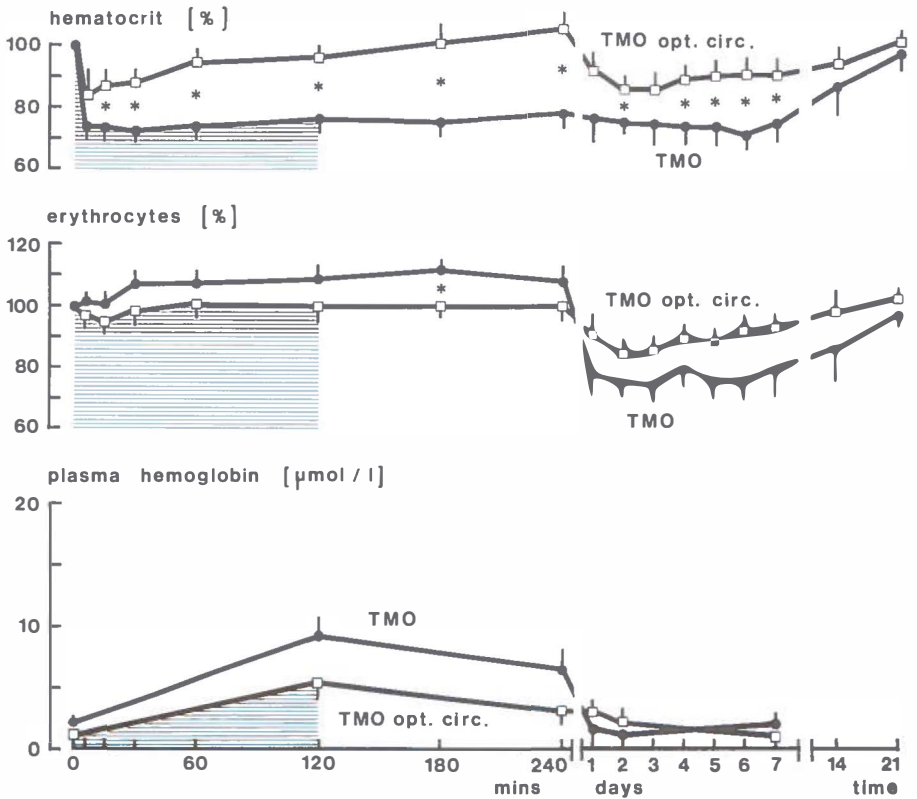

Figure 5.3.5. Percentages of hematocrit and erythrocyte number, and level of plasma hemoglobin

Differences in hemodilution (see 2.2.4.) caused differences in hematocrit decrease: in the TMO in optimal circuit group the hematocrit initially fell to 84 % and in the TMO in standard circuit group to 75 %. However, after that an increase was measured in the optimal circuit group, whereas the hematocrit remained on the 75 % level in the standard circuit group. During the first week after the experiment the hematocrit slightly decreased in the optimal circuit group, but the values remained significantly higher ($p < 0.05$) than in the TMO in standard circuit group. In both groups preoperative hematocrits were regained after three weeks.

In the TMO in optimal circuit series the number of circulating erythrocytes showed few changes during the day of the experiment. The TMO in standard circuit group had slightly elevated values of about 110 % erythrocyte numbers during the day of the experiment. Only at 120 and 180 mins could a significant difference be calculated between the groups ($p < 0.05$). But during the days after ECC the latter series showed the lower curve: decreased values of

about 75 % erythrocytes were measured for a period of one week, in contrast to the TMO in optimal circuit group which showed a stable level of about 85 % in the same period. However, the differences between both groups were not significant. After the first week numbers in both groups increased to preoperative values.

In both series the plasma hemoglobin showed slightly elevated concentrations at the end of ECC: the level of 5.4 $\mu\text{mol/l}$ in the TMO in optimal circuit series was lower than the 9.3 $\mu\text{mol/l}$ in the TMO in standard circuit series, but this difference was not significant. At 240 mins the levels had partially decreased and from day one onwards all values were within the normal range.

5.3. Series VIII: TMO in optimal circuit

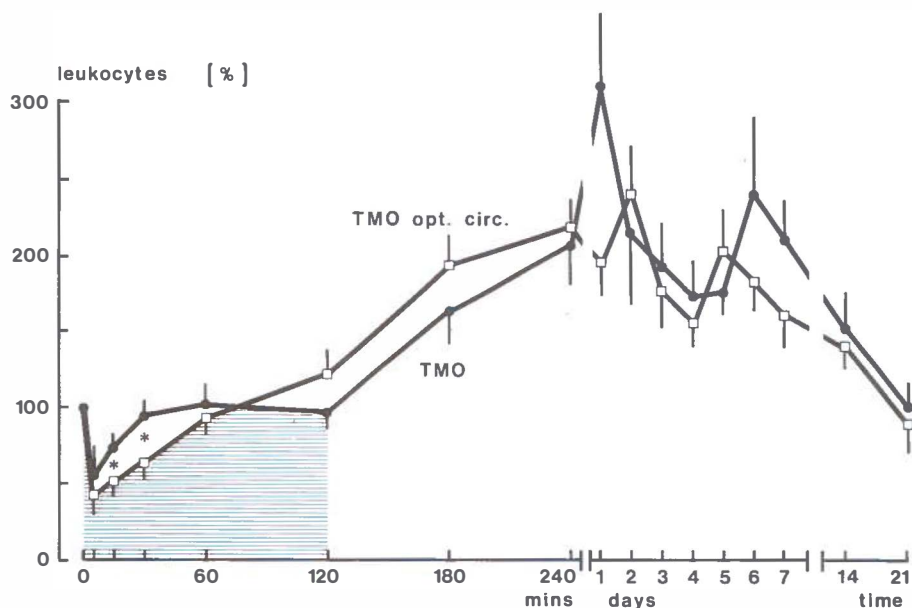

Figure 5.3.6. Percentage of leukocyte number

In both series similar initial dips to about 50 % were observed, followed by recoveries to about preoperative values (100-120 %) at the end of the ECC period. The restoration of number occurred more quickly in the TMO in standard circuit series than in the TMO in the optimal circuit series. After disconnection of the circuit both groups showed comparable increases in numbers with a maximal leukocytosis of 306 % and of 241 % on days one and two respectively. Thereafter in both series numbers decreased to about 165 % on day four after the operation. A second increase on days five and six was measured before the leukocytes gradually decreased to normal numbers after three weeks. Only during the early ECC period could significant differences be observed ($p < 0.05$).

5.4. SERIES IX: KOLOBOW MO VS SERIES VIII: TMO IN OPTIMAL CIRCUIT

5.4.1. Introduction

In this paragraph the results are presented of the Sci-Med spiral coil silicone rubber MO (Kolobow MO) (2.25 m²) in comparison with the TMO (series VIII), consisting of 2.25 m² Teflon microporous membranes. Both types of oxygenator were interconnected in the same extracorporeal circuit as used in 5.3., which consists of silica free silicone rubber tubing and the rotor pump.

All six dogs in both the Kolobow MO and the TMO series were long term survivors without complications.

5.4. Series IX: Kolobow MO

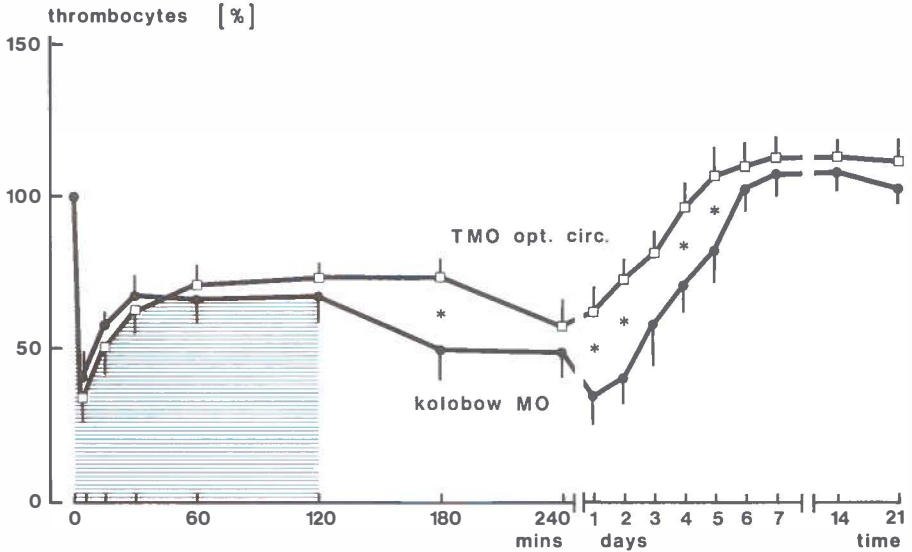

Figure 5.4.2. Percentage of thrombocyte number

During extracorporeal circulation differences were not detected in the number of circulating thrombocytes between the Kolobow MO series and the TMO series: equal initial dips were followed by equal stable levels of about 70 % between 60 and 120 mins. In the early period after disconnection of the circuit the thrombocyte number in the Kolobow MO series decreased to values 10-20 % lower than in the TMO series and at 180 mins this difference was statistically significant ($p < 0.01$). After that the TMO series showed a gradual increase to normal values on day four, whereas the Kolobow MO series decreased to a secondary dip of 34 % on day one after the operation. This dip was followed by a regular pattern of recovery which was located 20-25 % below the curve of the TMO series. Preoperative values were reached on day six. Significant differences between both groups were apparent on days one, two, four, and five ($p < 0.05$).

5.4. Series IX: Kolobow MO

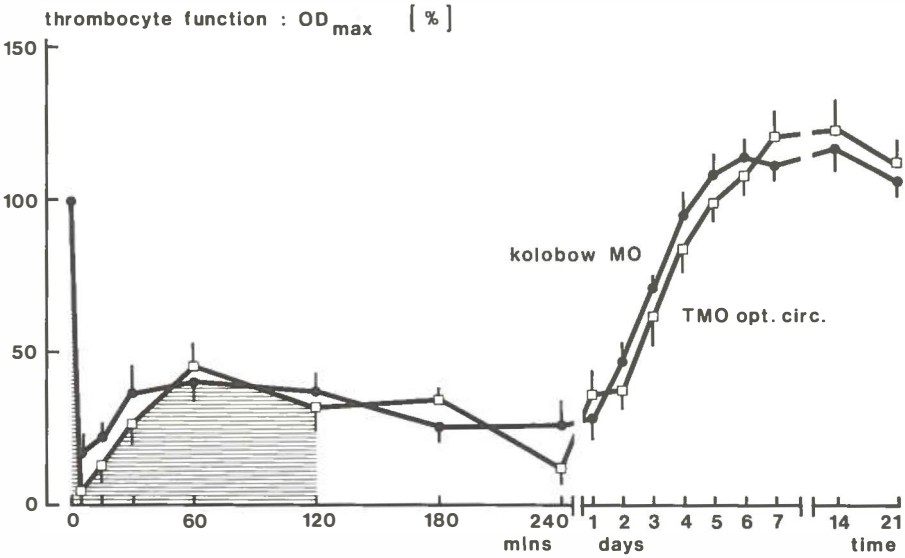

Figure 5.4.3. Percentage of thrombocyte function:
OD_{max}

The Kolobow MO series showed a slightly less pronounced initial dip to 18 % but otherwise followed the pattern of the TMO in optimal circuit group. In both groups partial recoveries to 40 % at 60 mins were followed by gradual decreases with minima of about 20 % at 240 mins. During the postoperative days after ECC both curves were also equal and preoperative values were reached on day four.

5.4. Series IX: Kolobow MO

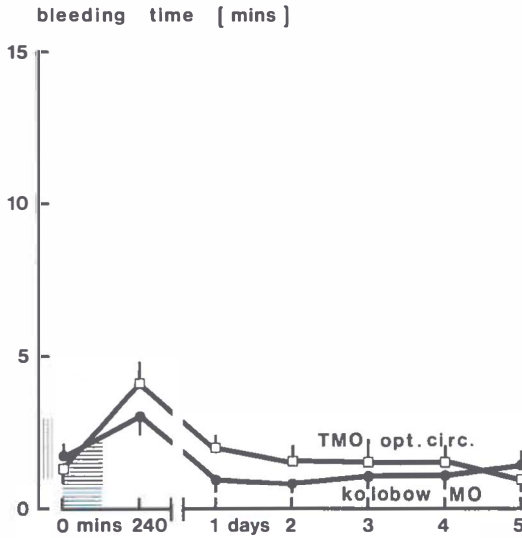

Figure 5.4.4. Bleeding time

For both series of experiments the same general pattern was found. Slightly lengthened values of about four mins were measured at the end of the day of the experiment. On day one after the operation these values had decreased to two mins in the TMO series and one min in the Kolobow MO series. The same difference persisted on day two. Hereafter values of 60-90 secs were measured.

5.4. Series IX: Kolobow MO

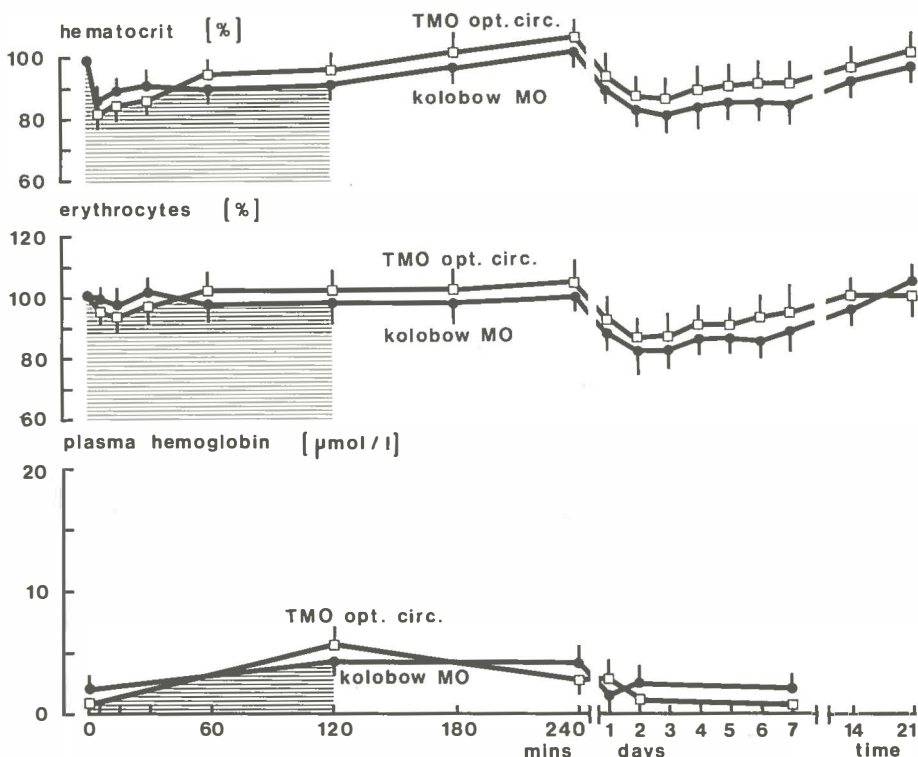

Figure 5.4.5. Percentages of hematocrit and erythrocyte number, and level of plasma hemoglobin

During the whole period of three weeks the hematocrit showed the same curves in both series: immediate decreases to 85 % were followed by gradual increases to about 105 % at 240 mins. During the days after ECC values diminished to about 85 % on day three, remained on this level for a few days, and gradually returned to the preoperative level of 100 % after three weeks.

The number of erythrocytes had equal courses in both series and reflected the changes in the hematocrit values. Except for a small initial decrease to 95 % all values were around 100 % during the day of the experiment. Decreases were seen to about 85 % on day two, followed by stable levels of about 90 % from days four to seven and gradual normalizations thereafter.

The plasma hemoglobin concentration in the Kolobow MO series showed a minor increase to 4.3 $\mu\text{mol/l}$ at the end of the ECC period, compared to 5.4 $\mu\text{mol/l}$ in the TMO series. At 240 mins there were comparable concentrations of about 4 $\mu\text{mol/l}$. Plasma hemoglobin levels further decreased during the following days and showed preoperative values from day two onwards.

5.4. Series IX: Kolobow MO

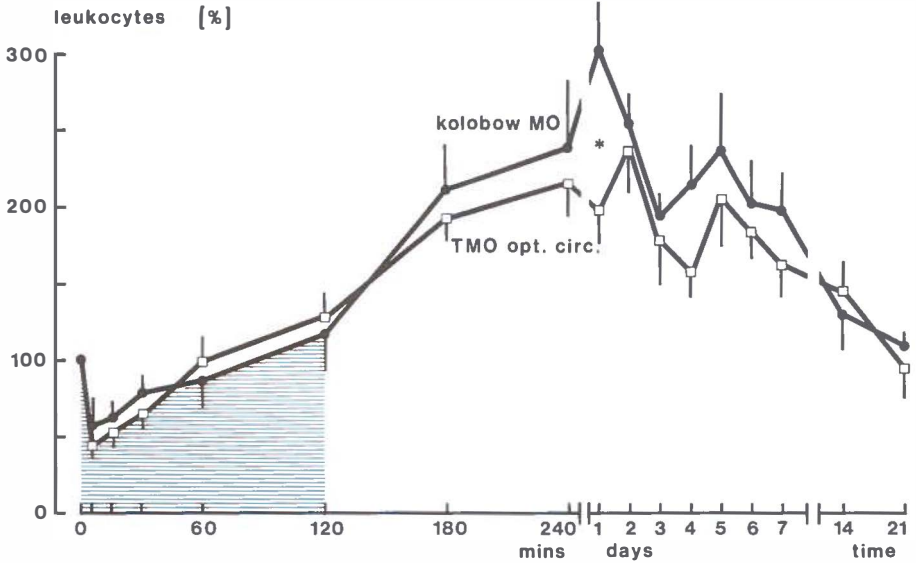

Figure 5.4.6. Percentage of leukocyte number

In both series identical curves were observed during the day of the experiment: initial dips to about 50 % were followed by recoveries to normal values (100-120 %) at the end of the ECC period. Maximal values of 302 % in the Kolobow MO series and 241 % in the TMO series were reached on days one and two respectively. On day one the difference between both groups was statistically significant ($p < 0.05$). Hereafter both groups showed similar and normal patterns resulting in preoperative values after three weeks.

5.5. DISCUSSION

During the last decade there have been conflicting reports and ample discussions on the question whether membrane oxygenators should be preferred to bubble or disc oxygenators for cardiopulmonary bypass. Several authors have expressed the distinct opinion that there are no differences (Kayser, 1974; Hessel et al., 1980; Sade et al., 1980; Trumbull et al., 1980). Others, however, are equally positive in preference for MOs to BOs (Mielke et al., 1973; Solis et al., 1975; Wright et al., 1975; Beall et al., 1976; Galletti, 1976; Heimbecker, 1977; Pierce, 1980; Dewanjee et al., 1981).

Topics in the discussions include:

	reference
hemorrhagic complications	Bachmann et al., 1975 Heiden et al., 1975 Wright et al., 1975 Heimbecker, 1977
hemolysis and anemia	Siderys et al., 1975 Birnbaum et al., 1976
platelet damage	McKenna et al., 1975 Solis et al., 1975
leukocyte destruction and infection	Deggeller et al., 1979 Hakim et al., 1979
protein denaturation	Lee et al., 1961; 1971 Newland, 1977 Fleming, 1979
need for transfusion	McKenna et al., 1975 Heimbecker, 1977 van den Dungen et al., 1983
microcirculation microembolization and organ dysfunction	Pranger et al., 1980 de Leval et al., 1975 Hill et al., 1975 Solis et al., 1975
cerebral complications	Pierce, 1980 Sade et al., 1980 the Lancet, Editorial, 1982
cardiotomy suction	ten Duis et al., 1978

The main difficulty in the attempts to obtain clear evidence of the benefits of using an MO instead of a BO in clinical practice is the poor standardization of the various factors involved that can be achieved in routine cardiopulmonary bypass procedures. Such

strict standardization, which is necessary to assess the implications of modifying one component of the circuit, can be effectuated under experimental, i.e. animal, conditions. In our strictly standardized experimental setup not only distinct differences between BOs and MOs can be demonstrated for the various blood components, but also minor nuances between different MOs, and even between different circuits.

Number of thrombocytes - In accordance with the observations of other investigators (Mielke et al., 1973; Moriau et al., 1977; de Leval et al., 1972; 1975; Addonizio et al., 1978 ; 1979) an immediate and sharp decrease in the number of circulating thrombocytes was found after the start of cardiopulmonary bypass. This massive initial disappearance of thrombocytes has been explained in 3.5.1.1. The dip is partly reversible and the stable levels after half an hour can be regarded as a possible parameter of the hemocompatibility of the extracorporeal circuit involved (de Jong et al., 1977). According to this criterion the significantly higher level of platelet numbers in the TMO experiments (figure 5.2.2.) is indicative for a superior thrombocompatibility for the TMO as compared to the BO. The determining factor for inducing irreversible damage in the bubble oxygenator is the continuously renewed blood/gas interface, which produces uninterrupted denaturation of the plasma proteins (Lee et al., 1961; 1971; Bartlett et al., 1975; Fleming, 1977; Newland, 1977; Salzman et al., 1978) and, in turn, adhesion and aggregation of the thrombocytes (Vroman et al., 1971; Warren et al., 1973; Bartlett et al., 1975). Solis et al. (1975) also reported higher levels of circulating platelets with MOs. In accordance with the work of Kessler et al. (1970) and Dutton et al. (1974) they related this difference to the observation that MOs produce less microaggregates than BOs during perfusion.

Further refinements of the circuits (tubing, pump) or the incorporation of the Kolobow MO in the circuit did not result in measurable improvements in the level of platelet numbers during perfusion (figures 5.3.2. and 5.4.2.). It must be remembered that at this stage platelet numbers only reflect the removal of destroyed thrombocytes from the circulation.

The temporary increase in numbers after the disconnection of the circuit has been explained in 3.5.1.1. by the interruption of the equilibrium between aggregation and disaggregation in favour of the latter. The early elimination of irreversibly damaged thrombocytes from the circulation, as reflected in the secondary dip, is another, and probably more reliable, measure for the hemocompatibility of the

circuit involved (de Jong et al., 1977). In the BO experiments, which already showed low thrombocyte numbers during perfusion and shortly thereafter, there is an almost complete loss of circulating thrombocytes at the moment of the secondary dip (day one after the operation) in contrast to significantly higher platelet numbers and consequently a better hemocompatibility in the series with a MO in the circuit. The minima of the secondary dip not only discriminate between the BO and the TMO, but also between the TMO and the Kolobow MO in favour of the former (figure 5.4.2.).

The obvious idea that a microporous membrane acts as a microbubbler and therefore does not prevent the damaging effect of the blood/gas interface is not supported by these results. It seems more likely that a stable thin albumin layer rapidly covers the "reentrant micropores" (Madras et al., 1980), thus preventing the harm from the continuously renewed blood/gas interface of a bubble oxygenator. On the silicone rubber membranes of the Kolobow MO, however, microscopic gas nuclei remain at the surface despite scrupulously executed priming techniques (Ward et al., 1974; Osada et al., 1977). These gas nuclei are responsible for increased platelet adhesion and aggregation and, consequently, for lower numbers of circulating platelets (Ward et al., 1977).

It is assumed that shear stresses in membrane oxygenators do not play a dominant role in harming platelets. With exposure times of about 10 seconds, common in clinically used MOs, thrombocytes will be activated by shear stresses higher than 20 N/m^2 (Feyen, 1978). This threshold is not reached in currently employed MOs (Olijslager et al., 1979).

The improvements in thrombocyte numbers that were obtained with the optimal circuit consisting of SFSR tubing and the rotor pump (4.2.2.) persisted after interconnection of the TMO. Employment with this oxygenator of PVC tubing in conjunction with the roller pump resulted in a significantly more pronounced secondary dip. For this reason the combination of TMO and optimal circuit is to be regarded as the best choice as far as thrombocyte numbers are concerned.

The main differences between the curves of the TMO in the optimal circuit and of the optimal circuit alone (figure 4.2.2.) are reflected in the initial dips and the levels of thrombocyte numbers during ECC and until day one thereafter. Not only the larger surface area of the membrane oxygenator must be held responsible for the greater platelet damage during ECC (Addonizio et al., 1978), but also the larger pressure difference across the blood pump when the resistance of a MO is included in the system (Mockros

et al., 1979). The secondary dip shows less difference between both curves, which can be explained by assuming that the additional effect of the oxygenator is reflected in reversible platelet damage.

In all series the restoration of thrombocyte numbers to preoperative values occurs in about one week and shows parallel courses after the secondary dip. Assuming that new thrombocytes are normally formed at a rate of 15-20 % (equivalent to $30-40 \times 10^9/l$) per day (Spurling, 1977; Penington, 1981), normal numbers can indeed be expected within one week after ECC. This period of thrombocytopenia is also in accordance with the clinical reports from Moriau et al. (1977) and McKenzie et al. (1969), who measured periods of depressed platelet numbers after cardiopulmonary bypass of three and six days respectively. Such periods have also been described in animal experiments (Berger et al., 1974; Fong et al., 1974).

Thrombocyte function - Several investigators have reported decreased platelet function during ECC (Mielke et al., 1973; Bloom et al., 1974; Bick et al., 1976; Moriau et al., 1977; McKenna et al., 1979; van den Dungen et al., 1982). In the BO experiments thrombocyte function is completely depressed during the period of ECC and the rest of the day of the experiment. This means that even the few thrombocytes still circulating during that period do not respond to stimulation with ADP anymore. Only with the formation of new platelets in the subsequent days thrombocyte function gradually returns. In our experiments with the MOs thrombocyte function shows a pattern comparable to that of thrombocyte numbers: the initial dip reflects the fact that the still circulating platelets are less active than the ones that have aggregated and disappeared from the circulation. The return of function and the stabilization after half an hour suggest the recirculation of disaggregated platelets. The decrease in function after disconnection of the ECC is caused by the protamine administered to neutralize heparin (see 3.5.1.2.). The restoration of function from day two onwards, which parallels the increase in thrombocyte numbers, shows that a new population of thrombocytes enters the circulation. The recovery of thrombocyte function in the TMO and the BO series shows a constant difference of about 25 %, implying that restoration in the BO series occurs about two days later than in the TMO group. The overshoot in function in the BO series on day 14 can be considered an expression of the increased percentage of young and viable thrombocytes in the total platelet population after the ECC induced exhaustion (Karparkin, 1969, Booyse et al., 1971; Penington et al., 1976).

The use of a different membrane oxygenator or of a

refined circuit revealed no differences in the ODmax: all MO series show identical courses of function during the whole period of three weeks. Considering the differences in thrombocyte numbers, established at the moment of the secondary dip, the similarity of function may imply that particularly the platelets exhausted by the manifold aggregation/disaggregation sequences have been selectively eliminated by the RES (Laufer et al., 1975). The remaining thrombocytes will therefore possess an almost equal functional capacity. However, it must be realized that the test of ADP induced thrombocyte function is not sensitive enough to distinguish small differences in platelet function occurring between the groups (see 3.5.1.2.).

Bleeding time - The results of the bleeding time measurements are consistent with the thrombocyte behaviour in the various groups. In the BO group low platelet numbers together with the absence of function during ECC have invariably resulted in immeasurable bleeding times at 240 minutes. The four or five days of measured increased hemorrhagic risk hereafter was confirmed in our experiments by frequent observations of oozing and hematoma. The advantageous effects of the use of the MOs are clearly reflected: more circulating platelets together with a higher functional capacity result in an only marginally elevated bleeding time shortly after ECC. These results coincide with the absence of clinical signs of an increased bleeding tendency after the operation.

The general correlation of thrombocyte number and function to the resulting bleeding time reveals that bleeding times of over 15 minutes are caused by low numbers together with impaired functions (figure 5.5.). Bleeding times from 3 to 15 minutes are caused by either low numbers or impaired functions (de Jong et al., 1979).

In correlation with the parameter of platelet function the substitution of the TMO by the Kolobow MO or the optimalization of the circuit did not result in differences in the bleeding time. However, the bleeding time test, as the only measure that clinically correlates with "platelet-mediated bleeding" (Levine, 1975), does clearly demonstrate the hemostatic importance of the use of MOs instead of BOs in cardiopulmonary bypass procedures.

In contrast to the significant differences demonstrated in well standardized animal experiments, only a limited number of clinical studies have proved the hemostatic superiority of membrane oxygenators to bubble oxygenators convincingly. Van den Dungen et al. (1982; 1983) studied patients undergoing coronary artery bypass grafting, which is considered the most standardized type of operation, comparing the BO with

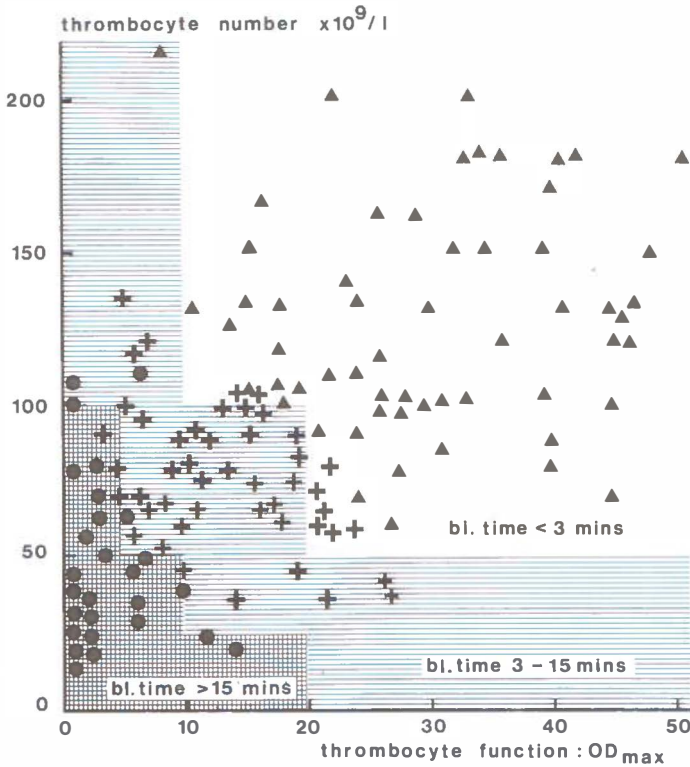

Figure 5.5. The correlation of thrombocyte number and function (corrected according to the nomogram; see 2.7.2.2.) to the resulting bleeding time.

- bleeding time >15 minutes
- + bleeding time 3-15 minutes
- ▲ bleeding time <3 minutes

the MO. They observed significantly more blood loss and an increased transfusion requirement in the BO group while platelet function was better maintained in the MO group. Their conclusion was that clinically hemostasis was also better preserved in perfusions with a membrane oxygenator. This conclusion is also supported by Birnbaum et al. (1979).

In view of the presented experimental data and the well standardized clinical studies and in accordance with critical reviews by Heimbecker (1977), Hill (1978), Pierce (1980), and Wildevuur (1980) the hemostatic superiority of the MO to the BO can no longer be denied. Our data have shown that the choice of a MO and the optimization of the circuit do reduce platelet damage, but do not contribute substantially to the well maintained overall hemostatic capacity in MOs.

Hematocrit, number of erythrocytes and plasma hemoglobin - The differences in damage to the erythrocytes observed in the four oxygenator groups accentuate the differences in thrombocyte behaviour and in the bleeding time. During the day of the experiment the damage inflicted on the red cells is mainly reflected in the levels of plasma hemoglobin as the indication of hemolysis. The highly significant difference between the BO (135 $\mu\text{mol/l}$) and the TMO (10 $\mu\text{mol/l}$) groups at the end of the perfusion period is accompanied by a difference in the number of circulating erythrocytes. The measured difference of 125 $\mu\text{mol/l}$ is caused by hemolysis of 1.2 % of the circulating red cell mass. The remaining difference of 5 % in erythrocyte numbers consists of both sublethally damaged and trapped red cells, and erythrocytes from which the hemoglobin content has already been eliminated during perfusion (see 3.5.1.4.). Obviously the parameter of plasma hemoglobin only represents a part of the total erythrocyte damage.

The plasma hemoglobin levels measured in our experiments are in accordance with the observations made by other investigators in clinical studies. Clear differences between MO and BO in plasma hemoglobin concentrations during ECC have been reported by Siderys et al. (1975), Heimbecker (1977), and van den Dungen et al. (1982). Others (Liddicoat et al., 1975; Lamberti et al., 1976; Clark et al., 1979) did not notice any differences between MO and BO, but this must be attributed to incomparable operation conditions, in which for instance the interfering effect of cardiotomy suction was not strictly controlled.

When the TMO is used in the optimal circuit, there is less damage to the erythrocytes than in the combination with the PVC circuit and the roller pump. Figure 5.4.5. shows that, while the type of circuit does contribute to the red cell damage, no influence can be attributed to the type of membrane oxygenator that is incorporated in the circuit: at 120 minutes the values for plasma hemoglobin, hematocrit and percentage of circulating erythrocytes are equal for the TMO in optimal circuit and the Kolobow MO groups. These findings support the conclusions from 4.4. that ECC induced damage to the erythrocytes is primarily caused by the mechanical forces of the pumps.

The development of postoperative anemia substantiates the reports of ECC induced red cell damage and provides a more reliable parameter for erythrocyte damage than the measure of plasma hemoglobin (Galletti, 1965; Birnbaum et al., 1977; van den Dungen et al., 1982). Not only does it reflect the direct destruction during perfusion, but also the

elimination of sublethally damaged erythrocytes (see 3.5.1.4.). The anemia after ECC shows the same consequence of the four groups: the bubble oxygenator reveals the most severe anemia while both membrane oxygenators have equally higher erythrocyte levels. When incorporated in an optimal circuit, both beneficial effects of oxygenator and circuit, are manifest.

Number of leukocytes - Leukocytes are considered to be at least as sensitive to shear stress inflicted damage as platelets and probably more susceptible than erythrocytes (McIntire et al., 1981). Their reaction to such a trauma is probably mostly aspecific (Veenhof, 1976; Hakim et al., 1979). The practical consequence of aspecificity is that similar patterns of changes in leukocyte numbers are measured in all four series of experiments: they show similar, material dependent, initial decreases with rapid recoveries, followed by "camel-hump" shaped, shear stresses dependent, leukocytoses and restoration of normal values after three weeks. The favourable quantitative difference in reactive leukocytosis in the blood pumps series (see 4.2.6.) is eliminated after incorporation of the oxygenator. This is most likely explained by the large surface area of the membrane oxygenator in addition to the circuit, leading to increased adherence and reactivity. It exhausts the compensating mechanism of quick release from the marginating pool and from the bone marrow and thus veils the improvement gained with the circuit.

Probably more decisive is probably the effect of the variables on leukocyte function (see 3.5.1.5.). In a previous study (de Jong et al., 1977) differences were observed between the TMO and the Modulung MO for carbonyl-iron phagocytosis. The lower functions in the Modulung MO experiments coincided with higher septicemia after ECC. This decrease in leukocyte function might be due to complement activation and consequent consumption during ECC. The activation of complement by the alternative pathway has been related to specific materials such as cellophane membranes of hemodialyzers (Craddock et al., 1977; Hakim et al., 1980; Jacob et al., 1980) and also silicone rubber membranes (Jacob et al., 1980), but can also be stimulated by nylon screens (Jacob et al., 1980; Chenoweth et al., 1981) or the blood/air interface (Chenoweth et al., 1981). It has been discussed in 3.5.1.5. that the activation of particularly C5a is held responsible for the initial dip in leukocyte numbers at the onset of bypass, inducing massive leukocyte aggregation. This latter phenomenon may be important in relation to enhanced microcirculation in organs (Hammerschmidt et al., 1979; Pranger et al., 1980) during and after bypass and particular-

ly with reference to the so-called "postperfusion" lung dysfunction. Hence the secondary effects of leukocyte damage and complement consumption are more important than the loss of leukocytes as such.

Addendum

Recently a newly developed hollow fiber membrane oxygenator made of microporous polypropylene (Capiox, Terumo, 1.6 m²) with or without an integrated heat exchanger has been tested in our laboratory under somewhat modified experimental conditions (Ennema et al., 1983). Two groups of six dogs each underwent partial bypass during two hours (flow 2 l/min) and were examined for changes in the numbers of blood cells, the platelet function, the concentration of plasma hemoglobin and aggregate formation.

Under these altered experimental conditions of flow, circuit and membrane oxygenator surface area the Terumo MO showed better preservation of platelet numbers and functions than both the TMO and the Kolobow MO. Numbers of leukocytes and erythrocytes and plasma hemoglobin concentrations did not differ markedly. The Terumo MO did not reveal thrombocyte aggregates as assessed by the Wu-Hoak platelet aggregation index (Wu et al., 1974; David et al., 1982) for the difference between the in- and outflow side of the oxygenator. Further experimental and clinical evaluation is necessary, but the Terumo MO might be hematologically superior and easier to handle than the TMO and the Kolobow MO.

5.6. CONCLUSIONS

The incorporation of different types of oxygenators in an extracorporeal circuit results in larger hematological differences than measured in previous chapters with respect to the tubing materials and the blood pumps. Especially the use of a bubble oxygenator has a definite traumatizing impact revealed in all blood elements, which results in disturbed hemostasis and severe anemia. Membrane oxygenators yield much more favourable results. Among them the TMO provides a somewhat better hemocompatibility than the Kolobow MO. Only thrombocyte numbers are better maintained with the TMO, but thrombocyte function, erythrocyte damage or leukocyte behaviour show no differences. When the TMO is combined with the hematologically superior circuit of SFSR tubing and rotor pump, the benefits from this optimal circuit are added to the benefits gained by using a membrane oxygenator.

CHAPTER 6: INFLUENCE OF THE CARDIOTOMY SUCTION

6.1. PREFACE

This chapter describes the hematological alterations caused by two different methods of cardiotomy suction: suction of blood (400 ml/min) from the thoracic cavity with air (1000 ml/min) and without air.

6.2. SERIES XI: TMO + HIGH VACUUM SUCTION VS SERIES VII: TMO AND SERIES VI: BO

6.2.1. Introduction

In this paragraph the results are presented of experiments in which high vacuum cardiotomy suction (approximately 400 ml/min blood + 1000 ml/min air) has been additionally employed during total cardiopulmonary bypass using a membrane oxygenator (TMO). As a comparison the results are given of the previously described BO and TMO experiments (series VI and VII). This series of experiments is meant to imitate the common clinical situation in open heart surgery, in which high vacuum cardiotomy suction is used extensively to keep a dry operating field. This implicates that blood is vigorously mixed with air in the suction circuit.

In the following figures the two hours' period of extracorporeal circulation is represented by the horizontally shaded area. The periods of cardiotomy suction are given by a doubly shaded area.

In this series four experiments were performed. Two dogs died in the first night after the operation because of hemothorax and two dogs were long term survivors. Since the number of surviving dogs in series XI is too small to permit statistical comparison during the days after the experiment, the data of the high vacuum suction group during this period are only given to show trends of recovery. Consequently the differences between the groups will be statistically analysed during the day of the experiment only. In this series plasma hemoglobins have not been determined.

6.2. Series XI: TMO + high vacuum suction

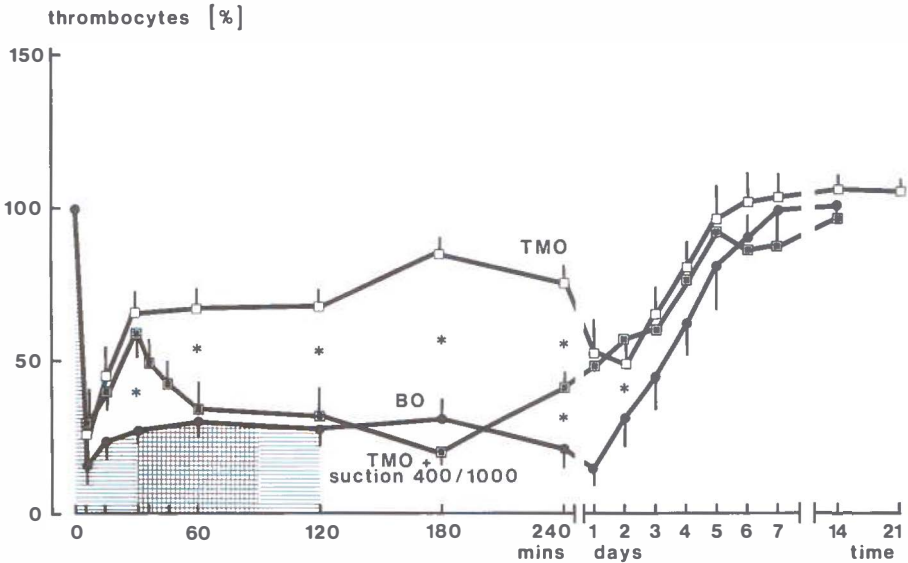

Figure 6.2.2. Percentage of thrombocyte number

In the period before the initiation of cardiotomy suction similar changes were observed as described (see 5.2.1.) for the TMO series. The start of high vacuum suction (doubly shaded area) after 30 mins of MO perfusion resulted in a second, persistent, drop in the number of circulating thrombocytes from 65 % to about 30 %, a level equal to that in the BO series. The differences with the TMO series without suction were statistically highly significant ($p < 0.001$). After disconnection of the ECC the number further decreased to 20 % (equivalent to $26 \times 10^9/l$) in the MO + high vacuum suction group at 180 mins in contrast to a recuperation to 92 % in the TMO series without suction. The differences between the TMO series and both other series remained significant ($p < 0.001$). The thrombocyte number in the TMO + high vacuum suction group tended to recover rapidly during the first days after the experiment, whereas in the other groups numbers decreased and showed secondary dips of 42 % and 12 % respectively. After the first days all three groups showed similar courses of restoration.

6.2. Series XI: TMO + high vacuum suction

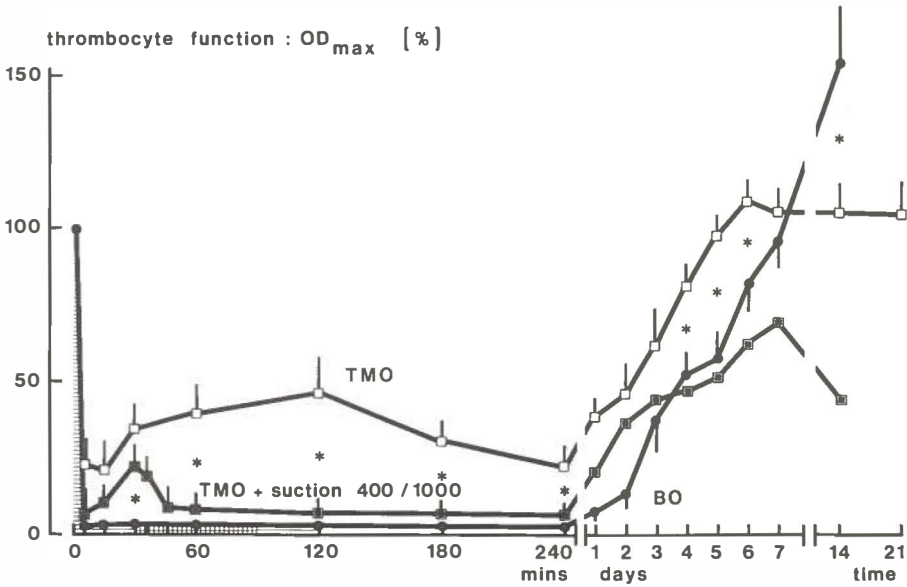

Figure 6.2.3. Percentage of thrombocyte function: OD_{max}

The initiation of extracorporeal circulation resulted in an acute disappearance of the thrombocyte aggregation, which in the TMO series partially recovered in 30 mins (see 5.2.3.). After institution of cardiomy suction the function rapidly decreased further to the minimal level previously observed in the BO series. No recovery of function was observed after disconnection of the circuit, whereas in the TMO series without suction a significantly better function was maintained ($p < 0.01$). During the first days after the experiment the recovery of function in the TMO + high vacuum suction group showed a course comparable to the other series.

6.2. Series XI: TMO + high vacuum suction

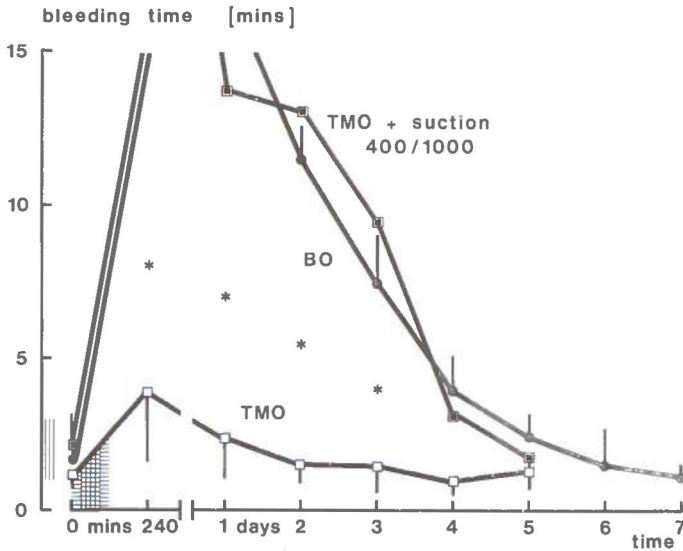

Figure 6.2.4. Bleeding time

In the TMO + high vacuum suction group the bleeding time showed the same changes after ECC as in the BO group and the differences with the TMO group without suction were also statistically highly significant ($p < 0.001$). At the end of the day of the experiment the values had lengthened to more than 15 mins, while gradual improvement was seen in the subsequent days and normal values were reached on day four. In contrast, almost normal values were measured in the TMO series without suction after the experiments.

6.2. Series XI: TMO + high vacuum suction

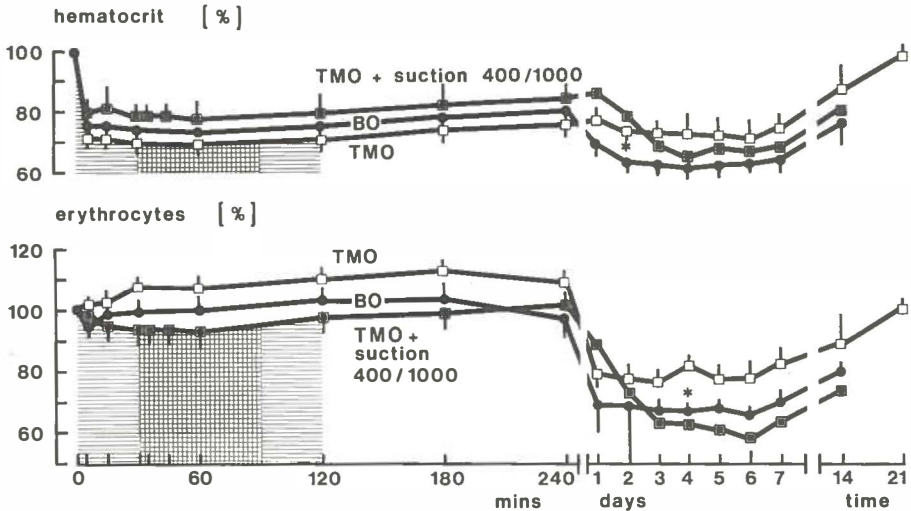

Figure 6.2.5. Percentages of hematocrit and erythrocyte number

In the three groups of experiments the hematocrits showed similar decreases to values of about 75-80 % during the day of the experiment. During the days after ECC decreased levels of about 65 % were found in the TMO + high vacuum suction series and the BO series while in the TMO group without suction hematocrits were slightly higher with values of about 75 %. Preoperative values were regained after three weeks.

In the TMO + high vacuum suction group the number of circulating erythrocytes showed a slight decrease during ECC with a minimum of 94 % at 60 mins. Hereafter the number gradually increased to 101 % at the end of the day. In the TMO series without suction and the BO series constant levels of about 108 % and 98 % respectively were measured. During the days after perfusion the erythrocyte number in the TMO + high vacuum suction group followed the level of the BO group, whereas 15 % higher values were found in the TMO group. From day six onwards numbers increased in all groups and reached normal preoperative values after three weeks.

6.2. Series XI: TMO + high vacuum suction

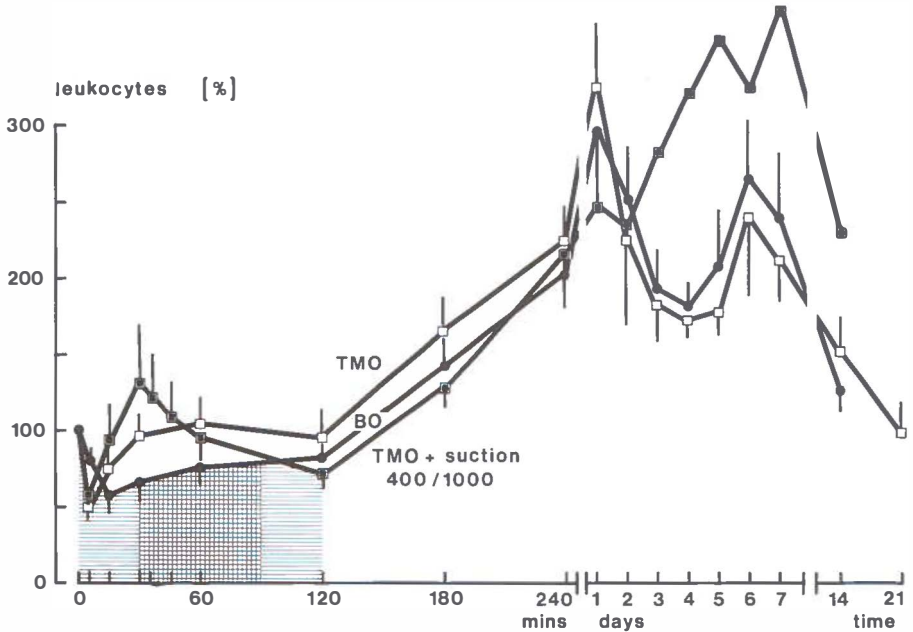

Figure 6.2.6. Percentage of leukocyte number

Before the initiation of cardiotomy suction this series revealed similar changes as described for the TMO series (chapter 5.2.6.). The introduction of suction after 30 mins of ECC resulted in a second decrease in leukocyte numbers to 79 % at the end of bypass. In the early period after perfusion all three groups showed upward courses to maximal leukocytoses and decreases thereafter. However, after the second day the number of leukocytes in the suction group increased to substantially higher values than in both other series. After two weeks the number of leukocytes in series XI were still not back to normal.

6.3. SERIES X: TMO + CONTROLLED SUCTION VS SERIES VII: TMO AND SERIES VI: BO

6.3.1. Introduction

This paragraph presents the results of experiments in which perfusion with the TMO was combined with electronically controlled cardiotomy suction to prevent suction of air with blood. This system basically consists of blood sensing electrodes at the tip of the sucker and a regulating device which controls the speed of a roller pump according to the blood level (see 2.3.4.2.). By means of this regulating system the blood level is always kept above the opening in the tip of the sucker and air is prevented from entering the suction line. In this series of experiments the composition of the priming fluid was different to that of most other series (see 2.2.4.). The results of the TMO + controlled suction group are again compared with the TMO and BO groups without suction (see 5.2.). In this series six experiments were performed. One dog died shortly after perfusion and two dogs during the second night because of hemothorax while three dogs were long term survivors. On the first day after the experiment there were still sufficient survivors to permit statistical comparison and from day two onwards data are given to show the trend of recovery.

6.3. Series X: TMO + controlled suction

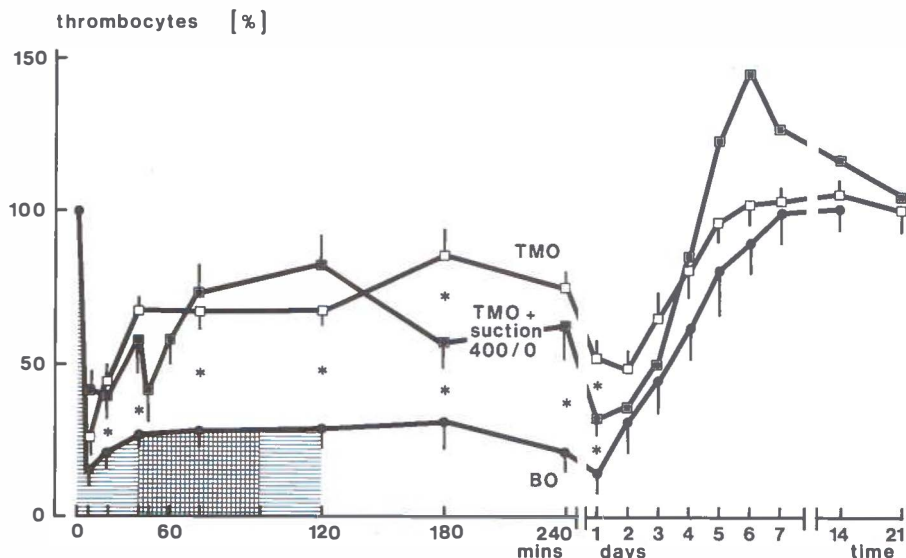

Figure 6.3.2. Percentage of thrombocyte number

Before cardiotomy suction was started (shaded area), mean thrombocyte values of the TMO series with and without suction were similar: initial dips to 35-40 % at 5 mins were followed by increases to about 60 %. The initiation of controlled suction (doubly shaded area) resulted in a second drop to 41 % at 35 mins. This drop was transient and numbers recovered to a stable level of about 75 % for the remaining period of ECC. This level was equal to that of the TMO series without suction. After disconnection of the circuit the number of thrombocytes in the controlled suction series initially decreased in contrast to the TMO series. The value of the secondary dip (32 % on day 1) was located in between those of the TMO and BO groups. The values in the TMO + controlled suction series were significantly higher than in the BO series from 15-240 mins ($p < 0.001$). Significant differences between the TMO series with and without suction were only found at 180 mins ($p < 0.01$). In the controlled suction group the thrombocyte number tended to be restored more quickly and to develop an overshoot with a maximum on day six. Hereafter the number returned to the preoperative value in three weeks.

6.3. Series X: TMO + controlled suction

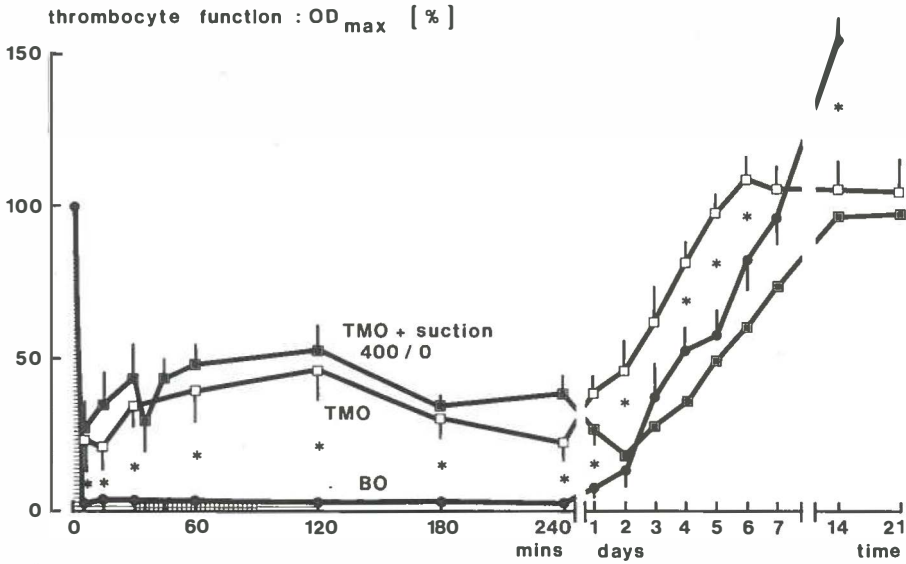

Figure 6.3.3. Percentage of thrombocyte function: OD_{max}

Throughout the day of the experiment the same course of thrombocyte function was observed in the TMO + controlled suction series as in the TMO experiments without suction (see 5.2.3.). The start of suction briefly interrupted the regular pattern with a transient dip to 30 %. In contrast, in the BO experiments OD_{max} was almost completely abolished during the day of the experiment. After disconnection of the circuit the TMO + controlled suction experiments showed a pattern of recovery similar to that in the BO series. Both the TMO + controlled suction series and the TMO series without suction showed significantly higher thrombocyte functions than the BO series from 5-240 mins ($p < 0.001$).

6.3. Series X: TMO + controlled suction

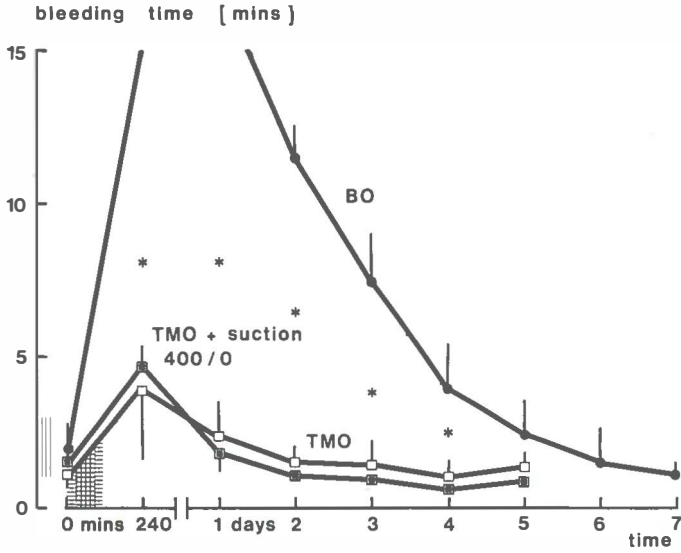

Figure 6.3.4. Bleeding time

During the whole experiment the bleeding time in the TMO + controlled suction series closely followed the course of the TMO series without suction. The same highly significant differences ($p < 0.001$) were also found in comparison to the BO series ($p < 0.001$).

6.3. Series X: TMO + controlled suction

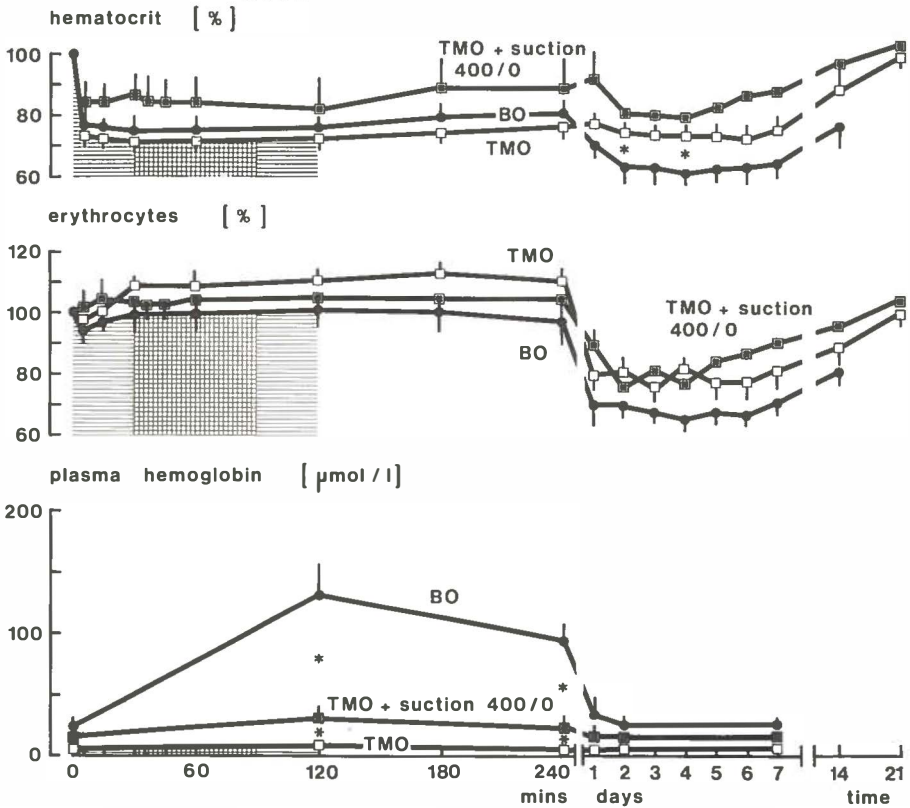

Figure 6.3.5. Percentages of hematocrit and erythrocyte number, and levels of plasma hemoglobin

As a result of a slightly altered priming fluid (see 2.2.4.) the hematocrit in the TMO + controlled suction group initially decreased to 85 %. The further course during the day of the experiment revealed a gradual increase to 90 % at 240 mins. In the TMO and the BO series without suction slightly lower hematocrit values of about 75 % were measured. During the days after the experiment higher hematocrit levels remained in the TMO + controlled suction series. All hematocrits improved from day four onwards to normal values after three weeks.

In the TMO + controlled suction series the number of circulating erythrocytes showed no changes during the day of the experiment. Thereafter the level was almost identical to that of the TMO series without suction. Restoration of preoperative values occurred in three weeks.

In the TMO series plasma hemoglobin showed only minor changes. When controlled suction was instituted, small but significant ($p < 0.001$) differences were seen between the TMO + controlled suction group (24 $\mu\text{mol/l}$) and the MO group without suction

(10 $\mu\text{mol/l}$) at the end of the ECC period. The BO group showed much higher plasma hemoglobin levels of 135 $\mu\text{mol/l}$. Similar differences between the three groups were observed at 240 mins. During the days after the experiment all levels decreased and from day two normal concentrations were measured.

6.3. Series X: TMO + controlled suction

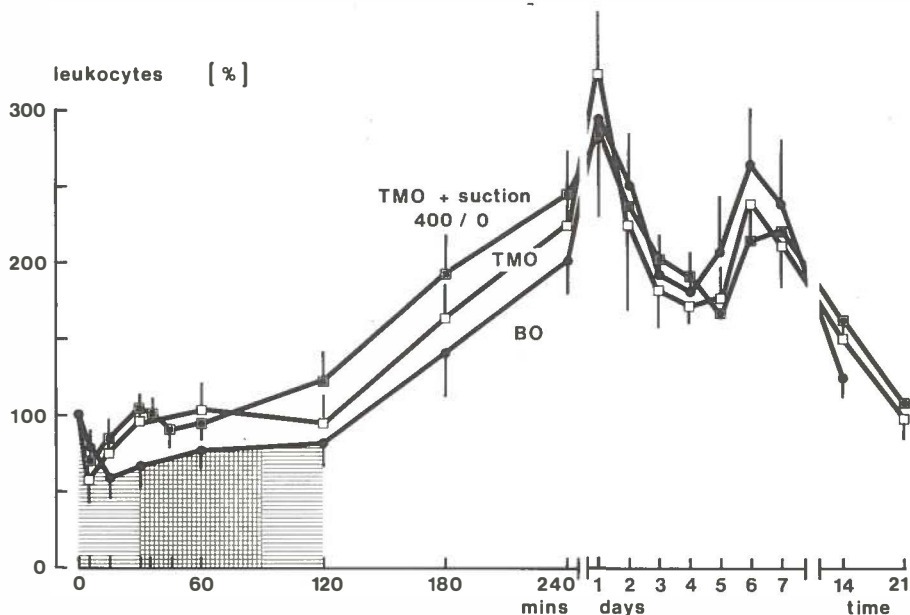

Figure 6.3.6. Percentage of leukocyte number

Throughout the period of three weeks in all three series of experiments identical changes in the number of leukocytes were observed: initial decreases to 60 % at five mins were followed by gradual increases with maximal leukocyte levels of about 300 % on day one, decreases to 180 % on days three to five, renewed increases with maxima of 250 % on day six, and finally gradual normalizations to 100 % after three weeks.

6.4. DISCUSSION

In previous chapters it has been stated that there are several weak links in the chain of the ECC which may be held responsible for the manifold complications experienced in patients after cardiac operations.

Although roller pumps and the nonphysiological materials of the circuit contribute to the damage of the cellular blood elements, only small hematological advantages could be documented in well standardized experiments by using refined pumps and optimally hemocompatible materials (chapters 3 and 4). A definite weak link in the chain of the extracorporeal circuit appeared to be the BO: replacement by a MO yielded substantial improvements in terms of better preserved thrombocytes, almost normal bleeding times and less hemolysis. Clinical evidence for improvements with the use of a MO in cardiopulmonary bypass has also been obtained: the incidence of hemorrhage was greatly reduced and hemolysis was virtually eliminated (chapter 5).

Yet these improvements could not be achieved in comparative studies by other investigators (Lamberti et al., 1976; Sade et al., 1980; Trumbull et al., 1980). Van den Dungen et al. (1982) reported that additional factors were likely to affect the platelets or to cause increased blood loss and need for more blood transfusions. In a study to differentiate the main factors these appeared to be: the type of operation, the perfusion time and the amount of cardiomy suction. They concluded therefore that comparative clinical studies between BOs and MOs should be limited to the same category of patients regarding these three aspects. The importance of the impact of cardiomy suction upon MO perfusion was not only shown experimentally (de Leval et al., 1972; ten Duis, 1982) but also in two clinical studies. Siderys et al. (1975) have demonstrated that the use of an MO did provide superior hematological results in terms of platelet loss and hemolysis when the blood of pericardial suction was discarded. In their study van den Dungen et al. (1982) selected coronary bypass patients in whom suction was mainly limited to apex venting, thus substantially reducing blood to air contact. The study disclosed that differences between BO and MO perfusion were significant with respect to better maintained platelet function and reduced blood loss as well as to decreased blood transfusion requirement after ECC. We have demonstrated in standardized experiments that the vigorous blood to air contact, which is the consequence of high vacuum cardiomy suction, is another weak link in the chain of the extracorporeal circuit. The ex-

periments also clearly show that this cause of cell injury during cardiotomy suction can be excluded by preventing suction of air together with blood in the suction lines by means of the described electronically controlled suction system.

Thrombocyte number and function - When controlled suction is employed the number and function are equally well preserved as in the TMO group without suction. The temporary decreases in number and function which occur immediately after the start of cardiotomy suction must be regarded as a second "initial" dip because a new nonphysiological surface is suddenly exposed to the blood. The lower number of thrombocytes which is measured in the controlled suction and the high vacuum suction series after 180 minutes may reflect a higher degree of blood cell damage following the thoracotomy performed in these series. Another result of the thoracotomy might be the overshoot in thrombocyte numbers to values of 150 % and higher. Thrombocytosis has also been found by other investigators (Davey et al., 1976; van den Dungen et al., 1982).

The delay in the restoration of thrombocyte function in the controlled suction series as compared to the TMO without suction group might be caused by the thoracotomy (McKenzie et al., 1969), but could also be due to the suction procedure. However, the approximately normal bleeding times after ECC indicate that such damage to the platelets is limited and does not affect hemostasis.

When high vacuum suction is applied, both the number and function of thrombocytes are drastically decreased at the onset of suction and follow the typical course of the BO (figures 6.2.2. and 6.2.3.). Most impressive is the complete loss of function in the high vacuum suction experiments. Practically, the potential benefits of a MO are eliminated by the cardiotomy suction. Careful use of vacuum suction might give some improvement, as has been shown (de Jong et al., 1980) by a better maintained thrombocyte function and less severely prolonged bleeding times after the experiment.

Bleeding time - The changes in the bleeding time are consistent with the thrombocyte behaviour in the various groups. On the one hand they clearly show the potential beneficial effects of the use of a MO in conjunction with controlled suction, but on the other hand they demonstrate the deleterious effect of high vacuum cardiotomy suction on hemostasis, which eliminates whatever profit has been gained from a MO.

Hematocrit, erythrocyte number, and plasma hemoglobin - The differences in damage to the erythrocytes observed in the suction groups emphasize the observations made in thrombocytes and bleeding time. The

maximum levels of plasma hemoglobin reached at the end of the perfusion show the same grouping as has been observed for the thrombocyte damage. Several investigators (chapter 5) found equally high values in clinical MO and BO perfusion studies, but in their situation high vacuum suction was invariably combined with MO perfusion. We have shown before (see 5.2.5.) that maximal plasma hemoglobin levels in BO perfusion are 13.5 times the level in MO perfusion. Furthermore the results of our experiments clearly indicate that in the combination of TMO with suction the extensive hemolysis is due to the high vacuum suction procedure, because hemolysis was greatly reduced by employing controlled suction. Wright (1978) performed in vitro experiments from which he concluded that the aspiration of an equal quantity of air along with the suction of blood increased the rate of hemolysis tenfold. The minor though significant differences in level between the TMO and the controlled suction experiments may be due to mesothelial and pericardial surface contact, as well as to an additional damaging effect of the suction circuit. These findings confirm those of Morris et al. (1965) and Siderys et al. (1975), who stated that to a major extent hemolysis is caused by the contact of blood with the pericardium and that bubble oxygenation is less important in this regard.

The changes in erythrocyte numbers are also indicative for erythrocyte damage. During perfusion major changes in the values corrected for hemodilution are not observed. A tendency towards a small increase is seen in the TMO and controlled suction groups, whereas minor decreases are measured in the BO and high vacuum suction groups. As is shown by increased plasma hemoglobin levels in the latter groups, a substantial decrease of erythrocyte numbers can be expected. The normal values indicate that these losses of erythrocytes during perfusion have presumably been compensated by spleen contraction. The postoperative anemia, due to the elimination of erythrocytes damaged during ECC, shows the same order in the various groups as the other parameters do: on day one after perfusion controlled suction is in the range of TMO perfusion, whereas high vacuum suction shows much lower values. Therefore the development of severe anemia in patients after cardiopulmonary bypass is consistent with the reports of erythrocyte damage during experimental ECC.

Leukocyte number - Major differences between the groups are not observed in the courses of leukocyte numbers. Only the few surviving dogs in the high vacuum suction group show a different course of leukocyte number after the experiment. An infectious process (antibiotic prophylaxis was not included in

the protocol) is believed to be responsible for this abnormal pattern, because not only leukocyte number but also body temperature and SRE were markedly elevated in these animals.

These findings confirm reports of high incidences of infection after cardiopulmonary bypass (see 3.5.1.5.). Next to the possibility of impaired cellular defense to infection, there is also a definite risk of airborne contamination during CPB (Blakemore et al., 1971). This was also demonstrated in a prospective study, evaluating a cross flow unit during cardiac surgery (Dankert et al., 1978). It was found that after CPB under the normal conditions of an operating theatre 79 % of the oxygenators were contaminated, whereas only 17 % were infected when the cross flow unit was used. In an experimental setup it was proved by Zijlstra et al. (1978) that cardiotomy suction was the open link to air causing contamination. They stressed that by employing a controlled suction system airborne contamination both of the wound area and of the circulating blood was minimized. Furthermore, reduction of septicemia was obtained in this animal model as a result of the reduced contamination.

The results of our experiments with the controlled suction are in accordance with these reports: only dogs in the high vacuum suction series experienced infection, whereas none of the animals in the other series did.

6.5. CONCLUSIONS

The results of all parameters in these suction experiments accentuate the fact that in today's setup with uncontrolled cardiotomy suction, there is little relevance in using a MO instead of the hematologically more aggressive BO: all benefits gained by using the MO are counteracted by the suction. The hemocompatibility of cardiotomy suction can be improved, as has been demonstrated experimentally by the results in the controlled suction group. Only when this controlled suction system is introduced clinically in the routine cardiac operation can further improvement of hemocompatibility be expected from the use of a MO.

SUMMARY

Extracorporeal circulation (ECC) causes damage to the blood. All systems employed, such as chronic dialysis with an artificial kidney, cardiopulmonary bypass (CPB) with the heart-lung machine or long term respiratory support with the membrane oxygenator, show, apart from their life supporting functions, side effects like hemorrhages, anemia, increased susceptibility to infection, or denaturation of blood proteins. Especially in open heart surgery hematological problems have frequently been reported. The major problem is damage to the thrombocytes which can provoke hemorrhages, even more so since heparin is required to prevent clotting in the extracorporeal circuit. Destruction of erythrocytes, resulting in anemia and elevated plasma hemoglobin levels, is also regularly observed. Recently the attention is also focussed on impairment of the leukocytes and plasma proteins, which may result in an increased incidence of infection. Activation of complement factor C5a induces leukocyte aggregation, which, in turn, plugs the capillaries in the lung to cause organ dysfunction.

In this thesis the components of the heart-lung machine for CPB operations have been tested for their effects on blood elements. The purpose of the experimental investigation in dogs is:

1. To determine the hematological alterations induced by the various components from which an extracorporeal circuit for CPB is composed (circuit materials, blood pumps, oxygenators and cardiotomy suction devices) in concentrations and functions of blood cells and in fibrin formation.
2. To compose an optimal extracorporeal circuit for cardiac surgery by putting together the least traumatic components and to prove its hematological superiority.

The outline of this thesis is as follows:

Chapter 1 gives the introduction to the subject.

Chapter 2 provides an extensive description of the materials and methods used in this investigation.

Chapter 3 describes the hematological alterations caused by a simple extracorporeal circuit consisting of only tubing and pumps to demonstrate the general behaviour of blood components when exposed to an ECC. In this chapter three different tubing materials will also be compared.

Chapter 4 describes the hematological alterations caused by three different blood pumps. The results of

chapters 3 and 4 together indicate an optimal circuit.

Chapter 5 describes the hematological alterations caused by different oxygenators (one bubble oxygenator and two membrane oxygenators) in standard circuits and in the optimal circuit. The results of chapters 3, 4 and 5 together indicate a hematologically optimal heart-lung machine.

Chapter 6 describes the hematological alterations caused by two different methods of cardiotomy suction: suction of blood with and without air from the thoracic cavity. The results of chapters 3, 4, 5 and 6 together indicate the optimal equipment for cardiac surgical procedures.

Chapter 2:

Experimental setup: mongrel dogs of about 30 kgs were cannulated and connected to a standardized extracorporeal circuit consisting of tubing, blood-pump and heat exchanger. The blood flow rate was maintained at 3 l/min for an ECC period of 2 hours and total heparinization was employed. The circuit was primed with equivalent quantities of heparinized donor blood and gelatin solution. Blood samples were taken from a catheter in the femoral artery to assess to following parameters: numbers of thrombocytes, leukocytes and erythrocytes; ADP induced aggregation of the thrombocytes; bleeding time; hematocrit and plasma hemoglobin. During the experiments with a relatively simple circuit (chapter 3) also hemoglobin, SRE, rectal body temperature, and fibrin formation (APTT, PT, RT, TT) were measured. Blood samples were taken at frequent intervals during the day of the experiment and daily in the recovery period during the first week, on day 14, and on day 21. The series consisted of six experiments. In order to minimize the thrombocyte manipulation, necessary to express platelet function in relation to its number, a nomogram was created. This thrombocyte number versus function nomogram made it possible to compare aggregation curves from samples with different thrombocyte concentrations.

Chapters 3 and 4:

To demonstrate the general behaviour of the blood elements when exposed to an ECC a description is given of the changes caused by a relatively simple extracorporeal circuit consisting of PVC tubing and a roller pump. Thrombocyte numbers show an immediate and sharp drop after starting ECC, probably due to acute intravascular aggregation induced by released bioamines. This reversible process instituted stable levels after 30 minutes for the remaining period of ECC. After disconnection and consequent interruption

of the equilibrium between aggregation and disaggregation, elimination of affected thrombocytes occurs and a secondary dip in numbers can be noticed, usually on day one after the experiment. Then a normal pattern of recovery is observed, which takes place in about one week.

Thrombocyte function, as expressed by the maximal optical density loss (ODmax) and corrected according to the nomogram, shows patterns of impairment comparable to those of the number of thrombocytes.

The clinically relevant parameter of the bleeding time, which is influenced by thrombocyte number and function and, to a less extent, by fibrin formation, shows slightly prolonged values at the end of the day of the experiment, but one day later normal values are found. In this regard the role of fibrin formation is only additional.

During the experiment the number of circulating erythrocytes after correction for differences in hematocrit does not change. Yet, erythrocytes are sublethally damaged by the procedure of ECC as can be concluded from the substantial elimination after ECC. This decrease in number causes anemia lasting for a period of over one week. The increased level of plasma hemoglobin shows that a few erythrocytes are already hemolyzed during the ECC period because of repetitive contact with high shear stresses. After disconnection the level of plasma hemoglobin is not reliable as a quantitative measure because of the complex elimination processes. Hematocrit and hemoglobin level provide the same information as the number of erythrocytes but are also influenced by the procedures of hemodilution (priming solutions, infusions etc.).

Leukocytes respond to the ECC with an initial dip, rapidly followed by a leukocytosis to about three times the baseline value. This increase within one day, which also compensates for leukocyte destruction during ECC, is explained by release of leukocytes from the marginated pool into the circulation. When this reservoir is depleted, a decrease in numbers occurs before a second increase is induced caused by formation of new cells in the bone marrow. Preoperative values are found after two to three weeks. Most probably neutrophilic leukocyte function tests are more indicative for the damage to the leukocytes than numbers alone.

This basic extracorporeal circuit consisting of tubing and blood pump does not provide spectacular damage. Still, the circuit does contribute to the overall damage caused by the heart-lung machine. Therefore it is of importance to incorporate the least traumatic tubing and blood pump available. Comparison of several tubing systems under standardized

conditions has revealed that silica free silicone rubber (SFSR) material is to be preferred to silica filled silicone rubber (SR) or PVC tubing. The slowly moving rotor blood pump also shows less traumatic results than the conventional roller pump or the centrifugal pump. The optimal circuit therefore consists of the rotor pump with silica free silicone rubber tubing.

Chapter 5:

The incorporation of an oxygenator yields more important differences than those measured between circuits. The use of conventional bubble oxygenators (BO) results in extensive destruction: low number of thrombocytes, disappearance of function and disturbed fibrin formation provoke a severely increased bleeding time, only normalizing after one week. A high level of plasma hemoglobin and severe anemia after the experiment show the damaging effect on the red cells. Leukocytes are also strongly affected. The anemia and the leukocyte disturbance last three weeks. The interconnection of a membrane oxygenator (MO) instead of the BO results in important improvements: the thrombocytes are significantly less injured and the resulting bleeding time is only slightly prolonged for a period of one day. The level of plasma hemoglobin is minimally increased and the anemia after the experiment is much less pronounced. Important differences are not observed between MO and BO with regard to the number of leukocytes.

As the MO is available in various materials and designs, a comparative study was performed between the microporous Teflo Modulung MO (TMO) and the silica free silicone rubber Kolobow MO. The thrombocyte number was better maintained with the TMO, but thrombocyte function, erythrocyte damage and leukocyte behaviour did not show differences. We have demonstrated that the combination of a TMO with silica free silicone rubber tubing and a rotor blood pump provides optimal hemocompatibility.

Chapter 6:

The hematologically crucial element in the circuit for CPB is the cardiotomy suction. The conventional suction system, in which blood is aspirated together with large amounts of air, act as true bubble oxygenator. This common system of blood with air suction has been evaluated as high vacuum suction (blood : air = 400:1000 ml/min). The results of these experiments are similar to those obtained in the BO experiments: all cellular elements are equally strongly affected and the bleeding time is severely prolonged for a week. To avoid this blood to air contact a suction system was developed in which a detector

connected to an electronic circuit regulates the pump speed and keeps the level of the blood above the tip of the sucker. Experiments with this controlled suction system have shown results in close relation to those obtained in the TMO experiments: thrombocytes, leukocytes and erythrocytes are all better preserved, while the bleeding time is only slightly prolonged. Replacement of high vacuum suction by controlled cardiotomy suction is therefore essential in open- heart surgery procedures in order to maintain the definite improvements of hemocompatibility obtained by introduction of the MO.

In conclusion:

In this systematic evaluation of the components of the ECC it was possible to assess hematological alterations caused by each single component of the extracorporeal circuit. From this evaluation the most hemocompatible extracorporeal circuit could be composed. This optimal equipment has been transferred from the animal laboratory to the clinical situations in which CPB is requested and has indeed been able to accomplish a decrease in blood damage.

SAMENVATTING

Na de vrij uitvoerige Engelse summary van dit proefschrift is deze Nederlandse samenvatting algemener van opzet. Daarbij is vakjargon zoveel mogelijk vermeden, waardoor verschillende zaken soms te eenvoudig zullen zijn voorgesteld, maar waardoor ook niet medisch geschoolden wellicht het spoor kunnen volgen.

Bloedsomloop buiten het lichaam is schadelijk voor het bloed. Kunstnieren en hart-long machines, bij voorbeeld, hebben enerzijds een levensondersteunende functie, maar kunnen anderzijds ook bijwerkingen vertonen zoals bloedingen, bloedarmoede of een verhoogde gevoeligheid voor infecties. Met name in de open hart chirurgie is er regelmatig sprake van dergelijke complicaties. Het grootste probleem vormt beschadiging van bloedplaatjes met na de operatie bloedingen als gevolg. Maar ook afbraak van rode bloedcellen komt vaak voor, wat kan leiden tot een opeenhoping van afbraakprodukten (hemoglobine) en tot bloedarmoede na de operatie. Tegenwoordig is ook de aandacht gevestigd op aantasting van de functies van de witte bloedcellen en op de afbraak van die eiwitten in het bloedplasma, die de afweer verzorgen, hetgeen infecties kan veroorzaken. De afbraak van deze eiwitten (complementfactoren) veroorzaakt ook samenklontering van de witte bloedcellen in de haarvaten van de long waardoor na de operatie de longfunctie sterk gestoord kan raken.

In dit proefschrift wordt de hart-long machine (HLM), zoals die tijdens open hart operaties wordt gebruikt, bestudeerd om na te gaan waardoor de genoemde bloedbeschadigingen worden veroorzaakt en of deze te voorkomen zijn. Om dit op een systematische en gestandariseerde wijze te kunnen doen is dit onderzoek op proefdieren (honden) uitgevoerd. Het doel hierbij was:

1. Het vaststellen van de veranderingen in het bloed die worden veroorzaakt door de verschillende onderdelen waaruit de HLM is samengesteld, te weten: de materialen, de bloedpompen, de kunstlongen en bloedafzuigapparatuur. De veranderingen in het bloed worden gemeten door bepaling van de aantallen en de functies van de bloedcellen en de vorming van fibrine.

2. Het samenstellen van een optimale HLM door gebruik te maken van de minst schadelijke onderdelen en vervolgens aan te tonen dat een dergelijk systeem beter is wat bloedbeschadiging betreft dan de gebruikelijke HLM.

Het buiten het lichaam doen circuleren van bloed door middel van een slang met een bloedpomp veroorzaakt reeds duidelijk aantoonbare veranderingen in het bloed (zie figuur). Bloedplaatjes vertonen een scherpe daling in aantal direkt nadat een gedeelte van de bloedsomloop buiten het lichaam tot stand komt. Deze daling wordt veroorzaakt door samenklontering van de bloedplaatjes onder invloed van stoffen die uit bloedplaatjes en rode bloedcellen vrijkomen na het eerste contact tussen deze bloedcellen en de lichaamsvreemde materialen en de bloedpomp. De snelle samenklontering van de bloedplaatjes is omkeerbaar en na een half uur is er een evenwicht tot stand gekomen tussen samenklontering en loslaten van de bloedplaatjes. Dit evenwicht houdt stand zolang de bloedsomloop buiten het lichaam voortduurt. Na ontkoppeling gaat het loslaten nog door, maar wordt de samenklontering niet meer geactiveerd, waardoor het aantal bloedplaatjes gaat stijgen. Dat stijgen is echter een tijdelijke zaak omdat veel bloedplaatjes zo zeer zijn uitgeput dat ze versneld uit het lichaam worden verwijderd. Zo zien we een dag na de proef een tweede daling optreden. Door de normale aanmaak gaat het plaatjesaantal daarna stijgen tot het oorspronkelijke niveau na ongeveer een week weer is hersteld.

De functie van de bloedplaatjes vertoont een patroon van veranderingen dat vergelijkbaar is met het patroon van de aantallen bloedplaatjes. Het aantal en de functie van de bloedplaatjes bepaalt de bloedingstijd. Deze bloedingstijd vertoont daarom een geringe verlenging aan het eind van de dag van de proef, maar een dag later worden al weer normale waarden gevonden.

Het aantal rode bloedcellen verandert niet gedurende de proef. Toch worden de rode bloedcellen beschadigd door het systeem van slang en bloedpomp zoals opgemaakt kan worden uit de aanzienlijke daling van het aantal rode bloedcellen na de proef. Deze daling veroorzaakt bloedarmoede die meer dan een week kan duren. Tevens wordt een verhoogde hoeveelheid hemoglobine in het bloedplasma gemeten tijdens de proef hetgeen aantoont dat de rode bloedcellen ook direkt worden beschadigd gedurende de proef. Dat deze beschadiging niet in een vermindering van het aantal tot uitdrukking komt kan verklaard worden door het vrijkomen van rode bloedcellen uit de milt.

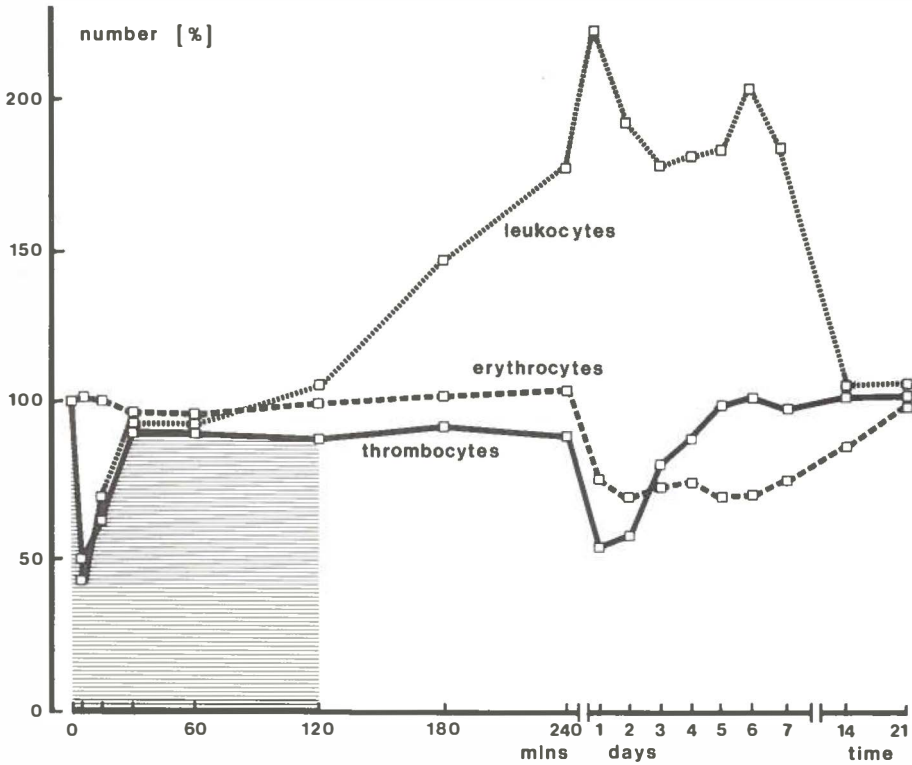

Figuur - Verloop van de aantallen — bloedplaatjes (thrombocytes), ---- rode bloedcellen (erythrocytes), en witte bloedcellen (leukocytes) tijdens en na twee uur stromen door een systeem bestaande uit een slang en een bloedpomp.

Witte bloedcellen reageren op het stromen van het bloed door het systeem van slangen en bloedpomp met een scherpe daling in aantal meteen na aansluiting, en daarna een snelle toename binnen een dag tot ongeveer het drievoudige van het oorspronkelijke aantal. Deze toename kan tot stand komen doordat witte bloedcellen die als voorraad in de bloedvaten tegen de wand aan liggen direkt in de circulatie komen. Zodra deze reserve is uitgeput daalt het aantal witte bloedcellen opnieuw, waarna er een nieuwe stijging optreedt als gevolg van een gestimuleerde nieuwe aanmaak van witte cellen in het beenmerg. Pas na twee tot drie weken is het aantal teruggekeerd tot de oorspronkelijke hoeveelheid. Naar alle waarschijnlijkheid verschaft het meten van de functie van de witte bloedcellen meer gegevens over hun beschadiging dan het louter meten van het aantal.

Hoewel het systeem van slangen en een bloedpomp geen ernstige bloedbeschadigingen laat zien, draagt het zeker bij aan de algehele door de complete HLM veroorzaakte beschadiging. Daarom is het van belang die slangen en die bloedpomp te kiezen die de minste schade veroorzaken. Wanneer verschillende materialen voor slangen en verschillende soorten bloedpompen onder dezelfde omstandigheden worden vergeleken blijkt dat siliconrubber slangen zonder silica vulstof (SFSR) de voorkeur verdienen. Evenzo geeft de rotor bloedpomp, die relatief weinig omwentelingen per minuut maakt, de beste resultaten te zien. Het beste systeem met het oog op de bloedbeschadiging is daarom samengesteld uit SFSR slangen en de rotor bloedpomp.

Het tussenvoegen van een kunstlong laat grotere beschadigingen zien dan zonder kunstlong het geval was. Het gebruik van de bubble oxygenator (BO) leidt tot uitgebreide schade: lage aantallen bloedplaatjes en totale afwezigheid van de functie van de bloedplaatjes aan het einde van de procedure, waardoor een sterke verlenging van de bloedingstijd optreedt die pas na een week weer normaal wordt. Hoge hoeveelheden plasma hemoglobine en ernstige bloedarmoede na de proef tonen het sterk beschadigende effect op de rode bloedcellen aan. Ook de witte bloedcellen nemen duidelijk in aantal af.

Het tussenvoegen van een membraan oxygenator (MO) in plaats van de BO levert belangrijke verbeteringen op: de bloedplaatjes worden aanzienlijk minder aangetast en de bloedingstijd is slechts in lichte mate verlengd na de proef gedurende de periode van een dag. De hoeveelheid plasma hemoglobine neemt slechts weinig toe en de bloedarmoede na de proef is veel minder uitgesproken. Er worden geen duidelijke verschillen tussen de MO en de BO aangetoond met betrekking tot de aantallen witte bloedcellen en dit zou kunnen betekenen dat de activatie van complement factoren beide gelijk is.

Omdat de MO verkrijgbaar is in verschillende ontwerpen en materialen is een vergelijkend onderzoek verricht tussen de microporeuze Teflo Modulung MO (TMO) en de siliconrubber Kolobow MO, wederom zonder silica vulstof (Kolobow MO). Het aantal bloedplaatjes blijft beter op peil met de TMO, maar de functie van de bloedplaatjes, de bloedingstijd, de schade aan de rode bloedcellen of het gedrag van de witte bloedcellen vertonen geen verschillen. Voor de beste resultaten met betrekking tot zo gering mogelijk beschadiging van het bloed is de combinatie van een MO, en bij voorkeur de TMO, met SFSR slangen en de rotor pomp het aangewezen systeem.

Een mede bepalende rol bij het samenstellen van een optimale HLM speelt de bloedafzuigapparatuur, die

tijdens de operatie het bloed verloren in het operatiegebied, weer teruggevoert naar de HLM. Het gebruikelijke bloedafzuigapparaat zuigt het bloed meestal samen met een grote hoeveelheid lucht af en fungeert als een zeer beschadigde BO. De resultaten van proeven waarin dit "slurpen" van het bloed met lucht is verricht komen nauw overeen met de resultaten die verkregen zijn in de proeven met de BO: alle bloedcellen worden evenzeer sterk aangetast en de bloedingstijd is even ernstig verlengd gedurende een week. Om dit "slurpen" van lucht met bloed te voorkomen werd op de TH Eindhoven een zuigapparaat ontwikkeld met een meter aan de tip van de zuiger, die via een elektronisch circuit de snelheid van de zuigpomp regelt zodat het niveau van het bloed altijd boven het uiteinde van de zuiger blijft. Proeven met dit aangepaste zuigsysteem, toegevoegd aan de TMO hebben resultaten opgeleverd die nauw verwant zijn aan de resultaten verkregen met de TMO zonder dat er gezogen wordt: de bloedcellen worden evenzeer beter beschermd en de bloedingstijd is slechts weinig verlengd. Daarom is vervanging van het "slurpende" zuigapparaat door het automatische zuigapparaat van essentieel belang om tijdens operaties met de HLM de zeer duidelijke verbeteringen te handhaven, die zijn verkregen door gebruik te maken van de MO in een optimaal circuit.

Tot besluit:

In dit systematische onderzoek van de onderdelen van de HLM was het mogelijk de veranderingen in het bloed vast te stellen die werden veroorzaakt door elk apart onderdeel. Vanuit dit onderzoek kon die HLM worden samengesteld die het best met het bloed te verenigen is. Deze kennis van de optimale HLM is nu overgebracht naar de klinische omstandigheden waardoor inderdaad een aanzienlijke vermindering van de bloedbeschadiging bij patienten tot stand kon komen.

REFERENCES

Addonizio Jr VP, Colman RW, Edmunds Jr LH: The effect of blood flow rate and circuit surface area on platelet loss during extracorporeal circulation. *Trans Am Soc Artif Intern Organs* 24:650, 1978

Addonizio Jr VP, Strauss III JF, Macarak EJ, Colman RW, Edmunds Jr HE: Preservation of platelet number and function with prostaglandin E₁ during total cardiopulmonary bypass in rhesus monkeys. *Surgery* 83:619, 1978

Addonizio Jr VP, Strauss III JF, Colman RW, Edmunds Jr HE: Effects of prostaglandin E₁ on platelet loss during in vivo and in vitro extracorporeal circulation with a bubble oxygenator. *J Thorac Cardiovasc Surg* 77:119, 1979

Addonizio Jr VP, Smith JB, Strauss III JF, Colman RW, Edmunds Jr HE: Thromboxane synthesis and platelet secretion during cardiopulmonary bypass with bubble oxygenator. *J Thorac Cardiovasc Surg* 79:91, 1980

Addonizio Jr VP, Fisher CA, Bowen JC, Palatianos GC, Colman RW, Edmunds Jr LH: Prostacyclin in lieu of anticoagulation with heparin for extracorporeal circulation. *Trans Am Soc Artif Intern Organs* 27:304, 1981

Akl BF, Vargas GM, Neal J, Robillard J, Kelly P: Clinical experience with the activated clotting time for the control of heparin and protamine therapy during cardiopulmonary bypass. *J Thorac Cardiovasc Surg* 79:97, 1980

Anderson GH, Hellums JD, Moake J, Alfrey Jr CP: Platelet response to shear stress: changes in serotonin uptake, serotonin release, and ADP induced aggregation. *Thromb Res* 13:1039, 1978

Andrade JD, Coleman DL, Didisheim P, Hanson SR, Mason R, Merrill E: Blood-materials interactions - 20 years of frustration. *Trans Am Soc Artif Intern Organs* 27:659, 1981

Arts TH, Spaan JAE, van der Schaar PJ, van Asseldonk AGM, de Maat JACM, van Wely FK: A system for controlled blood suction. *Abstr Trans Am Soc Artif Intern Organs* 5:4, 1976

Bachmann F, McKenna R, Cole ER, Najafi H: The hemostatic mechanism after open-heart surgery; I. Studies on plasma coagulation factors and fibrinolysis in 512 patients after extracorporeal circulation. *J Thorac Cardiovasc Surg* 70:76, 1975

Bartlett RH, Fong SW, Woldanski C, Hung E, Styler D, MacArthur C: Hematologic responses to prolonged extracorporeal circulation (ECC) with microporous membrane devices. *Trans Am Soc Artif Intern Organs* 21:250, 1975

Bartlett RH, Gazzaniga AB, Huxtable RH, Worcester C, Rucker R, Wetmore N, Haiduc N: Extracorporeal membrane oxygenation (ECMO) in newborn respiratory failure: technical consideration. *Trans Am Soc Artif Intern Organs* 25:473, 1979

Beall Jr AC, Solis RT, Kakvan M, Morris Jr GC, Noon GP, DeBaakey ME: Clinical experience with the Teflo disposable membrane oxygenator. *Ann Thorac Surg* 2:144, 1976

Belenger J, Jeanjacquot A, Knight CJ: A seal-less centrifugal pump design for the elimination of heat induced thrombus formation. *Proc Eur Soc Artif Organs* 8:50, 1981

Belenger J, Knight CJ, Jeanjacquot A: Origin of thrombus formation in centrifugal pumps. *Inter J Artif Organs* 5:60, 1982

Bell DM, Goldman DA, Hopkins CC, Karchmer AW, Moellering Jr RC: Unreliability of fever and leukocytosis in the diagnosis of infection after cardiac valve surgery. *J Thorac Cardiovasc Surg* 75:87, 1978

Bell WR, Tomasulo PA, Alving BM, Duffy TP: Thrombocytopenia occurring during the administration of heparin. *Ann Intern Med* 85:155, 1976

Berger S, Salzman EW: Thromboembolic complications of prosthetic devices, *Progress in hemostasis and thrombosis*, TH Spaet ed, New York, 1974, Grune & Stratton, Vol 2

Bernstein EF, DeLaria GA, Johansen KH, Shuman RL, Stasz P, Reich S: Twenty-four hour left ventricular bypass with a centrifugal blood pump. *Ann Surg* 181:412, 1975

Bernstein EF, Blackshear Jr PL, Keller KH: Factors influencing erythrocyte destruction in artificial organs. *Am J Surg* 114:126, 1967

Bernstein EF, Marzec UM: Effect of wall interaction, shear stress and osmotic injury on erythrocyte adenosine triphosphate concentration, 2,3-diphosphoglycerate concentration, and the oxyhemoglobin dissociation curve. *Trans Am Soc Artif Intern Organs* 20:47, 1974

Bernstein EF, Marzec UM, Clayman MD, Swanson S, Johnston GG: Platelet function following surface injury and shear stress: Adhesion, aggregation, release, and factor 3 activity. *Ann NY Acad Sci* 283:138, 1977

Bick RL, Schmalhorst WR, Arbogast NR: Alterations of hemostasis associated with cardiopulmonary bypass. *Thromb Res* 8:285, 1976

Birnbaum D, Thom R, Bücherl ES: The corpuscular volume distribution of erythrocytes during ECMO and after exposure to shear forces, *Artificial organs*, RM Kenedi, JM Courtney, JDS Gaylor, T Gilchrist eds, London, 1977, The MacMillan Press Ltd, p 89

Birnbaum D, Thom R, Billich J, Bücherl ES: Effect of extracorporeal circulation with different oxygenators on the volume of red blood cells, *Basic aspects of blood trauma*, H Schmid-Schönbein, ed, The Hague, Martinus Nijhoff Publ, p 278

Blackshear Jr PL, Dorman FD, Steinbach JH: Some mechanical effects that influence hemolysis. *Trans Am Soc Artif Intern Organs* 11:112, 1965

Blakely JA: Basic techniques of platelet aggregations, *Manual Payton ass*: 8, 1972

Blakemore WS, McGarrity GJ, Thurer RJ, Wallace HW, MacVaugh III H, Coriell LL: Infection by air-borne bacteria with cardiopulmonary bypass. *Surgery* 70:830, 1971

Blombäck M, Noren I, Senning A: Coagulation disturbances during extracorporeal circulation and the postoperative period. *Acta Chir Scand* 127:433, 1964

Bloom S, Zapol W, Wonders T, Berger S, Salzman E: Platelet destruction during 24 hour membrane lung perfusion. *Trans Am Soc Artif Intern Organs* 20:299, 1974

Bloom AL, Thomas DP: *Haemostasis and thrombosis*, Edinburgh, 1981, Churchill Livingstone

Booyse FM, Zschocke D, Hoveke TP, Rafelson Jr ME: Studies on human platelets, IV. Protein synthesis in maturing human platelets. *Thromb Diathes haemorrh* 26:167, 1971

Borchgrevink CF, Waaler BA: The secondary bleeding time, a new method for the differentiation of hemorrhagic diseases. Acta Med Scand 162:361, 1958

Borchgrevink CF, Owren PA: The hemostatic effect of normal platelets in hemophilia and factor V deficiency. Acta Med Scand 170:375, 1961

Born GVR: Aggregation of blood platelets by adenosine diphosphate and its reversal. Nature 194:927, 1962

Born GVR, Cross MJ: The aggregation of blood platelets. J Physiol 168:178, 1963

Born GVR: Effects of unphysiological blood flow on circulating cells, Physiological and clinical aspects of oxygenator design, SG Dawids, HC Engell, eds., Luxembourg, 1976, Elsevier, p 177

Born GVR: Considerations of platelet function mechanism, Basic aspects of blood trauma, H Schmid-Schönbein, ed, Martinus Nijhoff Publ, The Hague, p 23

Brown III CH, Lemuth RF, Hellums JD, Leverett LB, Alfrey CP: Response of human platelets to shear stress. Trans Am Soc Artif Intern Organs 21:35, 1975

Brubaker LH, Nolph KD: Mechanisms of recovery from neutropenia induced by hemodialysis. Blood 38:623, 1971

Brubaker LH, Jensen D, Johnson C, Nothum R, Nolph K: Kinetics of stagnation-induced neutropenia during hemodialysis. Trans Am Soc Artif Intern Organs 18:305, 1972

Bruck SD: Considerations of species-related hematological differences on the evaluation of biomaterials, Biomater Med Devices Artif Organs, 5:97, 1977

Bull BS, Korpman RA, Huse WM, Briggs BD: Heparin therapy during extracorporeal circulation, I. Problems inherent in existing heparin protocols. J Thorac Cardiovasc Surg 69:674, 1975

Bull BS, Huse WM, Brauer FS, Korpman RA: Heparin therapy during extracorporeal circulation, II. The use of a dose-response curve to individualize heparin and protamine dosage. J Thorac Cardiovasc Surg 69:685, 1975

Charm SE, Wong BL: Shear degradation of fibrinogen in the circulation. Science 170:466, 1970

Chawla AS: In vivo interactions between novel filler free silicone rubber and blood. Biomater Med Devices Artif Organs 6:89, 1978

Chawla AS: Preparation of silicone coated biomaterials using plasma polymerization and their preliminary evaluations. Trans Am Soc Artif Intern Organs 25:287, 1979

Chenoweth DE, Cooper SW, Hugli TE, Stewart RW, Blackstone EH, Kirklin JW: Complement activation during cardiopulmonary bypass. N Eng J Med 304:497, 1981

Clark RE, Beauchamp RA, Magrath RA, Brooks JD, Ferguson TB, Weldon CS: Comparison of bubble and membrane oxygenators in short and long perfusions. J Thorac Cardiovasc Surg 78:655, 1979

Colantuoni G, Hellums JD, Moake JL, Alfrey Jr CP: The response of human platelets to shear stress at short exposure times. Trans Am Soc Artif Intern Organs 23:626, 1977

Craddock PR, Fehr J, Dalmaso AP, Brigham KL, Jacob HS: Hemodialysis leukopenia. J Clin Invest 59:879, 1977

- Craddock PR, Fehr J, Brigham KL, Kronenberg RS, Jacob HS: Complement and leukocyte-mediated pulmonary dysfunction in hemodialysis. *N Eng J Med* 296:769, 1977
- Dankert J, Eijgelaar A: The use of a mobile cross-flow unit in open-heart surgery, A bacteriological evaluation. *Antonie van Leeuwenhoek* 44:247, 1978
- Dankert J, Eijgelaar A, Hofstra H: Bacterial infections and extracorporeal circulation, Proc 3rd ann symp works bloodtrans, CT Smit-Sibinga, CRH Wildevuur, eds, Groningen, 1978
- Davey FR, Parker FB: Delayed hemostatic changes following cardiopulmonary bypass. *Am J Med Sci* 271:171, 1976
- David JL, de Clerck F: Detection of platelet activation in vivo: Significance and limitations of the available tests, 5-Hydroxytryptamine in peripheral reactions, F de Clerck, PM Vanhoutte, eds, New York, 1982, 61
- Deggeller K, van den Dungen JJAM, Dankert J, Marrink J, Halie MR, Karliczek GF, Wildevuur CRH: Susceptibility to infection related to extracorporeal circulation: sources of infection, granulocyte function and immunoglobulins, Basic aspects of blood trauma, H Schmid-Schönbein, ed, The Hague, 1979, Martinus Nijhoff Publ, 365
- Dewanjee MK, Vogel SR, Peterson KA, Lim MF, Kaye MP: Quantitation of platelet lysis, platelet consumption on oxygenator, and stabilization of platelet membrane with prostacyclin and ibuprofen during cardiopulmonary bypass surgery in dogs. *Trans Am Soc Artif Intern Organs* 27:197 1981
- Dewitz TS, Hung TC, Martin RR, McIntire LV: Mechanical trauma in leukocytes. *J Lab Clin Med* 90:728, 1977
- Dewitz TS, Martin RR, Solis RT, Hellums JD, McIntire LV: Microaggregate formation in whole blood exposed to shear stress. *Microvasc Res* 16:263, 1978
- Dewitz TS, McIntire LV, Martin RR, Sybers HD: Enzyme release and morphological changes in leukocytes induced by mechanical trauma. *Blood Cells* 5:499, 1979
- Dorlas, JC: Experimentele ervaringen met een hart-long apparaat volgens Lillehei-DeWall, Thesis, State University Groningen, 1960
- Dorman F, Bernstein EF, Blackshear PL, Sovilj R, Scott DR: Progress in the design of a centrifugal cardiac assist pump with trans-cutaneous energy transmission by magnetic coupling. *Trans Am Soc Artif Intern Organs* 15:441, 1969
- Drinker PA: Progress in membrane oxygenator design. *Anesthesiology* 37:242, 1972
- Ten Duis HJ: Intraoperative autotransfusion, Thesis, State University Groningen, 1982
- Ten Duis HJ, de Jong JCF, van Asseldonk AGM, Smit Sibinga CT, Wildevuur CRH: Improved hemocompatibility in open heart surgery. *Trans Am Soc Artif Intern Organs* 24:656, 1978
- Van den Dungen JJAM, Homan van de Heide JN, Karliczek GF, Wildevuur CRH: Clinical evaluation of blood damage related to cardiopulmonary bypass. *Trans Eur Soc Artif Organs* 5:238, 1978
- Van den Dungen JJAM, Karliczek GF, Brenken U, Homan van der Heide JN, Wildevuur CRH: Clinical study of blood trauma during perfusion with membrane and bubble oxygenators. *J Thorac Cardiovasc Surg* 83:108, 1982

- Van den Dungen JJAM: Platelet preservation during cardiopulmonary bypass, Thesis, State University Groningen, 1983
- Dutton RC, Edmunds Jr LH, Hutchinson JC, Roe BB: Platelet aggregate emboli produced in patients during cardiopulmonary bypass with membrane and bubble oxygenators and blood filters. *J Thorac Cardiovasc Surg* 67:258, 1974
- Editorial Lancet: Brain damage after open-heart surgery. *Lancet* 1:1161, 1982
- Egan EL, Bowie EJW, Kazmier FJ, Gilchrist GS, Woods JW, Owen Jr CA: Effects of surgical operations on certain tests used to diagnose intravascular coagulation and fibrinolysis. *Mayo Clin Proc* 49:658, 1974
- Eichler J, Stephan G: The behaviour of clinical standard values after infusions of plasma substitutes, Modified gelatins as plasma substitutes, Basel, 1969, Karger publ, 536
- Eikma C: On the mechanism of platelet aggregation induced by heparin, protamine and polybrene. *Scand J Haematol* 9:248, 1972
- Ennema JJ, Mook PH, Elstrodt JM, Wildevuur CRH: A new hollow fiber membrane oxygenator with an integral heat exchanger: a hematological evaluation in dogs. *Thorac Cardiovasc Surgeon* 31:359, 1983
- Feissly R, Lüdin H: Microscopie par contrastes de phases, III. Applications a l'hématologie. *Rev Hemat* 4:481, 1949
- Feijen J: Materials and biocompatibility, Proc 3rd ann symp work bloodtrans, CT Smit Sibinga, CRH Wildevuur eds, Groningen, 1978, 83
- Fleming JS, Biol MI, Taylor AR: Current problems and uses of protamine sulphate during cardiopulmonary bypass, *Proc eur Soc Artif Organs* 4:611, 1977
- Fleming JS, Biol MI: The rate of protein denaturation in bubble and membrane oxygenators, *Proc europ Soc Artif Organs* 4:544, 1977
- Fleming JS: Protein denaturation and the effect of heparin during extracorporeal circulation, Basic aspects of blood trauma, H Schmid Schönbein, ed, The Hague, 1979, Martinus Nijhoff Publ, 380
- Fong SW, Burns NE, Williams G, Woldanski C, Gazzaniga AB, Bartlett RH: Changes in coagulation and platelet function during prolonged extracorporeal circulation (ECC) in sheep and man. *Trans Am Soc Artif Intern Organs* 20:239, 1974
- Friedman LI, Liem H, Grabowski EF, Leonard EF, McCord CW: Inconsequentiality of surface properties for initial platelet adhesion. *Trans Am Soc Artif Intern Organs* 16:63, 1970
- Friedman LI, Leonard EF: Platelet adhesion to artificial surfaces: consequences of flow, exposure time, blood condition, and surface nature. *Fed Proc* 30:1641, 1971
- Frojmovic MM: Rheooptical studies of platelet structure and function, *Progress in Hemostasis and Thrombosis*, vol 4, TH Spaet, ed, New York, 1978, Grune & Stratton, 279
- Galletti PM: Laboratory experiences with 24 hour partial heart-lung bypass. *Surg Res* 5:97, 1965
- Galletti PM: Blood interfacial phenomena: an overview. *Fed Proc* 30:1491, 1971

Galletti PM: Membrane oxygenation: an overview, Artificial organs, RM Kenedi, JM Courtney, JDS Gaylor, T Gilchrist, eds, The Macmillan Press London, 1977, 11

Gans H, Lillehei CW, Krivit W: Problems in hemostasis during open-heart surgery, I: On the release of plasminogen activator. *Ann Surg* 154:915, 1961

Gans H, Krivit W: Problems in hemostasis during open-heart surgery, IV: On the changes in the blood clotting mechanism during cardiopulmonary bypass procedures. *Ann Surg* 155:353, 1962

Gattinoni L, Pesenti A, Rossi GP, Vesconi S, Fox U, Kolobow T, Agostini A, Pelizzola A, Langer M, Uziel L, Longoni F, Damia G: Treatment of acute respiratory failure with low-frequency positive-pressure ventilation and extracorporeal removal of CO₂. *Lancet* 2:292, 1980

Gattinoni L, Pelizzola A, Caspani ML, Iapichino G, Agostini A, Damia G, Kolobow T: Reversal of terminal acute respiratory failure by low frequency positive pressure ventilation with extracorporeal removal of CO₂ (LFPPV-ECCO₂R). *Trans Am Soc Artif Intern Organs* 27:289, 1981

Glover CJ, McIntire LV, Leverett LB, Hellums JD, Brown CH, Natelson EA: Effect of shear stress on clot structure formation. *Trans Am Soc Artif Intern Organs* 20:463, 1974

Goldman BS, Joison J, Austen WG: Cardiovascular effects of protamine sulfate. *Ann Thorac Surg* 7:459, 1969

Gomes MMR, McGoon DC: Bleeding patterns after open-heart surgery. *J Thorac Cardiovasc Surg* 60:87, 1970

Goodman JS, Schaffner W, Collins HA, Battersby EJ, Koenig MG: Infection after cardiovascular surgery. *N Eng J Med* 278:117, 1968

Van Gool J: Acute-fase-eiwitten; betekenis voor de onstekings-reaktie. *Ned Tijdschr Geneesk* 124:869, 1980
Goslinga H: The viscosity of blood, Thesis, State University Utrecht, 1982

Gott VL: Extracorporeal circulation: 1970-1982. *Trans Am Soc Artif Intern Organs* 28:17, 1982

Grabowski EF, Herther KK, Didisheim P: Human vs dog platelet adhesion to Cuprophane under controlled conditions of whole blood flow. *J Lab Clin Med* 88:368, 1976

Grabowski EF, Didisheim P, Lewis JC, Franta JT, Stropp JO: Platelet adhesion to foreign surfaces under controlled conditions of whole blood flow: human vs rabbit, dog, calf, sheep, pig, macaque and baboon. *Trans Am Soc Art Intern Organs* 23:141, 1977

Graham Jr RC: Disorders of polymorphonuclear leukocytes relevant to infection. *Cleve Clin* 42:33, 1975

Gralnick HR, Fischer RD: The hemostatic response to open-heart operations. *J Thorac Cardiovasc Surg* 61:909, 1971

Hakim J, Gougerot-Pocidallo MA, Lecompte Y: Effects of cardiac surgery and cardio-pulmonary bypass on human immune system, Basic aspects of blood trauma, H Schmid-Schönbein, ed, Martinus Nijhoff Publ, The Hague, 1979, 349

Hakim RM, Lowrie EG: Effect of dialyzer reuse on leukopenia, hypoxemia and total hemolytic complement system. *Trans Am Soc Artif Intern Organs* 26:159, 1980

Halie MR, von dem Borne AEGK: Nederlands leerboek der hematologie, Bunge, Utrecht, 1983

Hammer R: Basisinformatie über Haemacel, Plasma vervangingsmiddelen, A Jansz, A van der Kuy eds, Bohn, Scheltema & Holkema, Utrecht, 1976, 23

Hammerschmidt DE, White JG, Craddock PR, Jacob HS: Corticosteroids inhibit complement-induced granulocyte aggregation. J Clin Invest 63:798, 1979

Hammerschmidt DE, Weaver LJ, Hudson LD, Craddock PR, Jacob HS: Association of complement activation and elevated plasma-C5a with adult respiratory distress syndrome. Lancet 1:947, 1980

Hammerschmidt DE, Stroncek BCE, Bowers TK, Lammi-Keefe CJ, Kurth DM, Ozalins A, Nicoloff DM, Lillehei RC, Craddock PR, Jacob HS: Complement activation and neutropenia occurring during cardiopulmonary bypass. J Thorac Cardiovasc Surg 81:370, 1981

Hardeman MR: Platelet preservation, Thesis, University of Amsterdam, 1974

Hardwick RA, Gritsman HN, Stromberg RR, Friedman LI: The biochemical mechanisms of shear-induced platelet aggregation. Trans Am Soc Artif Intern Organs 29:448, 1983

Harker LA, Slichter SJ: The bleeding time as a screening test for evaluation of platelet function. N Eng J Med 287:155, 1972

Hastings WL, Aaron JL, Deneris J, Kessler TR, Pons AB, Razzeca KJ, Olson DB, Kolff WJ: A retrospective study of nine calves surviving five months of the pneumatic total artificial heart. Trans Am Soc Artif Intern Organs 27:71, 1981

Hathaway WE: Bleeding disorders due to platelet dysfunction. Am J Dis Child 121:127, 1971

Hawkey CM: The relationship between blood coagulation and thrombosis and atherosclerosis in man, monkeys and carnivores. Thromb Diathes Haem 31:103, 1974

Heiden D, Mielke Jr CH, Rodvien R, Hill JD: Platelets, hemostasis and thromboembolism during treatment of acute respiratory insufficiency with extracorporeal membrane oxygenation. J Thorac Cardiovasc Surg 70:644, 1975

Heiden D, Mielke Jr CH, Rodvien R: Impairment by heparin of primary haemostasis and platelets (14C)5-Hydroxytryptamine release. Br J Haematol 36:427, 1977

Heimbecker RO: Progress in extracorporeal circulation. J Thorac Cardiovasc Surg 74:157, 1977

Heimbecker RO: Atraumatic perfusion and the membrane lung - a quiet revolution. Eur Surg Res 9:1, 1977

Hellums JD, Brown III CH: Blood cell damage by mechanical forces, Cardiovascular flow dynamics and measurements, NHC Hwang, NA Normann, eds, University Park Press, Baltimore, 1977, 799

Hellums JD, Hardwick RA: Response of platelet to shear stress - a review, The rheology of blood, blood vessels and associated tissues, DR Gross, NHC Hwang, eds, Sijthoff & Noordhoff, Alphen aan den Rijn, 1981, 160

Henderson LW, Miller ME, Hamilton RW, Norman ME: Hemodialysis leukopenia and polymorph random mobility - a possible correlation. J Lab Clin Med 85:191, 1975

- Hershko C, Cook JD, Finch CA: Storage iron kinetics, II. The uptake of hemoglobin iron by hepatic parenchymal cells. *J Lab Clin Med* 80:624, 1972
- Hessel II EA, Johnson DD, Ivey TD, Miller Jr DW: Membrane versus bubble oxygenator for cardiac operations. *J Thorac Cardiovasc Surg* 80:111, 1980
- Hey D, Neuhoef H: Die Beeinflussung der Blutgerinnung und der Blutplättchenfunktion durch Dextran bzw Gelatine, Plasmapvervangingsmiddelen, A Jansz, A van der Kuy, eds, Bohn, Scheltema & Holkema, Utrecht, 1976, 51
- Hill JD, de Leval MR, Mielke Jr CH, Bramson ML, Gerbode F: Clinical prolonged extracorporeal circulation for respiratory insufficiency: hematological effects. *Trans Am soc Artif Intern Organs* 18:546, 1972
- Hill DG, de Lanerolle P, Kosek JC, Aguilar MJ, Hill JD: The pulmonary pathophysiology of membrane and bubble oxygenators. *Trans Am Soc Artif Intern Organs* 21:165, 1975
- Hill JD: Membrane oxygenators, an editorial introduction. *Artif Organs* 2:4, 1978
- Homan van der Heide, JN: Intracardiale chirurgie met behulp van een cirrestor, Thesis, State University Groningen, 1960
- Van Hoof A, Chamone DAF, Vermylen J: Platelet aggregation and anaesthesia. *Lancet* 2:373, 1980
- Hope AF, duP Heyns A, Lötter MG, van Reenen OR, de Kock F, Badenhorst PN, Pieters H, Kotze H, Meyer JM, Minnaar PC: Kinetics and sites of sequestration of indium 111-labeled human platelets during cardiopulmonary byass. *J Thorac Cardiovasc Surg* 81:880, 1981
- Hyde III SE, Sadler JH: Red blood cell destruction in hemodialysis. *Trans Am Soc Artif Intern Organs* 15:50, 1969
- Iliçin G, Saylam A, Bozer AY: The effect of extracorporeal circulation on serotonin metabolism. *Ann Thorac Surg* 13:225, 1972
- Indeglia RA, Shea MA, Forstrom R, Bernstein EF: Influence of mechanical factors on erythrocyte sublethal damage. *Trans Am Soc Artif Intern Organs* 14:264, 1968
- McIntire LV, Dewitz TS, Martin RR: Mechanical trauma effects on leukocytes. *Trans Am Soc Artif Intern Organs* 22:444, 1976
- McIntire LV, Stockwell DJ, Martin RR, Sybers HD: Leukocyte response to mechanical trauma - antiplatelet drug effect. *Trans Am Soc Artif Intern Organs* 26:289, 1980
- McIntire LV, Martin RR: Mechanical trauma induced PMN leukocyte dysfunction, The rheology of blood, blood vessels and associated tissues, DR Gross, NHC Hwang, eds, Sijthoff & Noordhoff, Alphen aan den Rijn, 1981, 214
- Jacob AI, Gavellas G, Zarco R, Perez G, Bourgoignie JJ: Leukopenia, hypoxia, and complement function with different hemodialysis membranes. *Kidney Int* 18:505, 1980
- Jacob HS, Craddock PR, Hammerschmidt DE, Moldow CF: Complement-induced granulocyte aggregation. *N eng J Med* 302:789, 1980
- Johnston GG, Hammill FS, Johansen KH, Marzec U, Gerard D, Dilley RB, Bernstein EF: Prolonged pulsatile and nonpulsatile LV bypass with a centrifugal pump. *Trans Am Soc Artif Intern Organs* 22:323, 1976

De Jong JCF, ten Duis HJ, Smit Sibinga CT, Wildevuur CRH: Hematological damage by blood/air interfaces in openheart surgery. Proc Eur Soc Artif Organs 4:532, 1977

De Jong JCF, Smit Sibinga CT, Wildevuur CRH: Platelet behaviour in extracorporeal circulation, Artif organs, RM Kenedi, JM Courtney, JDS Gaylor, T Gilchrist, eds, MacMillan Press, London, 1977, 27

De Jong JCF, Woltjes J, Paping RHL, Wildevuur CRH: Impaired leucocyte function and postoperative infection in extracorporeal circulation (ECC). Proc Eur Soc Artif Organs 4:523, 1977

De Jong JCF, Smit Sibinga CT, Wildevuur CRH: Platelet behaviour in extracorporeal circulation (ECC). Transfusion 19:72, 1979

De Jong JCF, ten Duis HJ, Smit Sibinga CT, Wildevuur CRH: Hematologic aspects of cardiotomy suction in cardiac operations. J Thorac Cardiovasc Surg 79:227, 1980

Joyce LD, de Vries WC, Hastings WL, Olsen DB, Jarvik RK, Kolff WJ: Response of the human body to the first permanent implant of the Jarvik-7 total artificial heart. Trans Am Soc Artif Intern Organs 29:81, 1983

Kalter RD, Saul CM, Wetstein L, Soriano C, Reiss RF: Cardiopulmonary bypass, associated hemostatic abnormalities. J Throac Cardiovasc Surg 77:427, 1979

Van Kampen EJ, Zijlstra WG: Standardization of hemoglobino-
metry, II. The hemiglobincyanide method. Clin Chim Acta 6:538, 1961

Kaplan KL, Owen J: Plasma levels of beta-thromboglobulin and platelet factor 4 as indices of platelet activation in vivo. Blood 57:199, 1981

Kaplow LS, Goffinet JA: Profound neutropenia during the early phase of hemodialysis. JAMA 203:133, 1968

Karpatkin S, Charnatz A: Heterogeneity of human platelets, I. Metabolic and kinetic evidence suggestive of young and old platelets. J Clin Invest 48:1073, 1969

Karpatkin S: Heterogeneity of human platelets, II. Functional evidence suggestive of young and old platelets. J Clin Invest 48:1083, 1969

Kayser KL: Blood-gas interface oxygenators versus membrane oxygenators. Ann Thorac Surg 17:459, 1974

McKenna R, Bachmann F, Whittaker B, Gilson JR, Weinberg Jr M: The hemostatic mechanism after open-heart surgery, II. Frequency of abnormal platelet functions during and after extracorporeal circulation. J Thorac Cardiovasc Surg 70:298, 1975

Kennedy PS, Solis RT, Storey Jr SS, Viancos JG, DeBaKey ME: Cardiopulmonary bypass surgery, Arch Surg 113:1429, 1978

Mc Kenzie FN, Dhall DP, Arfors KE, Nordlund S, Matheson NA: Blood platelet behaviour during and after open-heart surgery. Br Med J 2:795, 1969

Mc Kenzie N, Wall W, Robert A, Barnicoat K, Gergely N, Heimbecker R: Blood-free open-heart surgery, The blood sparing effect of an atraumatic circuit and a membrane oxygenator (abstr). Circulation 51,52: Suppl 2:73, 1975

Van Kessel PH: Aggregatie en levensduur van thrombocyten in de zwangerschap, Thesis, Erasmus University, Rotterdam, 1977

- Kessler J, Patterson Jr RH: The production of microemboli by various blood oxygenators. *Ann Thorac Surg* 9: 221, 1970
- Kim SW: Platelet-protein interactions: role of proteins in platelet aggregation and adhesion, *Artificial organs*, RM Kenedi, JM Courtney, JDS Gaylor, T Gilchrist, eds, The Macmillan Press, London, 1977, 273
- Kim SW, Lee RG, Oster H, Coleman D, Andrade JD, Lentz DJ, Olsen D: Platelet adhesion to polymer surfaces. *Trans Am Soc Artif Intern Organs* 20:449, 1974
- Kolobow T, Zapol W, Pierce J: High survival and minimal blood damage in lambs exposed to long term (1 week) veno-venous pumping with a polyurethane chamber roller pump with and without a membrane blood oxygenator. *Trans Am Soc Artif Intern Organs* 15:172, 1969
- Kolobow T, Stool EW, Weathersby PK, Pierce J, Hayano F, Suandeau J: Superior blood compatibility of silicone rubber free of silica filler in the membrane lung. *Trans Am Soc Artif Intern Organs* 20:269, 1974
- Kolobow T, Tomlinson TA, Pierce JE: Blood compatibility of methyl, methyl vinyl, methyl phenyl, and trifluoropropylmethylvinyl silicone rubber without silica fillers in the spiral-coiled membrane lung. *J Biomed Mater Res* 11:471, 1977
- Kolobow T: The promise of the membrane artificial lung. *Inter J Artif Organs* 1:15, 1978
- Kolobow T, Gattinoni L, Fumagalli R, Arosi P, Pesenti A, Solca M, Chen V: Carbon dioxide and the membrane artificial lung: their roles in the prevention and treatment of respiratory failure. *Trans Am Soc Artif Intern Organs* 28:20, 1982
- Kusserow BK, Clapp JF: Red blood cell survival after prolonged perfusion with a blood pump. *Trans Am Soc Artif Intern Organs* 12:121, 1966
- Kusserow BK, Larrow R: Studies of leukocyte response to prolonged blood pumping - effects upon phagocytic capability and total white cell count. *Trans Am Soc Artif Intern Organs* 14:261, 1968
- Kusserow BK, Larrow R, Nichols J: Metabolic and morphological alterations in leukocytes following prolonged blood pumping. *Trans Am Soc Artif Intern Organs* 15:40, 1969
- Kusserow BK, Larrow R, Nichols J: Perfusion- and surface-induced injury in leukocytes. *Fed Proc* 30:1516, 1971
- Kusserow BK, Larrow R, Nichols J: Decreased reticuloendothelial phagocytic function following prolonged in vivo blood pumping - preliminary observations. *Trans Am Soc Artif Intern Organs* 21:388, 1975
- Lagergren H, Olsson P, Swedenborg J: Inhibited platelet adhesion: A non-thrombogenic characteristic of a heparin-coated surface. *Surgery* 75:643, 1974
- Lagergren H: What has been done with regard of blood compatibility ?, *Physiological and clinical aspects of oxygenator design*, SG Dawids, HC Engell, eds, Elsevier North-Holland, 1976, 299
- Lambert J: Mechanical red cell disruption, *Basic aspects of blood trauma*, H Schmid Schönbein, ed, Martinus Nijhoff Publ, The Hague, 1979, 300

Lamberti J, Lin CY, Replogle R, Anagnostopoulos CE: An examination of the use of membrane oxygenators for routine open-heart surgery. *Eur Surg Res* 8, suppl 1:98, 1976

Laufer N, Merin G, Grover NB, Pessachowicz B, Borman JB: The influence of cardiopulmonary bypass on the size of human platelets. *J Thorac Cardiovasc Surg* 70:727, 1975

Leclerc M, Kodabandeh A: Microméthode de dosage du fibrinogène plasmatique. *Ann Biol Clin* 11:596, 1953

Lee Jr WH, Krumhaar D, Fonkalsrud EW, Schjide OA, Maloney Jr JV: Denaturation of plasma proteins as a cause of morbidity and death after intracardiac operations. *Surgery* 50:29, 1961

Lee Jr WH, Hairston P: Structural effects on blood proteins at the gas-blood interface. *Fed Proc* 30:1615, 1971

Lee Kum-Tatt, Ai-Mee Ling: Determination of microquantities of haemoglobin in serum, *Mikrochim Acta* 5:995, 1969

Leichtman DA, Friedman BA: The hemorrhagic complications of open heart surgery. *Crit Rev Clin Lab Sci* 7:239, 1977

Leininger RI, Crowley JP, Falb RD, Grode GA: Three years' experience in vivo and in vitro with surfaces and devices treated by the heparin complex method. *Trans Am Soc Artif Intern Organs* 18:312, 1972

Leonard F: A rationale for the preparation of nonthrombogenic materials. *Trans Am Soc Artif Intern Organs* 15:15, 1969

De Leval MR, Hill JD, Mielke Jr CH, Bramson ML, Smith C, Gerbode F: Platelet kinetics during extracorporeal circulation. *Trans Am Soc Artif Intern Organs* 18:355, 1972

De Leval MR, Hill JD, Mielke Jr CH: Haematological aspects of extracorporeal circulation, *Techniques in extracorporeal circulation*, MI Ionescu, GH Wooler, eds, Butterworths & Co., Ltd., London, 1975, 371

De Leval MR, Hill JD, Mielke Jr CH, Macur MF, Gerbode F: Blood platelets and extracorporeal circulation, *Kinetic studies on dogs on cardiopulmonary bypass*. *J Thorac Cardiovasc Surg* 69:144, 1975

Leverett LB, Hellums JD, Alfrey CP, Lynch EC: Red blood cell damage by shear stress. *Biophys J* 12:257, 1972

Levine PH: Platelet-function tests: predictive value. *N Eng J Med* 292:1346, 1975

Levine PH: The effect of thrombocytopenia on the determination of platelet aggregation. *Am J Clin Pathol* 65:79, 1976

Lewis JC, Didisheim P, Grabowski EF, Mann KG: Ultrastructural characteristics of dog and human platelets adherent to native and collagen-coupled Cuprophane. *Artif Organs* 3:171, 1979

Liddicoat JE, Bekassy SM, Beall Jr AC, Glaeser DH, DeBakey ME: Membrane vs bubble oxygenator: clinical comparison. *Ann Surg* 181:747, 1975

Lindsay RM: Blood surface interactions. *Trans Am Soc Artif Intern Organs* 26:603, 1980

Lindsay RM: Platelet, foreign surfaces, and heparin, *Physiological and clinical aspects of oxygenator design*, SG Dawids, HC Engell, eds, Elsevier, 1976, 183

Lindsay RM, Friesen M, Cooper J, Birek A, Scott K, Linton AL: Platelet-foreign surface interactions with oxygenator membranes, Artificial organs, RM Kenedi, JM Courtney, JDS Gaylor, T Gilchrist, eds, The Macmillan Press, London, 1977, 248

Lindsay RM: Blood surface interactions. Trans Am Soc Artif Intern Organs 26:603, 1980

Loeliger EA, Souverijn JHM, Helleman PW: Het mechanisme van bezinkingssnelheid van erythrocyten. Ned T Geneesk 121:713, 1977

Loeliger EA, van Veen TM, Souverijn JHM, Helleman PW: De meting en de klinische betekenis van de bezinkingssnelheid der erythrocyten (BSE). Ned Tijdschr Geneesk 121:715, 1977

Lötter MG, Badenhorst PN, duP Heyns A, van Reenen OR, Pieters H, Minnaar PC: Kinetics, distribution, and sites of destruction of canine blood platelets with In-111 oxine. J Nucl Med 21:36, 1980

Lubowitz H, Harris F, Mehrjardi MH, Sutura SP: Shear-induced changes in permeability of human RBC to sodium. Trans Am Soc Artif Intern Organs 20:470, 1974

Ludlam CA: Assessment of platelet function, Haemostasis and thrombosis, AL Bloom, DP Thomas, eds, Churchill Livingstone, Edingburgh, 1981, 775

Ludlam CA, Cash JD: Studies on the liberation of beta-thromboglobulin from human platelets in vitro. Br J Haematol 33:239, 1976

Lymann DJ, Knutson K, McNeill B, Shibatani K: The effects of chemical structure and surface properties of synthetic polymers on the coagulation of blood, IV, The relation between polymer morphology and protein adsorption. Trans Am Soc Artif Intern Organs 21:49, 1975

Madras PN, Ward CA, Johnson WR: Enhanced thromboresistance of surfaces by denucleation. Trans Am Soc Artif Intern Organs 26:153, 1980

Melby Jr EC, Altman NH: Handbook of laboratory animal science, vol III, CRC Press, Cleveland, 1976

Mielke Jr CH, de Leval M, Hill JD, Macur MF, Gerbode F: Drug influence on platelet loss during extracorporeal circulation. J Thoracic Cardiovasc Surg 66:845, 1973

Mockros LF, Doerr DE, Zuckerman L: Coagulopathy induced by extracorporeal shear. Trans Am Soc Artif Intern Organs 25:139, 1979

Monti R: Extracorporeal oxygenators, Quantitative cardiovascular studies, NHC Hwang, DR Gross, DJ Patel, eds, University Park Press, Baltimore, 1979, 593

Moriau M, Masure R, Hurllet A, Debeys C, Chalant C, Ponlot R, Jauman P, Servage-Kestens Y, Ravaux A, Louis A, Goenen M: Haemostasis disorders in open heart surgery with extracorporeal circulation. Vox Sang 32:41, 1977

Morris KN, Kinross FM, Stirling GR: Hemolysis of blood in the pericardium: the major source of plasma hemoglobin during total body perfusion. J Thorac Cardiovasc Surg 49:250, 1962

Muller-Eberhard U: Hemopexin. N Eng J Med 283:1090, 1970

Murawska MB, Walstra KS, Smit JW, Deggeller K, Karliczek GF, Homan van der Heide JN, Wildevuur CRH, Halie MR: Effects of open heart surgery on mononuclear cell population. To be published, 1985

Murphy EA, Francis ME: The estimation of blood platelet survival, II. The multiple hit model. *Thromb Haemostas* 25:53, 1971

Mustard JF, Gilbert JB: Long term effects of intermittent low doses of heparin on platelet economy in man. *Lancet* 1:575, 1965

Newland PE: Extracorporeal membrane oxygenation in the treatment of respiratory failure - a review. *Anaesth Intens Care* 5:99, 1977

Nijkamp FP, Sitsen JMA: Leukotrienes, allergy and inflammation. *Pharm Weekbl Sci Ed* 4:165, 1982

Olijslager J, Feijen J, de Jong JCF, Wildevuur CRH: Cellular blood damage caused by foreign materials: an engineers view of the problem, Basic aspects of blood trauma, H Schmid-Schönbein, ed, Martinus Nijhoff Publ, The Hague, 1979, 220

Olijslager J: The development of test devices for the study of blood material interactions. Thesis, Technical University Twente, 1982

O'Rear EA, McIntire LV, Shah BO, Lynch EC: Use of a rheological technique to evaluate erythrocyte membrane alterations. *J Rheol* 23:721, 1979

Osada H, Duffin J, Ward CA, Nelems JM, Cooper JD: Elimination of gas nuclei from membrane oxygenator surface during priming improves platelet preservation. *Artif Organs* 2 (suppl):121, 1978

Paping R, Webster LR, Stanley TH, Razecca K, Kolff WJ: White blood cell phagocytosis after artificial heart implantation. *Trans Am Soc Artif Intern Organs* 24:578, 1978

Parker-Williams EJ: Platelets in prostheses and pumps. *Clin Haematol* 1:413, 1972

Penington DG, Lee NLY, Roxburgh AE, McGready JR: Platelet density and size: the interpretation of heterogeneity. *Br J Haematol* 34:365, 1976

Penington DG: Thrombopoiesis, Haemostasis and thrombosis, AL Bloom, DP Thomas, eds, Churchill Livingstone, Edingburgh, 1981, 1

Pennington DG, Merjavy JP, Swartz MT, Willman VL: Clinical experience with a centrifugal pump ventricular assist device. *Trans Am Soc Artif Intern Organs* 28:93, 1982

Pierce II EC: Is the blood-gas interface of clinical importance? *Ann Thorac Surg* 17:526, 1974

Pierce II EC: The membrane vs bubble oxygenator controversy. *Ann Thorac Surg* 29-6:497, 1980

Pogliani E, Bucciatti G, Fantasia R, Valenti G: Beta-thromboglobulin and platelet factor 4 levels during hemodialysis. *Proc Eur Soc Artif Organs* 6:143, 1979

Pranger RL, Mook PH, Elstrodt JM, Kessler M, Lübbers DW, Wildevuur CRH: Tissue perfusion (PO₂ histograms) in extracorporeal circulation (ECC) using bubble (BO) or membrane oxygenators (MO). *Proc Eur Soc Artif Organs* 6:218, 1979

Pranger RL, Mook PH, Elstrodt JM, Kessler M, Lübbers DW, Wildevuur CRH: Improved tissue perfusion (PO₂ histograms) in extracorporeal circulation using membrane instead of bubble oxygenators. J Thorac Cardiovasc Surg 79:513, 1980

Proctor RR, Rapaport SL: The partial thromboplastin time with kaolin. Am J Clin Pathol 36:212, 1961

Quick AJ: Hemorrhagic diseases and thrombosis, Lea & Febiger, Philadelphia, 1966, 379

Ramstack JM, Zuckerman L, Mockros LF: Shear-induced activation of platelets. J Biomech 12:113, 1979

McRea JC, Kim SW: Characterization of controlled release of prostaglandin from polymer matrices for thrombus prevention. Trans Am Soc Artif Intern Organs 24:746, 1978

O'Rear EA, McIntire LV, Shah BO, Lynch EC: Use of a rheological technique to evaluate erythrocyte membrane alterations. J Rheol 23:721, 1979

Reed CC, Romagnoli A, Taylor DE, Clark DK: Particulate matter in bubble oxygenators. J Thorac Cardiovasc Surg 68:971, 1974

Robinson Jr WP, Mockros LF, Zuckerman L, Vagher JP: Delineation of pump-induced thrombocytopenic responses. Trans Am Soc Artif Intern Organs 24:561, 1978

Roschke EJ, Harrison EC: Fluid shear stress in prosthetic heart valves. J Biomech 10:299, 1977

Roth JA, Golub SH, Cukingnan RA, Brazier J, Morton DL: Cell mediated immunity is depressed following cardiopulmonary bypass. Ann Thorac Surg 31:350, 1981

Rowell HC, Glynn MF, Mustard JF, Murphy EA: Effect of heparin on platelet economy in dogs. Am J Physiol 213:915, 1967

Sade RM, Bartles DM, Dearing JP, Campbell LJ, Loadholt CB: A prospective randomized study of membrane versus bubble oxygenators in children. Ann Thorac Surg 29:502, 1980

Salzman EW: Blood platelets and extracorporeal circulation. Transfusion 3:274, 1963

Salzman EW: Role of platelets in blood surface interactions. Fed Proc 30:1503, 1971

Salzman EW: Platelets, drugs and prosthetic surfaces, Platelets, drugs and thrombosis, J Hirsh, JF Cade, AS Gallus, E Schönbaum, eds, S Karger, Basel, 1975, 226

Salzman EW, Sobel M: Hemostasis problems in extracorporeal circuits. Proceedings 3rd ann symp worksh bloodtransf, CT Smit Sibinga, CRH Wildevuur, eds, 1978, 23

Sandza JG, Clark RE, Weldon CS, Sutura SP: Subhemolytic trauma of erythrocytes: recognition and sequestration by the spleen as a function of shear. Trans Am Soc Artif Intern Organs 20:457, 1974

Schalm OW, Jain NC, Carroll EJ: Veterinary hematology, Lea & Febiger, Philadelphia, 1975

Schermer S: The blood morphology of laboratory animals, FA Davis Comp, Philadelphia, 1967

Schmid-Schönbein H, Rieger H, Zander R: Microrheology of erythrocytes and platelets: physiological basis and consequences for the design and the operation of extracorporeal circulatory devices, Physiological and clinical aspects of oxygenator design, SG Dawids, HC Engell, eds, Elsevier, 1976, 163

Schmid-Schönbein H, Born GVR, Richardson PD, Rohling-Winkel J, Blasberg P, Cusack N, Wehmeyer A, Jüngling E: ADP release from red cells subjected to high shear stresses, Basic aspects of blood trauma, H. Schmid-Schönbein, P. Teitel, eds, Martinus Nijhoff Publ; The Hague, 1979, 322

Schmid-Schönbein H: Discussion, Basic aspects of blood trauma, H. Schmid-Schönbein, P. Teitel, eds, Martinus Nijhoff Publ, The Hague, 1979, 99

Schmid-Schönbein H, Born GVR, Richardson PD, Cusack N, Rieger H, Forst R, Rohling-Winkel I, Blasberg P, Wehmeyer A: Rheology of thrombotic processes in flow: the interaction of erythrocytes and thrombocytes subjected to high flow forces. *Biorheology* 18:415, 1981

Siderys H, Herod GT, Halbrook H, Pittman JN, Rubush JL, Kasebaker V, Berry Jr GR: A comparison of membrane and bubble oxygenation as used in cardiopulmonary bypass in patients. *J Thorac Cardiovasc Surg* 69:708, 1975

Silva J, Hoeksema H, Fekety FR: Transient defects in phagocytic functions during cardiopulmonary bypass. *J Thorac Cardiovasc Surg* 67:175, 1974

Silvay J, Sujansky E, Schnorrer M, Hrubiskova K, Slezak J, Gabauer I, Styk J: The use of gelatinous priming solution for extracorporeal circulation. *J Thorac Cardiovasc Surg* 55:350, 1968

Silvergleid AJ: Clinical platelet transfusions, Blood, blood components and derivatives in transfusion therapy, Am Ass Blood Banks, 1980

Skubitz KM, Craddock PR: Reversal of hemodialysis granulocytopenia and pulmonary leukostasis. *J Clin Invest* 67:1383, 1981

Slichter SJ: Identification & management of defects in platelet hemostasis in massively transfused patients. *Prog Clin Biol Res* 108:225, 1982

Solis RT, Goldfinger D, Gibbs MB, Zeller JA: Physical characteristics of microaggregates in stored blood. *Transfusion* 14:538, 1974

Solis RT, Wright CB, Gibbs MB, Stevens PM: Quantitative studies of microaggregate formation in vitro and vivo. *Chest* 65 (suppl):44, 1974

Solis RT, Kennedy PS, Beall Jr AC, Noon GP, De Bakey ME: Cardiopulmonary bypass: microembolization and platelet aggregation. *Circulation* 52:103, 1975

Solis RT, Beall Jr AC, Noon GP, De Bakey ME: Platelet aggregation: effects of cardiopulmonary bypass. *Chest* 67:558, 1975

Soria J, Soria C, Yver J, Samama M: Temps de reptilase: étude de la polymérisation de la fibrine en présence de reptilase. *Coagulation* 2:173, 1969

Spurling NW: The hematology of the dog, Comparative clinical hematology, RK Archer, LB Jeffcott, eds, Blackwell Scientific Publ, Oxford, 1977, 365

- Stevenson SF, Williams MC: Shear-induced hemolysis with commercial and glow discharge silicones. *Biomater Med Devices Artif Organs* 5:67, 1977
- Subramanian V, Lande AJ, Gans H, Lowman JT, Lillehei CW: Depression of host-defense mechanism following extracorporeal circulation. *Trans Am Soc Artif Intern Organs* 15:165, 1969
- Swank RL, Hissen W, Bergentz SE: 5-Hydroxytryptamine and aggregation of blood elements after trauma. *Surg Gynecol Obstet* 119:779, 1964
- Swedenborg J, Taylor G, Olsson P: Hemodynamic changes of adenosine diphosphate, adenosine triphosphate, and thrombin in relation to their platelet-aggregating activity. *Scand J Clin Lab Invest* 27:213, 1971
- Tabak C, Eugene J, Stemmer EA: Erythrocyte survival following extracorporeal circulation. *J Thorac Cardiovasc Surg* 81:30, 1981
- Tanzawa H, Mori Y, Harumiya N, Miyama H, Hori M, Ohshima N, Idezuki Y: Preparation and evaluation of a new athrombogenic heparinized hydrophilic polymer for use in cardiovascular system. *Trans Am Soc Artif Intern Organs* 19:188, 1973
- Toomasian JM, Helmer GA, Zeme MI, Oltean JN, Oran AD, Bartlett RH: Control of thrombosis in extracorporeal circulation: variations of anticoagulation. *Trans Am Soc Artif Intern Organs* 29:206, 1983
- Trumbull HR, Howe J, Mottl K, Nicoloff DM: A comparison of the effect of membrane and bubble oxygenators on platelet counts and platelet size in elective cardiac operations. *Ann Thorac Surg* 30: 52, 1980
- Ur A: The blood coagulation curve of some mammals. *Res Vet Sci* 16:204, 1974
- Veenhof CHN: Blood and artificial kidney, Thesis, State University of Amsterdam, 1976
- Velders AJ, van den Dungen JJAM, Westerhof NJW, Wildevuur CRH: Platelet damage by protamine administration: Protection by reducing protamine or by prostacyclin (PGI₂) treatment. *Proc Eur Soc Artif Organs* 6:194, 1979
- Velker JA, McIntire LV, Lynch EC: Alteration of erythrocyte deformability due to shear stress as assessed by Nuclepore filters. *Trans Am Soc Artif Intern Organs* 23:732, 1977
- Vermijlen C, Verstraete M: Antithrombin, V: critical evaluation of its assessment and properties. *Thromb Diath Haemorrh* 5:267, 1961
- Vroman L, Adams AL, Klings M: Interactions among human blood proteins at interfaces. *Fed Proc* 30:1494, 1971
- Ward CA, Ruegsegger B, Stanga D, Zingg W: Reduction in platelet adhesion to biomaterials by removal of gas nuclei. *Trans Am Soc Artif Intern Organs* 20:77, 1974
- Ward CA, Ruegsegger B, Stanga D, Zingg W, Herbert MA: Relation of proteins, platelets, and gas nuclei in adhesion to a synthetic material. *Am J Physiol* 233: H100, 1977
- Warren BA, Philp RB, Inwood MJ: The ultrastructural morphology of air embolism: platelet adhesion to the interface and endothelial damage. *Br J Exp Pathol* 54:163, 1973

Van der Weele, LT: Handleiding voor gebruik van de WESP (Waarlijk Eenvoudig Statistisch Pakket) op de CDC cyber. RC publications 8, State University Groningen, 1977

Weiss HJ: Platelet function tests and their interpretation. J Lab Clin Med 87:909, 1976

Wellmer-Köln HK: Verhalten der Thrombocyten des Hundes im Kreislauf bei Infusionen von kolloidalen Blutersatzmitteln. Langenbecks Arch Chir 322:1194, 1968

Wenzel E, Volmer I, Laux E, Limbach HG, Micrendorf M, Müller M, Saavedra E, Monadjemi H, Thetter O, Morgenstern M, Dhon G, Rietkötter U, Otte B, Harbauer G, Svendsen L, Holzhütter H, Angelkort B: Blood trauma and hypercoagulability produced by extracorporeal circulation, Basic aspects of blood trauma, H Schmid-Schönbein, ed, Martinus Nijhoff Publ, The Hague, 1979, 159

Wessler S, Gitel S: Control of heparin therapy, Progress in hemostasis and thrombosis III, TH Spaet, ed, Grune & Stratton, New York, 1976

Westergren A: Die Senkungsreaktion. Ergeb Inn Med Kinderheilk 26:577, 1924

Weston MJ, Woods HF, Ash G, Bunting S, Moncada S, Vane JR: Prostacyclin as an alternative to heparin for hemodialysis in dogs, Prostacyclin, JR Vane, S Bergström, eds, Raven Press, New York, 1979, 349

Wielogorski JW, Davy TJ, Regan RJ: The influence of surface rugosity on haemolysis occurring in tubing. Biomed Eng 91, 1976

Wildevuur CRH: Towards safer cardiopulmonary bypass, Towards safer cardiac surgery, DB Longmore, ed, MTP press, Ltd, Lancaster, 1980

Wildevuur-van Hamersveld C, de Jong JCF, Halie MR, Smit Sibinga CT, Wildevuur CRH: Hematologic abnormalities in extracorporeal circuits (ECC), Physiological and clinical aspects of oxygenator design, SG Dawids, HC Engell, eds, Elsevier, The Hague, 1976, 197

Williams AR: Hydrodynamic disruption of human erythrocytes near a transversely oscillating wire. Rheol Acta 10:67, 1971

Williams AR: In vivo thrombogenesis, The rheology of blood, blood vessels and associated tissues, DR Gross, NHC Hwang, eds, Sijthoff & Noordhoff, Alphen aan den Rijn, 1981, 93

Williams AR, Morris DR: The internal viscosity of the human erythrocyte may determine its lifespan in vivo. Scand J Haematol 24:57, 1980

Wilson MR, Salvaggio JE: Activation of the alternative pathway of complement: a mechanism in search of diseases. J Allergy Clin Immunol 65:319, 1980

Woltjes J, ten Duis HJ, de Jong JCF, Wildevuur CRH: Phagocytic capacity of neutrophilic leucocytes: standardization and application of a simple technique. Proc Eur Soc Artif Organs 3:89, 1976

Woltjes J, de Jong JCF, ten Duis HJ, Wildevuur CRH: The priming of extracorporeal circuits: the effect on canine blood elements. Transfusion 19:552, 1979

Wonders T, Huttemeier P, Berry D, Schuette A, Kong D, Watkins WD, Zapol WM: Complement depletion prevents pulmonary hypertension and leukopenia in sheep extracorporeal membrane oxygenation. Trans Am Soc Artif Intern Organs 29:210, 1983

Woods JE, Kirklin JW, Owen Jr CA, Thompson Jr JH, Taswell HF: Effect of bypass surgery on coagulation-sensitive clotting factors. Mayo Clin Proc 42:724, 1967

Wright JS, Fisk GC, Torda TA, Stacey RB, Hicks RG: Some advantages of the membrane oxygenator for open-heart surgery. J Thorac Cardiovasc Surg 69:884, 1975

Wright G: The mechanics of cell trauma in cardiotomy suction systems, Proceedings 3rd Ann Symp Worksh Bloodtransf, CT Smit Sibinga, CRH Wildevuur, eds, Groningen, 1978, 219

Wu KK, Hoak IC: A new method for the quantitative detection of platelet aggregates in patients with arterial insufficiency. Lancet 2:924, 1974

Wurzinger LJ, Baldauf W, Tobias E, Mottaghy K: Species differences in platelet aggregation with special reference to heparin as anticoagulant, Basic aspects of blood trauma, H Schmid-Schönbein, ed, Martinus Nijhoff Publ, The Hague, 1979, 80

Yates WG, Schaap RN, Baumann GC: Effects of filler-free silicone rubber on platelets during bovine extracorporeal membrane oxygenation. Trans Am Soc Artif Intern Organs 24:644, 1978

Zahavi J, Price AJ, Kakkar VV: Enhanced platelet release reaction associated with general anaesthesia. Lancet 1:1132, 1980

Zapol WM, Bloom S, Carvalho A, Wonders T, Skoskiewicz M, Schneider R, Snider M: Improved platelet economy using filler free silicone rubber in long term membrane lung perfusion. Trans Am Soc Artif Intern Organs 21:587, 1975

Zijlstra JB, Logher E, Dankert J, van Asseldonk AGM, Wildevuur CRH: Contamination and infection induced by autotransfusion: an experimental study in dogs. Proc Eur Soc Artif Organs 5:222, 1978