

University of Groningen

Density, Viscosity, Solubility, and Diffusivity of N₂O in Aqueous Amino Acid Salt Solutions

Kumar, P. Senthil; Hogendoorn, J.A.; Feron, P.H.M.; Versteeg, G.F.

Published in:
Journal of Chemical & Engineering Data

DOI:
[10.1021/je010043a](https://doi.org/10.1021/je010043a)

IMPORTANT NOTE: You are advised to consult the publisher's version (publisher's PDF) if you wish to cite from it. Please check the document version below.

Document Version
Publisher's PDF, also known as Version of record

Publication date:
2001

[Link to publication in University of Groningen/UMCG research database](#)

Citation for published version (APA):

Kumar, P. S., Hogendoorn, J. A., Feron, P. H. M., & Versteeg, G. F. (2001). Density, Viscosity, Solubility, and Diffusivity of N₂O in Aqueous Amino Acid Salt Solutions. *Journal of Chemical & Engineering Data*, 46(6), 1357-1361. <https://doi.org/10.1021/je010043a>

Copyright

Other than for strictly personal use, it is not permitted to download or to forward/distribute the text or part of it without the consent of the author(s) and/or copyright holder(s), unless the work is under an open content license (like Creative Commons).

The publication may also be distributed here under the terms of Article 25fa of the Dutch Copyright Act, indicated by the "Taverne" license. More information can be found on the University of Groningen website: <https://www.rug.nl/library/open-access/self-archiving-pure/taverne-amendment>.

Take-down policy

If you believe that this document breaches copyright please contact us providing details, and we will remove access to the work immediately and investigate your claim.

Downloaded from the University of Groningen/UMCG research database (Pure): <http://www.rug.nl/research/portal>. For technical reasons the number of authors shown on this cover page is limited to 10 maximum.

Density, Viscosity, Solubility, and Diffusivity of N₂O in Aqueous Amino Acid Salt Solutions

P. Senthil Kumar,[†] J. A. Hogendoorn,[†] P. H. M. Feron,[‡] and G. F. Versteeg^{*,†}

OOIP Group, Faculty of Chemical Technology, University of Twente, P.O. Box. 217, 7500 AE Enschede, The Netherlands, and Department of Chemical Engineering, TNO Environment, Energy and Process Innovation, P.O. Box 342, 7300 AH Apeldoorn, The Netherlands

Solubility and diffusivity of N₂O in aqueous solutions of potassium taurate are reported over a wide range of concentration and temperature. Also, the solubility of N₂O in aqueous potassium glycinate solution is reported at 295 K. The ion specific constants, based on the model of Schumpe,^{5,6} are reported for taurate and glycinate anions. A modified Stokes–Einstein relationship is proposed for the diffusivity of N₂O in aqueous potassium taurate solution in the temperature range 293–308 K.

Introduction

Aqueous solutions of amines are extensively used in the removal of acid gas components such as CO₂ and H₂S from a variety of industrial gas streams.¹ In particular, alkanolamines and blends of alkanolamines are widely used amines in the gas-treating industry. Alkanolamines undergo degradation in oxygen-rich atmosphere, usually encountered in the treatment of flue gases, resulting in very toxic degradation products.² Amino acid salts can be a possible alternative to alkanolamines in certain areas of gas treating, although they are more expensive than alkanolamines. The ionic nature of these salt solutions makes them more stable to oxidative degradation along with certain other desirable properties such as low volatility, higher surface tension, and so forth. Salts of amino acids have been of considerable interest in the development of hybrid solvents, especially as promoters to conventional solvents. Some of the amino acids used commercially are glycine, alanine, and diethyl or dimethyl glycine.¹ Numerous processes based on the use of sterically and nonsterically hindered amino acids have been reported in the recent past.² Amino acids containing a sulfonic acid group have greater stability to degradation and are less corrosive than alkanolamines and amino acids with a carboxylic acid group. Taurine (2-aminoethanesulfonic acid) is one such compound, and its potential for use in gas treating is being explored.

Design of gas–liquid contactors, to be used in acid gas-treating processes, requires information on mass-transfer coefficients, interfacial area, reaction kinetics, and physicochemical properties such as solubility and diffusivity of the relevant gases in the solvents. As the acid gases react with the solvents mentioned above, properties such as diffusivity and solubility need to be estimated by an indirect way, using gases with similar properties. In the case of alkanolamines, N₂O is often used as a nonreacting gas to estimate the physicochemical properties of CO₂ in a reactive liquid.³ Because the aqueous salt solutions of amino acids are ionic in nature, the “N₂O analogy” proposed by Laddha et al.,³ for the estimation of the solubility of CO₂

in aqueous alkanolamine solutions, cannot be simply extended for the present situation. Instead, the experimental data on the solubility of N₂O in amino acid salt solutions can be interpreted using the van Krevelen–Hoftijzer model⁴ or the model of Schumpe.^{5,6} Applying these models to the N₂O solubility data, the ionic specific constants as defined by these models can be estimated. Using these constants, the solubility of CO₂ in amino acid salt solutions can now be reliably estimated for the amino acid salt solution.⁷ Gubbins et al.⁸ suggest that the ratio of the diffusivity of the solute gas in an aqueous electrolyte solution to the diffusivity in water is marginally affected by the species of the diffusant. As the properties of N₂O are very similar to those of CO₂ with regard to configuration, molecular volume, and electronic structure, the diffusivity of N₂O in aqueous amino acid salt solutions can be used to estimate the diffusivity of CO₂ in these solutions.⁷ In the present work, the density, viscosity, solubility, and diffusivity of N₂O in aqueous potassium taurate solutions are reported at various temperatures. Also, the solubility of N₂O in aqueous potassium glycinate solutions at 295 K is reported.

Experimental Section

The potassium salt of a selected amino acid was prepared by neutralizing the amino acid (99.9% purity, Merck), dissolved in deionized, distilled water, with an equimolar quantity of potassium hydroxide (Merck) in a standard flask. The neutralization reaction was carried out with constant cooling. The amino acid dissolved in water exists as a zwitterion, with the amino group completely protonated. The ionic equilibrium of the amino acids exists as follows:



Addition of KOH results in deprotonation of the amino group, corresponding to the second equilibrium. Only the deprotonated amine species can react with the acid gases. The concentration of the deprotonated amine (amino acid salt) was estimated potentiometrically, by titrating with standard HCl solutions. The end point is the isoelectric point of the chosen amino acid. The experimentally determined amine concentrations were accurate to within 0.5%.

* Corresponding author. E-mail: g.f.versteeg@ct.utwente.nl.

[†] University of Twente.

[‡] TNO Environment, Energy and Process Innovation.

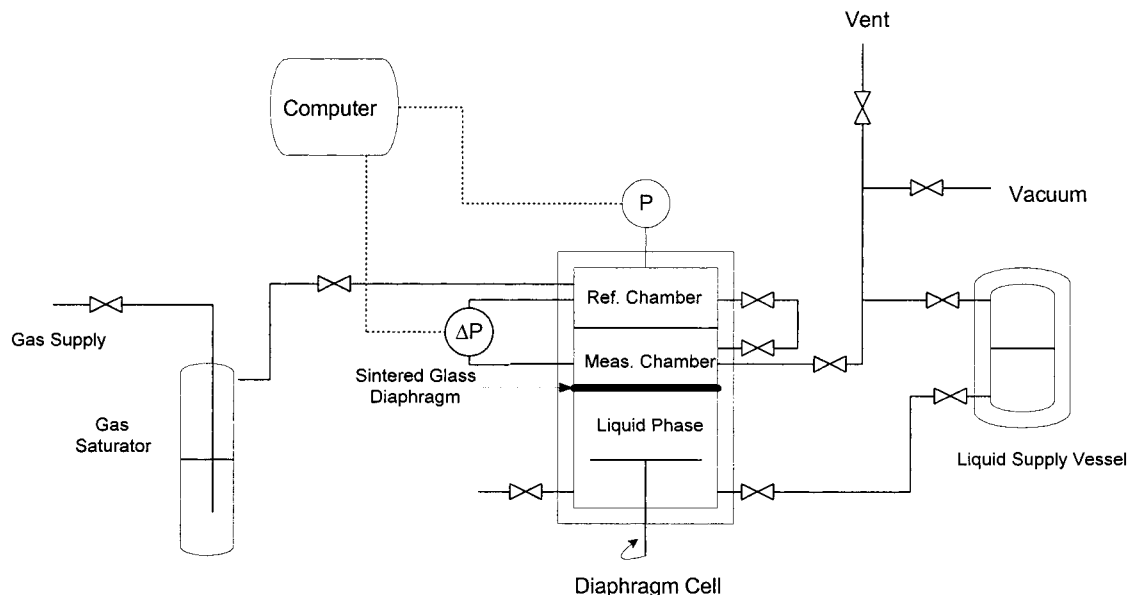

Figure 1. Diaphragm diffusion cell to determine the diffusion coefficient of N_2O in aqueous potassium taurate solutions.

Density and Viscosity. The density was measured using a commercial density meter (DMA 58, Anton Paar GmbH), and the viscosity using a Haake microviscometer (Haake MessTechnik GmbH). In both cases, the measurement temperature could be controlled within ± 0.05 K.

Solubility. The solubility was measured in a thermostatic stirred vessel, provided with a pressure transducer (0–1500 mbar, Druck) and a gas-inducing impeller. A known volume of solution was transferred into the vessel. The temperature of the solution was allowed to adjust to the temperature at which the measurement had to be done. The contents of the vessel above the liquid as well as the dissolved gas in the solution were removed by the application of vacuum, until the gas bubbles ceased to evolve and vapor–liquid equilibrium was attained. The vapor pressure of the liquid was recorded. The gas was fed into the stirred vessel, until a desired pressure was attained and the pressure was recorded. The vessel was closed, and the agitator was turned on. The equilibrium was attained in around 30 min when the pressure inside the vessel remained constant. The final equilibrium pressure value was recorded. From the values of pressures and volumes recorded, the solubility of the gas in the liquid could be calculated. The reliability of the experimental data was verified by measuring the solubility of CO_2 and N_2O in water. The measured values were in agreement with those reported in the literature,⁹ and the accuracy of the experiments was within $\pm 2\%$.

Diffusivity. The diffusion coefficient of N_2O in aqueous potassium taurate solutions was determined using a diaphragm diffusion cell. In the diaphragm cell, a porous, nonpermselective sintered glass membrane separates the liquid and gas phases. The pores of the glass membrane are completely filled with the liquid in which the diffusion coefficient is to be measured (Figure 1). The liquid phase is stirred at sufficiently high speed to avoid mass-transfer resistance in the liquid phase. The liquid inside the pore is stagnant except at very high stirring speeds. If the resistance due to mass transfer in the liquid phase is negligible (at higher stirring speeds) and pure gas is used for absorption, the gas absorption flux through the stagnant liquid film inside the pores of the diaphragm can be related to the diffusion coefficient, using the film theory. From the time versus gas-phase pressure, the diffusion

coefficient can be calculated using overall and gas-phase mass balances as given below.

Overall mass balance:

$$V_G \frac{P_0}{RT} + V_L C_{L,0} = V_G \frac{P(t)}{RT} + V_L C_L(t) \quad (1)$$

Gas-phase balance:

$$\frac{V_G}{RT} \frac{dP}{dt} = -k_L A \left(m \frac{P}{RT} - C_L \right) \quad (2)$$

Initial condition:

$$t = 0; \quad P = P_0; \quad C_L = C_{L,0} = 0 \quad (3)$$

where A is the interfacial area for mass transfer, C_L and $C_{L,0}$ are the concentration of gas in the liquid at time t and at $t = 0$, respectively, k_L is the mass-transfer coefficient, m is the dimensionless solubility defined as the ratio of the liquid-phase concentration to the gas-phase concentration of the solute at equilibrium conditions, $P(t)$ and P_0 are the gas-phase pressures at time t and $t = 0$, respectively, R is the universal gas constant, T is the temperature of the diaphragm cell, and V_G and V_L are the volume of gas and liquid phase, respectively, of the diaphragm cell. The k_L in eq 2 can be defined using the film theory by

$$k_L = \frac{D}{\delta} \quad (4)$$

where D is the diffusion coefficient of gas in the liquid. For the case where the entire mass resistance is located inside the diaphragm, the effective film thickness (δ) depends on the thickness of the membrane (d_m), its porosity (ϵ), and the tortuosity of the pores (τ). Because the values of these properties are not known beforehand, a membrane calibration factor (f) as defined in the equation below has to be determined experimentally

$$k_L A = \frac{D}{d_m} A \frac{\epsilon}{\tau} = Df \quad (5)$$

The calibration factor, f , can be determined by absorbing gas into a liquid, for which the diffusion coefficient is known

accurately. In the present case, the absorption of N₂O and CO₂ in water was used as a calibration system, because, for these systems, a considerable amount of information on diffusion coefficients is available in the literature.⁹

Solving the mass balance equations (eqs 1 and 2) with the initial condition (eq 3), the following equation can be obtained.

$$\ln \left[\frac{(V_G + mV_L) \frac{P(t)}{P_0} - V_G}{mV_L} \right] = -k_L A \left(\frac{1}{V_L} + \frac{m}{V_G} \right) t \quad (6)$$

A plot of eq 6 yields the value of $k_L A$. Using eq 5, the diffusion coefficient can be calculated if the calibration factor, f , is known or vice versa.

Diffusion Cell. The diaphragm diffusion cell used for the measurements is shown in Figure 1. The liquid chamber (volume 282.5 mL) was equipped with a magnetic stirrer. The gas chamber was divided into two parts. The upper chamber (170.5 mL) was the reference chamber and consisted of a pressure transducer (0–1000 mbar, Druck) connected to the lower measuring chamber (187.5 mL) by two valves. The valves can be used to disconnect the two gas chambers. A differential pressure transducer (range 0–0.305 m H₂O; accuracy 1% of full scale; Druck 600DP series) was connected between the reference and measuring chamber. It was used to measure the pressure drop in the measuring chamber, with respect to the constant pressure in the reference chamber. This method of measuring the pressure drop during gas absorption significantly reduces the duration of the experiment, in comparison to that for an earlier version of the instrument containing a gas chamber without a partition.¹⁰ The whole apparatus was thermostated, and the temperature was controlled within ± 0.1 K.

Calibration of Diaphragm. The calibration factor, f , for the diaphragm [P4 type; pore diameter (10–16) μm ; area (33 \pm 0.5) cm²; thickness 4 mm] was determined by carrying out experiments on the absorption of N₂O and CO₂ in water in the temperature range 292–310 K, using different liquid stirrer speeds. The values of diffusion coefficient of N₂O and CO₂ in water obtained from the literature⁹ were used to determine the calibration factor, f . The f factor of the diaphragm used for the measurements was 0.48. The accuracy of the estimated calibration factor was within $\pm 3\%$ for the two gases studied and over the temperature range mentioned above. There was no influence of the stirrer speed between 30 and 60 rpm. At temperatures above 310 K, this operational window reduced and considerable scatter of the estimated f values occurred at the higher and lower ends of the stirrer speed. Therefore, no experiments above 308 K are presented on the diffusivity.

Results and Discussion

The measured values of density and viscosity of the aqueous salt solutions studied are given in Table 1. The estimated accuracy of the density and viscosity measurements is within 0.01% and 0.5%, respectively.

Solubility. Tables 2 and 3 give the experimental data of the solubility of N₂O in aqueous potassium taurate and potassium glycinate solutions, respectively. The data show the typical “salting out effect” observed in electrolyte solutions for N₂O. For moderately high concentrations, the effect can be best described by the Sechenov relation

$$\log(m_w/m) = K C_s \quad (7)$$

Table 1. Density, ρ , and Viscosity, μ , of Aqueous Potassium Taurate Solution

T K	C_s kmol·m ⁻³	$\rho \times 10^{-3}$ kg·m ⁻³	μ mPa·s
293	0	0.9982	0.974
	0.498	1.0375	1.083
	0.996	1.0756	1.217
	1.987	1.1505	1.624
	2.990	1.2240	2.046
303	0.498	1.2966	3.446
	0.996	1.0345	0.925
	1.987	1.0722	1.042
	2.990	1.1463	1.389
	3.979	1.2194	1.729
313	0.498	1.2915	2.652
	0.996	1.0309	0.806
	1.987	1.0683	0.915
	2.990	1.1419	1.204
	3.979	1.2142	1.649
323	0.498	1.2862	2.052
	0.996	1.0274	0.698
	1.987	1.0645	0.788
	2.990	1.1379	1.043
	3.979	1.2102	1.455
328	0.498	1.2817	1.601
	0.996	1.0239	0.636
	1.987	1.0609	0.716
	2.990	1.1242	0.945
	3.979	1.2062	1.332
		1.2775	1.449

Table 2. Solubility, m , of N₂O in Aqueous Potassium Taurate Solutions

C_s kmol·m ⁻³	T K	m mol·mol ⁻¹	C_s kmol·m ⁻³	T K	m mol·mol ⁻¹
0.499	285	0.712	1.479	295	0.452
0.492	295	0.548	1.485	293	0.471
0.492	300	0.498	1.479	299	0.413
0.498	306	0.429	1.488	308	0.339
0.501	308.6	0.398	1.492	313	0.308
0.496	313	0.376	1.492	317	0.281
0.496	314	0.365	2.060	285	0.516
0.499	318	0.333	1.967	293	0.415
0.744	295	0.524	1.972	295	0.389
0.744	300	0.457	1.972	298	0.365
0.741	305	0.418	1.985	308	0.305
0.738	308	0.389	1.985	313	0.279
0.744	313	0.349	1.976	318	0.258
1.001	285	0.675	2.480	285	0.459
1.002	295	0.498	2.992	285	0.401
1.002	300	0.445	2.971	295	0.315
0.998	304	0.406	2.952	298.6	0.290
0.992	308	0.373	2.964	308	0.247
1.005	312.5	0.340	2.986	313.8	0.225
0.999	313	0.334	3.460	285	0.347
0.990	317	0.309	3.985	285	0.275

Table 3. Solubility, m , of N₂O in Aqueous Potassium Glycinate Solutions at 295 K

C_s kmol·m ⁻³	m mol·mol ⁻¹	C_s kmol·m ⁻³	m mol·mol ⁻¹
0	0.605	2.583	0.329
0.507	0.549	2.996	0.285
0.998	0.476	3.505	0.262
1.550	0.432	3.965	0.226
2.006	0.362		

Here m_w and m denote the solubility of N₂O in water and salt solution, respectively, and C_s is the molar salt concentration. Several empirical models have been proposed in the past to predict the Sechenov constant (K). The most widely used models are the van Krevelen–Hoftijzer model⁴ and the one proposed by Schumpe.^{5,6} For a single

Table 4. Sechenov Constants, K , for the Solubility of N_2O in Aqueous Potassium Taurate and Glycinate Solutions

amine salt	T	K	h_+	h_G	h_-
	K	$m^3 \cdot kmol^{-1}$	$m^3 \cdot kmol^{-1}$	$m^3 \cdot kmol^{-1}$	$m^3 \cdot kmol^{-1}$
potassium taurate	285	0.1117	0.0922	-0.0022	0.0239
	295	0.0999	0.0922	-0.0070	0.0217
	300	0.0975	0.0922	-0.0094	0.0241
	308	0.0937	0.0922	-0.0132	0.0279
	313	0.0883	0.0922	-0.0156	0.0273
potassium glycinate	295	0.1058	0.0922	-0.0070	0.0276

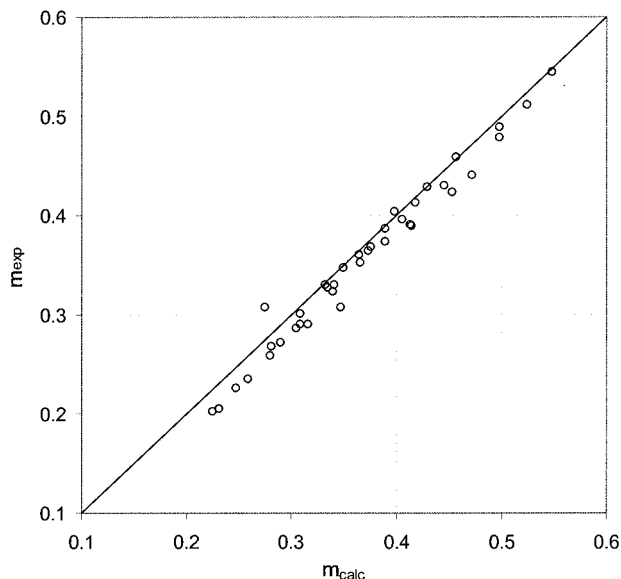
**Figure 2.** Parity plot for the Sechenov model for the N_2O -aqueous potassium taurate system. The average value of h_- (0.0250) was used to estimate the solubility of N_2O .

salt, the Sechenov constant, based on the Schumpe model, is given by the following relation

$$K = \Sigma(h_i + h_G)n_i \quad (8)$$

The Sechenov constant, as defined in the van Krevelen-Hoftijzer model, for a single salt is

$$K = (h_+' + h_-' + h_G')n_i \quad (9)$$

with n_i being the index of the ion i in the formula of the salt. The parameter K is specific to the gas and the salt. h_i and h_G are the ion and gas specific constants. On the basis of extensive study by Schumpe⁶ on the solubility of various gases in different salt solutions, it was found that the standard deviation of the experimentally determined Sechenov constant by the model of Schumpe was half as compared to that of the constant determined with the van Krevelen-Hoftijzer model. So, the model proposed by Schumpe was adopted for the present system.

The plot of eq 7 for the experimental data yields the Sechenov constants, and they are given in Table 4. The experimental data were found to be well fitted by eq 7 ($R^2 > 0.985$). From the Sechenov constants, the anion specific constant (h_-) can be estimated using eq 8 because the information on the cation specific constant (h_+) as well as the gas specific constant (h_G) and its dependence on temperature is available in the literature.⁶ The value of the constant corresponding to the anion is given at various temperatures in Table 4. The average values of h_- for taurate and glycinate ions are 0.0249 (std dev 0.0026) and 0.0276, respectively. A parity plot between the experimen-

Table 5. Diffusivity, D , of N_2O in Aqueous Potassium Taurate Solutions

C_s	T	D		
		$kmol \cdot m^{-3}$	K	$m^2 \cdot s^{-1}$
0.487	293	1.533	1.123	0.934
0.748	293	1.460	1.191	0.890
0.991	293	1.346	1.266	0.820
1.474	293	1.240	1.442	0.756
1.972	293	1.141	1.675	0.695
3.039	293	0.897	2.154	0.547
3.469	293	0.812	2.610	0.495
0.489	296	1.700	1.108	0.967
0.991	296	1.484	1.243	0.844
1.474	296	1.280	1.428	0.728
1.972	296	1.220	1.681	0.694
3.039	296	0.988	2.067	0.562
3.469	296	0.870	2.370	0.495
0.489	299	1.846	1.108	0.981
0.995	299	1.622	1.243	0.862
1.477	299	1.420	1.433	0.755
1.969	299	1.275	1.679	0.678
3.031	299	0.957	2.090	0.509
0.477	305	1.980	1.107	0.922
0.995	305	1.898	1.243	0.884
1.477	305	1.570	1.439	0.731
1.975	305	1.530	1.676	0.713
3.031	305	1.430	2.136	0.666
0.477	308	2.170	1.107	0.948
1.469	308	1.770	1.708	0.774
1.971	308	1.662	1.675	0.726
3.031	308	1.320	2.160	0.577

^a Derived from Table 1.

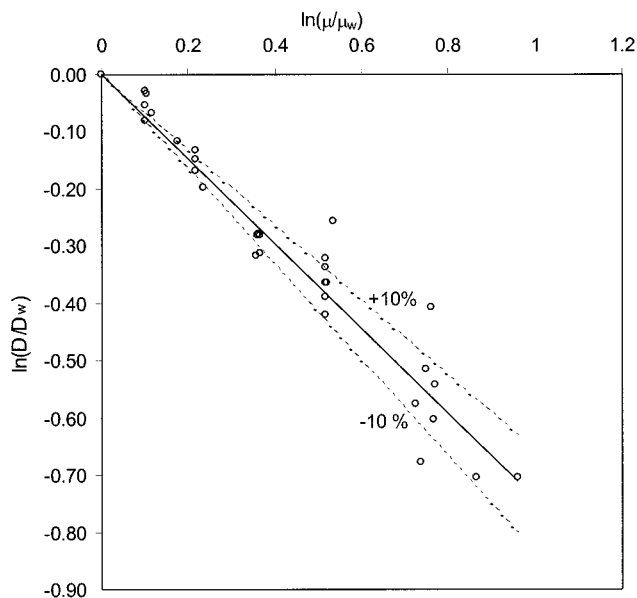
**Figure 3.** Parity plot for eq 10 for the N_2O -aqueous potassium taurate system.

tal data and estimated values using eqs 7 and 8 is shown in Figure 2.

Diffusivity. The experimental data for the diffusivity of N_2O in potassium taurate solutions are given in Table 5. The values provided here are the arithmetic mean of three or four identical measurements. The standard deviation of the measured values was within $\pm 5\%$ of the mean value. The dependence of diffusion coefficient on the concentration and temperature can be described in terms of the viscosity of the solution (μ), using a modified Stokes-Einstein equation. In the case of alkanolamines, the dependence has been reported as $D\mu^{-0.6} = \text{constant}$ for various amines in aqueous solutions.¹¹ Similarly, gas

diffusion in electrolyte solutions can be reasonably correlated with the modified Stokes–Einstein equation.^{8,12} Figure 2 shows the plot of (D/D_w) versus (μ/μ_w) . The data fit to the following equation within $\pm 10\%$ accuracy, as shown in Figure 3.

$$(D/D_w) = (\mu/\mu_w)^{-0.74} \quad (10)$$

Here D_w is the diffusion coefficient of the gas in water and μ_w is the viscosity of water. The values of viscosity used to calculate (μ/μ_w) in Table 5 at various concentrations and temperatures were interpolated from the experimental data given in Table 1.

Conclusions

1. The solubility of N_2O in aqueous potassium glycinate and taurate has been experimentally determined. The effect of temperature and concentration of the salt on the solubility of N_2O can be expressed by the Sechenov equation. The anion specific constant (h_-) in the Sechenov equation has been determined for taurate and glycinate ions.

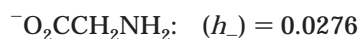
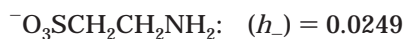

2. The diffusivity of N_2O in potassium taurate solution is reported in the range 0–3.5 M and 293–308 K. As expected, the modified Stokes–Einstein equation can be used for the estimation of the diffusion coefficient of N_2O in aqueous potassium taurate solution.

$$D\mu^{0.74} = \text{constant}$$

Literature Cited

- (1) Kohl, A. L.; Riesenfeld, F. C. *Gas Purification*, 5th ed.; Gulf Publishing Company: Houston, 1995.
- (2) Hook, R. J. An Investigation of Some Sterically Hindered Amines as Potential Carbon Dioxide Scrubbing Compounds. *Ind. Eng. Chem. Res.* **1997**, *36*, 1779–1790.
- (3) Laddha, S. S.; Diaz, J. M.; Danckwerts, P. V. The Analogy: The Solubilities of CO_2 and N_2O in Aqueous Solutions of Organic Compounds. *Chem. Eng. Sci.* **1981**, *36*, 228–229.
- (4) van Krevelen, D. W.; Hoftijzer, P. J. *Chimie et Industrie: Numero Speciale du XXI^e Congress International de Chimie Industrielle*, 1948, Bruxelles, Belgium.
- (5) Schumpe, A. The Estimation of Gas Solubilities in Salt Solutions. *Chem. Eng. Sci.* **1993**, *48*, 153–158.
- (6) Weisenberger, S.; Schumpe, A. Estimation of Gas Solubilities in Salt Solutions at Temperatures from 273K to 363K. *AIChE J.* **1996**, *42*, 298–300.
- (7) Joosten, G. E. H.; Danckwerts, P. V. Solubility and Diffusivity of Nitrous Oxide in Equimolar Potassium Carbonate–Potassium Bicarbonate Solutions at 25 °C and 1 atm. *J. Chem. Eng. Data* **1972**, *17*, 452–454.
- (8) Gubbins, K. E.; Bhatia, K. K.; Walker, R. D., Jr. Diffusion of Gases in Electrolyte Solutions. *AIChE J.* **1966**, *12*, 548–552.
- (9) Versteeg, G. F.; van Swaaij, W. P. M. Solubility and Diffusivity of Acid Gases (CO_2 , N_2O) in Aqueous Alkanolamine Solutions. *J. Chem. Eng. Data* **1988**, *33*, 29–34.
- (10) Littel, R. J.; Versteeg, G. F.; van Swaaij, W. P. M. Solubility and Diffusivity Data for the Absorption of COS , CO_2 and N_2O in Amine Solutions. *J. Chem. Eng. Data* **1992**, *37*, 49–55.
- (11) Snijder, E. D.; te Riele, M. J. M.; Versteeg, G. F.; van Swaaij, W. P. M. Diffusion Coefficients of Several Aqueous Alkanolamine Solutions. *J. Chem. Eng. Data* **1993**, *38*, 475–480.
- (12) Brillman, D. W. F. Mass Transfer and Chemical Reaction in Gas–Liquid–Liquid Systems. Ph.D. Dissertation, University of Twente, Enschede, The Netherlands, 1998.

Received for review February 12, 2001. Accepted June 14, 2001. This research is part of the research programme carried out within the Centre for Separation Technology, a cooperation between the University of Twente and TNO, The Netherlands Organisation for Applied Scientific Research.

JE010043A