

University of Groningen

Adaptive tracking control of fully actuated port-Hamiltonian mechanical systems

Dirksz, D.A.; Scherpen, J.M.A.

Published in:
2010 IEEE INTERNATIONAL CONFERENCE ON CONTROL APPLICATIONS

IMPORTANT NOTE: You are advised to consult the publisher's version (publisher's PDF) if you wish to cite from it. Please check the document version below.

Document Version
Publisher's PDF, also known as Version of record

Publication date:
2010

[Link to publication in University of Groningen/UMCG research database](#)

Citation for published version (APA):

Dirksz, D. A., & Scherpen, J. M. A. (2010). Adaptive tracking control of fully actuated port-Hamiltonian mechanical systems. In *2010 IEEE INTERNATIONAL CONFERENCE ON CONTROL APPLICATIONS* (pp. 1678-1683). (IEEE International Conference on Control Applications). University of Groningen, Research Institute of Technology and Management.

Copyright

Other than for strictly personal use, it is not permitted to download or to forward/distribute the text or part of it without the consent of the author(s) and/or copyright holder(s), unless the work is under an open content license (like Creative Commons).

The publication may also be distributed here under the terms of Article 25fa of the Dutch Copyright Act, indicated by the "Taverne" license. More information can be found on the University of Groningen website: <https://www.rug.nl/library/open-access/self-archiving-pure/taverne-amendment>.

Take-down policy

If you believe that this document breaches copyright please contact us providing details, and we will remove access to the work immediately and investigate your claim.

Downloaded from the University of Groningen/UMCG research database (Pure): <http://www.rug.nl/research/portal>. For technical reasons the number of authors shown on this cover page is limited to 10 maximum.

Adaptive tracking control of fully actuated port-Hamiltonian mechanical systems

D.A. Dirksz and J.M.A. Scherpen

Abstract—In the presence of parameter uncertainty tracking control can result in significant tracking errors. To overcome this problem adaptive control is applied, which estimates and compensates for the errors of the uncertain parameters. A new adaptive tracking control scheme is presented for standard fully actuated port-Hamiltonian mechanical systems. The adaptive control is such that the closed loop error system is still port-Hamiltonian and asymptotically stable.

I. INTRODUCTION

Adaptive control has proved to be a very useful method for control problems where parameter uncertainty influences performance. With adaptive control it is possible to estimate parameter errors and compensate for those errors. This can improve performance of the controlled system. In [10] some adaptive control methods were discussed which explicitly incorporate parameter estimation in the control law. Furthermore, basic adaptive control is described in [14] for linear, nonlinear, single-input and multi-input systems. The recursive methodology of backstepping is described in [8] for nonlinear and adaptive control design. Adaptive control for stabilization and tracking control of Euler-Lagrange (EL) systems was described in [11]. In [12] adaptive control was presented for manipulators with unknown system and friction parameters. The friction forces are determined by a dynamical model, the LuGre friction model. The tracking and disturbance problem for fully actuated mechanical systems was solved in [5]. They assumed that the disturbance signal can be decomposed into a finite superposition of sine waves of arbitrary but known frequencies and an \mathcal{L}_2 -component generated by an exosystem. More recent results in the field of nonlinear applied adaptive control are presented in [1], which rely upon the the notions of *immersion and invariance*.

For adaptive control of port-Hamiltonian (PH) systems little is known. In [2] an adaptive internal model was used to overcome sinusoidal disturbances, but the system parameters were assumed to be known. In [15] simultaneous stabilization of PH systems was investigated. Adaptive control was applied to deal with uncertain parameters. Although the results hold for general time-invariant PH systems, the assumptions limit the class of systems since a restriction is made on the form of the Hamiltonian.

In this paper we present a new adaptive tracking control scheme for standard fully actuated PH mechanical systems. In [4] the tracking problem for these systems was solved by applying the theory of canonical transformation presented in

[3] to stabilize an *error system*. Here we extend the results of [4] to realize adaptive tracking control while preserving the PH structure. The adaptive controller is a direct adaptive controller, i.e., parameter adaptation is driven by the tracking error [13]. The previously mentioned tracking methods which were presented in [5], [10], [11], [12], [13] and [14] have the disadvantage of losing structure: the error system is passive but is not an EL system. They also require a redefinition of the error signal and additional tuning. With the proposed PH adaptive control scheme we still have a PH error system and a redefinition of the error signal is not necessary. Furthermore, the PH structure offers great and insightful possibilities for tuning the adaptive controller.

In the next section we briefly describe the canonical transformation theory for PH systems and the tracking results of [4]. In section III the results of [4] are extended to realize adaptive tracking control. The control strategy is applied on an example in section IV and simulation results are shown. In section V transient performance is briefly analyzed. We conclude with some final remarks in section VI.

II. CANONICAL TRANSFORMATION AND TRACKING CONTROL

Before starting with the adaptive tracking control problem we give a brief summary of canonical transformation theory and how this is applied to realize tracking control. Canonical transformation is widely used for analysis of the structure of dynamical systems in classical mechanics. In [3] canonical transformations for PH systems were introduced. There it was shown how PH systems are stabilized by using the canonical transformation.

Describe a nonautonomous PH system by ¹

$$\begin{aligned} \dot{x} &= (J(x, t) - R(x, t)) \frac{\partial H}{\partial x}(x, t) + g(x, t)u \\ y &= g^\top(x, t) \frac{\partial H}{\partial x}(x, t) \end{aligned} \quad (1)$$

where $x = (x_1, \dots, x_n)^\top$ is the vector of system states, $J(x, t)$ is the skew symmetric interconnection matrix $J(x, t) \in \mathbb{R}^{n \times n}$, $R(x, t)$ a symmetric damping matrix $R(x, t) \in \mathbb{R}^{n \times n}$, $g(x, t)$ the input matrix $g(x, t) \in \mathbb{R}^{n \times l}$, $l \leq n$, u is the control input vector and y the output vector. The Hamiltonian $H(x, t)$ is defined as the sum of kinetic and potential energy of the system. We now present the relevant results of [3], [4].

The authors are with the Faculty of Mathematics and Natural Sciences, University of Groningen, Nijenborgh 4, 9747 AG Groningen, the Netherlands (e-mail: d.a.dirksz@rug.nl, j.m.a.scherpen@rug.nl)

¹All vectors are column vectors, including the gradient of a scalar function

Definition 1: A set of transformations

$$\bar{x} = \Phi(x, t) \quad (2)$$

$$\bar{H} = H(x, t) + U(x, t) \quad (3)$$

$$\bar{y} = y + \alpha(x, t) \quad (4)$$

$$\bar{u} = u + \beta(x, t) \quad (5)$$

that changes the coordinates x into \bar{x} , the Hamiltonian H into \bar{H} , the output y into \bar{y} and the input u into \bar{u} is said to be a generalized canonical transformation for the PH system if it transforms a PH system (1) into another. \triangleleft

The class of generalized canonical transformations are characterized by the following theorem:

Theorem 1: Consider the PH system described by (1). For any scalar function $U(x, t)$ and any vector function $\beta(x, t)$, there exists a pair of functions $\Phi(x, t)$ and $\alpha(x, t)$ that yields a generalized canonical transformation. The function $\Phi(x, t)$ yields a generalized canonical transformation with $U(x, t)$ and $\beta(x, t)$ if and only if there exist $K(x, t) = -K(x, t)^\top$ and $S(x, t) = S(x, t)^\top$ such that $R + S \geq 0$ and the partial differential equation (PDE)

$$\frac{\partial \Phi}{\partial(x, t)} \left((J - R) \frac{\partial U}{\partial x} + (K - S) \frac{\partial(H+U)}{\partial x} + g\beta \right) = 0 \quad (6)$$

holds. The change of output $\alpha(x, t)$ and the matrices $\bar{J}(x, t)$, $\bar{g}(x, t)$ and $\bar{R}(x, t)$ are given by

$$\alpha(x, t) = g^\top(x, t) \frac{\partial U}{\partial x}(x, t) \quad (7)$$

$$\bar{J}(\bar{x}, t) = \frac{\partial \Phi}{\partial \bar{x}} (J + K) \frac{\partial \Phi^\top}{\partial x} \quad (8)$$

$$\bar{g}(\bar{x}, t) = \frac{\partial \Phi}{\partial \bar{x}} g(x, t) \quad (9)$$

$$\bar{R}(\bar{x}, t) = \frac{\partial \Phi}{\partial \bar{x}} (R + S) \frac{\partial \Phi^\top}{\partial x} \quad (10)$$

\triangleleft

Before describing the stabilization theorem the definition of decrescent is given, a concept used for stability analysis of nonautonomous systems.

Definition 2 ([6], [14]): A scalar function $W(x, t)$ is said to be decrescent if $W(0, t) = 0$ and if there exists a time-invariant positive definite function $W_1(x)$ such that

$$\forall t \geq 0, \quad W(x, t) \leq W_1(x) \quad \triangleleft$$

Theorem 2: Consider the PH system described by (1) and transform it by the generalized canonical transformation with $U(x, t)$ and $\beta(x, t)$ such that $H+U \geq 0$. Then the new input-output mapping $\bar{u} \mapsto \bar{y}$ is passive with storage function \bar{H} if and only if

$$\frac{\partial(H+U)^\top}{\partial(x, t)} \left((J - R) \frac{\partial U}{\partial x} - S \frac{\partial(H+U)}{\partial x} + g\beta \right) \geq 0 \quad (11)$$

Suppose that (11) holds, that $H+U$ is positive-definite and that the system is zero-state detectable. Then the feedback $u = -\beta - C(x, t)(y + \alpha)$ with $C(x, t) \geq \epsilon I > 0$ renders the system asymptotically stable. Suppose moreover that

$H+U$ is decrescent and that the transformed system is periodic. Then the feedback renders the system uniformly asymptotically stable. \triangleleft

Describe a standard mechanical system in PH form by

$$\begin{aligned} \begin{bmatrix} \dot{q} \\ \dot{p} \end{bmatrix} &= \begin{bmatrix} 0 & I \\ -I & -D(q, p) \end{bmatrix} \begin{bmatrix} \frac{\partial H}{\partial q} \\ \frac{\partial H}{\partial p} \end{bmatrix} + \begin{bmatrix} 0 \\ G \end{bmatrix} u \\ y &= G^\top \frac{\partial H}{\partial p} \end{aligned} \quad (12)$$

with $q = (q_1, \dots, q_k)^\top$ the vector of generalized configuration coordinates, $p = (p_1, \dots, p_k)^\top$ the vector of generalized momenta, I the identity matrix, $D(q, p) \in \mathbb{R}^{k \times k}$ the (positive definite) damping matrix, G the input matrix and y the output vector. The Hamiltonian of the system is equal to the sum of kinetic and potential energy:

$$H(q, p) = \frac{1}{2} p^\top M^{-1}(q) p + V(q) \quad (13)$$

where $M(q) = M^\top(q) > 0$ is the system mass matrix and $V(q)$ the potential energy. For fully actuated systems the input matrix can be taken (for simplicity) equal to the identity matrix, $G = I$. In [4] canonical transformation is applied with the coordinate transformation $(\bar{q}, \bar{p})^\top = \Phi(q, p, t)$:

$$\bar{q} = q - q_d(t) \quad (14)$$

$$\bar{p} = p - M(q) \dot{q}_d(t) \quad (15)$$

where $q_d(t)$ is the desired trajectory which is assumed to be known and twice differentiable. The solution for β in [4] which realizes a passive PH error system results in the tracking control input

$$\begin{aligned} u &= M(q) \ddot{q}_d - \left(\frac{1}{2} \frac{\partial(M(q) \dot{q}_d)}{\partial q} \right)^\top - \frac{1}{2} \frac{\partial(M(q) \dot{q}_d)}{\partial q} \\ &+ \frac{1}{2} M(q) \frac{\partial(M^{-1}(q) p)}{\partial q} - D \dot{q}_d \\ &+ \rho(q) - \frac{\partial \bar{U}}{\partial q} + \bar{u} \end{aligned} \quad (16)$$

with $\rho(q) = \frac{\partial V}{\partial q}$ and \bar{U} a positive definite function which realizes a unique equilibrium in $\bar{q} = 0$. This realizes the PH error system

$$\begin{aligned} \begin{bmatrix} \dot{\bar{q}} \\ \dot{\bar{p}} \end{bmatrix} &= \begin{bmatrix} 0 & I \\ -I & \bar{J}_2 - \bar{D} \end{bmatrix} \begin{bmatrix} \frac{\partial \bar{H}}{\partial \bar{q}} \\ \frac{\partial \bar{H}}{\partial \bar{p}} \end{bmatrix} + \begin{bmatrix} 0 \\ \bar{G} \end{bmatrix} \bar{u} \\ \bar{y} &= \bar{G}^\top \frac{\partial \bar{H}}{\partial \bar{p}} \end{aligned} \quad (17)$$

with \bar{J}_2 a skew-symmetric matrix, \bar{D} the damping matrix, \bar{G} the input matrix and \bar{u} the input of the error system. From (8)-(10) we have $\bar{D} = D$, $\bar{G} = G$ and

$$\bar{J}_2 = \frac{\partial(M(q) \dot{q}_d)}{\partial q}^\top - \frac{\partial(M(q) \dot{q}_d)}{\partial q} \quad (18)$$

where $(q, p)^\top = \Phi^{-1}(\bar{q}, \bar{p})$. Take

$$\bar{U} = \frac{1}{2} \bar{q}^\top K_p \bar{q} \quad (19)$$

with K_p a positive definite matrix. The positive definite function \bar{U} ensures that the error system is zero-state detectable. The Hamiltonian of the error system (17) becomes

$$\bar{H} = \frac{1}{2}\bar{p}^\top M^{-1}(q)\bar{p} + \frac{1}{2}\bar{q}^\top K_p\bar{q} \quad (20)$$

In [4] it is shown that the the feedback

$$\bar{u} = -K_d\bar{y} \quad (21)$$

with K_d a constant positive definite matrix asymptotically stabilizes the error system. Tracking of desired trajectories is then realized.

In the next section it will be shown that not exactly knowing parameter values result in a passive error system with an additional input. This input is caused by the errors in the parameter values and explains why the tracking error does not converge to zero. Since we need exact knowledge of parameter values to realize convergence of the tracking error we propose to apply adaptive control, which estimates and compensates for errors in parameter values based on the tracking error.

III. ADAPTIVE TRACKING CONTROL

In the previous section we mentioned applying adaptive control to determine the real values for uncertain system parameters. Before explaining the adaptive control scheme we present some assumptions that will be used in this work.

A. 1: The desired trajectory $q_d(t) \in \mathcal{C}^2$ is assumed to be known, non-constant and ²

$$\|q_d(t)\|, \|\dot{q}_d(t)\|, \|\ddot{q}_d(t)\| < B \quad (22)$$

with B a positive constant.

A. 2: The mass matrix $M(q)$ satisfies

$$m_m I \leq M(q) \leq m_M I \quad (23)$$

with m_m, m_M positive constants.

A. 3: The potential energy term $\rho(q) = \frac{\partial V}{\partial q}$ satisfies

$$\|\rho(q)\| \leq \gamma \|q\| \quad (24)$$

with γ a positive constant.

A. 4: The mass matrix $M(q)$, the damping matrix $D(q, p)$ and the potential energy term $\rho(q)$ can be expressed in terms of unknown constant real parameters z_1, \dots, z_m :

$$\begin{aligned} M(q) &= \sum_{i=1}^m M_i(q)z_i + M_0(q) \\ D(q, p) &= \sum_{i=1}^m D_i(q, p)z_i + D_0(q, p) \\ \rho(q) &= \sum_{i=1}^m \rho_i(q)z_i + \rho_0(q) \end{aligned} \quad (25)$$

◁

² $\|\cdot\|$ denotes the Euclidean vector norm

In assumption **A.4** M_0, D_0 and ρ_0 describe the parameters of the nominal system. The nominal system is the expected system; in the case of no uncertainty the nominal values are equal to the real values.

Application of (16) in an adaptive scheme is complicated by the term of (16) which depends on $M^{-1}(q)$. The inverse of the matrix cannot be written as the sum of the inverse of the nominal and unknown parts. A possible way to deal with this issue would be to define an auxiliary matrix

$$Q(q, p) = M \frac{\partial(M^{-1}(q)p)}{\partial q} \quad (26)$$

However, because of the matrix inverse it can become very difficult to describe this auxiliary matrix in the form presented in assumption **A.4**. The use of this auxiliary matrix may also mean that we have more unknown parameters to estimate; the parameters of the auxiliary matrix and not only the uncertain physical parameters of the system. Having more unknown parameters to estimate than are actually necessary is not desirable since it will probably slow down the convergence of the tracking error. These are the reasons why an input signal which does not depend on the inverse of the mass matrix is desirable. We will now write the term depending on $M^{-1}(q)$ in a different way such that we avoid matrix inversion. We know that

$$\frac{\partial(M^{-1}(q)p)}{\partial q} = \left(\frac{\partial M^{-1}(q)}{\partial q_1} p, \dots, \frac{\partial M^{-1}(q)}{\partial q_k} p \right) \quad (27)$$

where we can also write

$$\frac{\partial M^{-1}(q)}{\partial q_j} = -M^{-1}(q) \frac{\partial M(q)}{\partial q_j} M^{-1}(q) \quad (28)$$

with $j = 1, \dots, k$. Because $p = M(q)\dot{q}$ and by (28) we get

$$M \frac{\partial(M^{-1}(q)p)}{\partial q} = - \frac{\partial(M(q)\dot{q})}{\partial q} \quad (29)$$

The control input (16) can then be written such that it does not depend anymore on $M^{-1}(q)$. From (12), with $G = I$, we know that $y = \dot{q}$ so we can replace \dot{q} by y in our feedback, with (19), (20) and (21).

Because of parameter uncertainty the tracking input (16), with (21), can be given by a nominal part $u_0(q, y, t)$, depending on the nominal parameter values, and by an error caused by the unknown parameters:

$$\begin{aligned} u &= u_0(q, y, t) + \Delta(q, y, t)z \\ &= M_0(q)\ddot{q}_d - \left(\frac{1}{2} \frac{\partial(M_0(q)\dot{q}_d)}{\partial q}^\top - \frac{1}{2} \frac{\partial(M_0(q)\dot{q}_d)}{\partial q} \right. \\ &\quad \left. - \frac{1}{2} \frac{\partial(M_0(q)y)}{\partial q} - D_0 \right) \dot{q}_d + \rho_0(q) - K_p\bar{q} \\ &\quad - K_d\bar{y} + \Delta(q, y, t)z \end{aligned} \quad (30)$$

with the unknown vector $z = (z_1, \dots, z_m)^\top$ and the matrix $\Delta(q, y, t) = (h_1, \dots, h_m)$,

$$\begin{aligned} h_i &= M_i(q)\ddot{q}_d - \left(\frac{1}{2} \frac{\partial(M_i(q)\dot{q}_d)}{\partial q}^\top - \frac{1}{2} \frac{\partial(M_i(q)\dot{q}_d)}{\partial q} \right. \\ &\quad \left. - \frac{1}{2} \frac{\partial(M_i(q)y)}{\partial q} - D_i \right) \dot{q}_d + \rho_i(q) \end{aligned} \quad (31)$$

$i = 1, \dots, m$. The nominal control input $u_0(q, y, t)$, with position and velocity measurements, would result in the error system

$$\begin{bmatrix} \dot{\hat{q}} \\ \dot{\hat{p}} \end{bmatrix} = \begin{bmatrix} 0 & I \\ -I & \bar{J}_2 - \hat{D} \end{bmatrix} \begin{bmatrix} \frac{\partial \bar{H}}{\partial \bar{q}} \\ \frac{\partial \bar{H}}{\partial \bar{p}} \end{bmatrix} - \begin{bmatrix} 0 \\ \Delta \end{bmatrix} z \quad (32)$$

where $\hat{D} = \bar{D} + K_d$ instead of the error system (17) with (21). It shows how errors in the parameter values influence the error system.

Since the vector z is unknown we propose to apply the tracking control input for system (12)

$$\begin{aligned} u &= u_0(q, y, t) + \Delta(q, y, t)\hat{z} \\ &= M_0(q)\ddot{q}_d - \left(\frac{1}{2} \frac{\partial(M_0(q)\dot{q}_d)}{\partial q}^\top - \frac{1}{2} \frac{\partial(M_0(q)\dot{q}_d)}{\partial q} \right. \\ &\quad \left. - \frac{1}{2} \frac{\partial(M_0(q)y)}{\partial q} - D_0 \right) \dot{q}_d + \rho_0(q) - K_p \bar{q} \\ &\quad - K_d \bar{y} + \Delta(q, y, t)\hat{z} \end{aligned} \quad (33)$$

with \hat{z} the estimate of z . Define the estimation error by $\bar{z} = \hat{z} - z$. The adaptive input together with the skew-symmetric property of the interconnection matrix of PH systems give the adaptation law

$$\dot{\hat{z}} = -K_a \Delta(q, y, t)^\top \bar{y} \quad (34)$$

with K_a a positive-definite diagonal matrix, which are the adaptation law gains, and

$$\begin{aligned} \bar{y} &= M^{-1}(q)\bar{p} \\ &= \dot{q} - \dot{q}_d(t) \end{aligned}$$

The error system with adaptive control can then be given by ³

$$\begin{bmatrix} \dot{\hat{q}} \\ \dot{\hat{p}} \\ \dot{\hat{z}} \end{bmatrix} = \begin{bmatrix} 0 & I & 0 \\ -I & \bar{J}_2 - \hat{D} & \Delta K_a \\ 0 & -K_a \Delta^\top & 0 \end{bmatrix} \begin{bmatrix} \frac{\partial \mathcal{H}}{\partial \bar{q}} \\ \frac{\partial \mathcal{H}}{\partial \bar{p}} \\ \frac{\partial \mathcal{H}}{\partial \bar{z}} \end{bmatrix} \quad (35)$$

with \mathcal{H} the Hamiltonian of this error system

$$\mathcal{H} = \frac{1}{2} \bar{p}^\top M^{-1}(q)\bar{p} + \frac{1}{2} \bar{q}^\top K_p \bar{q} + \frac{1}{2} \bar{z}^\top K_a^{-1} \bar{z} \quad (36)$$

We first give Barbalat's lemma [6], [9], often used for analysis of nonautonomous systems, which will be used for the proof of our adaptive tracking proposition.

Lemma 1 (Barbalat): Let $\varphi(t) : \mathbb{R} \rightarrow \mathbb{R}$ be a uniformly continuous function on $[0, \infty)$. Suppose that the limit of $\int_0^t \varphi(\tau) d\tau$ as t tends to infinity exists and is finite. Then,

$$\lim_{t \rightarrow \infty} \varphi(t) = 0 \quad (37)$$

◁

Theorem 3: Consider the standard mechanical system (12). Under assumptions A.1-A.4 and assuming that the position q and velocity \dot{q} are available, the control input (33)

³Since z is constant, $\dot{\hat{z}} = \dot{z}$.

with adaptation law (34) realizes global uniform asymptotic tracking of desired trajectories.

Proof. As mentioned before parameter uncertainty causes an error in the control input, given by $\Delta(q, y, t)z$, which can also be seen in the resulting error system (35). Take (36) as Lyapunov candidate function. Then

$$\begin{aligned} \dot{\mathcal{H}} &= -\bar{p}^\top M^{-1}(q)\hat{D}M^{-1}(q)\bar{p} \\ &= -\bar{y}^\top \hat{D} \bar{y} \end{aligned} \quad (38)$$

and since \bar{D} and K_d are positive definite and time-invariant we have

$$\dot{\mathcal{H}} \leq -\varepsilon \|\bar{y}\|^2 \quad (39)$$

with ε a positive constant. The Lyapunov candidate function (36) is lower bounded and $\dot{\mathcal{H}}$ is uniform continuous in time by checking $\dot{\mathcal{H}}$, so Barbalat's lemma with $\varphi = \dot{\mathcal{H}}$ implies that $\bar{y} \rightarrow 0$, as $t \rightarrow \infty$. The kinetic energy of the Hamiltonian (36) then goes to zero, since $\bar{y} = M^{-1}(q)\bar{p}$. Then, since K_p and K_a are constant matrices \bar{q} and \bar{z} become constant as $t \rightarrow \infty$. Since $\bar{y} \rightarrow 0$ as $t \rightarrow \infty$, $\bar{p} \rightarrow 0$ and we know that $\dot{\bar{p}}$ becomes zero too. For $\bar{p} = 0$ we have

$$\begin{aligned} \dot{\bar{p}} &= -K_p \bar{q} + \Delta(q, y, t)\bar{z} \\ &= 0 \end{aligned}$$

Because of assumption A.1 the matrix $\Delta(q, y, t)$ is not constant and because \bar{q} and \bar{z} become constants $\dot{\bar{p}} \equiv 0$ only when $\bar{q} \equiv 0$ and $\bar{z} \equiv 0$. Hence the system is asymptotically stable. Since (36) is also decrescent the error system (35) is uniformly asymptotically stable. ◻

For tracking control a non-constant $\Delta(q, y, t)$ can be assured since for a desired trajectory the changes in the desired positions will cause a change in the desired velocities and accelerations. However, the method cannot be assured to work for stabilization since convergence of velocities to zero may still result in a steady-state error. Remember that the adaptation law is driven by the velocity errors.

In the literature [5], [10], [11], [12], [13], [14], to name a few, usually the error signal is redefined:

$$\begin{aligned} s &= \dot{\hat{q}} + \Lambda \bar{q} \\ \dot{q}_r &= \dot{q}_d - \Lambda \bar{q} \end{aligned}$$

with Λ a positive definite matrix. The control input and update law in those cases then depend on s , a regressor matrix $Y(q, \dot{q}, \dot{q}_r, \ddot{q}_r)$ and the estimation of unknown/uncertain parameters. The method proposed in this paper does not require such a definition of the error signal. The adaptive input, which compensates for errors, together with the skew-symmetry of the interconnection matrix of the error system directly results in the adaptation law for the uncertain parameters and passivity of the error system.

IV. EXAMPLE

2R planar manipulator

The adaptive tracking control is applied on a fully actuated 2 DOF planar manipulator (2R planar manipulator). The

system is shown in figure 1. The manipulator has links with length l_i , angles θ_i , mass m_i , the center of the mass is denoted by r_i and the moment of inertia I_i with $i = 1, 2$. The

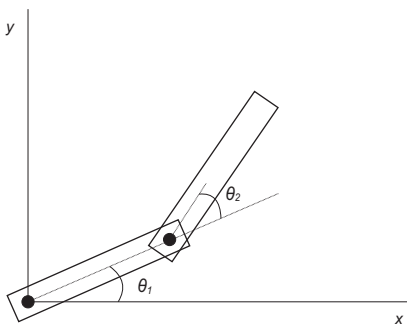

Fig. 1. 2R planar manipulator.

system works in the horizontal plane so gravity influence can be neglected. The Hamiltonian can then be defined by only kinetic energy:

$$H(q, p) = \frac{1}{2} p^\top M^{-1}(q) p \quad (40)$$

with $q = (\theta_1, \theta_2)^\top$ and $p = M(q)\dot{q}$. Define the constants

$$\begin{aligned} a_1 &= m_1 r_1^2 + m_2 l_1^2 + I_1 \\ a_2 &= m_2 r_2^2 + I_2 \\ b &= m_2 l_1 r_2 \end{aligned}$$

The mass matrix becomes

$$M(q) = \begin{bmatrix} a_1 + a_2 + 2b \cos \theta_2 & a_2 + b \cos \theta_2 \\ a_2 + b \cos \theta_2 & a_2 \end{bmatrix} \quad (41)$$

This system can be described as a standard PH mechanical system (12) with G a 2×2 identity matrix since the system is fully actuated with input signal $u = (u_1, u_2)$ which are the control torques on the two joints. The damping matrix is assumed to be constant, $D = \text{diag}\{d_1, d_2\}$.

Simulation results

For simplicity the system parameters are chosen to be all equal to one. Furthermore we have $K_p = \text{diag}\{20, 20\}$ and $K_d = \text{diag}\{10, 10\}$, where K_p is the matrix of controller gains and K_d the matrix of the additional (injected) damping constants. The desired joint angles are

$$q_{1d}(t) = \theta_{1d}(t) = c_1 \sin \omega_1 t \quad (42)$$

$$q_{2d}(t) = \theta_{2d}(t) = c_2 \sin \omega_2 t \quad (43)$$

where $c_1 = c_2 = \omega_1 = \omega_2 = 1$. It is assumed that the values of the masses m_1, m_2 and the values of the damping matrix d_1, d_2 are uncertain/unknown. Take z_1 as the unknown part of m_1 , z_2 as the unknown part of m_2 , z_3 and z_4 as the unknown parts of d_1 and d_2 respectively. For this example we then have

$$M_1 = \begin{bmatrix} r_1^2 & 0 \\ 0 & 0 \end{bmatrix}, \quad D_1 = \begin{bmatrix} 1 & 0 \\ 0 & 0 \end{bmatrix}, \quad D_2 = \begin{bmatrix} 0 & 0 \\ 0 & 1 \end{bmatrix},$$

$$M_2(q) = \begin{bmatrix} l_1^2 + r_2^2 + 2l_1 r_2 \cos \theta_2 & r_2^2 + l_1 r_2 \cos \theta_2 \\ r_2^2 + l_1 r_2 \cos \theta_2 & r_2^2 \end{bmatrix}$$

Table I shows the nominal and real values used in this example. Figure 2 shows how the system reacts when there

TABLE I
UNCERTAIN PARAMETER VALUES

Parameter	Nominal	Real
m_1	1.2	1
m_2	1.2	1
d_1	0	1
d_2	0	1

is no adaptive control, i.e., $\Delta \hat{z} = 0$ for $t \geq 0$. Notice

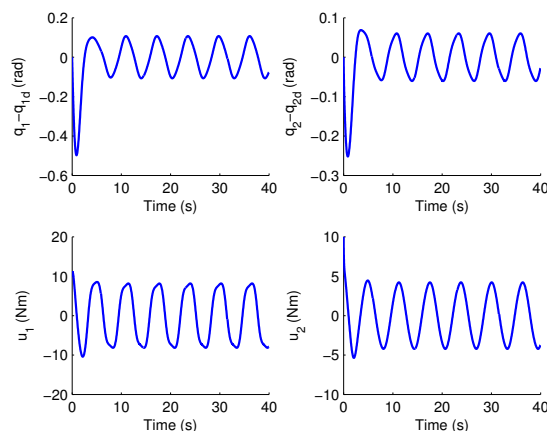

Fig. 2. Error trajectories for the 2R planar manipulator with uncertainty and no adaptive control. Initial conditions: $[q(0) \ p(0)] = [0 \ 0 \ 0 \ 0]$

how a relatively small error in the masses and not taking damping into account can result in a relatively large tracking error. Next the adaptive control input is added, where the matrix K_a of adaptive law gains is chosen equal to $K_a = \text{diag}\{3, 3, 10, 10\}$. Figure 3 shows the trajectories for the manipulator and figure 4 the estimation of the uncertain parameter values. It can be seen that the tracking errors converge to zero and that the estimation of the parameter values converge to the real values. It should be pointed out that figure 4 does not show the trajectories of \hat{z} , but of \hat{z} plus the nominal parameter values (given in table I). Remember from assumption A.4 that \hat{z} is the estimation of the error in the parameters.

V. TRANSIENT PERFORMANCE

Simulations have also shown that the transient performance of the error system is sensitive to initial conditions. When $\bar{q}(0) \neq 0$ convergence to a zero error becomes slower. The sensitivity to initial conditions for other adaptive schemes has been analyzed in [8], where bounds were determined for the \mathcal{L}_2 -norm and the \mathcal{L}_∞ -norm of the error states. It was shown that the bounds increase when the initial errors are not equal to zero.

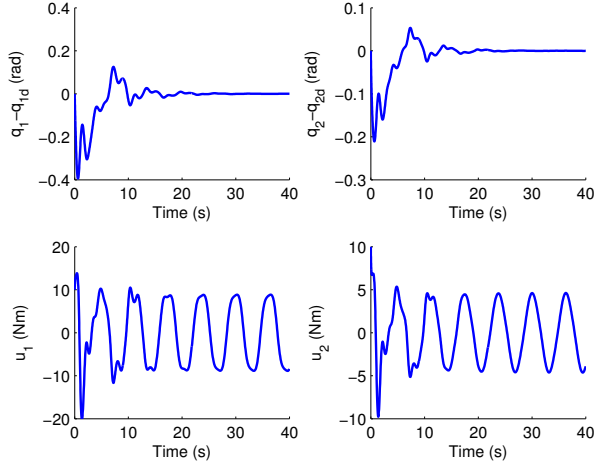

Fig. 3. Error trajectories for the 2R planar manipulator with uncertainty and adaptive control. Initial conditions: $[q(0) \ p(0)] = [0 \ 0 \ 0 \ 0]$.

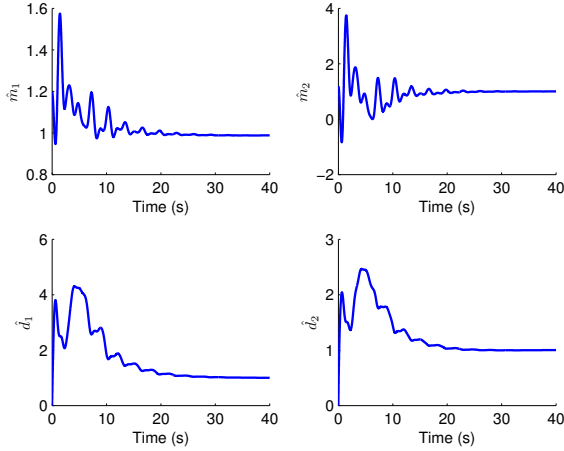

Fig. 4. Estimation of uncertain parameters.

From (38) we know that

$$\dot{\mathcal{H}} \leq -\lambda \|\bar{y}\|^2 \quad (44)$$

with constant $\lambda > 0$. Similar to [8] and based on (44) we find the (square) \mathcal{L}_2 -norm for our adaptive scheme to be

$$\begin{aligned} \|\bar{y}\|_2^2 &= \int_0^\infty \|\bar{y}(\tau)\|^2 d\tau \leq -\frac{1}{\lambda} \int_0^\infty \dot{\mathcal{H}}(\tau) d\tau \\ &\leq \frac{1}{\lambda} (\mathcal{H}(0) - \mathcal{H}(\infty)) \\ &\leq \frac{1}{\lambda} \mathcal{H}(0) \end{aligned} \quad (45)$$

The square of the \mathcal{L}_2 -norm is the energy in the signal. We have seen in the previous section that \dot{z} depends on \bar{y} . A higher bound on $\|\bar{y}\|_2$ means a higher bound on $\|\dot{z}\|_2$, indicating faster changes and probably higher values for \dot{z} . The large errors during the initial period cause poor estimates

which slow down the convergence. Furthermore, the control input (33) also depends on \bar{y} , so a decrease in the energy in \bar{y} means a decrease in the (initial) input energy. This transient analysis shows the importance of reducing initial errors or application of other techniques (e.g. trajectory initialization in [8]) to set the initial errors to zero.

VI. CONCLUDING REMARKS

A new adaptive control approach has been presented for tracking control of standard fully actuated mechanical systems, described in the PH framework. It is interesting to note that the error system resulting from the canonical transformation [4] and the error system with adaptation given in this paper are both PH. The advantages are the insightful PH structure and the possibilities for tuning the adaptive controller. The adaptive tracking results for EL systems [14], [11] also give a passive error system, however, the resulting error system is not of EL form anymore.

An example was used to show how the adaptive control estimates and compensates for the errors of the uncertain parameters such that the tracking error can converge to zero. We conclude with the remark that the adaptive control scheme can be further extended for general (nonautonomous) PH systems.

REFERENCES

- [1] A. Astolfi, D. Karagiannis, R. Ortega, 2008, Towards applied nonlinear adaptive control, *Annual Reviews in Control* Vol. 32, No. 2, 136-148
- [2] C. Bonivento, L. Gentili, A. Paoli, 2004, Internal model based fault tolerant control of a robot manipulator, *Proceedings IEEE Conference on Decision and Control*, Atlantis, Bahamas
- [3] K. Fujimoto, T. Sugie, 2001, Canonical transformation and stabilization of generalized Hamiltonian systems, *Systems & Control Letters*, Vol. 42, No. 3, 217-227
- [4] K. Fujimoto, K. Sakurama, T. Sugie, 2003, Trajectory tracking of port-controlled Hamiltonian systems via generalized canonical transformations, *Automatica*, Vol. 39, No. 12, 2059-2069
- [5] B. Jayawardhana, G. Weiss, 2009, Tracking and disturbance rejection for fully actuated mechanical systems, *Automatica*, Vol. 44, No. 12, 3036-3045
- [6] H. Khalil, 1996, *Nonlinear Systems*, Prentice Hall, Upper Saddle River
- [7] D.E. Koditschek, 1984, Natural motion for robot arms, *Proceedings IEEE Conference on Decision and Control*, Las Vegas, NV, USA
- [8] M. Krstic, I. Kanellakopoulos, P. Kokotovic, 1995, *Nonlinear and Adaptive Control Design*, John Wiley & Sons, New York
- [9] R. Marino, P. Tomei, 1995, *Nonlinear Control Design, Geometric, Adaptive and Robust*, Prentice Hall, London
- [10] R. Ortega, M.W. Spong, 1989, Adaptive motion control of rigid robots: a tutorial, *Automatica*, Vol. 25, No. 6, 877-888
- [11] R. Ortega, A. Loria, P.J. Nicklasson, H. Sira-Ramírez, 1998, *Passivity-based control of Euler-Lagrange systems: mechanical, electrical and electromechanical applications*, London, Springer
- [12] E. Panteley, R. Ortega, M. Gäfvert, 1998, An adaptive friction compensator for global tracking in robot manipulators, *Systems & Control Letters*, Vol. 33, No. 5, 307-313
- [13] J.J.E. Slotine, W. Li, 1988, Adaptive manipulator control: A case study, *IEEE Transactions on Automatic Control*, Vol. 33, No. 11, 995-1003
- [14] J.J.E. Slotine, W. Li, 1991, *Applied Nonlinear Control*, Prentice Hall, New Jersey
- [15] Y. Wang, G. Feng, D. Cheng, 2007, Simultaneous stabilization of a set of nonlinear port-controlled Hamiltonian systems, *Automatica*, Vol. 43, No. 3, 403-415