

University of Groningen

Ceramics on the first millenium BC from a survey at Lanuvium in the Alban Hills

Attema, P.A.J.; van Oortmerssen, Gert

Published in:
 Palaeohistoria

IMPORTANT NOTE: You are advised to consult the publisher's version (publisher's PDF) if you wish to cite from it. Please check the document version below.

Document Version
 Publisher's PDF, also known as Version of record

Publication date:
 2000

[Link to publication in University of Groningen/UMCG research database](#)

Citation for published version (APA):

Attema, P. A. J., & van Oortmerssen, G. (2000). Ceramics on the first millenium BC from a survey at Lanuvium in the Alban Hills. *Palaeohistoria*, 39/40, 412 - 440.

Copyright

Other than for strictly personal use, it is not permitted to download or to forward/distribute the text or part of it without the consent of the author(s) and/or copyright holder(s), unless the work is under an open content license (like Creative Commons).

The publication may also be distributed here under the terms of Article 25fa of the Dutch Copyright Act, indicated by the "Taverne" license. More information can be found on the University of Groningen website: <https://www.rug.nl/library/open-access/self-archiving-pure/taverne-amendment>.

Take-down policy

If you believe that this document breaches copyright please contact us providing details, and we will remove access to the work immediately and investigate your claim.

Downloaded from the University of Groningen/UMCG research database (Pure): <http://www.rug.nl/research/portal>. For technical reasons the number of authors shown on this cover page is limited to 10 maximum.

CERAMICS OF THE FIRST MILLENNIUM BC FROM A SURVEY AT LANUVIUM IN THE ALBAN HILLS, CENTRAL ITALY: METHOD, AIMS AND FIRST RESULTS OF REGIONAL FABRIC CLASSIFICATION

PETER ATTEMA, with a contribution by GERT VAN OORTMERSSEN
Groninger Instituut voor Archeologie, Groningen, Netherlands

ABSTRACT: Researchers at the Groningen Institute of Archaeology (GIA) have developed a fabric classification method that relates surface pottery from the surveys of the Institute's Pontine Region Project (P.R.P.) in South Lazio to pottery from the Institute's stratigraphical excavations at the protohistoric site of Satricum in the same area (c. 60 km south of Rome). In this paper it is argued that classification of the surface pottery on the basis of fabric analysis is the most useful starting point for dealing with the problem of the low chronological and functional resolution of surface materials. Fabric analysis allows us to relate worn body sherds found during surface survey to well-defined pottery groups based on excavated materials. Survey makes it possible, then, to 'trap' moments of increased production and/or increased pottery supply in the wider rural landscape, and to relate such observed changes to socio-economic and political change in the urban sphere. Following an introduction to the overall research programme, the authors explain the fabric classification method and provides an example of its application to a pottery collection from a recent P.R.P. survey at Lanuvium in the Alban hills. The fabric classification is given in an Appendix and covers the local *impasto* and local coarse wares collected in site and off-site contexts in the Lanuvium survey.

KEYWORDS: Central Italy, Alban hills, Lanuvium, Latial archaeology, survey, pottery, pottery fabrics, pottery wares.

1. INTRODUCTION

1.1. Research background

The fabric classification presented in this paper is based on the result of the quantitative processing of sherds collected during an intensive survey by the Pontine Region Project (P.R.P.) in September/October 1995 in the catchment of ancient Lanuvium in the Alban hills, to the southeast of Rome (Attema, 1996; Attema, Nijboer & van Oortmerssen, 1997).¹ It was the second in a series of three surveys carried out to date in the research programme 'Roman colonization south of Rome, a comparative survey of three early romanized landscapes' (Attema, 1995).²

Fabric analysis of survey material from Lazio is part of a wider long-term research programme on Latial ceramic production, carried out by mediterranean researchers of the G.I.A.³ The programme also involves the ceramics provenient from excavations at the protohistoric site of Satricum at present-day Borgo Le Ferriere. The latter material has stratigraphical context and is for a large part explicitly related to the hut, house and cult features excavated at the site since 1977 (Maaskant-Kleibrink, 1987; 1992; Bouma, 1996). These features cover the period of c. 800 to c. 200 BC. The P.R.P. survey material covers a longer time-span and includes both earlier (Bronze Age) and later periods (the late Roman Republican and Imperial periods) (Attema, 1993).

The research programme has two aims: firstly to

establish a regional fabric classification system of 'common' sherd material as an integral part of a comprehensive ware typology and functional classification of the pottery from the Pontine Region. This classification will be made concordant with existing typologies (e.g. Carafa, 1995; Bettelli, 1997), and will be published in a field manual for quantitative and qualitative processing of excavation and survey ceramics derived from fieldwork in this area. Our second aim is to understand the changes in ceramic technology and the organization of ceramic production, a field of study which we feel is important for our understanding of centralization, urbanization and colonization processes in first millennium BC Lazio.⁴

In the specific context of the research programme 'Roman colonization south of Rome', attention was focused on the relation between changing ceramic technology and early Latin/Roman colonization.

1.2. Comparative pottery studies

Between 1994 and 1997 sample areas in the rural catchments of three Roman towns were surveyed, two of them Latin colonies (Sezze or ancient *Setia* in the Agro Pontino, and Segni or ancient *Signia* in the Sacco valley), the other a *municipium* (Lanuvio or ancient Lanuvium in the Alban hills, near Rome) (fig. 1). The surveys were designed to test three different models of colonization postulated in the research formulated on the basis of the results of earlier regional research (Attema, 1993):

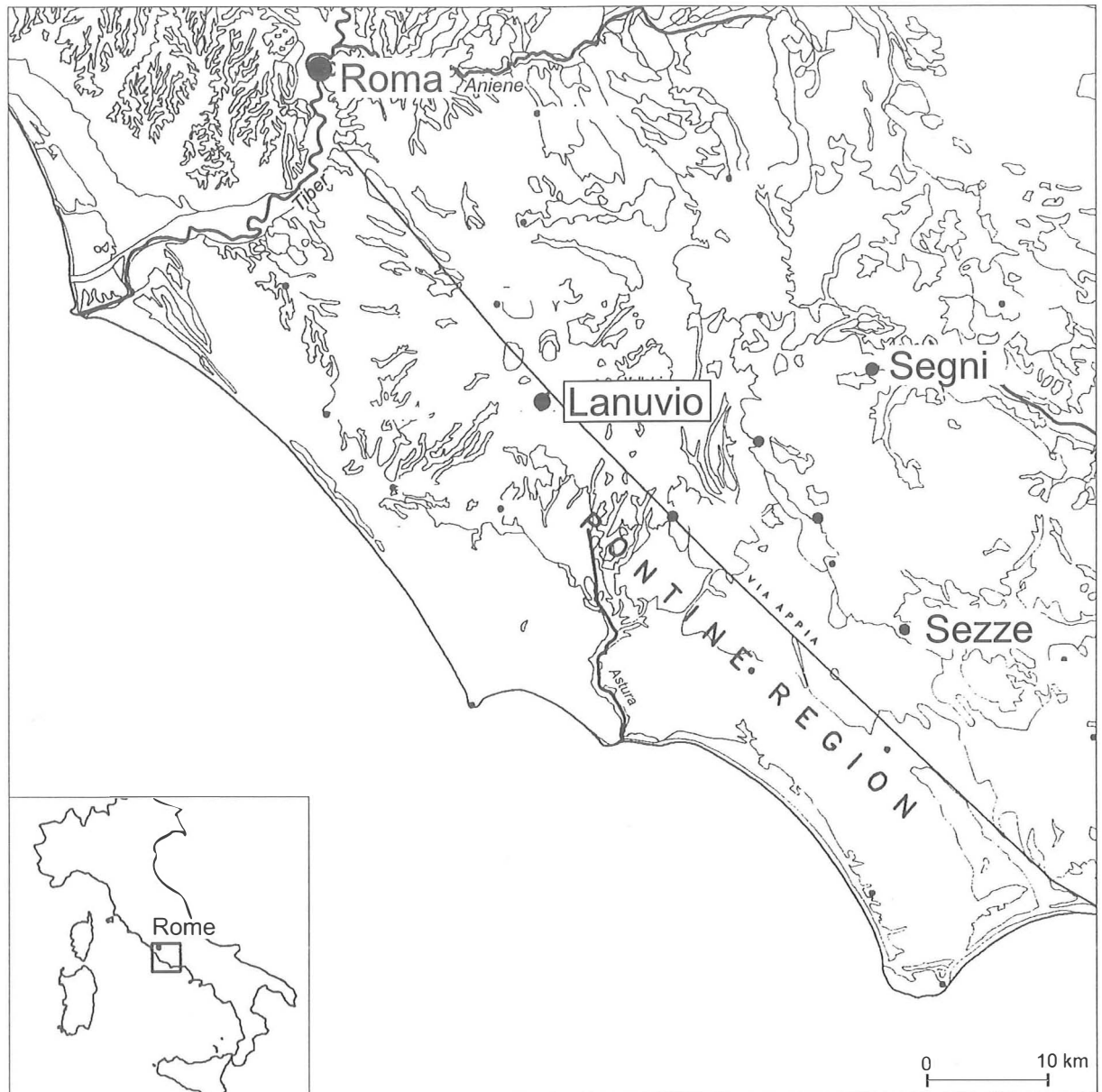

Fig. 1. Location of the survey areas of the research programme 'Roman colonization south of Rome, a comparative survey of three early romanized landscapes'.

- A military/strategic model, historically connected to the earliest expansion of Rome in Latial territory (taking place around 500 BC, test case Segni);

- A rural exploitation model, historically connected to 4th century BC Roman Republican colonial settler policy (test case Sezze);

- A 'suburban' model, of an ancient Latin town being romanized rather than colonized (test case Lanuvium).

Two related research strands were pursued. One was the chronological, functional and spatial comparative study of urban and rural settlement patterns in the three landscapes; this was intended to highlight regional

correspondences and differences in Roman colonial strategies and to evaluate the impact of early Roman/Latin colonization on the previous Archaic settlement patterns. The other was the comparative study of the surface pottery collected in the sample areas of each catchment; the aim was to 'trap' moments of increased production in pottery supply and production in the catchments of these Roman towns. To this end, large sherd collections from rural contexts were processed, ranging between 10,000 and 34,000 sherds, in the conviction that, to obtain functionally and chronologically meaningful data out of surface scatters, as

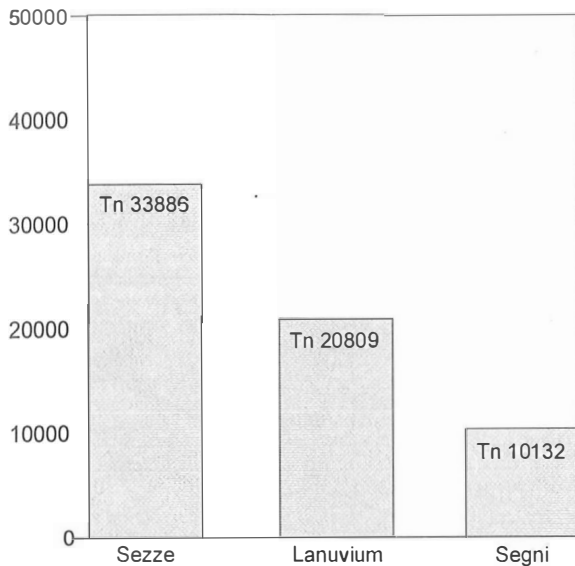

Fig. 2. Totals of sherds collected in the Sezze, Segni and Lanuvium survey.

many fragments as possible need to be classified (cf. Attema, Haagsma & Delvigne, 1997; MacDonald, 1995) (fig. 2).

As expected, the Lanuvio sherd collection showed continuity in ceramic production and supply from the Iron Age to the Roman period. It was therefore selected to be the first to be subjected to a detailed fabric analysis. At a later stage of the project, the results from the Lanuvium survey pottery will be compared with the fabric data from the Segni and Sezze collections in order to study the chronology and intensity of Roman presence in the areas of Roman expansion.

1.3. Outline of this paper

First, the archaeological context of the survey ceramics and the sorting procedures followed during fieldwork will be discussed; I will then proceed to explain the fabric classification method. The actual fabric classification of the Lanuvio sherd collection is presented in the Appendix. In comments on the fabrics and in a diagram (fig. 9), I will highlight links with ware groups known from stratigraphical contexts at the protohistorical site of Satricum. The classification comprises local *impasto* fabrics, coarse fabrics, and depurated fabrics with volcanic inclusions. It excludes imported materials (depurated and coarse), local depurated material, and fine wares such as black glazed ware and terra sigillata. These will be treated elsewhere. The paper concludes with remarks on general trends in the production of tiles, *impasto*, and coarse ware pottery in the Pontine Region in the first millennium BC.

2. ARCHAEOLOGICAL AND METHODOLOGICAL CONTEXT

2.1. Rural settlement in the Lanuvium catchment

The ceramics collected during the survey cover the period from the later Iron Age to Roman Imperial times and were mostly collected in the rural catchment of Lanuvio.⁵ The originally Latin settlement of Lanuvium, as is its ancient name, is situated on the southeast flank of the Alban volcano, overlooking the Pontine plain (fig. 3). Rome made the independent Latin city of Lanuvium into a *municipium* in the early 4th century BC, after which it continued to flourish well into the Imperial period (Chiarucci, 1983: pp. 27-34).

The survey data suggest that in the later Iron Age (8th and 7th centuries BC) the lower hills of the Alban volcano to the south of the settlement of Lanuvium, became sparsely settled by Iron Age farming communities. Earlier, settlement had concentrated mainly along the rim of the primary caldera (Chiarucci, 1978). By the later 6th century BC a rural settlement hierarchy had developed that was dependent on Lanuvium as its central place. On the basis of the pottery scatters found during the survey, we can suppose that each hill surrounding Lanuvium featured more than one settlement unit in the Archaic period (6th century BC) and the post-Archaic period (5th/4th century BC) (fig. 4). In this early period we are undoubtedly dealing with very modest farmsteads with wattle and daub walls founded on walls in tuff stone and having a (partly) tiled roof. Ceramic scatters are small and lack the massive stone building debris that characterizes scatters from Republican farmsteads of the late 4th century BC onwards. The latter were sometimes built on free-standing stone platforms, placed centrally on the hill tops dominating the former Archaic rural landscape. This agricultural exploitation system with strategically placed 'villa farms' is found in large parts of South Lazio during this period (Attema, 1996).⁶

2.2. Surface artefact collection procedures

Sherds were collected from site and off-site contexts using three different methods. So-called 'string-squares' were used to sample discrete ceramic scatters (sites), individuated by field walkers in their transects. This controlled collection method was used to estimate density and chronological range of the ceramics in both the core and the periphery of each scatter. The method calls for one team member to collect all artefacts from the surface of a 4x4 quadrat, forcing him or her to make an unbiased sherd collection. Grab sampling (i.e. non-systematical collecting) served to complement the string-square collections made at sites with fabric and/or form diagnostic sherds and were especially helpful in the functional interpretation of scatters. Transect finds in the survey were those artefacts that were actually col-

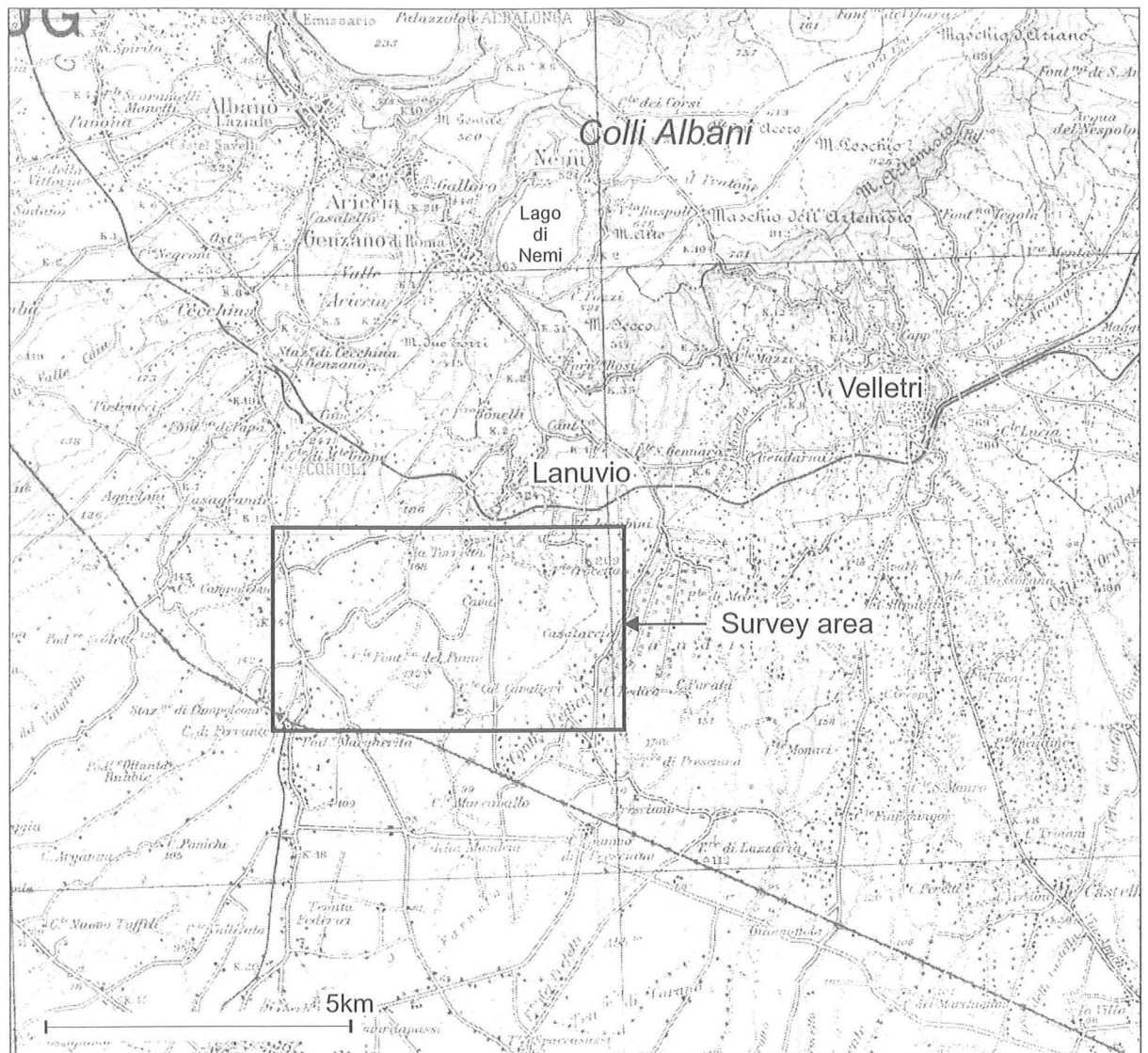

Fig. 3. Lanuvium and survey area.

lected – and not merely counted – in off-scatter (off-site) situations along the transects. Collected were those sherds that were thought to have diagnostic value.

The recording of material not related to obvious scatters served to estimate the intensity of land use for the various periods under study, besides complementing the scatter collections. The resulting ceramic samples of the three collection modes furnish the quantitative and qualitative basis of the present study.

2.3. Sorting procedures: the reference collection

In order to sort, count and weigh the ceramics that were brought in from the field, experienced team members created a reference collection from ceramic specimens that were considered to have distinct fabric characteris-

tics. The main criteria by which the sherds were judged were the colour of the clay matrix and the quantity, sorting and type(s) of mineral and other inclusions. Such characteristics were assessed by naked eye on the evidence of the sherd's core after it had been intentionally broken. Munsell soil colour charts were used, as well as charts to estimate percentages of inclusions and degree of sorting. When a sherd did not fit an existing reference in the collection, a new reference was added. The result of this procedure, in the case of the Lanuvium survey, was a collection of 114 ceramic references, an outcome based on the processing of 20.809 sherds of which 16.480 sherds were large enough to assign them to a reference. The average weight of classified sherds was 26 gr.

Of the 114 references, 60 were considered to belong

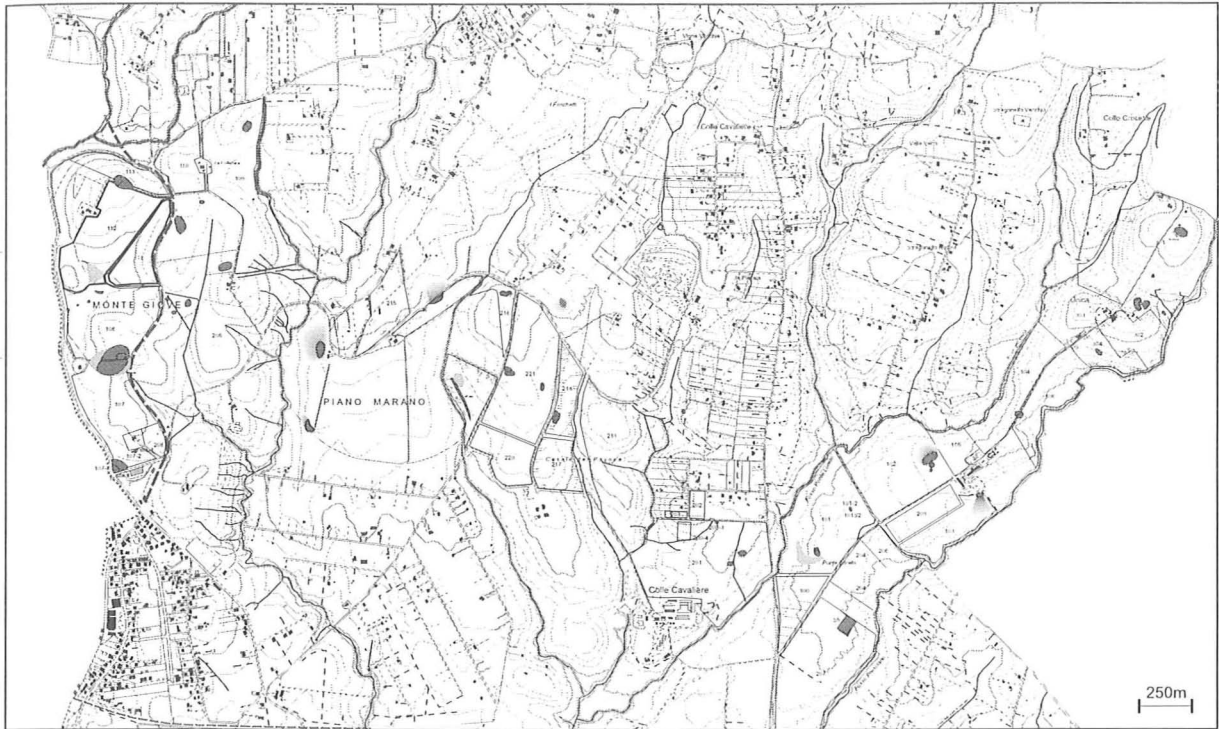

Fig. 4. Lanuvium survey area with scatters.

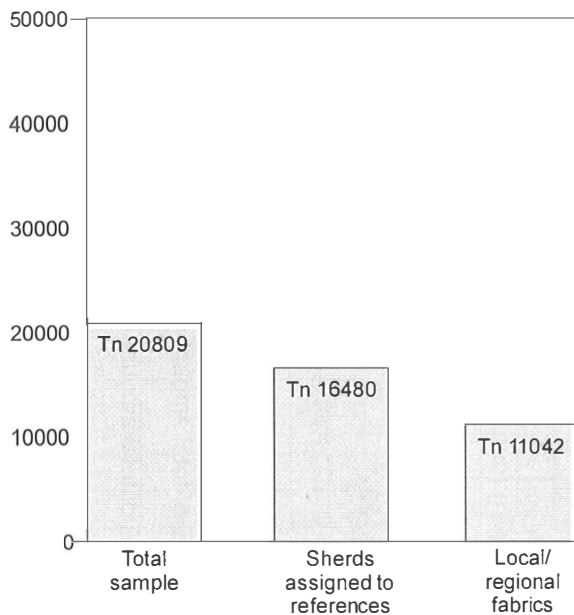

Fig. 5. Percentage of sherds of total sample assigned to references and percentage of sherds of the latter category belonging to *impasto* fabrics, coarse wares and depurated tiles with volcanic inclusions.

to the category of locally made ceramics. Sherds assigned to these 60 references accounted for 67% of the total number of assigned sherds – a score mirroring the importance of this group. The bulk of these (11,042

sherds) belongs to storage and cooking pottery and roof tiles of various types and sizes (fig. 5). The clays used for this group from the Bronze Age to Roman Imperial times are characterized by the inclusion of volcanic minerals and/or FeMn concretions and/or quartz/feldspar.

The remaining 54 references (not discussed in this paper) relate to imported *amphorae*/jugs, to local or imported depurated pottery (including *amphorae*/jugs) and fine wares such as black glazed ware and terra sigillata. The use of depurated fabrics for the manufacture of everyday pottery only occurs on a larger scale from the 5th century BC.

The next step in the processing of the pottery was the amalgamation of the 114 references into laboratory assessed fabric families and groups with a fixed set of characteristics within a defined variability range.⁷

3. THE CLASSIFICATION

3.1. Classification criteria

The amalgamation of the pottery reference types pertaining to local production of *impasto*, coarse pottery, and roof tiles into fabrics led to the identification of three fabric families based on the colours visible in the pottery core just beneath the surface. Following Adams & Adams (1991: p. 266) 'fabric' is defined as "a

LANUVIUM colour family I (red):

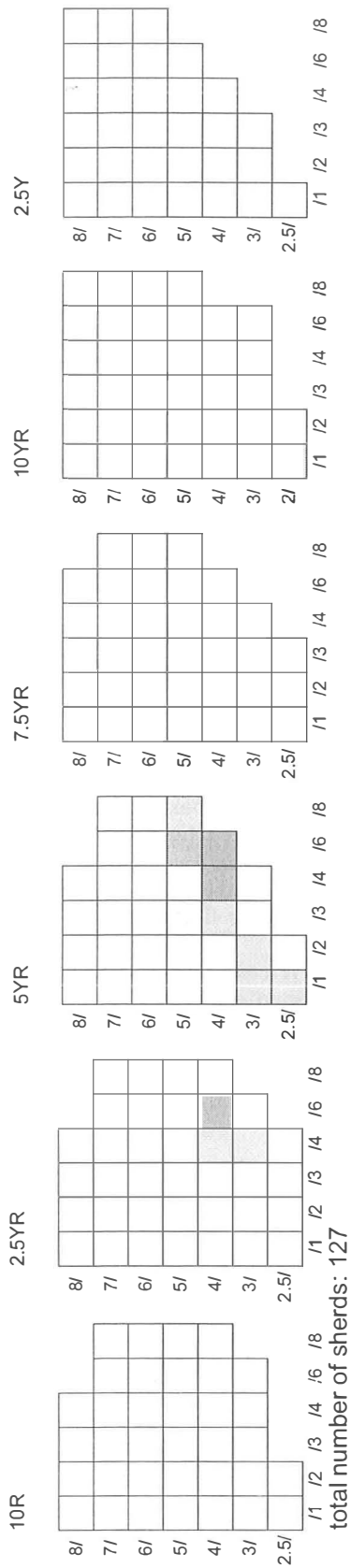

LANUVIUM colour family I (red):

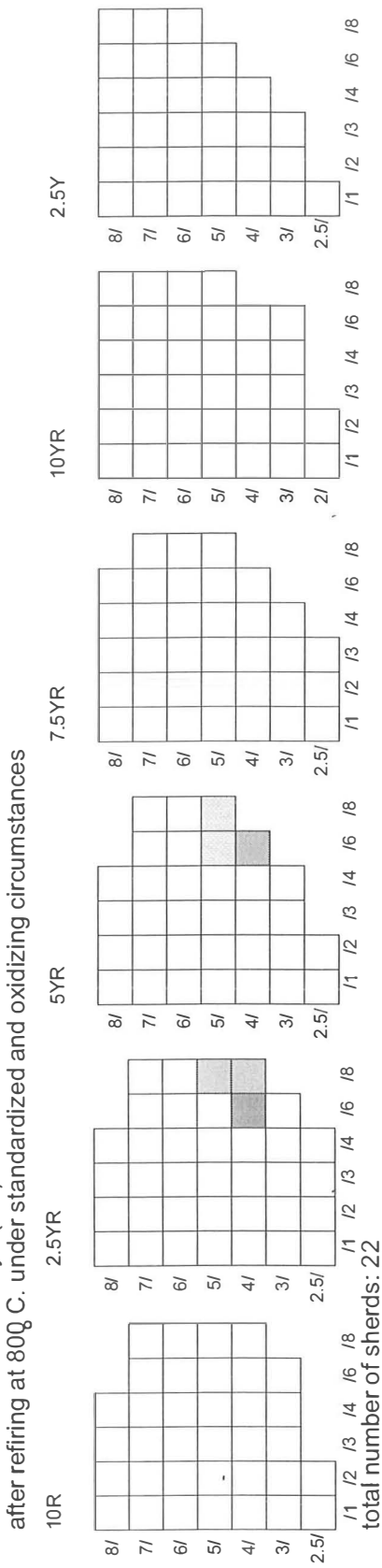

- absent
- present up to 10% of total amount of sherds
- present up to 20% of total amount of sherds
- present up to 30% of total amount of sherds
- present up to 40% of total amount of sherds

Fig. 6a. Diagrams showing colour variability of the three main fabric families.

LANUVIUM colour family II (orange):

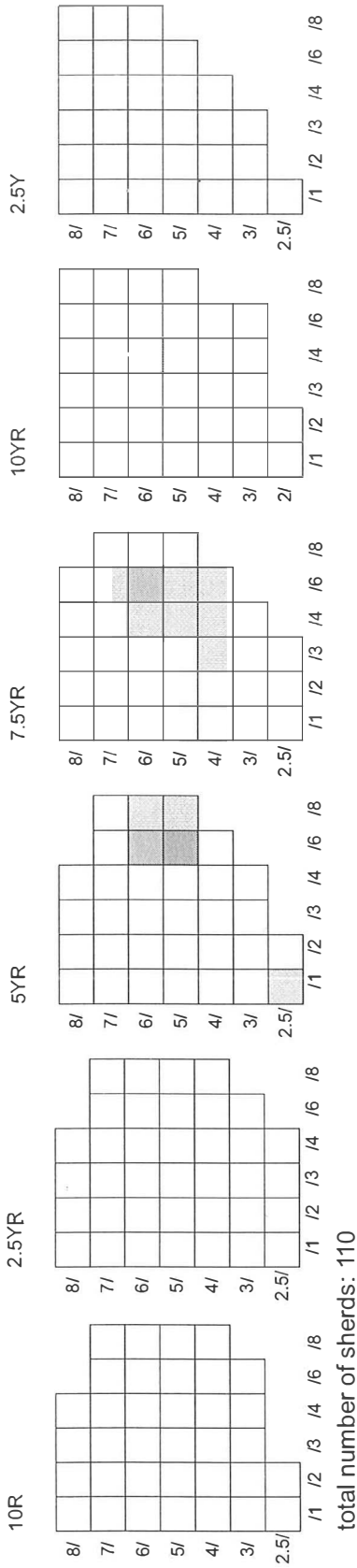

LANUVIUM colour family II (orange):
after refining at 800°C. under standardized and oxidizing circumstances

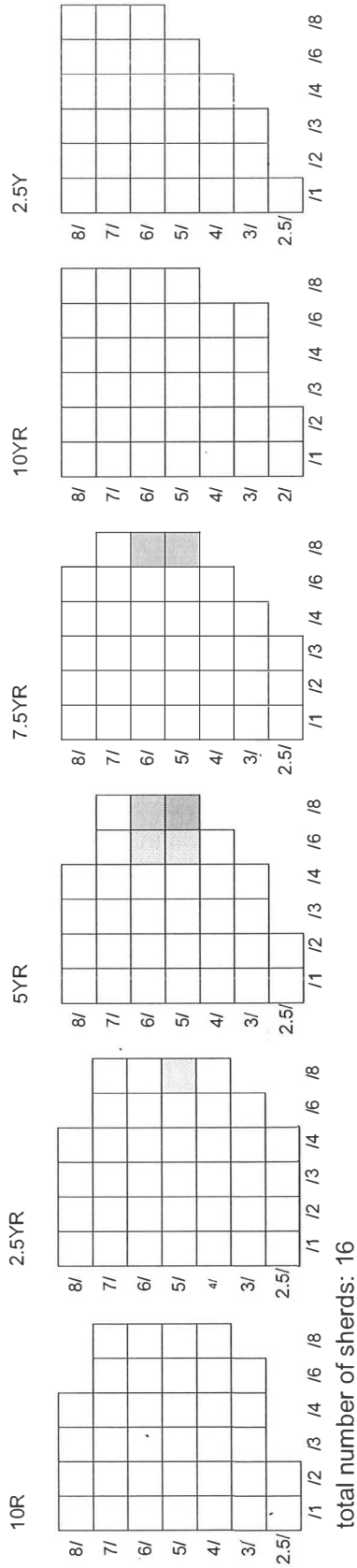

- absent
- present up to 10% of total amount of sherds
- present up to 20% of total amount of sherds
- present up to 30% of total amount of sherds
- present up to 40% of total amount of sherds

Fig. 6b.

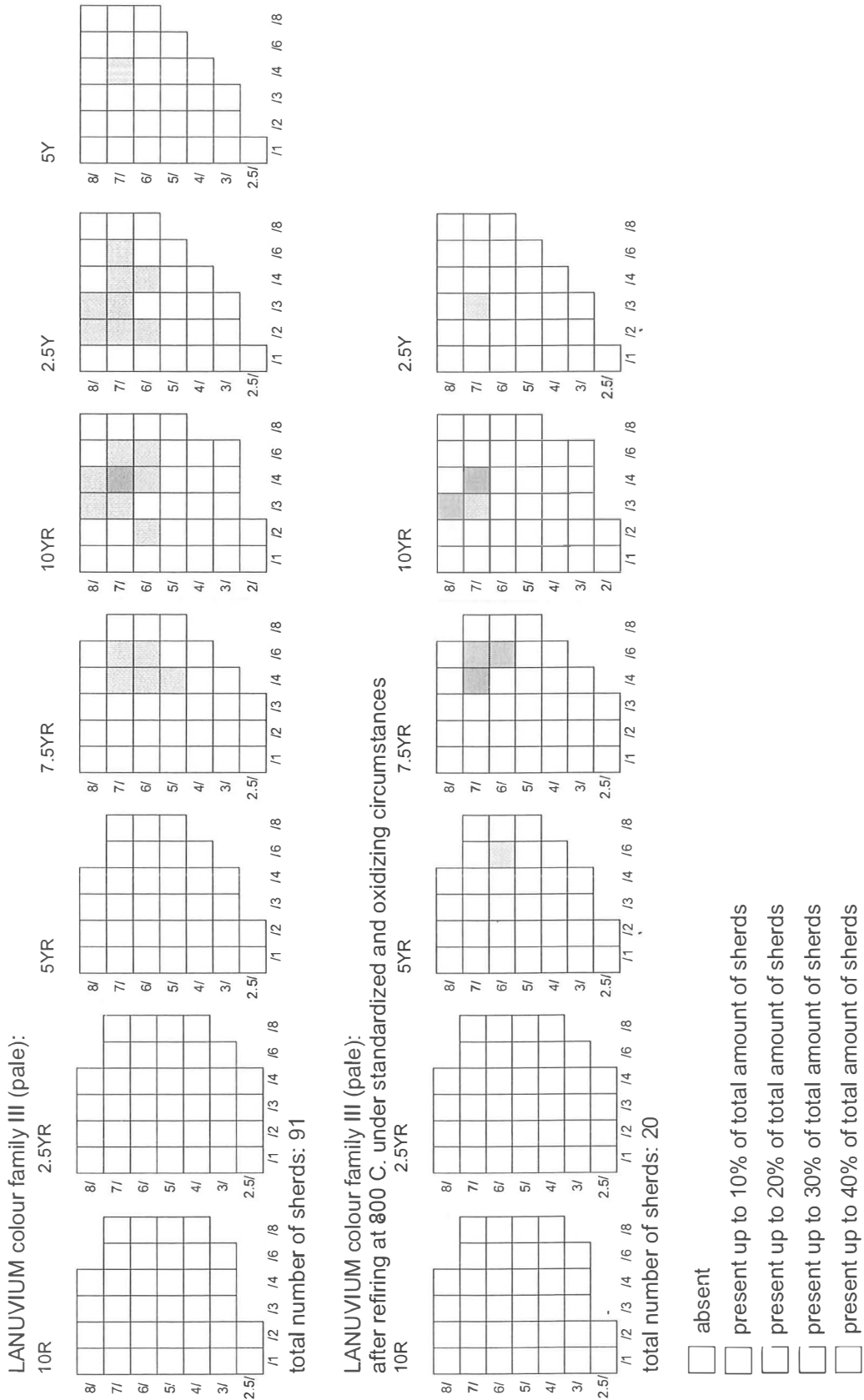

Fig. 6c.

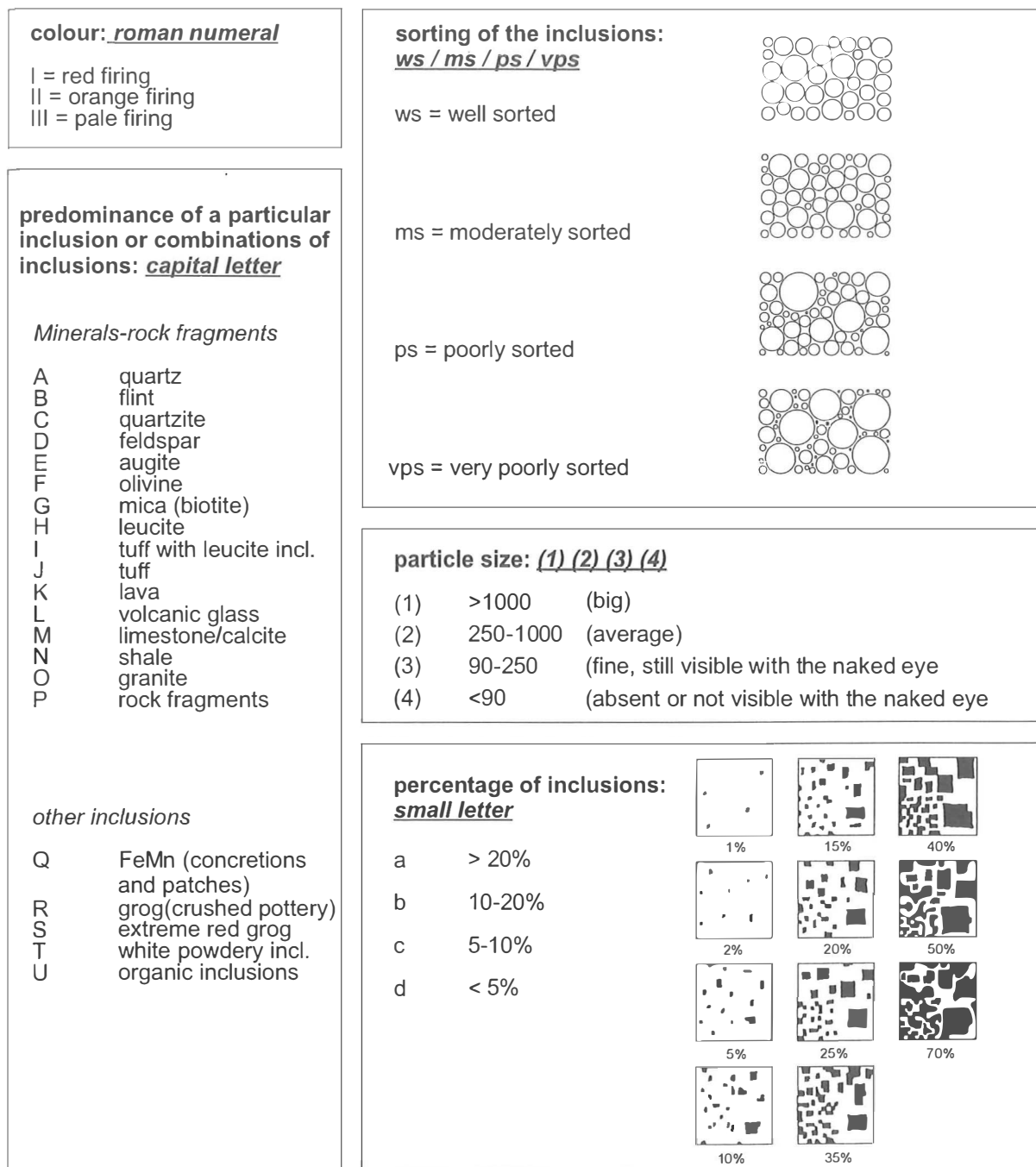

Fig. 7. Codes used in the Groningen Institute of Archaeology fabric classification system: 1. Colour; 2. Predominance of a particular mineral; 3. Sorting of the inclusions; 4. Particle size; 5. Percentage of inclusions.

collective term for the internal constituents used in making pottery. These include the basic clay, marl, or mud which is the primary constituent, and any other material (temper, levigation, etc) which is mixed into the clay, marl or mud to facilitate firing or to impart hardness, porosity, or other characteristics to the vessel walls". Experience with the ceramics from the Satricum excavations had learned that sub-surface colour is a

distinctive criterion. Refiring of representative sherds from each fabric under standardized circumstances confirmed this for the Lanuvium group. To describe colour, Munsell soil color charts were used (Munsell, 1992).

In the fabric classification presented below, we discern a red firing fabric family (LAV I), an orange firing family (LAV II) and a pale firing family (LAV

III). The variability in colour of the three families is illustrated in diagrams, and is based on a refiring programme (fig. 6: a,b,c). Predominance of certain type(s) of inclusion in the clay, percentages of inclusions, their sorting and particle size, as well as the texture of the clay matrix, hardness and fracture (the way the sherd breaks) were the criteria to subdivide the fabric families into fabric groups and/or individual fabrics (fig. 7 and Appendix). Resemblances between fabrics of different fabric groups, or even between fabrics of different families, can be deduced from the label of each fabric, which contains its properties in encoded form.⁸

3.2. Fabric families

The histograms in figure 8 show total numbers of sherds belonging to the three fabric families (fig. 8a) and quantifies the way in which the sherds were collected (string-square, grab-sample or transect find) (fig. 8b). The high scores for the red and pale firing families can be explained by the fact that these contain the traditional fabrics used for roof tiles, storage containers, and smaller storage and cooking pottery. The red firing family has the longest tradition and occurs in the region from the Bronze Age onwards. The earliest datable material of the red firing family in the Lanuvium survey is the early 8th century BC hand-made pottery (*impasto*). In the 7th and 6th centuries BC wheelthrown pottery becomes common in the red firing family.

It is remarkable that the red firing ceramics occur more frequently in transect samples than the orange and pale firing ceramics (37% against 7 and 5% resp.), meaning that the red firing ceramics were mostly found in 'off-site' situations, i.e. not related (anymore) to discrete concentrations of surface material. One explanation is that the Iron Age and Archaic sherds

were already ploughed out of site context by Roman times (the Roman scatters are still more or less in situ).⁹ Another would be that there are in fact red firing scatters, but these are so thin that they were not recognized in the field as coherent entities (sites) under standard survey procedures.¹⁰ A bias, however, might be that red firing sherds were preferentially collected on transects. The descriptions of the counted material on the transect recording sheets suggest, however, that this is not the case.

The observation of a high off-site distribution of red firing ceramics in itself, however, suggests a far denser occupation of the rural catchment around Lanuvium in the 7th and early 6th centuries BC than site density alone would suggest.¹¹ That such rural infill started on a substantial scale in the course of the 7th century BC is evident from a group of late Iron Age fabrics that lacks a predominant mineral (Appendix: LAV I.a). Save for some fragments of the earlier hand-made brown ware, and a handful of Well-burnished Black Ware (see below), these fabrics can for the larger part be related to the so-called Common Red Slip Ware, a 'household' version of the orientaling Fine Slip Ware (in Italian: *impasto rosso*), which dates to the later 7th and 6th centuries BC.

Rural infill intensified in the course of the 6th century BC as is evident from the wide distribution of augite predominant and quartz/feldspar predominant fabrics. These relate to red coarse ware that becomes widespread in this period (see Appendix: LAV I.c and LAV I.e). The orange firing family occurs, save for some hybrid categories between red and orange, in larger quantities only from the start of the 5th century BC. These fabrics are especially indicative of the production of wheelthrown coarse pottery which replaces the red coarse ware cooking and smaller storing pottery (Appendix:

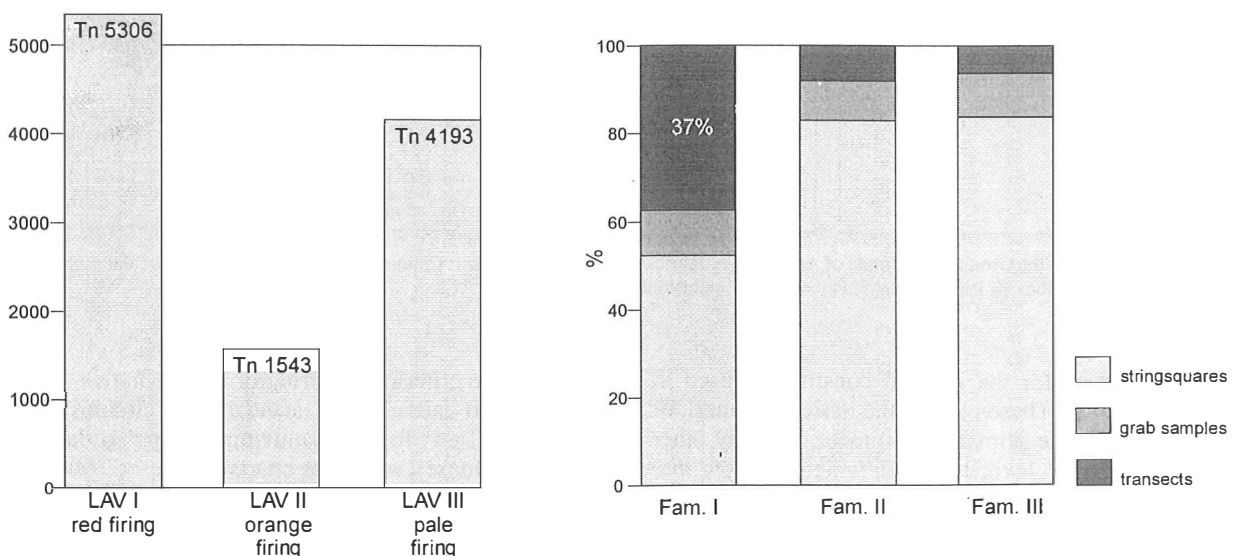

Fig. 8. Totals of sherds per fabric family (a) and percentages of each family found in string-squares, transects and grab samples (b).

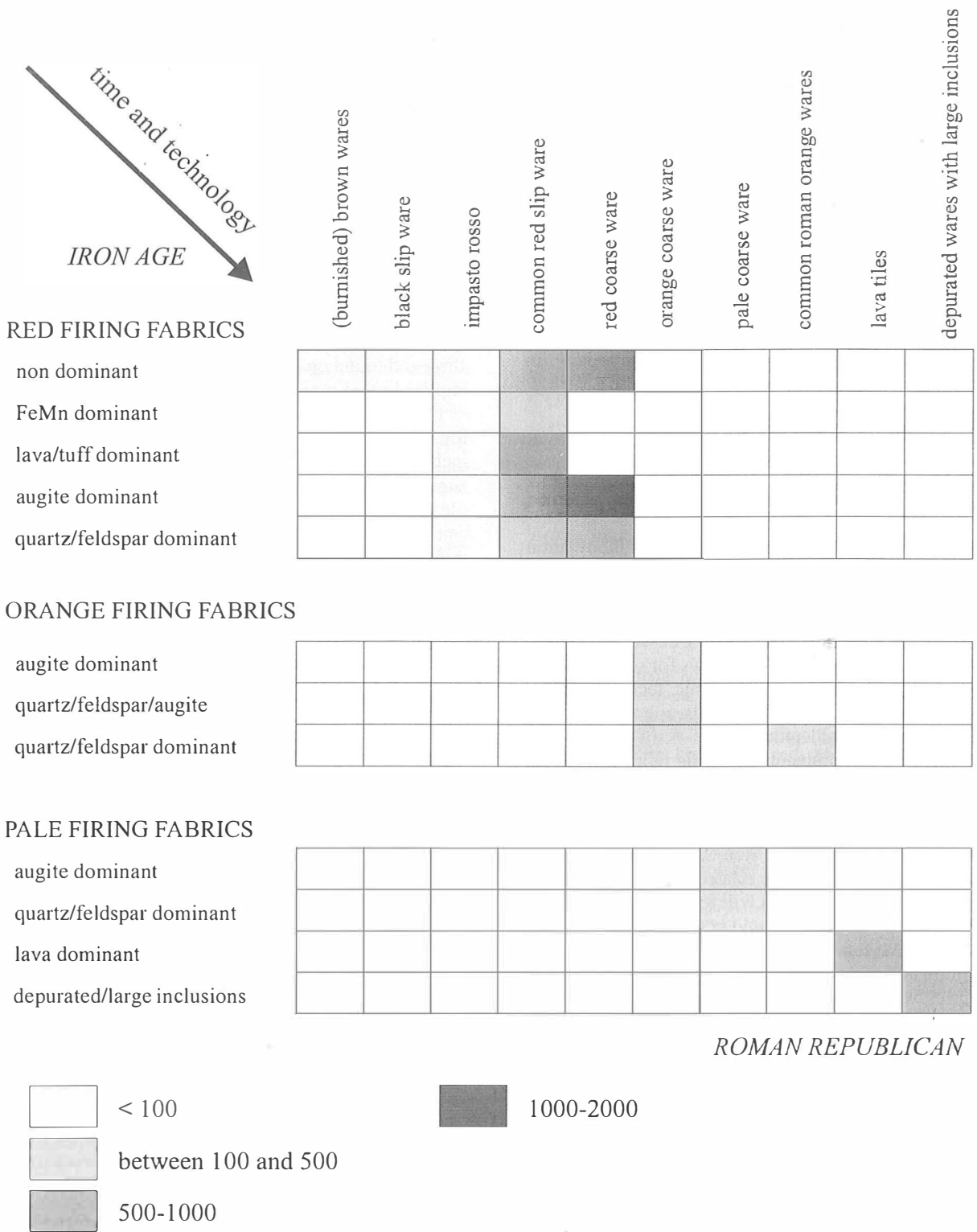

Fig. 9. Fabric groups of the Lanuvium survey and their relation to ware groups known from Satricum. Note the increase in numbers of sherds in the red firing fabrics relating to the 7th century/6th century BC Common Red Slip Ware and Red Coarse Ware.

LAV I). A tendency towards quartz/feldspar predominant clays can be noted (Appendix: LAV II.c, group c.1). The coarser fabrics among these still stand in the Archaic tradition, whereas the depurated and harder fired fabrics (Appendix: LAV II, group c.2) have lost all the typical Archaic fabric characteristics (such as the presence of volcanic inclusions and quartz/feldspar and an untreated coarse surface). Save for some very specific early pale pottery wares, rarely found in survey contexts, pale firing ceramics occur in larger quantities only from the later 6th century BC. Initially the pale firing fabrics of the tiles and the coarser pottery resemble those of the red firing family and stand in the late Archaic tradition (Appendix: LAV II.a). Later fabrics tend to become more depurated. In the Appendix each fabric family is split into fabric groups based on the presence and predominance of (combinations of) inclusions in the clay.

4. CONCLUDING OBSERVATIONS

The diagram presented in figure 9 shows the relation between the classified fabric groups of the Lanuvium survey and the current pottery ware groups established at Satricum. The latter furnish an approximate date range. In combination with the fabric descriptions listed in the Appendix, the diagram allows for some cautious structural observations on ceramic technology and pottery production in the rural landscape around Lanuvium in the first millennium BC.

The 'non-predominant' red firing fabrics (in which several types of inclusion are present in even quantities) relate to either Iron Age or orientaling pottery wares, such as the hand-made Burnished Brown Ware, Black Slip Ware, and Common Red Slip Ware (= *impasto rosso*). There is hardly any related tile production. The production of these fabrics will for the larger part have been dependent on household potting; this occurrence in the Lanuvium catchment signifies incipient rural infill. The increase in numbers of sherds assigned to fabrics belonging to Common Red Slip Ware indicates that the exploitation of the countryside around Lanuvium in the latter part of the 7th century BC intensified. This is especially clear in the off-site record, indicating dispersed settlements in the countryside.

The dispersed pattern crystallizes in the 6th century BC into a fairly discrete site pattern of Archaic farmsteads (fig. 4). A wide range of fabrics is now being used by the potters for the production of storage pottery, both *dolie* (large containers) and *olle* (small and medium-sized cooking and storage pots), and tiles. In this period pottery production intensified greatly and may have become organized in workshops in proto-urban centres (in casu Lanuvio) (Nijboer, 1998). A tendency towards the increased use of augite and quartz/feldspar predominant fabrics is manifest in the production of the Archaic wheelthrown Red Coarse Ware that, at the turn

of the 6th century BC, would be substituted by coarse wares of orange firing and pale firing fabrics.

At first the clays used for the orange and pale firing fabrics have quite the same composition as some of their red firing Archaic predecessors. In both families we find augite predominant and quartz/feldspar predominant fabrics that are adopted for both coarse ware pottery and tile production. In the course of the 4th century BC, however, these clays tend to be used for tile production only. In pottery production there is a tendency to use quartz/feldspar predominant clays.

In the advanced Roman Republican period the coarse wares are substituted by Common Roman Orange Ware; harder fired wheelturned pottery showing a high degree of standardization and made of well-sorted, depurated clays and found on all Roman villa terrains. This shift implies further regionalization of production.

In the Republican period lava predominant fabrics for tile production and depurated fabrics with large inclusions prevail. These are totally different from the augite and quartz/feldspar predominant fabrics used for tile production in the 5th and 4th centuries BC, which can be said to continue the Archaic tradition. We interpret this to mean that areas where this pottery is found were fully romanized.

5. NOTES

1. The ceramics were studied at the Museo Civico di Albano Laziale by Peter Attema and Gert van Oortmerssen by the kind permission of prof. P. Chiarucci during three weeks in June 1996. The initial fabric descriptions were subsequently elaborated by Gert van Oortmerssen in the laboratory at Groningen.
2. This research programme, financed by the Dutch Academy of Sciences (KNAW), was carried out by the author during the period 1994-1997.
3. The research group includes, besides the author, prof. dr. M. Kleibrink, dr. A.J. Nijboer, drs. A.J. Beijer and drs. G.J.M. van Oortmerssen.
4. This specific interest enters in yet another long term project on settlement and landscape in Central and South Italy entitled 'Regional pathways to complexity, landscape and population dynamics in early Italy'. This is a joint project of the Groningen Institute of Archaeology and the Free University of Amsterdam financed by the Netherlands Organization of Scientific Research (N.W.O.). See Attema, Burgers, Kleibrink & Yntema (1998 a and b).
5. A small portion was collected on the Tenuta Massametti, about 9 km from Lanuvium.
6. Platform villae were detected both in the Sezze survey (P.R.P. 1994), the Segni survey (P.R.P. 1997), and in the surveys carried out along the slopes of the Monti Lepini in the catchment of Norba (P.R.P. 1995). Exploitation of this kind is characteristic for the advanced period of Roman agricultural colonization and at least partly bound up with agricultural specialization (Attema, Haagsma & Delvigne, forthcoming).
7. In what follows we will, as stated in 1.3, concentrate on the classification of local *impasto* fabrics, coarse fabric and depurated fabrics having local volcanic inclusions.
8. For instance, a medium to poorly sorted augite predominant fabric in the red family LAV IE.ms-ps(1-4).ab may have an approximate counterpart in the pale family in LAV III E.ms-vps(1-4).ab.
9. Cf. my earlier observations concerning the distribution of Archaic ceramics in the Cisterna survey area located to the southwest of Lanuvium (Attema, 1993: pp. 204-210).

10. Walkers in the Lanuvium survey were spaced between 4 and 15 m apart (in 12% of the surveyed fields the spacing was 4 to 6 m, in 56% 6 to 10 m, and in 32% 10 to 15 m).
11. More than 1600 sherds were assigned to this fabric group (241 observations), of which 95% (!) was found along transects.

6. REFERENCES

- ADAMS, W.Y. & E.W. ADAMS, 1991. *Archaeological typology and practical reality: A dialectical approach to artifact classification and sorting*. Cambridge University Press, Cambridge.
- ATTEMA, P.A.J., 1993. An archaeological survey in the Pontine Region, a contribution to the early settlement history of South Lazio. Proefschrift Rijksuniversiteit Groningen.
- ATTEMA, P.A.J., 1995. Models of early Roman colonisation in South Lazio (Italy). In: *La Ciudad en el Mundo Romano*. Actas XIV Congreso Internacional de Arqueología Clásica. Tarragona, pp. 39-41.
- ATTEMA, P.A.J., 1996. Romeinse kolonisatie ten zuiden van Rome (2), de Albano survey, Italië. *Paleo-aktueel* 7, pp. 74-78.
- ATTEMA, P.A.J., B.J. HAAGSMA & J.J. DELVIGNE, 1997a. Survey and sediments in the ager of ancient Setia (Lazio, Central Italy), the Dark Age concept from a landscape perspective. *Caeculus* 3, pp. 113-121.
- ATTEMA, P.A.J., A.J. NIJBOER & G.J.M. VAN OORTMERSSEN, 1997b. Romeinse kolonisatie ten zuiden van Rome (3), het aardwerkkonderzoek. *Paleo-aktueel* 8, pp. 84-88.
- ATTEMA, P.A.J., G.-J. BURGERS, M. KLEIBRINK & D.G. YNTEMA, 1998a. Case studies in indigenous developments in early Italian centralization and urbanization: A Dutch perspective. *European Journal of Archaeology* 1, pp. 327-382.
- ATTEMA, P.A.J., G.-J. BURGERS & M. KLEIBRINK, 1998b. Centralisation, early urbanisation and colonisation in a regional context, Dutch excavations and landscape archaeology in Central and southern Italy. *Saguntum* 31, pp. 125-132.
- ATTEMA, P.A.J., B.J. HAAGSMA & J.J. DELVIGNE, forthcoming. Case studies from the Pontine region in Central Italy on settlement and environmental change in the first millennium BC. In: P. Leveau & K. Walsh (eds), *The archaeology of the Mediterranean landscape, 2: Environmental reconstruction in Mediterranean landscape archaeology*. Oxbow Publishers, Oxford, pp. 105-121.
- BETTELLI, M., 1997. *Roma. La città prima della città: i tempi di una nascita. La cronologia delle sepolture a inumazioni di Roma e del Lazio nella prima età del ferro*. L'Erma di Bretschneider, Roma.
- BOUMA, J.W., 1996. Religio votiva, the archaeology of Latial votive religion. Proefschrift Rijksuniversiteit, Groningen.
- CARAFÀ, P., 1995. *Officine ceramiche di età regia: produzione di ceramica in impasto a Roma della fine dell'VIII alla fine del VI secolo a.C.* L'Erma di Bretschneider, Roma.
- CHIARUCCI, P., 1978. *Colli Albani, preistoria e protostoria* (= Documenta Albana, V). Albano Laziale.
- CHIARUCCI, P., 1983. *Lanuvium* (= Collana di studi sull'Italia antica, 2). Paleani Editrice, Roma.
- MAASKANT-KLEIBRINK, M., 1987. *Settlement excavations at Borgo Le Ferriere <Satricum>*, I: *The campaigns 1979, 1980, 1981*. Groningen.
- MAASKANT-KLEIBRINK, M., 1992. *Settlement excavations at Borgo Le Ferriere <Satricum>*, II: *The campaigns 1983, 1985 and 1987*. Groningen.
- MACDONALD, A., 1995. All or nothing at all. Criteria for the analysis of pottery from surface survey. In: *Settlement and economy in Italy, 1500 BC-AD 1500*. Papers of the fifth Conference of Italian Archaeology (= Oxford Monograph 41). Oxford.
- Munsell soil color charts* (revised edition). New York, 1992.
- NIJBOER, A.J., 1998. From household production to workshops. Proefschrift Rijksuniversiteit, Groningen.
- SPENCE, Craig (ed.), 1990. *Archaeological site manual*, 2nd edition. Department of Urban Archaeology, Museum of London. London.

APPENDIX 1: Fabric classification and pottery forms.

1. Periodization of the Lanuvium survey material:

Iron Age	c. 850-725
Orientalizing period	c. 725-600
Archaic period	c. 600-500
Post-Archaic period	c. 500-350
Roman Republican period	c. 350-100

2. Fabric groups of the red family LAV I (date range 800-400 BC)

General comment: The date range of the wares and forms related to the fabrics of the red family of the Lanuvium survey material is by and large restricted to the period between c. 850 BC and 500 BC, although some fabrics extend into the post-Archaic period. The earliest fabrics are those listed under LAV I.a. These Iron Age fabrics have less and smaller inclusions than those of the later 7th and 6th centuries BC (late Orientalizing and Archaic period). Quantitatively group LAV I.a is almost negligible in the face of the large quantities of sherds assigned to group LAV I.c. The augite and quartz/feldspar predominant fabrics of group LAV I.c form the transition to the pale and orange firing late Archaic and post-Archaic fabrics in the fabric families LAV II and III (end 6th/5th century BC). The fabrics listed under group LAV I.b, LAV I.d and LAV I.e are late Iron Age and Archaic in date (c. 750-500 BC).

LAV I.a. Fabrics having combinations of mineral inclusions without predominance of anyone

Fabrics in this group:

+/- .ms-ps(1-3).abc (fig. 10)

+/- .ws-ms(2-3).cd (fig. 11)

+/- .ws(2-4).d (fig. 12)

Comment: The forms related to these fabrics are datable to the Iron Age and pertain to Burnished Brown Ware (fig. 11: 1, cup), Common Red Slip Ware (fig. 10: 1, jar, fig. 11: 2, base) and Black Slip Ware (fig. 12: 2, cup; fig. 12: 1, jar?). The date range of the fabrics listed seems restricted to the late Iron Age and early Archaic period. As noted above, fabric +/- .ws-ms (2-3).cd was recorded frequently in off-scatter situations and is as such indicative of the late Iron Age/early Archaic rural infill of the territory around Lanuvium (fig. 9). The forms are known from settlement contexts at Satricum (Satricum settlement phases I and II, cf. Maaskant-Kleibrink, 1992: pp. 13-14). Estimated date range of these fabrics: c. 800-700 BC.

LAV I.b. FeMn predominant fabrics

Fabrics in this group:

Q.ps-vps(1-4).b (fig. 13: 1)

Q.vps(1-4).c



AL301-05-S3

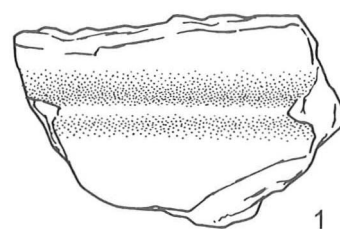

1

LAV I +/- .ms-ps(1-3).abc

Fig. 10. Plain decorated body fragment in Common Red Slip Ware.

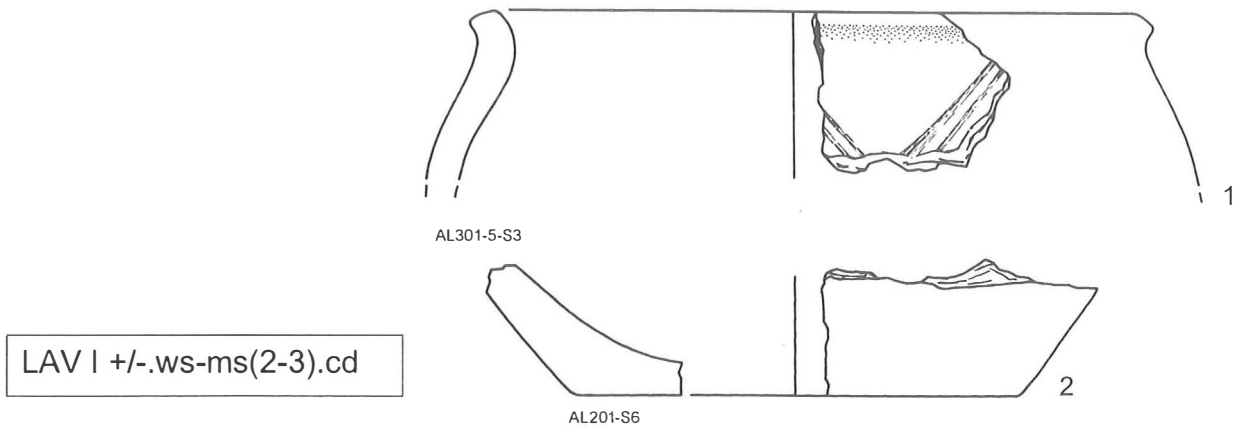

Fig. 11. Incised cup fragment in Well-burnished Brown Ware (1) and a Common Red Slip plain base fragment (2).

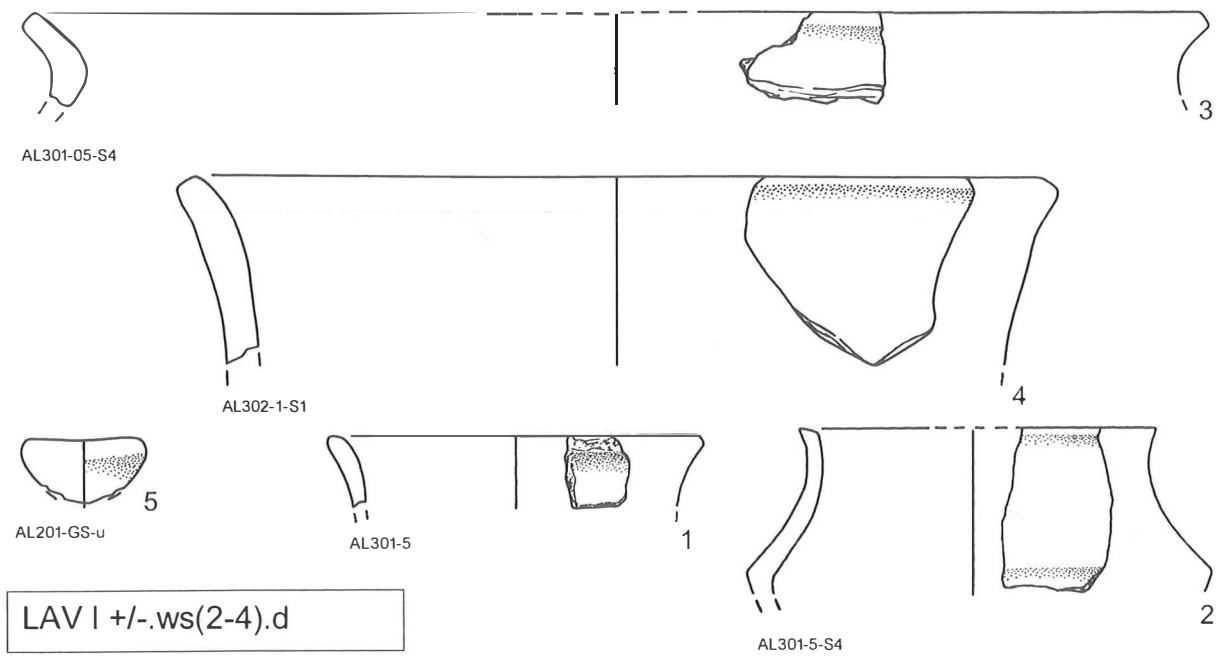

Fig. 12. Black Slip Ware rim fragments of small jar? (1) and cup (2) and Common Red Slip Ware jar fragments (3, 4) as well as a knob of a lid in Common Red Slip Ware (5).

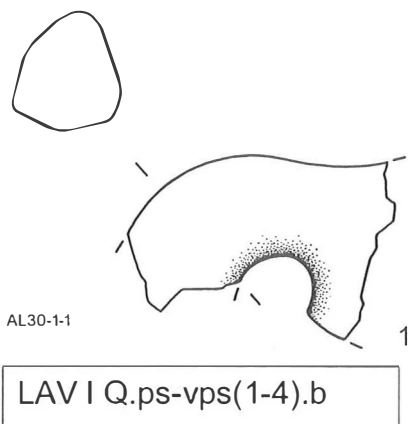
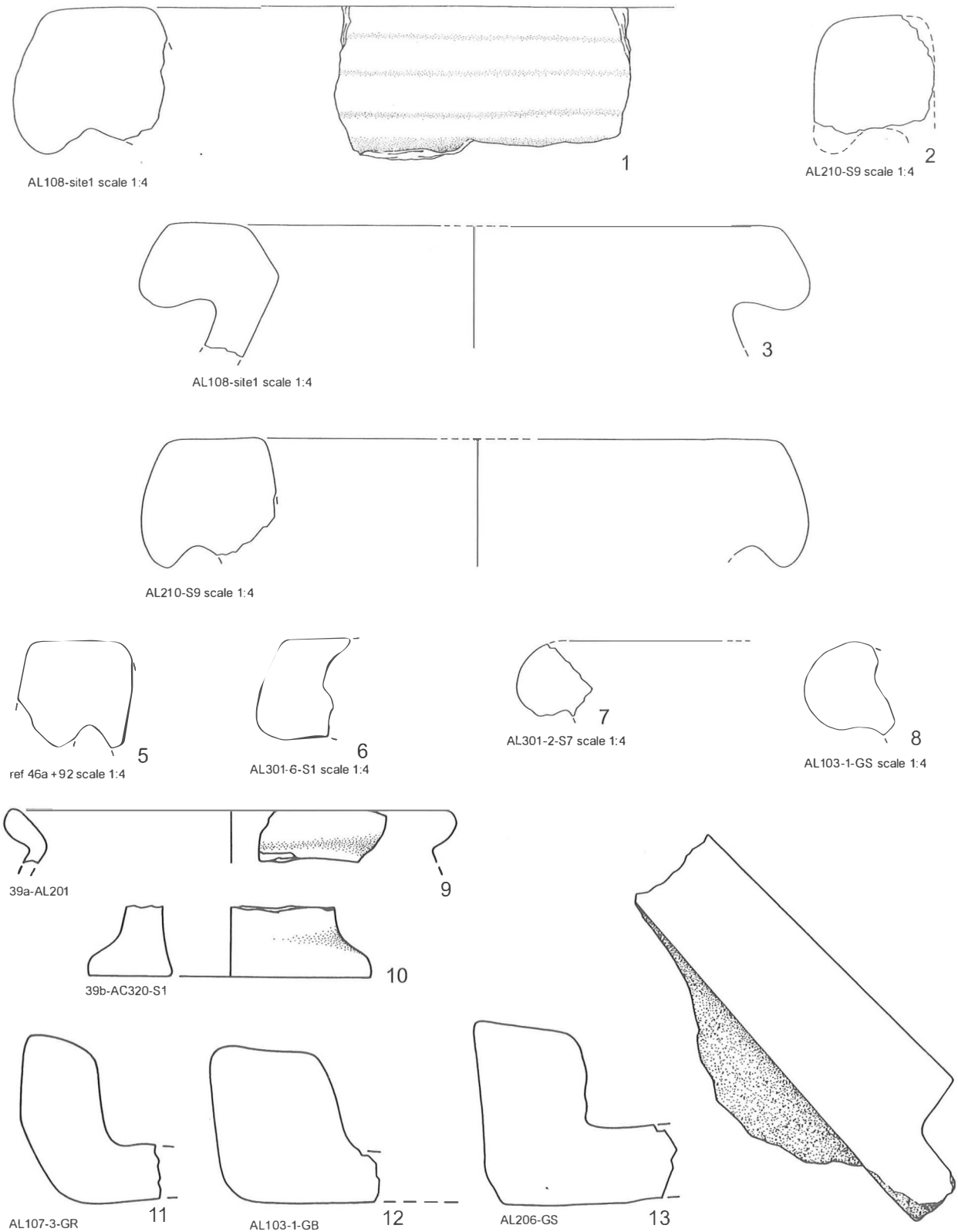

Fig. 13. Characteristic angular handle of a Common Red Slip jar, specific to this fabric.

Comment: A conspicuous fabric feature is the presence of FeMn as the predominant inclusion. It is well-visible by naked eye, as it occurs in nodules of different size. The fabric occurs in the Common Red Slip Ware group of dark red late Orientalizing/early Archaic ceramics. On part of the survey material the characteristic slip (which often appears craquelé) is still preserved. Tiles as well as pottery were manufactured in this fabric. Among the survey material is a characteristic angular handle of a medium sized storage jar. The pottery in this fabric is hand-made and was for the larger part manufactured for storage and cooking purposes. The pottery repertoire is rather restricted (predominant are, besides tiles, the so-called *ollae* or jars, though other pottery shapes occur). A total of 108 sherds were found in 33 samples ranging between 1 and 15 sherds per sample. Estimated date range: 650-550 BC.



LAV I E.ms-ps(1-4).ab

Fig. 14. Rims of large storage jars (*dolia*) of varying sizes and tile fragments in Red Coarse Ware. The fragment of a stand (10) is in Common Red Slip Ware.

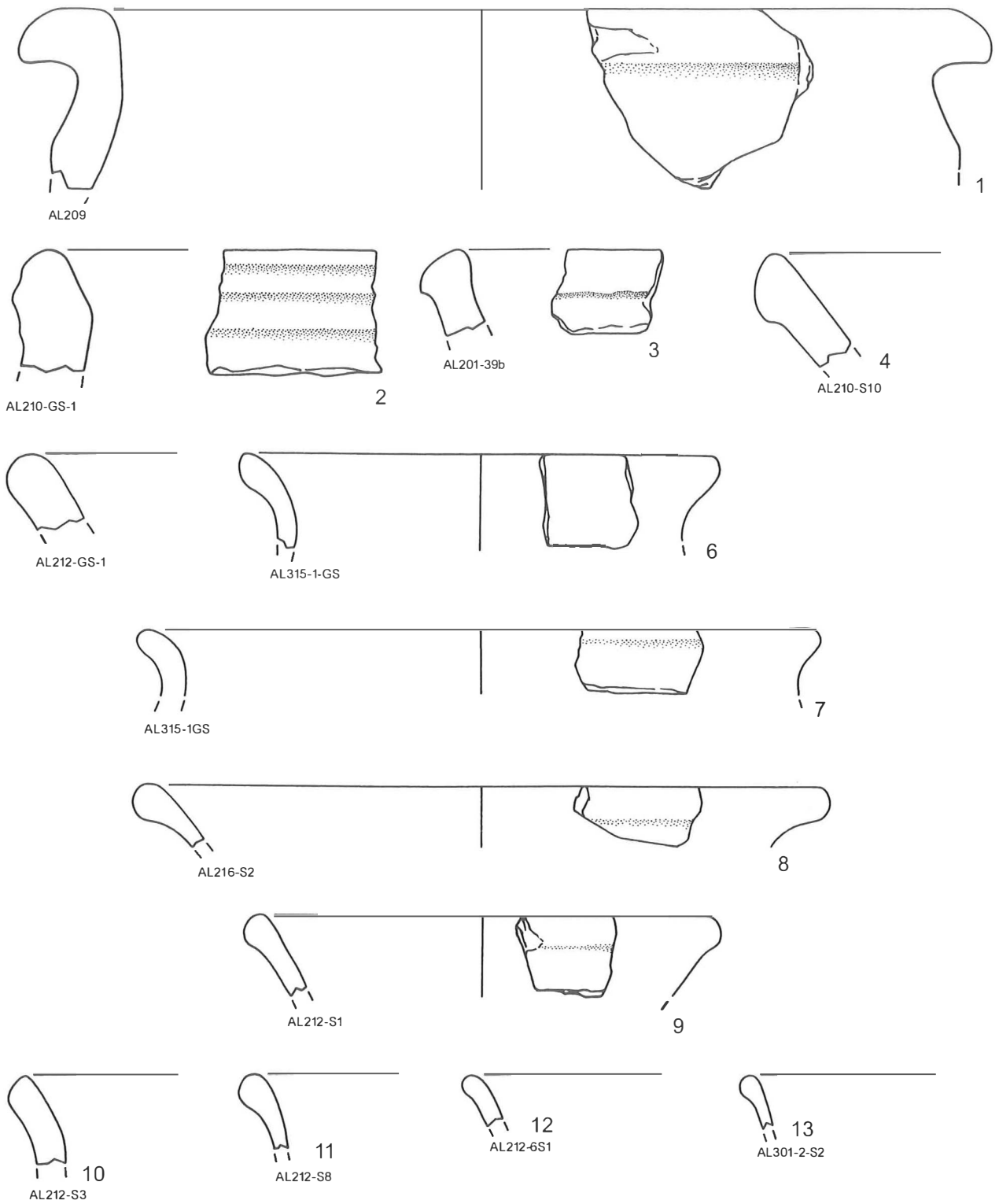

LAV I E.ms-ps(1-4).bc

Fig. 15a-d. Large and medium sized storage jars, bowls, lids, decorated wall fragments, handles and bases in Red Coarse Ware and Common Red Slip Ware. Note the fragments of votive materials on 15d (12. Fragment of uterus; 13. Fragment of a terracotta?; 14. Votive object?).

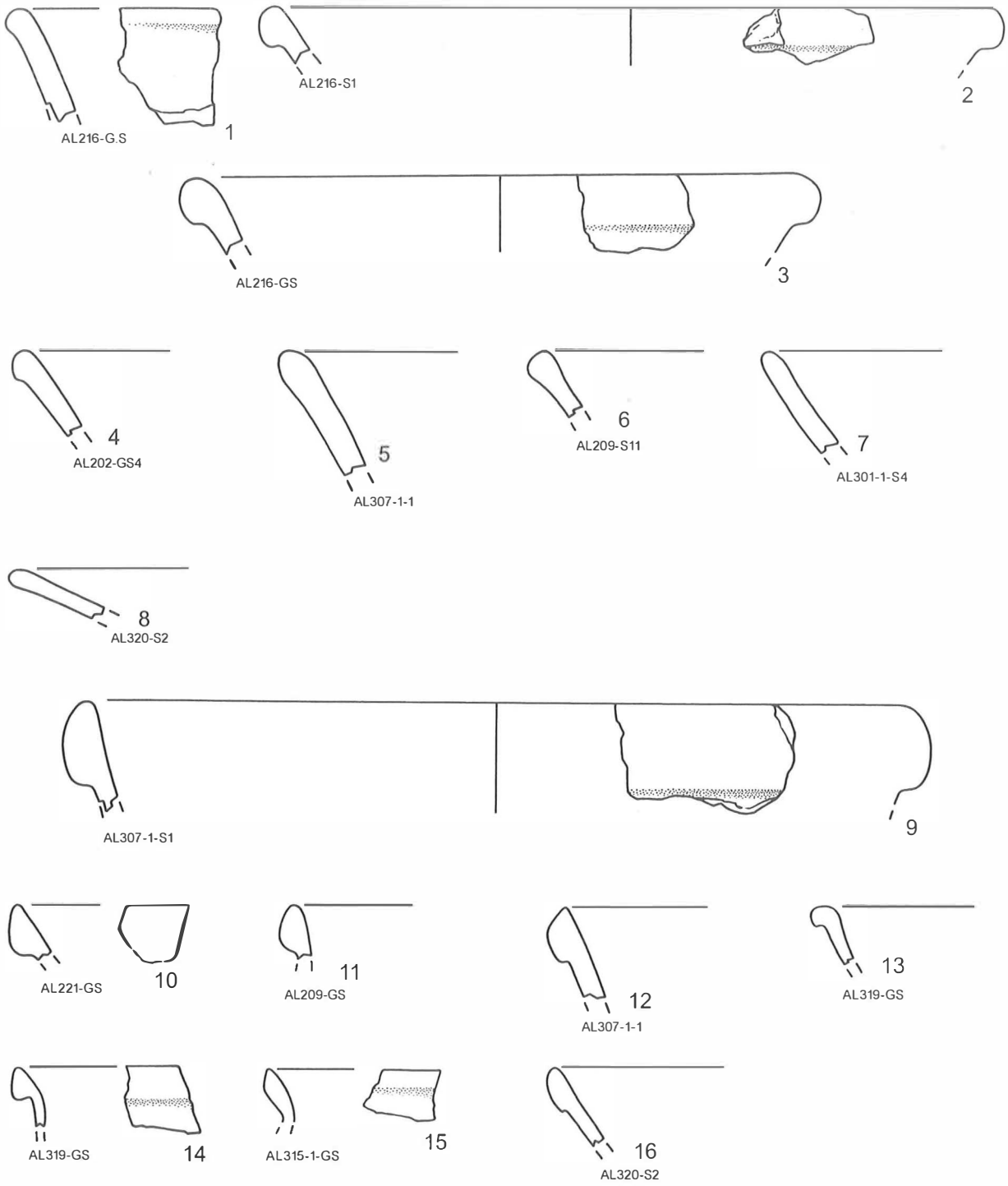

LAV I E.ms-ps(1-4).bc

Fig. 15b.

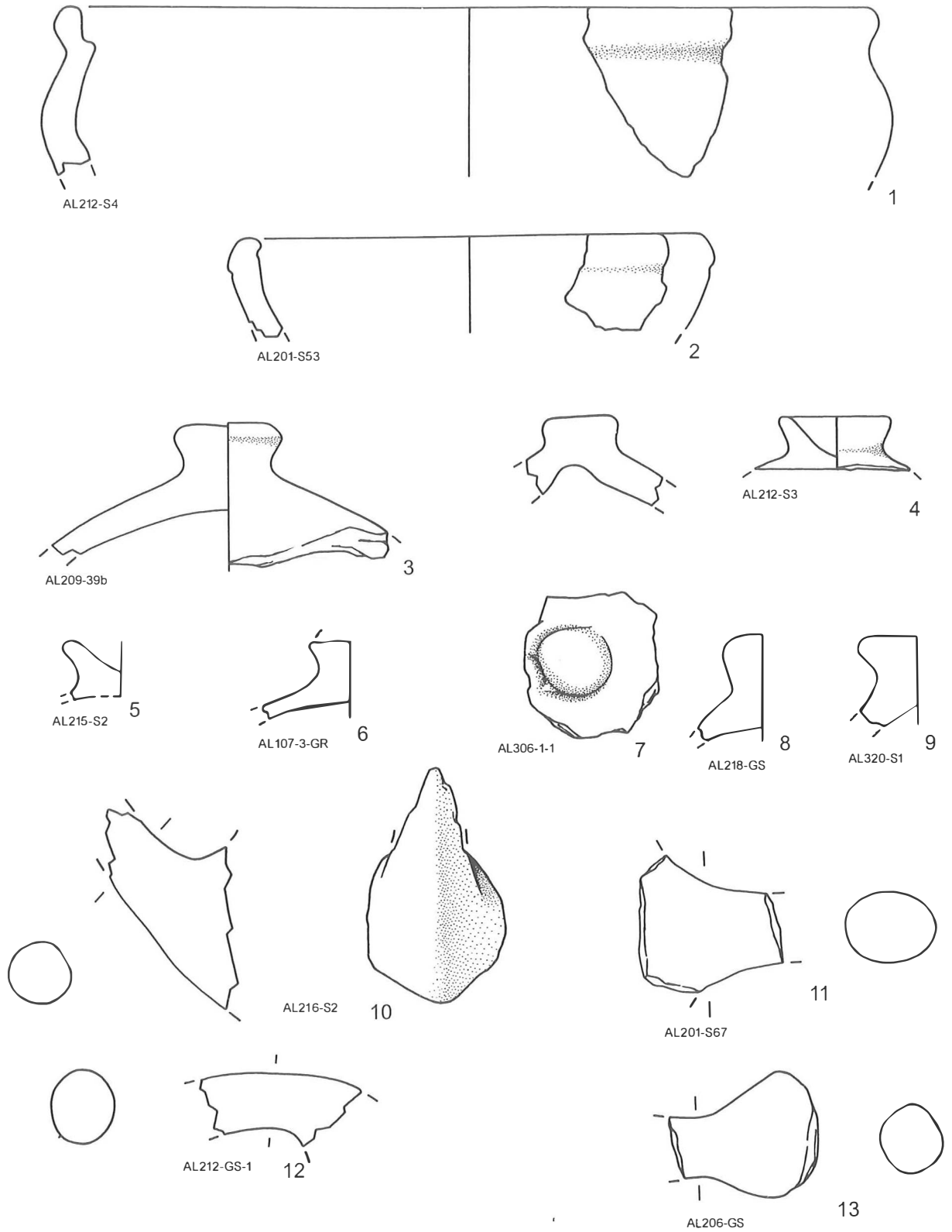

LAV I E.ms-ps(1-4).bc

Fig. 15c.

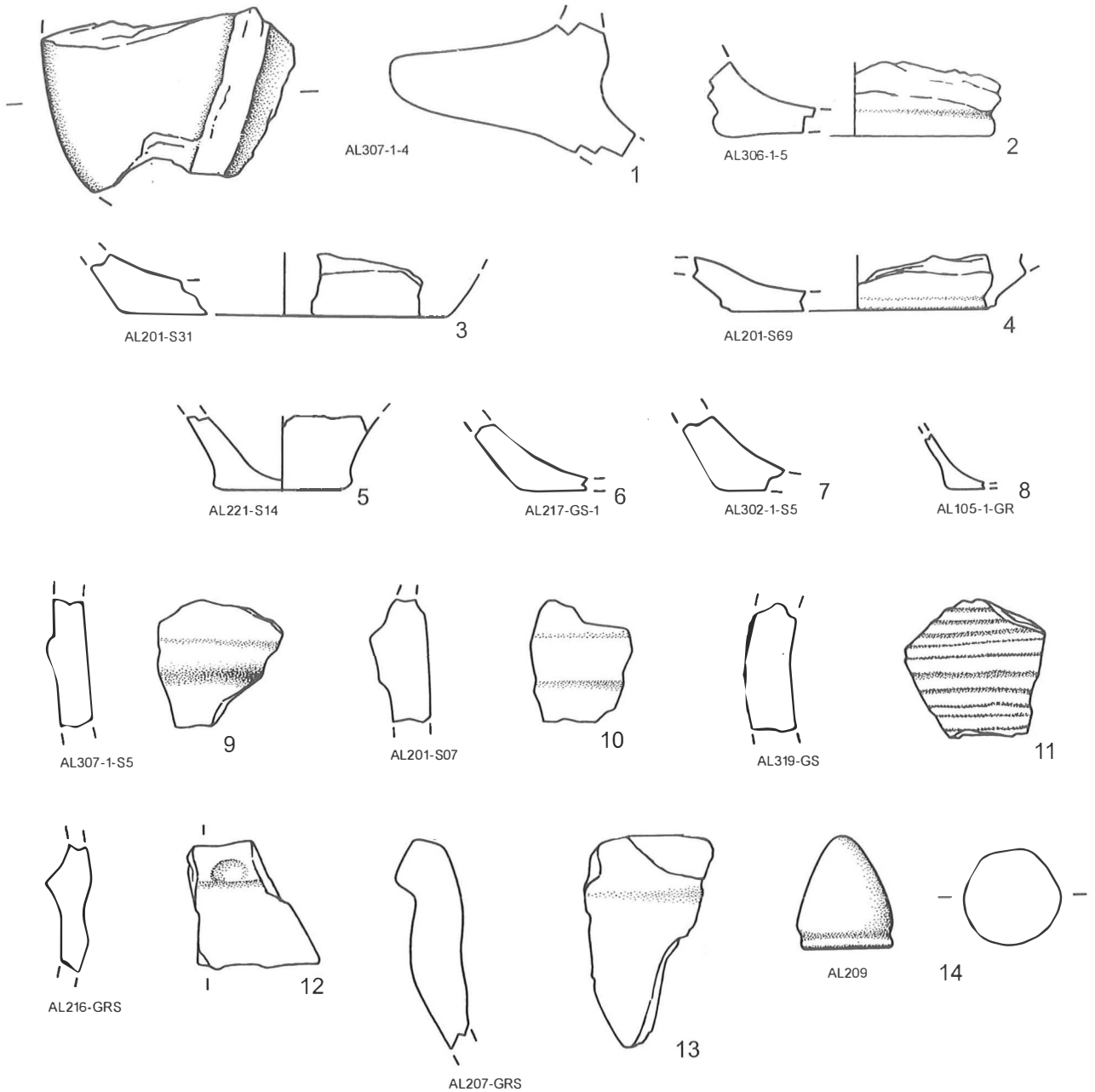

LAV I E.ms-ps(1-4).bc

Fig. 15d.

LAV I.c. Augite predominant fabrics

Fabrics in this group:

E.ms-ps(1-4).ab (fig. 14)

E.ms-ps (1-4).bc (fig. 15)

E.ws-ms(2-4).c

Comment: The two first-mentioned fabrics belong mostly to Red Coarse Ware. These proliferate in the 6th century BC, but were already present in the late 7th century BC. Some fragments, however, have clearly a thin slip preserved on basis of which they must be assigned to the late 7th century BC Common Red Slip Ware group

occurring in the late Orientalizing period (fig. 14:10, stand). Tiles, large storage jars (*doliae*), medium-sized cooking and storing jars (*ollae*), bowls, lids and plates were manufactured in these two fabrics, as well as votive material (fig. 15: 12-14). By far the larger part of the approximately 1400 fragments belongs, however, to tiles (at least 50% was identified as such). The pottery in this fabric is at first handmade and later wheelthrown. These two fabrics were observed in 192 samples. The finer variety has somewhat lesser inclusions (bc) and possibly dates later in the 6th century BC. The wares manufactured in this fabric show the transition from the Orientalizing Common Red Slip Ware to the later Archaic Red Coarse Ware. The latter is

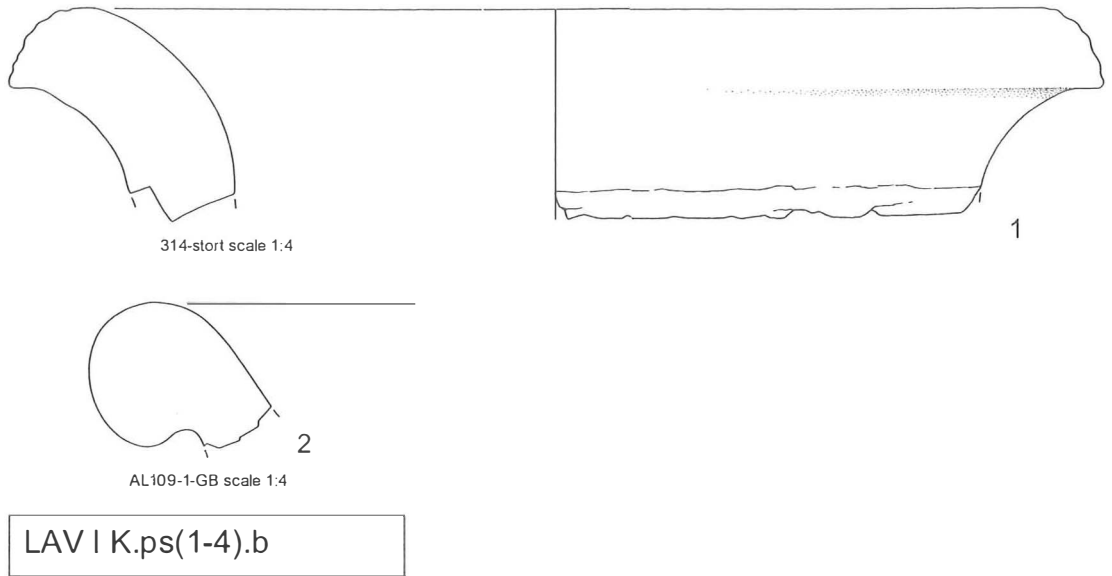

Fig. 16. Rims of storage jars in Common Red Slip Ware (late Iron Age).



Fig. 17. Body fragments with plastic decoration of medium sized jars (*ollae*) in Common Red Slip Ware

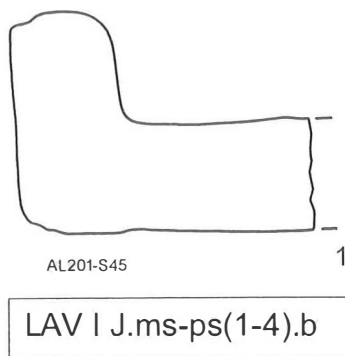

Fig. 18. Tile fragment having a surface treatment characteristic of Common Red Slip Ware

wheelthrown and its surface is mostly untreated. This fabric is the predecessor of the orange firing augite predominant fabric (see under fabric groups of the orange family LAV II). The third, much finer, fabric in this group can be related to a Fine Red Slip Ware (*impasto rosso*) that is characteristic of the Orientalizing period. It is carefully

executed. Only 10 pieces were found in 7 samples. It has a more restricted date range: between c. 725-600 BC. Estimated date range of these fabrics: 750-500/400 BC.

LAV I.d. Lavaltuff predominant fabrics

Fabrics in this group:

- a) lava predominant:
 - K.ps(1-4).b (fig. 16)
 - K.ws-ps(2-4).bc (fig. 17)
- b) tuff predominant:
 - J.ms-ps(1-4).b (fig. 18)
 - J.ms(1-4).bc

Comment: The two lava predominant fabrics in this group relate to hand-made and wheelthrown red wares, either the Common Red Slip Ware or the Fine Red Slip Ware (*impasto rosso*). The large storage jar rims (fig. 16:1, note the encircling grooves on the exterior of the rim, and fig. 16:2) are typical of storage jars of the Orientalizing period. The *bugno* decoration (fig. 17:1) and the cord decoration (fig. 17:2) are decorations applied to medium-sized *ollae*.

The tuff predominant fabrics are as the lava predominant fabrics related to Orientalizing/Archaic Common Red Slip Ware. The tile fragment in figure 18:1 received a surface treatment characteristic for Common Red Slip Ware. Estimated date range of these fabrics: 725-600 BC.

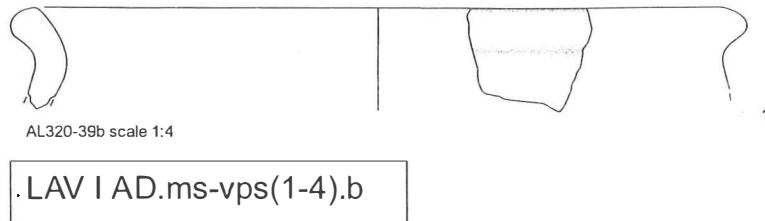

Fig. 19. Rim fragment of medium sized jar in Common Red Slip Ware.

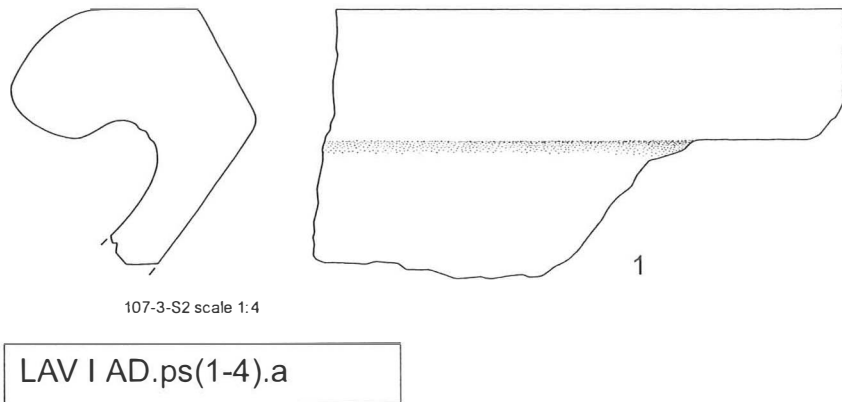

Fig. 20. Rim of a storage jar in Red Coarse Ware.

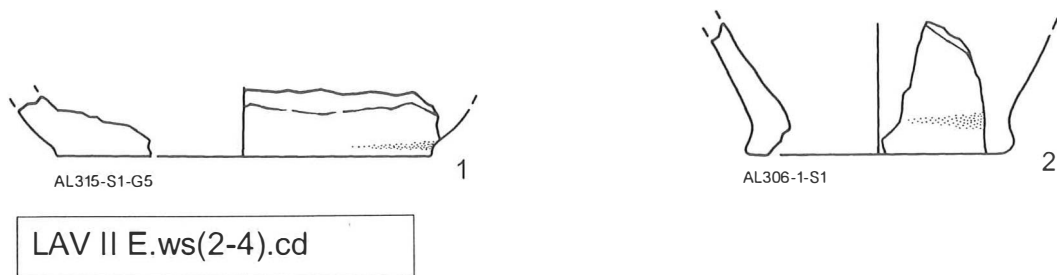

Fig. 21. Base and body fragment in Orange Coarse Ware.

LAV I.e. Quartz/feldspar predominant fabrics

Fabrics in this group:

AD.ms-vps(1-4).b (fig. 19)

AD.ps(1-4).a (fig. 20)

AD.ws(1-4).ab

Comment: The two first-listed rather coarse fabrics relate to Common Red Slip Ware or to the Red Coarse Ware, both of which proliferate in the late 7th and 6th centuries BC. Like the augite predominant fabrics this fabric continues to be used throughout the 5th and 4th centuries BC for the production of coarse ware pottery. The third-listed fabric is a finer fabric; the sherds assigned to this fabric are datable in the Iron Age/early Archaic period and relate to hand made Common Brown Ware. Estimated date range of these fabrics: 750-c. 400 BC.

3. Fabric groups of the orange family LAV II

The approximate date range of fabric family LAV II is hard to substantiate for the lack of clear stratigraphical connections. Fabric

groups LAV II.a and LAV II.b follow on the red augite and quartz/feldspar predominant fabrics. They continue the Archaic tradition. This change takes place around 500 BC. These 'traditional' fabrics are substituted in the mid-Republican period by much harder fired and more depurated fabrics (see below, group LAV II.c). The closing date of the latter production is hard to give as yet.

LAV II.a. Augite predominant

Fabric in this group:

E.ws(2-4).cd (fig. 21)

Comment: This is a fabric used for the manufacture of wheelturned coarse kitchen ware. It continues the Archaic tradition. The pottery is wheelthrown. Production probably dates to the later 6th century BC and continues in the 5th and 4th centuries BC together with the fabrics in the augite and the quartz/feldspar predominant group of the pale firing family. Of this fabric about 100 fragments were found in 60 samples. The related forms in figure 21 are, however, not very diagnostic.

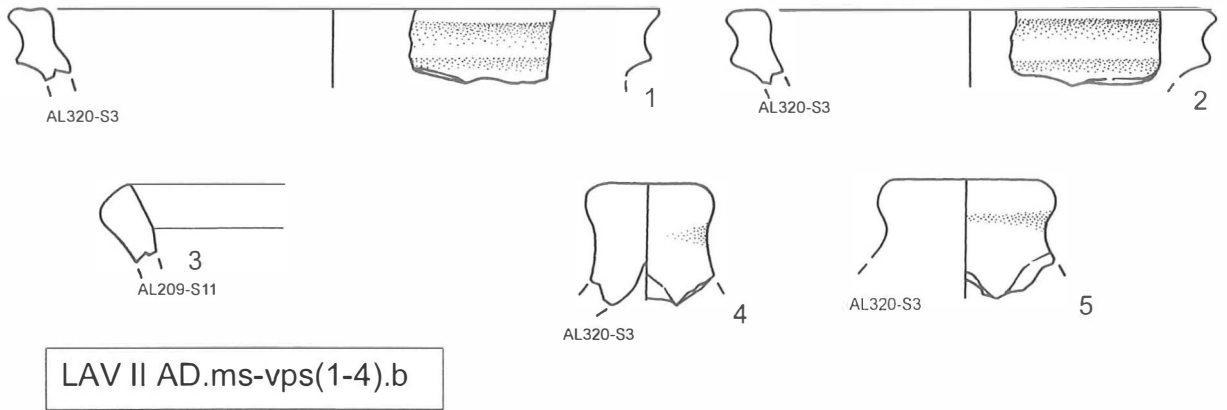

Fig. 22. Rim fragments (1-3) and knobs of lids (4-5) in Orange Coarse Ware.

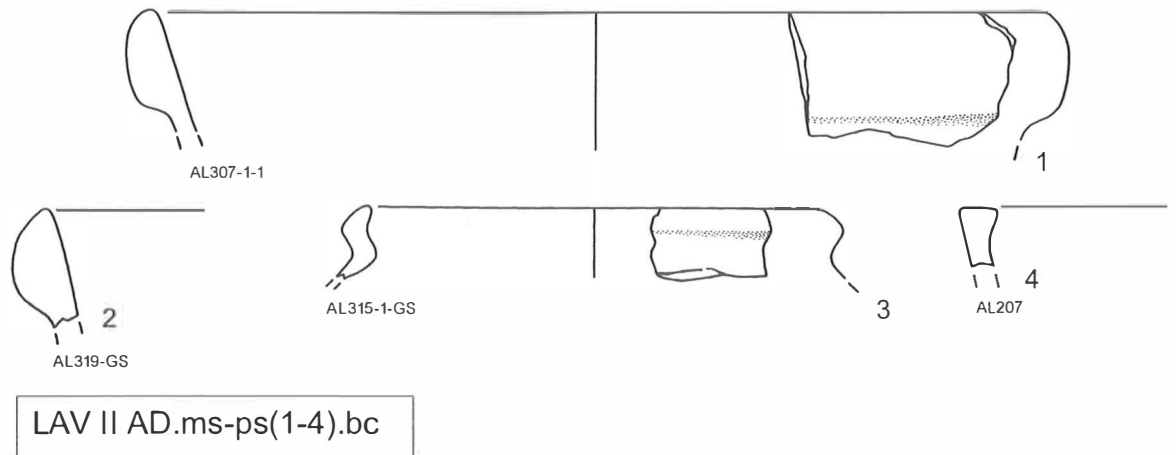

Fig. 23. Rim fragments in Orange Coarse Ware.

LAV II.b. Quartz/feldspar/auquite predominant

Fabrics in this group:

ADE.ps-vps(1-4).b, with related to this fabric:

.=ps(1-4).d, pores

Comment: These two fabrics, used for the manufacture of tiles, continue the local Archaic tradition. Production is probably restricted to the post-Archaic period. About 440 fragments were identified in respectively 39 and 68 samples.

LAV II.c. Quartz/feldspar group

Group c.1:

AD.ms-vps(1-4).b (fig. 22)

AD.ms-ps(1-4).bc (fig. 23)

Comment: These two fabrics closely resemble a fabric with like properties in the quartz/feldspar group of the red family (LAV I.AD.ms-vps(1-4).b). Like their red counterpart they are used for the manufacture of tiles and wheelturned kitchen ware. The lighter colour and the absence of surface treatment (slip), however, indicate a date for these fabrics in the post-Archaic period. Of this fabric about 250 fragments were identified in 38 samples. Almond shaped rims occur. Estimated date range between the late 6th and 4th centuries BC.

Group c.2:

AD.ws(2-4).bcd (fig. 24a-b)

AD.ws-ms(1-4).bc (fig. 25)

AD.ws(3-4).a

ADT.ws(3-4).b

ADT.ws(2-4).ab, with related to this group:

=.ws(3-4).d

Comment: These fabrics have lost all characteristics of the Archaic/post-Archaic fabrics, having almost no visible inclusions, or only a few large inclusions in a pure matrix. They replace the coarse augite and quartz/feldspar orange firing fabrics and appear in well-defined ware groups of kitchen ware with standard surface treatments. The forms are sharply wheelthrown and belong to late Roman Republican industrial production. They are found on villa sites. About 800 fragments were identified in 443 samples. Estimated date range: late 3rd century BC and later.

4. Fabric groups of the pale family LAV III

Two related groups of fabrics constitute the bulk of the pale firing ceramics that were found in the survey, viz. augite and quartz-feldspar predominant fabrics. These replace those of the Archaic red firing

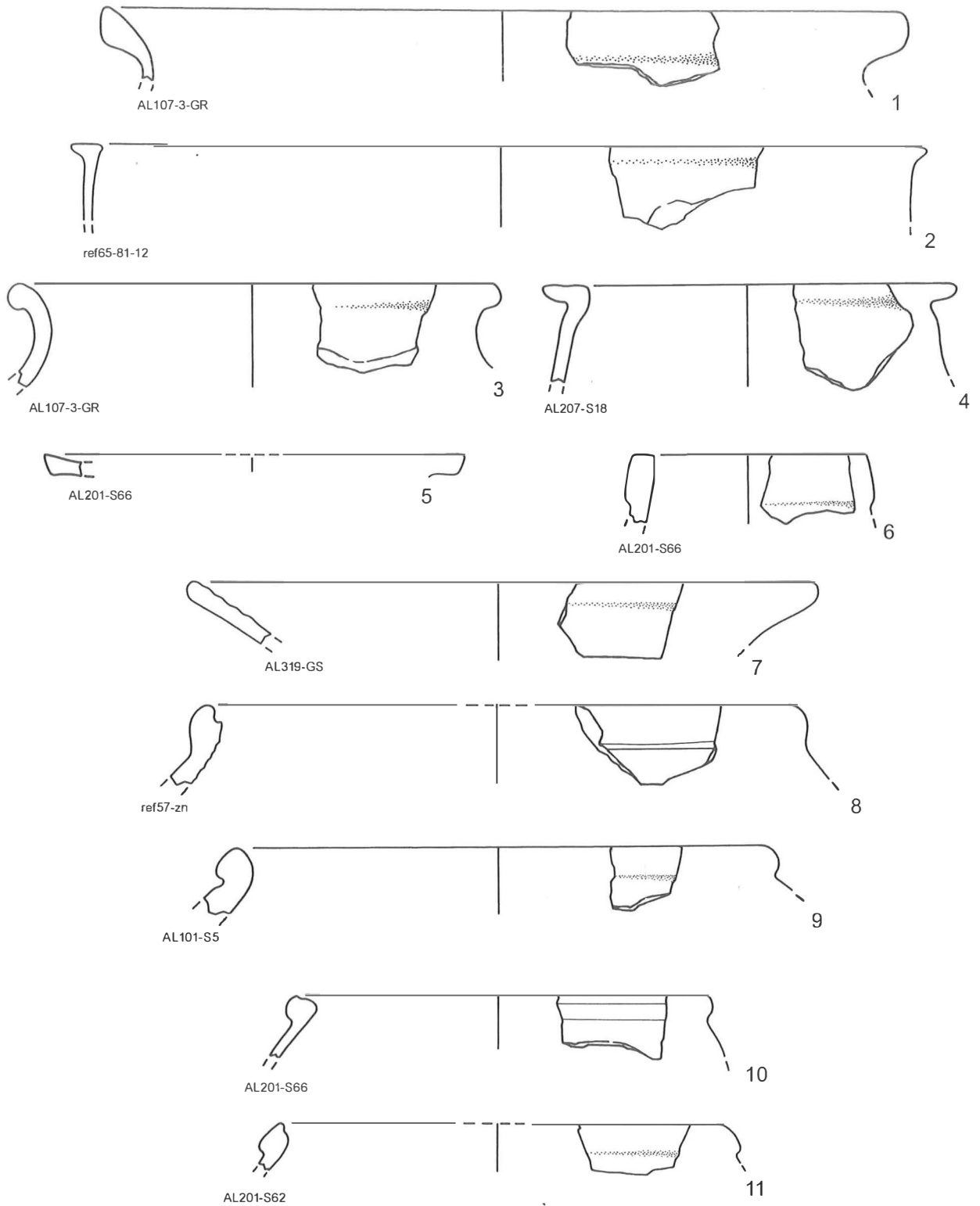

LAV II AD.ws(2-4).bcd

Fig. 24a-b. Rim fragments of medium-sized and small jars, bowls and lids in Depurated Orange Wares.

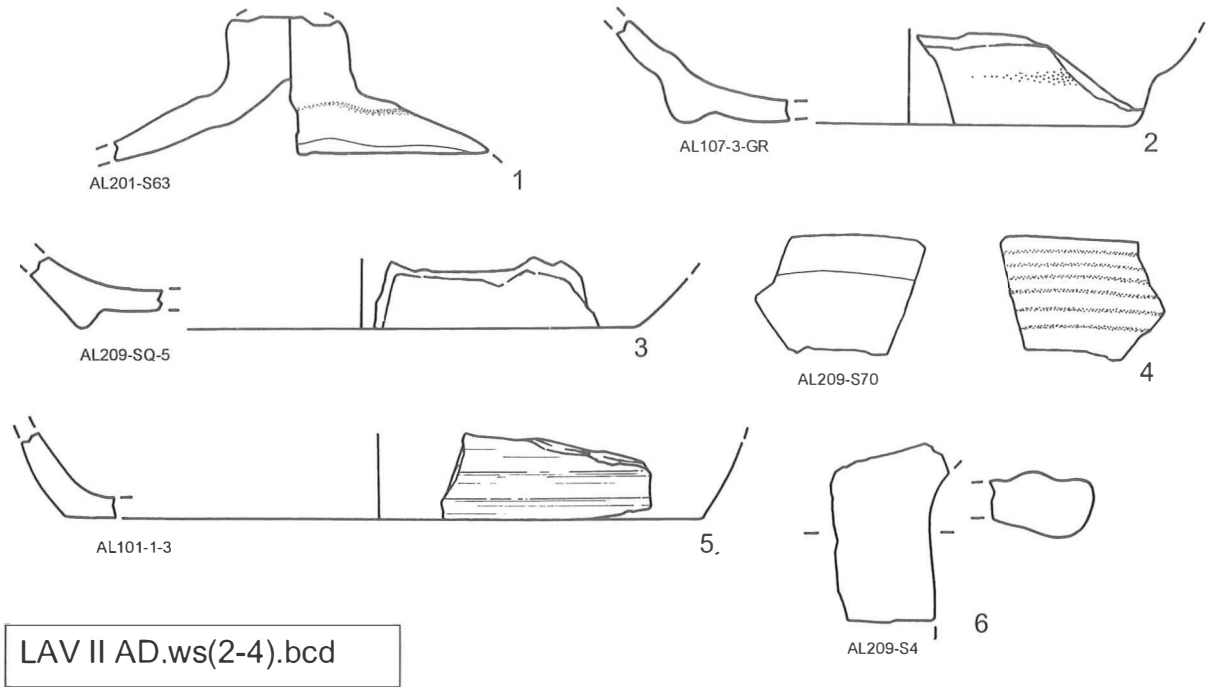

Fig. 24b.

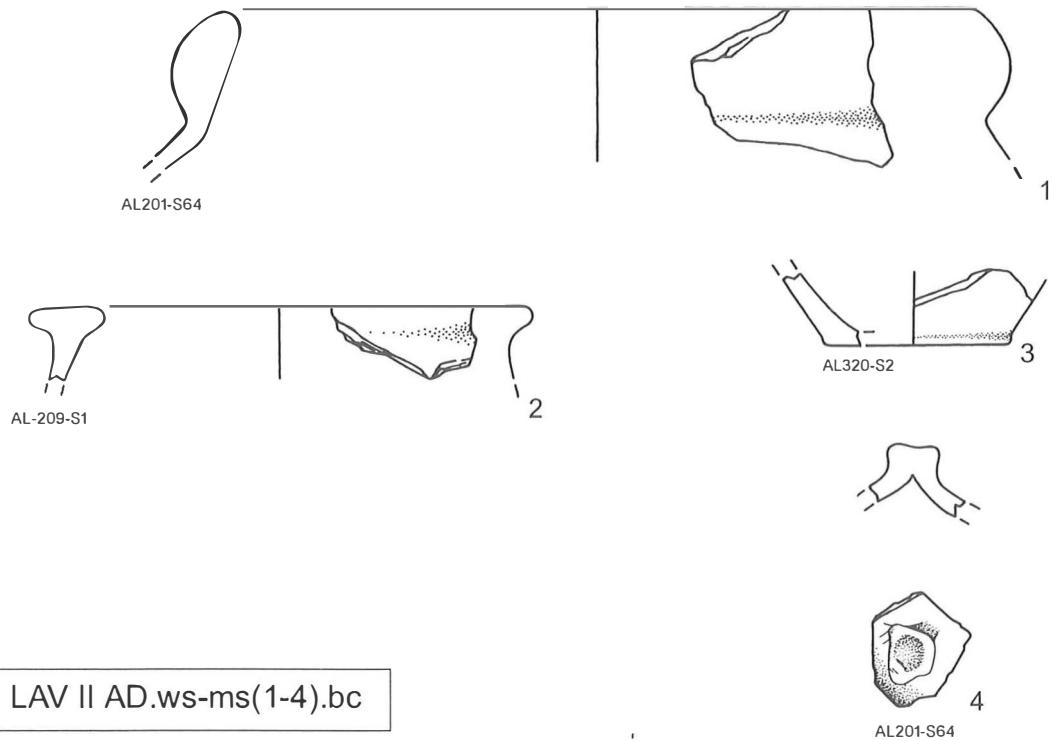

Fig. 25. Rim fragments of medium-sized and small jars, bowls, and lids in Depurated Orange Wares.

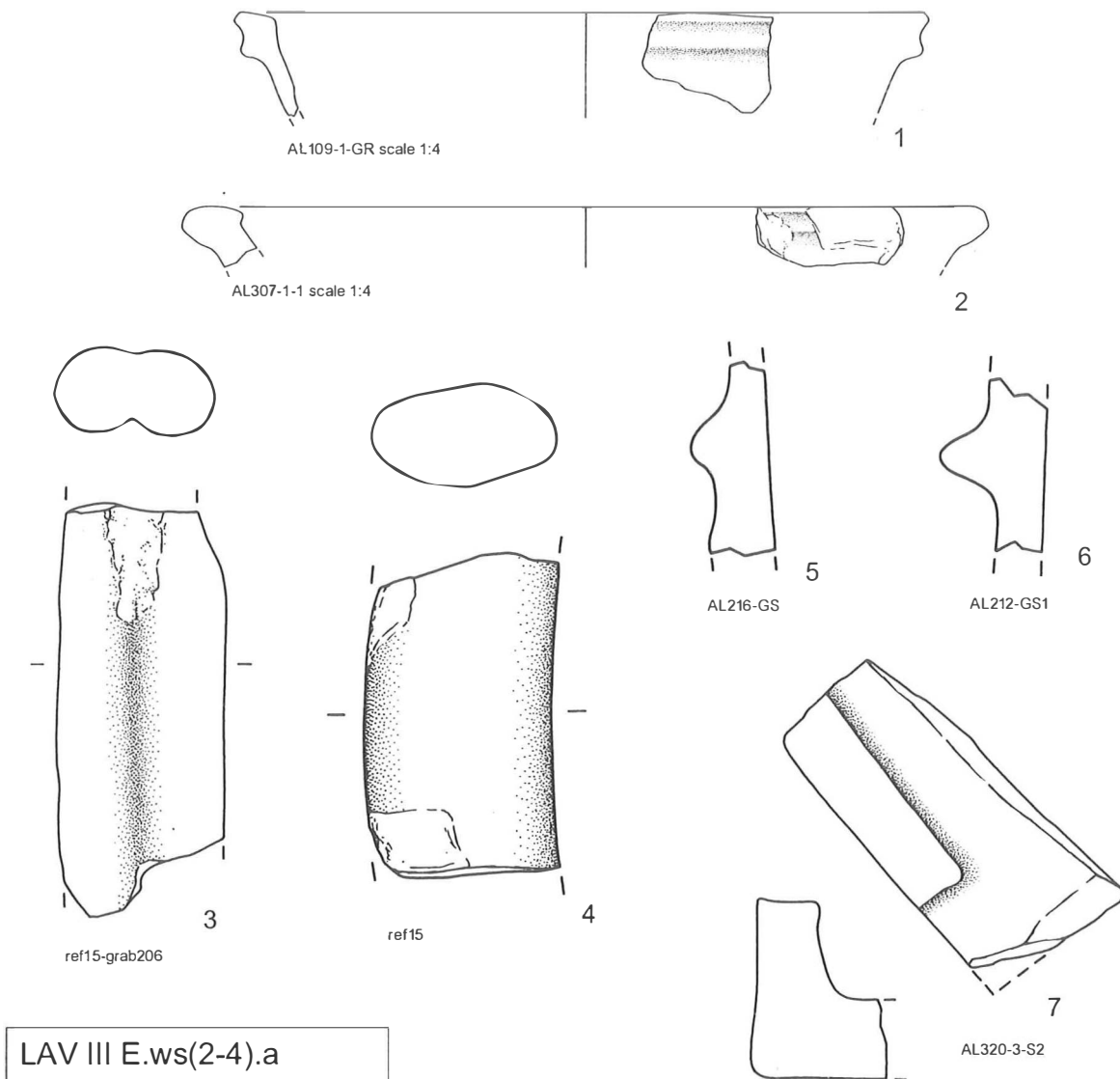

Fig. 26. Fragments of a *teglia* (large open bowl, 1), a jar (2), amphora handles (3-4), a body fragment with plastic decoration and a tile fragment (7) in a Pale Coarse Ware.

production in the manufacture of tiles and much of the storage and cooking pottery. As to mineral inclusions they still have much in common with the red firing fabrics and continue the Archaic tradition. Although pale wares occurred already at the end of the 6th century BC in Lazio, they only started to proliferate in the post-Archaic and later Roman colonial period. *Doliae*, however, continued to be produced in red fired clay besides in pale. All of the rim types presented are also known from Lavinium and date to the 5th and 4th century BC (Lavinium II).

The lava predominant group and the depurated group with large inclusions signify the end of tile production in the Archaic tradition and are, I believe, to be related to a production that is connected with the villa culture that followed on the mid-Republican period.

LAV III.a. Augite predominant group

Fabrics in this group:

E.ws(2-4).a (fig. 26)

(AD)E.ws(2-4).bc (fig. 27)

E.ms-vps(1-4).ab (fig. 28)

EK.vps(1-4).a

(AD)E.ps-vps(1-4).bc, hardness low

Comment: These augite predominant fabrics are widely found and were both used for the manufacture of tile, storage pottery as well as *amphorae*, as the bifid handle (fig. 26:3) indicates. The *teglia* rims and cords place these fabrics certainly in the 5th and 4th centuries BC ceramic production, although the production of pale firing ceramics started already in the late Archaic period. Over 1300 fragments, mostly tiles, were found in the samples. Estimated date range: 500-300 BC.

LAV III.b. Quartz/feldspar dominant group

Fabrics in this group:

ADE.ws(2-4).ab, insufficient blending

AD.ws(2-4).b

AD.ws-ms(1-3).ab

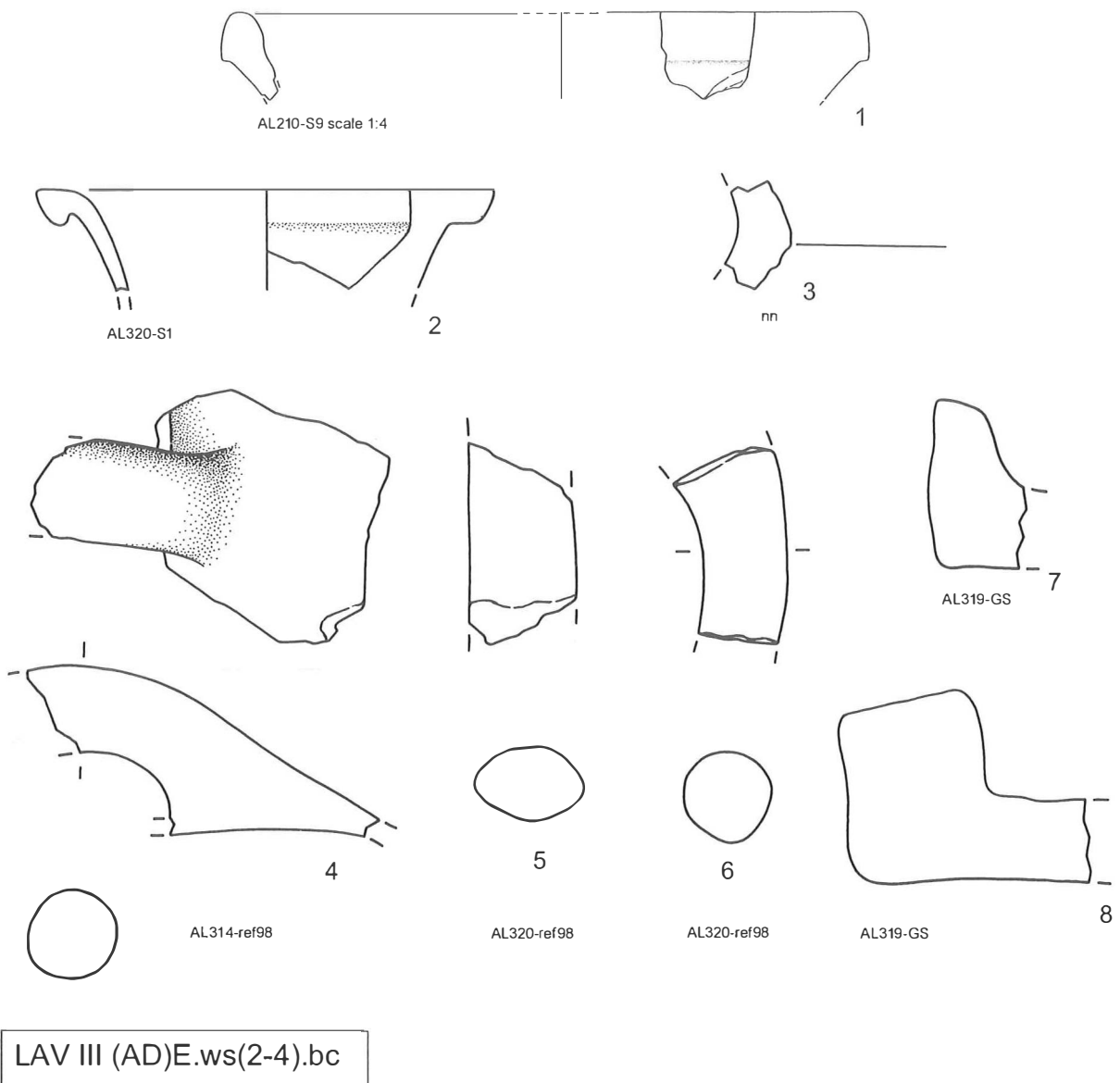

Fig. 27. Rims of a bowl (1), a jar (2), a body fragment (3), handles (4-6) and a tile fragment (7-8) in a Pale Coarse Ware.

AD.vps(1-4).a
 AD.ps-vps(1-4).b, rounded flint
 ADK.vps(1-4).bc, hard

Comment: Among the quartz/feldspar predominant fabrics in the samples, there were unfortunately no forms. Over 1900 fragments were found in 386 observations, again mostly tiles. Although the augite and the quartz/feldspar fabrics are much related, this group is less coherent. Part of the tiles made in this fabric are of a harder quality and are certainly later. Estimated date range: 400-200 BC?

LAV III.c. Lava predominant group

Fabrics in this group:
 K.vps(1-4).b
 K.vps(1-4).abc, soft (fig. 29)

Comment: This is a very typical fabric of deperated clay with large

lava particles used in the manufacture of large tiles during the late Roman Republic and early Imperial period. It is regularly found on the larger villa terrains. Over 1000 fragments were found in 181 observations. In the diagram in figure 9 they are treated as a separate group. Estimated date range: post 300 BC-100 AD

5. Deperated group having few large inclusions

Fabrics in this group:
 =.vps(1-4).d (not powdery)
 =.ps-vps(1-4).d (powdery)

Comment: These two fabrics are of deperated clay with sporadically large mineral inclusions. It was used for the manufacture of medium-sized pottery. About 250 fragments were recorded in 107 observations. Estimated date range: post 300 BC-100 AD.

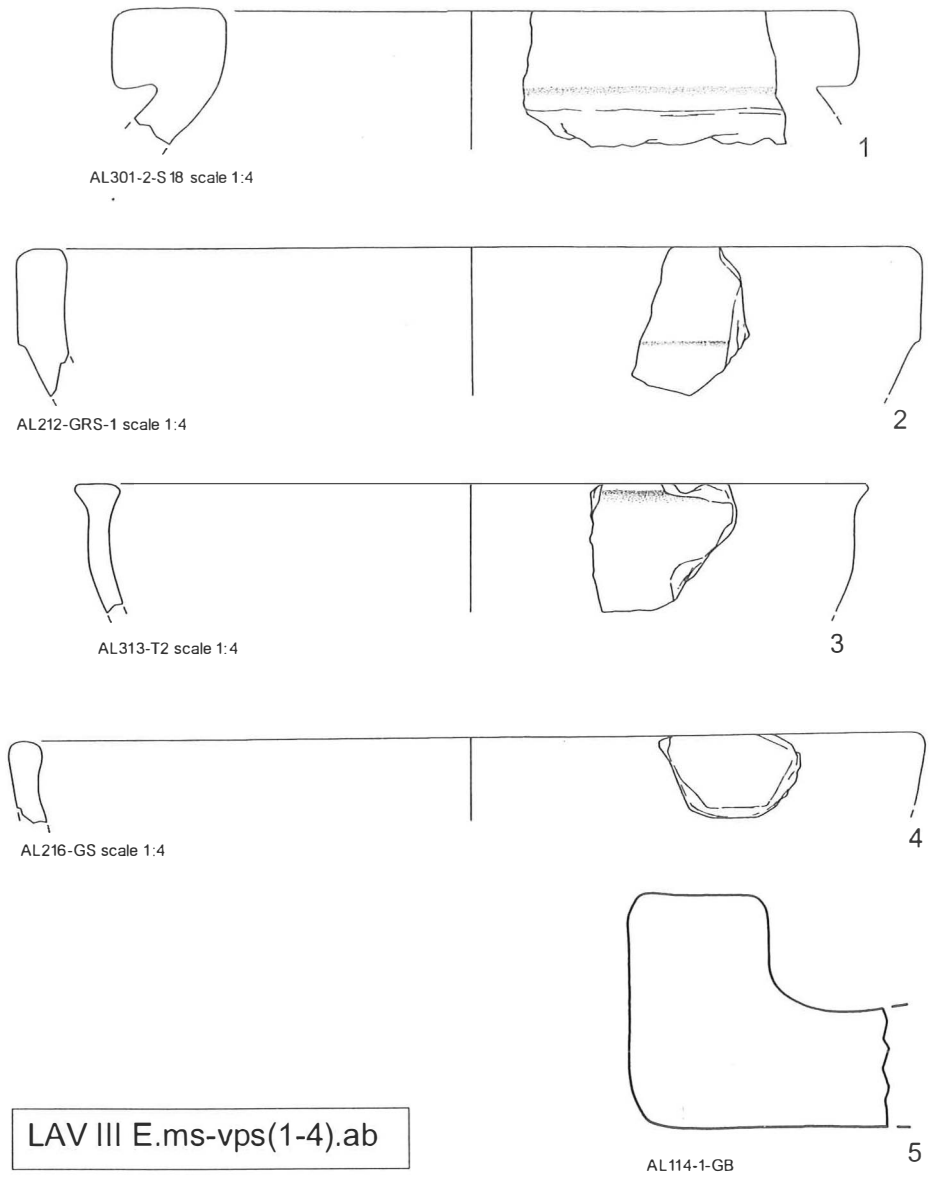

Fig. 28. Rims of a storage jar (1), bowls (2-4) and a tile fragment (5) in a Pale Coarse Ware.

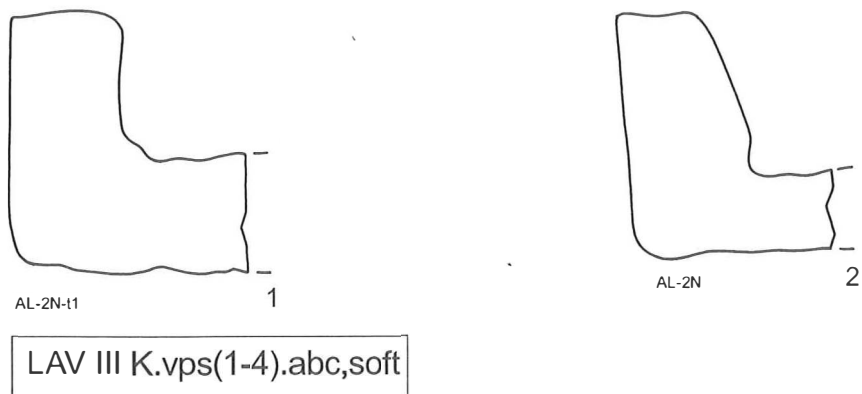

Fig. 29. Tile fragments of deperated fabric with large volcanic inclusions.