

Design of a Closed Helical Divertor in LHD and the Prospect for Helical Fusion Reactors

journal or publication title	Fusion Science and Technology
volume	56
number	2
page range	1001-1008
year	2017-04-07
URL	http://hdl.handle.net/10655/00012906

doi: 10.13182/FST09-A9041



DESIGN OF A CLOSED HELICAL DIVERTOR IN LHD AND THE PROSPECT FOR HELICAL FUSION REACTORS

Mamoru Shoji¹, Masahiro Kobayashi¹, Suguru Masuzaki¹, Akio Sagara¹, Hiroshi Yamada¹, Akio Komori¹ and LHD Experimental Groups¹

¹National Institute for Fusion Science: Toki, Gifu, Japan, 509-5292, shoji@LHD.nifs.ac.jp

A new closed helical divertor configuration for efficient particle control and reduction of the heat load on the divertor plates is proposed. The closed divertor configuration practically utilizes an ergodic layer and magnetic field line configuration on divertor legs in helical systems. For optimization of the design of the closed divertor, the distribution of the strike points is calculated in various magnetic configurations in the Large Helical Device (LHD). It suggests that the installation of the closed divertor components in the inboard side of the torus under an inward shift configuration ($R_{ax}=3.60m$) is the best choice for achieving the above two purposes. This divertor configuration does not interfere with plasma heating and diagnostic systems installed in outer ports. The prospect of the closed divertor configuration to a helical fusion reactor is investigated using a three-dimensional neutral particle transport simulation code with a one-dimensional plasma fluid calculation on the divertor legs. The investigation shows efficient particle pumping from the inboard side and reduction of the heat load due to the combined effect of the optimized closed divertor geometry, ergodized divertor legs, and low electron temperature in the ergodic layer. It indicates a promising closed divertor configuration for helical fusion reactors.

I. INTRODUCTION

The most critical issue for fusion reactors is reduction of a heat load on the divertor plates with efficient particle/impurity control in the plasma periphery. For solving the issue, closed divertor configurations are designed and experimentally investigated in many experimental devices such as Tokamaks and Stellarators, etc. A new closed helical divertor configuration which practically utilizes the three-dimensional magnetic field line configuration on divertor legs and the ergodic layer, which are intrinsic structure in the LHD plasma periphery, can solve the above critical issue by optimizing the arrangement of the closed divertor components and by

choosing magnetic configurations matching with the closed divertor configuration.

Recent plasma experiments in LHD demonstrate that peripheral plasma density control is important for achieving super dense core (SDC) plasmas with low electron temperature in the ergodic layer.¹ The closed divertor configuration can contribute to sustaining the SDC plasmas by actively pumping of neutral particles in the plasma periphery. The establishment of the operation for sustaining the SDC plasma in steady state can lead to a more attractive operational scenario in a helical fusion reactor with reduced heat load on the divertor plates.

In this paper, the optimized closed helical divertor configuration is investigated from the viewpoints of the strike point distribution and neutral particle transport. The prospect of this divertor configuration to a helical fusion reactor (FFHR) is also discussed in terms of solutions for the above critical issue.

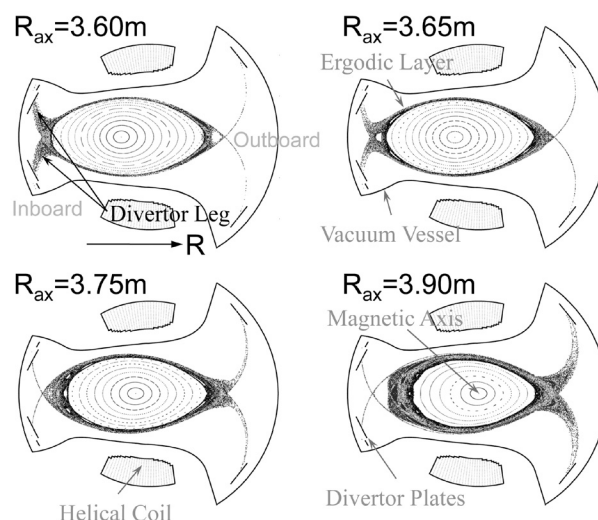

Fig. 1. Poincaré plot of the magnetic field lines in magnetic surfaces, the ergodic layer and the divertor legs in four different magnetic configurations in LHD ($R_{ax}=3.60\sim 3.90m$).

II. MAGNETIC FIELD LINE CONFIGURATION IN THE LHD PLASMA PERIPHERY

Large Helical Device (LHD) is the largest super-conducting helical machine.² The magnetic configuration for plasma confinement is produced by external two twisted helical coils and three pairs of circular poloidal coils, forming helically twisted plasma ($\ell/m=2/10$, where ℓ and m are the polarity and the field period) with no plasma currents (no large ELMs and disruptions). Non-asymmetric magnetic components produce three-dimensionally complicated magnetic structures (ergodic layer) around the last closed flux surface (LCFS). The connection length of the magnetic field lines in the ergodic layer is several km. The magnetic field lines are bundled and directly connected to the divertor plates at strike points, forming four divertor legs. The connection length of the magnetic field lines on the divertor legs is a few meter. The radial position of the magnetic axis R_{ax} is controlled by changing the coil currents of the poloidal coils, which also changes the magnetic configuration in the ergodic layer and the divertor legs. The shape of the plasma and the position of the strike points are controlled by the external magnetic field.

Figure 1 shows the Poincare plots of the plasma periphery in four different magnetic configurations ($R_{ax}=3.60\sim 3.90\text{m}$) in a poloidal cross section where the plasma is horizontally elongated. The Poincare plots indicate that the ergodic layer becomes thicker with increase in the radial position of the magnetic axis. While most of the magnetic field lines in the ergodic layer are bundled into the divertor legs in the inboard side in an inward shift configuration ($R_{ax}=3.60\text{m}$), these are connected to the divertor plate installed in the outboard side for an outward shift configuration ($R_{ax}=3.90\text{m}$).

III. CLOSED HELICAL DIVERTOR DESIGN FOR EFFICIENT PARTICLE CONTROL

Neutral particle density in the divertor region is a key parameter for the plasma density control and efficient neutral particle pumping. Measurements with fast ion gauges and estimation from an H_α intensity profiles show that the neutral density is not as high as that required for efficient particle control in the present open divertor configuration. Typical neutral pressure in the divertor region is in the order of 10mPa which is more than one order of magnitude less than the required neutral pressure. We therefore have to enhance the neutral density by more than one order of magnitude in the divertor region. Installation of closed divertor components is a possible measure for solving this issue.

The measurements with the fast ion gauges and analyses of polarization resolved H_α spectra indicate that the neutral density (hydrogen molecules and atoms) is high in the inboard side of the torus in the inward shift

configuration ($R_{ax}=3.60\text{m}$) in which the best energy confinement time has been achieved. The formation of high neutral density in the inboard side was predicted by the analyses using a fully three-dimensional neutral particle transport simulation code (EIRENE).^{3,4} There are two main reasons for this. One is that most of the strike points distribute in the inboard side in this magnetic configuration, which means main neutral particle source locates there. Another reason is the geometrical effect of the vacuum vessel on the neutral particle transport. The space between the two helical coils is narrow in the inboard side, enhancing the neutral density there.

It strongly suggests that installation of the closed divertor components in the inboard side is advantageous for further enhancement of the neutral density, which is reasonable from the viewpoint of keeping the space for particle pumping system without interferences with plasma heating and diagnostic systems installed in outboard side. We optimized the closed divertor configuration so as to increase the neutral density as high as possible by using the neutral particle transport simulation code. Figure 2 shows an image of the three-dimensional geometry of the optimized closed divertor configuration viewed from an outboard side. The closed divertor consists of the following four components:

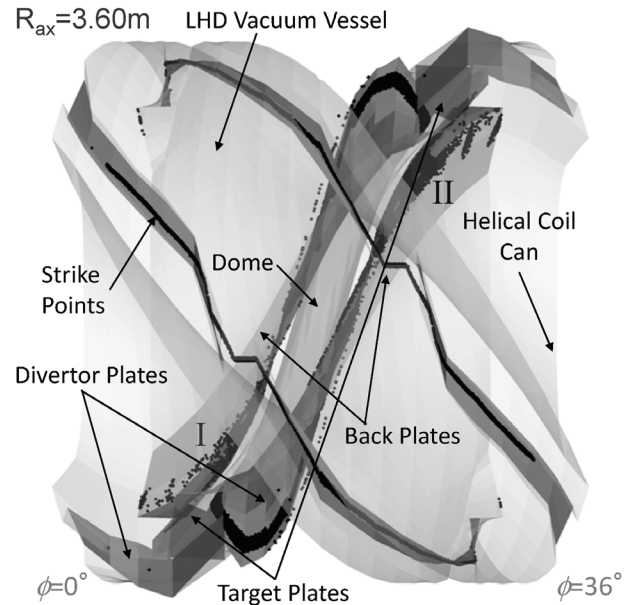

Fig. 2. Three-dimensional geometry of the closed divertor configuration for one toroidal pitch angle ($0^\circ < \phi < 36^\circ$). This figure is an image viewed from an outboard side of the torus. Small black dots along the divertor plates indicate the strike points for $R_{ax}=3.60\text{m}$.

1. *V-shaped dome which confines the neutral particles in the inboard side of the torus, and hinders penetration of neutral particles into the ergodic layer and ionization near X-points. The plasma produced by the ionization inside the ergodic layer*

moves along long magnetic field lines, which increases the peripheral plasma density. This phenomenon differs from the case of ionization in a private region near the X-points in Tokamaks in which flow in the private region push back the plasmas toward the divertor plates. We believe that the dome is an essential component to minimize the ionization of neutral particles in the ergodic layer. The neutral particles are collected behind the dome, and pumped out via a duct locating in the inboard side of the torus along the space between the two helical coil cans. The size of the entrance of the duct is enlarged as much as possible for efficient particle pumping. The space of the inside the dome can be used for a neutron shield or a tritium breeder or other engineering components.

2. *Slanted divertor plates to the inboard side such that neutral particles/impurities released from the divertor plates go toward the backside of the dome.* The arrangement of the divertor plates functions as baffles for preventing the outflow of the neutral particles from the divertor region into the main plasma. Most of neutral particles are ionized by plasmas on the divertor legs due to the small vacuum conductance between the divertor plates and the dome. Curved and strongly ergodized magnetic field line configuration on the divertor legs in the inboard side, which is an intrinsic feature in the LHD plasma periphery, is favorable not only for enhancing the neutral particle density in the inboard side but also for gaining a wide plasma wetted area on the slanted divertor plates.
3. *Back plates for protecting cooling pipes and support structures at the backside of the divertor plates from a high heat flux induced by high energy ions, etc.*
4. *Target plates vertically installed at both toroidal ends of the closed divertor components.* The plates hinder the toroidal outflow of neutral particles along the space between the two helical coils toward upper/lower ports, and change the position of strike points from the upper/lower side to the inboard side because the plates intersect the magnetic field lines on the divertor legs. The directions of magnetic field lines on two adjacent divertor legs across X-points are opposite. While magnetic field lines on a lower divertor leg are directly connect to the inboard side, magnetic field lines on another divertor legs connect to the outboard side. The shape of the target plates are designed so as to intersect only the latter divertor legs because intersection of the former divertor legs prevents enhancement of the neutral pressure in the inboard side of the torus.

An analysis by the neutral particle transport simulation code predicts that enhancement of the neutral pressure in the inboard side of the torus by more than one order of

magnitude is expected by installing these four closed divertor components for $R_{ax}=3.60\text{m}$.⁵

Investigation of the distribution of the strike points is an important first step for analyzing the effect of the closed divertor configuration. Small black dots in Figure 2 indicate the strike points calculated by tracing the magnetic field lines from uniformly distributed positions on the LCFS. A diffusion effect is included in the calculations by randomly displacing the tracing positions according to a diffusion coefficient ($D\sim 0.1\text{m}^2/\text{s}$). By using this coefficient, we can explain the experimental results of the distribution of a heat flux on the divertor plates locating along the strike points, which is measured with thermocouples embedded in the divertor plates.⁶

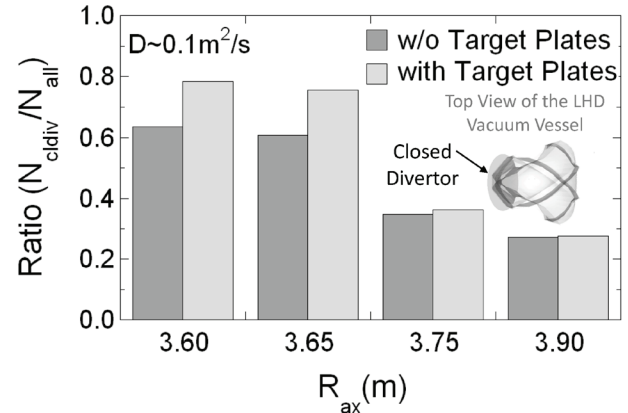

Fig. 3. Histograms of the ratio of the number of the strike points locating in the closed divertor region on that of all strike points. The ratios in the case with and without the target plates are indicated in the four magnetic configurations ($R_{ax}=3.60\text{m}\sim 3.90\text{m}$).

The ratios of the number of the strike points locating in the closed divertor region in the four different magnetic configurations ($3.60\text{m} < R_{ax} < 3.90\text{m}$) are shown in Figure 3. It gives that the ratio is about 0.8 in inward shift magnetic configurations ($R_{ax} < 3.65\text{m}$), which means that most of neutral gas sources locate in the closed divertor region. The ratio decreases when the magnetic axis is more than 3.65m, This is because the configuration of the magnetic field lines in the ergodic layer and the divertor legs is significantly changed as shown in Figure 1. The contribution to the ratio of the number of the strike points by the target plates is about 0.15 in the inward magnetic configurations. It decreases when the magnetic axis is more than 3.65m, which indicates that the effect of the target plates declines with increase in the magnetic axis position. It suggests that the closed divertor configuration exhibits the best performance in the inward shift magnetic configurations.

The distribution of the plasma flux density on the closed divertor components is qualitatively estimated by the strike point distribution. Figure 4 illustrates the distribution of the strike points locating on the closed divertor components for the four different magnetic

configurations. Strike points are more distributed on the closed divertor components in the inward shift magnetic configurations ($R_{ax} < 3.65\text{m}$) due to the strongly ergodized magnetic field line structures on the inner divertor legs.

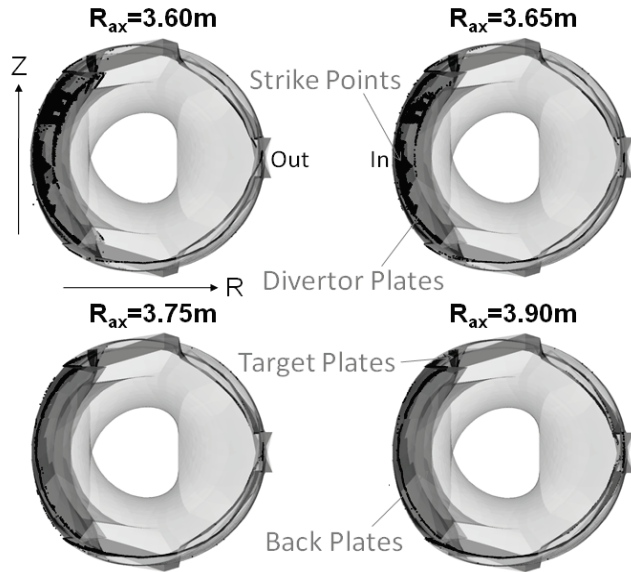

Fig. 4. The distribution of the strike points (black dots) on the closed divertor components installed in the inboard side of the torus for the four different magnetic configurations.

Figure 5 is the Poincare plots of the magnetic field lines in the plasma periphery, which include the diffusion effect, for $R_{ax}=3.60\text{m}$ in a poloidal cross section where the plasma is horizontally elongated. The cross section of the closed divertor components is also illustrated. The plasma wetted area on the divertor plates is enlarged compared to that without the diffusion (shown in Figure 1), and the width of the inner divertor legs becomes broad, which contributes to reduction of the heat flux density on the divertor plates. The closed helical divertor configuration has the following four advantages over the divertor configuration used in other devices:

1. The broad and strongly ergodized divertor legs in the inboard side for $R_{ax}=3.60\text{m}$ extend the plasma wetted area on the divertor plates, which can contribute to mitigation of the heat flux density to the divertor components. The plasma on the divertor legs prevents the outflow of the neutral particles from the divertor region to the main plasma due to ionization of neutral particles there.
2. The curved divertor legs toward the inboard side of the torus are favorable for efficient particle control/pumping from the inboard side. This is because most of neutral particles and impurities released from the divertor plates directly reach to the pumping ducts through the space between the dome and the inner wall of the vacuum vessel.

3. The ergodic layer functions as a shield against impurity penetration, which has been experimentally confirmed by comparing the measurements of carbon emission and the calculations by a three-dimensional plasma fluid code (EMC3-EIRENE).^{8,9} The long connection length of the magnetic field lines in the ergodic layer is effective for cooling down the temperature in the peripheral plasma.
4. Most of the strike points (about 80%) are directly connected to the divertor and the target plates in the inboard side for $R_{ax}=3.60\text{m}$ as shown in Figure 3, which is favorable for efficient neutral particle control. This is because we can effectively confine the neutral particles and pumped it out from the inboard side with no interference with plasma heating and diagnostic systems installed in outboard side of the torus.

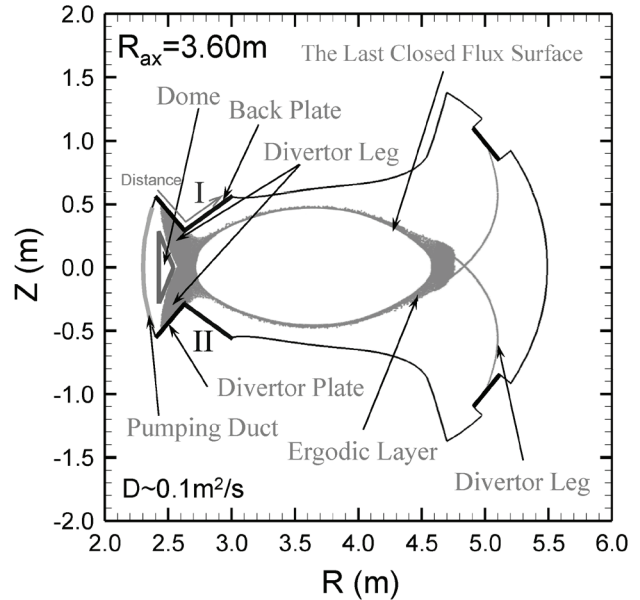

Fig. 5. Poincare plot of the magnetic field lines in the plasma periphery for $R_{ax}=3.60\text{m}$ with the poloidal cross section of the closed divertor components. The plot includes the effect of the particle diffusion ($D \sim 0.1\text{m}^2/\text{s}$).

The ergodized magnetic field line structure in the inner divertor legs diminish with increase in the radial position of the magnetic axis (see Figure 1). And, the distribution of the strike points on the closed divertor components becomes narrow in the outward shift magnetic configurations ($R_{ax} > 3.75\text{m}$) as shown in Figure 4, which means that these magnetic configurations are unfavorable for reduction of heat flux density on the divertor plates. Figures 3, 4 and 5 indicate that an inward magnetic configuration ($R_{ax}=3.60\text{m}$) is the best choice from the viewpoint of making the most of the potential of the closed helical divertor. Fortunately, the best plasma confinement time has been achieved in this magnetic configuration, indicating that operation for efficient

particle control in the plasma periphery is compatible with good main plasma confinement in LHD.

IV. NEUTRAL PARTICLE TRANSPORT SIMULATION IN THE CLOSED DIVERTOR CONFIGURATION

IV.A. Geometrical Setup for Three-dimensional Neutral Particle Transport Simulation

Neutral density profile is an essential parameter for investigating the efficiency of the particle control in the plasma periphery. We have applied the neutral particle transport simulation code to quantitative prediction of the neutral density profile in the closed divertor configuration. Parameters of neutral particles (hydrogen molecules and atoms) are calculated by tracking many test particles in a three-dimensional grid model which simulates the geometry of the vacuum vessel and the closed divertor components for one toroidal pitch angle ($0 < \phi < 36^\circ$). For this neutral particle transport simulation, we used a model of a virtual helical fusion reactor in which the shape of the plasma, the vacuum vessel and the closed divertor components is identical to that in LHD. The size of the geometry is linearly extended to a Force Free Helical Reactor (FFHR) size ($R_0=14.0\text{m}$) from the LHD size ($R_0=3.9\text{m}$), where R_0 means the major radius of the device center.¹⁰

Divertor components (divertor plates, the vacuum vessel and the back plates) are approximated as assemblies of triangular plates in the model. Because of the arbitrary shape of the target plates and the dome which crosses over some toroidal sections in the model, these two divertor components are included independently of the other divertor components by using a function ‘additional surface’ implemented in the simulation code. The entrance of the duct to the vacuum pumping system is set on the surface of the vacuum wall in the inboard side of the torus (behind the dome). Instead of adding some additional grids for simulating a duct to the vacuum pumps which make the three-dimensional grid model more complicated, we introduced a special surface for the entrance of the duct. The surface absorbs test particles with a probability which satisfy a predefined pumping speed at the entrance of the duct. Two surfaces at the both toroidal ends of the grid model are treated as a periodic surface on which the position of an injected test particle are moved to another surface, and the direction of the test particle is rotated at the one-toroidal pitch angle (36°) on the machine axis.

IV.B. Tracking of Test Particle Trajectories

The trajectories of the test particles are determined by the Monte-Carlo method including various atomic/molecular processes (charge exchange, electron

and ion impact ionization, and recombination, etc.). For simplicity, neutral-neutral collisions and the effects of the vibrational excitation of neutral hydrogen molecules are not included. Some parameters of neutral particles released from divertor plates are determined by using a database on plasma-wall interactions calculated by TRIM code. All vacuum components in the model are regarded as carbon because recent measurements with material probes show that most of vacuum components are covered with carbon deposition layers which are migrated from the divertor plates (carbon) due to sputtering by main plasma discharges and glow discharges for wall conditioning.¹¹ For analysis of the neutral particle transport in steady state operation in the closed divertor configuration, the particle reflection coefficient of the all vacuum components is set to be 1.0 (no particle absorption). The absorption probability of the special surfaces for simulating the entrance of the duct is set to be 0.01 which provides a reasonable pumping rate ($\sim 72 \text{ m}^3/\text{s}$) for the helical fusion reactor.

IV.C. Particle Source Profiles

The particle source profiles on the divertor plates and the target plates are derived from the calculated plasma parameters on the divertor legs, which include the effect of ion acceleration by the plasma sheath on the divertor plates. The parameter profiles on the divertor legs are calculated by solving one-dimensional plasma fluid equations along the magnetic field lines on the divertor legs, which is described in detail in the next sub-section. For simple analysis of neutral particle transport, we assume that only neutral hydrogen molecules are released from some points on the target plates with the direction normal to the plates with energy of a room temperature (300K). No physical and chemical erosion and sputtering of the materials on the plates are included. Many test particles (in the order of 1000000) which represent neutral hydrogen molecules and atoms are released into the three-dimensional grid model according to the particle source profiles on the divertor and the target plates.

IV.D. Calculation of Plasma Parameter Profiles on Divertor Legs

The geometry of the plasma including the ergodic layer and the divertor legs is treated as a mass of hexahedron grids in the simulation code. The plasma parameters are defined in each hexahedron grid as volume averaged values, and the spatial profile of the parameters is determined from the calculation of the EMC3-EIRENE code for the FFHR (no divertor leg version, $P_{\text{output}}=284\text{MW}$, $T_e^{LCFS}\sim 400\text{eV}$, $n_e^{LCFS}\sim 1\times 10^{20}\text{m}^{-3}$, $\Gamma_{\text{output}}=1.6\times 10^6\text{A}$), where P_{output} is the total output power through the ergodic layer, T_e^{LCFS} and n_e^{LCFS} are the electron temperature and the plasma density at the last

closed flux surface, respectively, and Γ_{output} means the total output current of the plasma flow through the ergodic layer.¹²

The calculation domain of the EMC3-EIRENE code does not include the divertor legs because the high rotational angle of the magnetic field lines on the divertor legs is not acceptable to the grid model in the code. The total current Γ_{total} is calculated under the condition that the peripheral plasma is neutralized and recycled on the surface of divertor plates installed near the X-points, which ignores the effect of the divertor legs on ionization of recycled neutral particles released from the divertor plates. We, thus, extend the calculation domain so as to include the effect of the divertor legs by solving plasma fluid equations. Following three one-dimensional differential equations (plasma density, momentum and energy) are solved along the magnetic field lines with the diffusion effect from the upstream of the divertor legs (near the X-points) to the divertor plates:

$$\frac{d(nv_{||})}{ds} = S_p, \quad (1)$$

$$\frac{d}{ds}(2nT + mnv_{||}^2) = -mv_{||} \langle \sigma v \rangle_{cx} nn_0, \quad (2)$$

$$\frac{d}{ds}(5nTv_{||} - \kappa_{||}^0 T^{2.5} \frac{dT}{ds}) = Q_{loss}, \quad (3)$$

where S_p , $\langle \sigma v \rangle_{cx}$, n_0 and Q_{loss} are a particle source rate, the rate coefficient of charge exchange, a neutral density and an energy loss via ionization calculated by the neutral particle transport simulation code, T is a plasma temperature (averaged temperature of ions and electrons), n represents a plasma density, $v_{||}$ and s are a plasma flow velocity and a coordinate along a magnetic field line, respectively, and $\kappa_{||}^0 T^{2.5}$ means a thermal conductivity.¹³ We ignored the effect of impurities in the calculation. The length of the magnetic field lines between the upstream of the divertor legs and the divertor plates are short (a few

meters), justifying that the one-dimensional plasma fluid calculation is reasonable, because the plasma transport across the magnetic field lines can be neglected.

The above three differential equations are self consistently solved using Runge-Kutta method from the upstream coupling with calculations by the neutral particle transport simulation. The equations are solved under the following boundary conditions by repeating trial and errors in order to get converged solutions:

1. three invariants (plasma source rate, momentum and energy) are conserved along magnetic field lines at the boundary between the X-points (in the calculation domain of the EMC3-EIRENE) and the upstream edge of the divertor legs (in the range of the one-dimensional plasma fluid calculation),
2. plasma flow velocity along the magnetic field lines at the divertor plates satisfies the Bohm criterion (sound speed).

For simplicity, we assume that the plasma parameters (electron and ion temperature and plasma flow velocity) inside the ergodic layer (including the X-points) are defined as the calculations of the EMC3-EIRENE code. Plasma density at the upstream of the divertor legs (near X-points) is determined by the deposition profile of the magnetic field lines on the outer edge surface of the ergodic layer and the total current of the plasma outflow Γ_{output} . The profile of the above four parameters in the ergodic layer are assumed to be constant during the iteration process for obtaining converged plasma parameter profiles on the divertor legs.

When the plasma temperature at a position on magnetic field lines in the divertor legs becomes nearly zero during the calculation of the above three differential equations, we regarded that the plasma is dissipated by the background neutral particles at the position on the divertor legs. The plasma temperature downstream from the position is regarded as zero. The neutral particles which quantity equals to that of the dissipated plasma are

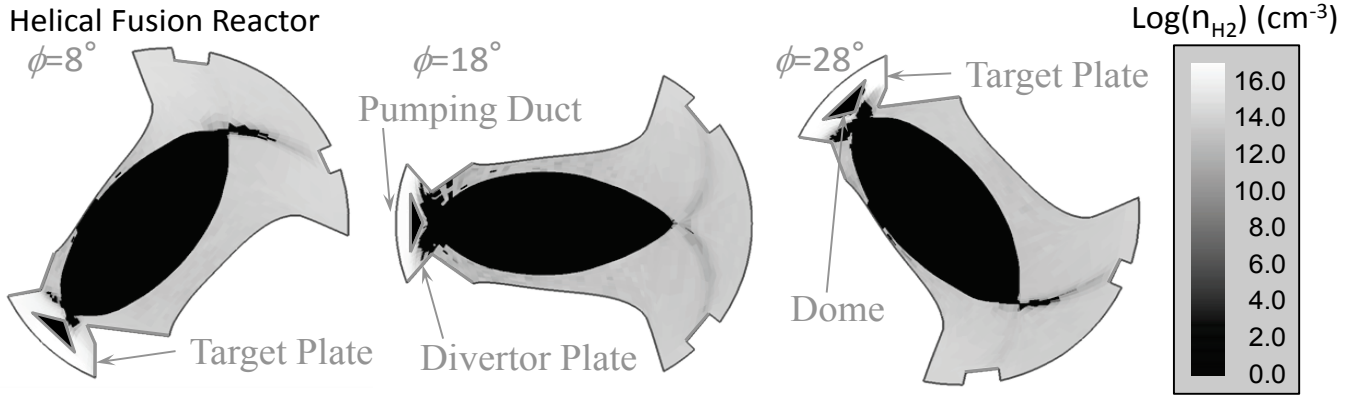

Fig. 6. Three poloidal cross sections of the density profile of neutral hydrogen molecules in the closed divertor configuration for a helical fusion reactor. The area with high density of neutral hydrogen molecules ($n_{H_2} \sim 1.2 \times 10^{16} \text{ cm}^{-3}$) is formed in the closed divertor region in the inboard side of the torus and near the target plates.

released from the strike point of the magnetic field line. Conversion of the calculations of the plasma parameter profiles along the divertor legs to the volume averaged values in the three-dimensional grid model is based on a procedure adopted in a track length estimator.

V. CALCULATIONS OF NEUTRAL DENSITY PROFILE AND HEAT FLUX DENSITY DISTRIBUTION FOR A HELICAL FUSION REACTOR

Figure 6 gives the calculations of the three poloidal cross sections of the density profile of neutral hydrogen molecules in the closed divertor configuration for the helical fusion reactor. The density of hydrogen molecules at the front of the pumping duct is about $1.2 \times 10^{16} \text{cm}^{-3}$ ($\sim 50 \text{Pa}$). Formation of the high neutral pressure at the front of the duct contributes to mitigation of the requirements of the vacuum pumping system for the fusion reactor. The neutral particle transport simulation shows that about 50% of neutral particles released from the divertor plates and the target plates directly reach the entrance of the duct, indicating that the closed divertor configuration is advantageous for efficient particle pumping. The remained neutral particles are ionized by the divertor plasmas with very low ionization in the ergodic layer near the X-points (about 2% of the released neutral particles). It indicates that plasmas produced by the ionization of the neutral particles released from the divertor plates are almost recycled in the divertor region in the inboard side. The broad divertor legs in the inboard side (shown in Figure 5) effectively contribute to efficient ionization of the neutral particles there.

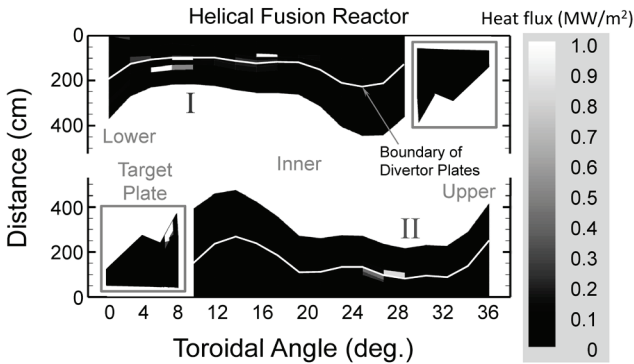

Fig. 7. Calculated profile of the heat flux density (expressed by gray squares) on the surface of the closed divertor components installed in the inboard side of the torus for the helical fusion reactor.

Figure 7 shows the calculated profile of the heat flux density on the surface of the closed divertor components (averaged values on toroidally and poloidally segmented surfaces of the divertor components), which includes the effect of the released energy of the ionization potential of hydrogen ions. The calculated heat flux on the divertor

plates is less than a few MW/m^2 which is manageable with the present heat removal systems routinely used in the large experimental devices. One reason for the strong reduction of the heat flux density is the effect of plasma energy loss by ionization of high density ($\sim 50 \text{Pa}$) neutral particles (hydrogen atoms and molecules) in the divertor region (in front of the divertor plates). Further reduction of the heat flux is expected by including plasma energy loss due to impurity radiation and some plasma-atomic/molecular interactions for detachment processes. The second reason is the low plasma temperature (about 60eV) in the outer region of the ergodic layer which is quite effective for reducing the peripheral plasma temperature and for shielding the main plasma from impurity penetration.⁹ The third reason for this is the large plasma wetted area on the surface of the closed divertor components ($\sim 60 \text{m}^2$) by the broad inner divertor legs. The ergodized magnetic field lines and the effect of particle diffusion enlarge the plasma wetted area, mitigating an excessive heat load on the divertor plates. Fine adjustment of the position and arrangement of the closed divertor components can effectively reduce the local high heat flux near the tip of the divertor and target plates shown as white squares in Figure 7.

VI. SUMMARY

A new closed helical divertor configuration, which practically utilizes the ergodic layer and the curved and strongly ergodized divertor legs, and three-dimensional magnetic field line structure on the divertor legs in the inboard side of the torus, is proposed for efficient neutral particle control/pumping and significant reduction of the heat load density on divertor plates for the LHD and a helical fusion reactor.

The analysis by magnetic field line tracing in four different magnetic configurations in LHD ($R_{ax}=3.60\sim 3.90 \text{m}$) was carried out including a particle diffusion effect and the closed divertor components. The results of the analysis are follows:

1. The ratio of the number of the strike points in the closed divertor on that of the all strike points (N_{cldiv}/N_{all}) in the inward shift configurations ($R_{ax}<3.65 \text{m}$) is about 0.6 in the case without the target plates. The ratio decreases with the increase in the radial position of the magnetic axis (R_{ax}).
2. The target plates vertically installed at both toroidal ends of the closed divertor components increase the ratio to about 0.8 in the inward shift configurations, which means that most of neutral gas sources locate in the closed divertor region. The effect of the target plates diminishes when the radial position of the magnetic axis increases, suggesting that the closed divertor configuration with the target plates can achieve efficient particle control and pumping in the inward shift configurations.

3. The distribution of the strike points on the surface of the closed divertor components in the four different magnetic configurations shows that the wide plasma wetted area in the inboard side in the inward shift configurations ($R_{ax} < 3.65\text{m}$), which means that the magnetic configurations are favorable for the heat load reduction on the divertor plates.
4. The Poincare plots in the plasma horizontally elongated cross section for $R_{ax} = 3.60\text{m}$ indicate that the divertor legs in the inboard side is broad compared to that in the other magnetic configurations ($R_{ax} = 3.65\text{m} \sim 3.90\text{m}$). The Poincare plot including the diffusion effect for $R_{ax} = 3.60\text{m}$ shows further broadening of the inner divertor legs, which is favorable for extending the plasma wetted area on the surface of the closed divertor components.

The above analysis strongly suggests that an inward shift configuration ($R_{ax} = 3.60\text{m}$) is the most advantageous for achieving the above two objectives required for the closed divertor. The functions of a closed divertor for a helical fusion reactor in which the magnetic configuration is same as that in the inward shift configuration in LHD are investigated from viewpoints of neutral particle pumping and reduction of the heat load by using a three-dimensional neutral particle transport simulation code with a one-dimensional plasma fluid calculation on the divertor legs. It indicates that;

1. The neutral pressure at the back side of the dome (at the entrance of the duct) reaches about 50Pa which is high enough for pumping out the particles supplied through the ergodic layer along the magnetic field lines (Γ_{output}) with a reasonable pumping systems for a helical fusion reactor.
2. The neutral particles are effectively confined in the closed divertor region due to the effects of the optimized closed divertor configuration and broad divertor legs in the inboard side of the torus, which contributes to efficient ionization of the neutral particles in the divertor region.
3. Besides in the inboard side, high neutral pressure ($> 50\text{Pa}$) areas are formed near the target plates, which strongly suggests that installation of additional pumping ducts near the target plates inside the closed divertor region is effective for enhancing the pumping efficiency in the helical fusion reactor.
4. Most of the plasma temperature at the front of the divertor plates and the target plates is very low because of plasma energy loss by high density neutral particles ($\sim 50\text{Pa}$) confined in the closed divertor region and the effect of the low electron temperature ($T_e \sim 60\text{eV}$) in the outer region of the ergodic layer (upstream of the divertor legs).
5. The heat flux density on the surface of the closed divertor components (divertor plates, back plates, target plates) is estimated to be less than a few

MW/m². Besides the above two effects, a reason for the low heat flux is the large plasma wetted area ($\sim 60\text{m}^2$) formed by the ergodic magnetic field lines on the inner divertor legs.

6. The local high heat flux on the closed divertor components on target plates and the tips of the divertor plates (boundary between the divertor and the back plates) can be reduced by fine adjustment of the position and shape of the closed divertor components.

We proposed a possible closed helical divertor configuration for efficient particle control/pumping with reduction of the heat load on the divertor plates for a helical fusion reactor. In this concept, the neutral particles are pumped out from ducts installed in the inboard side of the torus, which does not interfere with plasma heating systems, tritium breeder components and the other engineering devices installed in outboard side. More detailed investigation including the neutral-neutral collisions, impurity effects, updated atomic/molecular processes for plasma detachment, photon transport, etc. can lead to more favorable effects for the closed divertor configuration in the helical fusion reactor.¹⁴

ACKNOWLEDGMENTS

One of the authors (M.S) would like to thank all members of the LHD experimental groups in NIFS for their fruitful discussion on this research. This work is performed with the LHD numerical system under the auspices of the NIFS collaborative research program.

REFERENCES

1. N. OHYABU et al., *Phys. Rev. Lett.*, **97**, 05502 (2006).
2. O. MOTOJIMA et al., *Nucl. Fusion*, **40**, 599 (2000).
3. D. REITER et al., *Fusion Sci. Technol.*, **47**, 172 (2005).
4. M. SHOJI et al., *J. Nucl. Mater.*, **363-365**, 827 (2007).
5. M. SHOJI et al., *Plasma Fusion Res.* **3**, S1038 (2008).
6. H. OGAWA et al., *Plasma and Fusion Research*, **2**, 043 (2007).
7. R. KÖNIG et al., *Plasma Phys. Control Fusion*, **44**, 2365 (2002).
8. Y. FENG et al., *Plasma Phys. Control. Fusion*, **44**, 611 (2002).
9. M. KOBAYASHI et al., *Plasma Fusion Res.* **3**, S1005 (2008).
10. A. SAGARA et al., *Nucl. Fusion*, **45**, 258 (2005).
11. M. TOKITANI et al., "Quantitative analysis of plasma particles in materials exposed to LHD divertor plasmas", Proceeding 21th IAEA Fusion Energy Conference, Chengdu, China, 16-21, Oct. 2006, Paper EX/P4-27 (2007).
12. M. KOBAYASHI, et al., *Fusion Sci. Technol.*, **52**, 566 (2007).
13. P. C. STANGEBY, "The plasma boundary of magnetic fusion devices", pp.423-424, P. Stott and H. Wilhelmsson, Ed., Institute of Physics Publishing, Bristol and Philadelphia (2000).
14. A. S. KUKUSHKIN et al., *Nucl. Fusion*, **47**, 698 (2007).