



AALBORG UNIVERSITY
DENMARK

Aalborg Universitet

Development of a Modelica-based simplified building model for district energy simulations

Maccarini, Alessandro; Prativiera, Enrico; Zarrella, Angelo; Afshari, Alireza

Published in:
Journal of Physics: Conference Series

DOI (link to publication from Publisher):
[10.1088/1742-6596/2042/1/012078](https://doi.org/10.1088/1742-6596/2042/1/012078)

Creative Commons License
CC BY 3.0

Publication date:
2021

Document Version
Publisher's PDF, also known as Version of record

[Link to publication from Aalborg University](#)

Citation for published version (APA):
Maccarini, A., Prativiera, E., Zarrella, A., & Afshari, A. (2021). Development of a Modelica-based simplified building model for district energy simulations. *Journal of Physics: Conference Series*, 2042(1), [012078]. <https://doi.org/10.1088/1742-6596/2042/1/012078>

General rights

Copyright and moral rights for the publications made accessible in the public portal are retained by the authors and/or other copyright owners and it is a condition of accessing publications that users recognise and abide by the legal requirements associated with these rights.

- Users may download and print one copy of any publication from the public portal for the purpose of private study or research.
- You may not further distribute the material or use it for any profit-making activity or commercial gain
- You may freely distribute the URL identifying the publication in the public portal -

Take down policy

If you believe that this document breaches copyright please contact us at vbn@aub.aau.dk providing details, and we will remove access to the work immediately and investigate your claim.

PAPER • OPEN ACCESS

Development of a Modelica-based simplified building model for district energy simulations

To cite this article: Alessandro Maccarini *et al* 2021 *J. Phys.: Conf. Ser.* **2042** 012078

View the [article online](#) for updates and enhancements.

You may also like

- [Using Modelica to investigate the dynamic behaviour of the German national standard for high pressure natural gas flow metering](#)
M von der Heyde, G Schmitz and B Mickan
- [Modelling and simulation of SISO model prosthetic limb by Open Modelica an acausal and cyber physical modelling language](#)
Sachu Reji, Sanu K Sibichan, Varghese Lejo Raju et al.
- [Modeling of Lithium Ion Battery Using Modelica and Scilab/Xcos](#)
Sigit Arianto, Rietje Yunaningsih Yuwono and Bambang Prihandoko



The Electrochemical Society
Advancing solid state & electrochemical science & technology

242nd ECS Meeting

Oct 9 – 13, 2022 • Atlanta, GA, US

Abstract submission deadline: **April 8, 2022**

Connect. Engage. Champion. Empower. Accelerate.

MOVE SCIENCE FORWARD



Submit your abstract



Development of a Modelica-based simplified building model for district energy simulations

Alessandro Maccarini¹, Enrico Prativiera², Angelo Zarrella² and Alireza Afshari¹

¹Department of the Built Environment, Aalborg University, A.C. Meyers Vænge 15, 2450 Copenhagen, Denmark

²Department of Industrial Engineering – Applied Physics Section, University of Padova, Via Venezia 1, 35131 Padova, Italy

Corresponding author: Alessandro Maccarini, amac@build.aau.dk

Abstract. Urban Building Energy Simulation (UBES) is an efficient tool to investigate and subsequently reduce energy demand of urban areas. Nevertheless, UBES has always been a challenging task due to the trade-off between accuracy, computational speed and parametrization. In order to reduce these computation and parameterization requirements, model reduction and simplification methods aim at representing building behaviour with an acceptable accuracy, but using less equations and input parameters. This paper presents the development and validation results of a simplified urban simulation model based on the ISO 13790 Standard and written in the Modelica language. The model describes the thermo-physical behaviour of buildings by means of an equivalent electric network consisting of five resistances and one capacitance. The validation of the model was carried out using four cases of the ANSI/ASHRAE Standard 140. In general, the model shows good accuracy and the validation provided values within the acceptable ranges.

1. Introduction

About half of the world's population lives in urban areas, and this share is projected to reach 60% by 2030 [1]. Cities account for a large share of global greenhouse gas (GHG) emissions, mainly due to energy services required for heating, cooling and lighting of buildings. Therefore, assessing the energy performance of buildings at urban scale represents a valuable methodology to mitigate the GHG emissions of the built environment.

Urban Building Energy Simulation (UBES) is an efficient tool to investigate and subsequently reduce energy demand of urban areas. One technique used in UBES is steady-state or quasi-static calculations. Static calculations can be carried out for different time scales using linear equations for heat transfer as a function of the thermal transmittance and temperature difference between indoor and outdoor [2]. Static calculations are fast, but on the other hand, building dynamics in terms of thermal mass are not considered.

One possibility to perform dynamic analyses at urban scale is to use Building Energy Simulation (BES) tools, which are dedicated tools for single building simulations. Mastrucci et al. [3] defined 16 building types out of 300,000 buildings in Rotterdam, Netherlands, and simulated these 16 buildings with the BES software EnergyPlus. The results were then aggregated for the whole city. Palme et al. [4] developed a new methodology to perform urban energy simulations using the software TRNSYS with



the climate model ‘Urban Weather Generator’ (UWG). The integrated methodology was applied to a case study in Kuwait. Generally, BES tools show good results in terms of accuracy, however, they require high computational efforts and a high number of input parameters. This makes such tools often unsuitable for the modeling and simulation of large districts with many buildings and few available data. To this end, UBES needs to find a good trade-off between accuracy and computational speed.

In order to reduce these computation and parameterization requirements, model reduction and simplification methods aim at representing building behavior with an acceptable accuracy, but using less equations and input parameters. Low-order thermal building models rely on an analogy between electrical and thermal physical domains. They are often referred to as $xRyC$ models, where x is the number of thermal resistances and y the number of thermal capacitances of the equivalent electrical circuit [5]. The number and configuration of resistances and capacitances can vary, depending on the required accuracy and simulation speed. Low-order models are relatively easy to solve and they can model the dynamic behavior of buildings. Thus, low order thermal network models seem to be a promising approach for urban energy simulations.

This paper presents the development and validation results of a simplified urban simulation model based on the ISO 13790 Standard [6] and written in the Modelica language. The use of Modelica not only enables the calculation of heating and cooling demand in buildings, but it also gives the opportunity to couple models of buildings and district networks in a single comprehensive model.

2. ISO 13790 thermal model network

International Standard ISO 13790 [6] reports the calculation procedure to evaluate heating and cooling energy use in buildings. The simple hourly methodology described in the latter provides a model representing the building through an equivalent electrical network (or thermal network). As previously mentioned, this modeling technique consists in representing the thermal response of the building envelope throughout equivalent resistances (R) and capacitances (C), accounting for heat transfer and heat storage phenomena, respectively. Depending on the purposes and assumptions, many thermal networks have been proposed in the literature, however the ISO 13790 model, consisting of 5 resistances and 1 capacitance (namely $5RIC$), is still used for its simplicity, replicability, and few requirements of input parameters. Figure 1 (left) shows the scheme of the $5RIC$ network, while Figure 1 (right) illustrates the Modelica model of the ISO 13790 thermal network, which was developed using models of the *Modelica Standard Library* and the *Modelica IBPSA Library* [7].

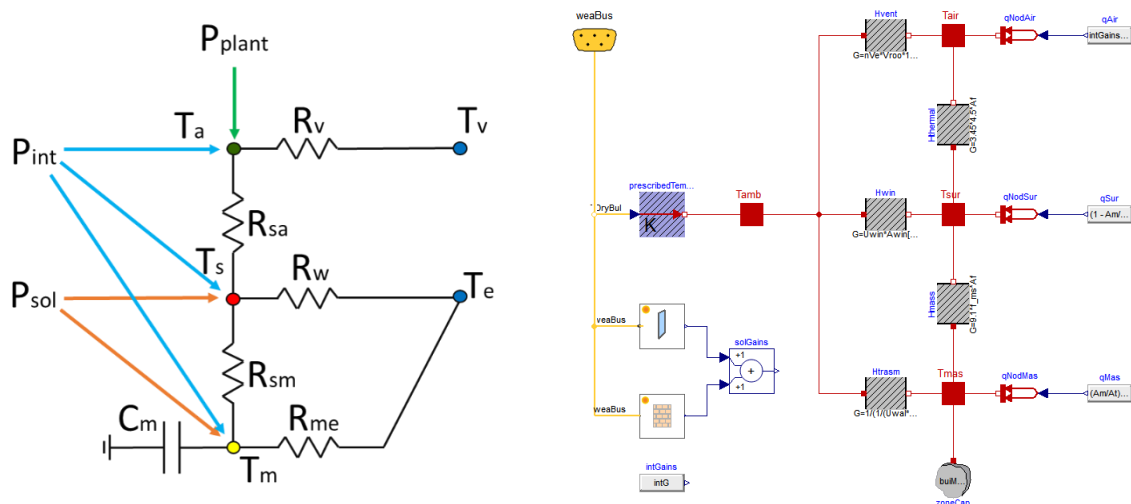

Figure 1: ISO 13790 thermal network (left). Modelica model (right).

The network is composed of three temperature nodes, representing respectively: T_a the internal air temperature of the thermal zone, T_s the surfaces internal side temperature, and T_m the temperature of structure thermal mass. As it can be seen, internal air, inside surfaces and structure mass temperatures are considered homogenous within the building geometry (zero-dimensional model). Resistance R_{sa} connects node T_a and T_s and it is calculated as the reciprocal of the product between surfaces area and internal side convective heat exchange coefficient. Additionally, resistance R_m is calculated as the reciprocal of the sum of all external opaque surfaces' U-value multiplied by their area, and further it is split into R_{sm} and R_{em} depending on structure specific mass. Heat exchange through glazed surfaces is modeled with resistance R_w and ventilation mass flow rate is used to calculate the remaining resistance R_v . Thickness, specific heat, and density of opaque structures' materials are combined using the Standard's equations to calculate the capacitance C_m , accounting for the building thermal inertia. The remaining symbols represent all boundary conditions; in particular, T_v and T_e are the ventilation supply air temperature and the external dry bulb temperature respectively, P_{int} is the heat flow rate from internal heat gains, P_{sol} is the solar heat gain. The latter is calculated considering both the solar heat gain absorbed by opaque surfaces and the solar gain entering through each window.

3. Validation

This section illustrates the validation of the Modelica ISO 13790 model using different cases of ANSI/ASHRAE Standard 140 [8], whose BESTESTs (Building Energy Simulation TEST) are widely used in the building simulation community for testing the accuracy of building energy models. Typically, a validation process consists of a comparison between simulated and measured values. However, measuring the energy performance of a building for one year is a complex and costly task. As an alternative approach, the BESTEST procedure consists of analytical techniques and tests to be carried out for the comparison of the simulation results obtained through a novel BES model with those obtained by the current state-of-the-art codes. In this paper, validation test cases for both light-weight and heavy-weight building constructions are presented (case 600 and 900), as well as the free floating cases (case 600FF and 900FF).

3.1. Case 600 and Case 600FF

Case 600 is a light-weight mass rectangular thermal zone ($6\text{m} \times 8\text{m} \times 2.7\text{m}$) with 12 m^2 of south-facing windows (Figure 2). Construction material properties, weather data and other details are provided in ASHRAE 140. A heating and cooling system delivers the required thermal energy to the thermal zone in order to maintain a room air temperature in the range $20\text{-}27^\circ\text{C}$.

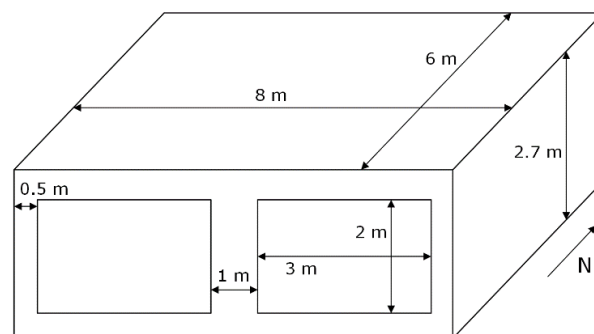

Figure 2: Geometry of the thermal zone.

Table 1 compares annual and peak heating and cooling loads calculated by the Modelica ISO 13790 model with the ones calculated by the other BES tools provided in ASHRAE 140. Results show that the Modelica ISO 13790 model provides values that are comparable with other simulation tools. Annual heating (4.98 MWh) and cooling (6.84 MWh) loads are within the minimum and maximum values

obtained by the other simulation tools. The peak heating (4.03 kW) and cooling (6.01 kW) loads predicted by the Modelica ISO 13790 model are also within the minimum and maximum range. Close agreement was also found regarding the date and hour of peak heating and cooling loads.

Table 1: Annual and peak heating and cooling loads for Case 600

Tool/Model	Annual heating load [MWh]	Annual cooling load [MWh]	Peak heating load [kW] (date and hour)	Peak cooling load [kW] (date and hour)
ESP	4.296	6.137	3.437 (04-Jan, 5AM)	6.194 17-Oct, 1PM
BLAST	4.773	6.433	3.940 (04-Jan, 5AM)	5.965 (16-Oct, 2PM)
DOE2	5.709	7.079	4.045 (04-Jan, 5AM)	6.656 (16-Oct, 1PM)
SRES-SUN	5.226	7.278	4.258 (04-Jan, 2AM)	6.827 (16-Oct, 2PM)
S3PAS	4.882	6.492	4.037 (04-Jan, 2AM)	6.286 (25-Nov, 2PM)
TRNSYS	4.872	6.492	3.931 (04-Jan, 6AM)	6.486 (16-Oct, 2PM)
TASE	5.362	6.778	4.354 (04-Jan, 2AM)	6.812 (17-Oct, 2PM)
ISO 13790	4.982	6.840	4.027 (04-Jan, 4AM)	6.007 (17-Oct, 2PM)

Figure 3a shows the hourly load profiles on the 4th of January, which is the day when the peak heating load occurs. In the figure, heating and cooling loads are represented with positive and negative values respectively. The Modelica ISO 13790 model predicts a cooling load from about 11 AM to 5 PM and a heating load for the rest of the day. This profile is similar to the profiles calculated by other simulation tools. However, the Modelica ISO 13790 model predicts lower cooling loads during daytime.

Case 600FF is based on Case 600 except that there is no heating or cooling system. Therefore, the room air temperature is floating with the weather conditions and the internal gains. The Modelica ISO 13790 model computed an annual average room air temperature of 25.46°C, which is aligned with the ones calculated by the other simulation tools. Figure 3b illustrates the room air temperature profiles on the 4th of January. Generally, the Modelica ISO 13790 models predicts lower room air temperatures during daytime. This is consistent with the results illustrated in Figure 3a in relation to cooling loads.

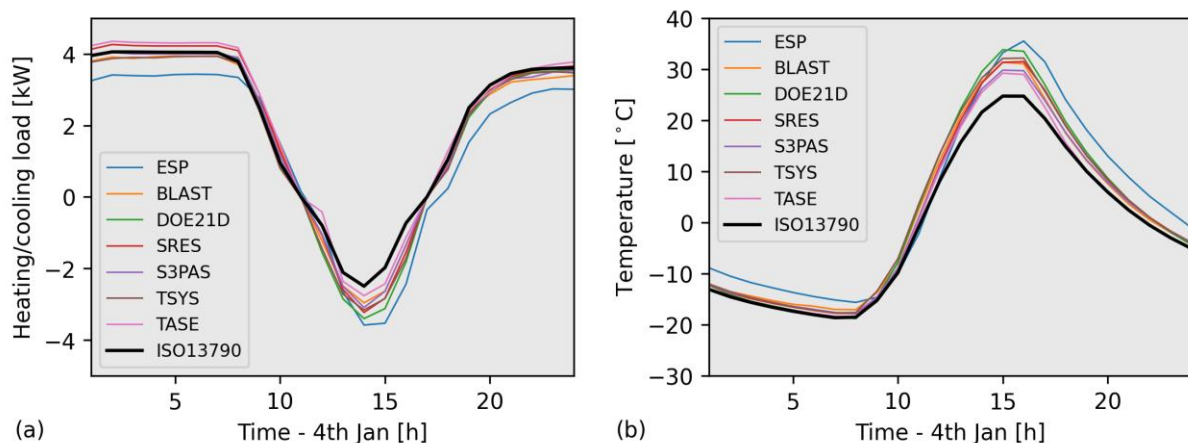

Figure 3: Heating and cooling load profiles for Case 600 on the 4th of January (a). Room air temperature profiles for Case 600FF on the 4th of January (b).

3.2. Case 900 and Case 900FF

Case 900 is a heavy-weight building which uses the same zone model as was used for Case 600 except that the building constructions were changed to use heavier materials. A heavier structure is used to test the ability of a simulation model to treat thermal inertia. Table 2 shows that the Modelica ISO 13790 model provided values that are within the specified range for the annual heating (1.91 MWh) and cooling

(2.97 MWh) loads. The model also predicted peak heating load (3.65 kW) and peak cooling load (3.19 kW) in close agreement with the other simulation tools. The difference observed in the date of the peak cooling load can be caused by different modeling assumptions in the simulation tools. In any case, the peak cooling load on October 17th is 3.03 kW, which is inside the range as well.

Table 2: Annual and peak heating and cooling loads for Case 900

Tool/Model	Annual heating load [MWh]	Annual cooling load [MWh]	Peak heating load [kW] (date and hour)	Peak cooling load [kW] (date and hour)
ESP	1.170	2.132	2.850 (04-Jan, 7AM)	2.888 (17-Oct, 2PM)
BLAST	1.610	2.600	3.453 (04-Jan, 7AM)	3.155 (06-Oct, 3PM)
DOE2	1.872	2.455	3.557 (04-Jan, 7AM)	3.458 (17-Oct, 2PM)
SRES-SUN	1.897	3.165	3.760 (04-Jan, 7AM)	3.871 (17-Oct, 2PM)
S3PAS	1.730	2.572	3.608 (04-Jan, 8AM)	3.334 (17-Oct, 3PM)
TRNSYS	1.655	2.485	3.517 (04-Jan, 7AM)	3.567 (17-Oct, 3PM)
TASE	2.041	2.599	3.797 (04-Jan, 7AM)	3.457 (17-Oct, 3PM)
ISO 13790	1.905	2.965	3.646 (04-Jan, 7AM)	3.191 (02-Sep, 3PM)

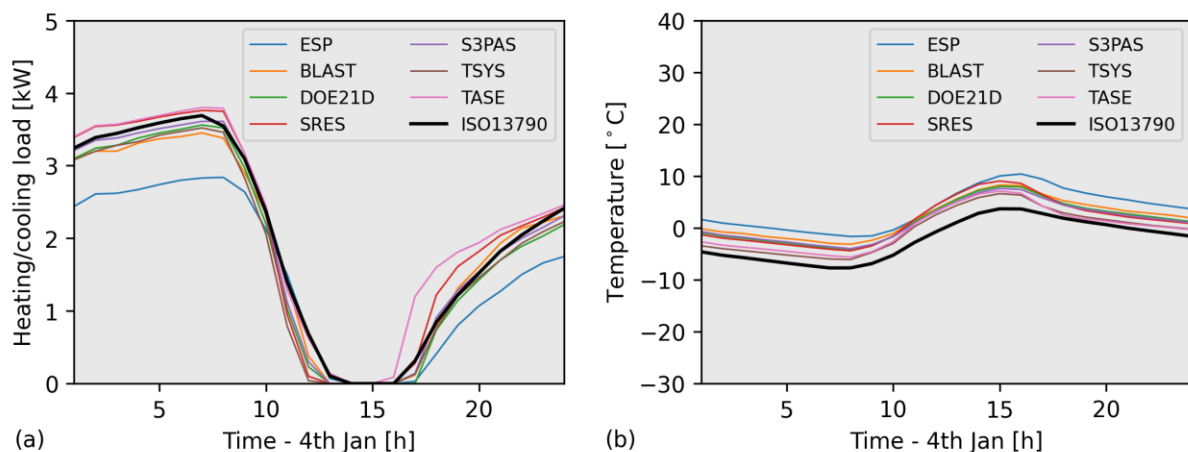

Figure 4: Heating and cooling load profiles for Case 900 on the 4th of January (a). Room air temperature profiles for Case 900FF on the 4th of January (b).

Figure 4a shows the hourly load profiles on the day when the peak heating load occurs (4th of January). The Modelica ISO 13790 model predicted a profile similar to the ones calculated by other simulation tools. Note that in this case, there is no cooling load.

Case 900FF is based on Case 900 except that the room air temperature is floating with the weather conditions and the internal gains. The Modelica ISO 13790 model predicted an annual average room air temperature of 25.51°C, which is in good agreement with the one calculated by the other simulation tools. Figure 4b shows the room air temperature profiles on the 4th of January. Similarly to Case 600FF, the Modelica ISO 13790 model predicts lower room air temperatures than the other tools.

4. Conclusions

This paper presented the development and validation of a simplified building model for urban energy simulations. The model was developed using the Modelica modeling language. It was based on a low-order approach following the ISO 13790 Standard. The validation results showed that the Modelica ISO 13790 model generates similar results in terms of annual and peak heating and cooling loads compared to other simulation tools. However, differences can be seen when evaluating the results at

hourly scale. The simplification on building thermal mass produces low temperatures in free-floating scenarios, even though the final trend is still satisfactory. In addition, mismatches were found regarding the date when the peak cooling loads occur. Such behavior indicates that the model should be used carefully when considering results at hourly scale. In conclusion, the model can be used by scientists and engineers to predict heating and cooling demand of large urban areas with few input parameters and low computational effort. Also, the use of Modelica enables the coupling of building models with district network models into a single comprehensive energy model.

Acknowledgments

This work was financially supported by the Danish Energy Agency, under the Energy Technology Development and Demonstration Programme (EUDP).

This work emerged from the IBPSA Project 1, an international project conducted under the umbrella of the International Building Performance Simulation Association (IBPSA). Project 1 will develop and demonstrate a BIM/GIS and Modelica Framework for building and community energy system design and operation.

References

- [1] United Nations 2018 *The World's Cities in 2018* (New York: UN)
- [2] Remmen P, Lauster M, Mans M, Fuchs M, Osterhage T and Müller D 2018 TEASER: an open tool for urban energy modelling of building stock *J. Build. Perform. Simul.* **11** 84-98
- [3] Mastrucci A, Baume O, Stazi F, Salvucci S and Leopold U 2014 A GIS-based approach to estimate energy savings and indoor thermal comfort for urban housing stock retrofitting *Proc. 5th IBPSA German and Austrian Conf.* Aachen, Germany, Sep 22-24
- [4] Palme M and Salvati 2018 A UWG -TRNSYS Simulation Coupling for Urban Building Energy Modelling *Proc. 4th IBPSA England Conf.* Cambridge, United Kingdom, Sep 11-12
- [5] Vivian J, Zarrella A, Emmi G and De Carli Michele 2017 An evaluation of the suitability of lumped-capacitance models in calculating energy needs and thermal behaviour of buildings *Energy Build.* **150** 447-465
- [6] International Organization for Standardization 2008 *ISO 13790:2008 Energy Performance of Buildings - Calculation of energy use for space heating and cooling*
- [7] Wetter M, van Treeck C, Helsen L, Maccarini A, Saelens D, Robinson D and Schweiger G 2019 IBPSA Project 1: BIM/GIS and Modelica framework for building and community energy system design and operation – ongoing developments, lessons learned and challenges *Proc. IOP Conf. Series: Earth and Environmental Science*, Graz, Austria, Sep 11-14
- [8] The American Society of Heating, Refrigeration and Air-Conditioning Engineers 2007 *ANSI/ASHRAE Standard 140-2007 Method of Test for the Evaluation of Building Energy Analysis Computer Programs* Atlanta: American Society of Heating, Refrigerating and Air-Conditioning Engineers