

Proc. NIPR Symp. Antarct. Meteorites, 3, 270-281, 1990

OBSERVATION OF ALLENDE AND ANTARCTIC
METEORITES BY MONOCHROMATIC X-RAY
CT BASED ON SYNCHROTRON
RADIATION

Tatsumi HIRANO¹, Minoru FUNAKI², Takeshi NAGATA²,
Isamu TAGUCHI³, Hiroki HAMADA⁴,
Katsuhisa USAMI¹ and Kazunobu HAYAKAWA⁵

¹Hitachi Research Laboratory, Hitachi, Ltd., 4026, Kuji-cho, Hitachi 319-12

²National Institute of Polar Research, 9-10, Kaga 1-chome, Itabashi-ku,
Tokyo 173

³National Museum of Japanese History, 117, Jonai-cho, Sakura 285

⁴R & D Laboratory, Analysis Research Laboratory, Nippon Steel
Corporation, Kawasaki 211

⁵Catalysis Research Center, Hokkaido University, Kita-11,
Nishi-10, Kita-ku, Sapporo 060

Abstract: Three-dimensional CT images of the Allende meteorite with a high resolution of 10 μm have been obtained nondestructively by a monochromatic X-ray computed tomography (CT) based on synchrotron radiation (SR). The metallic minerals, matrix and chondrules can be clearly observed in the CT images. The CT values, which express the image intensity, allow a quantitative elemental analysis including such as difference in the metallic minerals, *i.e.*, pentlandite and troilite, using the comparison of CT images and elemental images measured by a computer-aided microanalyzer (CMA). The three-dimensional CT images indicate that the metallic minerals surround some chondrules, and the largest chondrule has two humps and well crystallized olivine in its center. These observations suggest that the three-dimensional SR-CT system is a useful method for identification of internal structures of stony meteorites. Additionally, information obtained from the CT images of Antarctic meteorites confirms that the SR-CT system can be applied to classification of stony chondrites.

1. Introduction

Fine structures and chemical compositions of meteorites are ordinarily examined by optical microscopy, SEM and EPMA after cutting them out or polishing them. However, contamination or defects occasionally affect the meteorites' surface, during the preparation process. Then, it is difficult to observe spatial structures, if these methods are used. Further, destructive inspection methods cannot be applied to a small amount of the meteorites. A non-destructive method is necessary for examination of the spatial fine structures. The X-ray computed tomography (CT) is a non-destructive method for obtaining cross sectional images of objects as X-ray linear attenuation coefficients. This technique has been available not only for a medical diagnosis, but also for evaluation of materials. MASUDA *et al.* (1986) reported the CT

images of Antarctic meteorites (H and L chondrites) taken by a X-ray CT scanner for non-medical use. To apply X-ray CT to observation of internal structures of meteorites, the following points are important: 1) improvement of the spatial resolution of X-ray CT images; 2) quantitative measurements of the amount of metallic components in meteorites; and 3) three-dimensional observation of meteorites. Commercial X-ray CT systems, however, have a low spatial resolution of about 0.1 mm and a low accuracy in measuring coefficients of X-ray absorption because they use a continuous X-ray spectrum from high-voltage X-ray tubes.

Since a synchrotron radiation (SR) source produces a tunable, monochromatic, and naturally collimated beam it is a suitable X-ray source for taking CT images of high quality. The SR source produces the following advantages: 1) high spatial resolutions as a result of beam collimation; 2) spatial distributions of a specific element*; and 3) quantitative measurements of CT images since there are no hardening effects** by using monochromatic X-rays. THOMPSON *et al.* (1984) first reported iodine CT images of a pig heart filled with an iodinated medium by an X-ray CT scanner using SR. Several groups (BORODIN *et al.*, 1986; FLANNERY *et al.*, 1987; KINNEY *et al.*, 1988) have developed SR-CT scanners which were applied not only to medical use but also to nondestructive inspection of industrial materials. We have also developed a high resolution SR-CT and obtained CT images of several industrial materials with the resolution of 10 μm using a high resolution X-ray sensing pickup tube (HIRANO and USAMI, 1989) and have done some quantitative elemental analysis (HIRANO *et al.*, 1989).

In this study, three-dimensional CT measurement is developed and applied to observation of spatial structures in the Allende meteorite and Antarctic meteorites. The Allende meteorite is very interesting because the chondrules it included may be early condensate from the solar nebula (SIMON and HAGGERTY, 1979). The spatial structures and configurations of substances in the Allende meteorite have not yet been observed using a nondestructive method. In this paper, the three-dimensional distribution of the chondrules is described and the distribution of metallic components is compared with the results from EPMA. The CT images of Antarctic meteorites are also presented herein.

2. Instrumentation and Experimental

2.1. SR-CT system

The SR-CT imaging system was installed at the experimental station BL-8C connected to the KEK Photon Factory 2.5 GeV electron storage ring. Details of the constructed CT scanner have been presented elsewhere (SUZUKI *et al.*, 1988a; SAKAMOTO *et al.*, 1988). Figure 1 shows a schematic diagram of the developed CT scanner. SR, having a white spectrum, was monochromatized through a crystal monochromator

* The difference between two CT images taken above and below the absorption edge energy of a specific element can produce spatial distributions of the element.

** Using a continuous X-ray beam produced by an X-ray tube, a specimen changes the transmitted X-ray into a harder spectrum than the incident X-ray spectrum because the low energy X-rays are attenuated more than the high energy X-rays.

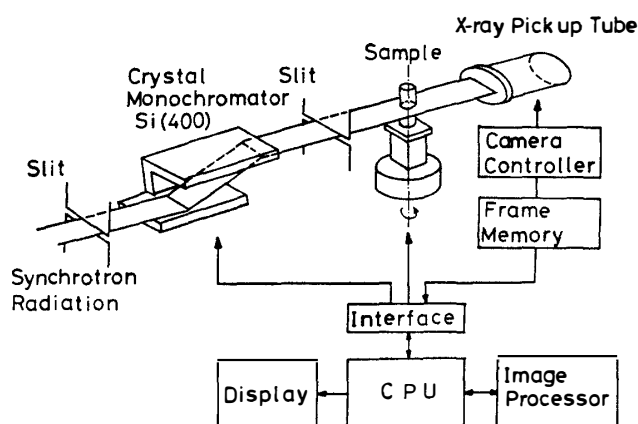

Fig. 1. Schematic diagram of the SR-CT.

and was applied to a specimen. The size of the specimen to which the SR-CT system could be applied was about $5\text{ mm}\phi \cdot 20\text{ mm}$. The projection image transmitted through the specimen was detected by an X-ray sensing pickup tube (HS501X, Hitachi Denshi Ltd.). The energy range of the X-ray beam monochromatized by a Si(400) channel cut crystal was from 20 to 40 keV. The output intensity from the Si(400) monochromator measured with a ionization chamber was $6 \cdot 10^3$ photons/(s \cdot mA \cdot mm²) at 30 keV photon energy. A typical current of about 250 mA was stored in the experimental mode. The X-ray pickup tube, with a limiting resolution of about $8\ \mu\text{m}$ (SUZUKI *et al.*, 1988b), had a maximum spectral sensitivity of $2 \cdot 10^{-17}$ coulomb/photon at 30 keV. The output signal from the pickup tube, which detected a two-dimensional projection image, was stored in a 2-Mbyte frame memory after being amplified and digitalized. The electron beam scan in the pickup tube, controlled by the TV camera, was characterized by 960 effective scanning lines, non-interlace and 7.5 frame/s scanning. The scanning area ($12.7 \cdot 9.5\text{ mm}^2$; standard) was variable of factor two. The projection image consisted of 1024×960 elements whose size was determined by the analog/digital converter (ADC) sampling pitch and scanning line width. In this experiment, ADC sampling pitch and line width were $6.5\ \mu\text{m}$ and $12.2\ \mu\text{m}$, respectively.

2.2. Measuring system for three-dimensional CT image

A two-dimensional CT image of a specimen is reconstructed from a large number of one-dimensional projection images irradiated at different angles. A large number of two-dimensional projection images produces a three-dimensional CT image. A block diagram for measuring the three-dimensional CT image is shown in Fig. 2. CT images are fundamentally reconstructed from every scanning line. However, an enormous amount of memory capacity and calculation time are necessary. We improved the measurement software system, which condenses the two-dimensional projection image of 960 scanning lines to a maximum of 40 slice planes by accumulating several scanning lines. Slice position, slice width and slice interval between the slice planes can be arbitrarily selected in the accumulating process of scanning lines, *e.g.* minimum slice width of one scanning line and minimum slice interval of zero scanning line. The projection image, consisting of selected slice planes, was stored in a memory region of the image processing computer. Then 180 projections of a specimen, at 1

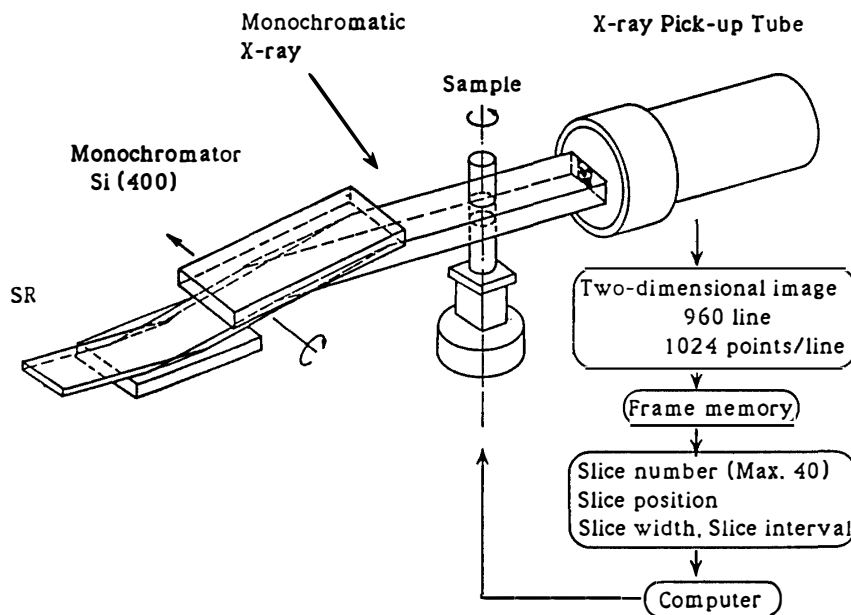

Fig. 2. Block diagram for measuring three-dimensional CT images.

degree intervals, were measured by rotating it. The CT image at each slice plane was reconstructed from these projections by a filtered back-projection method using a Shepp-Logan's type convolution filter.

3. Results and Discussion

3.1. Measurement of CT images of the Allende meteorite

The advantage of using monochromatic X-rays is the ability to reconstruct a specific element image based on the difference between two CT images just above and below its absorption edge. However, this subtraction method could not be applied to the Allende meteorite because many of its metallic components strongly attenuated the X-rays at the absorption edge energy (Fe-K, Ni-K). The Allende meteorite was measured at 30 keV energy with twenty slice planes, as shown schematically in Fig. 3. The slice thickness was $37 \mu\text{m}$ and the slice planes were spaced at $110 \mu\text{m}$ intervals. The exposure time per one projection and the total exposure time were 28.1 s and 5120 s, respectively. The absorbed dose was about 10 rad. In this case, the radiation damage of the Allende meteorite was not clear. However, it is thought that inorganic materials are least influenced by the radiation because of the low energy X-rays used. Three CT images of the Allende meteorite, the sixth to eighth slice planes, are also displayed in Fig. 3, where the CT images are represented in color separated into twenty levels from black to red. The red pixel expresses the highest X-ray attenuated region. Heavy elements attenuate the X-ray beam more than light elements. The spherical purple and blue regions are thought to correspond to chondrules and matrix, respectively. The matrix attenuates the X-ray beam more than the chondrules, so that there is much more metal in the former. The red or yellow regions in the boundary between the matrix and the chondrules are many times more opaque than the matrix. These highly attenuated regions are assumed to be rich in iron or nickel, which are known

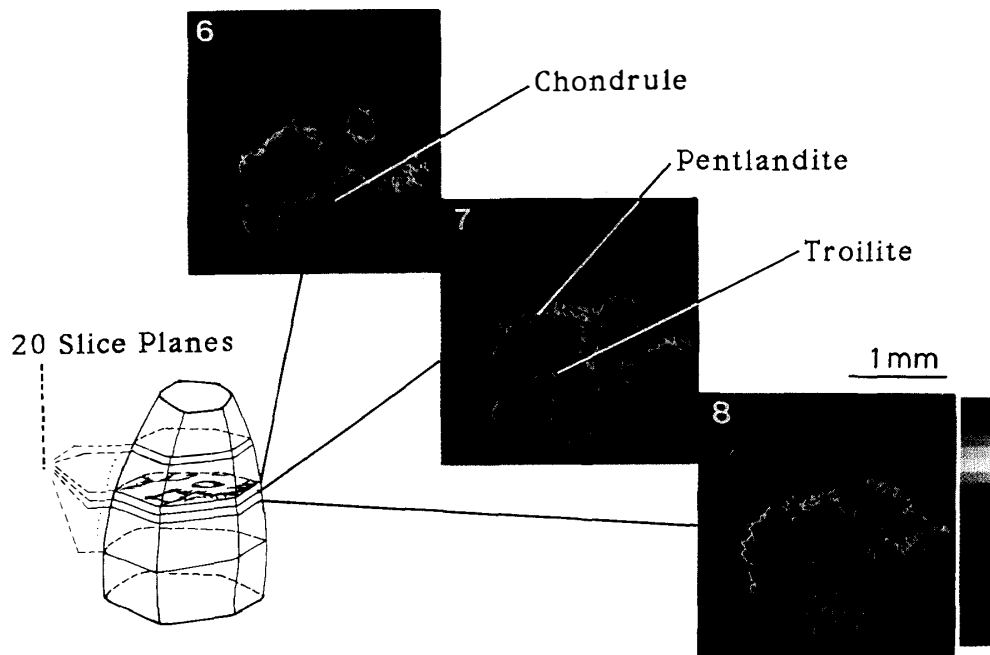

Fig. 3. Illustration of the Allende meteorite and CT images. The Allende meteorite was measured at 30 keV with twenty slice planes. The slice thickness was $37\ \mu\text{m}$ and the slice planes were spaced at $110\ \mu\text{m}$ intervals.

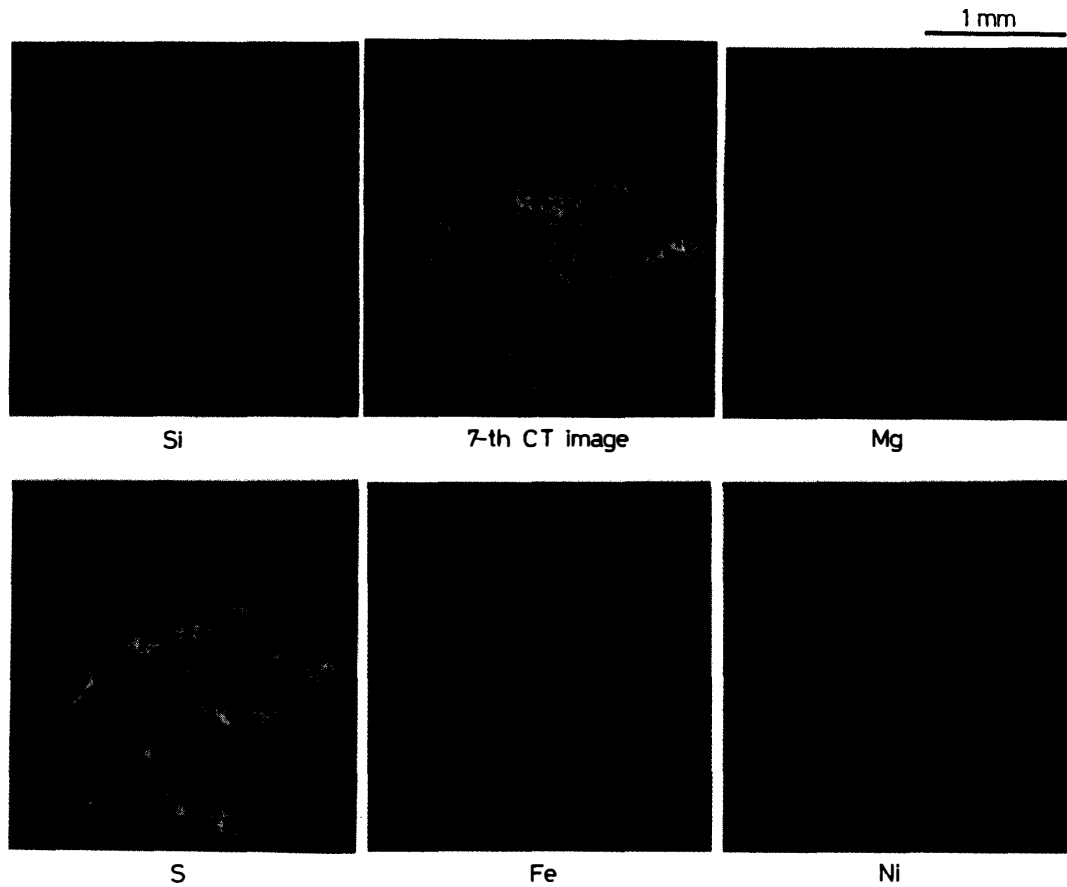

Fig. 4. Seventh CT image of the Allende meteorite compared with the elemental images measured by a computer-aided microanalyzer (CMA), after cutting it out near the seventh slice plane.

to be present in the Allende meteorite.

3.2. Quantitative elemental analysis

In order to identify several elements in the Allende meteorite, it was evaluated by a computer-aided microanalyzer (CMA), after cutting it out near the seventh slice plane. The CMA (TAGUCHI and HAMADA, 1985) produces the elemental images with a coloring technique by scanning the sample based on EPMA method. Figure 4 shows the seventh CT image and five elemental images (Si, Mg, S, Fe, Ni) measured by the CMA. The configurations in the elemental images seem to be in good agreement with those of the CT image. The chondrules consist mainly of Si and Mg. Si and Fe are uniformly distributed in the matrix. Fe compounds in the matrix cause more attenuation of the X-ray beam than in the chondrules. The metallic components are thought to be composed of pentlandite (Fe, Ni, S) and troilite (Fe, S). Since the X-ray attenuation coefficient of pentlandite is higher than that of troilite at 30 keV energy, the red and yellow regions in the CT image are thought to correspond roughly to pentlandite and troilite, respectively.

It is possible to make a quantitative elemental analysis using the EPMA results and CT values, which numerically express the CT image intensity. In the SR-CT system, the reconstructed CT values, which are proportional to X-ray attenuation coefficients, are given in integers so that it is necessary to calibrate the CT values to the attenuation coefficients. The calibration was obtained experimentally by measuring the CT image of pure water and Al and Ni wires at 30 keV energy during the time as the CT images of the Allende meteorite were taken. The average CT values of water, Al and Ni are plotted in Fig. 5 against the X-ray attenuation coefficients μ (cm^{-1}) calculated from photo cross-section tables. These average CT values have a good linear relation to μ , and calibration can be done in the region of μ from 0.20 to 88 cm^{-1} . Figure 6 shows a frequency distribution of the CT value at the seventh slice plane of the Allende meteorite CT image. The table inserted in Fig. 6 lists the chemical compositions of pentlandite, troilite, the matrix and the chondrules, which were measured by EPMA. The CT values of the two minerals, pentlandite and troilite, which were obtained by both μ calculated from their chemical compositions and the relation shown in Fig. 5, are indicated by arrows. The calculated CT values of the matrix and chondrules are similarly shown. Since there are many pixels expressing the matrix region, the frequency distribution corresponding to the matrix forms the peak in Fig. 6. The

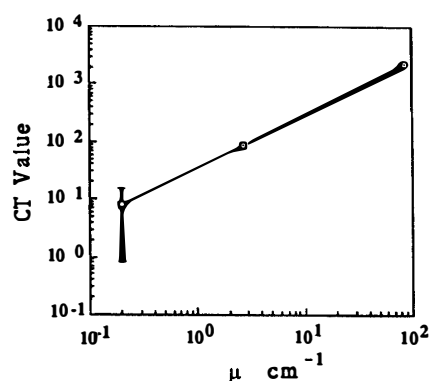

Fig. 5. Calibration curve of CT value to X-ray attenuation coefficient (μ).

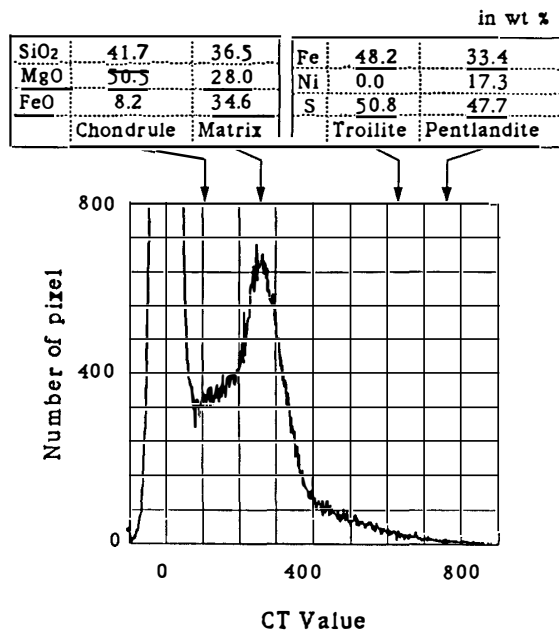

Fig. 6. Frequency distribution of CT value at the seventh CT image of the Allende meteorite. Table shows chemical compositions of constituent elements, measured by EPMA. They are indicated by arrows corresponding to the CT values.

peak position of the matrix is in good agreement with the CT value calculated from its chemical compositions. The CT values, forming the peak (off-scale) around zero, indicate a region of no matter. The region between the two peaks expresses the CT values of the chondrules. The CT values of the minerals, which are larger than those of the matrix, are distributed over a broad region. This indicates that chemical compositions of the minerals vary. From the frequency distribution of every slice plane, the each volume ratio of the chondrules, the matrix or all the minerals of the Allende meteorite can be easily estimated to be 28.5% ($90 \leq \text{CT value} < 200$), 65.4% ($200 \leq \text{CT value} < 500$) and 6.1% ($500 \leq \text{CT value}$), respectively.

3.3. Three-dimensional CT images of the Allende meteorite

Figure 7 displays eight CT images of the Allende meteorite at the second to ninth slice planes. From the second to fourth CT images, nearly spherical chondrules, which are expressed by purple, can be observed and have a typical diameter of 0.1–0.5 mm. Part of a large chondrule, about 2 mm in diameter, is seen in the seventh to ninth CT images. The Allende meteorite is very dense, and has no cracks nor open spaces of more than 10 μm in size. The largest chondrule is surrounded by the minerals, pentlandite and troilite, and a part of them extends into the matrix. The sections, marked by white arrows in the fifth and sixth CT images, gradually grow and form a part of the largest chondrule from the fifth to the eighth CT images. This indicates that the largest chondrule has two humps. From these observations, it is guessed that during the cooling process from a liquid, which is the origin of the chondrules, to the chondrules, they collided with one another and formed the humps of the largest chondrules. Further, olivine and such minerals as pentlandite and troilite, which constitute the matrix, were piled up on a original parent body of the Allende meteorite with the chondrules. It is thought that somewhat denatured action on the parent body formed the metallic minerals surrounding the chondrules.

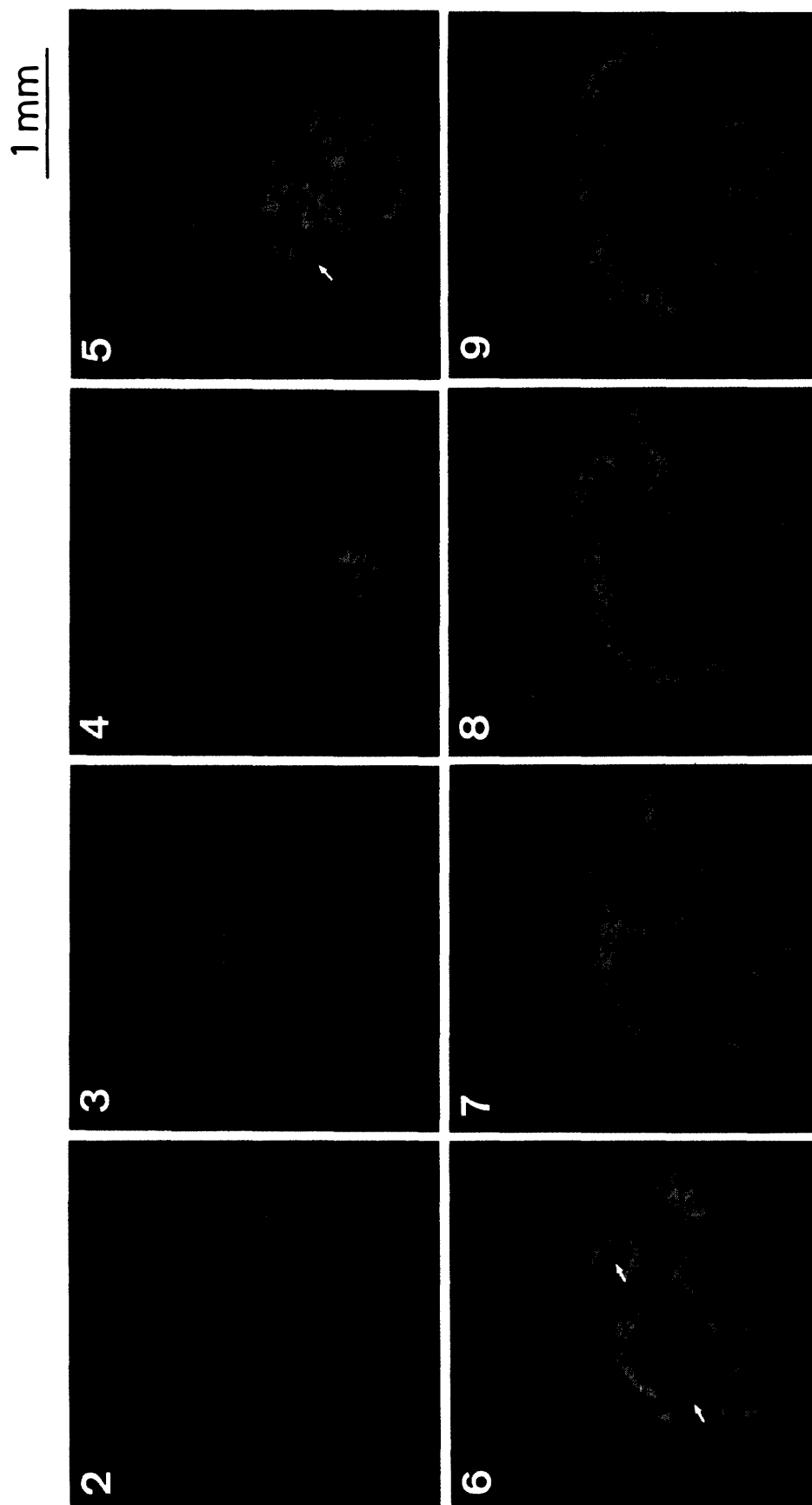

Fig. 7. Consecutive CT images of Allende meteorite (2-9).

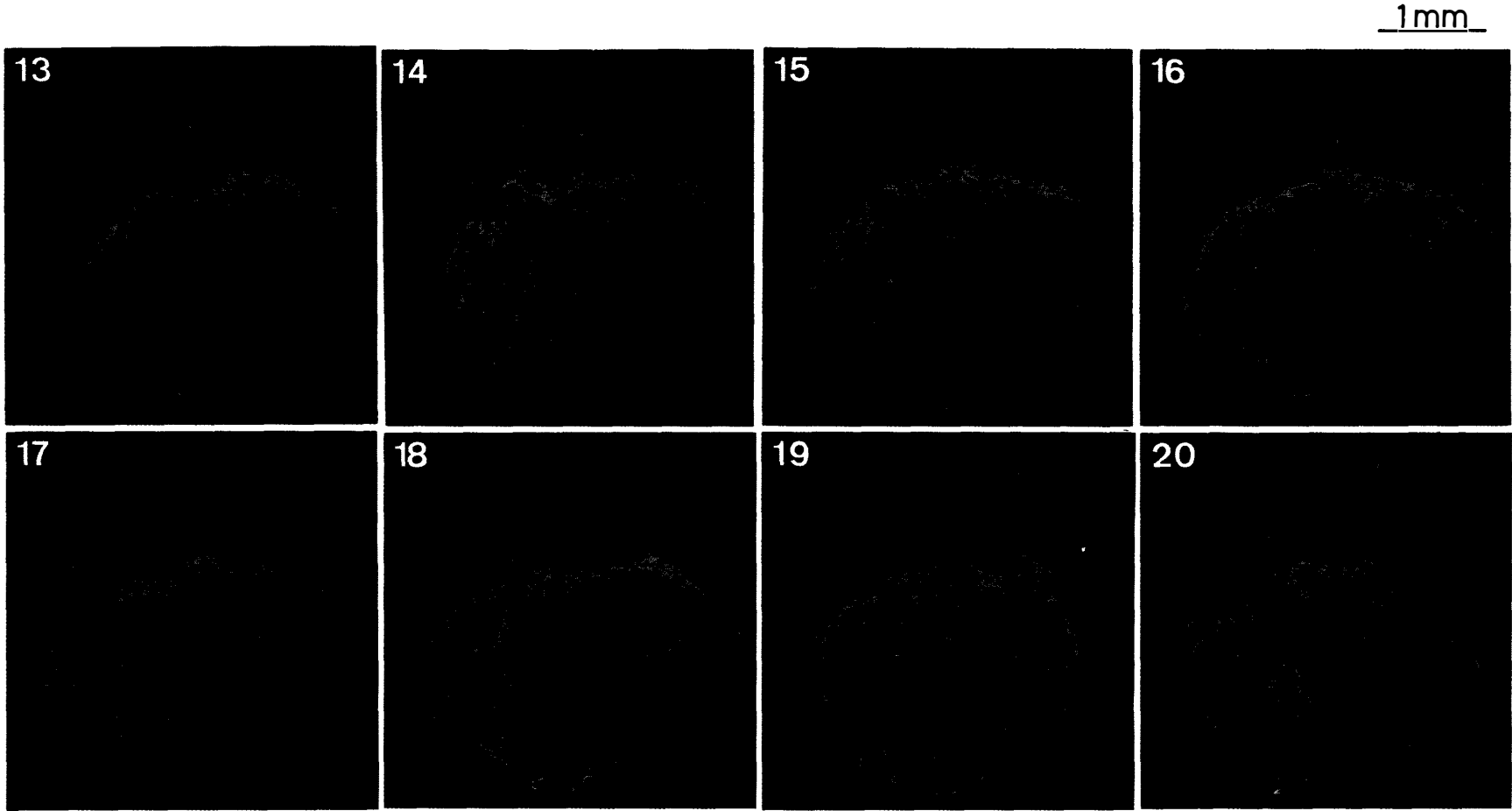

Fig. 8. Consecutive CT images of Allende meteorite (13–20).

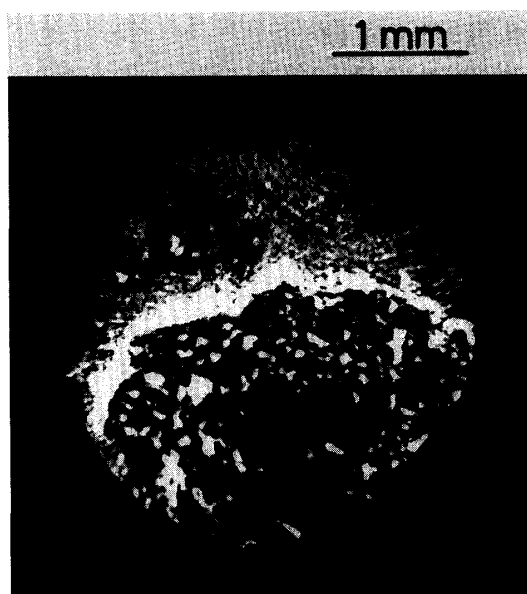
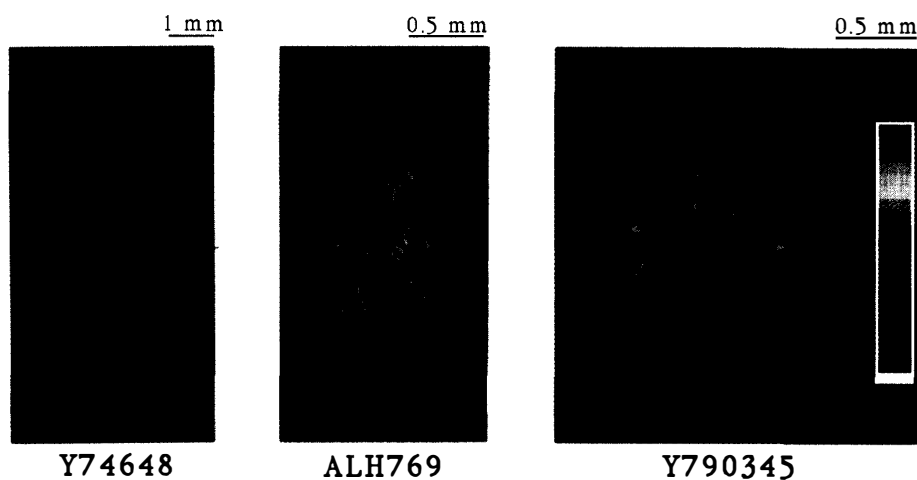

Fig. 9. CT image of the Allende meteorite at the seventeenth slice plane, displayed by a gray minerals with 256 levels.



Slice Thickness, μm	47	117	117
Exp. Time, s	19	28	28
Energy, keV	30	29	29

Fig. 10. CT images of Antarctic meteorites.

The thirteenth to twentieth CT images of the Allende meteorite are shown in Fig. 8. These display serial slice planes of the largest chondrule. The minerals such as pentlandite and troilite exist not only in the boundary between the matrix and the largest chondrule, but also in the chondrule itself. Further, the nearly central region of the largest chondrule has no metallic minerals, represented by purple, in the fifteenth to eighteenth CT images. It is thought to be a well crystallized olivine. Figure 9 shows the seventeenth CT image, which is displayed with gray shading of 256 levels. Details of the olivine can be observed. It has a lamination structure. The planes, including a high density region or metal, seem to be regularly placed. This is thought

to reflect the formation of the largest chondrule, *i.e.* the cooling process.

3.4. CT measurements of Antarctic meteorites

In order to confirm the applicability of the SR-CT system to classification of stony chondrites, some Antarctic meteorites, which differed in the amount of metallic component corresponding to the class, were examined. Three CT images of the Antarctic meteorites, *i.e.*, Y-74648 (diogenite), ALH-769 (L6) and Y-790345 (LL) are shown in Fig. 10. The measurement conditions are summarized in the figure. The metallic amount is smaller in Y-74648 and the metallic grains are small, being 30 μm . The configurations of the two CT images of ALH-769 and Y-790345 are very similar. It is seen that the metallic amount in ALH-769 is larger than that in Y-790345. The amount can be expressed numerically using the CT values and calibration curve. The area ratio and the average X-ray attenuation coefficient of the metallic composition in ALH-769 shown in Fig. 10 are 3.3% and 26.35 cm^{-1} . Similarly, they are 0.7% and 20.7 cm^{-1} in Y-790345. These results imply that ALH-769 includes a larger amount of metal and is higher in metal density than Y-790345, if the metallic components in ALH-769 and Y-790345 are same. This suggests that the SR-CT system is confirmed as applicable to classification of stony chondrites.

4. Conclusion

The three-dimensional CT images of the Allende and Antarctic meteorites were taken by a high resolution, tunably monochromatic X-ray CT based on synchrotron radiation. The SR-CT system measuring three-dimensional CT images has been developed and applied to observe the spatial internal structures of the Allende meteorite. The CT images of the Allende could be used to identify the metallic minerals, matrix and chondrules. Further, the metallic minerals, such as pentlandite and troilite could be distinguished from each other in the CT images, by comparing the CT image and the elemental image measured by computer-aided microanalyzer (CMA, a kind of scanning EPMA), after cutting out the Allende at a CT slice plane. The volume ratio of the chondrules and the metallic minerals for all of the Allende meteorite could be easily estimated from the CT values which corresponded to them. Three-dimensional CT images, which consisted of twenty slice planes of the Allende meteorite, indicated the following points.

- 1) The chondrules were typically 0.1–2 mm in diameter.
- 2) The metallic minerals, *i.e.*, pentlandite and troilite were formed surrounding some of the chondrules.
- 3) The largest chondrule had two humps on its surface and well crystallized olivine in its center.

These results suggested that the three-dimensional SR-CT system was a useful method for identification of internal structures and configurations for substances of stony meteorites. The Antarctic meteorites, *e.g.*, Y-74648 (diogenite), ALH-769 (L6) and Y-790345 (LL), which belong to different classes, were measured by the SR-CT system. Since each CT value, corresponding to the metallic minerals in the CT images, reflected the amount of a metallic compositions, the SR-CT system can be applied to

classification of stony chondrites.

Acknowledgments

We would like to thank the staff of KEK Photon Factory for their helpful advice on the use of synchrotron radiation. We also appreciate the useful advice of Y. HIRAI.

This work has been performed under the approval of the National Laboratory for High Energy Physics (Accepted No. 88-U003).

References

- BORODIN, Yu. I., DEMENTYEV, E. N., DRAGUN, G. N., KULIPANOV, G. N., MEZENTSEV, N. A., PINDYURIN, V. F. *et al.* (1986): Scanning X-ray difference microscopy and microtomography using synchrotron radiation of the storage ring VEPP-4. *Nucl. Instrum. Methods Phys. Res.*, **A246**, 649–654.
- FLANNERY, B. P., DECKMAN, H. W., ROBERGE, W. G. and D'AMICO, K. (1987): Three-dimensional X-ray microtomography. *Science*, **237**, 1439–1444.
- HIRANO, T. and USAMI, K. (1989): High resolution monochromatic X-ray tomography using synchrotron radiation. *Jpn. J. Appl. Phys.*, **28**, 263–266.
- HIRANO, T., EGUCHI, S. and USAMI, K. (1989): Study of quantitative elemental analysis of monochromatic X-ray CT using synchrotron radiation. *Jpn. J. Appl. Phys.*, **28**, 135–139.
- KINNEY, J. H., JOHNSON, Q. C., BONSE, U., NICHOLS, M. C., SAROYAN, R. A., NUSSHARDT, R., PAHL, R. and BRASE, J. M. (1988): Three-dimensional X-ray computed tomography in materials science. *MRS. Bull.*, **13**, 13–17.
- MASUDA, A., TAGUCHI, I. and TANAKA, K. (1986): Non-destructive analysis of meteorites by using a high-energy X-ray CT scanner. Papers Presented to the Eleventh Symposium on Antarctic Meteorites, 25–27 March 1986 Tokyo, Natl Inst. Polar Res., 148–149.
- SAKAMOTO, K., SUZUKI, Y., HIRANO, T. and USAMI, K. (1988): Improvement of spatial resolution of monochromatic X-ray CT using synchrotron radiation. *Jpn. J. Appl. Phys.*, **27**, 127–132.
- SIMON, S. B. and HAGGERTY, S. E. (1979): Petrography and olivine mineral chemistry of chondrules and inclusions in the Allende meteorite. *Proc. Lunar Planet. Sci. Conf.*, 10th, 871–883.
- SUZUKI, Y., USAMI, K., SAKAMOTO, K., KOZAKA, H., HIRANO, T., SHIONO, H. and KOHNO, H. (1988a): X-ray computed tomography using monochromated synchrotron radiation. *Jpn. J. Appl. Phys.*, **27**, L461–464.
- SUZUKI, Y., HAYAKAWA, K., USAMI, K., HIRANO, T., ENDOO, T. and OKAMURA, Y. (1988b): X-ray sensing pickup tube. *Jpn. J. Appl. Phys.*, **27**, 420–423.
- TAGUCHI, I. and HAMADA, H. (1985): Development of new computer-aided microanalyzer and its application to iron steel analysis. *Anal. Sci.*, **1**, 119–124.
- THOMPSON, A. C., LLACER, J., FINMAN, L. C., HUGHES, E. B., OTIS, J. N., WILSON, S. and ZEMAN, H. D. (1984): Computed tomography using synchrotron radiation. *Nucl. Instrum. Methods Phys. Res.*, **222**, 319–323.

(Received September 18, 1989; Revised manuscript received January 22, 1990)