

UPPER ATMOSPHERE PHYSICS DATA OBTAINED AT SYOWA STATION IN 1995

Toyoshi ARISAWA¹, Yasuo KATO², Kazuhiro OTAKA³, Yasuharu INAMORI³,
Masayuki KANEKO⁴ and Makoto TAGUCHI⁵

¹ *University of Electro-Communications, Chofu-shi, Tokyo 182*

² *Solar-Terrestrial Environment Laboratory, Nagoya University, Honohara, Toyokawa 442*

³ *Communications Research Laboratory, Koganei-shi, Tokyo 184*

⁴ *Nippon Electric Company, Midori-ku, Yokohama 226*

⁵ *National Institute of Polar Research, Itabashi-ku, Tokyo 173*

1. Introduction

This data book summarizes upper atmosphere physics data acquired by the 36th Japanese Antarctic Research Expedition (JARE-36) with the "Upper Atmosphere Physics Monitoring (UAPM) System" at Syowa Station in 1995. Observation items are as follows:

- 1) Geomagnetism :
 - H-, D- and Z-components of magnetic variations
 - Total force of the geomagnetic field
 - H-, D- and Z-components of magnetic pulsations
- 2) ELF-VLF wave :
 - Intensities at 0.35, 0.75, 1.2, 2, 4, 8, 30, 60 and 95 kHz
 - Wide-band (0-10 kHz) signal of ELF-VLF emissions
- 3) Ionosphere :
 - Cosmic noise absorption at 30 MHz observed with a broad-beam riometer
- 4) Aurora :
 - All-sky cameras :
 - Film type : Panchromatic images recorded on color films
 - CCD digital type : Panchromatic digital images and intensity-time profiles along magnetic meridian
 - Scanning photometers :
 - Meridian-scanning record at the following three wavelengths
557.7 nm (OI), 630.0 nm (OI) and 486.1 nm (H β)

An outline of the observation system is given in Section 2. Section 3 describes specifications of the observation instruments and the data acquisition systems. Observation periods are also listed in Section 3. Format of the compiled digital data is shown in Section 4. Summary plots in the period of January 1-December 31, 1995 are given in Appendix.

All-sky camera observation data, magnetograms and summary plots of the monitoring data are available to users on request. The request should be addressed to:

World Data Center C2 for Aurora
National Institute of Polar Research
9-10, Kaga 1-chome, Itabashi-ku,
Tokyo 173, Japan.

Digital and analog data described here are available to researchers who will do collaborative studies with the upper atmosphere physics group of NIPR. The request should be addressed to:

Upper Atmosphere Physics Research Division
National Institute of Polar Research
9-10, Kaga 1-chome, Itabashi-ku,
Tokyo 173, Japan.

2. Upper Atmosphere Physics Monitoring (UAPM) System

A real-time digital data acquisition system for upper atmosphere physics observation was constructed at Syowa Station in January 1981 (Sato *et al.*, 1984). Data obtained from the system have been collected and published annually in the JARE Data Reports (Upper Atmosphere Physics) (Sato *et al.*, 1984, 1991 ; Fujii *et al.*, 1985, 1994; Sakurai *et al.*, 1985; Ono *et al.*, 1986, 1993; Yamagishi *et al.*, 1987; Kikuchi *et al.*, 1988; Miyaoka *et al.*, 1990; Kadokura *et al.*, 1992; Yamazaki *et al.*, 1995; Tonegawa *et al.*, 1996; Obara *et al.*, 1996). This report is the 15th of this series.

A block diagram of the system, including other ground observations, is shown in Fig. 1. The sensors for measuring weak natural electromagnetic waves such as ELF-VLF emissions, the three components of ULF magnetic pulsations and cosmic radio noise absorption (CNA) have been placed at a remote station on West Ongul Island, located about 5 km from Syowa Station in order to avoid man-made electromagnetic interference. Data of the magnetic pulsations and CNA are transmitted continuously to Syowa Station by a PCM telemeter in VHF band. Wide-band signals of ELF-VLF emissions are transmitted to Syowa Station through an FM telemeter in UHF band.

At the remote station, the electric power which drives all the instruments has been supplied by a solar battery system with maximum output power of 530 W since February 1985. An additional solar battery system with maximum power of 365 W was installed in January 1987 to reinforce the original battery system. The solar battery system consists of eighteen rechargeable car batteries (200 Ah each), five solar panels and three controllers in total. During winter when no sunlight is available, these batteries are charged manually about once a month by using a 10 kVA diesel-engine dynamo, which was installed in 1992 instead of the previous 16 kVA one.

The fluxgate and proton magnetometer sensors are placed at Syowa Station on East Ongul

Island, about 150 m apart from the Data Processing Building. All the auroral photometric instruments are placed on the roof of the building, and the data acquisition facilities are installed inside the building. All the outputs obtained from the observation instruments except the auroral photometric ones are transferred to the matrix terminal board and then recorded with pen recorders, analog data recorders and a computer system. These data have been recorded simultaneously with two sets of the TEAC DR-200 digital data logger systems since January 1987. An 8 mm video tape recorder is used to record wide-band VLF emissions, and 24-hour data can be stored on one volume of 8 mm video tape.

Universal time (UT) is supplied from a precise time-keeping system. This system consists of an NNSS satellite timing receiver, a quartz frequency standard with a stability of 2×10^{-11} /day, and time code generators. The time code generators supply the IRIG-A, -B and slow codes for analog data recorders and the 36-bit BCD code for the digital recording systems, respectively. The absolute accuracy of this system is estimated to be about 1 ms.

3. Specifications of Instruments

3.1. Geomagnetism

(1) *Magnetogram*

Magnetic variations were measured by a three-axis fluxgate magnetometer. Full scale ranges were +1250 to -3750 nT for H-component and ± 2500 nT for D- and Z- components, respectively, with the frequency response of DC-2 Hz and noise levels less than 0.5 nT. The magnetometer data were recorded in digital form at the sampling rate of 1 Hz. The H-component data were also recorded on a chart recorder and an R-950L long-term analog data recorder.

(2) *Total force of the geomagnetic field*

Due to the prolonged trouble with the proton magnetometer since January 1991, the total force observations were made only about once per month in 1995, using the other portable proton magnetometer, which was unable to be linked with the UAPM system. The results are listed in Table 1.

(3) *ULF magnetic pulsations*

The H-, D-, and Z-components of ULF magnetic pulsations are detected by three sets of search coil magnetometers. The search coil sensors have copper wires (0.4 mm ϕ , 40000 turns each) wound around permalloy cores (1 cm in diameter \times 100 cm in length). Measurable intensity range of the magnetometer is 0.001-5 nT/s and the frequency response is 0.001-3 Hz. The search coil magnetometers are installed at the remote station on West Ongul Island. The output signals transmitted by the PCM telemeter are recorded on an R-950L long-term analog data recorder, a chart recorder and a digital data recorder. The sampling frequency of the digital data is 1 Hz for each component.

(4) *Base line of the magnetic field and K-index*

Base line values of the magnetic field were observed about once per month during a magnetically quiet day. K-indices are calculated for every 3-hour interval measuring the maximum deviations of the H- and D-component magnetic fields from the quiet-day baselines. The definition of the K-indices at Syowa Station is as follows:

<u>K-index</u>	<u>Deviation</u>	<u>K-index</u>	<u>Deviation</u>
0	: 0 - 25 nT	5	: 350 - 600 nT
1	: 25 - 50	6	: 600 - 1000
2	: 50 - 100	7	: 1000 - 1660
3	: 100 - 200	8	: 1660 - 2500
4	: 200 - 350	9	: 2500 and more

The ordinary magnetogram is also available on chart papers with a recording speed of 5 cm/hr. The sensitivity of each component on the chart papers is about 100 nT/cm. Table 1 and 2 give the baseline values and K-indices at Syowa Station in February 1995 - January 1996. Inquiries or requests for the data copies of the magnetic field measurements should be addressed to World Data Center C2 for Aurora in NIPR.

3.2. ELF-VLF waves

The natural ELF-VLF wave receiving system at the remote station has consisted of a triangle-shaped three turn loop antenna (10 m in height, 20 m in the bottom side), a pre-amplifier and a main amplifier with gains of 60 and 40 dB, respectively. The ELF-VLF wave intensities at the frequency bands of 0.35, 0.75, 1.2, 2, 4, 8, 30, 60, 95 kHz were obtained from wide band waveforms using a 9-channel filter bank and detectors. The ELF-VLF emissions within the intensity range of 10^{-17} to 10^{-13} W/m² Hz were detectable with this system. These data were recorded continuously in digital form at the sampling rate of 1 Hz. Some of the wide-band ELF-VLF signals up to 10 kHz were recorded on 8 mm video tape recorders. The wide-band recording was executed during 0900-1300 UT on Sunday - Friday.

3.3. Ionosphere

Cosmic noise absorption at 30 MHz was observed with a broad-beam riometer, which has been installed at the remote station on West Ongul Island since 1981. Its beam half-width is 60°. Used receiver is made by La Jolla Science, and bandwidth and time constant are 150 kHz and 0.25 s, respectively. The riometer data were recorded in digital form at the sampling rate of 1 Hz in the UAPM system.

Data of ionospheric vertical sounders, broad-beam riometers (20 and 30 MHz), HF field strength receivers (8 and 10 MHz) and the VHF auroral radar (50 and 112 MHz) were recorded with other observation systems at Syowa Station, and the observational results have been published in another JARE Data Reports(Ionosphere). Inquiries and requests for the data copies are to be

addressed to:

World Data Center C2 for Ionosphere
Communications Research Laboratory
Ministry of Posts and Telecommunications
2-1, Nukui-Kitamachi 4-chome, Koganei-shi,
Tokyo 184, Japan.

3.4. Aurora

(1) *All-sky camera*

CCD digital type and film-type all-sky cameras were used for all-sky observations of aurora in 1995. The CCD type camera installed in 1994 (Obara *et al.*, 1996) was not operated from March 5 through early July due to failure in the work station for control of the CCD camera. During that period all-sky observation was made by the traditional film-type camera which uses KODAK-EASTMAN 5226, ISO-500, 400 ft, 35 mm color films. The observation was switched to the CCD type camera after repair of its failure, continuing to October 6. A digital image obtained by the CCD type camera has 1000(H) × 1018(V) pixels with 12 bit resolution. Exposure time was variable from 1 to 53 s for the CCD type camera but fixed to 6 s for the film-type camera, while observation interval was 10 or 30 s for both the cameras. A fish-eye lens of F/1.4 is used in the film-type observation. Observation lists for the CCD-type and the film-type are given in Table 3(a) and 3(b), respectively. Inquiries or requests for the all-sky data should be addressed to World Data Center C2 for Aurora in NIPR.

(2) *Meridian-scanning photometer*

Auroral emissions at the wavelengths of 557.7 nm (OI), 630.0 nm (OI) and 486.1 nm (H β) were observed by a meridian-scanning photometer installed in 1987. The interference filter for H β was tilted with 1 s period, measuring the Doppler effect of the auroral H β emission. The field of view of the photometer is 3° for OI 557.7 nm and 630.0 nm, and 5° for H β . A scan along a meridian from the poleward horizon to the equatorward horizon requires 30 s. Observations were carried out during clear nights from March 6 until September 27 in 1995. Calibration using a standard light source was executed at every observation night. The meridian-scanning photometer data were recorded with a digital data logger (TEAC DR-200) at a sampling frequency of 10-25 Hz through a line-approximate logarithmic amplifier, and monitored with a pen-recorder (6 ch RECTI-GRAPH). Due to a trouble in the instrument, both scanning and tilting angle data were not recorded.

4. Compiled Digital Tape Format

Data have been digitally recorded continuously since 1981. A similar recording system has been used in Iceland for the geomagnetic conjugate observations. The specifications of the compiled digital tapes are as follows:

Tracks : 9
 Record density : 6250 BPI
 Record format : FB
 Block length : 28848 bytes
 Logical record length : 48 bytes
 Label : Non-label
 Filing : Multi-file (1 file/day)

24 kinds of upper atmospheric data are recorded every 1 s in the following sequence:

<u>Word No.</u>	<u>Observation item</u>	<u>Word No.</u>	<u>Observation item</u>
1	H-component of magn. field	13	VLF 8 kHz
2	D-component of magn. field	14	VLF 30 kHz
3	Z-component of magn. field	15	VLF 60 kHz
4	H-component of ULF waves	16	VLF 95 kHz
5	D-component of ULF waves	17	NA
6	Z-component of ULF waves	18	NA
7	CNA (30 MHz)	19	NA
8	VLF 350 Hz	20	NA
9	VLF 750 Hz	21	NA
10	VLF 1.2 kHz	22	NA
11	VLF 2 kHz	23	NA
12	VLF 4 kHz	24	NA

Words 17-24 are dummy words. Each word, 12 bit A/D converted value, is recorded in the 2 byte binary form of signed 2's complement. A set of these 24 words makes a logical record of 48 bytes; the 10-min data make a block of 28848 bytes. A file contains one day of data (144 blocks) and a volume contains one month of data (28-31 files), as shown in Fig. 3. At the beginning of each block, the starting time of the observation period is written in the following format (48 bytes):

<u>Sequence</u>	<u>Item</u>	
1	Year	(2 bytes)
2	Total day	(2 bytes)
3	Hour	(2 bytes)
4	Minute	(2 bytes)
5	Station code	(4 bytes)
6	Space	(36 bytes)

The magnetic field data recorded on a compiled tape can be transformed to physical quantities by

the following relations:

H-component of the geomagnetic field variation (nT)	= DATA*2500/2048 – 1250
D- and Z-component of the geomagnetic field variation (nT)	= DATA*2500/2048
H-component of ULF waves (nT/s)	= DATA/141
D-component of ULF waves (nT/s)	= DATA/158
Z-component of ULF waves (nT/s)	= DATA/316

For CNA and VLF data, individual calibration values are required to obtain physical values from the recorded data. Inquiries on these calibration values should be addressed to the Upper Atmosphere Physics Research Division of NIPR. For more detailed information on the compiled data, see Uchida *et al.* (1988). These compiled data are also recorded on an Optical Disk (OD) at the sampling rate of 0.5 Hz together with the data from three Icelandic stations for conjugate studies. One volume of the OD can store the data obtained at the four stations during one year. Softwares to handle the OD data are also available to researchers. Details of the OD conjugate data base are described in Yamagishi (1990).

A computer system of the Information Science Center is available to collaborative researchers of NIPR. The center has also been providing various kinds of software such as tape-to-tape copy, displays and spectrum analysis program to the researchers.

Acknowledgments

We would like to acknowledge all the members of the 36th Japanese Antarctic Research Expedition (JARE-36) for their support to the upper atmosphere physics observations at Syowa Station. The publication of this report was supported by the Upper Atmosphere Physics Research Division, WDC-C2 for Aurora and the Information Science Center of the National Institute of Polar Research.

References

- Fujii, R., Sato, N. and Fukunishi, H. (1985): Upper atmosphere physics data, Syowa Station, 1982. JARE Data Rep., **105** (Upper Atmos. Phys. 2), 266p.
- Fujii, R., Kotake, N., Murata, I., Nozaki, K., Umetsu, M., Makita, K., Minatoya, H. and Yukimatu, A. (1994): Upper atmosphere physics (UAP) data obtained at Syowa and Asuka Stations in 1991. JARE Data Rep., **193** (Upper Atmos. Phys. 11), 208p.
- Kadokura, A., Uchida, K., Kurihara, N., Kimura, K., Okamura, H., Ariyoshi, H., Yukimatsu, A. and Ejiri, M. (1992): Upper atmosphere physics data, Syowa and Asuka Stations, 1989. JARE Data Rep., **171** (Upper Atmos. Phys. 9), 335p.

- Kikuchi, T., Ohwada, T., Oginasa, T., Uchida, K., Sakurai, H., Yamagishi, H. and Sato, N. (1988): Upper atmosphere physics data, Syowa Station, 1986. JARE Data Rep., 138 (Upper Atmos. Phys. 6), 276p.
- Miyaoka, H., Uchida, K., Mukai, H., Saito, H., Akamatsu, J., Shibuya, K., Sakai, R., Ayukawa, M. and Sato, N. (1990): Upper atmosphere physics data, Syowa and Asuka Stations, 1987. JARE Data Rep., 159 (Upper Atmos. Phys. 7), 306p.
- Obara, N., Wakino, Y., Kubota, M., Iwasaki, K., Nishimura, H. and Kadokura, A. (1996): Upper atmosphere physics data obtained at Syowa Station in 1994. JARE Data Rep., 209 (Upper Atmos. Phys. 14), 208p.
- Ono, T., Tsunomura, S., Ejiri, M., Fujii, R. and Sato, N. (1986): Upper atmosphere physics data, Syowa Station, 1984. JARE Data Rep., 118 (Upper Atmos. Phys. 4), 271p.
- Ono, T., Nakajima, H., Satoh, M., Ohtaka, K., Kawahara, M. and Kumade, A. (1993): Upper atmosphere physics data, Syowa and Asuka Stations, 1990. JARE Data Rep., 186 (Upper Atmos. Phys. 10), 222p.
- Sakurai, H., Shibasaki, K., Fujii, R. and Sato, N. (1985) : Upper atmosphere physics data, Syowa Station, 1983. JARE Data Rep., 108 (Upper Atmos. Phys. 3), 212p.
- Sato, N., Fujii, R., Fukunishi, H. and Nakajima, D. (1984): Upper atmosphere physics data, Syowa Station, 1981. JARE Data Rep., 93 (Upper Atmos. Phys. 1), 206p.
- Sato, N., Uchida, K., Saka, O., Yamaguchi, K., Iguchi, S., Aoki, T. and Miyaoka, H. (1991): Upper atmosphere physics data, Syowa and Asuka Stations, 1988. JARE Data Rep., 169 (Upper Atmos. Phys. 8), 212p.
- Tonegawa, Y., Rokuyama, K., Makita, Y., Yang H., Kadokura, A. and Sato, N. (1996): Upper atmosphere physics data obtained at Syowa Station in 1993. JARE Data Rep., 208 (Upper Atmos. Phys. 13), 202p.
- Uchida, K., Tonegawa, Y., Fujii, R. and Sato, N. (1988): Computer compilatory process of the data acquired by the conjugate observation system in Iceland. Nankyoku Shiryo (Antarct. Rec.), 32, 238-257 (in Japanese with English abstract).
- Yamagishi, H. (1990): Development of optical disk data base system for Syowa Station-Iceland geomagnetically conjugate observation. Nankyoku Shiryo (Antarct. Rec.), 34, 242-262 (in Japanese with English abstract).
- Yamagishi, H., Ayukawa, M., Matsumura, S., Sakurai, H. and Sato, N. (1987): Upper atmosphere physics data, Syowa Station, 1985. JARE Data Rep., 128 (Upper Atmos. Phys. 5), 272p.
- Yamazaki, I., Takahashi, Y., Mineno, H., Kamata, M., Ogawa, Y. and Kadokura, A. (1995): Upper atmosphere physics data obtained at Syowa Stations in 1992. JARE Data Rep., 205 (Upper Atmos. Phys. 12), 207p.

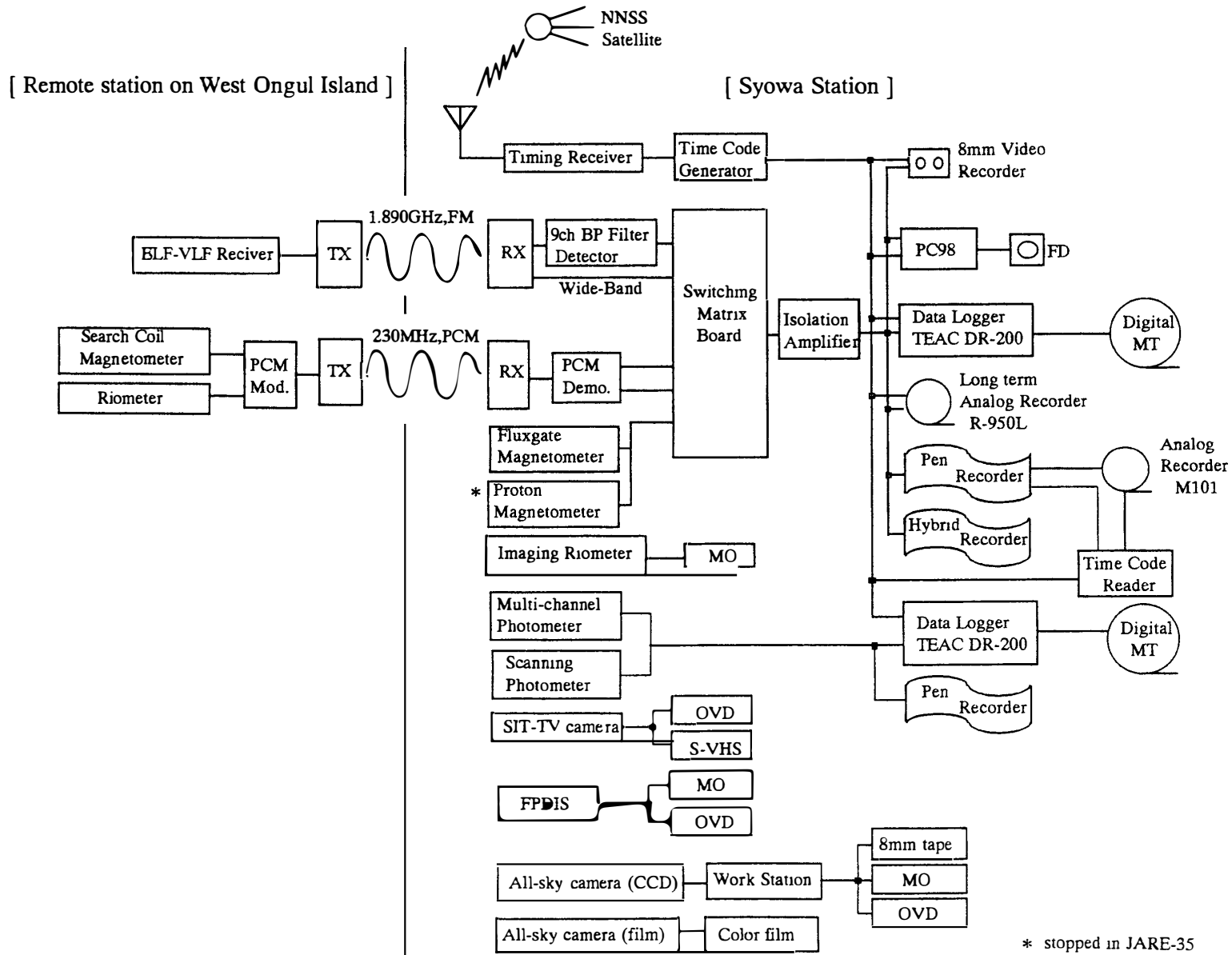

Fig. 1. Block diagram of the "Upper Atmosphere Physics" monitoring system at Syowa Station in 1995.

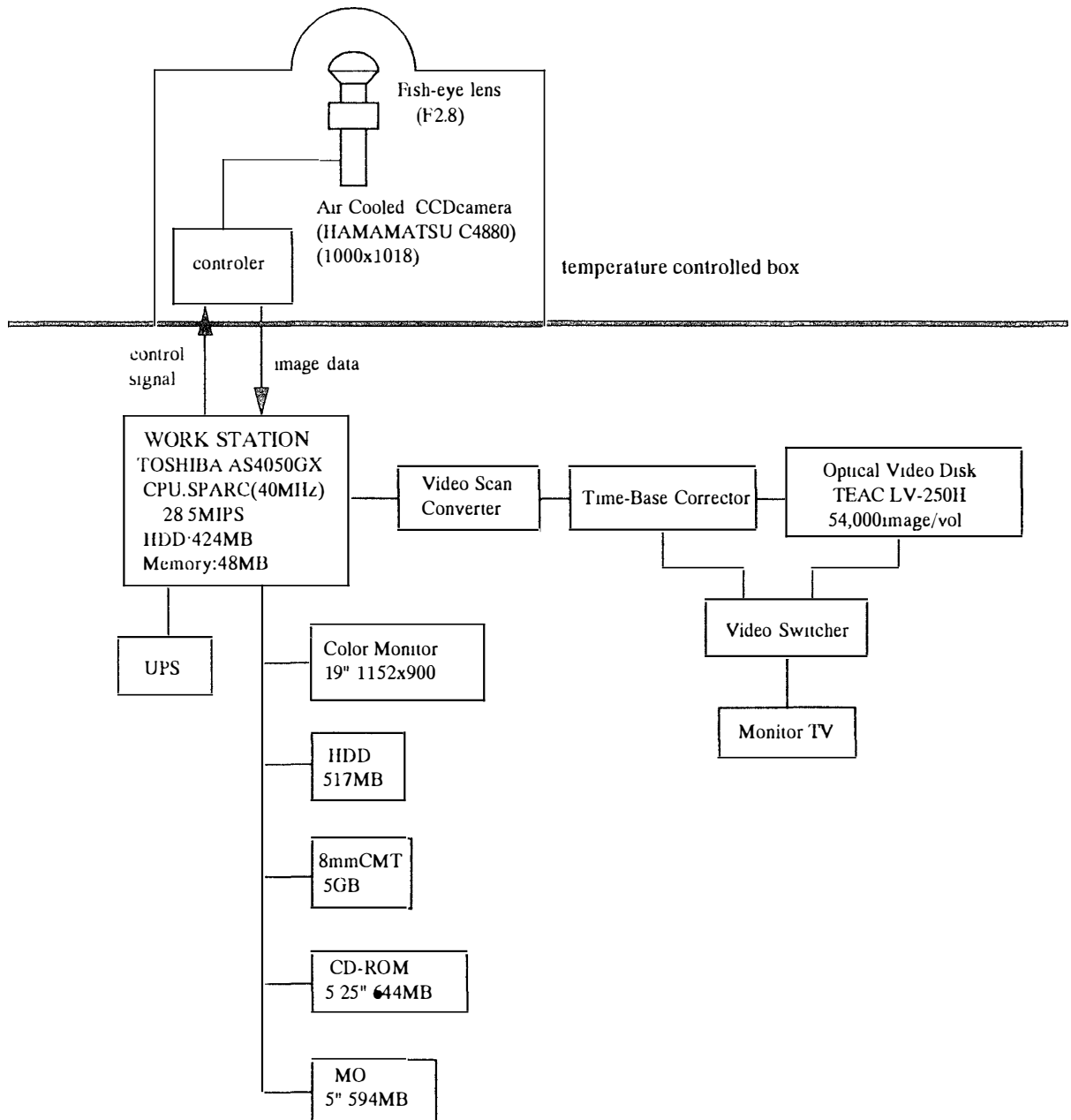

Fig. 2. Block diagram of the CCD all-sky camera observation system at Syowa Station in 1995.

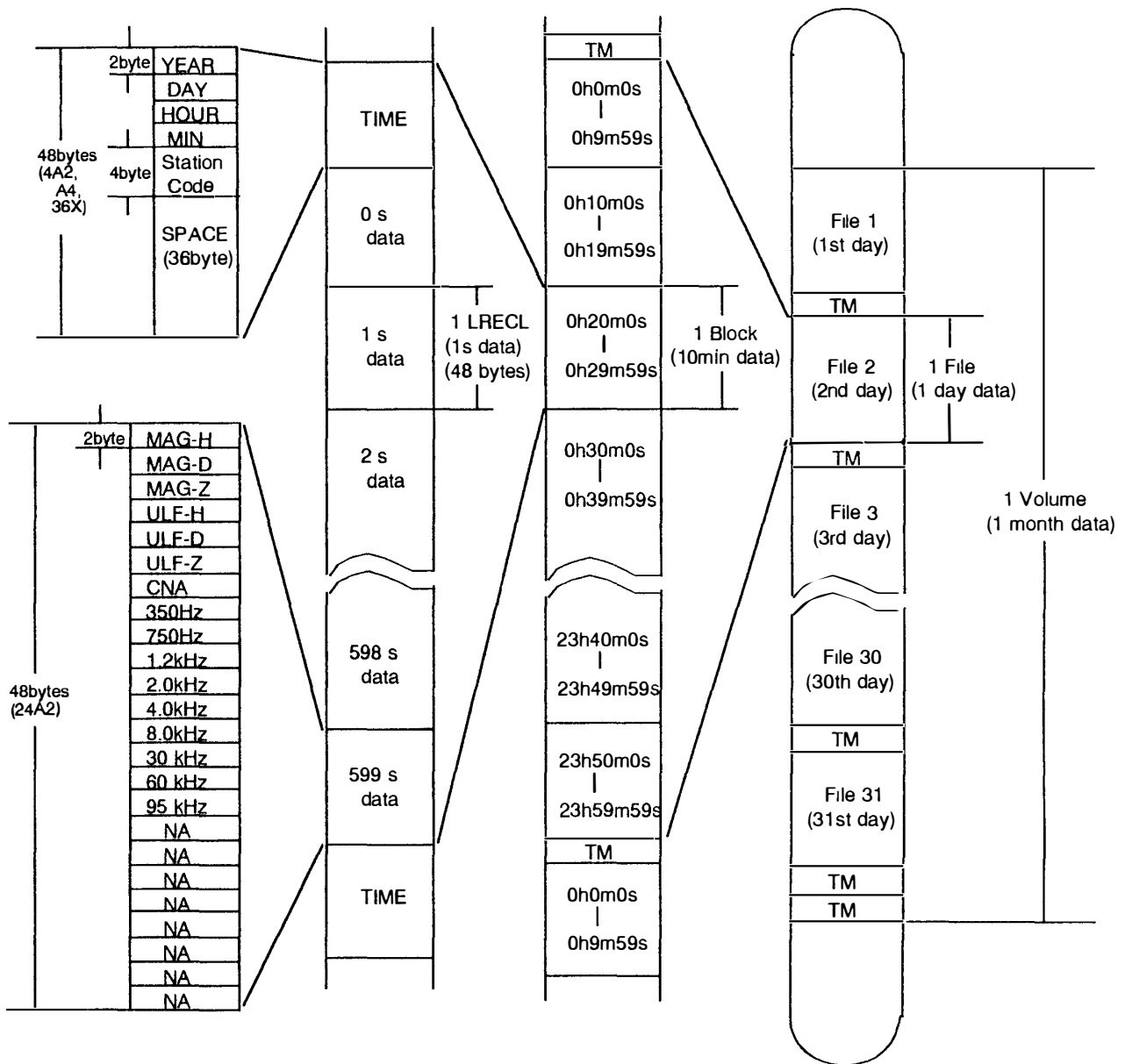

Fig. 3. The structure of the compiled digital tape format for Syowa Station in 1995.

Table 1. Baseline values of the geomagnetic field at Syowa Station in Feb. 1995 - Jan. 1996.

DATA	TIME (UT)	TOTAL INT. (nT)	HORI-ZONAL INT. (nT)	VERTICAL INT. (nT)	DECLINATION	DIP ANGLE
FEB. 23 1995	10h 21m	43627.1	19140.6	-39204.1	-47° 44.4'	-63° 58.6'
	10h 47m	43625.2	19089.8	-39226.7	-47° 44.4'	-64° 3.0'
	11h 39m	43620.5	19084.4	-39224.2	-47° 43.4'	-64° 3.3'
	12h 00m	43622.8	19083.1	-39227.4	-47° 42.6'	-64° 3.5'
	11h 27m	43623.9	19099.5	-39220.6	-47° 43.7'	-64° 2.1'
MAR. 23	10h 32m	43622.3	19096.7	-39220.2	-47° 53.3'	-64° 2.3'
	11h 15m	43614.8	19089.1	-39215.5	-47° 51.8'	-64° 2.7'
	12h 27m	43631.0	19084.2	-39235.9	-47° 49.1'	-64° 3.7'
	12h 56m	43639.8	19096.9	-39239.5	-47° 48.4'	-64° 2.9'
	11h 33m	43627.0	19091.7	-39227.8	-47° 50.6'	-64° 2.9'
APR. 19	10h 33m	43635.9	19108.6	-39229.5	-47° 50.2'	-64° 1.8'
	10h 48m	43639.1	19109.5	-39232.6	-47° 50.8'	-64° 1.8'
	11h 17m	43639.6	19111.9	-39231.9	-47° 49.9'	-64° 1.6'
	11h 38m	43639.0	19110.3	-39232.2	-47° 50.3'	-64° 1.7'
	11h 34m	43638.4	19110.1	-39231.6	-47° 50.3'	-64° 1.7'
MAY. 26	11h 32m	43633.2	19115.0	-39223.3	-47° 48.7'	-64° 1.1'
	12h 08m	43645.5	19105.6	-39241.7	-47° 48.3'	-64° 2.4'
	12h 47m	43640.6	19110.2	-39233.9	-47° 46.8'	-64° 1.8'
	13h 12m	43643.4	19117.5	-39233.5	-47° 46.8'	-64° 1.3'
	12h 25m	43640.7	19112.1	-39233.1	-47° 47.6'	-64° 1.6
JUN. 30	10h 18m	43645.2	19130.5	-39229.1	-47° 47.8'	-64° 0.2'
	10h 49m	43612.4	19101.9	-39206.7	-47° 47.3'	-64° 1.5'
	11h 15m	43635.8	19118.1	-39224.7	-47° 47.9'	-64° 0.9'
	11h 42m	43644.8	19121.2	-39233.3	-47° 47.1'	-64° 1.0'
	11h 31m	43634.6	19117.9	-39223.5	-47° 47.5'	-63° 0.9'
JUL. 30	10h 54m	43625.0	19126.1	-39208.8	-47° 50.0'	-63° 59.8'
	11h 31m	43628.4	19134.7	-39208.4	-47° 50.2'	-63° 59.2'
	12h 24m	43628.5	19129.1	-39211.3	-47° 50.2'	-63° 59.7'
	12h 55m	43628.0	19118.9	-39215.7	-47° 50.6'	-64° 0.6'
	11h 41m	43627.5	19127.2	-39211.1	-47° 50.2'	-63° 59.8'

DATA	TIME (UT)	TOTAL INT. (nT)	HORI- ZONAL INT. (nT)	VERTICAL INT. (nT)	DECLINATION	DIP ANGLE
AUG. 31 1995	11h 49m	43620.4	19126.6	-39203.5	-47° 51.3'	-63° 59.6'
	12h 15m	43620.7	19122.1	-39206.0	-47° 50.9'	-63° 60.0'
	12h 45m	43622.1	19123.0	-39207.1	-47° 51.4'	-63° 60.0'
	13h 08m	43622.8	19121.4	-39208.7	-47° 51.5'	-64° 0.1'
	12h 29m	43621.5	19123.3	-39206.3	-47° 51.3'	-63° 59.9'
SEP. 22	11h 34m	43618.8	19125.2	-39202.3	-47° 52.2'	-63° 59.6'
	12h 03m	43622.0	19119.5	-39208.7	-47° 52.0'	-64° 0.3'
	12h 39m	43619.5	19118.4	-39206.5	-47° 51.9'	-64° 0.3'
	13h 11m	43619.6	19117.0	-39207.2	-47° 52.0'	-64° 0.4'
	12h 22m	43620.0	19120.1	-39206.2	-47° 52.0'	-64° 0.1'
OCT. 25	12h 20m	43638.0	19127.7	-39222.5	-47° 51.1'	-64° 0.2'
	12h 55m	43644.2	19121.3	-39232.5	-47° 50.0'	-64° 1.0'
	13h 49m	43645.2	19131.2	-39228.9	-47° 50.5'	-64° 0.1'
	14h 26m	43648.0	19140.7	-39227.4	-47° 51.5'	-63° 59.4'
	13h 38m	43643.9	19130.2	-39227.8	-47° 50.8'	-64° 0.2'
NOV. 19	10h 21m	43607.1	19130.6	-39186.7	-47° 51.9'	-63° 58.7'
	10h 39m	43614.0	19132.8	-39193.3	-47° 51.6'	-63° 58.8'
	11h 12m	43614.6	19129.9	-39195.4	-47° 52.3'	-63° 59.1'
	11h 29m	43613.6	19133.2	-39192.7	-47° 52.8'	-63° 58.7'
	11h 25m	43612.3	19131.6	-39192.0	-47° 52.2'	-63° 58.8'
DEC. 29	10h 10m	43595.0	19134.5	-39171.4	-47° 54.8'	-63° 57.9'
	10h 26m	43592.2	19130.1	-39170.4	-47° 54.8'	-63° 58.2'
	10h 46m	43594.6	19127.7	-39174.2	-47° 54.8'	-63° 58.5'
	11h 07m	43595.3	19128.6	-39174.6	-47° 54.5'	-63° 58.4'
	10h 22m	43594.3	19130.2	-39172.6	-47° 54.7'	-63° 58.3'
JAN. 24 1996	12h 00m	43586.8	19094.9	-39181.6	-47° 52.9'	-64° 1.1'
	12h 26m	43589.9	19097.6	-39183.7	-47° 51.9'	-64° 1.0'
	13h 30m	43597.4	19109.5	-39186.3	-47° 51.5'	-64° 0.2'
	13h 49m	43597.8	19107.1	-39187.9	-47° 51.7'	-64° 0.4'
	13h 26m	43593.0	19102.3	-39184.9	-47° 52.0'	-64° 0.7'

Table 2. K-indices at Syowa Station in Feb. 1995 - Jan. 1996.

1995

1996

	FEBRUARY		MARCH		APRIL		MAY		JUNE		JULY		AUGUST		SEPTEMBER		OCTOBER		NOVEMBER		DECEMBER		JANUARY	
1	5432	2333	5644	3466	1110	0256	0000	0000	6645	4465	6542	1023	4121	1000	4010	0021	2111	0044	6663	3355	2211	4445	1112	1133
2	4533	4445	4643	3424	5622	3212	5542	4657	5533	4355	4200	0001	2100	0121	2100	0014	4122	3345	3643	3433	5222	3332	3221	1235
3	5443	4464	5211	1125	1010	0000	7665	4556	4654	3256	5211	1104	3231	2122	4210	0012	5523	3456	2222	1222	3111	2235	3321	2112
4	6533	4434	4111	2456	1110	0003	6653	3455	4122	1113	4310	1211	2110	0134	1111	0004	6564	5556	1112	5422	5532	2223	1112	2222
5	3221	1322	4322	3333	4323	1134	7665	4466	4311	0105	1110	0001	1011	1111	5432	3445	5433	3326	4312	4436	4111	1122	3222	2224
6	4421	2323	2421	0111	3310	0025	7444	3345	4211	0022	1000	0011	2100	0023	6333	3325	4533	3437	5442	3344	1211	2222	53*1	1112
7	5421	1225	1111	1111	5764	5866	4544	4347	5111	0033	3300	0000	1001	0224	5533	3434	5653	3335	4332	3132	2111	2111	2121	1123
8	5666	4322	2211	0111	5554	3445	7633	3234	3320	0000	2201	1000	6532	2164	5755	3434	6443	3454	3311	2223	1211	0112	2110	1132
9	2331	0111	1332	1256	6544	3425	5533	2235	0011	0110	1001	2121	5433	3445	5633	3213	3543	3345	2211	1222	4532	3223	1111	1123
10	1121	1214	7542	2334	5645	3335	3311	2122	4422	1101	0000	0000	5653	2214	2212	2245	3542	1111	3321	1123	4322	0113	4211	1133
11	5363	3454	6452	2467	2433	2255	4311	1014	4330	0001	1000	0002	3331	2224	7543	2446	3532	3424	3211	1235	3311	1122	1211	1133
12	4422	2456	6643	3357	6632	2234	4221	1032	0011	0000	2000	0000	5202	2123	4412	1246	4533	3235	3422	3343	1221	1343	2111	1114
13	6563	4446	6545	4535	3520	0025	2121	1103	0000	0002	2110	0000	5532	1124	4443	3335	4322	2333	1111	2221	2210	0121	4765	4423
14	6533	5455	5543	3345	4200	0113	3420	0131	1001	1024	2001	0124	7544	3345	4221	1144	3211	1124	4221	1123	4321	0223	3223	4346
15	5523	2345	4333	2136	1100	1010	0110	3114	2221	1011	2111	1111	5542	2234	6545	4432	3111	1114	2111	1111	3221	3444	6422	3234
16	3322	1423	4532	2244	1111	0022	4564	5466	5511	2242	2011	2546	4531	1211	3233	3125	2311	2344	2210	1114	5553	3222	3221	2333
17	2231	2212	3221	1123	4111	0000	5654	2244	4411	1103	4443	3425	3222	3342	4422	2121	2431	1213	4421	1123	2233	2443	4412	2345
18	4422	2233	2121	1012	1111	1143	4312	2126	1543	2114	5422	2122	2101	1134	0011	0014	3313	3445	1111	1133	3111	2122	3531	2343
19	2411	1133	2111	0123	4421	0013	4443	2334	4663	5445	3322	2124	4221	1025	2011	0013	6743	1123	3421	1234	4221	1332	2221	2336
20	4322	2232	2111	1222	2421	1122	5444	2235	4554	3324	5413	2112	4221	0111	3331	1223	3534	3444	4221	1223	1221	2211	3332	3322
21	3322	1123	1111	0111	0100	0000	4411	0003	3333	2223	0121	1011	1011	0000	3111	1134	4232	3335	3111	1223	1221	1444	2233	2224
22	2202	1111	1211	1112	1111	1334	3324	4005	3422	2212	2321	1123	1001	2056	2111	0013	3321	2344	3221	2324	4442	3464	3211	2233
23	1222	1233	1112	2342	5334	3447	4211	2266	3333	2111	5201	0233	5652	1112	5412	3345	5543	3364	4221	1223	4322	1122	4111	1111
24	1221	0213	3221	1123	6552	2346	4654	3335	2111	1110	3443	3155	3110	2133	4421	1113	5111	3343	2211	1122	4344	4435	1111	2333
25	1222	1112	4220	1114	6532	2233	5633	2233	0011	2354	6421	0002	5553	2335	2321	0111	4431	1111	2211	1113	3323	3343	2221	1233
26	3342	3344	3133	4545	3423	2225	4211	3344	6532	2136	4211	1113	3411	1012	2222	1023	1111	0124	2211	1112	4532	2344	5311	1323
27	3533	3455	5133	3345	3463	3233	2221	1220	3231	0014	3311	0034	4421	0033	4332	4576	3310	1224	2124	4455	5222	2232	4221	2224
28	6454	2366	6542	2444	4334	2213	2331	1124	3221	2225	3100	0004	0011	1212	3453	3111	1210	0123	2323	2244	1220	1222	4321	1234
29			5542	2235	5211	3234	2111	1133	2000	1111	5300	0114	5423	2124	2111	1012	3211	1112	4332	2323	2110	1233	5453	3333
30			4411	3222	2001	2004	3653	4455	4323	3477	4001	0034	4311	1002	2111	1014	1111	4543	5332	1112	3220	0112	46*1	1116
31			3112	1114			5545	3465			1230	0005	2001	0023			6632	2445			2231	2232	5311	2233

Table 3(a). Observation list of the CCD-type all-sky camera at Syowa Station in 1995.

8m/m tape ID	OVD			Start			End			Duration	Loss	Δt temp	
	ID	start	end	day	date	time	day	date	time			(sec)	(sec)
CCD950701	test obs.	19	196	183	95/07/02	03:37:00	183	95/07/02	05:00:00	1:23:00		30	10
CCD950702	941110	197	1616	183	95/07/02	13:48:00	183	95/07/02	22:46:00	8:58:00		30	15
CCD950703	941110	1617	3732	184	95/07/03	17:15:00	185	95/07/04	05:03:00	11:48:00		20	12
CCD950704	941110	3733	5854	185	95/07/04	13:48:00	186	95/07/05	05:03:00	15:15:00			
CCD950705-1	test obs.	5907	7919	186	95/07/05	13:50:00	187	95/07/06	05:03:00	15:13:00			
CCD950705-2	test obs.			186	95/07/05	13:50:00	186	95/07/06	05:03:00	15:13:00			
CCD950706	test obs.	7920	7929	187	95/07/06	13:55:00	188	95/07/07	05:05:00	15:10:00			
CCD950719	941110	7930	9170	200	95/07/19	21:50:00	201	95/07/20	04:43:20	6:53:20		20	13
CCD950720	941110	9171	11095	201	95/07/20	16:10:00	202	95/07/21	04:43:00	12:33:00		20	13
CCD950721	941110	11096	12739	202	95/07/21	17:41:00	203	95/07/22	04:32:00	10:51:00		20	13
CCD950722	941110	12740	15323	203	95/07/22	14:17:00	204	95/07/23	04:38:00	14:21:00		20	13
CCD950723	941110	15324	17895	204	95/07/23	14:19:00	205	95/07/24	04:36:00	14:17:00		20	13
CCD950724	941110	17896	20455	205	95/07/24	14:21:00	206	95/07/25	04:34:00	14:13:00		20	13
CCD950725	941110	20456	23003	206	95/07/25	14:23:00	207	95/07/26	04:32:00	14:09:00		20	13
CCD950726	941110	23004	25539	207	95/07/26	14:25:00	208	95/07/27	04:33:00	14:08:00			
CCD950727	941110	25540	27000	208	95/07/27	14:25:00	209	95/07/28	01:15:00	10:50:00		20	13
CCD950729	950728	2	2480	210	95/07/29	14:35:00	211	95/07/30	04:21:00	13:46:00		20	13
CCD950730	950728	2481	4948	211	95/07/30	14:37:00	212	95/07/31	04:19:00	13:42:00		20	13
CCD950731	950728	4949	7393	212	95/07/31	14:40:00	213	95/08/01	04:15:00	13:35:00		20	13
CCD950801	950728	7394	9812	213	95/08/01	14:43:00	214	95/08/02	04:09:00	13:26:00		20	13
CCD950802	950728	9813	12212	214	95/08/02	14:44:00	215	95/08/03	04:04:00	13:20:00		20	13
CCD950803	950728	12213	14583	215	95/08/03	14:50:00	216	95/08/04	04:00:00	13:10:00		20	13
CCD950804	950728	14584	16931	216	95/08/04	14:53:00	217	95/08/05	03:55:40	13:02:40		20	13
CCD950806	950728	16932	19234	218	95/08/06	14:58:00	219	95/08/07	03:45:20	12:47:20		20	13
CCD950809	950728	19235	21533	221	95/08/09	15:03:00	222	95/08/10	03:49:00	12:46:00		20	13
CCD950810	950728	21534	23556	222	95/08/10	15:52:00	223	95/08/11	03:06:00	11:14:00		20	13
CCD950812	950728	23557	25755	224	95/08/12	15:12:00	225	95/08/13	03:25:00	12:13:00		20	13
CCD950814	950814	2	717	226	95/08/14	16:15:00	226	95/08/14	20:13:00	3:58:00		20	13
CCD950815	950814	718	1638	227	95/08/15	19:10:00	228	95/08/16	00:17:00	5:07:00		20	13
CCD950816	950814	1639	2532	228	95/08/16	15:24:00	228	95/08/16	20:22:00	4:58:00		20	13
CCD950817	950814	2533	4638	229	95/08/17	15:27:00	230	95/08/18	03:29:00	12:02:00		20	13
CCD950818	950814	4639	6601	230	95/08/18	15:30:00	231	95/08/19	02:24:00	10:54:00		20	13
CCD950820	850814	6603	8646	232	95/08/20	15:36:00	233	95/08/21	03:11:00	11:35:00		20	13
CCD950821	950814	8647	10226	233	95/08/21	18:15:00	234	95/08/22	03:08:00	8:53:00		20	13
CCD950822	950814	10247	12281	234	95/08/22	15:43:00	235	95/08/23	03:14:35	11:31:35		20	13
CCD950823	950814	12282	14307	235	95/08/23	15:46:00	236	95/08/24	03:01:00	11:15:00		20	13
CCD950824	950814	14308	16304	236	95/08/24	15:50:00	237	95/08/25	02:55:00	11:05:00		20	13
CCD950825	950814	16305	16756	237	95/08/25	15:53:00	237	95/08/25	18:23:00	2:30:00		20	13
CCD950826	950814	16757	17681	238	95/08/26	15:57:00	238	95/08/26	21:05:00	5:08:00		20	13
CCD950827	950814	17682	17982	239	95/08/27	16:05:00	240	95/08/28	02:43:00	10:38:00		20	13
CCD950829	950814	17983	18247	242	95/08/30	01:15:00	242	95/08/30	02:43:00	1:28:00		20	13
CCD950830	950814	18248	20025	242	95/08/30	16:30:00	243	95/08/31	02:23:00	9:53:00		20	13
CCD950831	950814	20026	21855	243	95/08/31	16:16:00	244	95/09/01	02:27:00	10:11:00		20	13
CCD950901	950814	21860	22444	244	95/09/01	16:20:00	244	95/09/01	19:35:00	3:15:00		20	13
CCD950902	950814	22445	23625	245	95/09/02	16:24:00	246	95/09/03	02:18:00	9:54:00		20	13
CCD950903	950814	23626	25381	246	95/09/03	16:28:00	247	95/09/04	02:13:00	9:45:00		20	13
CCD950904	950904	3	1718	247	95/09/04	16:32:00	248	95/09/05	02:04:00	9:32:00		20	13
CCD950905	950904	1719	3421	248	95/09/05	16:36:00	249	95/09/06	02:03:00	9:27:00		20	13
CCD950906	950904	3422	5068	249	95/09/06	16:50:00	250	95/09/07	01:59:00	9:09:00		20	13
CCD950907	950904	5069	6712	250	95/09/07	16:45:00	251	95/09/08	01:53:00	9:08:00		20	13
CCD950908	950904	6713	7003	251	95/09/08	16:49:00	251	95/09/08	18:26:00	1:37:00		20	13
CCD950911	950904	7004	8456	254	95/09/11	17:03:00	255	95/09/12	01:31:00	8:28:00		20	13
CCD950912	950904	8457	9566	255	95/09/12	18:50:00	256	95/09/13	01:00:00	6:10:00		20	13
CCD950913	950904	9567	11031	256	95/09/13	17:13:00	257	95/09/14	01:21:00	8:08:00		20	13
CCD950918	950904	11032	11714	261	95/09/18	20:50:00	262	95/09/19	01:00:00	4:10:00		20	13
CCD950919	950904	11715	11892	262	95/09/19	23:58:00	263	95/09/20	00:57:00	0:59:00		20	13
CCD950920	950904	11893	13112	263	95/09/20	18:02:00	264	95/09/21	00:48:00	6:46:00		20	13
CCD950921	950904	13113	14329	264	95/09/21	18:00:00	265	95/09/22	00:45:00	6:45:00		20	13
CCD950922	950904	14330	15493	265	95/09/22	18:08:00	266	95/09/23	00:45:00	6:37:00		20	13
CCD950923	950904	15494	16613	266	95/09/23	18:15:00	267	95/09/24	00:45:00	6:30:00		20	13
CCD950924	950904	16614	17685	267	95/09/24	18:23:00	268	95/09/25	00:20:00	5:57:00		20	13
CCD950925	950904	17686	18691	268	95/09/25	18:23:00	269	95/09/26	00:20:00	5:57:00		20	13
CCD950926	950904	18692	19859	269	95/09/26	17:42:00	270	95/09/27	00:11:00	6:29:00		20	13
CCD950927	950904	19860	20862	270	95/09/27	18:26:00	271	95/09/28	00:00:00	5:24:00		20	13
CCD950929	950904	20863	21807	272	95/09/29	18:40:00	273	95/09/30	00:03:20	5:33:20		20	13
CCD950930	950904	21808	22676	273	95/09/30	18:50:00	273	95/09/30	23:40:00	4:50:00		20	13
CCD951004	950904	22677	23117	277	95/10/04	19:12:00	277	95/10/04	21:39:00	2:27:00		20	13
CCD951006	950904	23118	23694	279	95/10/06	19:28:00	279	95/10/06	22:40:00	3:12:00		20	13

Table 3(b). Observation periods of a 35 mm film-type all-sky camera at Syowa Station in 1995.

Date	Hours (Universal Time)									K-Index	
	h	m	s	h	m	s	h	m	s		
MAR. 6				19	00	00	-23	00	00	2421	0111
7				19	00	00	-23	00	00	1111	1111
11							22	00	00	6452	2467
12	-00	00	00				19	00	00	6643	3357
13	-00	00	00				18	30	00	6545	4535
14	-00	30	00							5543	3345
19							19	22	00	2111	0123
20	-00	03	30				18	31	00	2111	1222
21	-02	30	30				18	00	00	1111	0111
22	-01	08	30				18	01	00	1211	1112
23	-01	09	30							1112	2342
25							19	01	00	4220	1114
26	-01	09	30	18	01	00	-22	53	30	3133	4545
26							23	52	00		
27	-01	39	30				17	40	30	5133	3345
28	-01	39	30							6542	2444
29							17	30	30	5542	2235
30	-01	39	30				17	30	30	4411	3222
31	-01	39	30							3112	1114
APR. 2							17	30	30	5622	3212
3	-01	39	30							1010	0000
4							17	30	30	1110	0003
5	-02	09	30				17	00	30	4323	1134
6	-02	09	30				16	41	00	3310	0025
7	-02	15	30				17	09	00	5764	5866
8	-02	14	30				16	33	00	5554	3445
9	-02	15	30				16	30	00	6544	3425
10	-00	54	30				16	30	00	5645	3335
11	-02	14	30				16	21	30	2433	2255
12	-02	30	30				16	16	30	6632	2234
13	-02	35	30				16	16	30	3520	0025
14	-02	35	00							4200	0113
19							15	48	30	4421	0013
20	-03	01	30							2421	1122
26							15	22	00	3423	2225
27	-03	25	30							3463	3233

Date	Hours (Universal Time)									K-Index	
	h	m	s	h	m	s	h	m	s		
APR. 30							15	52	00	2001	2004
MAY 1	-00	36	00	00	41	00	-03	34	30	0000	0000
1							14	03	30		
2	-00	07	00	00	23	00	-03	40	30	5542	4657
5							22	43	00	7665	4466
6	-03	52	00							7444	3345
10	14	37	00	-18	10	00	18	21	00	3311	2122
11	-04	06	30							4311	1014
12				18	09	30	-18	33	30	4221	1032
14							14	26	00	3420	0131
15	-04	16	30				14	26	30	0110	3114
16	-04	16	30				14	21	30	4564	5466
17	-04	22	30							5654	2244
18							17	00	30	4312	2126
19	-03	42	00	14	14	30	-17	41	00	4443	2334
20				14	12	30	-19	43	00	5444	2235
21				19	18	00	-21	03	30	4411	0003
22				17	38	30	-20	28	00	3324	4005
23							14	06	30	4211	2266
24	-04	30	30				14	04	30	4654	3335
25	-04	39	30				14	02	30	5633	2233
26	-00	21	00	02	44	00	-04	41	30	4211	3344
26							14	00	30		
27	-04	43	30				13	59	30	2221	1220
28	-04	45	30				13	57	00	2331	1124
29	-04	46	30							2111	1133
30	00	21	00	-04	48	30	22	30	00	3653	4455
31	-00	54	30				17	34	30	5545	3465
JUN. 1	-04	52	30				16	02	00	6645	4465
2	-04	52	30	13	49	00	-23	12	30	5533	4355
3							17	45	30	4654	3256
4	-01	23	30							4122	1113
5	00	17	00	-05	00	30				4311	0105
5				16	22	00	-23	50	30		
6							13	45	30	4211	0022
7	-02	59	30	03	00	00	-05	02	00	5111	0033
7							13	44	00		
8	-05	04	00				13	43	00	3320	0000
9	-05	04	30	13	43	30	-20	54	30	0011	0110

Date	Hours (Universal Time)									K-Index	
	h	m	s	h	m	s	h	m	s		
JUN. 9							22	32	00		
10	-05	05	30				22	32	30	4422	1101
11	-05	05	30				13	41	30	4330	0001
12	-05	07	30				13	41	30	0011	0000
13	-05	07	30	13	41	30	-22	45	30	0000	0002
14							13	41	00	1001	1024
15	-05	07	30	13	41	30	-18	26	00	2221	1011
16							13	41	00	5511	2242
17	-05	07	30				13	41	30	4411	1103
18	-13	42	30				14	02	30	1543	2114
19	-05	07	30				13	40	30	4663	5445
20	-05	12	30				13	40	30	4554	3324
21	-05	12	30	13	40	30	-20	44	00	3333	2223
21							23	31	00		
22	-05	12	30	13	40	00	-20	59	30	3422	2212
22							21	00	00		
23	-05	12	30							3333	2111
24	13	40	00	-18	17	00				2111	1110
25							18	46	00	0011	2354
26	-05	13	00				13	41	00	6532	2136
27	-05	12	30							3231	0014
28							13	43	00	3221	2225
29	-05	10	30				13	43	30	2000	1111
30	05	10	30							4323	3477
JUL. 1							13	47	30	6542	1023
2	-05	09	30	13	50	30	-20	39	30	4200	0001
6							13	55	00	1000	0011
7	-05	09	30				13	55	30	3300	0000
8	-05	09	30	13	55	30	-23	54	30	2201	1000
9				13	55	00	-16	17	00	1001	2121
13							20	10	30	2110	0000
14	-05	04	30				14	01	00	2001	0124
15	-05	00	30				14	03	30	2111	1111
16	-05	00	30				14	05	30	2011	2546
17	-03	40	00				22	18	30	4443	3425
18	-05	00	30	14	09	30	-16	56	00	5422	2122
18							23	21	00		
19	-04	55	30				14	10	30	3322	2124
20	-04	55	30							5413	2112

Date	Hours (Universal Time)									K-Index	
	h	m	s	h	m	s	h	m	s		
JUL. 20							14	12	30		
21	-04	47	30				14	12	30	0121	1011
22	-04	47	30	14	17	30	-17	55	00	2321	1123