

Deep ice core drilling to 2503 m depth at Dome Fuji, Antarctica

Yoshiyuki Fujii¹, Nobuhiko Azuma², Yoichi Tanaka³, Yoshiki Nakayama⁴,
Takao Kameda⁵, Kunio Shinbori⁶, Kazuo Katagiri², Shuji Fujita⁷,
Akiyoshi Takahashi⁸, Kunio Kawada⁹, Hideaki Motoyama¹, Hideki Narita⁶,
Kokichi Kamiyama¹, Teruo Furukawa¹, Shuhei Takahashi⁵, Hitoshi Shoji⁵,
Hiroyuki Enomoto⁵, Takeshi Saitoh⁶, Morihiro Miyahara⁸, Renji Naruse⁶,
Takeo Hondoh⁶, Takayuki Shiraiwa⁶, Kotaro Yokoyama¹⁰, Yutaka Ageta¹¹,
Takashi Saito¹² and Okitsugu Watanabe¹

¹National Institute of Polar Research, Kaga 1-chome, Itabashi-ku, Tokyo 173-8515

²Nagaoka University of Technology, 1603-1, Kamitomioka-cho, Nagaoka 940-2188

³Geosystems Inc., SDC Nanyodo Bldg, 14-4, Hongo 1-chome, Bunkyo-ku, Tokyo 113-0033

⁴Nihon Public Engineering Co. Ltd., Sano Bldg, 45-19, Higashi Kasai 6-chome,
Edogawa-ku, Tokyo 134-0084

⁵Kitami Institute of Technology, 165, Koencho, Kitami 090-8507

⁶Institute of Low Temperature Science, Hokkaido University, Kita-19,
Nishi-8, Kita-ku, Sapporo 060-0819

⁷Graduate School of Engineering, Hokkaido University, Sapporo 060-0013

⁸Geo Tecs Co. Ltd., 1-5-14, Kanayama, Naka-ku, Nagoya 460-0022

⁹Center for Far Eastern Studies, Toyama University, 3190, Gofuku, Toyama 930-0887

¹⁰Hokuriku Research Center, National Institute for Agro-Environmental Sciences,
2-1, Inada 1-chome, Joetsu 943-0193

¹¹Graduate School of Environmental Studies, Nagoya University,
Furocho, Chikusa-ku, Nagoya 464-0814

¹²Disaster Prevention Research Institute, Kyoto University, Gokasho, Uji 611-0011

Abstract: Deep ice core drilling was carried out at Dome Fuji, Antarctica in 1995 and 1996 from the bottom of the casing installed in 1993 and reached 2503.52 m in December 1996. We used a JARE type electromechanical drill with a core barrel of 2.2 m length. Total numbers of ice corings and chip collections were 1369 and 837 respectively. The mean coring depths per run and per day were 1.75 m and 8.21 m, respectively. Quality of ice cores was perfect throughout the whole depth, even in the brittle zone. We report the outline of the system, coring performance, and troubles encountered.

1. Introduction

As a part of PICE (Paleoenvironments from Ice Cores) of PAGES (Past Global Changes), a core project of IGBP (International Geosphere-Biosphere Programme), JARE (Japanese Antarctic Research Expedition) carried out the Dome Fuji Project, a comprehensive glaciological study, to clarify present and past glaciological/climatological features of the Antarctic ice sheet in east Dronning Maud Land (Dome-F Ice Coring Group, 1999).

JARE conducted ice core drilling to a depth of 700.56 m at Mizuho Station in 1984 with a thermal drill but the core drilled from depths deeper than 96 m had many cracks at about 5 mm intervals (Narita *et al.*, 1994) due to thermal stress during ice core drilling. Considering energy consumption, transportation load and ice core quality, we selected an electromechanical drill as the type to develop for the Dome Fuji Project (Tanaka *et al.*, 1994).

Deep ice core drilling at Dome Fuji (77°19'01"S, 39°42'12"E and 3810 m a.s.l.) started in August 1995 and reached 2503.52 m in depth in December 8, 1996. The outline of deep ice core drilling and the in-situ core analyses was presented elsewhere (Dome-F Deep Coring Group, 1997). In this paper, we describe details of the system, the performance and the troubles.

2. Facilities and system

2.1. Drill site

The drilling and the related facilities are shown in Fig. 1. They consist of a drill site, a science cave, a drill control room, a core storage cave, a borehole liquid storage cave and a drill workshop. The drill site is a trench, 22 m (L)×4 m (W)×4 m (H) (Fig. 2; Takahashi and Azuma, 1994). The roof and the wall were insulated with 10 and 5 cm thick insulators respectively. The temperature at the drill site was -40 to -50°C in 1995 but was kept in the range -25 to -35°C in 1996 even in winter when the outside air temperature dropped below -70°C by idling a generator engine even at night and ventilating with warm air from the engine room (drill workshop) to the drill site.

A science cave, 23 m (L)×2 m (W)×2 m (H), was excavated perpendicularly to the drill trench. A core processing desk was set along the cave wall with 23 m (L)×0.9 m (W)×0.9 m (H). The temperature in the cave was kept around -25°C by ventilating

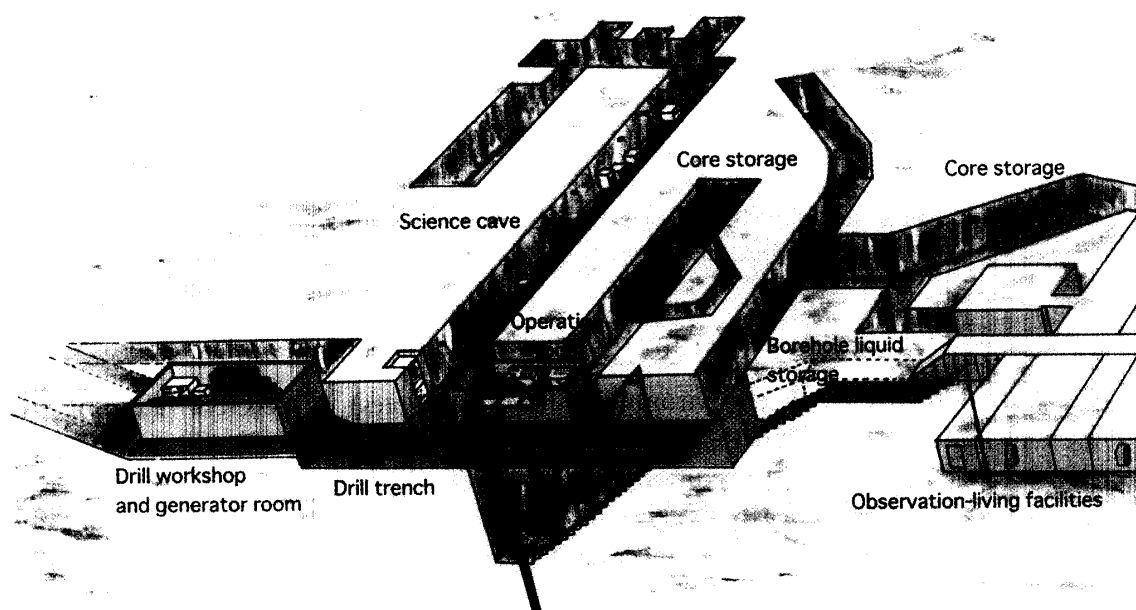

Fig. 1. A Bird's-eye-view of the drilling and related facilities at Dome Fuji Station.

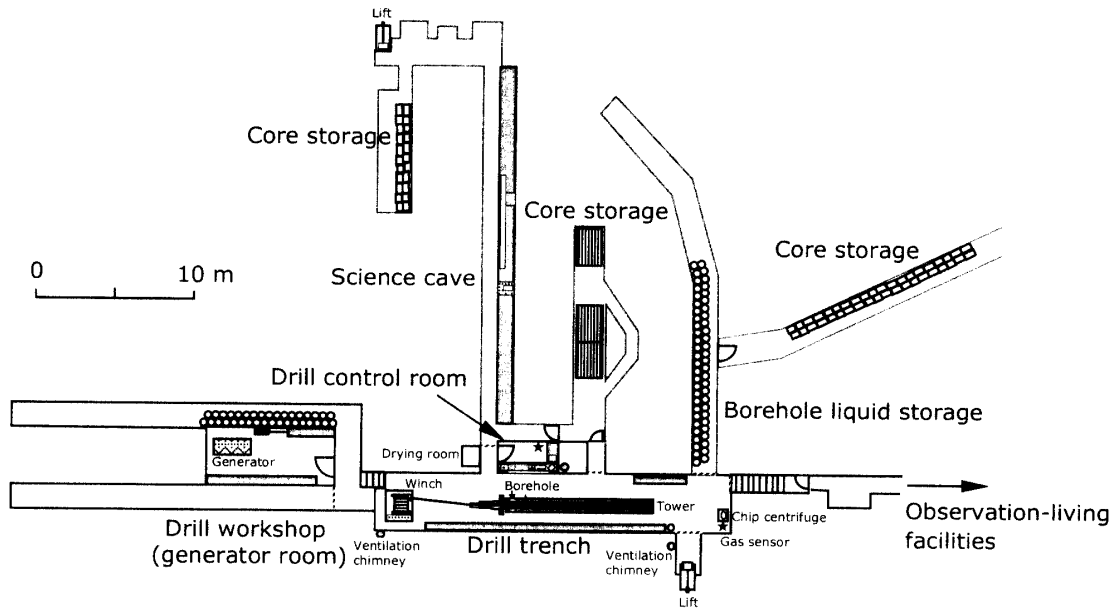

Fig. 2. Drilling and related facilities at Dome Fuji Station.

Table 1. Specifications of JARE deep drill.

No.*	Name of parts	Specifications
1	Shoe	Changeable from 2 to 3 mm in pitch.
2	Cutter	Rake angle; 15°, 30° and 40°. DC53 and ATT.
3	Core catcher	Block and dog leg types.
4	Cutter mount	JIS SKTM 18 stainless steel.
5	Outer jacket	2272 mm (L) × 122 mm (φ) × 3.5 mm (T), SUS304TP.
6	Core barrel	2321 mm (L) × 101.6 mm (φ) × 2.1 mm (T), SUS304.
7	Archimedian pump	15 mm (W) × 6.2 mm (T), High density polyethylene.
8	Booster screw	112 mm (φ), 100 mm (pitch), SUS304.
9	Drive shaft	3230 mm (L) × 34 mm (φ) × 3.4 mm (T), SUS304.
10	Chip chamber	3260 mm (L) × 122 mm (φ) × 3.5 mm (T), SUS304.
11	Filter	110 mm (φ), nylon and stainless steel nets.
12	Liquid outlet	4 outlets. 30 mm in diameter.
13	Shaft coupler	One touch coupler.
14	Reduction gear	Planetary type. 1/170, 175 mm(L) × 80 mm (φ).
15	Motor	DC brushless motor. 270 V, 600 W, 12000 rpm, 0.48 Nm.
16	Drill computer	Motor drive and signal transfer.
17	Pressure tight tube	1412 mm (L) × 122 mm (φ) × 11 mm (T), 30 MPa.
18	Linear electric contact	Stroke length 100 mm. Max. 5 A.
19	Anti torque	Leaf spring type. 640 mm (L) × 25 mm (W) × 2.5 mm (T).
20	Slip ring	4 poles. Max 5 A for 2 poles and 0.3 A for 2 poles.
21	Cable grip	Product of PMI Co.
22	Cable	7.72 mm (φ). 7 conductors.

* Numbers correspond to those in Fig. 3.

warm air from a generator room and heating with a 1.5 kW heater.

The drill control room was constructed in front of the drill tower in the drill trench. The size was 3.6 m (L)×2.7 m (W)×2.4 m (H). A large double-plastic window was convenient for communication between a driller inside and a helper outside at the beginning and end of drill up/down operation. The room temperature was kept around +20°C using two 1.5 kW heaters.

2.2. Drill

Tanaka *et al.* (1994) described the development of a JARE deep ice core drilling system. The drill was designed to have low energy consumption, low transportation load, cold-resistant performance at -60°C and capability of operation by a few men (Fujii *et al.*, 1990). Specifications of the drill used at Dome Fuji are summarized in Table 1.

The drill was electromechanical and the schema is shown in Fig. 3. It consists of a

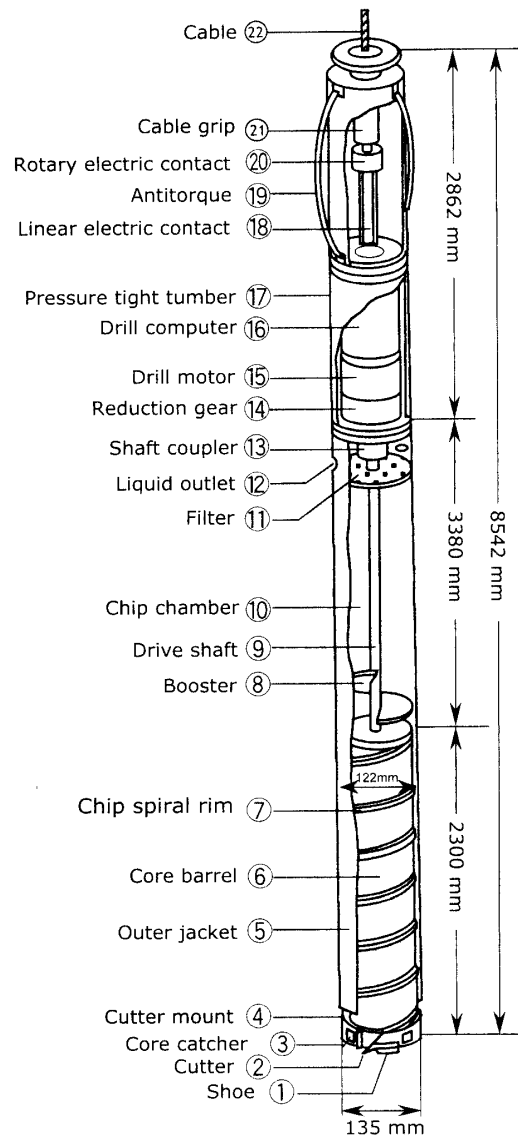

Fig. 3. Schematic of a JARE deep ice coring drill.

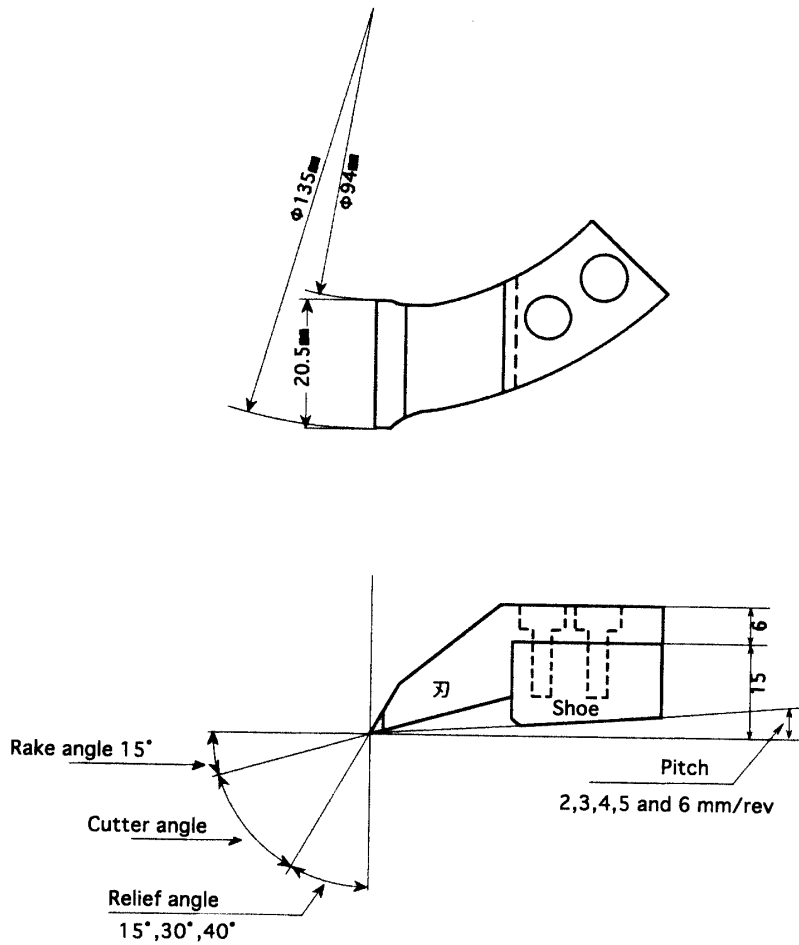

Fig. 4. Schematic of a drill cutter.

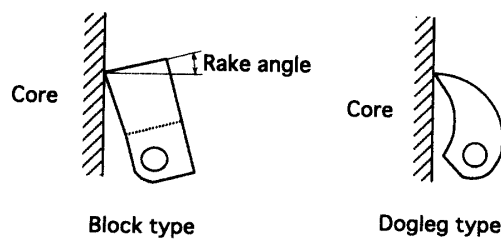

Fig. 5. Schematic of two types of core catcher.

core barrel, a chip chamber, a pressure tight section, and an anti-torque section. Three cutters are attached to cut an ice core 94 mm in diameter and a borehole 135 mm in diameter (Fig. 4). We prepared three types of cutter with rake angles of 15, 30 and 40°. The maximum core length is 2.2 m. We prepared block and dogleg type core catcher (Fig. 5). Chips are transported through the space between the core barrel and the outer jacket by three spiral rims attached to the core barrel. The chips are separated from liquid with a filter at the top of the chip chamber, and are compacted to the density of 500 kg/m³. In the pressure tight section, a drill computer, DC brushless motor (270 V, 600 W, 12000 rpm)

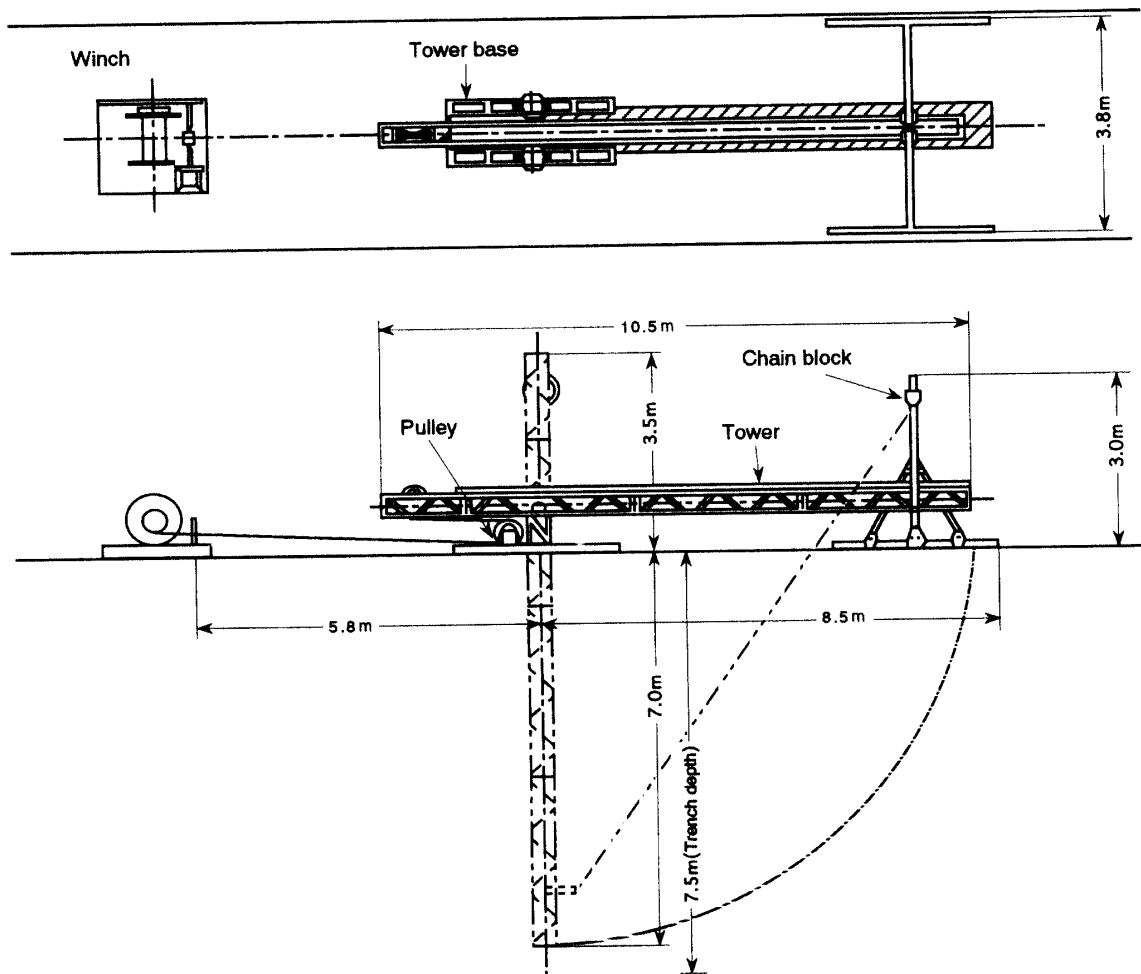

Fig. 6. Schematic of a tower and a winch.

and a planetary reduction gear (1/170) are installed. The anti-torque section consists of three leaf springs.

2.3. Tower and Winch

Figure 6 shows the tower and winch with a 3500 m long armored cable. At the drill site, a narrow trench 8 m deep was dug to rotate a tower from horizontal position for core extraction and drill maintenance to the vertical position for drilling. The total weight including the 3500 m long cable is 2345 kg. We used an inverter motor (Toshiba VF-V3; 11 kW, 200 V, 3-phase driven by an inverter) as a winch motor, which has constant torque of 70.1 N m for motor pivot from 0 to 1500 rpm. This motor torque satisfies the required maximum torque of 50 N m for a hoisting speed of 52 m/min at 3000 m in depth. The winch speed can be controlled from 0 to 90 m/min when hoisting and lowering the drill and to a speed as slow as 1 cm/min using a vernier dial when ice core drilling.

2.4. Cable

A steel armored cable of 7.72 mm diameter with seven conductors was used. Weight in air is 246 kg/km. The DC resistance of one conductor is 54.4 Ω /km and of armor is

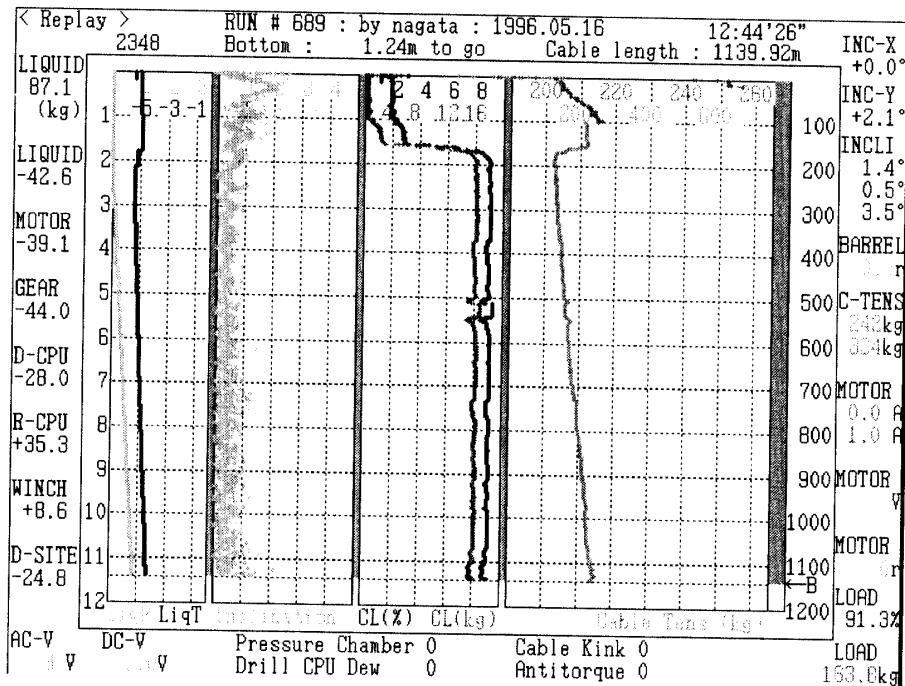

Fig. 7. Monitor display during drill descent.

9.5 Ω /km. The breaking strength is 37.4 kN, and the working load is 14.7 kN. We used two conductors for communication between a drill computer installed in a pressure tight chamber and a relay computer at the surface, and five conductors tied up in one and the outer armored cable for DC supply to a drill motor.

2.5. Monitor

We monitored 30 items such as liquid pressure, liquid temperature, motor temperature, reduction gear temperature, cable length, distance from borehole bottom, cable tension, drill inclination (X and Y), average and maximum inclination, supply voltage, motor voltage, motor electric current, motor rotation rate, cutter load and so on. All sensor data are sent through a relay computer to a personal computer and displayed on a CRT as shown in Fig. 7. The data on CRT display were updated every second and saved on a hard disk.

2.6. Borehole liquid

As the mean annual air temperature at Dome F was estimated to be -58°C from the 10 m snow temperature observed by Ageta *et al.* (1989) in 1985, viscosity of borehole liquid is considered to be an important factor. We selected n-butyl acetate as the borehole liquid from various candidates (Fujita *et al.*, 1994) because of its low viscosity at an ice temperature as low as -60°C . The other reason is its density which is close to that of ice. This means that the use of n-butyl acetate does away with the need for a densifier (Wumkes, 1994).

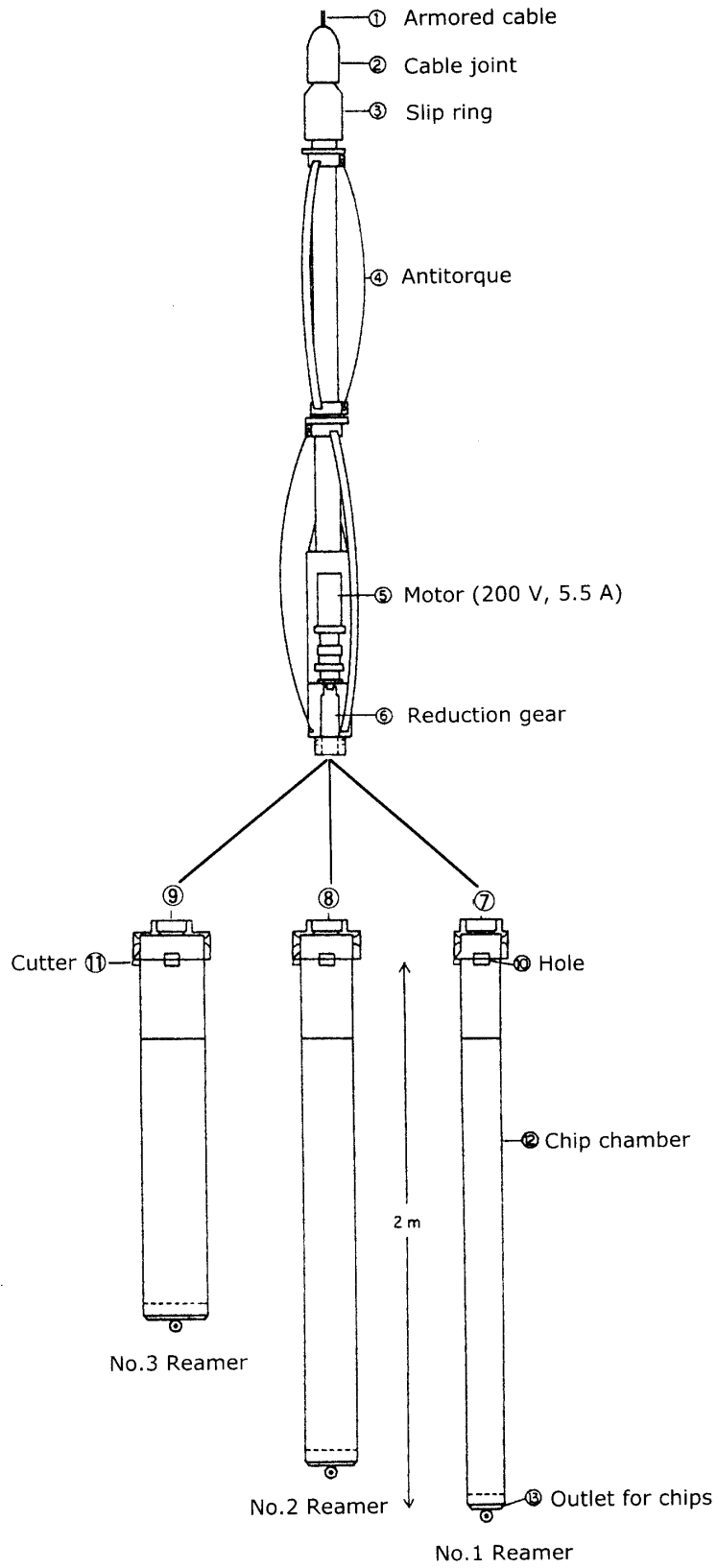

Fig. 8. Schematic of a reamer.

3. Performance

3.1. Casing

A special fiberglass casing was used. This casing was used at GRIP, Greenland (Johnsen *et al.*, 1994) and at Low Dome, Antarctica (Morgan *et al.*, 1994). The casing has an inside diameter of 200 mm and requires a 254 mm borehole to be installed. The casing was installed in 1993, two years prior to starting deep ice core drilling, to a depth of 84.5 m after reaming the borehole to 135 mm in diameter with three reamers with diameters of 180, 221 and 254 mm as shown in Fig. 8 (Motoyama *et al.*, 1995). We aimed to install the casing to a depth of 100 m, but deposition of spilled chips from the chip

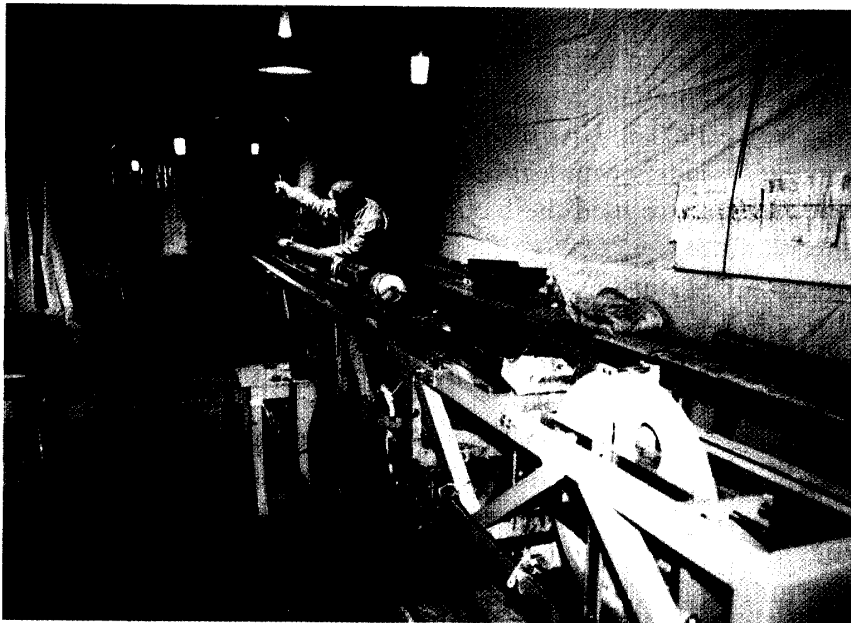

Fig. 9. Check of drill before lowering for ice core drilling.

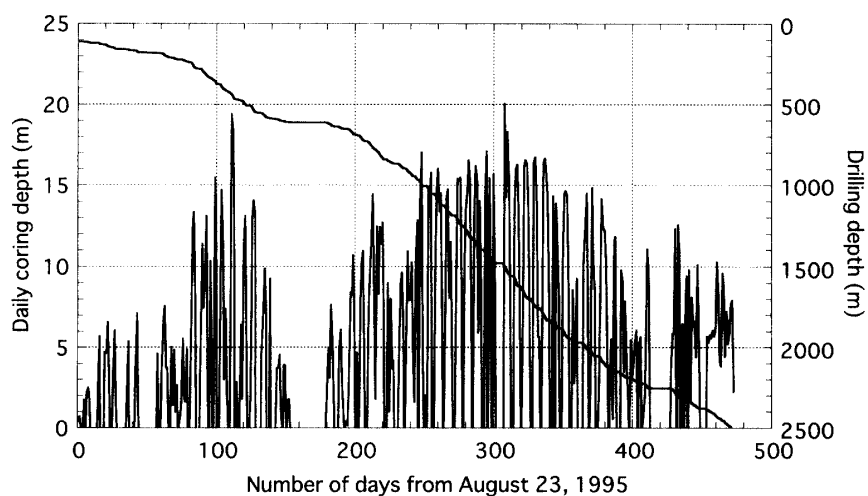

Fig. 10. Progress of ice core drilling; daily core drilling and borehole depths from August 23, 1995.

chamber during reaming made installation to 100 m depth difficult.

Prior to the deep ice core drilling in 1995, the casing was sealed at the bottom by refreezing wet snow to prevent the drill from catching against the bottom end of the casing when hoisting the drill.

3.2. *Drilling and chip collection*

Ice core drilling started on August 23, 1995 from the bottom of a pilot borehole at a depth of 112 m. The drilling terminated at a depth of 2503.52 m on December 8, 1996. Figure 9 shows the drill site.

Figure 10 shows the drilling progress and daily coring depth with number of days from August 23, 1995. Daily drilling depth in 1996 increased with time by improving the methods of drilling and winch speed and reached the maximum of 20 m/day at a depth of around 1500 m but then it decreased with time due to increasing depth.

We used cutters with a rake angle of 30° and adjusted the shoe to a pitch of 2.0 to 2.2 mm for drilling above 1900 m. As the ice temperature rose to -29° at 1900 m depth, we changed the cutters to cutters with a rake angle of 40° and enlarged the pitch to 2.5 to 2.9 mm. For core catchers, we used the block type as they worked very well even for hard ice at the temperature of -55°C.

Drilling was carried out in two shifts with two operators on each shift. The typical hoisting and lowering speeds of the winch were 70–80 and 80–90 cm/min, respectively. The average time for cutting a 2 m core was 20 min. In July 1996, we started the use of the automatic drilling function. This function allows a winch to pay out a cable at adequate speed set around 10 cm/min when the cutter load lowered a threshold value by ice core cutting and stopped winch rotation when the cutter load exceeded the threshold value by paying out the cable. When cutters slipped, we changed the core cutting mode from automatic to manual to cut ice under cutting load higher than the threshold value. This automatic drilling function worked well.

The total numbers of core drilling and chip collection runs were 1370 and 836, respectively. The average length of core obtained per run was 1.75 m as shown in Table 2. We conducted chip collection at least one day per week.

Table 2. *Statistics of core drilling in 1995 and 1996.*

Item	1995	1996	Total
a. Number of coring run	315	1054	1369
b. Number of cancel run	9	58	67
c. Number of clip collection run	127	710	837
d. Number of reaming run	0	12	12
e. Number of service run	0	32	32
f. Number of coring days	81 days	210 days	291 days
g. Daily mean coring depth	6.18 m	9.00 m	8.21 m
h. Daily maximum coring depth	19.40 m	20.04 m	20.04 m
i. Mean coring depth per run	1.59 m	1.79 m	1.75 m
j. Coring length	501.43 m	1889.39 m	2390.82 m
k. Coring depth	614.02 m	2503.41 m	2503.41 m

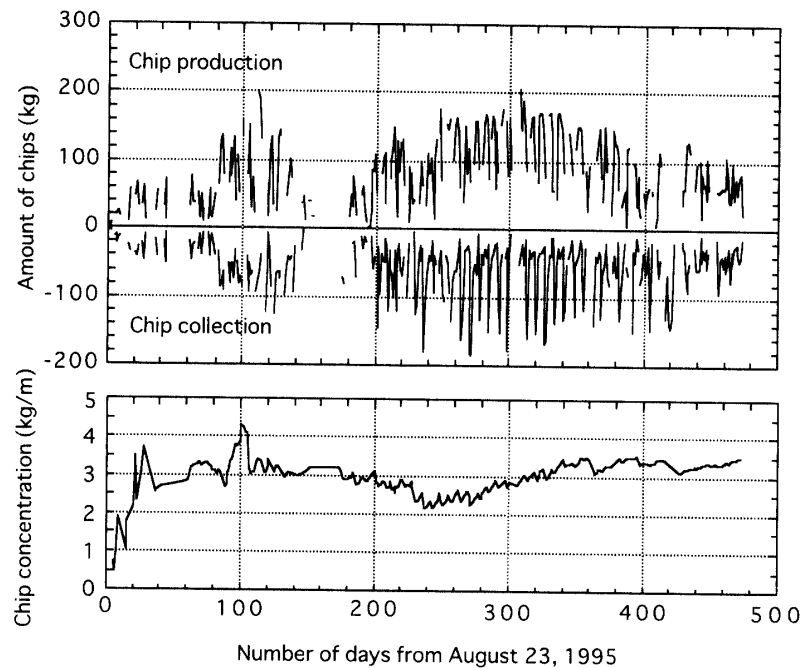

Fig. 11. Daily amounts of chips collected and produced (top) and change in chip concentration in borehole liquid (bottom). Chip amount is shown as its weight.

3.3. Chips and liquid temperature

We controlled the amount of chips in the borehole liquid by weighing the collected amount and by calculating the chip amount produced during ice core drilling. Figure 11 shows the change in daily amounts of production and collection together with chip concentration in liquid. Concentration of chips in borehole liquid was kept below 3 kg per 1 m of borehole liquid depth.

At depths above 2000 m, chip collection at each drilling run was insufficient because of outflow of chips from a chip chamber while hoisting the drill. With increasing liquid temperature from -55°C at shallow depths to -20°C at 2500 m (Fig. 12), the ice chip collection rate per run gradually improved with depth below 2000 m, where a larger depth of cut could be used due to decrease of ice hardness under warmer temperature.

3.4. Borehole inclination

The borehole was kept almost vertical, deviating not more than 0.5° until 1800 m, but increased gradually to 4.6° at 2250 m depth (Fig. 13). The probable reason for increasing inclination is due to stabilizers attached to the middle and the bottom of the outer jacket. They may have braked the drill movement during drilling and we needed to decrease cable tension to let the drill move down. This may have resulted in tilting the drill. After removing the stabilizers at 2250 m depth, we managed to improve borehole tilting to 3° at the depth of 2500 m.

3.5. Core quality

Core quality was excellent over the full length of the core, even in the brittle zone between 500 m and 840 m depth. The good core quality is thought to be mainly due to the small cutting rate, which was kept as small as 2 mm/rev because of ice hardness at -50

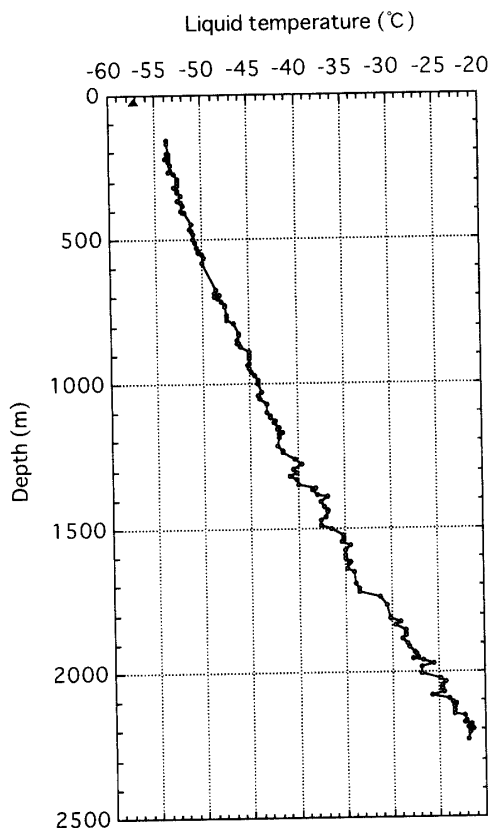

Fig. 12. Profile of borehole liquid temperature. Temperature was read just before the daily first run. Temperature at 10 m depth is the annual mean observed in 1995 (Azuma *et al.*, 1997).

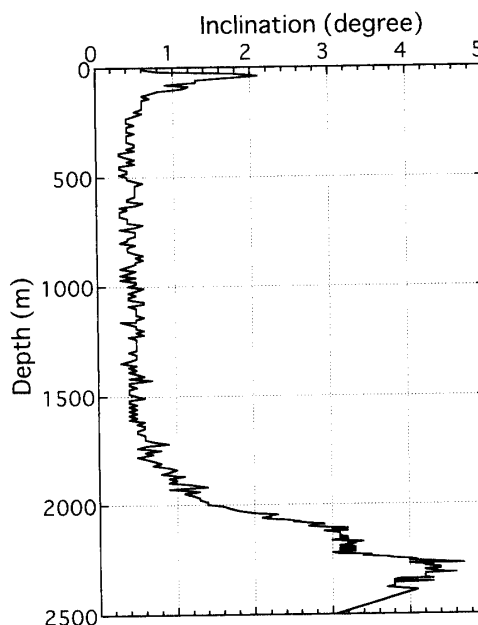

Fig. 13. Profile of borehole inclination.

to -60°C .

3.6. Ventilation

The problem in using n-butyl acetate is its high volatility and influence on human health (Fujita *et al.*, 1994). Gosink *et al.* (1991) pointed out that the maximum possible safe air concentration of n-butyl acetate in an unventilated area would be approximately 1300 ppm at -20°C . Though the air temperature of the drill trench was between -25 and -35°C , we could keep the concentration of n-butyl acetate in the drill trench below 20–30 ppm, which was monitored in the drill control room, by ventilating exhausting gases at the bottom of the tower trench, the drill site floor and near the winch.

4. Problems

The most serious problem was drill stuck at a depth of 2332 m on December 29, 1996 while reaming a reduced borehole diameter. The drill was stuck at the depth of the maximum borehole inclination of 4.5° . We had kept liquid level at 120–150 m depth and used out all amount of borehole liquid when reached to about 2000 m depth. Since then the liquid level had gradually lowered to 720 m as the borehole became deeper (Fig. 14).

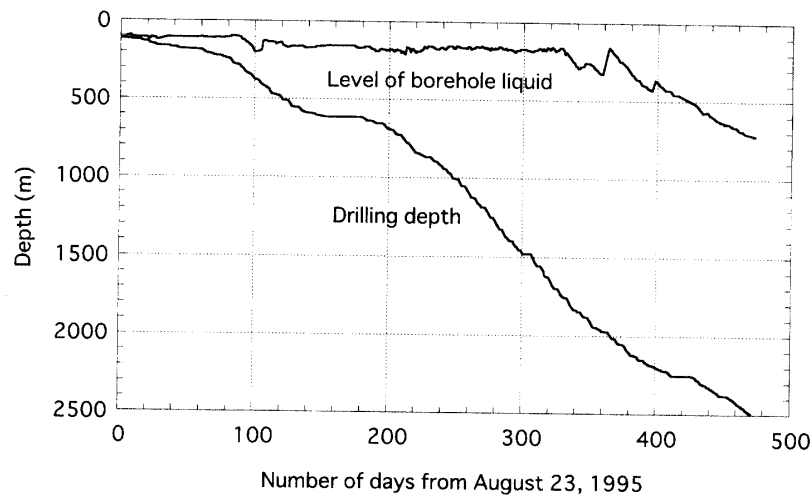

Fig. 14. Changes in borehole liquid level and borehole depth.

Due to the large imbalance between the hydrostatic pressures of the borehole liquid and the ice sheet, the borehole had started to close. We concentrated on the borehole reaming after reaching 2503 m, while waiting for the arrival of liquid transported by the next wintering team. Though we put n-butyl acetate in the borehole to raise the level to 100 m on January 6, 1997, and densifier in the borehole in 1998 and 1999, the drill has not been recovered yet.

Cable kink occurred once due to inadequate winch operation; that is, an operator paid out the cable faster than the speed of the drill freely falling in the liquid. The kink could not be mended and eventually was cut. Three conductors among seven were broken at around the liquid level. This is considered to be due to the larger coefficient of expansion (contraction) of Teflon, the coating of the conductor, than that of armored steel wire, or due to different structures between a straight conductor and twisted armored steel wire. As we had warmed the winch cable prior to this incident, the drill cable should have contracted in the liquid as low as -60°C .

Various parts dropped to the borehole bottom. The largest one was a core barrel 2.2 m long. It happened because a driller didn't screw the barrel to the coupler. The barrel was recovered by coupling the coupler to the top of a barrel standing vertically with core being uncut at the bottom. Many screws dropped but were collected with a magnet.

5. Conclusions

The drill worked passably well over the whole depth. The largest defect was outflow of chips from the chip chamber while hoisting the drill. This forced a large number of chip collections, as many as 837 times. Stabilizers on the outer jacket tube prevented smooth movement of the drill during drilling and caused borehole tilting. Core quality was perfect over the full length of the core, even in the brittle zone between 500 and 840 m depth. This is probably due to the small cutting rate because of the ice hardness at a temperature of -50 to -60°C .

Acknowledgments

We would like to express our sincere gratitude to the JARE and the project members for their support and cooperation given during the Dome-Fuji Project.

References

- Ageta, Y., Kamiyama, K., Okuhira, F. and Fujii, Y. (1989): Geomorphological and glaciological aspects around the highest dome in Queen Maud Land, East Antarctica. *Proc. NIPR Symp. Polar Meteorol. Glaciol.*, **2**, 88–96.
- Azuma, N., Kameda, T., Nakayama, Y., Tanaka, Y., Yoshimi, H., Furukawa, T. and Ageta, Y. (1997): Glaciological data collected by the 36th Japanese Antarctic Research Expedition during 1995–1996. *JARE Data Rep.*, **233** (*Glaciology* 26), 83 p.
- Dome-F Deep Ice Coring Group (1999): Deep ice core drilling at Dome Fuji and glaciological study in east Queen Maud Land, Antarctica. *Ann. Glaciol.*, **27**, 333–337.
- Fujii, Y., Motoyama, H., Narita, H., Shimbori, K., Azuma, N., Tanaka, Y., Miyahara, M., Takahashi, A., Watanabe, O. (1990): Development of the JARE deep ice coring system. *Nankyoku Shiryô (Antarct. Rec.)*, **34**, 303–345. (in Japanese with English abstract).
- Fujita, S., Yamada, T., Naruse, R., Mae, S., Azuma, N. and Fujii, Y. (1994): Drilling fluid for Dome F Project in Antarctica. *Mem. Natl Inst. Polar Res., Spec. Issue*, **49**, 347–357.
- Gosink, T.A., Kelley, J.J., Koci, B.R., Burton, T.W. and Tumeo, M.A. (1991): Butyl acetate, an alternative drilling fluid for deep ice-coring projects. *J. Glaciol.*, **37**, 170–176.
- Johnsen, J.S., Gundestrup, N.S., Hansen, S.B., Schwander, J. and Ruffli, H. (1994): The new improved version of the ISTUK ice core drill. *Mem. Natl Inst. Polar Res., Spec. Issue*, **49**, 9–23.
- Morgan, V., Wehrle, E., Fleming, A., Richardson, M., Elcheikh, A. and Brand, R. (1994): Technical aspects of deep ice drilling on Low Dome. *Mem. Natl Inst. Polar Res., Spec. Issue*, **49**, 78–86.
- Motoyama, H., Enomoto, H., Miyahara, M. and Watanabe, O. (1995): Shallow ice coring and borehole casing at Dome Fuji Station, east Antarctica. *Nankyoku Shiryô (Antarct. Rec.)*, **39**, 189–197.
- Narita, H., Fujii, Y., Nakayama, Y., Kawada, K. and Takahashi, A. (1994): Thermal ice core drilling to 700 m depth at Mizuho Station, east Antarctica. *Mem. Natl Inst. Polar Res., Spec. Issue*, **49**, 172–183.
- Takahashi, S. and Azuma, N. (1994): Plan of Dome-F station for deep ice-coring by the Japanese Antarctic Research Expedition (JARE). *Mem. Natl Inst. Polar Res., Spec. Issue*, **49**, 386–395.
- Tanaka, Y., Takahashi, A., Fujii, Y., Narita, H., Shinbori, K., Azuma, N. and Watanabe, O. (1994): Development of a JARE ice core drill system. *Mem. Natl Inst. Polar Res., Spec. Issue*, **49**, 113–123.
- Wumkes, M.A. (1994): Development of the U.S. deep coring ice drill. *Mem. Natl Inst. Polar Res., Spec. Issue*, **49**, 41–51.

(Received July 23, 2001; Revised manuscript accepted September 14, 2001)