

Ice core drilling on Southern Patagonia Icefield — Development of a new portable drill and the field expedition in 1999 —

Shiro Kohshima¹, Takayuki Shiraiwa², Maria Angelica Godoi³,
Keiji Kubota⁴, Nozomu Takeuchi¹ and Kunio Shinbori²

¹*Faculty of Bioscience and Biotechnology, c/o Faculty of Science, Tokyo Institute of Technology, 12-1, Ohokayama, 2-chome, Meguro-ku, Tokyo 152-8551*

²*Institute of Low Temperature Science, Hokkaido University, Kita-19, Nishi-8, Kita-ku, Sapporo 060-0819*

³*Dirección de Programas Antárticos, Instituto de la Patagonia, Universidad de Magallanes, Casilla 113-D, Punta Arenas, Chile*

⁴*Graduate School of Earth Environmental Science, Hokkaido University, Kita-10, Nishi-5, Kita-ku, Sapporo 060-0810*

Abstract: A 45.97 m-deep drilling operation was carried out during November/December 1999 on the accumulation area of Tyndall glacier (50°59'05"S, 73°31'12"W, 1756 m a.s.l.) at the southern end of the Southern Patagonia Icefield. A portable electromechanical drilling system was developed for ice-coring on temperate glaciers which often have aquifers near the pore-close off depths. The firn-core obtained was subjected to visual stratigraphic observations and bulk-density measurements. Preliminary results suggest an extremely high accumulation rate (about 12–14 m a⁻¹ w.e.) at the drilling site. The drilling operation was strenuous because of the continuous strong wind and enormous snowfall which forced the members to survive for nearly three weeks in a snow cave before evacuation.

1. Introduction

The mass balance of mountain glaciers is one of the key factors that will effect future sea level change (IPCC, 1996). Despite widespread glacier-monitoring (IAHS(ICSU)/UNEP/UNESCO, 1989), the mass balance on the Patagonian Icefield, one of the largest ice masses outside the polar regions, is still not known with sufficient accuracy. Information is lacking especially in the accumulation area, where ground monitoring of the mass balance is very difficult because of the year-round bad weather condition. Therefore, to estimate the mass balance in this area, we should monitor with radar satellites or reconstruct the mass balance over time by ice core analyses.

Little has been done on the Patagonian Icefield in respect of ice cores, however. Yamada (1987) reported the first ice-core drilling in the accumulation area of San Rafael Glacier (1296 m a.s.l.), in the Northern Patagonia Icefield (NPI). He estimated an annual net accumulation of 3.45 m w.e. for the year 1984 from the profile of oxygen stable isotope and firn density of the 37.6 m-long core. Matsuoka and Naruse (1999) then recovered a

14.5 m-deep firn core, in November and December 1996, in the accumulation area of Glacier Nef (1500 m a.s.l.), NPI. They estimated a net accumulation of 2.2 m w.e. for the calendar year 1996 from the stable oxygen isotope profile and the mass balance calculation using climatic data of nearby meteorological stations. Neither Yamada (1987) nor Matsuoka and Naruse (1999) could obtain direct evidence of the net accumulation rate from the ice cores, because intensive melting at the boring sites smoothed out the isotopic signals along the ice cores. Aristarain and Delmas (1993) analyzed δD and major ions of a 13.17 m-long firn core drilled on the accumulation area of glacier Perito Moreno (2680 m a.s.l.) on the Southern Patagonia Icefield (SPI) and reconstructed a mean annual accumulation of 1.2 m w.e. for the years between the summer of 1980/81 and 1985/86. The authors cautioned that the unexpectedly low net-accumulation rate might be reduced either by wind-erosion or runoff of melt water. This time, we drilled at altitudes where less wind effect and less melting are expected, and tried to use snow algae as boundary markers of annual accumulations. Since snow algae grow in the surface snow during the thawing period, layers in ice-cores with considerable snow algae have been reported to be used as good markers of annual layers in a Himalayan ice-core (Yoshimura *et al.*, 2000).

This paper reports on the ice-core drilling to a depth of 45.97 m, carried out by a Japanese-Chilean joint expedition, on the accumulation area of Tyndall glacier (SPI) in November/December 1999. First, we describe a newly developed portable drill system specially designed for a temperature mountain glacier. We then describe the drilling operation in severe weather conditions. We finally show preliminary results on the physical properties of the ice core and roughly estimate the net accumulation rates at the drilling site of Tyndall glacier for the last two years.

2. Drilling site

The drilling site is located at the divide between the Tyndall glacier to the east and the Amaria glacier to the west in the SPI (Fig. 1). The drilling site is approximately 500 m east of the divide on the accumulation area of Tyndall glacier (50°59'05"S, 73°31'12"W, 1756 m a.s.l.). Tyndall glacier flows southward in the southernmost part of the SPI, covering a total area of about 331 km², stretching for 32 km and calving into a proglacial lake (Aniya *et al.*, 1996).

The surface of the glacier at the drilling site is inclined by 1° to the east. There are nunataks approximately 2 km south of the drilling site. The thickness of the glacier at the drilling site is unknown, however, preliminary radio-echo soundings suggest that the thickness might be more than 600 m (A. Rivera and G. Cassasa, pers. commun.).

The snow surface at the drilling site was almost flat at the beginning of the drilling, but it changed to an undulating surface through the drilling operation, mainly due to the continuous drifting of snow.

3. Development of the portable ice coring drill

The lightweight waterproof electromechanical drill was manufactured in the workshop of the Institute of Low Temperature Science, Hokkaido University by one of the authors (K. Shinbori). The drill is specially designed for high mountain temperate

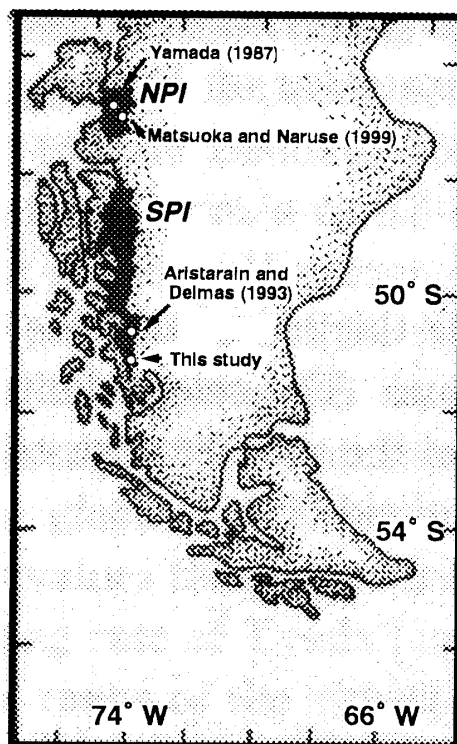

Fig. 1. Location of the drilling site. Previous drilling sites are also shown.

glaciers with water aquifers at the firn-ice transition zone. The following five requirements should have been fulfilled; 1) the drill should be usable for at least 100 m-deep drilling; 2) the system weight including winch and mast should be less than 100 kg; 3) an ice core of 50 cm in length and 75 mm in diameter can be recovered at one time; 4) the electronics section of the drill is water tight at pressure up to at least 1 MPa; and 5) borehole logging is possible through steel armored cable (Electro-Mechanical Cables of the ROCHESTER corporation).

The drill system was composed mainly of the following 5 sections: slip ring, anti-torque mechanism, drill motor, chip chamber, and core barrel (Figs. 2 and 3). A newly designed pantographic-type of anti-torque mechanism was prepared so as to reduce the slip which was known to be inherent to the leaf-spring type. This system presented some problems during the work. Two kinds of core barrel were prepared: the dry and liquid-filled types, respectively. The two types can be adapted to the same motor so that the total weight can be reduced. Some characteristics of the drill, the mast and the winch systems used are shown in Tables 1 and 2.

The drill basically worked well. A firn core was obtained down to a total drilling depth of 45.97 m. It comprises a 40.65 m core recovered in about 5 days, using the drill mentioned above, and a shallow core 5.47 m long obtained using a hand auger. The drill recovered good quality cores in the shallower part. The diameter and the length of the core obtained at each drilling run were 74 mm and 50 cm on average (Fig. 4). The pantographic anti-torque mechanism caused problems when we drilled through horizons composed of different densities, *i.e.* melt-frozen layers in firn and water-soaked layers. At

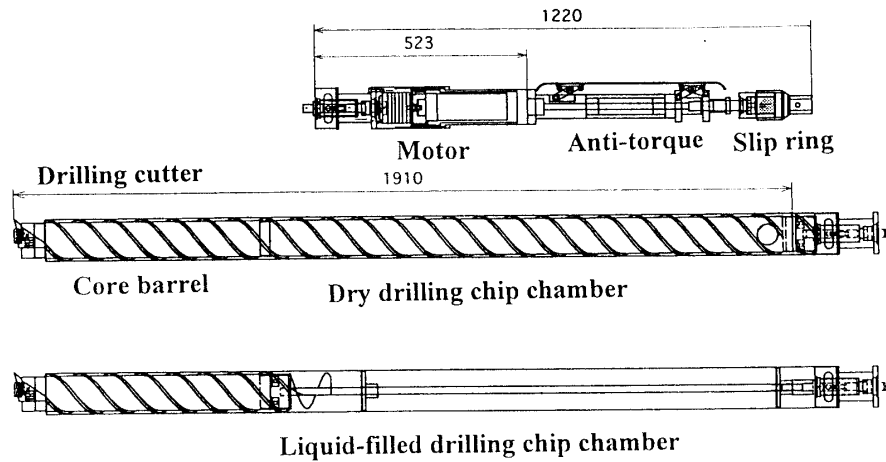

Fig. 2. Schematic drawings of the newly developed electromechanical drill. Size is given in mm.

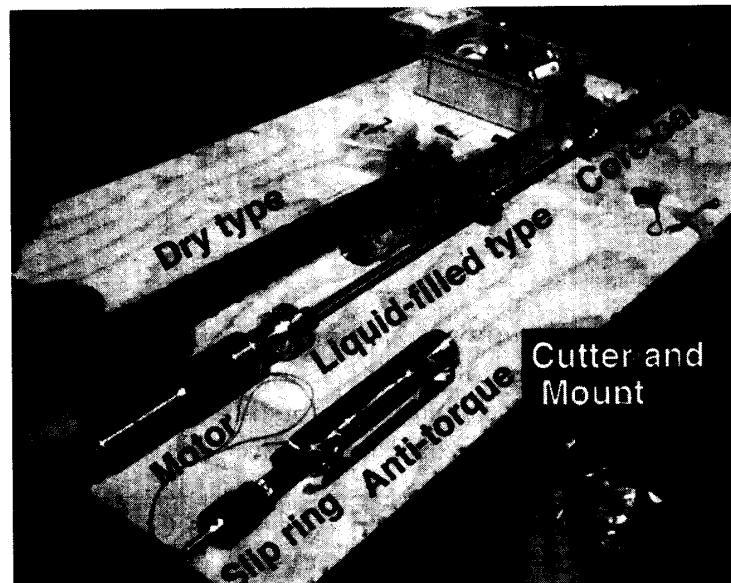

Fig. 3. Photograph of the sections of the drill system.

Table 1. Specifications of the newly developed electromechanical drill.

Type	Electromechanical drill
Core diameter	74 mm
Core length	Firm: 80 cm, Ice: 65 cm
Drilling speed	20–40 cm·min ⁻¹ : variable by replacing cutters and heels
Size of drill	110 mm × 3130 mm; 38 kg
Type of anti-torque	Newly designed pantographic type
Motor	AC 200–220 V (50 Hz), 360 W
Barrel specification	Dry chip chamber type Liquid-filled chip chamber type
Controlling system	Variable by voltage controller
Remarks	Water proof

Table 2. Specifications of the mast and the winch systems for the drill.

Type	Tilting tower type
Size of mast	200 mm × 2300 mm; 8 kg
Size of winch	500 mm × 500 mm × 400 mm; 35 kg
Winch speed	15 m·min ⁻¹ in average
Maximum load	80 kg
Motor	DC 100 V, 300 W
Controlling system	Variable by voltage controller
Cable	Armored cable: diameter 5.7 mm; length 120 m; drilling depth 100 m; conductor 4 lines

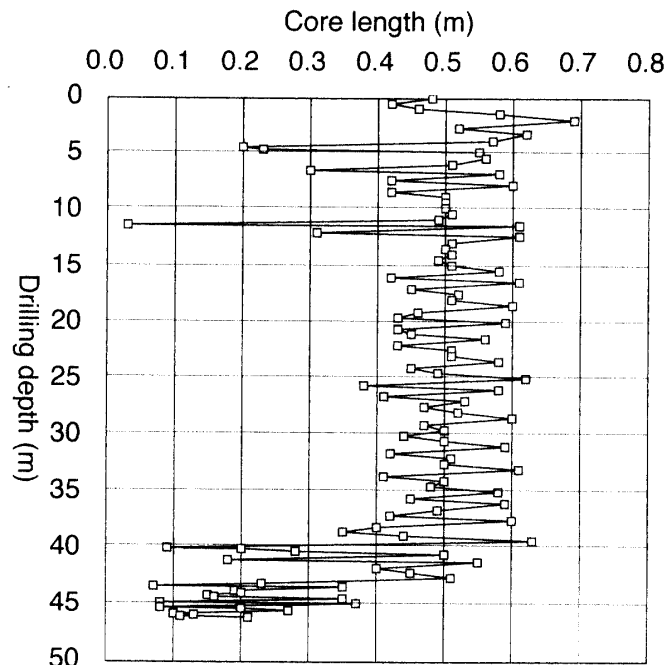

Fig. 4. Lengths of the cores from each drilling run.

these horizons, the anti-torque mechanism slipped many times, and drilling was not always easy. Another major problem was the size of the drill. We made the drill as light as possible by reducing its diameter. This made it impossible to install the motor section inside a cylinder where the anti-torque system was attached. As a result, the total length of the drill became as long as 3.13 m. This length was extremely disadvantageous in the drilling operation in the logistically difficult glacier. The length forced us to make a relatively larger snow cave to operate the ice-coring, and this was not easy work in the bad weather described below.

4. Logistics and weather conditions

We went on standby for helicopter operation from November 12, 1999 at the

headquarters of Torres del Paine National Park, approximately 40 km east of the drilling site. After waiting for good weather for 2 weeks, three members and equipment were transported by a helicopter to the drilling site, on 27 November. The remaining three members and the equipment were then transported there on 29 November, after waiting one day for additional good flight weather.

A trench was dug to allow the drilling operation to be carried out under any weather condition, following Yamada *et al.* (1987). Enough room was allowed for core drilling, processing and storage of the samples (Fig. 5). Excavation of the drilling trench and installation of the drilling system took about 5 days.

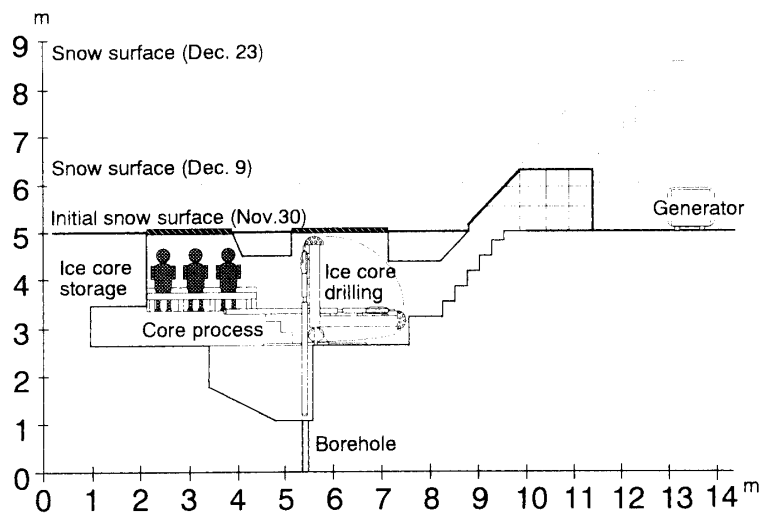

Fig. 5. Cross profile of the drilling trench. The snow surface increased from the levels of 5 m to 8.5 m relative to a reference level in the borehole from November 30 to December 23.

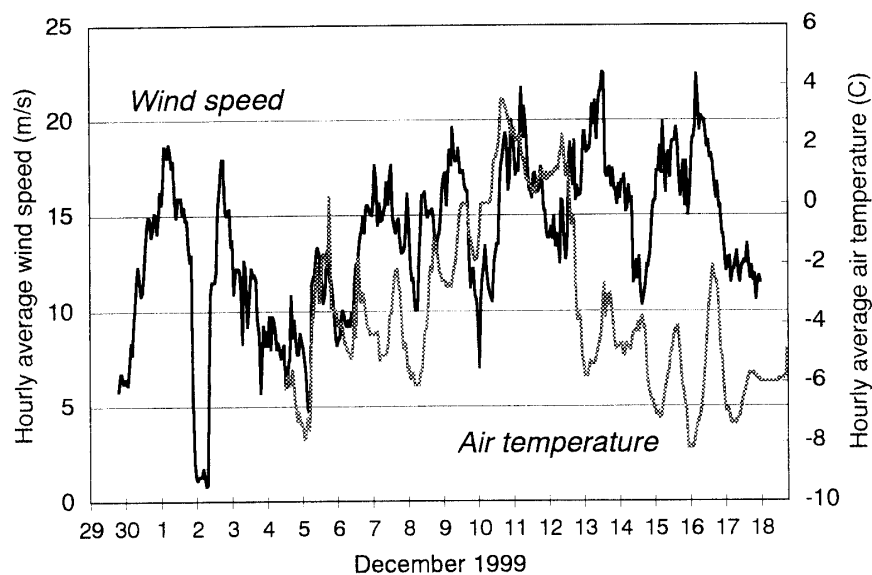

Fig. 6. Hourly average wind speed (thick line) and air temperature (thin line) at the drilling site during the operation.

Although the drilling operation was completed by December 9, the expedition extended beyond the planned date since weather conditions did not allow the helicopter to perform the evacuation flight. On December 23, with terrestrial support from the lower part of the glacier, people and minimum equipment were evacuated by a snowmobile equipped with four sledges to a lower altitude (1100 m a.s.l.), from where conditions allowed an evacuation by helicopter. Most of the equipment carried to the plateau remained virtually buried under several meters of snow.

During the field campaign, no more than four days out of 25 presented good visibility. The camp was constantly threatened with blizzards and heavy snow, and clearing of the snow from the tents was a hard daily task. All the tents were finally collapsed by December 17; the members were forced to stay in the drilling trench thereafter. The level of the surface was continuously increased, as can be seen in Fig. 5, from November 30 to December 23, suggesting an extremely high accumulation rate. Hourly average wind was always strong (mean speed: 13.6 m s^{-1}) and made camping extremely difficult (Fig. 6). Hourly average air temperature was always near the freezing point, and the relatively higher air temperature was problem for storage of the ice core.

5. Physical properties of the ice core

The core recovered was cut into 25 cm sections. After stratigraphic observations and bulk density measurements the core was vertically cut into 3 pieces (one half, and two fourths). The half was packed in sealed plastic bags and kept untouched. The external surface of the two other pieces was removed using a pre-cleaned ceramic knife and the samples were packed in separate sealed plastic bags. Unfortunately, as weather conditions only allowed for an emergency evacuation procedure, only one set of samples (one fourth of the core) could be saved for laboratory analyses. Those samples were kept frozen until their arrival at the Institute of Low Temperature Science in Japan, where they are being analyzed. It was planned to measure the borehole temperature after the drilling; however this was not possible due to the inflow of melt water inside the hole from the borehole mouth.

5.1. Stratigraphy

The core recovered consists of dry firn with ice layers of various thickness (1–50 mm) until water soaked firn started to be obtained at a depth of 42.55 m. Distribution of the ice layers in the core was not uniform. Some sections of the core (5 m, 17–24 m, and 38–39 m in depth) contained many thick ice layers, while other sections contained very few ice layers.

5.2. Bulk density

Bulk density was calculated from the weight and volume of every core section obtained. As can be seen in the profile (Fig. 7), density presents a nearly linear and slow increase with depth, until about 42 m when water soaked firn started to be obtained. Then it rises quickly, reaching values close to the density of ice. Pure ice was not reached at a depth of 45.97 m where the drilling operation stopped.

Thus, the firn/ice transition zone for this glacier started at a depth of 42 m, and the

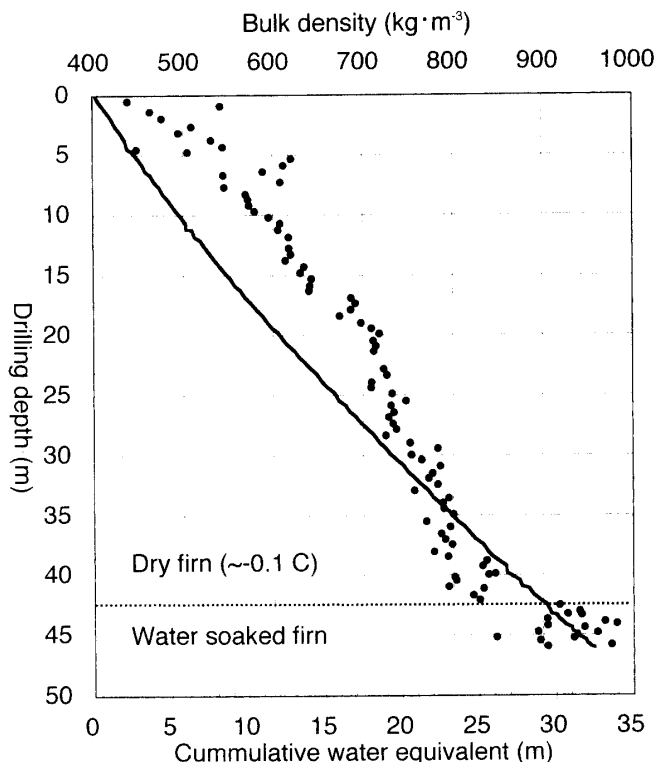

Fig. 7. Profiles of bulk density (dots) and cumulative water equivalent (solid curve) of the firn-core.

ice boundary was encountered soon below 46 m. Yamada (1987) found this transition zone between the depths of 19.7 and 26.7 m on the accumulation area of San Rafael glacier (NPI), 1296 m a.s.l. On Tyndall glacier this transition zone started much deeper, probably due to a higher accumulation rate. The solid line in Fig. 7 represents the cumulative water equivalent profile.

5.3. Melt feature percentage

Melt feature percentage (Fig. 8) was calculated in terms of water equivalent for every 1 m of core. Melt feature percentage is an index defined by aerial fraction between ice and firn layers within a unit area along the firn cores, and it has been used for summer temperature proxy record (*e.g.* Koerner, 1977). Several ice layers of variable thickness were found along the firn core. Their interpretation as melt-freeze events occurring at the surface is not straightforward for temperate glaciers. Ice layers might be the result of percolation of liquid precipitation as well as percolation of surface melting during summer or wintertime, finally re-freezing at depth within a layer of a previous season. However, assuming that those effects are, in this case, not enough to mask the signal, we may consider that the middle of the summers 1999/2000, 1998/99, and 1997/98 correspond to depths of 0 m, 20 m, and 39 m, respectively. Thus, using the graph of cumulative water equivalent (Fig. 7), we can obtain preliminary estimations of 12 m w.e. (1998/99–1999/2000) and 14 m w.e. (1997/98–1998/99) for the annual accumulations during these years. It is expected that in this case melt-water percolation does not destroy the seasonal patterns in the

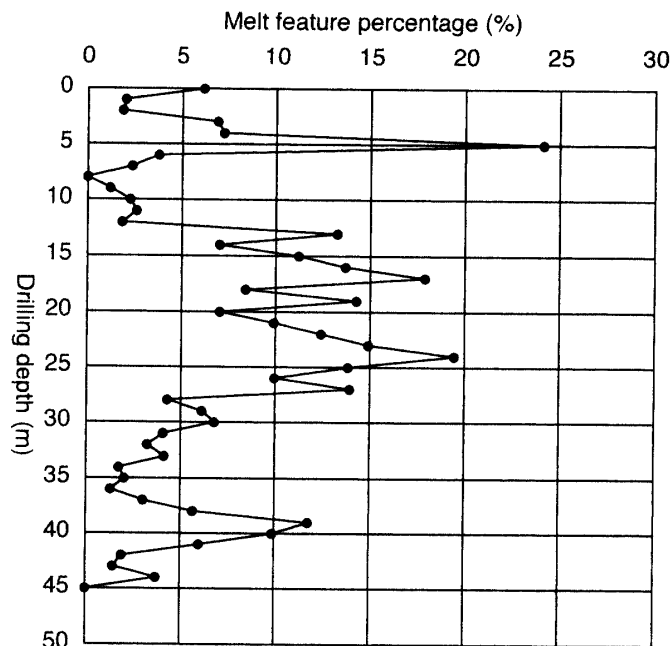

Fig. 8. Melt feature percentage in the 45.97 m-long firn core.

isotopic profiles, so that this figure can be checked when the core analyses are completed.

6. Conclusions

The drilling in the accumulation area of Tyndall Glacier (1756 m a.s.l.) showed near-temperate firn down to a depth of 45.97 m. Water-saturated firn was found at approximately 42 m, marking the beginning of the firn/ice transition zone. Thus, the firn/ice boundary is below 46 m.

Preliminary results suggest a net accumulation rate of about 12–14 m a⁻¹ w.e., for the years between the summers 1999/00, 1998/99, and 1997/98. This is an extremely high value when compared to the results of Aristarain and Delmas (1993), Yamada (1987), and Matsuoka and Naruse (1999). However, it is in good agreement with the conditions of snow precipitation experienced during the field campaign and more significantly with hydrological estimate of total precipitation over the Patagonia Icefields by annual amount of 6 m in water (Escobar *et al.*, 1992). Our reconstructed net accumulation rate has to be checked with subsequent core analyses currently underway.

Weather conditions experienced in the field proved that logistics are critical when planning a drilling operation on the SPI.

Acknowledgments

The authors would like to thank Marcelo Arevalo and Jorge Quinteros for their valuable support during the field campaign. The evacuation operation headed by Drs. Gino Cassasa and Andreas Rivera is highly appreciated. Technical support in developing the drilling system given by Workshop staff members at the Institute of Low Temperature

Science is also appreciated. This field expedition was funded by grants-in-aids for Basic Research A (No. 10041105: Principal Investigator: M. Aniya) and Basic Research C (No. 11640422: Principal Investigator: R. Naruse) both from the Ministry of Education, Science, Sports and Culture of Japan, and from the Fondo Nacional de Ciencia y Tecnologia (FONDECYT 1980293) of Chile. Development of the drilling system was financially supported by the Leadership Fund from the Institute of Low Temperature Science.

References

- Aniya, M., Sato, H., Naruse, R., Skvarca, P. and Casassa, G. (1996): The use of satellite and airborne imagery to inventory outlet glaciers of the Southern Patagonia Icefield, South America. *Photogramm. Eng. Remote Sensing*, **62**, 1361–1369.
- Aristarain, A.J. and Delmas, R.J. (1993): Firn-core study from the southern Patagonia ice cap, South America. *J. Glaciol.*, **39**, 249–254.
- Escobar, F., Vidal, F. and Garin, C. (1992): Water balance in the Patagonia Icefield. *Glaciological Researches in Patagonia, 1990*, ed. by R. Naruse and M. Aniya. Sapporo, Inst. Low. Temp. Sci., Hokkaido Univ., 109–119.
- IAHS(ICSI)/UNEP/UNESCO (1989): *World Glacier Inventory-Status 1988*, ed. by W. Haeberli *et al.* Nairobi, UNEP.
- IPCC (1996): *Climate Change 1995, The Science of Climate Change*, ed. by Houghton *et al.* Cambridge University Press, 572 p.
- Koerner, R.M. (1977): Devon Island ice cap: core stratigraphy and paleoclimate. *Science*, **196**, 15–18.
- Matsuoka, K. and Naruse, R. (1999): Mass balance features derived from a firn core at Hielo Patagonico Norte, South America. *Arc. Antarct. Alp. Res.*, **31**, 333–340.
- Yamada, T. (1987): Glaciological characteristics revealed by 37.6-m deep core drilled at the accumulation area of San Rafael Glacier, the Northern Patagonia Icefield. *Bull. Glacier Res.*, **4**, 59–67.
- Yamada, T., Kondo, H. and Fukuzawa, T. (1987): Ice core drilling operations in the Northern Patagonia Icefield. *Bull. Glacier Res.*, **4**, 151–155.
- Yoshimura, Y., Kohshima, S., Takeuchi, N., Y., Seko and Fujita, K. (2000): Himalayan ice core dating with snow algae. *J. Glaciol.*, **46**, 153, 335–340.

(Received December 27, 2000; Revised manuscript accepted April 9, 2001)