

## *Radio Echo Sounding of Antarctic Ice*

*Takeo YOSHINO\**, and *Tsuneo ETO\*\**

### **1. Introduction**

The radio echo sounding system for the ice thickness measurement was operated on the roundtrip trans-continental traverse between Syowa Station and the South Pole in 1968-69 by the Japanese Antarctic Research Expedition (JARE) 1967-69, headed by M. MURAYAMA. The original report of the radio echo sounding phenomena based on the gross error of the radio altimeter was published by the U. S. Army Signal Corps Antarctic Research headed by A.H. WAITE (1961), at the IGY Symposium, Wellington, New Zealand, February 1958.

The first systematic research on the radio wave rays which propagate through the Antarctic ice sheet was started in 1959 by T. YOSHINO (1961, 1965, 1967) who was a member of the Japanese Antarctic Research Expedition 1958-60. After this research, the British radio sounding team headed by S. EVANS (1964, 1965) of the Scott Polar Research Institute attacked the Greenland ice cap from 1964.

The present report describes the equipment and results of the radio echo sounding measurement by the JARE South Pole Traverse 1968-69.

### **2. Group Velocity of Radio Waves Propagating through Antarctic Ice Sheet**

The group velocity  $V_g$  (m/s) of the radio waves which propagate through a homogeneous polycrystalline ice sheet is given by

$$V_g = \frac{c}{\sqrt{\varepsilon^*}} \quad (1)$$

where  $c$  is the light velocity in vacuum ( $3 \times 10^8$  m/s), and  $\varepsilon^*$  is the specific inductive capacity of polycrystalline ice.

Determination of the dielectric constant of the Antarctic ice sheet has been attempted by the Japanese, U.S.A., U.S.S.R., and British expedition teams since 1958. The values obtained by the Japanese team are used in this paper. The vertical variation of the dielectric constant from the surface to the bottom is shown in Fig. 1 (YOSHINO, 1967).

The annual average surface temperature and snow density of the Antarctic ice sheet are approximately  $-30^\circ\text{C}$  and 0.2 to 0.4, respectively. The density

\* University of Electro-Communications, Chofu, Tokyo.

\*\* Sakura-jima Volcanological Observatory, Kyoto University, Sakura-jima, Kagoshima. Member of the JARE South Pole Traverse 1968-69.

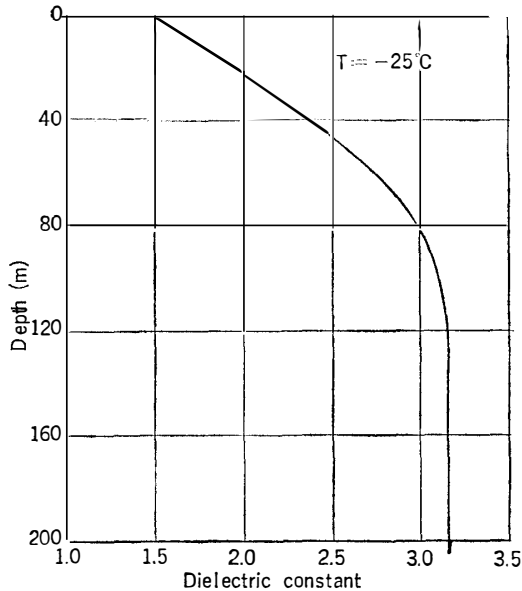

Fig. 1. The vertical profile of dielectric constant.

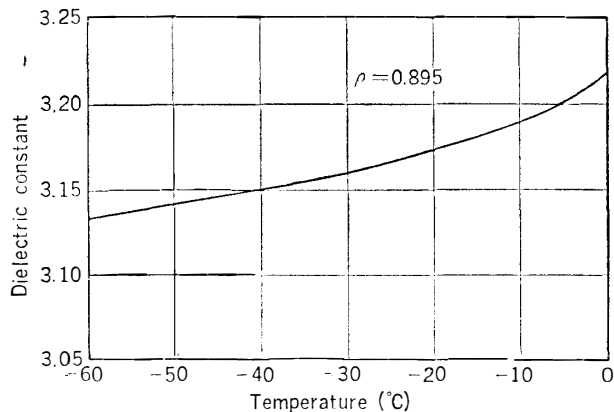

Fig. 2. Relation between dielectric constant and temperature.

increases with the depth from 0.3 to 0.89, until a depth of about 120 m is reached. The dielectric constant is about 3.17 at  $-30^{\circ}\text{C}$  and 30 MHz, the value being rather insensitive to variations in temperature (Fig. 2). In reference to Figs. 1 and 2, the group velocity values for  $0^{\circ}\text{C}$  and  $30^{\circ}\text{C}$  have been assigned to  $167\text{ m}/\mu\text{s}$  and  $168.5\text{ m}/\mu\text{s}$  respectively.

It should be noted, however, that the dielectric loss tangent depends remarkably on temperature. This makes the loss values for radio waves propagating through the ice sheet rather unreliable. Fig. 3 (LIBOUTRY, 1966) gives a typical vertical temperature profile in the Antarctic ice sheet. The temperature just below the surface is close to the annual average air temperature. The temperature rises with the depth gradually, and reaches the melting point at about 1600–1800 m depth.

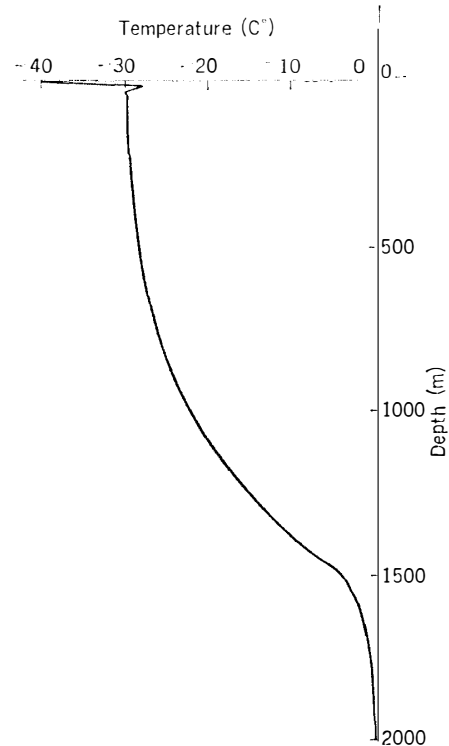

Fig. 3. A typical vertical temperature profile of Antarctic ice sheet.

### 3. The JARE Ice Echo Sounder

The first model of the ice echo sounder was developed in 1964 in the University of Electro-Communications, Tokyo, Japan. The second model, built in the same University, was used in the JARE South Pole Traverse 1968-69. Table 1 gives the specification of this equipment.

*Table 1. Specification of the ice echo sounder.*

a) Transmitter	
Type of modulation	$P_0$
Peak output power	1.2 kW
Frequency	30.0 MHz
Pulse-width	0.3 $\mu$ s (half power)
Pulse-rise time	0.1 $\mu$ s
Pulse-decay time	0.4 $\mu$ s
Frequency stability	less than $10^{-5}$
External dimensions	75 $\times$ 30 $\times$ 27 cm
Weight	10 kg
b) Receiver	
Sensitivity	10 $\mu$ V on S/N 10 dB
Noise figure	5.2 dB
RF band width	12.2 MHz
Video band width	4.1 MHz
RF amp. gain	61.2 dB
Video amp. gain	50.1 dB at 2 MHz
External dimensions (including indicator)	75 $\times$ 30 $\times$ 27 cm
Weight	18 kg
c) Antenna	
Transmitter and receiver antenna—Half-wave dipole with a reflector element.	
Feeder—8D-2V (50 ohms), similar to RG-8A/U, 10 m, for both transmitter and receiver.	
d) Power source	DC 12 and 24 V Peak 2.2 kW Average 300 W
e) Manufacture	
Original design	Univ. of Electro-Communications
Manufacturer	Kokusai Electronics Corporations Inc.

#### 3.1. Construction

Fig. 4 is the block diagram of the ice echo sounder. It consist of a receiver-indicator, a transmitter, a receiving antenna and a transmitting antenna. The power is supplied from a 12 V battery, which is charged by a generator driven by the snow vehicle engine during the traverse.

#### 3.2. Circuit description

**Transmitter:** The crystal oscillator is a three times-overtone circuit using a 12BY7A. The output 30 MHz RF voltage is supplied to the grid of a pulse gate

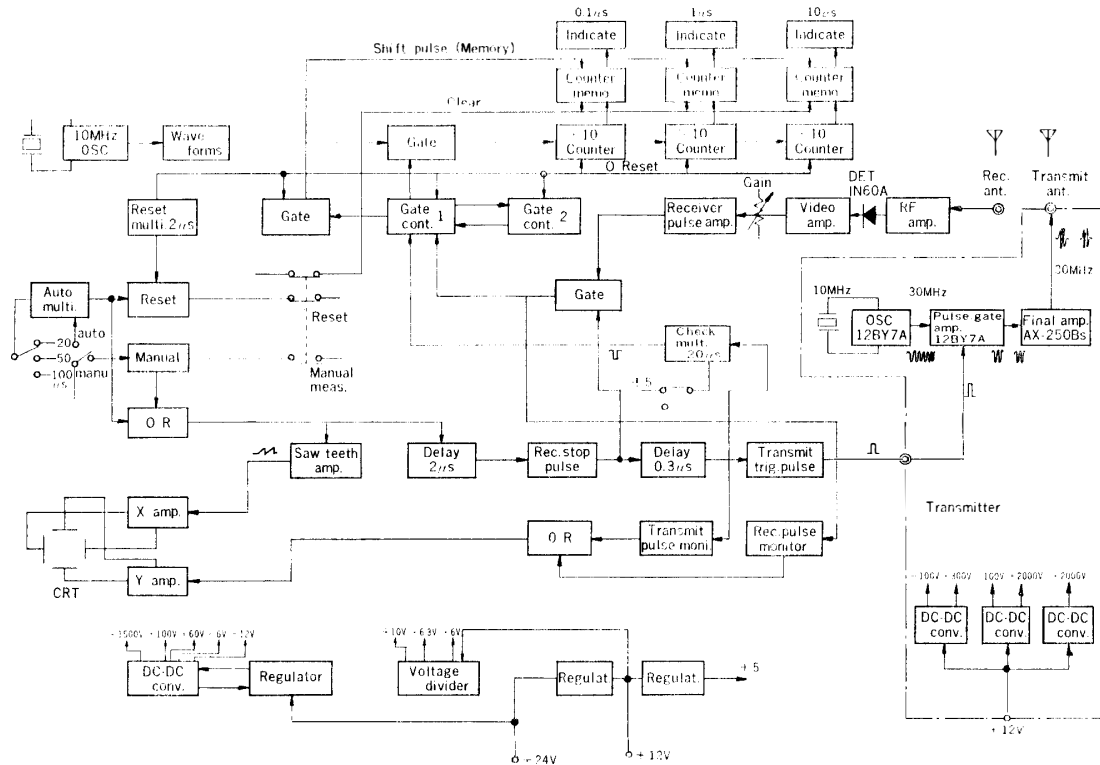

Fig. 4. A block diagram of the ice echo sounder.

amplifier also using 12BY7A. The DC grid bias voltage of this pulse gate amplifier is always kept at  $-40\text{ V}$  in order to secure the cut-off of the plate current. To open the gate of this stage, a gate pulse voltage ( $+20\text{ V}$ ,  $0.3\ \mu\text{s}$ ) is required which is supplied from the pulse generator section.

The final stage, which consists of a pair of 4X-250B's connected in parallel, functions as a class C amplifier. The tubes are always kept at "cut-off", except during the period the RF pulsed signal is being driven from a gate amplifier of younger stage. This final stage does not require forced cooling for the average plate input power is small.

**Receiver:** The RF amplifier is a three-stage IC (Type RCA-3004) straight staggered amplifier, whose band width is extremely broad and has very low noise figure. After the detector using a IN60A, a 50 dB IC (Type RCA-3016) video amplifier is used, whose band width is DC to 4 MHz. The antenna input circuit has two diodes to impede the transmitter leakage.

**Indicator:** The indicator has two selectable systems. One is a digital indication system in which a time counter circuit is employed, and the other is an A-scope indication system using a 5-inch CRT.

**Antenna:** The transmitter and receiver antennas are unfolded directly on the snow surface as shown in Fig. 5.

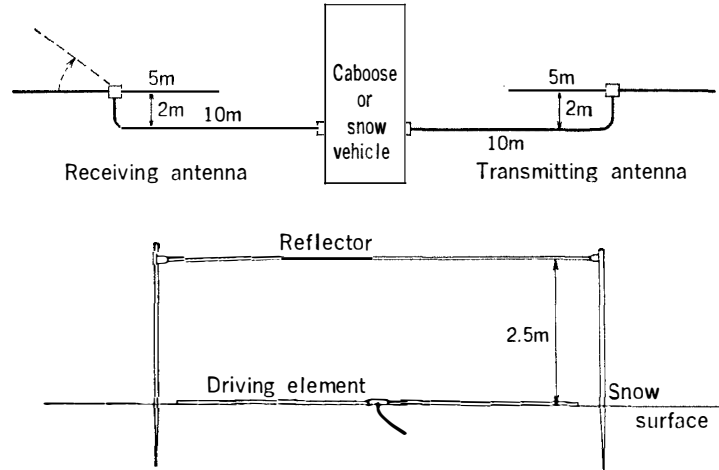

Fig. 5. The antenna system of the ice echo sounder.

Main pulse generator and digital indicator circuit: This stage uses 32 IC's, 56 transistors, and 51 diodes. The detail of this stage is illustrated in Fig. 4 (block diagram).

A teflon-coated heating wire is used as a pre-heater.

#### 4. Results of Measurement

The JARE South Pole Traverse 1968-69 made ice thickness measurement at

Table 2. Data of the ice echo sounder measurements.

Date 1968	September			October						Dec.
	9	30	30	1	2	2	5	8	10	24
Station No.	31	50	58	70	78	94	110	122	136	90°S
Surface elevation (m)	961	1203	1279	1393	1487	1623	1745	1881	1933	2800
Sweep range ( $\mu$ s)	25	25	25	25	25	25	25	25	25	25
Counter time ( $\mu$ s)	10.4	13.9	9.2	10.4	6.8	Nil	Nil	Nil	Nil	Nil
Oscillo. time. ( $\mu$ s)	10.4	5.5	9.0	6.1	6.8	6.2	12.0	18.4	Nil	Nil
		13.9	14.0	10.0	19.4	11.0	15.6			
				19.3		18.2	(21.0)			
Seismological ice thickness (m)	877	1177	1185	1631	1639	1542	1317	1553	1864	
Calculated group velocity (m/ $\mu$ s)	168.4	169.2	169.1	169.3	168.9	179.3	168.8	168.9		
Bottom elevation (m)	+84	+26	+94	-238	-152	+81	+428	+328	+69	
Surface temp. (C°)	-31	-33	-34	-30	-32	-32	-29	-34	-34	-29
Surface snow density (g/cm)	0.41	0.41	0.42	0.40	0.40	0.41	0.41	0.41	0.42	0.36
Surface snow hardness (kg/cm)	27	27	27	26	?	?	?	26	20	3.7

10 points on their route, using this equipment. The results are shown in Table 2. The values given in this table have been recalibrated by comparison with the accurate frequency standard and an accurate attenuator after each trip.

As shown in Table 2, the average group velocity of the radio waves propagating through the ice is evaluated at 169.1 m/ $\mu$ s by comparison with the most reasonable value of the seismological ice thickness. This is in good agreement with the theoretical value (JIRACEK, 1967).

The output power of this equipment (1 kW, PEP) was only sufficient to extend the measurement to the depth of 1,800 m.

On the return trip, the power transistor for the DC-DC convertor of the power unit (2N1163As), which was mounted on the sledge and exposed to the cold atmosphere, has gone wrong.

#### References

- EVANS, S. (1964): Radio echo sounding of polar ice sheets. *Nature*, **204**, 420-421.
- EVANS, S. (1965): Dielectric properties of ice and snow; A review. *J. Glaciol.*, **5** (42), 773-792.
- JIRACEK, G.R. (1967): Radio sounding on antarctic ice. *Res. Rep. Ser. Univ. Wis.*, **67** (1), 1-127.
- LLIBOUTRY, L. (1966): Bottom temperatures and basal low-velocity layer in an ice sheet. *J. Geophys. Res.*, **71** (10), 2535-2543.
- WAITE, A.H. and S.J. SCHMIDT (1961): Gross errors in height indication from pulsed radar altimeters operating over thick ice or snow. *IRE Int. Conv. Rec.*, **5**, 38-54.
- YOSHINO, T. (1961): Radio wave propagation on Antarctic ice cap. *Antarctic Rec.*, **11**, 228-233.
- YOSHINO, T. (1965): The reflection properties of radio wave on polar ice cap. *IEEE Int. Antenna Propagation Symp.*, 48-51.
- YOSHINO, T. (1967): The reflection properties of radio waves on the ice cap. *IEEE Trans. Antenna Propagation*, AP-15, 542-551.