

**UCC Library and UCC researchers have made this item openly available.  
Please [let us know](#) how this has helped you. Thanks!**

<b>Title</b>	Status of micro/mini-grid systems in a Himalayan nation: a comprehensive review
<b>Author(s)</b>	Shrestha, Ashish; Rajbhandari, Yaju; Khadka, Nasib; Bista, Aayush; Marahatta, Anup; Dahal, Rojesh; Mallik, Jiwan Kumar; Thapa, Anup; Hayes, Barry P.; Korba, Petr; Longatt, Francisco M. Gonzalez
<b>Publication date</b>	2020-01
<b>Original citation</b>	Shrestha, A., Rajbhandari, Y., Khadka, N., Bista, A., Marahatta, A., Dahal, R., Mallik, J. K., Thapa, A., Hayes, B. P., Korba, P. and Longatt, F. M. G. (2020) 'Status of micro/mini-grid systems in a Himalayan nation: a comprehensive review', IEEE Access, 8, pp. 120983-120998. doi: 10.1109/ACCESS.2020.3006912
<b>Type of publication</b>	Article (peer-reviewed)
<b>Link to publisher's version</b>	<a href="http://dx.doi.org/10.1109/ACCESS.2020.3006912">http://dx.doi.org/10.1109/ACCESS.2020.3006912</a> Access to the full text of the published version may require a subscription.
<b>Rights</b>	© 2021 the authors. This work is licensed under a Creative Commons Attribution 4.0 License. For more information, see <a href="https://creativecommons.org/licenses/by/4.0/">https://creativecommons.org/licenses/by/4.0/</a> <a href="https://creativecommons.org/licenses/by/4.0/">https://creativecommons.org/licenses/by/4.0/</a>
<b>Item downloaded from</b>	<a href="http://hdl.handle.net/10468/12896">http://hdl.handle.net/10468/12896</a>

Downloaded on 2022-05-18T20:06:25Z

Received June 13, 2020, accepted June 30, 2020, date of publication July 3, 2020, date of current version July 15, 2020.

Digital Object Identifier 10.1109/ACCESS.2020.3006912

# Status of Micro/Mini-Grid Systems in a Himalayan Nation: A Comprehensive Review

ASHISH SHRESTHA<sup>1,2</sup>, (Member, IEEE), YAJU RAJBHANDARI<sup>1</sup>, NASIB KHADKA<sup>1,2</sup>, AAYUSH BISTA<sup>1,2</sup>, ANUP MARAHATTA<sup>1</sup>, ROJESH DAHAL<sup>3</sup>, JIWAN KUMAR MALLIK<sup>4</sup>, ANUP THAPA<sup>1</sup>, (Member, IEEE), BARRY P. HAYES<sup>5</sup>, (Senior Member, IEEE), PETR KORBA<sup>6</sup>, (Senior Member, IEEE), AND FRANCISCO M. GONZALEZ LONGATTI<sup>7</sup>, (Senior Member, IEEE)

<sup>1</sup>Department of Electrical and Electronics Engineering, Kathmandu University, Dhulikhel 45200, Nepal

<sup>2</sup>Centre for Electric Power Engineering, Kathmandu University, Dhulikhel 45200, Nepal

<sup>3</sup>Chilime Hydropower Company Ltd., Kathmandu 44600, Nepal

<sup>4</sup>Alternative Energy Promotion Center, RERL Project, Government of Nepal, Kathmandu 44600, Nepal

<sup>5</sup>School of Engineering, University College Cork, Cork, T12 YN60 Ireland

<sup>6</sup>School of Engineering, Zurich University of Applied Science, 8401 Winterthur, Switzerland

<sup>7</sup>Department of Electrical Engineering, Information Technology and Cybernetics, University of South-Eastern Norway, 3918 Porsgrunn, Norway

Corresponding author: Ashish Shrestha (ashish.shrestha@ku.edu.np)

This work was supported by the EnergizeNepal Project Office, Kathmandu University, Nepal, under Grant PID: ENEP-RENP-II-19-03.

**ABSTRACT** Nepal is a Himalayan country with its 83% of its geography being composed of hills and mountains. Around 22% of the Nepalese population is not receiving electricity through the national power utility and is forced to identify alternative approaches to electrification. The Micro/Mini-Grid (MG) system is one of the promising approaches in terms of cost, reliability and performance for rural electrification, where electrification through national power utility is not techno-economically feasible. However, various issues must be identified and considered during the implementation of MGs in a rural community. In this paper, numerous technical, social and management issues are identified and discussed relating to the implementation and operation of reliable and stable MGs in the Himalayas. To our knowledge, this is the first scientific work that presents a comprehensive review of Himalayan MGs and their associated elements. This article reviews the available research articles, project documents, and Government reports on MG development, from which a clear roadmap is constructed. From the comprehensive study, it is observed that the existing MGs are not adequately designed for the specific area, considering the local resources and local information. Based on the identified issues, some practical and efficient recommendations have been made, so that future MG projects will address the possible problems during the design and implementation phase.

**INDEX TERMS** Control management, distribute generation system, isolated energy system, mini-grid, rural electrification.

## I. INTRODUCTION

Although Nepal has enormous potential to generate electricity from different renewable energy resources, around 4.5% of the population is still out of reach to electricity [1]. One of the main reason behind it is the mountainous geography of the country; more than 60% of the population are living in the hilly area, resulting in complications in supplying the electricity through the national utility grid [2]. In such cases, the isolated energy system is found to be a

suitable solution to provide electricity [3]. However, there are numerous challenges in isolated energy system such as high-cost, poor reliability, weak power quality, low load factor, poor maintenance, weak institutional structure lack of proper monitoring and supervision etc. [4]–[6]. As the nature of Renewable Energy Sources (RES) is fluctuating and highly dependent on weather, the generated energy is also unpredictable, which can be addressed via the integration of storage devices or/ and by interconnecting multiple energy resources [7]–[9]. An optimized hybrid energy system is quite promising techniques on behalf of cost, power quality and reliability to provide the electricity to the area where an

The associate editor coordinating the review of this manuscript and approving it for publication was Daniela Cristina Momete<sup>10</sup>.

expansion of national utility grid system is quite complicated and expensive [10]. It can be made more efficient and cost-effective by reducing the disadvantages associated with these technologies [7]. However, there are other technical issues in isolated energy system such as; low load factor, low diversity factor, less reliability, protection, etc. A study identified that the MHPs having less than 100 kW capacity does not provide profit under isolated cases in Nepal since it only covers O&M costs, interest on loans and salaries for operation and management [11]. These issues can be addressed by introducing the concept of MG [9]. It is proven that the MGs contribute to improve the social developments by enlightening the local governance structure. This process contains the direct participation of local communities to guarantee the sustainable operation of that system [9], [12]. Effective power management of primary energy resources, Energy Storage Systems (ESS), and different categories of load types connected in a MG system may be a good option to resolve such problems [5], [12]. However, it requires to be techno-economic feasible to operate the energy system to maintain the overall system efficiency and healthy performance under an isolated scenario [13], [14]. In Nepal, the MGs developed through the interconnection of multiple MHPs are technically feasible, but it must be scale-up to get financial sustainability [15]. Access to energy helps to utilize the local energy sources, create the revenue by selling energy and provide employment, respond to public interest and concern about the environmental issues, and reduce the greenhouse gases [16]. Hence, energy access in the local area can contribute to increase the economic status, literacy rate, living standards, and reduce the environmental and health problems that arise from pollution [6], [17].

However, the current MGs and energy systems at the rural areas are concerned to fulfil the fundamental lighting objectives (i.e. Tier 3 or below, as per the Multi-Tier Framework (MTF) study by World Bank) [18]. In this stage, the studied energy system is not able to provide reliable and stable electricity to the communities. Even in the communities connected with some form of the energy system, are facing the problem of power deficit and instability [19]. In Nepal, the practice of rolling blackout is prevalent to maintain the demand/ supply chain in such area. In some of the region, the consumers are requested to operate the electrical appliances under 100 watt per household at peak demand period [18], [20]. One of the main reason of insufficient power in rural communities is a lack of proper planning toward future demand. Further, a high rate of equipment failures is occurring in the household side as well as energy system side, because of the reduced power quality and weak protection guideline [21], [22]. It was observed that a big proportion of isolated power plant are not in function because of some failures and not repaired for an extended period. This is due to a high failure rate in Nepalese MGs and in consideration of the management system toward the sustainable operation of plants [23], [24]. Also, most of the control mechanisms in the Nepalese energy system are manual, and

the restoration process is complicated and time-consuming. Because of these numerous issues, rural communities are still facing problems regarding reliable and stable electricity access.

In this scientific paper, the authors aim to offer comprehensive information on the existing and potential MG developments in Nepal and the South Asian countries. Besides, this paper aims to present the current issues in the development and implementation of MGs in developing nations with their possible solutions. This study first introduces the background on of energy system along with its importance in humanity. Further, the importance of a reliable energy system has been discussed with the co-relation of associated factors such as cost, availability, security, social aspect, nature of MGs etc. Section 2 gives an overview of MG system in rural Nepal and other South Asian countries, which includes the detail proportion of the existed systems. Section 3 covers the adopted topologies and existing control systems for the continuous supply of the energy. Similarly, adopted protective devices and issues on protection management are presented in Section 4. Section 5 explains the structure of a functional group and adopted trading practices for the smooth operation of the energy system. Numerous issues on development and operation of such systems are explained in Section 6. Finally, in Section 7, conclusions are drawn and presented. Though described in detail, the following are the main contributions of this paper:

- a. The issues that commonly occur in MGs of Nepal and other South Asian countries are identified. These create numerous challenges to provide reliable and stable electricity in rural areas.
- b. Potential practical solutions have been discussed in detail so that the rural communities will get continuous electricity supply with a standard quality.

## II. STATUS OF MINI GRID IN RURAL NEPAL AND OTHER SOUTH ASIAN COUNTRIES

Rural electrification can be carried out either through grid extension or isolated RES such as mini and Micro Hydropower Plant (MHP), Solar Photovoltaic (SPV), wind energy, biomass gasifier etc. [25]. As an extension of utility grid line to these areas is a long way from generating system or distribution station. RES has placed a firm foundation to supply the electricity in the communities and village around the rural areas of Nepal and other South Asian countries. Figure 1 shows an administrative map of South Asia that contains eight countries making the South Asian Association for Regional Cooperation (SAARC). It presents the information on the percentage of the population getting electricity access through various type of energy sources. As per the data from the World Bank, at 2017 97.09% of Afghan, 81.28% of Bangladeshi, 96.76% of Bhutanese, 89.3% of Indian, 99.86% of Maldivians, 94.74% of Nepalese, 54.13% of Pakistani and 96.99% of Sri-Lankan population living in the rural area were getting electricity access via different medium [1]. On the other side, Figure 3 presents the trend of

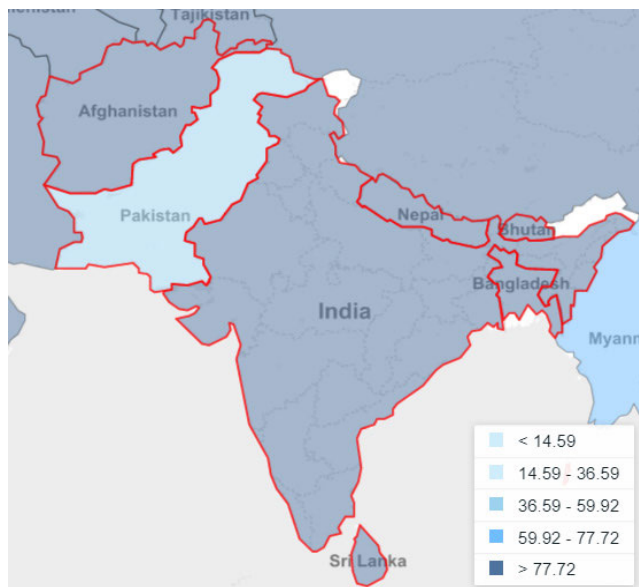

FIGURE 1. South Asian countries with the percentage of electricity access by population percentage [1].

energy access proportion by South Asian countries between 2005 and 2017. From the Figures, it is clearly shown that all of the South Asian countries except Pakistan, progressed rapidly in the field of energy generation, distribution and utilization. There is no significant improvement by Pakistan in terms of energy access percentage by the people in between the period. Among these eight countries, six countries except Sri-Lanka and Maldives contain Himalayan and hilly areas, where a significant proportion of population stay, whereas the Sri-Lanka and Maldives contain many islands. From the point of geographical, environmental and social view, the countries have variations, but similar problems exist in the electricity access prospective. The present status of MGs in all of the South Asian countries is presented in Table 2.

Focusing toward Nepal, till date more than 55 MW of electricity has been produced from MHP and Solar energy providing access to 3.6 million households which accounts to 18% electricity access by the population [26]. With the establishment of Alternative Energy Promotion Center (AEPC) in 1996 [27], development in mini and micro hydropower, solar PV and wind generation has taken sudden pace. Notably, during the electricity crisis that begins in 2006, when Nepal suffered rolling blackout up to 16 hours in a single day at the dry season, people have shifted their trust to Solar PV and MHP to fulfil their electricity demands [28]. Since then, several programs have been launched, and different companies have invested in promoting RES. Programs such as Renewable Energy for Rural Livelihood (RERL), South Asia Sub-regional Economic Cooperation (SASEC), Renewable Energy for Rural Areas (RERA) under AEPC have been working on electrifying the rural communities in Nepal [29]. Till 2018, AEPC led more than 1,700 community-owned off-grid micro/mini-hydropower plants of around 30 MW

and more than 600,000 solar house systems in rural Nepal to guarantee the basic lighting requirements via various projects [30]. Similarly, programs such as RERL and SASEC are working together to develop 4.5MW of mini-hydro and 500kWp of solar MG projects, out of which 165kWp solar MGs are completed, and 310kWp are under construction [31]. Along with these projects launched under the program of AEPC, some other organizations have also installed their energy generators supported by solar PV, wind turbine, diesel generator sets, bio-mass generators etc. Figure 2 indicated the list of MHPs, solar and solar-wind hybrid energy system installed by AEPC since 2016. Total of 87 generation plants had been installed, and providing electricity to 41,076 households with a total generation of 4,225.2 kW. These systems are only limited to project completed under AEPC.

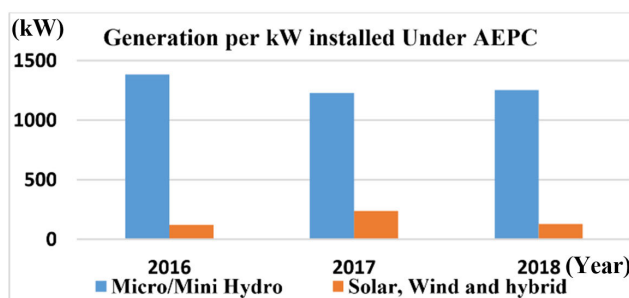

FIGURE 2. Installed isolated energy system developed in between 2016 and 2018 [31]–[33].

If viewed in terms of development in renewable energy generation, development of MGs is found to be with lacked pace. As seen from Table 1, more than 20 MHPs had been installed, adding more than 1,000kW per year between 2016 to 2018. In the current context, more than 400,000 population in Nepal rely on micro-hydro for electricity supply and still growing. However, these independent MHPs have particular limitation such as low load factor, poor reliability, frequent unsustainability issues etc. during the operation of larger loads. One of the practical solution to overcome these issues may be the development of MG system by interconnecting the locally available MHPs in a single grid [58].

TABLE 1. List of MG installed in Nepal until 2019 [31]–[36].

Type of Generation Sources	Number of Installed systems	Capacity (kW)	No. of Household
Micro/mini hydro	3	1,144	7,796+
Solar-wind	10	333.2	409+
Solar only	20	554.6	1,400+
Solar-wind-hydro	1	28	170+

A pilot project installed in Baglung, Nepal, where six MHPs previously running in isolation mode with sizes ranging from 9 kW to 26 kW were connected to a local grid,

TABLE 2. Status of MGs in the South Asian countries.

Country	Mini-grid Status		Special Features	Reference
	Economical/ Financial aspect	System performance aspect		
Nepal	The government provides a subsidy to develop the system, but the community must operate and manage by themselves. It is found to be impracticable to operate and manage the system with local resources only. Systems need to be scaled-up to get the expected outcomes.	MG suffered from both technical and managerial problems which led to low reliability in electricity supply resulting in lack of interest to invest in productive uses of electricity and thus low revenue generation barely covering even operation cost.	Nepalese MGs has been prioritized by interconnecting multiple power producers and consumers to improve performance. Almost all of the systems are shifting toward AC and modified into a commercial mode with some defined tariff rate.	[4, 6, 15, 37]
India	Governmental bodies are receiving special incentives to promote the development of MGs, since they can often provide energy access more cheaply than transmission through a grid. However, the energy purchase costs are found to be high, and problems have been arisen in collecting revenues and non-technical losses. Since the consumers use the lighting loads only, the tariff is comparatively low and fixed.	Deliver reliable power at a higher quality, but it requires build-out of the same local distribution systems with regular power supply, which leads the higher cost. Almost all of the MGs consist of an automatic back-up system to guarantee reliability. The MGs minimized the transmission losses, but there are substantial non-technical losses. Some of the latest MGs consist of smart meters that help to operate and monitor the system performances.	Basically, solar/ MHPs/ wind/ diesel based MGs have existed, but some company are integrating biomass/ biogas to provide continuous load demand. The MGs are self, community-based and/ or business-oriented. Some of the MGs allow smart metering with the integration of the prepaid concept.	[38-41]
Bangladesh	All of the MG projects are being observed, supported and managed by the Governmental body. Each solar-based MG project gets 50% of subsidy and 30% of balance supplied long term loan from the governmental side with the help of various donor agencies. All of the consumer connected with MGs get subsidies in tariff, and charges with the same rate. There are some private developers as well who build, own, operate and maintain the system.	Bangladesh defines the MG, the system having a solar PV system with a rating of 100 kW to 250 kW. The reliability and grid quality is ensured by using a battery bank and diesel set as the back-up source. The distribution system contains 3-phase, 4-wire network within a length of about five to seven km. The bidirectional inverters are placed to convert the AC/DC power between storage devices and grid.	Prepaid meters have been adopted, and the consumers are suggested to use mobile money to recharge the amount.	[42, 43]
Pakistan	Solar based mini-grid has been in practice that provides the required electricity to the rural communities and contributes to economic and social improvement. However, the IPP and private parties are not permissible to produce and sell the electricity without governmental body approval. Limited knowledge of market potential, resulting lack of financing and government support, due to which there are higher perceived commercial risks and investment costs. Although there is not so impressive development, the developers want to handover the existed system to the beneficiary communities for their operation and maintenance.	Improved system's characteristics and reduces the failure rates. However, most of the system is not designed properly required for specific demand at a place having a specific environment and resources. System loss and unconditional drawbacks have occurred frequently in the system. Different factors must be included to develop a policy and implement the mini-grid system in a real field.	Central generation and storage devices have been introduced with power delivery plan. Latest systems introduce the smart metering technologies with advanced concepts including demand-side-management, auto-switching, prepaid billing etc.	[44-47]
Afghanistan	As a part of ruler electrification policy, the local communities are encouraged to take the ownership of the MGs, resulting most of the MGs are owned and managed by the beneficiary communities. It is assumed to be a good initiative, since the community-based approaches help to integrate the system to the grid as well as to improve the social and economic development. However, there are no proper financial partners such as government, donor agencies, banking sectors and local micro-credit programs that support in the development activities by providing necessary finance, infrastructures and legal supports.	Solar and MHP based MGs and solar home systems are used for household lighting, water pumping purposes. Most of the MGs contains the diesel generator and battery bank as the back-up source. The system will be automatically operated during the peak and off-peak period by triggering the generator and battery bank connections. An algorithm and switching mechanism have been introduced to provide efficient performance. On the other side, there are some technical and commercial barriers such as: (a) Limited capacity of the grid to accommodate RES, (b) Lack of electricity demand data to identify the suitable location for MGs, (c) Land issues, (d) Investment and financing issues, (e) Unclear policy and guideline etc.	Equipped with optimized MG simulations and control set-ups. The system has features to optimize the system's performance on a real-time basis, based on which the system can manage the load and generation side by proper switching.	[48, 49]



TABLE 2. (Continued.) Status of MGs in the South Asian countries.

Country	Mini-grid Status		Special Features	Reference
	Economical/ Financial aspect	System performance aspect		
Bhutan	Although Bhutan produces excessive electricity from hydropower plants and sells it to India, all of the rural households do not get the electricity properly. This situation arises because of the mountainous terrains that create difficulties in an extension of the national grid all around the nation. The rural people are getting electricity through the solar home system with some subsidy provided by the government and some donor agencies. A few community-based projects have been piloted to observe the system performances and get feedback from local communities. However, such systems face the problems of unavailable skilled workforce at the remote area to operate the system in a sustainable model.			[48, 50, 51]
Sri-Lanka	More than 250 community-owned isolated MG projects with financial support from government and World Bank were installed between 1997 and 2012, but when national utility’s grid reached villages, these MGs were abandoned. Setting tariffs too low are one of the main reason to maintain commercially sustainable operations over the long run. Sri Lanka’s national electricity law prohibits MGs from making retail sales once the main grid arrives and currently 98% of the population are in reach of the national utility grid. Bioenergy and solar energy are being introduced as solutions to reduce Household Air Pollution (HAP).			[52, 53]
Maldives	The Maldives is one of few countries along with Nepal, Kenya, Uganda, Tanzania, Mali and Liberia for up-scaling MGs for least cost and timely access to electricity services. The Maldives is a country consisting of 1190 tiny islands have their stand-alone power system, mainly powered by diesel. This stand-alone system can also be considered as MG. Potential renewable energy (RE) resources in the Maldives are Solar, Wind and Biomass. Some islands that are transformed into resorts are using solar photovoltaic cells to generate power privately. Currently, renewable energy target applications are limited to some applications of solar photovoltaic cells in navigation lights and outer island telecommunication systems.			[54-57]

Access of Electricity (% Population) of South Asian Countries

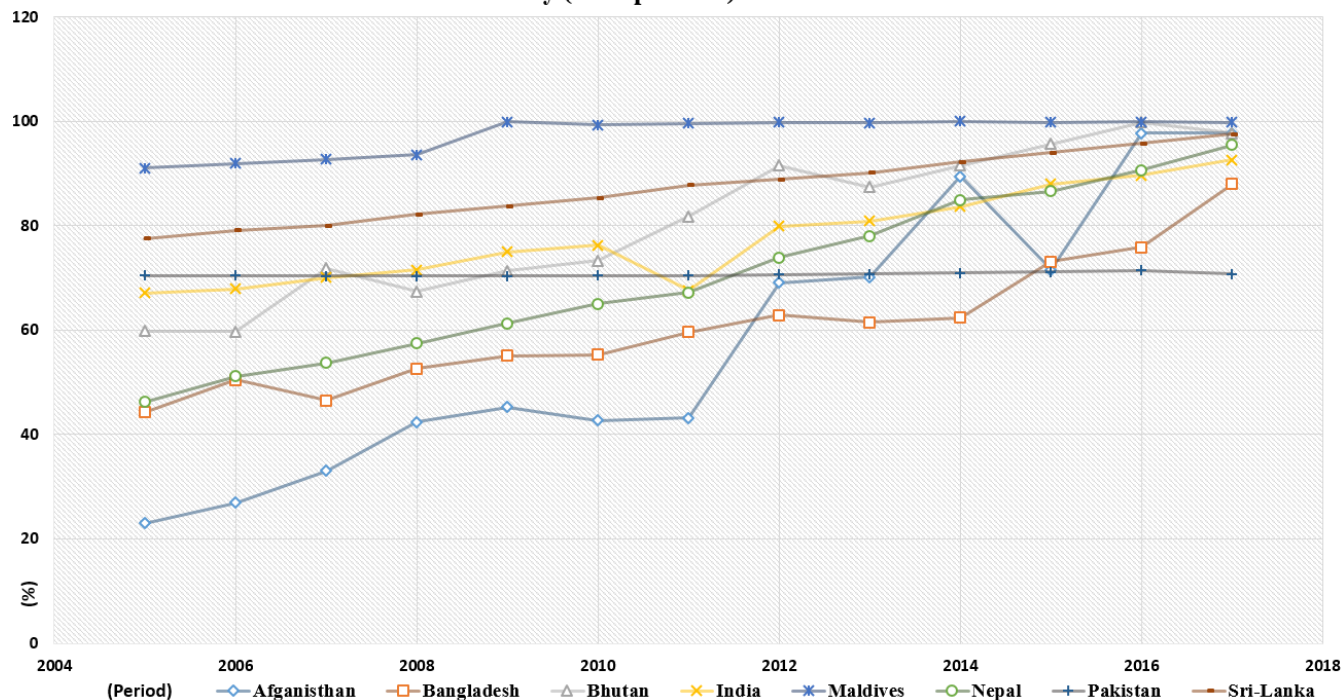

FIGURE 3. The trend of energy access by population percentage in South Asian countries between 2005 to 2017 [1].

forming an MG power system of 11kV with total grid power of 107kW [59]. Similarly, another project interconnection two micro-MHPs was completed in Gulmi at 11kV transmission line extending 1.5km. One of the biggest ongoing projects of Nepal is in Taplajung that will connect 6 micro and mini-hydropower plants of commutative capacity of 823kW. This project had completed its 37km of 11kV transmission line, and till December 2018 it has connected three of the MHPs successfully. The grid connecting of interconnected

MHPs will help to generate the additional revenue for the MHPs and avoid transmission losses of the national utility [31]. A study [11], discusses a few of the possible interconnection of MHPs to improve the supply and fulfil the demand which is not completed by stand-alone micro-hydropower. It also discusses the techno-economic analysis of the proposed Micro Hydro Interconnected MG (MHIMG).

On the other side, development in solar-based MG has also increased in high number in the recent era. AEPC has also

been working on solar MG projects. Alongside AEPC, private companies such as Gham Power establish its first solar-based MG of 70kW capacity located at Khotang in 2014. With this, they have installed and supported in installing nine more solar MGs until 2018 [36]. As an initiation AEPC installed an 18kW solar MG as a pilot project under Pro-Poor-Public-Private-Partnership (5P) concept in 2016. Since then, AEPC has worked on many solar MGs around Nepal providing financial and technical assistance. There is a total of 26 known solar plus hybrid MGs installed by AEPC [31]–[34], [36], [60]–[62]. The capacity of such systems ranging from 5 kW to 100kW, and supply electricity to more than 1000 HHs. Malladehi Solar MG (30kW), Sugarkhal solar MG (75kW) and Saptami solar-wind hybrid (70kW) are the latest projects of AEPC under the SASEC. Other integrated MG line in Nepal includes Solar and wind-based MG lines. A hybrid micro-grid installed at Nawalparashi includes two wind turbines of 5kW and Solar PV array of 2.1kW supplying electricity to 46 HHs. Total of ten such hybrid connections has been noted by AEPC with capacity ranging from 80kW in Narakot to 7.2 kW Harrekanda solar-wind-MG, Surkhet, supplying electricity to more than 400 households along with few industries [31]–[34], [36], [60]–[62]. Similarly, a tri-hybrid system has also been in used since 2012. Thingan Miteri Hybrid MG was installed which is powered by 20kW MHP, 5kWp PV system and a 3kWp wind turbine, supported by battery back-up. This grid line extended seven km from the point of generation and supplying the electricity through three substations [35].

### III. CONTROL TECHNIQUES AND TOPOLOGIES

The electrical system in a MG is assumed to be radial with several feeders and a mixture of different loads. The MGs consist of micro/ mini-sources including micro-turbines, wind generators, photovoltaic arrays, fuel cells etc. A typical MG topology is shown in Figure 4. In a MG, generally, there are two modes of operation: grid-connected and grid-islanded operations. A grid-connected operation of a MG system follows the distribution rules of the network without operating the central power system. In this system, the MGs can draw power from the primary grid or supply power to the main grid and works like a controllable load or source [63]. In Islanded operation of MG, the units can be controlled based on a decentralized approach balancing the generated energy and the demand. In this mode, the system must balance supply and demand with acceptable power quality, maintaining voltage and frequency [64]. This mode also helps in reducing main grid transmission and distribution costs in off shore or remote areas.

From the prospect of control mechanism, the MG can be defined as a combination of the Distributed Energy Resources (DER), power interface converters, prime energy movers and non-linear loads, and the system capable of solving system glitches locally [65]. For the control of MGs, different control approaches have been used, currently in practice are

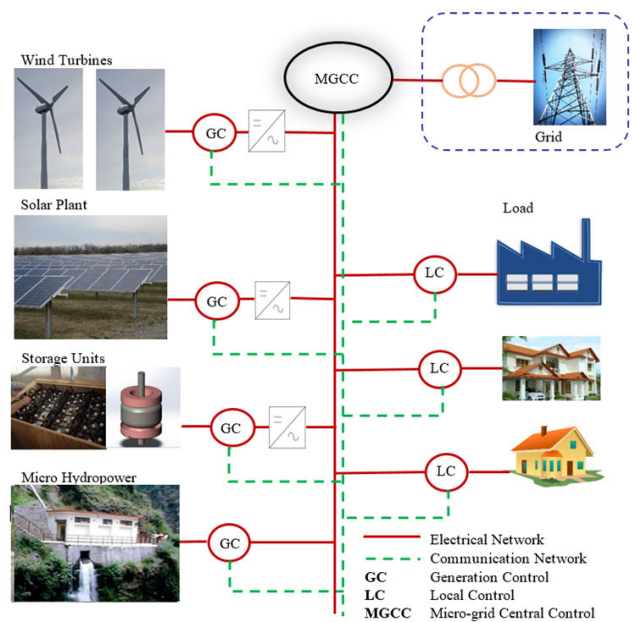
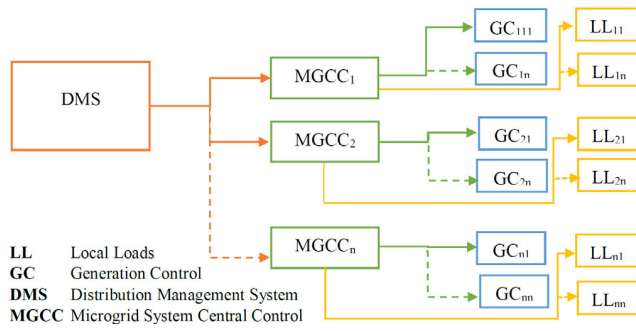

FIGURE 4. A typical topology of MG.

centralized and decentralized control topologies [66]. The completely centralized control mechanism relies on the collected information, and performs the required calculations to identify and provide the control task for all the units within a single point. It requires extensive communication among the central controller and the controlled units [66]. It manages DER, ESS and loads, to monitor and control the entire MG [67]. The power utilities usually cover a big geographic areas, and adopting the fully centralized approach, which may infeasible because of the extensive computation and communication needs [66]. For the general operation of the system, a centralized control system can be defined as hierarchical control system consisting of three control levels: Generation Controllers (GC) and Local Loads (LL), MG Central Control (MGCC), and Distribution Management System (DMS) which controls all other levels of hierarchy [68]. With central control of MG, a significant benefit in energy marketing can be obtained as the central system that determines the power flow within the topology. Figure 5 provides an insight into the central control system. In this type of control mechanism, power reliability and stability is guaranteed by the primary control or DMS.

On the other side, the decentralized approaches are based on enhanced functionalities of local Distributed Generation (DG) controllers, that compete to maximize their production and system efficiency [68]. For a geographically dispersed system, where a highly complex system like centralized is not realizable due to geographical constraints, these systems tend to use decentralized systems, which is more favourable in remote and disperse areas like in Nepalese MGs. In these areas, a piece of information from the central control system is not available [69]. Whereas in a decentralized control system, each of the units is monitored and



**FIGURE 5.** A typical topology of central control system in a MG generation control.

controlled by their respective controller. This type of control system only receives the local information, and is neither aware of the system-wide variables nor the action of other controllers [70]. The decentralized approach is also not possible because of the strong coupling between various operations that require a minimum level of coordination, which cannot be achieved from local variables [66]. The locally managed decentralized control guarantees the stability of the whole system in such cases. The common quantity in all cases of decentralized control is the steady-state frequency, which must be the same for all sources. In grid-connected mode, the MG frequency is decided by the grid, and in islanded mode, the frequency is decided by the MG control [71]. Figure 6 shows the decentralized radial MC topology. The hierarchical control scheme can achieve the concession of centralized and decentralized control schemes through different control levels: primary, secondary, and tertiary [65], [66], [72].

- a. **Primary control level:** It is the first level in the control hierarchy, featuring the fastest response [66]. The primary control responds to system dynamics and ensures that voltage and frequency track their set points. It mainly relies on locally measured signals and requires no communications [73]. There are two aspects of primary controllers; input-end-controller and grid-end-controller. The input end controllers are responsible for pulling highest utilization from DGs and the grid-end-controllers are responsible for managing real power transfer to the grid, managing the DC linked voltage, power grid harmonization and the line impedance recognition [65].
- b. **Secondary control level:** Secondary control, also referred to as the MG Energy Management System (EMS), which is responsible for the reliable, secure and economical operation of MGs that ensure the power quality and mitigating the long-term voltage and frequency deviations [66], [74]. Besides, it may target other major objectives to control the system for power quality improvement, voltage profile improvement, and efficient reactive power-sharing and loss reduction. This level of control facilitates the synchronization

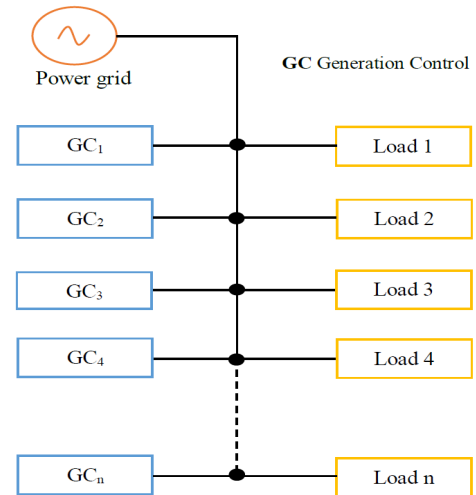

**FIGURE 6.** A typical topology of decentralized control system in a MG.

of MGs with the primary grid [74], and also determines the set point of voltage and frequency for primary control [73]. In the case of energy deficiency, techniques like Demand Side Management (DSM) and load shedding are used to keep the grid in operational mode [29].

- c. **Tertiary Level Control:** This is the highest level of control mechanism in MGs, and only exists in MGs with grid integration. The primary function of the tertiary level control is to coordinate the power flow between the MGs and maintain the healthy operation of the whole system. It also supplecates demand-supply balancing through an optimum energy flow controller [65], [66], [74].

In rural Nepal, different DGs such as MHP, solar PV and wind turbine are considered to be the primary source of energy. Among these, five combinations are found to be in practice to provide the energy excess in rural Nepal: (i) solar-based, (ii) wind-based, (iii) solar-wind hybrid, (iv) solar-micro-hydro hybrid and (v) solar-wind-micro-hydro hybrid [29]. These energy combinations are mainly controlled via two approaches: (i) Voltage and frequency control, and (ii) DG coordination and grid control. In MHPs, Electronic Load Controller (ELC) or Automatic Voltage Regulator (AVR) is used for voltage and frequency control. There is a constant input of water to the MHP turbines unless adjusted by using a butterfly valve, and the frequency balance is carried out through adjusting dummy load (also known as ballast load) [75]. At the consumer side, the loads are controlled by the switching of power electronic devices [75], [76]. Generally, the MHPs use AVR based controllers that regulate output voltage by controlling the excitation voltage of generators [59]. On the other side, solar and wind-based MGs are controlled through the integration of inverter. The system use voltage source inverters (VSCs) with the ability to mimic the inertial characteristic of a large generator for improved stability [29]. The inverter control within the Power Electronic Converters (PEC) can be categorized into three modes:



(i) grid forming, (ii) grid feeding, and (iii) grid supporting both grids forming and grid feeding. The biggest MHP operates in the grid forming mode and rest of the energy sources are operated in grid-feeding mode. In the MGs containing no MHP, the battery is operated in the grid-forming mode, and the remaining energy sources are in grid feeding mode. The power flow at the point of coupling point is controlled by a central controller, and the modes of operation of DGs are also controlled by the central controller [77].

#### IV. PROTECTION ISSUES AND THEIR SOLUTION

Every electrical network needs to be protected from the unusual current and voltage fluctuations within it. Sometimes these fluctuations are explained by unusual spikes seen due to the unforeseen event like lightning. From the report prepared by the Department of Hydrology and Meteorology of Nepal [78], in the year 2018, 143,261 clouds to ground strike were noted in overall Nepal covering an area of 147,181 km<sup>2</sup>. With such high cloud to ground strikes in Nepal, it is clear that electrical power networks, including MGs are vulnerable to such lightning hazards. Not only due to the lightning, but electrical networks are also prone to switching surges as well and proven to be more frequent one than the lightning surges. Switchgear and protection devices like relays, contactors, circuit breakers do isolate system after overvoltage and over-current. However, the transient electromagnetic effect before and during the operation of such a system has not been well addressed in the current practice of Nepalese MGs. The reason behind surge protection of Nepalese MG system getting less attention is due to cost minimization, fragile policies, and lack of quality engineering consultancy. In a study done under power system protection assessment of MGs in Nepal [79], it was noted that the selected case study had faulty Module Case Circuit Breaker (MCCB), which infers that MGs with increased risk factor suffer from high-frequency transients of lightning current and as a result, various sensitive equipment are exposed to complete energy dissipation of surges leading to operation failure. The technical experts in the field of MGs in Nepal realized that the equipment with a low value of Basic Insulation Level (BIL) like ELC, display panels are more likely to be affected from lightning strikes. From the experience of Baglung MG, which is facing technical issues regarding the failure of various equipment in powerhouse and substations, it is suggested to have proper guidelines and standards for new MG projects [25]. Hence, an immune protection system is a must to protect the different sections of the entire MGs from high-frequency transient spikes seen due to lightning and switching incidences.

Equipment of medium voltage and low voltage network of the MGs must be protected with the suitable lightning arresters coordinated per industry practices as in IEEE C62.22 [80]. Rotating machines in MHPs of the MGs can be protected by using sloping capacitors in conjunction with the machine, as shown in Figure 7, which shall reduce the stress of the steep rising surges [81]. Other generating units like the solar photovoltaic system and wind turbine are more

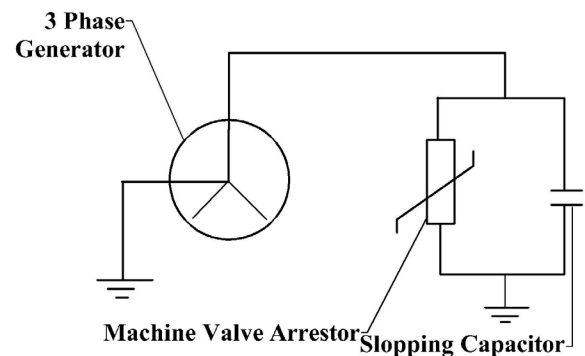

FIGURE 7. Protection of rotating machine (Generator).

likely to be hit by direct and indirect lightning strikes. The prime task to protect the PV system is to decide the protection level, ratings of Surge Protective Devices (SPD) and proper placement of the SPD. As per the review done in [82], protection of the PV system against lightning can be achieved by following the IEC 62305 [83]–[86]. The induced over-voltage developed due to lightning event hampers solid-state devices in PV inverters, which shall be prevented by using un-gapped Metal Oxide Surge Arrester (MOSA) as suggested in [87]. The external protection of the solar power plant can be achieved by installing an air termination system as shown in Figure 9, where the location of the air terminations can be decided by using the Rolling Sphere Method. According to the study based on data are taken from the WMEP database of ISET [88], 30% of the lightning faults involved in the control systems, 26.3% the electrical system, and 19.9% on the blades of wind turbine generator system. Turbine blades being situated in high heights are prone to direct lightning strikes which must withstand direct lightning attachment, full lightning current and un-attenuated magnetic field [89]. As suggested in [90], wind turbine blades can be protected from lightning by installing air termination systems on the blade surfaces as shown in Figure 8, high resistive tapes and diverters, down conductors placed inside the blade, conducting materials for the blade surface.

On having proper lightning protection system for generating units of the MGs, it is essential to protect transformers and low/medium voltage distribution line, which is directly exposed to the external environment for a long span. According to the comparative research done in [91], reducing primary arrester lead lengths (line and earth), adding primary arresters with the lowest available protection level, using surge durable fuse link (minimize nuisance fuse operation) and installation of low voltage arresters on the secondary side, it was found that failure rate decreased by 88%. Such changes, as depicted in Figure 10, shall be practised in the transformers of the MGs to protect them from lightning strikes. Similarly, medium voltage distribution lines shall be protected by using surge arresters in every 200m span of the line, which shall limit the overvoltage stress leading risk of

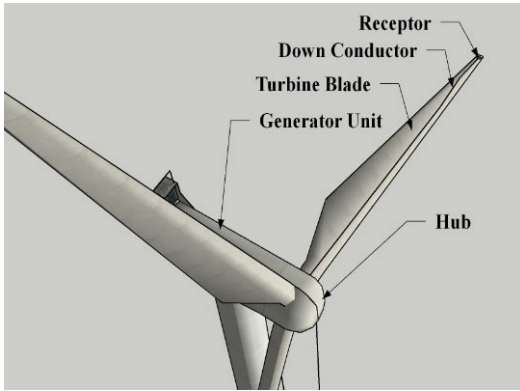

FIGURE 8. Protection of wind turbine.

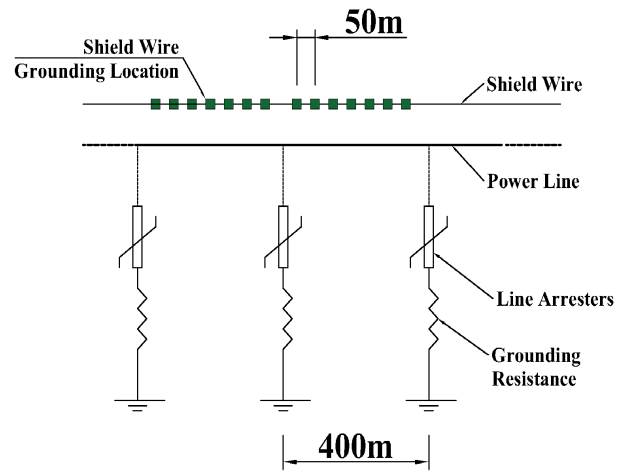

FIGURE 11. Protection scheme for medium voltage line.

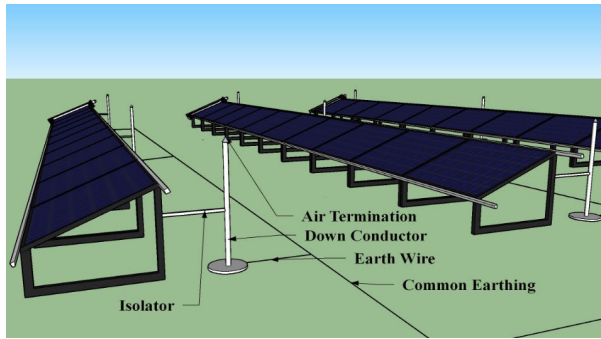

FIGURE 9. Lightning protection of solar power plant (External).

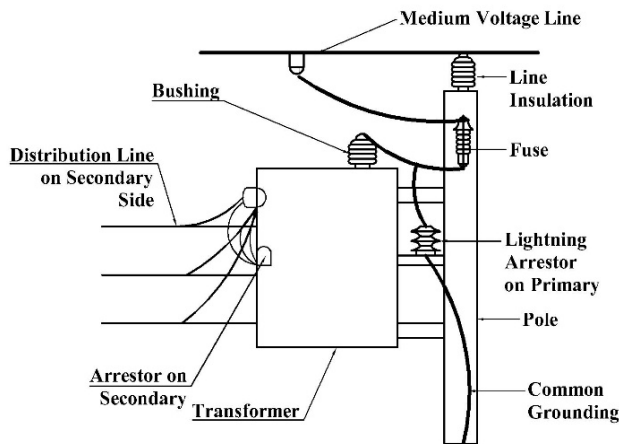

FIGURE 10. Protection scheme for distribution transformer.

insulator flashover closest to strike point below the tolerable limit (10-1). As shown in Figure 11, by placing periodically grounded shield wires in the medium voltage distribution network, surge arrester can be placed in every 400m for risk factor below 10-1 [92].

Lightning surges might travel to the distribution board of household and industrial consumers and damage the equipment connected. Household appliances can be protected using Surge Protective Devices (SPDs) with their proper placement in coordination with  $U_w$  and  $U_p$ . According to

simulation done in [93], for effective protection distance of 10m, surge arresters with  $U_p$  of 1.2 kV and  $U_w$  of 1.5 kV must be selected whereas for longer protection distance up of lower value must be selected. For the protection of industrial appliances from lightning, single MOSA based SPD should be used, which is capable of handling a large amount of thermal energy. Besides the use of lightning protection devices like lightning arresters, spark gap and SPDs, it is most to have well grounding system. According to the MG design manual [94], it is noted that the contact resistance of the grounding electrodes must be sufficiently low to ensure proper grounding. Deep driven grounding rods provide lesser grounding resistance as the rods come into tight contact with soil and resistivity of soil is low due to a high amount of moisture content. As suggested by the design manual [95], it is essential to double the grounding rod length to lower the grounding resistance by 10%. Similarly, for the soil with high resistivity, grounding electrode treated with metallic salts interfacing the periphery of the electrode shall be used, which improves the soil conductivity. Equipotential bonding can be practised for the protection against electric shock, minimization of resistive, inductive and capacitive interference, reduction of the occurrence of electromagnetic fields and implementation of high-quality measures for the equipment safety along with lightning and surge protection [96].

## V. MG MANAGEMENT AND TRADING PRACTICES

Any established body requires a proper management unit to run it sustainably; which goes same in the case of MG. As most of the MGs are operating isolated, they require a proper governing body to run the entire system smoothly. The quality of management system adopted do rely on ownership of any project. The MGs are either financed through government funds, international donation or number of stakeholders. With investors being predefined, there arise issues related to rights, responsibilities and risks involved within the system. The more the stakeholders are, the more challenges are

expected to become around while running the system unless a governing body is established. It is even more challenging to form a governing body when it comes to any organization formed with donor fund and proven to be the prime challenge for developing countries like Nepal.

Additionally, even if a governing body is formed, another topic of concern for the management committee would be the availability of funds for operation and maintenance. From a study, it is seen that 1/8 and 1/30 part of the total capital cost is required for operation and maintenance to run MGs sustainably and comply with the expected lifetime [97]. Due to the lack of robust financing and business plan, the management team fails to expend on operational and maintenance cost as required. So, it is realized that for long-lasting operation, it is required to form a governing body with well-defined delegacy of power. Additionally, financing and business model should be well planned and implemented to cope up with the routine as well as unexpected maintenance required for the soundness and continual operation of the entire system. To operate the MGs, the community-owned project has been developed with the active participation of locals. The structure begins with MG cooperative followed by plant functional group, community organization, and households, as shown in Figure 12. The MG cooperative group is responsible for operating and maintaining the whole system. The plant functional group represents the local community, and community organization organizes community meetings, collects money and conducts social activities [15], [59].

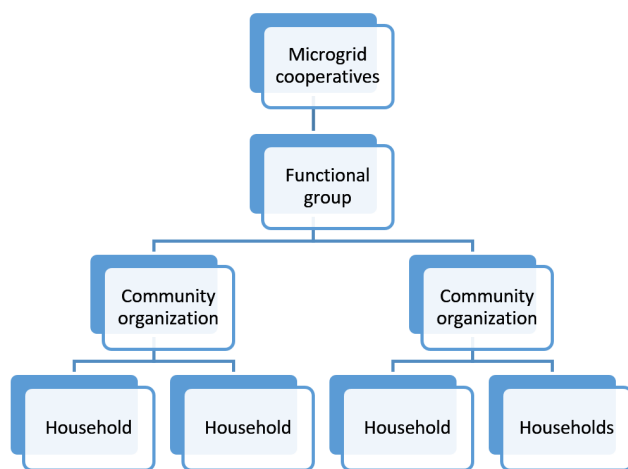

FIGURE 12. MG functional group formation in rural Nepal.

The Baglung MG is managed by two business groups: cooperative body and functional group. Cooperative body deals specifically with financing, cash flows, budgeting and every other issue related to power plant economics whereas functional body deals with technical aspects of micro hydro operation related to the structural, mechanical and electrical domain [59]. However, coordination between these two bodies has been a challenge to Baglung MG creating difficulties in problem-solving and economic stability. Whereas, in Baidi MG 5P Business Model namely flagship business model is

implemented where a committee of five members (three from the private company and two from the community) is formed for complete maintenance and operation activities. Likewise, MGs of Nepal are owned by combination among community, cooperative, private company, rural market centre, governmental bodies for the upliftment of renewable energy and the governing body is formed by elected representatives of owners [4].

In the present context, Nepal's electrical sectors are moving toward a stable and reliable system via modernization or/and up-gradation of existing DGs and grid extension [37]. Interconnection the Distributed Energy Resources (DER) increase system reliability. However, it also put forward a question on how this energy sharing and trading can be done between these sources. In the case of Baglung MG, the cooperative is fully accountable to operate the system sustainably. The cooperative has all of the crucial-decision-making-power such as: fixing PPA rate, tariff structure, office management and addressing other issues [59]. Other individual Micro Hydro Functional Group (MHFG) have been restricted to IPP. The trading arrangement for the grid is made such that MG community buys electricity from respective IPP at NPR 4.5/units and then sells to the consumer at a rate of NPR 75 for a minimum of 12 units and NPR 7 per unit above 12 units.

The tariff structures in Nepal are usually power-based or energy based in the case of MGs. These IPP in the Baglung previously used the earlier system, where the consumer paid for the charge of electricity for the according to the amount of power they used [59]. The power-based system is common in the small power plant which has generation capacity below 20 kW. Similarity system with high generation capacity used an energy-based system, where the consumer pays according to the energy consumed. The rate is different from user to user as different tariff is implemented for domestic and commercial users [11]. The Nepal Electricity Authority (NEA), national utilities have started the policy to integrate the DGs with a net meter tariffing model. Currently, the solar water pumping projects are benefited from this policy, through which, the project owners are selling the left-over energy to the utility grid. A similar concept has been applied to other IPPs also [37].

## VI. CHALLENGES IN THE IMPLEMENTATION OF MG

Since few years, Nepal has witnessed aggressive rural electrification through grid extension and development of off-grid MG systems. Recently published Multi-Tier Framework (MTF) study by the World Bank shows that only 4.5% of Nepalese households do not have access to electricity. In other words, 95.5% of households have access to electricity by one means or the other such as grid or MGs, solar home systems, solar lanterns, rechargeable batteries, etc. The same report also reveals the fact that there is only 67% of electricity access in the country while considering Tier 3 and above [18]. Thus, the question remains – how prudent is it to include solar home systems, solar lanterns, etc. under households with

electricity access? Therefore, there is an enormous opportunity for both MG development and grid extension in the country [18]. Some of the challenges for wider promotion of MG systems are [30], [37], [58], [59], [98]–[100]:

- a. **Technical issues:** All of the MGs are located in a rural area, where the availability of skilled human resources and instruments may not be possible at the right time. Similarly, the local people and the local government cannot afford expensive systems. The main issues that cause the system failures are: (i) Lack of proper maintenance and operation plan, and (ii) Inaccessible to emerging technologies and skilled manpower.
- b. **Political changes:** Local government operation act 2017 has given a mandate of implementation of RES up to 1MW to local government. The municipalities do not have the human resources and capacity to carry out new responsibilities. The governmental agencies to define the roles and responsibilities of institutions at different levels of governance viz. municipalities, provinces and federal. This anomalies in recent years have affected in large scale implementation of MG projects.
- c. **Private developers are reluctant to invest:** MGs for the last-mile community are highly subsidized, whereas large scale MGs can be developed with a proper mix of subsidy, loan and equity. In Nepal, the community has a subsidy seeking mentality. Community waits for the subsidy from federal, provincial and local governments for several months, even years in some cases as they still perceive loan as a burden. On the other hand, the private sector and banks are also reluctant to invest in the MGs.
- d. **Operational issues and payment risk:** Generally, the power producer are operated in the modality of Independent Power Producer (IPP), and the whole MG system is managed by forming a functional group. The power producers sell the electricity with a well-defined Power Purchase Agreement (PPA), and the MGs sell the electricity to the consumer with a regulated tariff guideline. Since the managing activity of a MG with multiple IPPs is itself a complex task, it requires dedicated efforts from human resources, management body and the consumers. Disagreement among these groups may distract the whole system from getting their exact outcomes efficiently.
- e. **Low productive use:** MGs are mainly used for lighting, TV, mobile charging etc. (i.e. basic electrical needs). Besides, the utilization of generated energy in the productive sector is quite low in such areas. In the particular case of the Baglung MG in mid-western Nepal, the load factor and utilization factor were calculated to be 23% and 26% [15]. These consumptive uses do not generate enough revenue to cater to its operation and maintenance. The productive uses of electricity such as milling, carpentry, cyber cafe, refrigeration etc. can help improve the livelihood of the community.

However, the productive uses of electricity seem very low compared to consumptive uses of electricity.

- f. **Limited exposure in a larger system:** AEPC which is the Nepalese government apex body for the promotion of the off-grid sector, has been limited with few “kilo-Watt” in MHPs and “Watt” in solar PV. In the recent period, AEPC scale-up its MG programmes, leading to the implementation of solar/wind MG systems and MHPs. However, it is seen that there is limited technical capacity to execute with a larger system extensively.

## VII. DISCUSSION AND THE WAY FORWARD

The MG is a concept that allows more customizable power delivery in the form of DER asset to the rural area. It is a grid line concept for parallel connections to the grid along with its supply as a back-up. The modern concept of MG uses multiple energy resources to maintain a balance in the supply-demand chain. For a reliable supply, the generation must meet with the demand, for which the MGs rely on different energy resources available within the local area. Since both of the generation and demand in DER-based system are periodic and unpredictable, problems like system instability and frequent interruption occur. Similarly, because of insufficient power at some instant of time (basically at peak demand period), the issues of low voltage, frequency fluctuation and even brownouts in the system occur. One of the major reason behind these problems is living habit of people from hilly and Himalayan area. The load factor of the isolated energy system in Nepal is very low, indicating the load demand during peak hour is very high and less energy consumption during the off-peak period. One of the important factors that must be considered during the discussion on Nepalese MGs is that most of the Nepalese MGs contain the MHPs, which generate constant power.

The most common technique that is used to maintain the grid functional during power deficit is load schedule. A specific portion of area or load used to be cut-off from the grid for a specific time and passing the power to another area and so on. In Nepalese MGs, a rolling blackout at the particular area is conducted by developing a load-shedding-table, or forcibly minimize the demand by instructing the consumer to use the electrical load under a limit (for example, people connected with the isolated MHPs can operate under 100 watt at peak period). As the significant demand usually is occurring at night, the generated energy during off-peak-period can be stored in ESS, and utilize at peak-demand-period or low-generation-hours for the regular operation. Further, the concept of Virtual Power Plant (VPP) and Block Chain can be introduced in the MGs that manages the whole system during system instability and recurring frequency interruption. However, the rating and coordination of the electrical components must be techno-economically optimized.

As not all DERs are designed to meet the required demand, DSM concept is introduced in most of the current MGs that keep the supply intact and utilize the limited sources to its fullest. During the outage, various MGs use DSM set-up



on the grid controller to maintain the supply-demand chain. Depending upon the requirement of users and/ or suppliers, the schemes are installed within the controller. For example, in one of the isolated MG system installed in Baidi, Tanahun, the system has offered three packages according to the consumer's demand: (i) light package "A", (ii) television package "B", and (iii) commercial package "C". Besides, a special package has been introduced in Nepalese MGs to those who cannot afford the price of electricity.

For the selection of the best strategy for a specific locality and special type of energy system, a depth understanding on characteristics of demand/ supply is most important. Forecasting profile of generation and load could help the operator to take an important decision for the balancing of demand/ supply chain, and minimize the consequences. The optimized model based on probabilistic approach for DSM, considering the stochastic nature of demand/ supply has been recommended by numerous study, which may be a practical and useful approach for a MG located at the remote area. The Stochastic Model Predictive Control (SMPC) method is generally used to evaluate the model within a MG control system. It is also useful to solve an online optimization problem that selects the best control action and drives the predicted output to the reference value. A cost function, along with the constraints as a design specification, can be developed to check the viability of the MG management strategy. By utilizing the recorded data, a controller can be operated for different control and management strategies such as DSM, SMPC, or even AI-based optimization to observe the load, generation and the system characteristics.

However, implementation of such an advanced concept may not be practical for the MGs located in remote areas. Some of the primary reasons behind these are expensive technology, lack of proper communication channels in remote areas, geographical difficulties etc. At current scenario, in most the Nepalese MGs, the operators at generation and load side are locally connected via some form of telecommunication medium, and all of the systems are controlled and managed by a controller or by the operators in manual mode. The MGs have different parameters to be controlled, which depend on the type of energy source, load types, grid codes and coordination grids, and many more. Because of the geographical difficulties and scattered nature of energy sources, the distributed control system is required in such MGs. Implementation of a fully centralized approach is infeasible in such cases because it requires extensive communication and computation.

For any electric system, once the line is connected, demand will keep increasing, although the generation is fixed. This may result in the unbalance demand/supply chain in the near future, followed by issues such as under-voltage, under-frequency, bidirectional power flow, instability, uncertainty, low inertia and even brownout. In most of the existed MGs, this problem had already occurred. Hence, future planning should be done during the design and implementation of the isolated energy system in such area, where regular

up-gradation is not possible. Further, it helps the operators and management committees to handle the system by adopting a practical strategy at the right time. Among numerous problem of MGs in Himalaya, the issues and actions on protection, regular maintenance, finance and functional management have important roles. One of the major foundations on long term operation of a system is proper operation and maintenance, without which no system will provide good outputs. It was mentioned in a study [97] that, the lifetime of a MG system can be increased by around two times by the proper maintenance. Hence the system must be regularly maintained and operated under specific rules and regulations for the sustainable operation.

### ACKNOWLEDGEMENT

The authors thank the Nepal Electricity Authority (NEA), the Alternative Energy Promotion Center (AEPC), and the Center for Electric Power Engineering (CEPE), Kathmandu University, to provide the requested information.

### ABBREVIATION

MG	Micro-grid
RES	Renewable Energy Source
MHP	Micro Hydropower Plant
SPV	Solar Photovoltaic
SAARC	South Asian Association for Regional Cooperation
AEPC	Alternative Energy Promotion Center
RERL	Renewable Energy for Rural Livelihood
SASEC	South Asia Sub-regional Economic Cooperation
RERA	Renewable Energy for Rural Area
MHIMG	Micro Hydro Interconnected MG
HAP	Household Air Pollution
RES	Renewable Energy Source
DG	Distributed Generator
GC	Generation Controller
ESS	Energy Storage System
LL	Local Load
MGCC	MG Central Control
DMS	Distribution Management System
EMS	Energy Management System
ELC	Electronic Load Controller
AVR	Automatic Voltage Regulator
PEC	Power Electronic Converter
BIL	Basic Insulation Level
MCCB	Module Case Circuit Breaker
SPD	Surge Protective Device
MOSA	Metal Oxide Surge Arrester
SPD	Surge Protective Device
MHFG	Micro Hydro Functional Group
MTF	Multi-Tier Framework
IPP	Independent Power Producer
PPA	Power Purchase Agreement

VPP	Virtual Power Plant
DER	Distributed Energy Resource
DSM	Demand Side Management
SMPC	Stochastic Model Predictive Control
AI	Artificial Intelligence
NEA	Nepal Electricity Authority
CEPE	Center for Electric Power Engineering

## REFERENCES

- [1] *Sustainable Energy for All (SE4ALL) Database From the SE4ALL Global Tracking Framework*, The World Bank, Washington, DC, USA, 2020.
- [2] *Settlement Size by Number of Households—Statistics of Nepal 2015*, Central Bureau of Statistics (CBS), Kathmandu, Nepal, 2015.
- [3] A. Shrestha, A. Singh, K. Khanal, and R. K. Maskey, "Potentiality of off-grid hybrid systems for sustainable power supply at kathmandu university campus," in *Proc. IEEE 6th Int. Conf. Power Syst. (ICPS)*, Mar. 2016, pp. 1–6.
- [4] B. Shakya, A. Bruce, and I. MacGill, "Survey based characterisation of energy services for improved design and operation of standalone micro-grids," *Renew. Sustain. Energy Rev.*, vol. 101, pp. 493–503, Mar. 2019.
- [5] B. Bhandari, K.-T. Lee, C. S. Lee, C.-K. Song, R. K. Maskey, and S.-H. Ahn, "A novel off-grid hybrid power system comprised of solar photovoltaic, wind, and hydro energy sources," *Appl. Energy*, vol. 133, pp. 236–242, Nov. 2014.
- [6] B. Bhandari, K.-T. Lee, W.-S. Chu, C. S. Lee, C.-K. Song, P. Bhandari, and S.-H. Ahn, "Socio-economic impact of renewable energy-based power system in mountainous villages of nepal," *Int. J. Precis. Eng. Manuf.-Green Technol.*, vol. 4, no. 1, pp. 37–44, Jan. 2017.
- [7] A. Shrestha, L. B. Rana, A. Singh, S. Phuyal, A. Ghimire, R. Giri, R. Kattel, K. Karki, and S. K. Jha, "Assessment of electricity excess in an isolated hybrid energy system: A case study of a Dangiwada village in rural Nepal," *Energy Procedia*, vol. 160, pp. 76–83, 2019.
- [8] S. Sah, A. Shrestha, and A. Papadakis, "Cost-effective and reliable energy system for Kathmandu University complex," in *Proc. 11th Int. Conf. Deregulated Eng. Market Issues*, Nicosia, Cyprus, 2018, pp. 20–21.
- [9] P. Shrestha, A. Shrestha, and B. Adhikary, "Comparative analysis of grid integration on distributed energy system," in *Proc. 5th Int. Conf. Develop. Renew. Energy Technol.*, Kathmandu, Nepal, 2018, pp. 29–31.
- [10] A. Shrestha, R. Kattel, M. Dachhepatic, B. Mali, R. Thapa, A. Singh, D. Bista, B. Adhikary, A. Papadakis, and R. K. Maskey, "Comparative study of different approaches for islanding detection of distributed generation systems," *Appl. Syst. Innov.*, vol. 2, no. 3, p. 25, Jul. 2019.
- [11] P. Kumar, T. Yamashita, A. Karki, S. Rajshekar, A. Shrestha, and A. Yadav, "Nepal-Scaling up electricity access through mini and micro hydropower applications: A strategic stock-taking and developing a future roadmap," World Bank, Washington, DC, USA, Tech. Rep., 2015.
- [12] A. Hirsch, Y. Parag, and J. Guerrero, "Microgrids: A review of technologies, key drivers, and outstanding issues," *Renew. Sustain. Energy Rev.*, vol. 90, pp. 402–411, Jul. 2018.
- [13] A. Chauhan and R. P. Saini, "Techno-economic optimization based approach for energy management of a stand-alone integrated renewable energy system for remote areas of india," *Energy*, vol. 94, pp. 138–156, Jan. 2016.
- [14] A. S. Aziz, M. F. N. Tajuddin, M. R. Adzman, M. A. M. Ramli, and S. Mekhilef, "Energy management and optimization of a PV/diesel/battery hybrid energy system using a combined dispatch strategy," *Sustainability*, vol. 11, no. 3, p. 683, 2019.
- [15] P. Shrestha, A. Shrestha, N. T. Shrestha, A. Papadakis, and R. K. Maskey, "Assessment on scaling-up of mini-grid initiative: Case study of mini-grid in rural nepal," in *Proc. Int. J. Precis. Eng. Manuf.-Green Technol.*, Feb. 2020, pp. 1–15.
- [16] P. A. Owusu and S. Asumadu-Sarkodie, "A review of renewable energy sources, sustainability issues and climate change mitigation," *Cogent Eng.*, vol. 3, no. 1, Apr. 2016, Art. no. 1167990.
- [17] R. Poudyal, P. Loskot, R. Nepal, R. Parajuli, and S. K. Khadka, "Mitigating the current energy crisis in nepal with renewable energy sources," *Renew. Sustain. Energy Rev.*, vol. 116, Dec. 2019, Art. no. 109388.
- [18] *Multi-Tier Framework for Measuring Energy Access Household Survey (MTF) 2017*, Energy Sector Management Assistance Program (ESMAP), World Bank, Nepal, South. Asia, 2017.
- [19] S. Ahmadzai and A. McKinna, "Afghanistan electrical energy and trans-boundary water systems analyses: Challenges and opportunities," *Energy Rep.*, vol. 4, pp. 435–469, Nov. 2018.
- [20] H. Kobayashi, J. Acharya, H. Zhang, and P. Manandhar, "Nepal energy sector assessment, strategy, and road map," *Asian Develop. Bank*, vol. 6, Jun. 2017.
- [21] D. Akinyele, J. Belikov, and Y. Levron, "Challenges of microgrids in remote communities: A STEEP model application," *Energies*, vol. 11, no. 2, p. 432, 2018.
- [22] S. C. Bhattacharyya and D. Palit, "Mini-grid based off-grid electrification to enhance electricity access in developing countries: What policies may be required?" *Energy Policy*, vol. 94, pp. 166–178, Jul. 2016.
- [23] R. Bhandari, L. G. Saptalena, and W. Kusch, "Sustainability assessment of a micro hydropower plant in nepal," *Energy, Sustainability Soc.*, vol. 8, no. 1, p. 3, Dec. 2018.
- [24] J. Butchers, S. Williamson, J. Booker, A. Tran, P. B. Karki, and B. Gautam, "Understanding sustainable operation of micro-hydropower: A field study in nepal," *Energy Sustain. Develop.*, vol. 57, pp. 12–21, Aug. 2020.
- [25] B. Shakya, "Mini grid development in nepal: An experience from RERL," in *Proc. Workshop Experience Sharing Mini Grid and Biomass Gasification*, 2012, p. 5.
- [26] *Progress at a Glance: A Year in Review*, Government of Nepal, Kathmandu, South Asia, 2019.
- [27] AEP. *Mission, Vision and Strategy*. Accessed: Dec. 12, 2020. [Online]. Available: <https://www.aepc.gov.np/mission-vision-and-strategy>
- [28] K. R. Adhikari, S. Gurung, and B. K. Bhattacharai, "Solar energy potential in nepal and global context," *J. Inst. Eng.*, vol. 9, no. 1, pp. 95–106, Jun. 2014.
- [29] AEP. *Minigrid projects*. Accessed: Mar. 26, 2020. [Online]. Available: <https://www.aepc.gov.np/>
- [30] AEP. (2018). *Environmental and Social Management Framework for Nepal: Private Sector-led Mini-grid Energy Access Project*. [Online]. Available: <https://www.aepc.gov.np/uploads/docs/final-esmf-nepal-minigrid-project-1545296018.pdf>
- [31] *Annual Progress Report 2018*, Ministry of Energy, Water Resources and Irrigation, Government of Nepal, Kathmandu, South Asia, 2018.
- [32] *Annual Progress Report 2017*, Ministry of Energy, Water Resources and Irrigation, Government of Nepal, Kathmandu, South Asia, 2017.
- [33] *Annual Progress Report 2016*, Ministry of Energy, Water Resources and Irrigation, Government of Nepal, Kathmandu, South Asia, 2016.
- [34] *Annual Progress Report 2015*, Ministry of Energy, Water Resources and Irrigation, Government of Nepal, Kathmandu, South Asia, 2015.
- [35] Gham Power Pvt. *Microgrids*. Accessed: Feb. 13, 2020. [Online]. Available: <https://ghampower.com/product/microgrids/>
- [36] S. K. Jha, P. Stoa, and K. Uhlen, "Socio-economic impact of a rural microgrid," in *Proc. 4th Int. Conf. Develop. Renew. Energy Technol. (ICDRET)*, Jan. 2016, pp. 1–4.
- [37] A. Shrestha, R. Bishwokarma, A. Chapagain, S. Banjara, S. Aryal, B. Mali, R. Thapa, D. Bista, B. P. Hayes, A. Papadakis, and P. Korba, "Peer-to-Peer energy trading in Micro/Mini-grids for local energy communities: A review and case study of nepal," *IEEE Access*, vol. 7, pp. 131911–131928, 2019.
- [38] Microgrid Project. *Indian Microgrids*. Accessed: Mar. 26, 2020. [Online]. Available: <http://microgridprojects.com/india-microgrids/>
- [39] L. Francklyn. *India's Microgrid Market: Ready for Takeoff*. Accessed: Mar. 26, 2020. [Online]. Available: <https://microgridnews.com/indias-microgrid-market-ready-for-takeoff/>
- [40] M. Fowlie, Y. Khaitan, C. Wolfram, and D. Wolfson, "Solar microgrids and remote energy access: How weak incentives can undermine smart technology," Tech. Rep., 2018.
- [41] (2020). *MINIGRIDS (India) Current Challenges and Future Strategies*. [Online]. Available: [https://www.selcofoundation.org/wp-content/uploads/2017/04/IAP\\_MinigridsIndiaReportTATA\\_Huda.pdf](https://www.selcofoundation.org/wp-content/uploads/2017/04/IAP_MinigridsIndiaReportTATA_Huda.pdf)
- [42] B. Bala and S. A. Siddique, "Optimal design of a PV-diesel hybrid system for electrification of an isolated island—Sandwip in bangladesh using genetic algorithm," *Energy for Sustain. Develop.*, vol. 13, no. 3, pp. 137–142, Sep. 2009.
- [43] *Mini Grids In Bangladesh : A Case Study of an Incipient Market*, World Bank, Washington, DC, USA, 2017, [Online]. Available: <http://documents.worldbank.org/curated/en/669331512390210193/pdf/ESM-aBangladeshCountryCaseStudy-PUBLIC.pdf>
- [44] *Power for Off-Grid Areas: Solar Mini-Grids Set Up in Two Districts of K-P*, The Exp. Tribune, Pakistan, South Asia, Jul. 2018.

- [45] H. A. Khan, H. F. Ahmad, M. Nasir, M. F. Nadeem, and N. A. Zaffar, "Decentralised electric power delivery for rural electrification in Pakistan," *Energy Policy*, vol. 120, pp. 312–323, Sep. 2018.
- [46] Renewables Readiness Assessment Pakistan. (2018). *International Renewable Energy Agency*. [Online]. Available: [https://www.irena.org/-/media/Files/IRENA/Agency/Publication/2018/Apr/IRENA\\_RRA\\_Pakistan\\_2018.pdf](https://www.irena.org/-/media/Files/IRENA/Agency/Publication/2018/Apr/IRENA_RRA_Pakistan_2018.pdf)
- [47] H. Samad and F. Zhang, *Electrification and Household Welfare: Evidence from Pakistan*. Washington, DC, USA: World Bank, 2018.
- [48] E. M. Mackres and D. Q. Anila, *Bhutan has achieved 100% Electricity Access. Here's how*. Accessed: Mar. 28, 2020. [Online]. Available: <https://www.weforum.org/agenda/2019/02/in-afghanistan-bhutan-and-nepal-off-grid-renewables-bring-power-to-remote-villages>
- [49] (2018). *Afghanistan Renewable Energy Development Issues and Options*. [Online]. Available: <http://documents.worldbank.org/curated/en/352991530527393098/pdf/Afghanistan-Renewable-Energy-Development-Issues-and-Options.pdf>
- [50] T. Dorji, T. Urmee, and P. Jennings, "Options for off-grid electrification in the Kingdom of Bhutan," *Renew. Energy*, vol. 45, pp. 51–58, Oct. 2012.
- [51] E. Litgow, "The impacts of rural electrification in the Kingdom of Bhutan," M.S. thesis, Nicolas School Environ., Duke University, Durham, NC, USA, 2017.
- [52] (2019). *Sri Lanka: Energy Sector Assessment, Strategy, and Road Map*. Accessed: Mar. 27 2019. [Online]. Available: <http://dx.doi.org/10.22617/TCS190557-2>
- [53] B. Tenenbaum, C. Greacen, and D. Vaghela, *Mini-Grids and Arrival of the Main Grid: Lessons from Cambodia, Sri Lanka, and Indonesia*. Washington, DC, USA: World Bank, 2018.
- [54] P. Tharakan, "Off-grid renewable energy program in myanmar," Asian Development Bank, Mandaluyong, Philippines, Tech. Rep., 2015.
- [55] T. S. Tran, D. T. Nguyen, and G. Fujita, "The analysis of technical trend in islanding operation, harmonic distortion, stabilizing frequency, and voltage of Isolated Entities," *Resources*, vol. 8, no. 1, p. 14, 2019.
- [56] M. Shumais and I. Mohamed. (2019). *Dimensions of Energy Insecurity on Small Islands: The Case of the Maldives*. [Online]. Available: <https://www.adb.org/publications/dimensions-energy-insecurity-small-islands-case-maldives>
- [57] T. Y. Jung and D. Kim, "A solar energy system with energy storage system for Kandooma Island, Maldives," *Korean Energy Econ. Rev.*, vol. 16, no. 2, pp. 33–56, 2017.
- [58] B. Shakya, A. Bruce, and I. MacGill, "Micro hydro interconnected mini grids in Nepal: Potential and pitfalls," in *Proc. Asia Pacific Solar Res. Conf.*, Brisbane, Queensland, 2015, pp. 1–4.
- [59] AEPC/RERL. (2013). *Techno-Socio-Economic Study of Baglung Mini Grid*. [Online]. Available: <https://www.aepc.gov.np/uploads/docs/2018-07-09>
- [60] AEPC. *Completed Activity of Mini Hydro and Min Grid*. Accessed: Jan. 29, 2020. [Online]. Available: <https://www.aepc.gov.np/sasec/activity?show=completed>
- [61] S. Rai, *Presentation on Introduction to RE Mini Grid Project Nepal*. New Delhi, India: AEPC, 2019.
- [62] M. Aryal, "Solar and wind energy project lights up four villages in Palpa," in *The Kathmandu Post*. Kathmandu, South Asia: Nepal, 2019.
- [63] G. Pepermans, J. Driesen, D. Haeseldonckx, R. Belmans, and W. D'haeseleer, "Distributed generation: Definition, benefits and issues," *Energy Policy*, vol. 33, no. 6, pp. 787–798, 2005.
- [64] M. A. Pedrasa and T. Spooner, "A survey of techniques used to control microgrid generation and storage during island operation," in *Proc. Australas. Universities Power Eng. Conf.*, 2006, pp. 1–6.
- [65] Z. A. Arfeen, A. B. Khairuddin, R. M. Larik, and M. S. Saeed, "Control of distributed generation systems for microgrid applications: A technological review," *Int. Trans. Electr. Energy Syst.*, vol. 29, no. 9, Sep. 2019, Art. no. e12072.
- [66] D. E. Olivares, A. Mehrizi-Sani, A. H. Etemadi, C. A. Cañizares, R. Iravani, M. Kazerani, A. H. Hajimiragha, O. Gomis-Bellmunt, M. Saeedifard, R. Palma-Behnke, G. A. Jiménez-Estévez, and N. D. Hatziaargyriou, "Trends in microgrid control," *IEEE Trans. Smart Grid*, vol. 5, no. 4, pp. 1905–1919, Jul. 2014.
- [67] L. Fushen, L. Ruisheng, and Z. Fengquan, *Microgrid Technology and Engineering Application*. Amsterdam, The Netherlands: Elsevier, 2015.
- [68] A. G. Tsikalakis and N. D. Hatziaargyriou, "Centralized control for optimizing microgrids operation," in *Proc. IEEE Power Energy Soc. Gen. Meeting*, Jul. 2011, pp. 1–8.
- [69] M. H. Cintuglu and O. A. Mohammed, "Multiagent-based decentralized operation of microgrids considering data interoperability," in *Proc. IEEE Int. Conf. Smart Grid Commun. (SmartGridComm)*, Nov. 2015, pp. 404–409.
- [70] M. Ilic-Spong, J. Christensen, and K. L. Eichorn, "Secondary voltage control using pilot point information," *IEEE Trans. Power Syst.*, vol. 3, no. 2, pp. 660–668, May 1988.
- [71] M. S. Mahmoud, "Microgrid control problems and related issues," in *Microgrid*. Amsterdam, The Netherlands: Elsevier, 2017, pp. 1–42.
- [72] N. D. Hatziaargyriou, N. Jenkins, G. Strbac, J. A. P. Lopes, J. Ruela, A. Engler, J. Oyarzabal, G. Kariniotakis, and A. Amorim, "Microgrids-large scale integration of microgeneration to low voltage grids," *Conseil Int. des Grands Réseaux Electriques*, Paris, France, Tech. Rep., 2006.
- [73] A. Mehrizi-Sani, "Distributed control techniques in microgrids," in *Microgrid*. Amsterdam, The Netherlands: Elsevier, 2017, pp. 43–62.
- [74] M. Yazdani and A. Mehrizi-Sani, "Distributed control techniques in microgrids," *IEEE Trans. Smart Grid*, vol. 5, no. 6, pp. 2901–2909, Nov. 2014.
- [75] AEPC. (2019). *Grid Interconnection of Micro-hydro Projects (MHPs) in Nepal*. [Online]. Available: [https://energypedia.info/wiki/Grid\\_Interconnection\\_of\\_Micro-hydro\\_Projects\\_\(MHPs\)\\_in\\_Nepal](https://energypedia.info/wiki/Grid_Interconnection_of_Micro-hydro_Projects_(MHPs)_in_Nepal)
- [76] Gham Power Pvt. *Solar Energy to Make Rural Electrification a Reality*. Accessed: Feb. 2, 2020. [Online]. Available: <https://ghampower.com>
- [77] S. Koirala and N. Bhattarai, "Control strategy and operation of renewable energy resources based microGrid: A case study of Chisapani, Nepal," *Tech. Rep.*, 2018.
- [78] N. Khadka, *Lightning Statistics in Nepal*. Sunny Maharjan, 2019.
- [79] N. P. Chaudhary, "Power system protection assessment of a community based mini-grid in baglung district of nepal," M.S. thesis Dept. Elect. Electron. Eng., Kathmandu Univ., Dhulikhel, Nepal, 2013.
- [80] N. Menemenlis, M. Ene, J. Belanger, G. Sybille, and L. Snider, "Metal oxide surge arresters on AC systems," *Tech. Rep.*, 1990.
- [81] G. D. McCann, E. Beck, and L. A. Finzi, "Lightning protection for rotating machines," *Trans. Amer. Inst. Electr. Eng.*, vol. 63, no. 6, pp. 319–333, Jun. 1944.
- [82] N. I. Ahmad, M. Z. A. Ab-Kadir, M. Izadi, N. Azis, M. A. M. Radzi, N. H. Zaini, and M. S. M. Nasir, "Lightning protection on photovoltaic systems: A review on current and recommended practices," *Renew. Sustain. Energy Rev.*, vol. 82, pp. 1611–1619, Feb. 2018.
- [83] *Protection Against Lightning—Part 1: General Principles*, document IEC 62305-1, 2010.
- [84] *Protection Against Lightning—Part 2: Risk Management*, document IEC 62305-2, 2010.
- [85] *Protection Against Lightning—Part 3: Physical Damage To Structures and Life Hazard*, document IEC 62305-3, 2010.
- [86] *Protection Against Lightning—Part 4: Electrical and Electronic Systems Within Structures*, document IEC 62305-4, 2010.
- [87] P. Barker, "Overvoltage considerations in applying distributed resources on power systems," in *IEEE Power Eng. Soc. Summer Meeting*, vol. 1, May 2002, pp. 109–114.
- [88] L. W. M. M. H. Rademakers Braam, S. G. M. Ramakers, H. R. A. Wessels, R. K. N. J. Prins, R. Lok, and L. Leunis, "Lightning damages of OWECSPart 1: Parameters relevant for costs modelling," *Petten*, vol. 1, p. 60, Jun. 2002.
- [89] V. Peesapati, I. Cotton, T. Sorensen, T. Krogh, and N. Kokkinos, "Lightning protection of wind turbines—a comparison of measured data with required protection levels," *IET Renew. Power Gener.*, vol. 5, no. 1, pp. 48–57, 2011.
- [90] *Wind Turbine Generator Systems—Part 24: Lightning Protection For Wind Turbines*, 2000.
- [91] C. W. Plummer, G. L. Goedde, E. L. Pettit, J. S. Godbee, and M. G. Hennessey, "Reduction in distribution transformer failure rates and nuisance outages using improved lightning protection concepts," *IEEE Trans. Power Del.*, vol. 10, no. 2, pp. 768–777, Apr. 1995.
- [92] F. Mahmood, M. E. M. Rizk, and M. Lehtonen, "Risk-based insulation coordination studies for protection of medium-voltage overhead lines against lightning-induced overvoltages," *Electr. Eng.*, vol. 101, no. 2, pp. 311–320, Jun. 2019.
- [93] C. Li, J. He, Z. Yu, Z. Yuan, S. Wang, J. Hu, R. Zeng, and S. Chen, "Effective protection distances of SPDs for household electrical appliances," *IEEE Trans. Electromagn. Compat.*, vol. 53, no. 3, pp. 690–699, Aug. 2011.



- [94] ESMAP. (2000). *Mini-Grid Design Manual, Energy Sector Management Assistance Program*. [Online]. Available: <https://www.esmap.org/node/1009>
- [95] R. B. Carpenter, Jr., and J. A. Lanzoni, *Designing for a Low Resistance Earth Interface (Grounding)*. Faridabad, Haryana: LEC, 2007.
- [96] E. Schmutzter and S. Pack, "New Ways to integrate grounding, equipotential bonding, shielding and lightning protection," Proceedings 19th International Expert Meeting, Power Engineering/Komunalna Energetika, Maribor, Slovenia, 2010.
- [97] S. Rolland and G. Glania, "Hybrid mini-grids for rural electrification: Lessons learned," Alliance for Rural Electrification, Brussels, Belgium, Tech. Rep., 2014.
- [98] *Mini/Micro Hydro Technology*. Government of Nepal, Kathmandu, South Asia. Accessed: Dec. 14, 2019. [Online]. Available: [http://www.aepc.gov.np/?option=renewable&page=subrenewable&mid=2&sub\\_id=14&id=4](http://www.aepc.gov.np/?option=renewable&page=subrenewable&mid=2&sub_id=14&id=4)
- [99] *Mission, Vision and Strategy*. Government of Nepal, Kathmandu, South Asia. Accessed: Jan. 12, 2020. [Online]. Available: <https://www.aepc.gov.np/mission-vision-and-strategy>
- [100] *Impact Study of Community Electrification*, Government of Nepal, Kathmandu, South Asia, 2017.



**ASHISH SHRESTHA** (Member, IEEE) received the bachelor's degree in electrical and electronics engineering from the School of Engineering, Pokhara University, Nepal, in 2014, the master's degree in planning and operation of energy system from the School of Engineering, Kathmandu University, Nepal, in 2017, and the Erasmus Mundus degree from the Department of Electrical Engineering, Frederick University, Cyprus, funded by the European Union. He is currently working as

a Lecturer with the Department of Electrical and Electronics Engineering, Kathmandu University, Nepal. He is also a Researcher (Activity Leader) with the Center for Electric Power Engineering (CEPE), Kathmandu University, Nepal. He is also involved in the problem-based-learning project funded by Erasmus+ Program of EU. He is also serving as a Co-Principal Investigator in a project funded by the Ministry of Foreign Affairs (MFA), Norway. He has published around 22 peer-reviewed journal articles and international conference papers. His research interests include power systems, distributed generation resources, planning and operation of energy systems, and electric vehicle. He is a Professional Member of the IEEE and the Nepal Engineering Association. He was assigned as a Reviewer for numerous international conferences and peer-reviewed journals from the IEEE, Springer, Elsevier, and so on.



**YAJU RAJBHANDARI** received the Erasmus Mundus degree from the Department of Electrical Engineering, Frederick University, Cyprus, in 2016, and the bachelor's degree in electrical and electronics engineering specialization in power and control from Kathmandu University, in 2018, where he is currently pursuing the M.S. degree in microgrid control and management. He is currently working as a Research Assistant with Kathmandu University. His employment experience

includes acting Plant Incharge in Panchakhanya Mai Hydropower Plant, Nepal. His research interests include control and management of microgrid, smart grid technology, and the IoT base automation.



**NASIB KHADKA** received the bachelor's degree in electrical and electronic engineering specialized in power and control from Kathmandu University, in 2018, where he is currently pursuing the M.S. degree in lightning protection of medium voltage distribution network with the Center for Electric Power Engineering (CEPE). He is also a Research Assistantship with the CEPE, Kathmandu University. His thesis focused on the elimination of soiling issues in solar photovoltaic power plants.

He has been working in solar photovoltaics, lightning protection system, mini-grid, high-voltage engineering. His research interests include smart grid technology, the Internet of Things, and machine learning applications. He received the Erasmus Mundus Leaders Grant for the Student Exchange Program hosted by Frederick University, Cyprus, in 2016.



**AAYUSH BISTA** received the Erasmus Mundus degree from the Department of Electrical Engineering, Frederick University, Cyprus, funded by the European Union, and the bachelor's degree in electrical and electronics engineering from the School of Engineering, Kathmandu University, Nepal, in 2018, where he is currently pursuing the master's degree in LED lighting. He is also working as a Research Assistant with the Center for Electric Power Engineering (CEPE), Kathmandu

University. His research interests include control and instrument systems, LED lighting, sensor technology, and renewable energies.



**ANUP MARAHATTA** received the bachelor's degree in electrical and electronics engineering from Kathmandu University, in 2019, where he is currently pursuing the M.S. degree with the Department of Electrical and Electronics Engineering. His bachelors' thesis was on the design and implementation of SCADA for dc micro-grid system. He is also a Research Assistant with the Department of Electrical and Electronics Engineering, Kathmandu University. His research

interests include power electronics, microgrid control systems, the Internet of Things, and robotics.

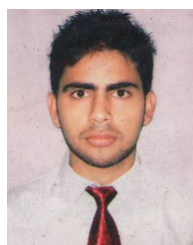

**ROJESH DAHAL** received the B.E. degree in electrical and electronics engineering in power and control from Kathmandu University, Nepal, in 2010, and the master's degree from Kathmandu University. He was a Research Assistant for Design and Development of Mini-Grid for Efficient use of Distributed Hydropower System funded project for a period of three years. He continued research for Droop-based controllers for Microhydro Plants for a period of two more years.

He worked as an Assistant Professor with the Nepal Engineering College, Nepal, for a period of three years. He is currently working as a Senior Electrical Engineer with Chilime Hydropower Company Ltd. His current research interests include mini-grid, renewable energy technology, and control systems design.





**JIWAN KUMAR MALLIK** received the degree in electrical engineering from the Institute of Engineering, Tribhuvan University, Nepal, in 2006, and the M.Tech. degree in power systems from IIT Delhi, in 2011. He is currently working as a Solar Power Expert with the Alternative Energy Promotion Center (AEPIC), Renewable Energy for Rural Livelihood (RERL), Nepal. He has over ten years of professional work experience which includes large scale solar PV and solar/wind

hybrid mini-grid, grid interconnection of renewable energy technologies, small hydropower projects of capacity up to 5MW, and energy efficiency. His research interests include power system dynamics and control, wider implementation of RE projects, advocacy for enabling environment of grid interconnected small scale RE projects, and energy financing.



**ANUP THAPA** (Member, IEEE) received the Ph.D. degree in computer engineering (with a concentration in wireless communication and networking) from Chosun University (alumni:whynet lab), Gwangju, South Korea, in 2013. He was working as a Postdoctoral Researcher with the UWB Wireless Communications Research Center, Department of Information and Communication, Inha University, Incheon, South Korea. He is currently an Active Researcher, with more than ten

years of research experience, in the field of wireless communication and networking. He is also working as an Assistant Professor with the Department of Electrical and Electronics Engineering, School of Engineering, Kathmandu University (KU), Nepal. His research interests include MAC layer protocol design for various wireless networking technologies, including WMAN, WLAN, WPAN, and WBAN, self-organizing networks, femtocell deployed broadband access, multi-user MIMO systems, high-efficiency networks, and the Internet of Things.



**BARRY P. HAYES** (Senior Member, IEEE) received the B.Eng. degree in electrical engineering from University College Cork, Cork, Ireland, in 2005, the M.Eng. degree from the National University of Ireland, Maynooth, Ireland, in 2008, and the Ph.D. degree from The University of Edinburgh, Edinburgh, U.K., in 2013. From 2013 to 2016, he was a Marie Skłodowska-Curie Postdoctoral Research Fellow with the IMDEA Energy Institute, Madrid, Spain. From 2016 to 2018,

he worked as a Lecturer (Assistant Professor) with the National University of Ireland Galway, Galway, Ireland. He was a Visiting Researcher with National Grid, U.K., and the University of Tennessee, Knoxville, TN, USA. He is currently a Lecturer (Assistant Professor) of electrical power systems with University College Cork. His research interests include network integration of renewable energy sources, and operation and planning of future power systems.



**PETR KORBA** (Senior Member, IEEE) received the Dipl.-Ing. degree in electrical engineering from Czech Technical University, Prague, Czech Republic, in 1995, and the Dr.-Ing. degree from the University of Duisburg, Germany, in 1999. He was a Member of Academic Staff with the Institute of Science and Technology, The University of Manchester, in 2001. He joined ABB Switzerland Ltd. He held different positions in the business unit power system automation. He worked as a

Principal Scientist with ABB Corporate Research Ltd., for more than ten years. Since 2008, he has been a Lecturer with ETH Zurich. He was a Professor of electric power systems with the Zurich University of Applied Sciences, in 2012, where he is currently the Head of the Electric Power Systems Group and the Deputy Head of the Institute of Energy Systems and Fluid Engineering. He is also the Co-Director of the Swiss Competence Centre of Energy Research (SCCER, Grids and Components).



**FRANCISCO M. GONZALEZ LONGATT** (Senior Member, IEEE) is currently a Full Professor of electrical power engineering with the Institutt for elektro, IT og kybernetikk, Universitetet i Sørøst-Norge, Norway. He is the author or editor of several books (Spanish and English). He has prolific research productivity, including several industrial research projects and consultancy worldwide. His research interest includes innovative (operation/control) schemes to optimize the performance

of future energy systems. He is a member of The Institution of Engineering and Technology - The IET, U.K., and the International Council on Large Electric Systems - CIGRE. He received the Professional Recognition as the Fellow of the Higher Education Academy (FHEA), in January 2014. He is the Vice-President of the Venezuelan Wind Energy Association. He is also an associate editor in several journals with an impressive track record on scientific publications.

• • •