

# A new DC corrective OPF based on generator and branch outages modelled as fictitious nodal injections

Pedro J. Martínez-Lacañina<sup>1</sup>, José L. Martínez-Ramos<sup>2</sup>, Antonio de la Villa-Jaén<sup>3</sup>, and Alejandro Marano-Marcolini<sup>4</sup>

*Department of Electrical Engineering (University of Seville)*

*Escuela Técnica Superior de Ingeniería, Camino de los Descubrimientos, 41092 - Sevilla (Spain)*

*e-mail<sup>1</sup> (corresponding author): pedroj@us.es, e-mail<sup>2</sup>: jlmr@esi.us.es, e-mail<sup>3</sup>: adelavilla@us.es, e-mail<sup>4</sup>: alejandromm@us.es*

## Abstract

This work deals with a new formulation for the direct current corrective optimal power flow. The formulation is based on the outage of generators and/or branches modelled as fictitious injections of active power. By including that fictitious injections in the optimization problem, the injections are adjusted to the post-contingency state as a consequence of the corrective actions carried out to bring the system back to its normal state. So, when the analysis of contingencies is performed, the classical topological analysis and the subsequent analyses are avoided with this approach. This new formulation uses the sensitivity matrix between branch power flows and powers injected in a power system. An important feature of this matrix is to remain constant during the Contingency Analysis performed for the generation-load scenario (base case) of each period of time to be analysed. The approach proposed is illustrated in the IEEE-RTS of 24 buses. The results obtained in this distribution network demonstrate that the proposed methodology can assess the impact of contingencies with an acceptable accuracy and a short computation time.

**Key words:** Contingency Analysis, DCOPF, sensitivity matrix, fictitious injections.

## I. INTRODUCTION

With the opening of the national electricity markets to international competition and the requirement of the open transmission access, load flow is the basic building block for the management of large, interconnected, multinational transmission systems [1] [2] [3] [4]. Recently, linear power flow models - Direct Current network analysis (DC analysis) - are in widespread and even increasing use, particularly in congestion-constrained market applications. As examples, congestion management of the ISO-NE (Independent System Operator - New England) was based on the use of direct current formulations [5] [6], and linear methods remain the primary tool for estimating the impact of an outage in many security analysis programmes [7] [8] [9].

DC load flow models are inherently approximate, and it is well-known that their accuracies are very close to the system and case dependent. When they are applied to Contingency Analysis, these linear methods approximate the full nonlinear power-flow solution to produce the long-term steady-state conditions after an outage, and they are used primarily to verify that thermal line limits are not exceeded after the outage [10] [11].

This work focuses on the analysis of the impact of potential outages in electric networks and covers direct current modelling for its application in a corrective Optimal Power Flow (OPF), aiming to exploit the capabilities of the linear methods and improve the analysis techniques of energy systems.

For instance, it deals with a more simple and faster analysis than the performed by the current DC load flow based methods and its simplifications associated with test cases in Contingency Analysis [12] [13] [14] [15] [16].

The main novelty of the formulation proposed - DC Corrective Optimal Power Flow, called hereafter DC-COPF - is the fact that the contingency due to generator and/or branch outages (line or transformer) is managed as fictitious injections of

active power. These fictitious injections are formulated by means of their corresponding elements in the matrix of sensitivities between the branch power flows and the powers injected in an electric power system. The inclusion of the contingency (single or multiple) as fictitious nodal injections in the optimization problem implies that the fictitious injections are adapted to the post-contingency state by changing the optimization decision variables. At this stage, it is important to note that the new DC-COPF proposed in this paper includes the outage of generators - modelled as fictitious active power injections - in addition to the previous formulation of the optimization problem [17] where only the outage of branches were included.

An important aspect is that the sensitivity matrix is constant in the load scenario of each period of time to be analysed. Therefore, with the formulation proposed, there is no need to use the conventional Power Transfer Distribution Factors (PTDFs) and, consequently, the use of Topological Analysis and Direct Current Load Flow (DCLF) in the post-contingency state [14] [18] [19] [20] [21] [22] [23].

In this paper, various comparative studies are also presented to illustrate how our methodology proposed can be used to assess the post-contingency state in Contingency Analysis. In these studies, the procedure proposed is applied to the 24 buses network of the well-known IEEE-RTS [24]. The errors associated with the methodology proposed are presented for this network, and these show accurate results in both planning and 24 hours-ahead security assessment.

The paper is arranged as follows. First, the basic concepts of the DC network analysis are set out. Second, the mathematical problem and the formulation proposed of the optimization algorithm are presented, followed by the numerical simulations and the subsequent analysis of the results. Finally, some conclusions derived from this work are summarized.

## II. SENSITIVITY MATRIX, BRANCH POWER FLOWS AND NODAL POWERS INJECTED

DC load flow is based on the assumption that  $V_i = 1$  at all buses, losing in this way the capability to track reactive power flows or any other voltage related data. For resistance values much lower than reactance values of the branches of a power system, this analysis carries out accurate results for the active problem. Having ignored the branch resistances, the sum of all active powers is zero, which means that the slack power (or any other) is a linear combination of the remaining ones.

In this section the power system showed in Figure 1 is considered as a reference and is used in the following explanations.

### Fig. 1. Electric Power System in Normal State.

Considering the conventional DCLF (Direct Current Low Flow) [8] [9] [11] [13], then a linear relationship between the active power flows  $P_f$  and the active power injections  $P$  can be obtained for the power system, as follows:

$$P_f = [X^{-1} A^T B^{-1}] P = S_f P \quad (1)$$

where  $X$  expresses a diagonal matrix of branch reactances,  $A$  denotes the branch-to-node incidence matrix, reduced by removing the slack bus,  $B$  is a matrix (omitting the slack bus) defined as the matrix  $B'$  of the Fast Decoupled Load Flow, and  $S_f$  is the matrix of sensitivities between branch power flows and powers injected [11].

Since we are dealing with a linear system, the Superposition Principle can be applied, and power flows after a change on

the powers injected can be computed as:

$$P_f = S_f [P^0 + \Delta P] = P_f^0 + \Delta P_f \Rightarrow \Delta P_f = S_f \Delta P$$

where  $\Delta P_f$  is the vector of variations of branch power flows after a change  $\Delta P$  on the powers injected, and  $P_f^0$  is the vector of active power flows in the base case (base-point case).

In case of contingencies due to a line or transformer outage, post-contingency flows can be obtained using the Compensation Theorem for linear systems. In this way, flow changes due to the outage of the branch between nodes  $i$  and  $j$ , carrying an active power flow  $P_{ij}^0$  before the outage, are obtained as

$$\Delta P_f' = S_f' \Delta P_i$$

where  $\Delta P_i$  only contains the injections  $P_{ij}^0$  in node  $i$  and  $-P_{ij}^0$  in node  $j$ , and matrix  $S_f'$  is

$$S_f' = (X')^{-1} (A')^T (B')^{-1}$$

where  $X'$ ,  $A'$  and  $B'$  correspond to matrices with the same meaning as in equation (1), but they have to be calculated in the post-contingency state by elimination of the  $ij$  outaged branch.

In DC analysis, an usual procedure to perform Contingency Analysis is to use Power Transfer Distribution Factors (PTDFs) [8] [9] [11] [13] [23]. The above set out conventional procedure needs to perform a Topological Analysis and the subsequent analyses in the post-contingency state to obtain the PTDFs. Focused on avoiding the conventional procedure that implies refactorizing the matrix  $B$  to obtain the matrix  $S_f'$ , an alternative to using the Compensation Theorem to obtain the distribution factors is achieved by modelling the outage of the branch using two fictitious injections at both ends [11].

This issue has been considered in the formulation of the optimization problem proposed. So, the fictitious nodal injections that model the branch in a outaged state are obtained in the optimization algorithm from the  $S_f$  matrix, equation (1). In this way, the fictitious nodal injections modify their value in relation to the changes (corrective actions) performed by the optimization problem. Changes in the powers injected in the system nodes can be motivated by loss of generation, branch outages, load shedding or generation rescheduling [11] [25] [26] [27] [28].

The main novelty of this approach stems from the use in the optimization problem of the  $S_f$  matrix of sensitivities between branch power flows and powers injected, to model the fictitious injections. Notice that an important feature of the  $S_f$  matrix is to remain constant during the Contingency Analysis performed for the generation-load scenario (base case) of each period of time to be analysed [11] [14] [17] [19] [21] [29] [30].

### III. CONTINGENCIES MODELLED AS FICTITIOUS NODAL INJECTIONS OF ACTIVE POWER

In this section, it is set out how the loss of single or multiple elements of a power system is modelled by using fictitious injections of active power [11] [14] [17]. For simplicity, the power system showed in Figure 1 is used as a reference. In our analysis, this power system is assumed to be a lossless network.

### A. Single contingency: generator failure.

The generator outage (single contingency) is the easiest case to model by means of fictitious nodal injections of active power. Let us assume that the generator at node  $t$  (Figure 1) is the affected element in the single contingency. Figure 2 shows the post-contingency state.

#### Fig. 2. Generator out of service at node $t$ .

Assuming that the  $p_{gt}^0$  loss generation in node  $t$  is supported by the reference bus (slack) in the post-contingency state, then the  $\Delta p_{rs}$  active power flow increment in a  $rs$  branch in service (Figure 2) is:

$$p_{rs} = p_{rs}^0 + S_{rs,t} \Delta p_{gt} \Rightarrow \Delta p_{rs} = S_{rs,t} \Delta p_{gt}$$

where  $\Delta p_{gt} = -p_{gt}^0$  is the active power generation of generator at node  $t$  before the failure (pre-contingency state) of the mentioned generator  $t$ ,  $S_{rs,t}$  is the element of the sensitivity matrix that connects the active power flow in branch  $rs$  with the active power injection increment  $\Delta p_{gt}$  in node  $t$ , and, finally,  $p_{rs}$  and  $p_{rs}^0$  are the active power flow in branch  $rs$  in the post- and pre-contingency states, respectively.

### B. Single contingency: branch failure.

The presented formulation is based on modelling the outaged branch by using two fictitious injections at both ends of the failure branch. The single contingency considered in this point is the failure of the branch  $ij$  of the power system of Figure 1. The post-contingency state due to this failure is shown in Figure 3.

#### Fig. 3. Branch $ij$ out of service.

This approach is based on computing the fictitious injections by means of the  $S_f$  matrix of sensitivities between branch power flows and powers injected [11] [14] [17] [19] [21]. The main advantage corresponds to the fact that for each period of time to be assessed, the  $S_f$  matrix remains constant during the contingency analysis of the system.

When the contingency of branch  $ij$  is modelled by means of two active power injections  $\Delta p_i$  and  $\Delta p_j$  placed, respectively in the  $i$  and  $j$  nodes of the outaged branch (Figure 4), the condition to be verified is that the power balance in the  $i$  and  $j$  nodes must be in the post-contingency state the same that in the pre-contingency state.

#### Fig. 4. Branch $ij$ virtually in service. Failure modelled as two fictitious nodal injections.

Besides, by assuming that  $p_{ij}$  is the active power flow in branch  $ij$  in the post-contingency state, the failure of the branch  $ij$  can be modelled by means of two fictitious nodal injections  $\Delta p_i$  and  $\Delta p_j$ , when:

$$\Delta p_i = -\Delta p_j = p_{ij}$$

Let us assume that branch  $ij$  has an active power flow  $p_{ij}^0$  in the base case (pre-contingency state). In the post-contingency state (branch  $ij$  outage), by applying the Superposition Principle, the fictitious active power flow  $p_{ij}$  can be obtained as

follows,

$$p_{ij} = \left\{ p_{ij}^0 [1 - (S_{ij,i} - S_{ij,j})]^{-1} \right\} = \Delta p_i$$

where  $S_{ij,i}$  and  $S_{ij,j}$  are the sensitivities between the active power flow in the  $ij$  outaged branch, and the  $\Delta p_i$  and  $\Delta p_j$  are the fictitious injections of active power in nodes  $i$  and  $j$ , respectively, of the  $ij$  branch. Focusing on the sensitivities  $S_{ij,i}$  y  $S_{ij,j}$ , note that these sensitivities are elements of the  $S_f$  matrix, equation (1), and this matrix has been previously calculated in the pre-contingency state (Figure 1, base case).

As a consequence of the outage of the  $ij$  branch, the  $\Delta p_{rs}$  increment in the active power flow of the  $rs$  branch in service, is obtained as follows:

$$\Delta p_{rs} = p_{rs}^0 (S_{rs,i} - S_{rs,j}) [1 - (S_{ij,i} - S_{ij,j})]^{-1}$$

where  $p_{rs}^0$  is the active power flow in the  $rs$  branch in the pre-contingency state. The sensitivities  $S_{rs,i}$  and  $S_{rs,j}$  represent the relation between the active power flow in the  $rs$  branch and the changes in the active power injections in nodes  $i$  and  $j$ , respectively.

### C. Multiple contingency.

Figure 5 shows a multiple contingency due to the simultaneous failure of a generator and a branch in the power system (double contingency). The outaged generator is supposed to be placed at node  $t$  and the outaged branch is supposed to be placed from node  $i$  to node  $j$  (branch  $ij$ ).

For this double contingency, it is supposed that the generator placed at node  $t$  was generating  $p_{gt}^0$  (active power) and the active power flow in the branch  $ij$  was  $p_{ij}^0$ , both elements in the pre-contingency state. Also, it is supposed that the lost active power generation  $\Delta p_{gt} = -p_{gt}^0$  is assumed by the generator of the reference bus (slack).

#### Fig. 5. Generator at node $t$ and branch $ij$ simultaneous out of service.

From the conditions mentioned above, the active power flow  $p_{ij}$  in the branch  $ij$  (virtually in service) is:

$$\Delta p_i = [p_{ij}^0 + S_{ij,t} \Delta p_{gt}] [1 - (S_{ij,i} - S_{ij,j})]^{-1} \quad (2)$$

where  $\Delta p_i = -\Delta p_j = p_{ij}$  and  $\Delta p_{gt} = -p_{gt}^0$

In the post-contingency state (Figure 5), the active power flow in a  $rs$  branch in service is:

$$p_{rs} = p_{rs}^0 + S_{rs,i} \Delta p_i + S_{rs,j} \Delta p_j + S_{rs,t} \Delta p_{gt} \quad (3)$$

where  $p_{rs}$  and  $p_{rs}^0$  are the active power flows in the  $rs$  branch in the states post-contingency and pre-contingency, respectively.

Rearranging the terms of (3) and by applying (2), the  $\Delta p_{rs}$  variation of the active power flow in the  $rs$  branch is:

$$\Delta p_{rs} = S_{rs,t} \Delta p_{gt} + (S_{rs,i} - S_{rs,j}) [p_{ij}^0 + S_{ij,t} \Delta p_{gt}] [1 - (S_{ij,i} - S_{ij,j})]^{-1}$$

The formulation for the case of multiple contingency (simultaneous outages) of branches, Figure 6, is presented next.

**Fig. 6. Multiple contingency of branches modelled as fictitious nodal injections.**

Notice that considering the interactions between the simultaneous outages of branches, the injections at both ends of the outaged branches are computed by solving a linear system of equations. For the case of multiple contingency of branches, in the post-contingency state, the active power flow in any  $rs$  branch in service is:

$$\Delta p_{rs} = p_{rs}^0 + (S_{rs,a} - S_{rs,b}) p_{ab} + \dots + (S_{rs,i} - S_{rs,j}) p_{ij} + \dots$$

#### IV. DC CORRECTIVE OPF (DC-COPF): PROBLEM FORMULATION

The applied optimization problem is based on linear programming [11] [12] [15] [29] [31] [32] and is carried out to obtain remedial actions (generation re-dispatch and/or load shedding) to bring the system back to its normal state when a contingency occurs [11] [20] [26] [29] [31] [33]. The cost assigned to generation rescheduling is significantly lower than the cost of load shedding with the aim of minimizing the use of these measures. The formulation assumes that the loss of generation is supported by the reference bus (slack) in the post-contingency state, but other criterion that deals with the loss of generation by selected generators could be easily implemented in the proposed algorithm by making minor changes [34] [35] [36].

By considering the sensitivity matrix  $S_f$ , the OPF problem of active power dispatch based on fictitious active power injections and with limited number of corrective actions to face line and/or generator outages (single or multiple contingency), can be formulated as follows:

$$\min \sum_{g \in \mathcal{G}} c_{g,u} \Delta p_{g,u} + \sum_{g \in \mathcal{G}} c_{g,d} \Delta p_{g,d} + \sum_{l \in \mathcal{L}} c_{l,s} \Delta p_{l,s}$$

**subject to**

$$\begin{aligned} \sum_{g \in \mathcal{G}} (\Delta p_{g,u} - \Delta p_{g,d}) + \sum_{l \in \mathcal{L}} \Delta p_{l,s} + \sum_{gf \in \mathcal{G}^k} \Delta p_{gf}^k &= 0 \\ \Delta p_i^k &= -\Delta p_j^k, \Delta p_{gf}^k = -p_{gf}^0 \\ \Delta p_{g,u} &\leq (p_{g,u}^{max} - p_{g,u}^0), \Delta p_{g,d} \leq (p_{g,d}^0 - p_{g,d}^{min}), \Delta p_{l,s} \leq p_{l,s}^{max} \\ \Delta p_{g,u} &\geq 0, \Delta p_{g,d} \geq 0, \Delta p_{l,s} \geq 0 \\ \forall ij \in \mathcal{B}^k, \forall i, j \in \mathcal{N}, k \in \mathcal{C} \end{aligned}$$

#### Branches in service

$$\begin{aligned} -p_{rs}^{max} &\leq p_{rs}^0 + \sum_{g \rightarrow n} S_{rs,n} (\Delta p_{g,u} - \Delta p_{g,d}) + \sum_{l \rightarrow n} S_{rs,n} \Delta p_{l,s} \\ &+ \sum_{ij \in \mathcal{B}^k} (S_{rs,i} \Delta p_i^k + S_{rs,j} \Delta p_j^k) + \sum_{gf \rightarrow n} S_{rs,n} \Delta p_{gf}^k \leq p_{rs}^{max} \\ \forall rs \in \mathcal{B}, \forall rs \neq ij, \forall i, j, n, r, s \in \mathcal{N}, k \in \mathcal{C} \end{aligned}$$

### Branches virtually in service (outaged branches)

$$\begin{aligned}
p_{ab}^0 &= [1 - (S_{ab,a} - S_{ab,b})] \Delta p_a^k - \sum_{g \rightarrow n} S_{ab,n} (\Delta p_{g,u} - \Delta p_{g,d}) - \sum_{l \rightarrow n} S_{ab,n} \Delta p_{l,s} \\
&\quad - \sum_{ij \in \mathcal{B}^k} (S_{ab,i} \Delta p_i^k + S_{ab,j} \Delta p_j^k) - \sum_{gf \rightarrow n} S_{ab,n} \Delta p_{gf}^k \\
&\quad \forall ab \in \mathcal{B}^k, \forall ab \neq ij, \forall i, j, n, a, b \in \mathcal{N}, k \in \mathcal{C}
\end{aligned}$$

where,

- Superscript 0 (resp.  $k$ ) refers to the base case (resp. contingency  $k$  state).
- $\mathcal{C}$  is the set of contingencies postulated.
- $\mathcal{N}$  and  $\mathcal{L}$  are the set of nodes and the set of loads, respectively.
- $\mathcal{G}$  is the set of generators in service in the post-contingency state.
- $\mathcal{G}^k$  is the set of outaged generators, but virtually in service in the post-contingency state  $k$ .
- $\mathcal{B}$  is the set of branches in service in the post-contingency state.
- $\mathcal{B}^k$  is the set of outaged branches, but virtually in service in the post-contingency state  $k$ .
- $g \rightarrow n$  is the set of generators in service connected to node  $n$ .
- $gf \rightarrow n$  is the set of outaged generators connected to node  $n$ , but virtually in service in the post-contingency state.
- $l \rightarrow n$  is the set of loads (demands) connected to node  $n$  and affected by a load-shedding.
- $\Delta p_{gf}^k$  correspond to the vector of fictitious active power injections that model the outaged generators at contingency  $k$ .
- $\Delta p_i^k$  y  $\Delta p_j^k$  expresses the fictitious active power injections used for modelling the outage of the  $ij$  branch.
- $\Delta p_{g,u}$ ,  $\Delta p_{g,d}$ ,  $\Delta p_{l,s}$  correspond to generation control actions (up and down) and to load shedding, respectively, with  $c_{g,u}$ ,  $c_{g,d}$  y  $c_{l,s}$  being penalty indices, respectively, for active power cost of generator  $g$ , and load shedding  $l$ .

Note that fictitious injections,  $\Delta p_i^k$  and  $\Delta p_j^k$ , modelling outaged branches are also computed by the optimization formulation, as the power flows are affected by the control actions. Similarly, the power flows are affected in the branches in service, whether fictitious injections are modified as a consequence of corrective actions. Also, the elements of the  $S_f$  matrix of sensitivity depend only on the network topology at the pre-contingency state, and, consequently, they have been computed off-line, in a time before the post-contingency. Finally, it must be considered that the fictitious injections are linked to variations of power flows in the branches of the system and to the power-injection variations carried out by the corrective actions. Consequently, fictitious injections are adaptive injections to changes of power injections in the system.

## V. NUMERICAL SIMULATIONS AND RESULTS

The formulation proposed is handled by using the GAMS platform and the same software has been used to handle the formulation corresponding to the traditional DC network analysis applied in the simulations. The minimization problem has been solved using the CPLEX solver running under GAMS. CPLEX implements a dual simplex algorithm for solving the linear programming problem [37] [38]. All tests have been performed on a 2.01-GHz, 2-GB RAM, PC AMD-Athlon.

### A. Description of the test system of 24 buses

Representative numerical results obtained by applying the approach proposed in the IEEE-RTS of 24 buses [24] are presented in this section. A summary of the characteristics of this test system is given in Table I, where:  $\mathcal{N}$ ,  $\mathcal{G}$ ,  $\mathcal{D}$ ,  $\mathcal{B}$ ,  $\mathcal{L}$ ,  $\mathcal{T}$ , and  $\mathcal{S}$  denote the number of buses, generators, loads (demands), branches, lines, all transformers, and shunt elements, respectively.

TABLE I  
TEST SYSTEM SUMMARY

System	$\mathcal{N}$	$\mathcal{G}$	$\mathcal{D}$	$\mathcal{B}$	$\mathcal{L}$	$\mathcal{T}$	$\mathcal{S}$
IEEE-RTS	24	33	17	34	29	5	1

The load-generation scenario for the active problem and the rest of data of the IEEE-RTS have been obtained from reference [24]. The selected scenario (Base Case) corresponds to the 18 : 00 h of the Summer season and has been used as the pre-contingency state (N-0 Contingency Level). This scenario - for 100 MVA power base - is shown per unit (pu) in Table II including both 138 kV and 230 kV levels of the IEEE-RTS.

TABLE II  
GENERATION-LOAD SCENARIO: BASE CASE (N-0 CONTINGENCY LEVEL).

* 138 kV level										
BUS	01	02	03	04	05	06	07	08	09	10
Generation (pu)	1.87	1.87	—	—	—	—	2.86	—	—	—
Load (pu)	1.62	1.55	2.06	1.41	1.39	1.79	1.72	1.82	2.03	2.16

* 230 kV level										
BUS	13	14	15	16	18	19	20	21	22	23
Generation (pu)	5.18	—	2.15	1.55	3.90	—	—	3.90	3.00	6.45
Load (pu)	2.65	1.94	3.17	1.00	3.33	1.81	1.28	—	—	—

The key issue of this section is to present the approach proposed as an acceptable tool for the contingency analysis of transmission and sub-transmission systems. So test simulations have been performed for contingencies considering both transmission (230 kV level) and sub-transmission (138 kV level) systems of the IEEE-RTS.

Note that the DC network analysis is also acceptable in sub-transmission voltage levels, as far as the requirements for using this model are completed by subtransmission networks [8][9][11][21]. These requirements are satisfied by the 138 kV level of the IEEE-RTS (sub-transmission area).

### B. N-1 test case

The analysis of the outage of the line from BUS 07 to BUS 08 of the 138 kV sub-transmission area (IEEE-RTS) is shown in this point, as an example of the advantages of the procedure proposed (DC-COPF) versus the traditional DC network analysis based on a power flow. The pre-contingency state is shown in Figure 7(a).

The main importance of this single contingency is related to the fact that the BUS 07 is an isolated system in the post-contingency state. In the case of using a traditional network analysis, the priority is to perform the Topological Analysis right after the contingency, and, then, the rest of the conventional analysis.



The main novelty of the DC-COPF proposed stems from the fact that the above mentioned analyses are avoided. Note that the formulation proposed implements contingencies as fictitious injections of active power. Even more, this formulation implies that the outaged line (from BUS 07 to BUS 08) is considered as a line virtually in service.

Figure 7 shows how the DC-COPF proposed is performed to evaluate this single contingency. The post-contingency state is represented in Figure 7(b). Note that the line virtually in service is the dashed line:

- $p_{(07-08)}$  = fictitious-active power flow in the line from BUS 07 to BUS 08.
- $\Delta p_{(07,07-08)}$  = fictitious-active power injection in BUS 07 associated with the outage of the line from BUS 07 to BUS 08.
- $\Delta p_{(08,07-08)}$  = fictitious-active power injection in BUS 08 associated with the outage of the line from BUS 07 to BUS 08.

**Fig. 7. N-1 test case modelled as fictitious injections.**

By using the technique proposed the fictitious injections are directly obtained in the optimization problem. For this single contingency, the fictitious injections were fixed to the next:

$$\Delta p_{(07,07-08)} = -\Delta p_{(08,07-08)} = p_{(07-08)} = -1.13 \text{ pu}$$

and no cases were detected where any branch were overloaded and load-shedding wasn't necessary.

Finally, by the DC-COPF proposed a re-scheduling generation was carried out to reach a viable state for the system. So, the generation was adjusted to demand in BUS 07, Figure 7(b), and the rest of the re-scheduling generation is shown in Table III for all buses affected.

TABLE III  
CORRECTIVE ACTIONS: N-1 TEST CASE.

BUS	01	02	07	13	18	21	23
Generation-up (pu)	0.05	0.05	—	0.68	0.10	0.10	0.15
Generation-down (pu)	—	—	1.13	—	—	—	—

*C. N-2 test case*

As equal as in the previous point, the first case to show in this point is a contingency associated with an isolated zone. This contingency is related to the simultaneous outage of the lines from BUS 17 to BUS 22 and from from BUS 21 to BUS 22, both lines of the transmission area (230 kV) of the IEEE-RTS. The pre-contingency state is presented in Figure 8(a).

The post-contingency state is shown in Figure 8(b) as is modelled in the DC-COPF proposed. Note that BUS 22 is an isolated area in the post-contingency state and, consequently, a generation of 3.00 pu is out of service.

**Fig. 8. First N-2 test case modelled as fictitious injections.**

By applying the DC-COPF proposed to this N-2 contingency, no cases were detected where any branch were overloaded, but load-shedding was necessary. Equal results were obtained when the traditional DC network analysis was used to analyze this multiple contingency.

Notice that the DC-COPF proposed implements outaged lines as fictitious injections and, consequently, they are treated as lines virtually in service in the optimization problem. Also, it is important to note that the methodology proposed - by using fictitious injections of active power - carries out an accurate result without a previous Topological analysis and the rest of traditional consequent analyses.

The meaning of the terms in Figure 8(b) is:

- $p_{(17-22)}$  = fictitious-active power flow in the line from BUS 17 to BUS 22.
- $\Delta p_{(17,17-22)}$  = fictitious-active power injection in BUS 17 associated with the outage of the line from BUS 17 to BUS 22.
- $\Delta p_{(22,17-22)}$  = fictitious-active power injection in BUS 22 associated with the outage of the line from BUS 17 to BUS 22.
- $p_{(21-22)}$  = fictitious-active power flow in the line from BUS 21 to BUS 22.
- $\Delta p_{(21,21-22)}$  = fictitious-active power injection in BUS 21 associated with the outage of the line from BUS 21 to BUS 22.
- $\Delta p_{(22,21-22)}$  = fictitious-active power injection in BUS 22 associated with the outage of the line from BUS 21 to BUS 22.

For the fictitious injections the optimization problem carried out the following for the post-contingency state:

$$\Delta p_{(17,17-22)} = -\Delta p_{(22,17-22)} = p_{(17-22)} = -2.56 \text{ pu}$$

$$\Delta p_{(21,21-22)} = -\Delta p_{(22,21-22)} = p_{(21-22)} = -8.48 \text{ pu}$$

Obviously, when the N-2 contingency is analysed, corrective actions are taking into account by the DC-COPF proposed to bring back the rest of the system to normal state. These corrective actions are shown in Table IV.

TABLE IV  
CORRECTIVE ACTIONS: FIRST N-2 TEST CASE.

BUS	01	02	07	09	13	18	21	23
Generation-up (pu)	0.05	0.05	0.14	—	0.73	0.10	0.10	0.16
Load-shedding (pu)	1.61	—	—	0.06	—	—	—	—

Finally, the case associated with an N-2 contingency which implies an overloaded state is set out. This contingency considers the simultaneous outage of the lines from from BUS 12 to BUS 13 and from from BUS 12 to BUS 23, both lines of the transmission area (230 kV) of the IEEE-RTS. The pre-contingency state is shown in Figure 9(a).

When this contingency was simulated, Figure 9(b), two branches were detected in overloaded state. The first one, the transformer from BUS 10 to BUS 11 and, the second one, the line from BUS 11 to BUS 13. It is important to note that two transformers of 4.00 pu each one in BUS 12 are out of service as a consequence of this multiple contingency, Figure 9(b). These transformers interconnect the 230 kV area with the 138 kV area, and their out of service reduce to 3/5 pu the available transfer capability (ATC) between these two areas.

**Fig. 9. Second N-2 test case modelled as fictitious injections.**

The meaning of the terms in Figure 9(b) is:

- $p_{(12-13)}$  = fictitious-active power flow in the line from BUS 12 to BUS 13.
- $\Delta p_{(12,12-13)}$  = fictitious-active power injection in BUS 12 associated with the outage of the line from BUS 12 to BUS 13.

- $\Delta p_{(13,12-13)}$  = fictitious-active power injection in BUS 13 associated with the outage of the line from BUS 12 to BUS 13.
- $p_{(12-23)}$  = fictitious-active power flow in the line from BUS 12 to BUS 23.
- $\Delta p_{(12,12-23)}$  = fictitious-active power injection in BUS 12 associated with the outage of the line from BUS 12 to BUS 23.
- $\Delta p_{(23,12-23)}$  = fictitious-active power injection in BUS 23 associated with the outage of the line from BUS 12 to BUS 23.

Table V shows the power flow in the two overloaded branches in the pre-contingency (Base case) and post-contingency states. Note that in the case of the post-contingency state the results are previous to corrective actions. When the traditional DC network analysis was used, equal results were obtained in simulations.

TABLE V  
BRANCHES POWER FLOW IN THE PRE AND POST CONTINGENCY STATES

Branch	Base Case Power flow (pu)	Post-contingency Power flow (pu)	Thermal Limit (pu)	Post-contingency State
10 - 11	- 2.20	- 4.01	4.0	Overloaded
11 - 13	- 2.43	- 5.01	5.0	Overloaded

By applying the formulation proposed (DC-COPF), the obtained fictitious injections were the following:

$$\Delta p_{(12,12-13)} = -\Delta p_{(13,12-13)} = p_{(12-13)} = -4.92 \text{ pu}$$

$$\Delta p_{(12,12-23)} = -\Delta p_{(23,12-23)} = p_{(12-23)} = -5.12 \text{ pu}$$

To eliminate overloads, corrective actions focused on re-scheduling generation were applied, but load-shedding wasn't necessary. These corrective actions are shown in Table VI.

TABLE VI  
CORRECTIVE ACTIONS: SECOND N-2 TEST CASE.

BUS	07	13
Generation-up (pu)	0.02	—
Generation-down (pu)	—	0.02

With these corrective actions (Table VI), generation changes from 2.65 pu to 2.63 pu in BUS 13 (Figure 9) and, consequently, power flows change from 4.01 pu to 3.99 pu and from 5.01 pu to 4.99 pu in branches from from BUS 10 to BUS 11 (transformer) and from from BUS 11 to BUS 13 (line), respectively.

#### D. Computational effort comparison

Equal software and hardware as the mentioned in the beginning of this section were applied for the comparison here presented. The key issue in this section is to show how the computation of the DC optimization problem is speeding up when the DC-COPF proposed is used.

Table VII shows a comparative study of the computational time for each simulation process. These simulations were performed for both N-1 and the N-2 contingency levels, and were extended to all the branches (lines and transformers) of the transmission and the sub-transmission systems of the IEEE-RTS.

TABLE VII  
COMPARISON OF COMPUTATIONAL TIMES

Simul Type	Contingencies Number	Computational Time	
		Traditional OPF	OPF Proposed
N-1	34	$5.32 \cdot t$	$3.26 \cdot t$
N-2	561	$55.78 \cdot t$	$42.19 \cdot t$

\*  $t = 1.00$  s

The comparative study has been carried out taking into account the conventional formulation of the DC optimization problem, and the DC-COPF proposed modelling contingencies as fictitious injections of active power. The results showed in Table VII are compared in terms of overall CPU time solution for both approaches (third and fourth columns, Table VII). Second column of Table VII includes the number of contingencies analysed.

It can be observed that the DC-COPF proposed approach provides excellent results in computation time, and the binding contingencies (line thermal limit) being correctly identified as equal as in the case of the conventional DC network analysis. Anyway, despite these excellent results, cases where not all binding contingencies are identified are to be expected as found out in [20][22], e.g. due to the reactive power flows which also contribute to branches current are neglected, lossless grid assumption of the DC model.

## VI. CONCLUSIONS

In this paper, a novel formulation (DC-COPF) is proposed in the field of the DC network analysis. Basically, this novel formulation is a corrective power-system rescheduling and load-shedding problem that exploits problem structure significantly better than previous DC analysis supported by power flow. Important to note that Topological Analysis and the rest of the classical analysis are avoided, when the method proposed is used.

The novelty of this work stems from the inclusion of fictitious injections modelling contingencies in the optimization problem. So, the DC-COPF proposed directly adjusts these fictitious injections to the post-contingency state as a consequence of the corrective actions carried out to bring the system back to its normal state. The method efficiently handles the outaged branches because they are treated as branches virtually in service.

The linear model proposed (DC-COPF) is applied to direct the solution to the “normal” operating region. Obviously, once the normal state is placed, then an AC analysis should be used to verify the results and modify limits accordingly. But, this last AC analysis is a matter no focused on in this work.

Simulations show that even if the initial operating point is far from the solution, large generation shifts are allowed and the linearization of the line flows is fairly good. Finally, simulations also show that the approach proposed is suitable to deal with both transmission and sub-transmission systems, as was shown by applying the approach proposed in the 230 kV and the 138 kV areas of the IEEE-RTS.

## VII. ACKNOWLEDGEMENTS

The authors would like to acknowledge the financial support provided by the Spanish Ministry of Science and Innovation and Cooperation and the Junta de Andalucía (Regional Government), with grants ENE2011-27984, ENE2010-18867, and

TEP-5170.

## REFERENCES

- [1] R. D. Christie, B. F. Wollenberg, and I. Wangensteen, "Transmission management in the deregulated environment," *Proceedings of the IEEE*, vol. 88, no. 2, pp. 170–195, February 2000.
- [2] G. C. Ejebe, J. G. Waight, M. Santos-Nieto, and W. F. Tinney, "Fast calculation of linear available transfer capability," in *Power Industry Computer Applications, 1999. PICA '99. Proceedings of the 21st 1999 IEEE International Conference*, July 2000, pp. 255–260.
- [3] A. G. Bakirtzis and P. N. Biskas, "Decentralised DC load flow and applications to transmission management," *IEE Proceedings-Generation, Transmission and Distribution*, vol. 149, no. 5, pp. 600 – 606, September 2002.
- [4] Y. K. Wu, "A novel algorithm for ATC calculations and applications in deregulated electricity markets," *International Journal of Electrical Power and Energy Systems*, vol. 29, no. 10, pp. 810–821, August 2007.
- [5] P. R. Gribik, G. A. Angelidis, and R. R. Kovacs, "Transmission access and pricing with multiple separate energy forward markets," *IEEE Transactions on Power Systems*, vol. 14, no. 3, pp. 865 – 876, August 1999.
- [6] ISO-NE Communications, "Power System and LMP fundamentals," ISO New England, Tech. Rep., 2010. [Online]. Available: <http://www.iso-ne.com/>
- [7] J. Mitra and C. Singh, "Incorporating the DC Load Flow Model in the Decomposition-Simulation Method of Multi-Area Reliability Evaluation," *IEEE Trans. Power Syst.*, vol. 11, no. 3, pp. 1245 – 1254, August 1996.
- [8] K. Purchala, L. Meeus, D. Van Dommelen, and R. Belmans, "Usefulness of DC Power Flow for Active Power Flow Analysis," in *Proc. Power Engineering Society General Meeting, IEEE*, vol. 1, June, 12th - 16 th 2005, pp. 454 – 459.
- [9] B. Stott, J. Jardim, and O. Alsaç, "DC Power Flow Revisited," *IEEE Trans. Power Syst.*, vol. 24, no. 3, pp. 1290 – 1300, August 2009.
- [10] H. L. Willis, *Power Distribution Planning: Reference book*, 2nd ed. New York-Basel, NY: Marcel Dekker, Inc., 2004.
- [11] A. Gómez-Expósito, A. J. Conejo, C. Cañizares, *et al.*, *Electric Energy Systems: Analysis and Operation*, ser. Electric Power Engineering, L. L. Grigsby, Ed. Boca Raton, FL 33487-2742: CRC Press, 2009.
- [12] J. A. Momoh, M. E. El-Hawary, and R. Adapa, "A Review of Selected Optimal Power Flow Literature to 1993 Part 11: Newton, Linear Programming and Interior Point Methods," *IEEE Transactions on Power Systems*, vol. 14, no. 1, pp. 105 – 111, February 1999.
- [13] P. W. Sauer, "On the Formulation of Power Distribution Factors for Linear Load Flow Methods," *IEEE Transactions on Power Apparatus and Systems*, vol. PAS-100, no. 2, pp. 764 – 770, February 1981.
- [14] N. Srinivasan, K. S. Prakasa Rao, and C. S. Indulkar, "Simulation of line and transformer outages in power systems using constant-sensitivity matrix," *International Journal of Electrical Power and Energy Systems*, vol. 9, no. 1, pp. 56 – 62, January 1987.
- [15] B. Stott and J. L. Marinho, "Linear Programming for Power-System Network Security Applications," *IEEE Transactions on Power Apparatus and Systems*, vol. PAS-98, no. 3, pp. 837 – 848, May 1979.
- [16] Y. Zhao, N. Zhou, J. Zhou, and X. Zhao, "Research on Sensitivity Analysis for Composite Generation and Transmission System Reliability Evaluation," *Proceedings of the International Conference on Power System Technology, 2006 (PowerCon 2006)*, vol. 1, pp. 1 – 5, October 2006.
- [17] P. J. Martínez-Lacanina, J. L. Martínez-Ramos, A. de la Villa-Jaén, and A. Marano-Marcolini, "A Novel Formulation for DCOPF Based on Fictitious Nodal Injections Obtained from Sensitivity Matrix," *International Review of Electrical Engineering*, vol. 7, no. 3, pp. 4548 – 4586, June 2012.
- [18] F. Li and R. Bo, "DCOPF-Based LMP Simulation: Algorithm, Comparison With ACOPF, and Sensitivity," *IEEE Transactions on Power Systems*, vol. 22, no. 4, pp. 1475 – 1485, November 2007.
- [19] K. R. C. Mamandur and G. J. Berg, "Efficient Simulation of Line and Transformer Outages in Power Systems," *IEEE Transactions on Power Apparatus and Systems*, vol. PAS-101, no. 10, pp. 3733 – 3741, October 1982.
- [20] A. Marano-Marcolini, F. Capitanescu, J. L. Martínez-Ramos, and L. Wehenkel, "Exploiting the Use of DC SCOPF Approximation to Improve Iterative AC SCOPF Algorithms," *IEEE Transactions on Power Systems*, vol. 27, no. 3, pp. 1459 – 1466, August 2012.
- [21] P. J. Martínez-Lacanina, J. L. Martínez-Ramos, and A. de la Villa-Jaén, "Sensitivity-based external equivalent for reliability assessment of subtransmission & distribution systems," in *Proceedings 17th Power Systems Computation Conference (PSCC-2011)*, KTH, Stockholm, Sweden, August, 22nd - 26th 2011.
- [22] T. J. Overbye, X. Cheng, and Y. Sun, "A Comparison of the AC and DC Power Flow Models for LMP Calculations," *Proceedings of the 37th Annual Hawaii International Conference on System Sciences (HICSS'04)*, vol. 2, pp. 20 047 – 20 055, January 2004.

- [23] P. W. Sauer, K. E. Reinhard, and T. J. Overbye, "Extended factors for linear contingency analysis," in *Proceedings of the 34th Annual Hawaii International Conference on System Sciences (HICSS-2001)*, Maui, Hawaii, USA, January, 3rd -6th 2001, pp. 697 – 703.
- [24] R. T. S. Task Force, "The IEEE Reliability Test System - 1996," *IEEE Trans. Power Syst.*, vol. 14, no. 3, pp. 1010 – 1020, August 1999.
- [25] F. Capitanescu and L. Wehenkel, "A new iterative approach to the corrective security-constrained optimal power flow problem," *IEEE Transactions on Power Systems*, vol. 23, no. 4, pp. 1533 – 1541, November 2008.
- [26] —, "Redispatching Active and Reactive Powers Using a Limited Number of Control Actions," *IEEE Transactions on Power Systems*, vol. 26, no. 3, pp. 1221 – 1230, August 2011.
- [27] M. K. Enns, J. J. Quada, and B. Sackett, "Fast Linear Contingency Analysis," *IEEE Transactions on Power Apparatus and Systems*, vol. PAS-101, no. 4, pp. 783 – 791, April 1982.
- [28] K. W. Hedman, R. P. O'Neill, E. B. Fisher, and S. S. Oren, "Optimal Transmission Switching With Contingency Analysis," *IEEE Transactions on Power Systems*, vol. 24, no. 3, pp. 1577 – 1586, August 2009.
- [29] A. J. Wood and B. F. Wollenberg, *Power Generation, Operation, and Control*, 2nd ed. New York, NY: John Wiley&Sons, Inc., 1996.
- [30] R. Baldick, "Variation of distribution factors with loading," *IEEE Transactions on Power Systems*, vol. 18, no. 4, pp. 1316 – 1323, November 2003.
- [31] W. Li, "A successive linear programming model for real-time economic power dispatch with security," *Electric Power Systems Research*, vol. 13, no. 3, pp. 225 – 233, December 1987.
- [32] S. Fliscounakis, F. Zaoui, G. Simeant, and R. Gonzalez, "Topology Influence on Loss Reduction as a Mixed Integer Linear Programming Problem," in *Proc. IEEE Lausanne Power Tech Conference*, vol. 1, Lausanne, Switzerland, July, 1st - 5th 2007.
- [33] F. Capitanescu, J. L. Martinez Ramos, P. Panciatici, D. Kirschen, A. Marano Marcolini, L. Platbrood, and L. Wehenkel, "State-of-the-art, challenges, and future trends in security constrained optimal power flow," *Electric Power Systems Research*, vol. 81, no. 8, pp. 1731 – 1741, August 2011.
- [34] A. Mehrtash, P. Wang, and L. Goel, "Reliability evaluation of restructured power systems using a novel optimal power-flow-based approach," *Generation, Transmission Distribution, IET*, vol. 7, no. 2, pp. 192 – 199, February 2013.
- [35] T. N. Santos and A. L. Diniz, "Alternative approaches to consider DC-power flow with losses in a linear program for short term hydrothermal scheduling," in *Transmission and Distribution: Latin America Conference and Exposition (T D-LA), 2012 Sixth IEEE/PES*, Montevideo (Uruguay), 3-5 September 2012, transmission and Distribution: Latin America Conference and Exposition (T&D-LA), 2012 Sixth IEEE/PES.
- [36] B. Zhang and Z. Yan, *Advanced Electric Power Network Analysis*, 1st ed., T. Learning, Ed. New Tech Park (Lobby H), Singapore: Cengage Learning Asia Pte Ltd, 2011.
- [37] B. A. McCarl. (2011) GAMS User Guide, versión 23.6. [Online]. Available: [www.gams.com](http://www.gams.com)
- [38] (2009) CPLEX 10 User Manual. [Online]. Available: [www.gams.com](http://www.gams.com)

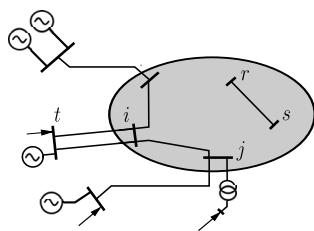

Fig. 1. Electric Power System in Normal State.

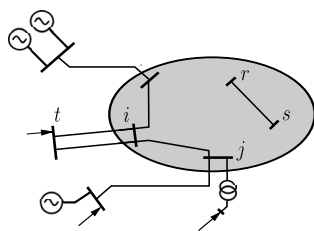

Fig. 2. Generator out of service at node  $t$ .



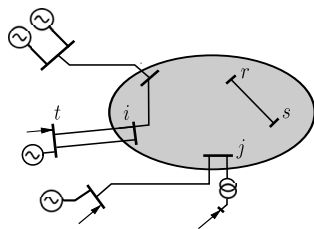

Fig. 3. Branch  $ij$  out of service.

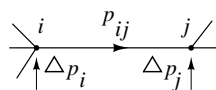

Fig. 4. Branch  $ij$  virtually in service. Failure modelled as two fictitious nodal injections.

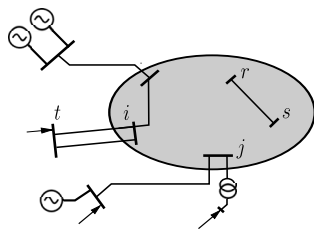

Fig. 5. Generator at node  $t$  and branch  $ij$  simultaneous out of service.

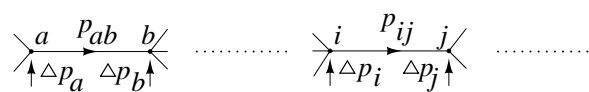

Fig. 6. Multiple contingency of branches modelled as fictitious nodal injections.

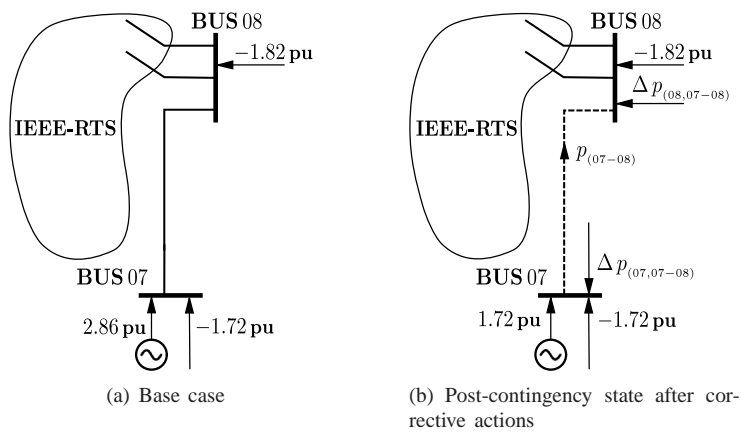

Fig. 7. N-1 test case modelled as fictitious injections.

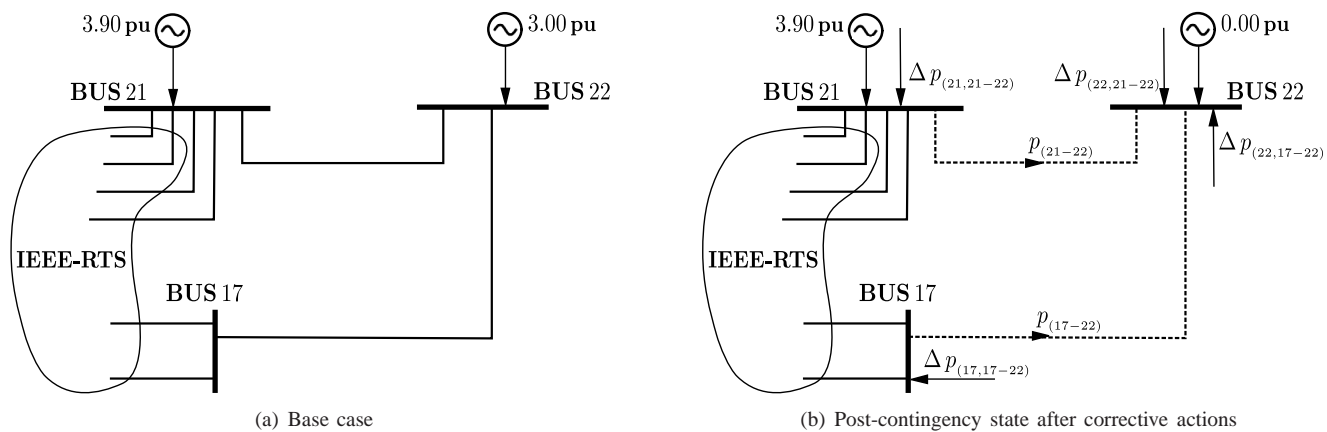

Fig. 8. First N-2 test case modelled as fictitious injections.

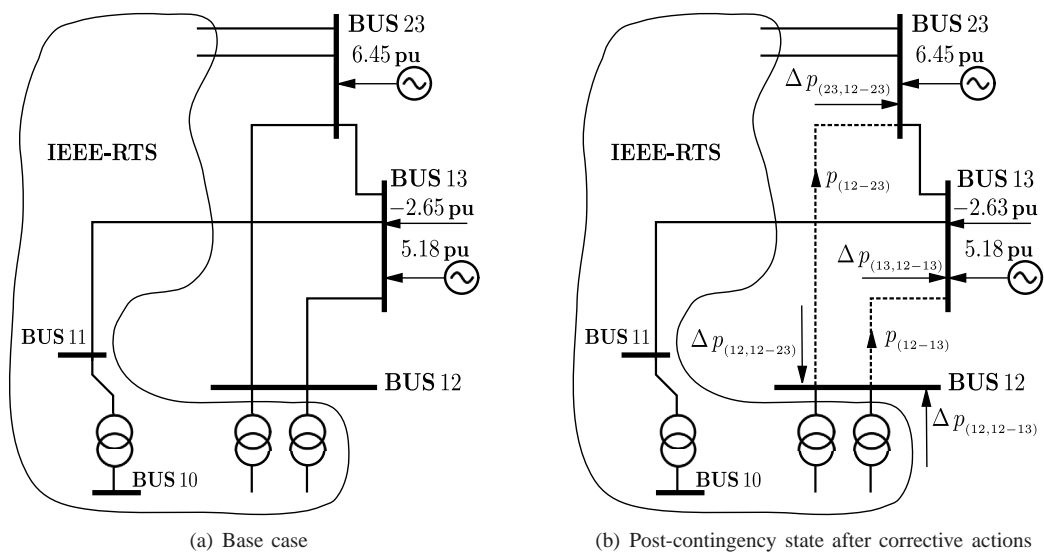

Fig. 9. Second N-2 test case modelled as fictitious injections.