

## Optimization of connections for spatial modular structures

Rodríguez-León, M.T.<sup>1</sup>; Sánchez, J.<sup>2</sup> & Vázquez, Enrique<sup>3</sup>

### ABSTRACT

Every year Seville's city Council orders the construction of a giant gateway for the celebration of the April Fair. These constructions, whose dimensions are approximately 50 meters length, 40 meters height and variable depth of 4 to 5 meters, are spatial modular structures composed of steel tubular elements connected by clamps and covered by wood boards.

The consideration or not of the eccentricities introduced by the connection element as well as the determination of the stiffness to consider is one of the major problems when developing the analysis model. The construction company aims to achieve their optimization in order to reduce the final cost.

This paper investigates about how different ways of modeling these connections affects the optimization of the final model. The extent to which the modification of the position of the eccentricities influences the optimization is also discussed, as this aspect is difficult to control on site.

*Keywords: framework, eccentricity, offset, clamp, stiffness.*

### 1. INTRODUCTION

Seville April Fair gateways are a perfect example of spatial modular structures. They are constituted by tubular elements connected by clamps in a modular design, so that efforts are distributed in an isotropic network, and then in a uniform way.

It consists of vertical planes separated 1'00 m in the OX direction, hatched with horizontal planes separated 1'70 m in the OZ direction and transverse planes whose separation is variable, thus generating simple prismatic modules which are diagonalized in every face (Fig. 1). These prismatic modules are repeated in the front elevation and in the transverse direction to fit the contour defined by the given shape, which is different every year, thus forming an orthogonal grid (Fig. 2).

The tube section is constant throughout the model, with an outer diameter of 48 mm and an inner diameter of 42 mm. They are made of A42b, according to the former nomenclature for steel, taking into account that these tubes are reused every year, now equivalent to S235 JR. The main characteristics of A42b steel are:  $\rho = 78'50 \text{ kN/m}^3$ ,  $E = 2'1 \cdot 10^8 \text{ kN/m}^2$ ,  $f_y = 260.000 \text{ kN/m}^2$  and  $f_u = 420.000 \text{ kN/m}^2$ .

---

<sup>1</sup> Department of Mechanics and Structures. University of Seville (SPAIN). [mtrl@us.es](mailto:mtrl@us.es)

<sup>2</sup> Department of Mechanics and Structures. University of Seville (SPAIN). [joseess@us.es](mailto:joseess@us.es)

<sup>3</sup> Department of Mechanics and Structures. University of Seville (SPAIN). [ev@us.es](mailto:ev@us.es)

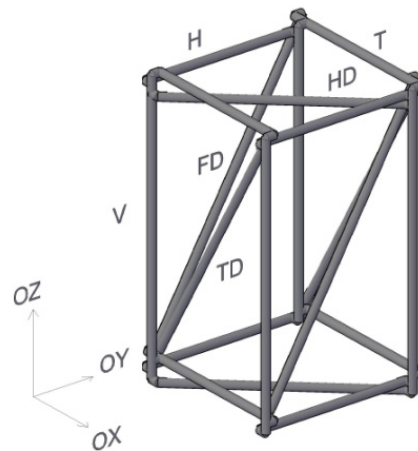

**Figure 1.** Prismatic module,  $OX = 1'00m$ ,  $OY = Variable$ ,  $OZ = 1'70 m$ .



**Figure 2.** Spatial structure during the building process.

### 1.1. Continuous bracing members

The tubes considered every year are continuous, so that each braced member must be connected at intermediate points to define the simple prismatic module with the considered dimensions. This connection is solved with coupling clamps in the case of orthogonal planes (Fig. 3) or with screwed inner sleeves- extension joints, when it comes to giving continuity thereto. With couplers it is ensured an effort transmission of 20 kN both in tension and compression, whereas extension joints are dimensioned to withstand the total resistant capacity of the tubes.

In the case of the couplers, the torque applied to the screw closure of the two half-rings of the coupler generates the force opposed to sliding. With this orthogonal coupler it is always possible to solve any union between two tubes without having to resort to swivel couplers, since it is always possible in our structural configuration to seek for orthogonal unions.



**Figure 3.** Clamp element for the connection of tubes in orthogonal planes.

The goal of this paper is to determine how to represent appropriately the couplers for orthogonal unions, provided the computer can cope, since any deviation in the geometry or the mechanical properties of these lead to erroneous results. There are two important aspects on which further:

Firstly, it is necessary to determine the elastic stiffness characteristics for the couplers, since it is supposed that the flexibility of these connections affects the behavior of the matrix structure.

Moreover, it can be observed that the solution considered produces eccentricities in the transmission of forces. The modeling of such eccentricities complicates the analysis model, since it is necessary to take into account that the joint can reach up to a maximum of six directions, which corresponds to a total of twelve tubes, one in each sense for each direction, but this is further complicated when multiple tubes are arranged in parallel to achieve the necessary strength. Therefore, it is necessary to assess the influence of the consideration of these eccentricities on the final results.

## 2. DETERMINATION OF ELASTIC STIFFNESS CHARACTERISTICS FOR COUPLERS

It was impossible to test a model coupler to discover its elastic stiffness characteristics, by not having the means to do so. Therefore, it was decided to extrapolate these values from a test performed on a similar model coupler [1]. The measurement of the coupler characteristics was determined according to Figure 4, where a short vertical tube with its ends clamped is connected with a coupler to a horizontal tube, and different load conditions are applied to obtain the coupler's elastic characteristics, which are referred in Table 1. For the directions in which the model coupler is relatively stiff, i.e. 1, 3 and 9, the elastic characteristics are difficult to ascertain, because of very small deflections occurring. Therefore, a conjectural stiffness of  $10^9$  kN/m was for these directions, producing fixity factors almost up to unity (i.e. virtually rigid).

**Table 1.** Model coupler elastic stiffness characteristics for the referenced test

<b>k1=k3 (kN/m)</b>	<b>k5 (kN·m)</b>	<b>k7=k11 (kN·m)</b>	<b>k9 (kN/m)</b>
$10^9$	$15'80 \cdot 10^{-3}$	$16'80 \cdot 10^{-3}$	$10^9$

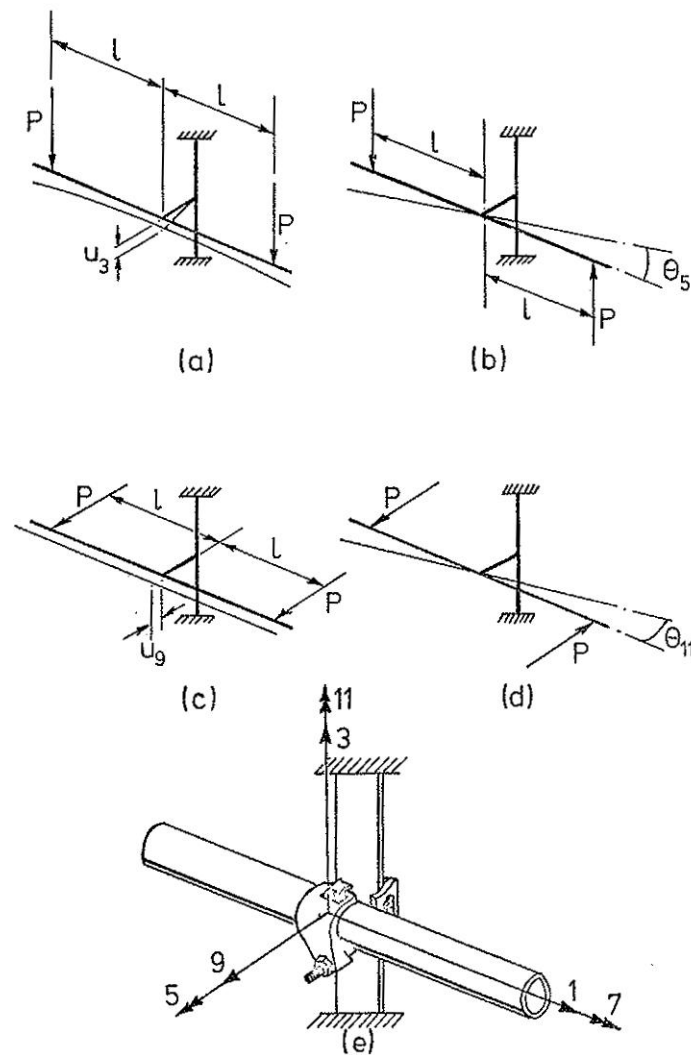

Figure 4. Numbered directions on coupler's stiffness characteristics test.

To extrapolate the stiffness characteristics obtained in the referenced test it is necessary to consider the geometrical and mechanical properties of the tubular elements tested in comparison with the ones used at Fair gateways (Table 2). In particular they will be taken as reference values for extrapolation the values of moment of inertia and modulus of elasticity of the tubular member. Then, the elastic stiffness characteristics for the couplers used at Seville Fair gateways are determined (Table 3).

Table 2. Geometrical and mechanical properties for tubular elements

	$\phi$ (m)	A (m <sup>2</sup> )	I (m <sup>4</sup> )	E (kN/m <sup>2</sup> )	G (kN/m <sup>2</sup> )
Fair gateways	$48'00 \cdot 10^{-3}$	$424'00 \cdot 10^{-6}$	$107.800 \cdot 10^{-12}$	$210'00 \cdot 10^6$	$80'77 \cdot 10^6$
Referenced test	$6'35 \cdot 10^{-3}$	$31'50 \cdot 10^{-6}$	$79'30 \cdot 10^{-12}$	$30'00 \cdot 10^6$	$4'30 \cdot 10^6$

**Table 3.** Model coupler elastic stiffness characteristics for Fair gateways

<b>k1=k3 (kN/m)</b>	<b>k5 (kN·m)</b>	<b>k7=k11 (kN·m)</b>	<b>k9 (kN/m)</b>
$9'52 \cdot 10^{13}$	1503'49	1598'65	$9'52 \cdot 10^{13}$

### 3. EVALUATION OF ELASTIC AND ECCENTRIC CONNECTIONS FOR FAIR GATEWAYS

For a first approach a simple model will be used, that will consist of the repetition of three simple modules in the OX direction, two simple modules in the OY direction and four simple modules in the OZ direction (Figure 5). This model will have pinned joints at its base, and the necessary links for the provision of the symmetrical plane corresponding to OYZ will be provided. The actions considered will be the permanent load due to the wood panels that cover the structure, whose value is  $0'20 \text{ kN/m}^2$ , and the wind load, whose value is  $0'85 \text{ kN/m}^2$ .

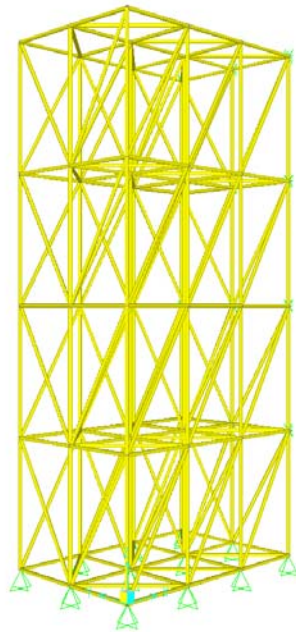

**Figure 5.** Analysis model considered for the study.

The following analyzes were performed on the model thus generated for further comparison, using the software SAP2000 v.11.

Analysis 01: No offset + Rigid joints.

Analysis 02: No offset + Released joints.

Analysis 03: No offset + Elastic joints (no extrapolated values).

Analysis 04: No offset + Elastic joints (extrapolated values).

Analysis 05: Offset + Rigid joints.

Analysis 06: Offset + Released joints.

Analysis 07: Offset + Elastic joints (no extrapolated values).

Analysis 08: Offset + Elastic joints (extrapolated values).

For the eccentricities considered in the analysis models developed in SAP2000, the only known information is that the actual distance measured between the axes of the tubular elements to be joined is 5'50 cm, due to the presence of the coupler element. Taking into account that it is not possible to overlap the tubes, the distance between tubes will always be 5'50 cm or multiple of this value. In the analysis model these eccentricities will not be symmetrical, although the overall geometry will present symmetry (Figure 6).

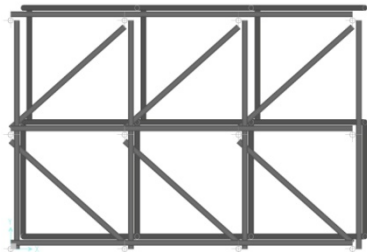

**Figure 6.** Analysis model with representation of the eccentricities. Top view (OXY).

When modeling the eccentricities detailed before, it is necessary to consider a point of reference against which to set the position of the ends of that spatial element. It will be taken as reference point the end of vertical tubes, so that these will be the sole spatial components whose ends will not have an eccentric position. For this reason, when considering elastic joint, vertical tubes will always be considered rigid at its ends [2].

In addition to this, the eccentricities considered by the software SAP2000 are not geometric eccentricities. When consulting the coordinates on the ends of any element, it can be checked that these coordinates are not displaced, so that these eccentricities are only considered for calculation but not for modeling. That is why this option does not allow to generate curved geometries, and it is only valid for orthogonal geometries [3, 4].

Regarding the loads consideration, the different loads corresponding to different load cases will never be applied in joints, since the eccentricity has been assigned to the end of the tubular element and then eccentricities would not be considered. For this reason, it is necessary to apply loads to the end of the bar elements.

Once the definition of the analysis model has been set, it is time to compare and summarize the different analysis performed (Tables 4-5):

**Table 4.** Comparison between different analysis cases (01, 02, 03, 04) (D·1'35 + W·1'5)

	Displacement OY (m)		Axial Force (kN)	
	Joint 85		Frame 1	
Case a	0'004		15'444	
Case b	0'004		15'467	
Case c	0'004		15'500	
Case d	0'004		15'438	

**Table 5.** Comparison between different analysis cases (05, 06, 07, 08) (D·1'35 + W·1'5)

	Displacement OY (m)		Axial Force (kN)	
	Joint 85		Frame 1	
Case e	0'005		12'955	
Case f	0'010		7'617	
Case g	0'010		7'660	
Case h	0'005		12'936	

For analysis cases 05, 06, 07, 08, which represent models that consider eccentricities, it is shown that for analysis case (05) and for analysis case (08) the axial stress distribution at vertical tubes is homogeneous, but when it comes to analysis case (06) or analysis case (07) joints are no longer elastic and they become plastic (Figures 7-8) [5,6].

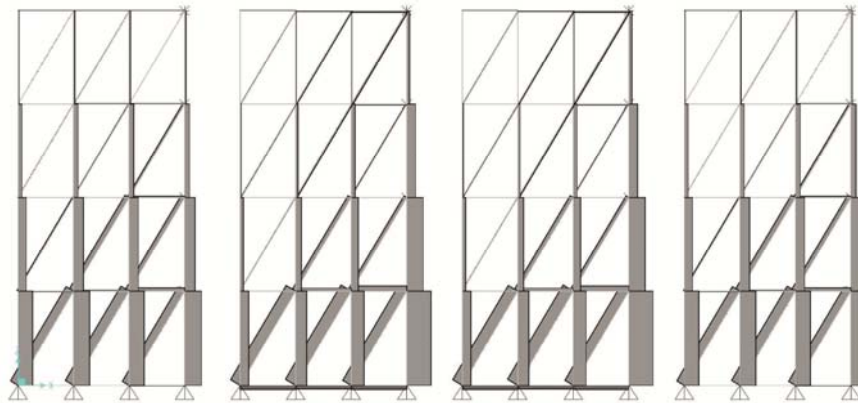

**Figure 7.** Axial force diagram for analysis cases 05, 06, 07, 08. Front view (OXZ).

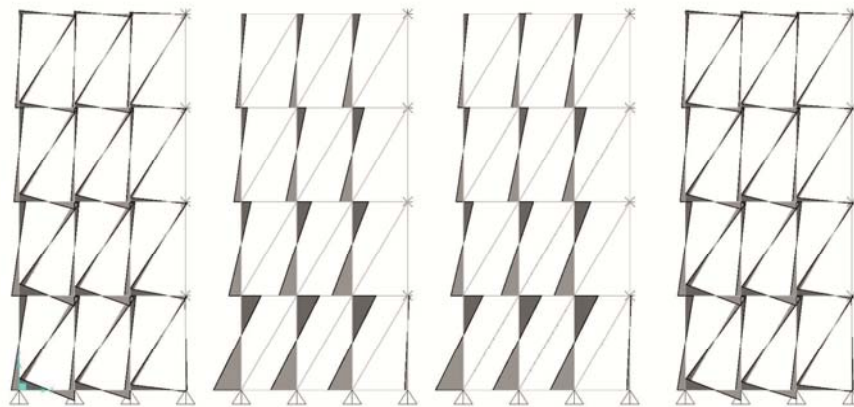

**Figure 8.** Moment 3-3 diagram for analysis cases 05, 06, 07, 08. Front view (OXZ).

### 3.1. Consideration of different stiffness values

The analysis performed so far shows that stiffness values are not influential if eccentricities are not considered (01, 02, 03, 04), but they become quite important when these eccentricities are modeled (05, 06, 07, 08) [7]. So the next question is to assess the importance of the stiffness values adopted, taking into account that so far only two different values have been adopted: those obtained from the experimental referenced test, and those obtained from extrapolation of the previous ones. After this assessment, it is noted that in case of elastic joints with stiffness of order  $10^3$  kN·m the results obtained are very similar to those obtained for rigid joints, and over the order  $10^5$  kN·m they are identical (Table 6) [8].

**Table 6.** Analysis cases with eccentricities considering different stiffness values ( $D \cdot 1'35 + W \cdot 1'5$ )

Offset + Elastic joints				
k (kN·m)	Displacement OY (m) Joint 85	Difference with rigid joints (%)	Axial force (kN) Frame 1	Difference with rigid joints (%)
k7=k11=0'1176 k5=0'1106	0'010	79'11%	7'900	63'98%
k7=k11=1'176 k5=1'106	0'010	68'39%	9'414	37'61%
k7=k11=11'76 k5=11'06	0'007	41'96%	11'851	9'31%



k7=k11=117'60 k5=110'60	0'006	11'82%	12'746	1'64%
k7=k11=1176'0 k5=1106'0	0'006	1'66%	12'929	0'20%
k7=k11=11760 k5=11060	0'005	0'18%	12'953	0'01%
k7=k11=117600 k5=110600	0'005	0%	12'955	0%

### 3.2. Consideration of randomness in the position of eccentricities

The position of the eccentricities has been considered constant during the overall construction of the structure but in fact this aspect is very difficult to control on site. For example, it is difficult to ensure if horizontal tubes are connected to vertical ones on the left or on the right side (Figure 9). This aspect will be considered for the analysis model to assess how this situation affects the results obtained (Table 7):



**Figure 9.** Different positions considered for eccentricities between horizontal and vertical tubes. Top view (OXY).  
1: Horizontal tubes at left side of vertical tubes; 2: Horizontal tubes at right side of vertical tubes; 3: Horizontal tubes at both sides of vertical tubes.

**Table 7.** Comparison between different positions considered for eccentricities between horizontal and vertical tubes

Static Linear Analysis (D·1'35 + W·1'5) Offset + Rigid joints		
	Displacement OY (m) Joint 85	Axial force (kN) Frame 1
Model 1	0'005	12'955
Model 2	0'005	12'434
Model 3	0'005	13'286

#### 4. APPLICATION TO SEVILLE FAIR GATEWAYS

The analysis models corresponding to the Fair gateways considered and used for the real construction of these structures have been solved with released joints and no eccentricities, but this solution does not really correspond to the real construction process that takes place, since eccentricities do really exist and they must be considered for an accurate analysis [9].

To avoid modeling eccentricities it could have been chosen to introduce a bending moment equal to the axial force multiplied by the distance to the tube axis, but this solution will also complicate the calculation process, so that finally the solution adopted is to penalize the maximum permissible compression load when performing the dimensioning process. Moreover, from the point of the dimensioning process, there is a factor that keeps this analysis on the side of safety: considering released joints when in fact couplers don't allow totally free rotations means that tubes are dimensioned for a higher bending moment than the real one, so that somehow, the penalty for eccentricities is being compensated.

From the point of view of the dimensioning process for the structure [10], this solution could be adopted as valid, but nevertheless, with this solution the deformability of the global model introduced by eccentricities that has been demonstrated is not being considered. Therefore, it is necessary to compare the actual analysis model for Fair gateways solved without eccentricities and released joints against another analysis model in which eccentricities are considered as well as stiffness values extrapolated from the above analysis (Table 8).

**Table 8.** Seville Fair gateway 2011. Consideration or not of eccentricities, and adoption of different stiffness values

	<b>No offset + Rigid joints</b>	<b>Offset + Rigid joints</b>	<b>Offset + Elastic joints</b>
Period T1 (s)	0'463	0'475	0'475
Displacement OY (m)	0'133	0'136	0'136

Axial efforts obtained for each analysis model at vertical tubes corresponding to the front plane subjected to compression stress are also compared (Figure 10), and it is noted that the results obtained in the second and third proposal are virtually identical, and differ somewhat with respect to the first proposal.

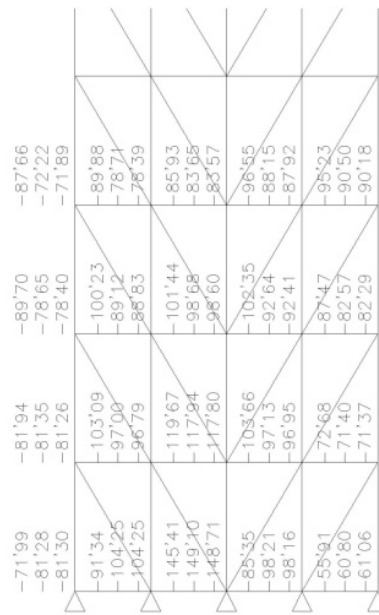

**Figure 10.** Seville Fair gateway 2011. Front view (OXZ). Axial efforts (kN). 1: No offset + Released joints; 2: Offset + Rigid joints; 3: Offset + Elastic joints.

## 5. CONCLUSIONS

The first conclusion has been obtained from the consideration or not of eccentricities. When considering eccentricities it is necessary to evaluate the stiffness of the joint element, but if eccentricities are not considered, there is no difference between rigid, released or elastic joints, as long as the prismatic module is diagonalized in every direction.

As in our particular structure eccentricities do exist, the analysis model should consider these eccentricities, and then, the stiffness of the coupler must be evaluated and considered for the analysis model. However, it is really difficult to consider eccentricities because this structure does not only work with unitary sections, but it considers multiple sections from the unitary one. Each multiple section presents different eccentricity, so that the analysis model becomes really complicated to be determined.

With regard to the joint stiffness, if using the stiffness values extrapolated from the referenced test it is possible to obtain similar results to those obtained with rigid joints. In fact, with samples of material available, it seems that rotations are prevented around any of three local axes, so it is recommended to work with rigid joints so that the results may be similar to the ones obtained for the real unknown stiffness values.

The second conclusion has been obtained from the consideration of the randomness of the position of the eccentricities, so that this randomness does not affect significantly the final results.

## REFERENCES

- [1] Lightfoot, E., LeMessurier, A. Instability of space frames having elastically connected and offset members. In Proc. of the 2<sup>nd</sup> Int. Conf. on Space Structures (pp. 143-149). England: Guilford.
- [2] Subramanian, N. & Ganapathy Chettiar, C. (1980). The computer analysis of space frames with offset members. *Computer & Structures*, 11, 297-303.
- [3] *CSI Analysis Reference Manual*. Rev.8 Berkeley, California, USA.
- [4] Rodríguez-León, M.T. *Análisis estructural de las portadas de la Feria de Sevilla: dimensionado, validación experimental y optimización*. Dirigida por D. José Félix Escrig Pallarés y D. José Sánchez Sánchez. Tesis doctoral. Universidad de Sevilla, Escuela Técnica Superior de Arquitectura, 2014.
- [5] Chandramouli, S., Wang, S. & Blandfor, G. (1994). Stability response of flexibly connected cold-formed steel spaceframes. *Thin-walled structures*, 18, 333-346.
- [6] Razzaq, Z. & Moossa, N. (1980). Elastic instability of unbraced space frames. *Journal of the Structural Division*, Vol. 106, nº 7, 1389-1400.
- [7] Richard Liew, J.Y., Chen, H., Shanmugam, N.E. & Chen, W.F. (2000). Improved nonlinear plastic hinge analysis of spaceframe structures. *Engineering Structures*, 22, 1324-1338.
- [8] Richard Liew, J.Y. & Tang, L.K. (2000). Advanced plastic hinge analysis for the design of tubular spaceframes. *Engineering Structures*, 22, 769-783.
- [9] Wardenier, J. (2002). *Perfiles tubulares en aplicaciones estructurales*. Álava: Instituto para la construcción tubular.
- [10] Eekhout, M. et al. (2002). *Analysis, design and construction of steel space frames*. London: Thomas Telford.