

Fuzzy logic application for improving speed control and captured energy using the wind speed information for wind turbines

M.M.Prats*, E.Galván*, J.M.Carrasco*, J..A.Sánchez*, L.G.Franquelo*, C. Batista**

* Dpto. de Ingeniería Electrónica. Escuela Superior de Ingenieros. Universidad de Sevilla
Camino de los Descubrimientos s/n 41092 Sevilla. Spain. Tel: 954487372

** MADE Energías Renovables, S.A. Torre Europa. Pº Castellana 95, planta 29, 28046 Madrid. Spain

Abstract

This paper describes a fuzzy logic application for improving the variable speed and blade pitch wind turbine performance. The simulated model is going to be implemented using a programmable logic controller as the fuzzy controller designed. The used fuzzy controller as well as improving transition between power optimization and power limitation of the wind turbine at rated wind speed, it also permits to improve the captured wind energy at high wind speed working conditions using wind speed as input controller.

Keywords: Fuzzy Control, variable Speed Wind Turbines, Blade Pitch Control, Torque Control, Power Optimization.

1. Introduction

The power coefficient C_p is the ratio between mechanic power and the power captured from the wind. The ratio between blade speed and wind speed is the tip-speed-ratio λ .

There are two control methods to limit the captured wind power at high wind speed from 12.5 to 25 m/s [1]. Stall regulation is a passive control, which uses turbulences to decrease power coefficient C_p [2]. This control method provides a power that is smaller than rated power. The other strategy of control based on blade-pitch control permit to keep constant the rated power. Variable speed, horizontal axis grid integration wind turbines using torque and blade-pitch control improve the captured wind energy [1][3][4][5]. In this work these control methods will be used. Maximum power coefficient C_p and optimum tip-speed-ratio λ will be achieved using blade pitch control. These kinds of wind turbines with torque and blade-pitch linear control provide an excellent performance of the closed loop system [1][3][4]. However, this performance can be enhanced by using fuzzy control.

Proper design of fuzzy controllers makes them superior to traditional linear control techniques [6]. Relevant fuzzy logic applications can be found in non-linear control because a properly designed fuzzy controller can outperform traditional PI and PID controllers [7][8]. The application of fuzzy logic makes it possible to find efficient solutions in complicated systems designed from the human experience [9].

The heuristic approach used in this work improves the performance of the closed loop system.

The presented paper is based on the previous developed work explained in [11]. Using the wind speed as a new input of the fuzzy controller, an improvement of the speed control and captured energy at high wind speed is achieved.

2. Description of the dynamic system.

The wind turbine is controlled by exclusively one fuzzy controller. This controller is used for blade pitch controlling at high wind speed and for torque controlling at low wind speed.

A non-linear model of the wind turbine from the inputs is used. In reference [3] the model of the wind turbine used in this work is presented.

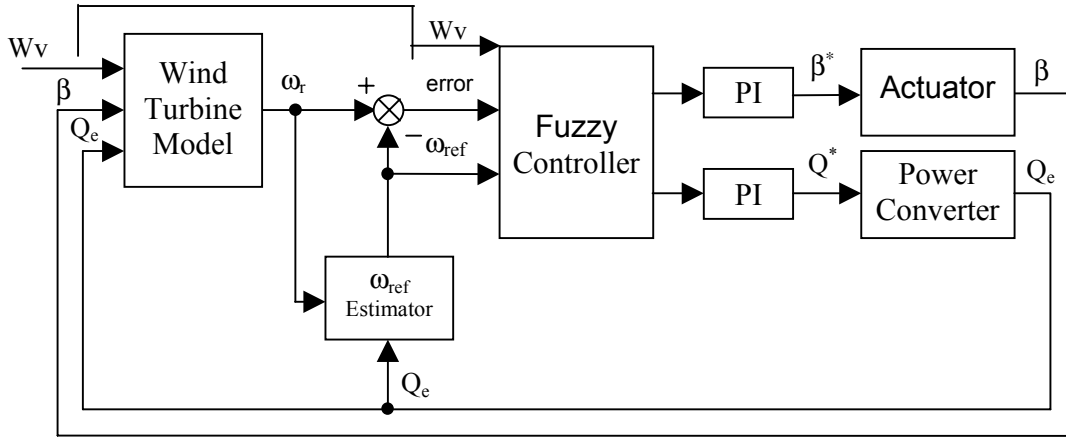

Figure.1. Structure of the proposed fuzzy controller

A frequency converter decouples the generator from the grid, allowing the rotor speed to vary by controlling the generator reaction torque [5].

This power converter works as a driver, controlling the torque generator by using a vectorial control strategy. Since mechanic response is slower than electric response, the dynamic of the electric generator is not included in the wind turbine model. The designed system is controlled by a torque command. This command is instantaneously transmitted to the shaft. It will be the load torque of the wind turbine. The following equation provides the expression of the aerodynamic torque of the wind turbine.

$$Q_L = \rho C_p(\lambda) \pi R^5 w_L^2 / 2\lambda^3 \quad (1)$$

For steady state operation at tip speed ratio for optimum power coefficient, C_{p_o} , the equation can be reduced to:

$$Q_L = \rho C_{p_o}(\lambda) \pi R^5 w_L^2 / 2\lambda_o^3 = K_\lambda w_L^2 \quad (2)$$

This equation is often used for open loop variable speed control of a wind turbine. When the generator torque demand is set to $K_\lambda w_L^2$. Where w_L is the measured generator speed. This ensures that in the steady state the turbine will

work with an optimum tip speed ratio and the corresponding maximum power coefficient.

If pitch angle control is used in the system along with variable speed, better performance is obtained. The power and speed can be limited through rotor pitch regulation.

At low winds it is possible to maximize energy capture following a constant tip speed ratio load line which corresponds to operation at the maximum power coefficient. During that time, the pitch angle is adjusted to a constant value, the maximum power pitch angle. At very low wind speed it is not possible to follow this curve because there is a minimum allowed operating speed. Then the wind turbine is operated at a constant speed W_{min} .

At high wind speed it is necessary to limit the torque Q_n or power P_n of the generator to a constant value. The main problem is to control the speed at rate value with high wind speed and high variation of this. The main objective in this work is to obtain a high performance control system achieving rated rotor speed (1500 rpm) and optimizing the obtained power.

3. Fuzzy controller description

The developed control system has integrated a fuzzy controller for torque and blade pitch control. The fuzzy sets have been heuristically

defined. Given the rules and membership functions, the fuzzy controller produces the crisp and continuous nonlinear input/output (I/O) map [10].

In Figure 1 the structure of the proposed fuzzy controller is shown for 12 m/s wind speed. The inputs of the fuzzy controller are the speed error, the measured rotor speed and wind speed. The outputs are the reference angle and the reference electrical torque.

The fuzzy controller employs normalized triangle membership functions. The fuzzy rules and membership functions have been designed to optimize the captured power at low wind speed and to limit the captured power at high wind speed. The transition between control regions is improved.

The resulting control surfaces for torque and pitch blade control are shown in Figure 3 and Figure 4 respectively.

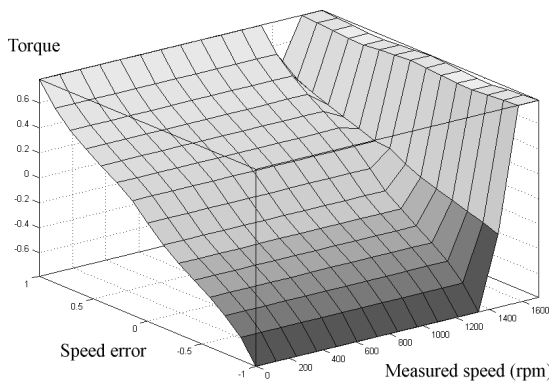

Fig.3. Fuzzy surface for Torque

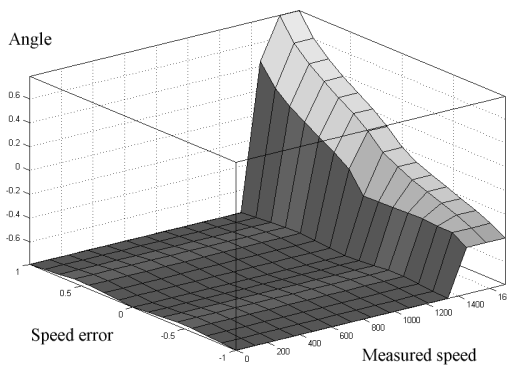

Fig.4. Fuzzy surface for Angle.

4. Simulation results

In this work, the fuzzy control strategy as well as allows to extract a small improvement in energy capture in low and high wind speed, they can also enhance performance in the transition between power optimization and power limitation in rated wind speed. This model has been implemented with MATLAB (Simulink) software. Simulations from different wind speed inputs cases show better results for the fuzzy control system if it is compared with the linear control system. It is used for improving wind energy capture.

Figure 5 shows the wind speed used for the simulations. The mean speed is 20m/s that is considered here as high wind speed. In this case the system works almost all the time above the transition zone.

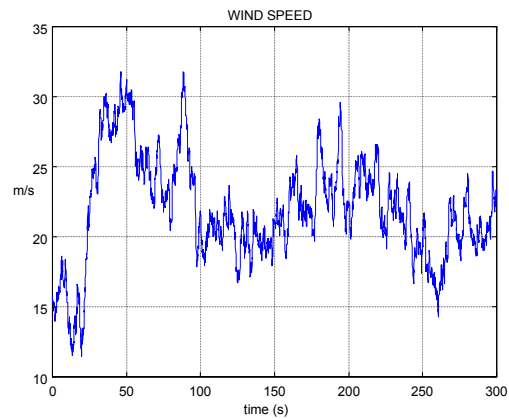

Fig.5. Wind speed used for the simulations.

Fig. 6 - 7 show the power captured by linear controller and Fuzzy controller respectively. Simulation results in high wind speed conditions (20 m/s mean value) are shown in table I.

As it is shown in table I, Fuzzy controller over conventional linear controller presents better speed and blade pitch control at high wind speed, also, captured power has been increased about 0.8%.

4. Conclusions

In this work, a fuzzy logic application has been developed for improving speed control and captured energy for variable speed and blade pitch wind turbine.

This paper presents a dynamic model of a variable speed wind turbine using torque and blade-pitch

fuzzy control. Simulation results show the robustness of the fuzzy controller. Soft and nonlinear control actions of this controller can improve the wind turbine performance at low, rated and high wind speed. The wind speed information has been used to improve the speed control in high wind speed and also captured power has been increased. The presented model is going to be implemented using a programmable logic controller as the fuzzy controller designed. Experimental results are expected to agree satisfactorily thus showing the robustness of the fuzzy controllers.

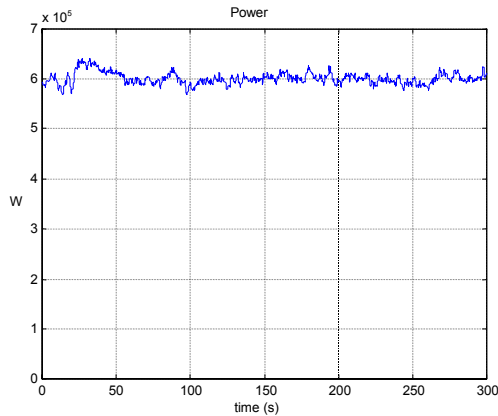

Fig.6. Generator Power for the rated wind time series of the PI Control System

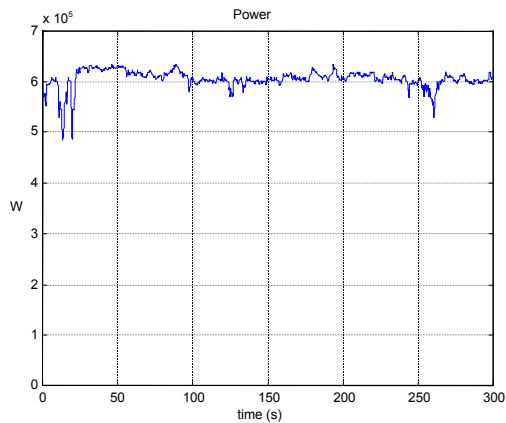

Fig.7. Generator Power for the rated wind time series of the Fuzzy Control System

20m/s	PI	Fuzzy
Energy (kWh)	50.066	50.465
Max. Rotor Speed (rpm)	1602	1585

Table I. Simulation results at high wind speed (20m/s average value)

References

- [1] O. Carlson, J. Hylander, K. Thorborg. "Survey of variable speed operation of wind turbines". EUWEC'96, Göteborg, Sweden, 1996.
- [2] E. Muljadi, K. Pierce, P. Migliore. "Control Strategy for Variable - Speed, Stall - Regulated Wind Turbines". American Controls Conference Philadelphia, 1998.
- [3] M.A.M. Prats, J.M. Carrasco, E. Galván, J.A. Sánchez, L.G. Franquelo, C. Batista. "Improving transition between power optimization and power limitation of variable speed, variable pitch wind turbines using fuzzy control techniques". IECON 2000, Nagoya, Japón, October 2000.
- [4] K. Pierce. "Control Method for Improved Energy Capture below Rated Power". 3rd ASME/JSME Joint Fluids Engineering Conference, San Francisco, California, 1999.
- [5] Siegfried Heier. "Grid Integration of Wind Energy Conversion Systems". John Wiley & Sons, 1998.
- [6] Dave Misir, Heidar a. Malki, Guanrong Chen. "Design and analysis of a fuzzy proportional-integral-derivative controller". Fuzzy set and Systems,79, 1996.
- [7] Wladyslaw Mielczarski. "Fuzzy Logic Techniques in Power Systems". Physica - Verlag, 1998.
- [8] Yifan Tang, Longya Xu. "Fuzzy Logic Application for Intelligent Control of a Variable Speed Drive" IEEE Transactions on Energy Conversion, Vol.9, No. 4, December 1994.
- [9] K. Hirota. "Industrial Applications of Fuzzy Technology". Physica - Verlag, 1993.
- [10] M. Maureen Hand, Mark J. Balas. "Non linear and linear model based controller design for variable - speed wind turbines". 3rd ASME/JSME Joint Fluids Engineering Conference, San Francisco, California, 1999.
- [10] C. Batista, M.A.M. Prats, J.M Carrasco, E. Galván, J.A Sánchez. "Fuzzy Logic Application for Improving Captured Energy for Variable Speed and Blade Pitch wind Turbines". Power Electronics Inteligent Motion Power Quality PCIM'2001, Nuremberg, Germany, June 2001