

ASITRON: ASIC FOR INDIRECT VECTOR CONTROL OF INDUCTION MOTORS WITH FUZZY LOGIC BASED SPEED REGULATION

J.L. Mora, F. Barrero, E. Galván, F. Colodro, J.N. Tombs, M. Barranco*, A. Torralba and L.G. Franquelo.

Dpto. de Ingeniería Electrónica, Escuela Superior de Ingenieros,
Camino de los Descubrimientos s/n, 41092, Sevilla (SPAIN)

e-mail: mora@gte.esi.us.es

(*) Dpto I+D Mecanismos y Accesorios, MACPUARSA.

Abstract

This paper presents ASITRON, an integrated solution for the vector control of induction motors. This ASIC is a micro-system that integrates, in a chip, all the logic required by the indirect vector control method. ASITRON implements a PWM based current control loop, the measure of speed based on a biphas pulse signal encoder, a fuzzy logic based speed and position outer control loop and a microprocessor external parallel interface. A built-in 64-rules fuzzy logic controller can be programmed to deal with the speed or position outer control loop. This integrated solution is the essential part of a compact, high performance, industrial control system for elevators.

1. Introduction

In the past, dc motors were used extensively in areas where variable speed operation was required, since the field and the armature current could easily control torque and flux. In particular the separately excited dc motors have been used mainly for applications that require fast response and four-quadrant operation with high performance near zero speed. However, dc motors have certain disadvantages due to the presence of the commutator and brushes. They require a periodic maintenance and cannot be used in corrosive or explosive environments, and they have limited commutation capability under high-speed, high-voltage operational conditions. These problems can be overcome by the application of ac motors, which have a simple and rugged structure, high maintainability and they are economical, robust and immune to heavy overloading. Their small size compared with dc motors allows ac motors to be designed with substantially higher output ratings for low weight and low rotating mass.

The induction motor is a complex, non-linear system, with time-varying parameters. The dynamic performance of an ac machine is somewhat complex because of the coupling

effect between the stator and the rotor phases, where the coupling coefficients vary with the rotor position, [1], [2]. The conventional voltage/frequency control methods are being replaced by modern vector control. Vector control methods have been proposed to simplify the speed control of induction motors so they can be controlled as a separately excited dc machine. This control method employs two serial controllers, an inner control loop that regulates the current and an external one to control the speed of the drive. Furthermore, this control strategy requires an exact information of the rotor flux vector and instantaneous and accurate adjustment of the actual stator currents to their references. Vector control techniques have been developed considerably over the last twenty years and have become a somewhat standard in induction motor drives. Due to its simplicity, indirect vector control methods have gained more widespread application. These control strategies uncouple the motor current components by estimating the slip speed ω_{sl} , which requires a proper knowledge of the rotor time constant, τ_r . Direct vector control methods require flux sensors or a flux model of the system. For the various vector-controlled drives it is necessary to know different electrical parameters of the machine subjected to vector control. The vector control is highly dependent on machine parameters and this drawback induces the need to use robust controllers. Several methods have been proposed, just as adaptive controllers, sliding-mode techniques and fuzzy control.

Fuzzy-logic, first proposed by L.A. Zadeh, has recently received a great deal of attention. The easy way of defining a fuzzy controller by rules with an obvious physical meaning has helped to expand this control technique. When it is applied to control non-linear systems, including electronics drives, this non-linear control strategy has shown better results than classical controllers do providing robustness against changes in the motor parameters and external

disturbances. One of the major problems of fuzzy-vector controllers is the physical implementation. Generally, this control requires the use of powerful computation systems, such as DSPs.

In elevator industry, motors are used in a particular way. The motor is operated from zero speed to nominal positive or negative speed and then put back to zero, while positive or negative torque loads are applied. Historically, dc-motors were used extensively in high performance systems for elevators, however, for all that has been outlined, a elevator system based on an ac-motor is a better solution for its low cost and low maintenance requirements. The only drawback is the increase in control complexity for the same performance requirements. This paper presents ASITRON an integrated approach to fuzzy-vector control of induction machines that allows to implement the high performance control system required in elevator ac-drives applications in a compact, non expensive way.

2. Description of the Integrated Circuit

ASITRON integrates the indirect vector control algorithm, a digital tachometer, a fuzzy-logic based controller for speed and position regulation, a PWM based current controller and a set of external interfaces, such as A/D converters for current and voltage measurements and a microprocessor parallel interface. Figure 1 depicts a block diagram of a typical ac-drive control system. The basic tasks developed in ASITRON are shown in figure 1. They can be enumerated as follows:

- A. External Interface: Current and Voltage measurement and microprocessor interface.
- B. Indirect field oriented control.
 1. Inner current control loop, including a PWM signal generator.
 2. Speed and position measurement by means of a built-in digital tachometer [9] [10].
 3. Outer speed and position control loop with a fuzzy-logic based controller.
- C. Integrated alarms to evaluate normal function of the system.

ASITRON can be programmed in different ways. For the current control loop it can be programmed to function as a 3-phase PWM voltage generator or as 3-phase PWM current generator while for the speed control loop three options exist: a voltage-frequency controller, a vector control of induction motor and a speed fuzzy controller.

A. External interface.

To measure stator currents and close the inner control loop three 10-bit A/D converters have been integrated on the chip. Therefore, to program the inner registers of the ASIC, it includes a parallel 8 bits bus interface compatible with the ST9 SGS-Thomson processor. The ASIC has 53 registers of variable number of bits (from 1 to 16) and 256 registers of 12 bits in an inner RAM.

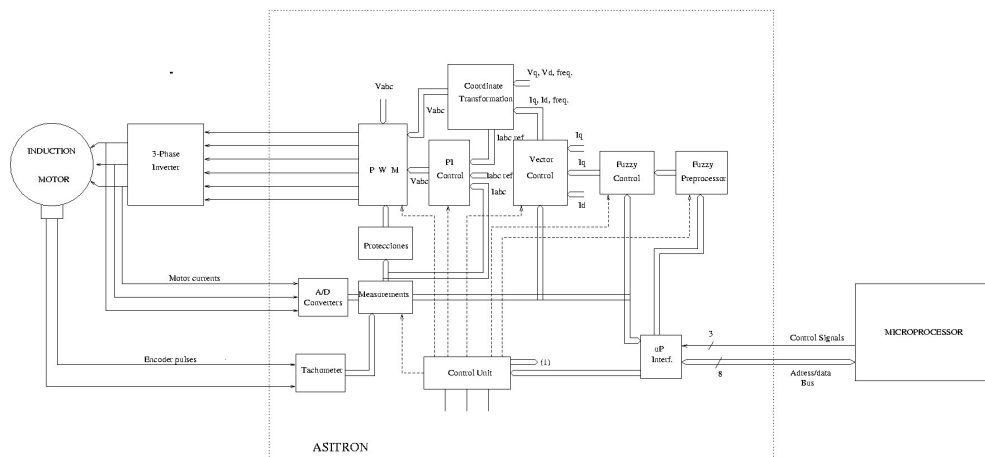

Figure 1. Block diagram of a typical ac-drive control system.

corresponding to the fuzzy sets A_i , B_i and C_i respectively and μ_{D_i} is a singleton membership function associated to the fuzzy set D_i . The rules are stored (up to 63) in a built-in RAM.

In this ASIC, fuzzy implication uses the product operation rule. The connective *and* is implemented by means of the minimum. Fuzzy rules are combined by means of the sentence connective *also* which is implemented by means of the algebraic addition. With this selection of parameters of the fuzzy system, an expression for rule i implication (4) is given by:

$$\mu_{D_i} = (\min_{\text{antecedents}} \mu_{A_i} x_i) \mu_{D_i} = \phi_i \mu_{D_i} \quad (5)$$

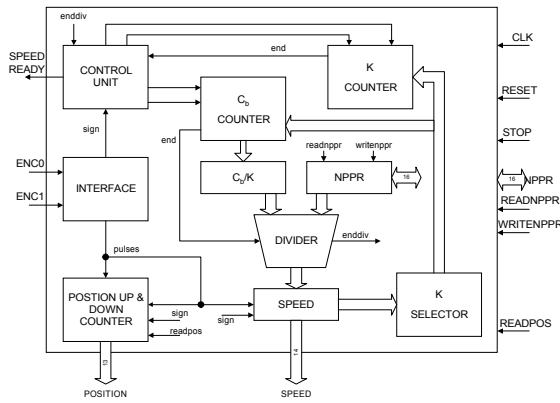

Figure 3. Digital speed tachometer block diagram.

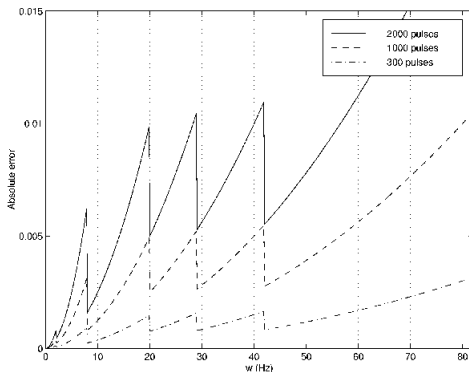

figure 4. Absolute error and conversion time.

Defuzzification is carried out through the centroid method, which generates the centre of gravity of the membership function of the output set. As the membership functions that define the linguistic terms of the output variable are singletons, the centre of gravity of the inferred fuzzy set can be obtained by means of the following expression:

$$u_{fz} = \frac{\sum_1^m \phi_i w_i}{\sum_1^m w_i} \quad (6)$$

where m is the number of rules.

One feature of the implemented fuzzy controller is the singleton auto-learning capability. This feature is based on the least means square technique. For each iteration of the algorithm, the inputs are processed to obtain the output y . The desired output y_d is subtracted from y and this error ξ is used for singletons updated by means of:

$$\Delta w_j = \eta \phi_j \xi \quad (7)$$

$$\phi_j = \frac{w_j}{\sum_0^{m-1} w_i} \quad (8)$$

The fuzzy controller has been designed to process rules sequentially using simultaneous fuzzification and defuzzification with 10 bits resolution for inputs and output.

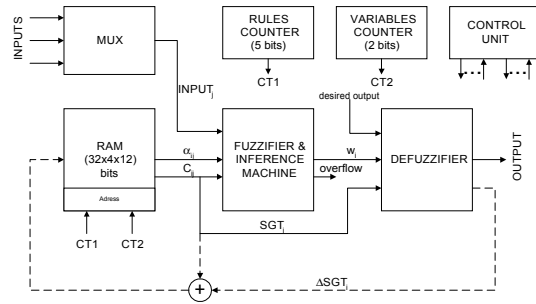

Figure 5. Block diagram of the fuzzy controller.

C. Integrated alarms.

The ASIC has been programmed to avoid undesired operating conditions. Stator currents are monitored to fire alarms if one of the following cases is detected:

- Maximum phase current.
- Minimum phase current.
- Maximum absolute value difference between phase currents.

Alarm values are user programmable.

In addition, a watchdog timer circuitry has been included in the ASIC to prevent it to work when outer microprocessor has failures.

3. Experimental Results

In Figure 6 the motor is operated from low speed to nominal speed and, then, put back to

low speed without load torque. Mechanical speed and motor currents are shown. Note that the command speed has an 'S' form, as usually in vertical operation systems. The reason for this kind of command speed is that soft accelerations or decelerations avoid abrupt movements in the elevator cabin, so the comfort level is increased. The response of the motor when rated speed step is applied is shown in Figure 7. In Figure 8 a rated torque step is applied when the motor speed is 25Hz.

These results have been obtained with the 10kW ac-motor test-rig showed in Figure 9 connected to the ASITRON ac-drive system (Figure 10). ASITRON has been programmed to perform a fuzzy logic based speed regulation with indirect vector control. Currents has been controlled with a PWM at 10kHz.

4. Conclusions

In this paper, it is presented ASITRON, a highly programmable chip that implements indirect vector control of 3-phase ac-machines with application in elevator system.

It can be programmed to perform 3-phase PWM current (voltage) generator, a classical voltage-frequency controller or to implement a modern vectorial control of the induction motor with a fuzzy-logic based speed and position regulation.

ASITRON has been fabricated using a 0.7 μm CMOS digital technology. Figure 11 shows a photography of the final chip.

Presently, ASITRON is the core of a high-performance ac-drive for elevators; the first industrial units were scheduled for December 97 and many units are working today with excellent results.

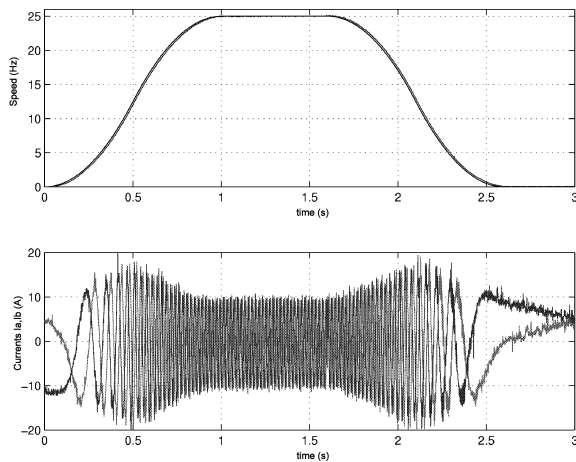

Figure 6. Speed acceleration and deceleration

following a 'S' reference curve without load torque.

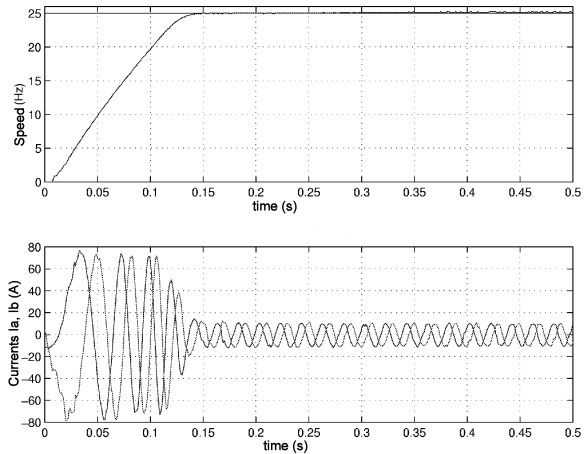

Figure 7. Rated speed step response without load torque.

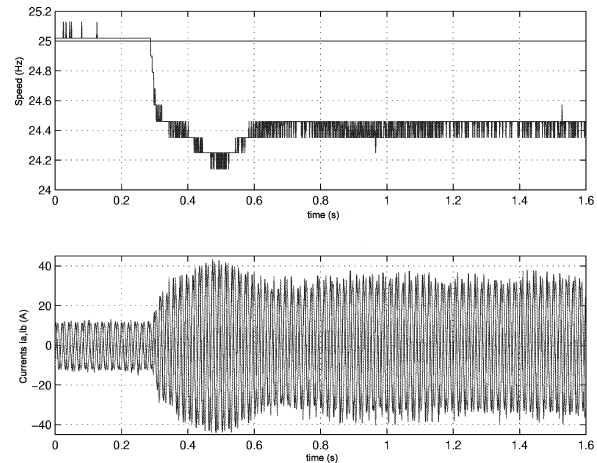

Figure 8. Rated torque step at rated speed response.

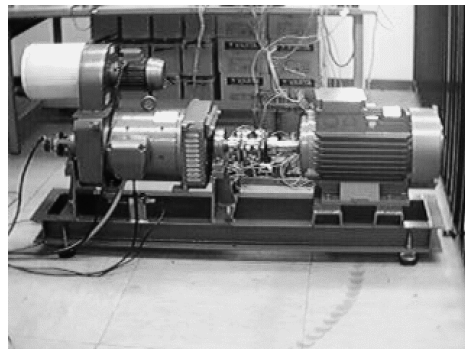

Figure 9. Ac-motor test-rig.

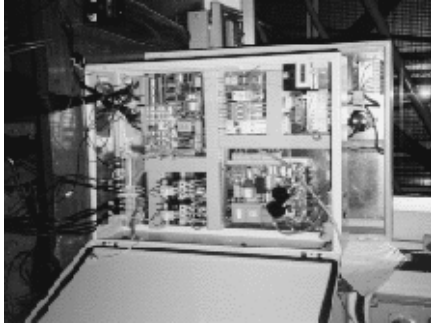

Figure 10. ASITRON ac-drive for elevator.

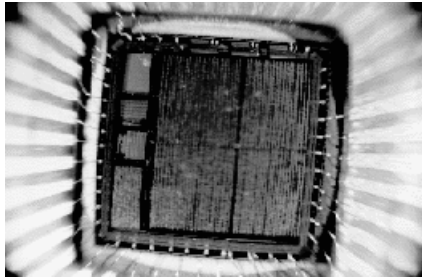

Figure 11. Photography of ASITRON.

[11] **Ichiro Miki, Tatsuo Kumano, Tetsuo Yamada**, "Auto - Tuning Method Based on Fuzzy Reasoning for Speed Controller in Vector -Controlled Induction Motor Drives", IAS - 93 Annual Meeting, pp 718 -727, Toronto 1993.

[12] **Amin Suyitno, J. Fujikawa, H. Kobayashi, Yasuhiko Dote**, "Variable -Structired Robust Controller by Fuzzy Logic for Servomotors", IEEE Transactions on Industrial Electronics, Vol. 40, No. 1, Feb 1993.

5. References

- [1] **B.K. Bose**, "Power Electronic and AC Drives", Prentice-Hall Englewood Cliffs, N.J., 1987.
- [2] **P.Vas**, "Vector Control of AC Machines", Clarendon Press, Oxford, 1990.
- [3] **E.Galván, A.Torralba, L.G.Franquelo**, "Asic Implementation of a Digital Tachometer whit High Precision in a Wide Speed Range", IEEE Trans. Ind. Electronics, vol.43, n.6, pp-661, Dec.1996.
- [4] **V.R.Stefanovic and R.M.Nelms**, IEEE Industry Applications Society, Toronto, October 1993.
- [5] **M.Prokin**. "Extremely wide range speed measurement using a double-buffered method". IEEE Trans On Industrial Electronics, Vol.41, n.5, pp.550-559. October 1994.
- [6] **F.Barrero, J.L.Mora, E.Galván, R.Millán, J.V.Torrellas, L.G.Franquelo**, "FPGA Implementation of a Digital Tachometer for Angular Position and Speed Measurement". European Power Electronics Conference, 1999, to be held in Laussane, Switzerland.
- [7] **Toshiaki Kudor, Kazufumi Ishihara, Haruo Naitoh**, "Self -Commissioning for Vector Controlled Induction Motors", IAS-93 Annual Meeting, pp 528-535, Toronto 1993.
- [8] **Sayed A. Mir, Donald S. Zinger, Malik E. Elbuluk**, "Fuzzy Implementation of Self Control of Induction Machines". IAS -93 Annual Meeting, pp 710 -717, Toronto 1993.
- [9] **E. Galván, F. Barrero, M. A. Aguirre, A. Torralba, L. G. Franquelo**, "A Robust Speed Control of AC Motor Drives based on Fuzzy Reasoning", IAS-93 Annual Meeting, pp 2055 -2058, Toronto 1993.
- [10] **F.Barrero, E.Galván, A.Torralba, L.G.Franquelo**, "Fuzzy Selftuning System for Induction Motor controllers", European Power Electronics Conference, Seville, Spain, September 1995.