



# The Effect of Electrical Current on the Crystalline Lens\*

HERBERT WIESINGER, M.D.

*Clinical Professor of Ophthalmology, Medical College of Virginia,  
Health Sciences Division of Virginia Commonwealth University,  
Richmond, Virginia*

Development of lenticular opacities from lighting was first described by St. Ives (21) in 1722. Even today cataract formation by this mode is a rarity. However, the development of cataracts from accidental exposure to artificially generated electricity has become more frequent and has assumed some medico-legal importance. Cataract secondary to artificially generated electrical current was first described by Desbrieres and Bargy (6) in 1905. Since that time numerous cases have been reported in the literature. The nature of the current producing cataracts varied. However, alternating current of 50 to 60 cycles per second was responsible for the majority of cataracts detailed in the literature. Since all cases resulted from accidental contact with a commercial power source, amperage would seem to be high while voltage varied considerably from 60,000 v in a case of Becker (1) to 220 v by Cavka (3), Horton (11), and Godtfredsen (8). The extent and the severity of the injury in many instances was not related to the voltage. However, data on exposure time are sparse and often unreliable so that the total amount of electrical energy received is, in most instances, a matter of speculation only. An excellent summary of the cases described in the literature up to 1961 is provided by Long (19). Since then a number of additional case reports have appeared in the literature reporting cataractous changes following accidental exposure from 240 to 5,000 v (18, 9, 17, 12, 14). The case of Klima (14) and co-workers is interesting as the accident caused severe bilateral iritis followed by typical electrical

cataracts with no visible burn anywhere on the body surface. Koskenoja and Runeberg (15) were sufficiently concerned about the problem of electrical cataracts to examine 237 psychiatric patients who had received up to several hundred therapeutic shock treatments, but they did not discover any traumatic lens changes in this group.

The experimental production of electrical cataracts in animals was first successfully attempted by Hess (10) in 1888. He subjected rabbits and cats to multiple electrical discharges (6 to 20) at short intervals from Leyden jars in the head region close to the eye. He observed miosis, anemia of the iris, conjunctival chemosis, and corneal opacification. Lens opacities were observed by him in enucleated eyes as early as 2 to 4 hours after exposure.

These experiments were repeated in 1900 by Kiribuchi (13) who produced reversible lens opacities after 30 to 50 shocks of 1-second duration using a voltage of 70 to 160 v. Similar experiments were conducted by Kuwabara (16), Pastega (20), Frese (7), and Croci (5). The latter produced opacities in 7 of 20 animals using a power source producing 10,000 to 100,000 v with a very low amperage.

In 1936, Comberg (4) attempted to clarify if electrical cataracts are caused by iritis or if they are the result of direct passage of electrical current through the lens. He placed electrodes on the anterior pole of the cornea and the posterior pole of the proptosed globe and used multiple (up to 60) discharges from Leyden jars as a power source. Fourteen of 15 animals shocked by this technique developed lenticular opacities. In 7 animals the

\* This study was sponsored by the Medical Department of Reynolds Metals Company, Inc., Richmond, Virginia.

opacities progressed over the observation period, in 5 instances they remained stationary, while in 2 animals the cataracts regressed. He could observe such opacities as early as 30 minutes after shocking which led him to believe that the electric current itself, rather than the anterior uveitis, was responsible for the lens changes.

Bellows and Chinn (2) noted that isolated beef lenses subjected to high voltage current showed a marked decrease in water uptake when immersed in distilled water. They speculated on the possibility of an injury to the lens epithelial cells being responsible for the reduced swelling of exposed lenses; however, they did not reach any definite conclusions as to the mechanism of the production of electrical cataracts.

An excellent experimental study to determine the amount of energy necessary to produce electrical cataracts was described in 1963 by Long (19). He exposed proptosed rabbit eyes to 200 shocks of .2 seconds each at intervals of 4 seconds using a 50 v alternating current. Total exposure time was 40 seconds, and total energy delivered to the eye was 50 times .1466 a or 7.25 watt-seconds for a total of 291 watt-seconds. The slightest amount of current in his experiment to produce minimal cataractous changes was 100 shocks of .25 second at 14 v, representing a total energy of 50.7 watt-seconds. Long (19) also gives an excellent description of the clinical and histological appearance of the experimental lens opacities.

We were prompted in this study by the fact that all previous experimental studies used a multiple repetitive shocking arrangement, something which would be unlikely to occur in any type of industrial or household accident. The aim of this study was to produce lenticular opacities by a single electrical shock of short duration such as is most commonly seen in accidental contact with electrical current. By keeping the exposure time short, the thermal effect upon the eye from electricity was avoided. Survival rate of the animals was acceptable up to 500 v shocks. Anterior segment uveitis was minimal lasting only from several hours to three days, and corneal opacities were extremely rare when resistance was kept low by keeping the shaved lower lid of the globe adequately moistened with normal saline. Physiology was preserved by maintaining the globe in situ rather than using a proptosing device.

**Experimental Apparatus.** In order to study the effects of single electrical shock upon rabbit

lenses, a pulse variable voltage source was built. This is operated on 120 v AC, 60 Hz and has a 0 to 120 v variable transformer connected across the primary of a 120 to 560 v center-tapped step-up transformer. The separate windings of the primary and secondary of this transformer provide isolation of the output circuits from the power line. Either of two output ranges, 0 to 280 v or 0 to 560 v, may be selected by a switch which also determines the appropriate scale on the 0 to 300 and 0 to 600 v RMS voltmeter. The duration of the pulse is preset on an interval timer with manual reset and has a range of 0 to 6 seconds. It is initiated by a push-button operated relay. Pulse current, as well as pulse duration, are measured across a 10 ohm .5% shunt in series with the output circuit. Leads with clip-on connectors are used for making contact to the experimental animal. Pulse current and time are measured with the Tectronex type 549 storage oscilloscope which is calibrated to 100 ma peak current per centimeter on vertical sweep and 100 msec per centimeter on the horizontal sweep. The unit is housed in a metal cabinet with the voltmeter, timer, and controls on a sloped front panel which has provisions for plugging in the oscilloscope and clip-on leads. The cabinet is grounded (fig. 7).

**Lens Changes Following Electroshock.** Mature Dutch rabbits weighing from 1,600 to 2,500 g were used for all experiments. The earliest changes were observed beneath the anterior capsule consisting of an accentuation of the rabbit lens vertical suture line. The area around the sutures assumed a feathery outline thus making the vertical sutures stand out more clearly (figs. 1 and 2). As this feathery appear-



Fig. 1—Accentuation and feathery appearance of anterior suture line.

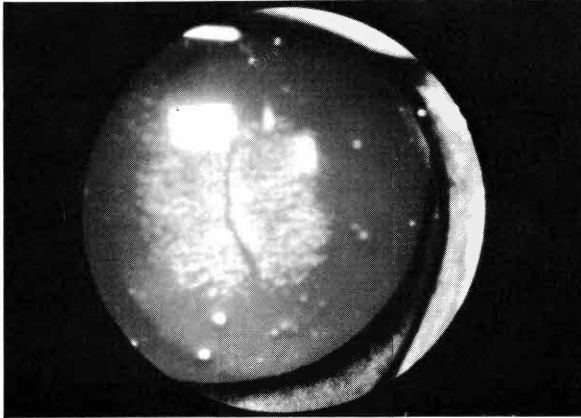

Fig. 2—Feathery appearance of suture line and anterior vacuoles.

ance diminished, there appeared a large number of anterior subcapsular vacuoles in the same area, often clustered around the suture line. These vacuoles, in most instances, increased in number up to two weeks after the shock. Following this in the low amperage shock, they became stationary and very seldom regressed so that there was only an occasional anterior vacuole visible (figs. 3 and 4). In the more heavily shocked animals after two weeks, the vacuoles were gradually replaced by superficial ring-shaped, scale-like opacities. The density of the opacities increased for about four weeks, after which time the opacities showed little or no change over the observation period of four months (figs. 5 and 6). Contrary to the findings of Long, no changes were observed in our experiments in the posterior capsule, and in no instance did any of the opacities



Fig. 3—Cluster of anterior subcapsular vacuoles.

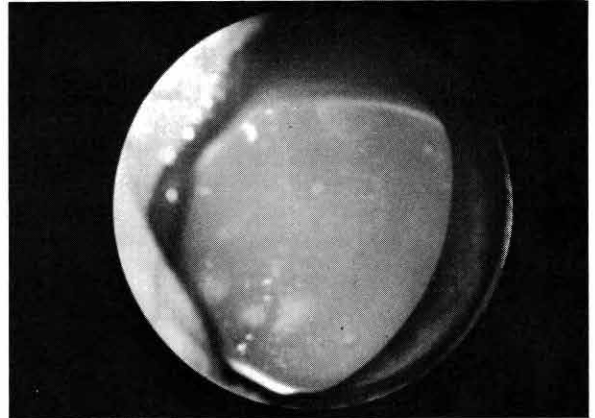

Fig. 4—Anterior subcapsular vacuoles replacing feathery opacity.

progress to involve more than the immediate anterior subcapsular area.

Long (19) reported lens changes by his multiple shock technique with an average of 291 watt-seconds. The slightest exposure to produce such changes was given by him as 50.7 watt-seconds.

In total, 32 animals were shocked in our experiments with exposure times ranging from 100 to 400 msec and voltages of 150 to 500 v AC. Peak amperage as read on the storage oscilloscope varied from a high of 900 ma to a low of 100 ma. The peak amperage was converted to RMS amperage by multiplication with a .707 factor.

Twenty-six of the animals survived for the observation time and are summarized in our findings. Total power applied to each eye was calculated as watt-seconds. It appeared from a tabulation of the

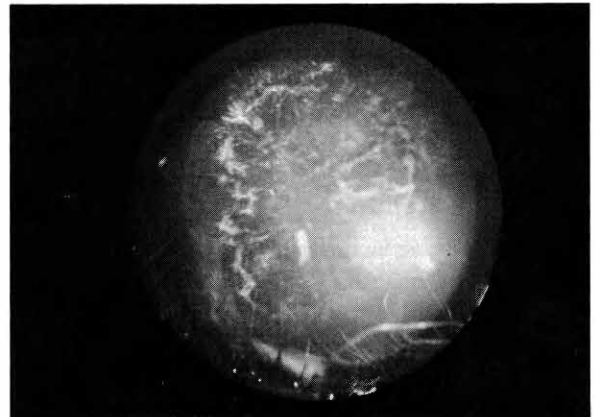

Fig. 5—Cataracta electrica in animal receiving 26.51 watt-seconds.

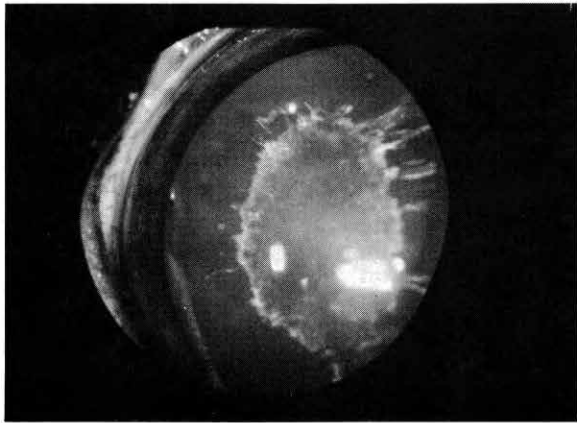

Fig. 6—Cataracta electrica in animal receiving 61.86 watt-seconds.

results that only the total amount of energy delivered was significant in terms of the extent of the opacities developed. Results were divided into three groups. In the first group no biomicroscopically visible changes were observed. In the second group minimal changes consisting of anterior suture feathering, with or without anterior subcapsular vacuoles, occurred which either regressed or remained stationary. The third group developed a typical anterior scale-like opacity covering variable parts of the lens.

*Group I:* Eight animals receiving a single shock of 1.06 to 12.15 watt-seconds developed no visible lens changes.

*Group II:* Ten animals receiving single shock exposures of 6.2 to 26.6 watt-seconds developed minimal lens changes. Eight of these remained sta-

tionary over the observation period while 2 regressed to the point where, after 12 weeks, no changes could be detected by slit lamp examination. The lowest powers with which changes were observed were 6.2 and 7.07 watt-seconds.

*Group III:* Eight animals receiving single shocks of 22.98 to 79.54 watt-seconds developed typical anterior subcapsular lens opacities which involved a major portion of the pupillary area when the eyes were maximally dilated. The data for all animals are summarized in Table 1.

In summary, the cataractogenic properties of electric current were studied. Previous observations dealing with this subject utilized a multiple shock technique—something which is unlikely to occur in any accidental exposure. This study focused on the production of lens changes in rabbit eyes following single exposures of measured electric current. The biomicroscopic characteristics of these changes were described. Minimal lens changes were produced by single shock exposures ranging from 6–26 watt-

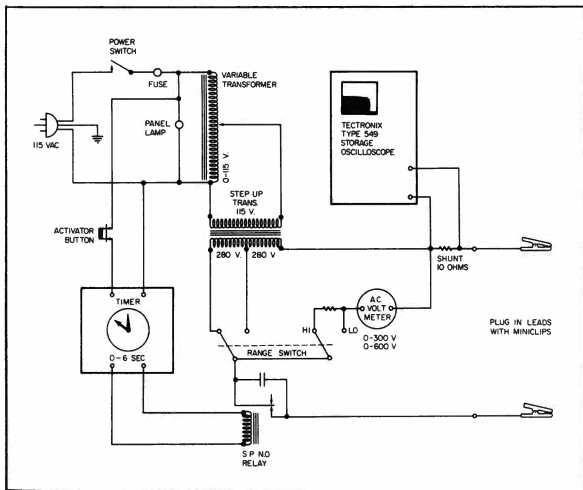

Fig. 7—Wiring diagram of experimental apparatus.

TABLE 1.

WATT/ SECONDS	NEGATIVE	MINIMAL CHANGES	ANTERIOR SCALE CATARACT
1.06	X		
1.60	X		
3.53	X		
3.82	X		
6.10	X		
6.20		X	
6.63	X		
7.07	X		
7.07		X	
7.95		X	
9.20		X	
10.00		X	
12.152	X		
14.1		X	
14.6		X	
15.5		X	
22.98			X
26.3		X	
26.3		X	
26.51			X
27.88			X
30.93			X
33.94			X
35.35			X
61.86			X
79.54			X

seconds while typical electrical cataracts were produced by current of 23–80 watt-seconds. Exposure times were usually 250 msec or less since the survival rate of animals subjected to longer exposures made such studies unfeasible.

*Author's note:* The author acknowledges the technical advice and assistance of Messrs. Raymond Ruffin and Harry Mueller of the Department of Biophysics.

#### REFERENCES

1. BECKER, H. Doppelseitige totale Katarakt und doppelseitiges Quellungsglaukom nach starkem elektrischen Schlag. *Deutsch. Opth. Ges.* 42:234, 1920.
2. BELLOWS, J. G. AND CHINN, H. Pathogenesis of electric cataract. *Arch. Opth.* 26: 606–612, 1941.
3. CAVKA, V. Cataracta electrica cum cyclitide. *Ztsch. Augenh.* 71:156, 1930.
4. COMBERG, W. Das Problem der Cataracta electrica. *Deutsch. Opth. Ges.* 51:132–135, 1936.
5. CROCI, L. Cataracta elettrica sperimentale. *Atti. Cong. Soc. Oftal. Italiana Parma*, p. 3, 1932.
6. DESBRIERES, C. AND BARGY, M. Un cas de cataracte due a une décharge électrique industrielle. *Ann. Ocul.* 133:118, 1905.
7. FRESE, H. Ueber das Spaltlampenbild der Cataracta electrica mit experimentellen Untersuchungen. *Arch. Augenh.* 91:278, 1922.
8. GODTFREDSSEN, E. Cataracta electrica and electrocardiographic changes after electric shock. *Acta Opth.* 20:69, 1942.
9. HANNA, C., FRAUNFELDER, F. T., AND JOHNSTON, G. C. Electrically induced cataract. *Arch. Opth.* 84/2:232, 1970.
10. HESS, C. Experimentelles ueber Blitz Cataract. *Berichte Dtsch. Opth. Ges.* 7:308–317, 1888.
11. HORTON, J. J. A case of electric cataract. *Am. J. Opth.* 9:841, 1926.
12. KAZDAŃ, M. S., Electric cataract. *Canad. J. Opth.* 4/1:104–105, 1967.
13. KIRIBUCHI, K. Experimentelle Untersuchungen ueber cataract und sonstige Augenaffectionen durch Blitzschlag, A. v. Graefe, *Arch. Opth.* 50:1–41, 1900.
14. KLIMA, M., SEBA, J., AND KINDERNAY, S. Poraneni oci elektrickym vy bojem orysokem napeti. *C. S. Oftal.* 24/2:123–126, 1968.
15. KOSKENOJA, M. AND RONEBERG, C. Does electric convulsive therapy cause cataracts? *Acta Opth.* 36/1:102–109, 1958.
16. KUWABARA, T. Zur Pathogenese des Blitzstares. *Arch. Augenh.* 63:1, 1909.
17. LIENSENHOF, H. AND KRAUS, E. Cataracta electrica by Starkstromverletzungen, A. v. Graefe, *Arch. Klin. Exp. Opth.* 175/3:270–282, 1968.
18. LOCK, J. A. N. Cataract produced by a 240 volt current. *Brit. J. Opth.* 41/8:500–501, 1957.
19. LONG, J. C. Electric cataract, a clinical and experimental study. *Am. J. Opth.* 56/1:103–133, 1963.
20. PASTEGA, A. Accidenti da elettricità industriale e loro effetti sull' organismo e specialmente organo visivo. *Ann. Med. Nav. (Colon)*, 2:513, 1910.
21. ST. IVES. Nouveau traité de mal des yeux, 1722, Cited by Duke-Elder, W. S., *Textbook of Ophthalmology*. Vol. 6, St. Louis, C. V. Mosby Co., 1954, p. 6435.