

2008

# MODs: collaboration and play in design

Margaret O'Saben

*Virginia Commonwealth University*

Follow this and additional works at: <http://scholarscompass.vcu.edu/etd>

 Part of the [Art and Design Commons](#)

© The Author

---

Downloaded from

<http://scholarscompass.vcu.edu/etd/1596>

This Thesis is brought to you for free and open access by the Graduate School at VCU Scholars Compass. It has been accepted for inclusion in Theses and Dissertations by an authorized administrator of VCU Scholars Compass. For more information, please contact [libcompass@vcu.edu](mailto:libcompass@vcu.edu).

**MODs:** collaboration and play in design

by: molly o'saben

	table of contents
	acceptance, design manifesto
	introduction
	thesis site
	case study 01: site
	case study 02: site
	case study 03: site
	case study 04: site
	case study 05: process
	case study 06: program
	case study 07: program
	case study 08: program
	case study 09: program
	case study 10: program
	process
	process
	process
	process
	presentation boards
	space allocation
	products
	console table
	thesis documentation
	table of contents
	bibliography

	table of contents	
	acknowledgements, abstract	4
	collaboration and play in design	10
	16 w. broad street, richmond, va; history; light study	18
	le corbusier: house at weissenhof	24
	amsterdam: borneo sporenburg	26
	lazor architecture: flatpak house	30
	eames case study house #8	32
	ray & charles eames	34
	blu dot furniture	50
	ikea	52
	joint connections	54
	european connections	56
	leg godt = play well	58
	mod1	62
	mod2	64
	mod3	68
	mod 3 and mod2 revisited	74
	six	76
	occupants and products	78
	mo design	84
	custom desk	86
	photography	88
	to be continued...	90
	the end	93



# title page

A thesis submitted in partial fulfillment of the requirements for the degree of Master of Interior Environments at Virginia Commonwealth University.

by  
Molly O'Saben  
BFA Craft and Material Studies, Virginia Commonwealth University, August 2006

Virginia Commonwealth University  
Richmond, Virginia  
May 2008

# copyright



© Margaret A. O'Saben 2008  
All Rights Reserved

## design manifesto

*"There will come a time when you believe everything is finished. That will be the beginning."*

*- Louis L'Amour*

I don't believe finishing applies to design. As children we are taught to finish our meals, finish school, and finish our chores. While these lessons are important to our development, finishing is not my goal as a designer. As I work on a design, the first iteration might fulfill the assignment but with each critique inspiration and new ideas unfold challenging me to continue.

I'm fascinated by the lives of Ray and Charles Eames. As a married couple their life revolved around design. It is evident in their work. You can see the time, the collaboration, the *it* that makes something wonderful. They designed their lives, they worked on projects they were passionate about and sustained their lives with that passion. When examining their prototypes, the bent laminated wooden chairs for example, you see a progression from primitive to refined. When Charles was asked about one of his brilliant chair designs he said,

*"it was a flash of inspiration, a kind of 30-year flash."* (DWR)

They weren't interested in finishing, only in developing and improving their ideas. Their genuine interest in their work fostered a lifetime of study, play, and happiness.

Good design requires evolution and evolution is never finished.

## abstract

Located in Richmond, Virginia, MO Design is a small design/build company founded by Molly O'Saben. Ms. O'Saben received her bachelor's degree in Craft & Material Studies and her master's in Interior Environments from Virginia Commonwealth University. MO Design was founded in 2010 with a team of fellow alumni from VCU.

We make objects that inspire inventiveness. Our reconfigurable components offer our clients the unique ability to adapt their environments to life's ever-changing needs.

We make MODs: Make your Own Designs.

Our products are for people who appreciate efficient spaces, are open to exploring possibilities, and like to play. Just as Legos have uniform connections providing a myriad of options for building, our MODs offer the same versatility in a serious adult form. Use our building blocks to make a table, chair, or custom wall unit. When your needs change, dismantle your chair and rebuild it into a bookcase. We make objects that challenge the client to investigate. With exploration of their needs and implementation of their design comes a sense of accomplishment. We want to create this feeling of pride through working hard at play. MODs serve the needs of young and old, differing personalities, multiple demographics and help keep the world green with each reconfiguration.

OUR MISSION: to bring the pride of making back to the individual.

We design, build, and distribute our products. Our company designs components that offer versatility to our customers. MODs are block-like pieces that joint together using tradition mortise and tenon construction. The components we make can be reconfigured like puzzles, providing hours of entertainment for all ages. For our more conservative customers we make MOD PODs: a collection of MODs packaged and sold with assembly instructions to make a specific piece.

MO Design also offers MOD Design Services. We can build a custom office, living room, or children's bedroom with our products based on your unique specifications.

We design to produce options, reduce waste, and create fun in the process. Our clients purchase products based on quality, versatility, and sustainability. Our products challenge how we see furniture – from monolithic, singular objects to dynamic tools for living. Small spaces need flexibility and the proper pieces are essential to an organized environment.

Our products offer the:

- opportunity for individuals to create custom designs.
- ability to customize products without needing expensive, dangerous tools.
- potential for growth with new designs that continue to connect to original parts.
- enhancement of human needs, both physical and emotional.
- excitement of exploration, collaboration, and play.
- versatility to compliment any lifestyle, from highlighted piece to a closet storage system.
- manageability of a product that can be moved and manipulated by a single person.
- a challenge to our current product cycles: buy, use, and discard.

## introduction

What is play? How do adults play? Can adults experience child-like play? Does play require innocence? Is competition play? How do you encourage adults to play?

During the first two years of our lives the entire world is about us and our needs. Between two and three years of age, we discover there are other children around us who feel the same way; and once we get through the compromising and learning to share that make up the “terrible two’s,” we learn something else. There is a thing called play that while entertaining by ourselves, becomes much more enjoyable when a companion’s imagination is added to the mix. The next few years, before play becomes the competitive encounters we adults know, contain some of the most vivid and satisfying sensations that are buried in our psyches—the delightful smells of the outdoors, the ability to “pretend,” the weightless feeling on a swing, the swooping sensation when the car dips down a hill too fast, the reckless, carefree speed of roller skates, the happy feeling when we are pleasantly surprised. Even in the most desperate and unhappy situations, children play. We might be happier if we could remember those joyful days. As adults, we are overwhelmed with responsibilities and the value of innocent play is often forgotten. I want to recreate that feeling in a form that gives adults permission to play.

I had dinner with a friend that I hadn’t seen since high school. After we caught up on past years, I spoke of my current interest—my thesis project. I explained that I wanted to design furniture that grown-ups can construct, as children play with Lincoln Logs or Legos. My companion seemed confused and said, “We speak two different languages.” How could he not understand play? Did he not understand why I would want to study play or not understand the value of play. Either case I find unfortunate. I believe the ability to play adds an important element to our life experience, it’s a time when your mind is free to explore without restraint. In fact, living without play is destructive. Collaborative play performs a vital role in creative development. Quotes like “no one designs in a vacuum,” testify to the importance of collaboration in design.

In the book “Beyond Love and Work, Why Adults Need To Play,” Lenore Terr, M.D. asks the question, “How do we know when we are playing?” She says “people devalue play... in too many middle-class American households today, two adults have to work to support themselves and their family, and leisure time is a luxury. We are spending more money and ending up with less spare time. We are forgetting how to play.” She explains that leisure and play are very different by definition. Leisure is passive, play is active. (Terr)

The Swiss psychologist Jung saw play and work as inseparable; in 1923 he wrote “Without playing with fantasy, no creative work has ever yet come to birth.” In “Two Tramps in Mud-Time,” Robert Frost eloquently wrote:

“My object in living is to unite  
My avocation and my vocation  
As my two eyes make one in sight.”

Scholars have studied play for centuries. Author Roger Caillois, in “The Definition of Play and The Classification of Games” defines play as an activity which is: “free not obligatory, defined and fixed in advance, an undetermined course which cannot be determined, and some latitude for innovations being left to the player’s initiative. Play is unproductive, governed by rules that suspend ordinary laws, and make-believe.”

## introduction

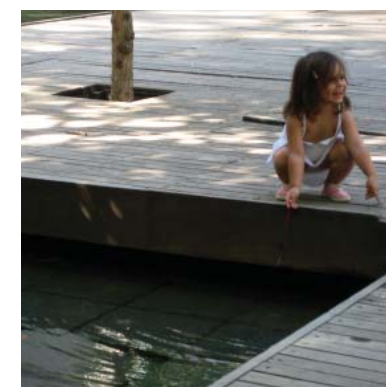
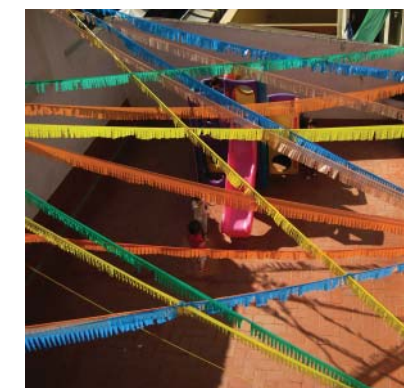

## introduction

### VITRA DESIGN MUSEUM

While playing with my Mennonite friend as a child, I enjoyed the quiet, uncomplicated serenity of their home. One of our favorite things to do was play with a wooden marble set. The toy was simple. We selected a smooth, shiny, multi-colored marble from a trough in the bottom of the wooden structure and placed it at the top. We watched the marble roll down a series of ramps getting louder and louder as it gained speed crashing to an abrupt stop at the bottom. We tried various sizes and weights of marbles, dropping some gently and others forcefully. As an adult I think about the design of the toy but as a child it was simply a pleasure to our senses, the rattling sound, the feel of the smooth marbles, and the movement. Our adult brains work to analyze, but the delight was in the play.

I was reminded of this toy when I visited the Vitra Design Museum located in Weil Am Rhein, Germany in June 2007. Vitra is a European distributor of classic modern furniture. A firehouse on the site designed by Zaha Hadid was exhibiting the work of Ray and Charles Eames. The importance of design in their lives was clearly demonstrated by the hundreds of experimental forms and models they produced to perfect their creations. I was especially interested in a two-story extruded square wood box with a Plexiglas front and dozens of xylophone plates inside that slid out and could be rearranged to produce different tunes. It recalled the joy of playing with that simple marble set. This large toy had a silver ball about an inch in diameter that could either be pumped up from the bottom or dropped from the second story. As the ball descended it struck each plate producing sounds. I was told that new employees at the Eames' firm were given the "job" of rearranging the plates to make a new song. What an effective tool for demonstrating their belief in the importance of play in design!

### ART IMITATES LIFE

The movie "Big," is a fantasy about a boy who was granted his wish to be an adult free to make his own decisions. The transition was terrifying at first, but when given a job at a toy company he charmed the president with his child-like enthusiasm and was given a corner office. The plot of the story demonstrates the contrast between the sophisticated and the naive approach to life. The hero was successful because of his ability to play.

A similar story line in the movie "Elf," was about a child who was rescued from an orphanage and raised by Santa Claus. As an adult, while working with the other elves, the boy discovered that he was human and his real father was alive. He left the North Pole to find his father who was the president of a failing children's book publishing company. The hero restores the city's belief in Santa and writes a playful book that saves his father's business. This boy, like the character in "Big," was an adult whose child-like ability to play enhanced the lives of the other characters.

"The Man Who Saved Christmas," was the fictionalized tale of real-life A. C. Gilbert who invented the erector set and founded the A. C. Gilbert Toy Factory. During WWI, the toy company was asked by the federal government to curtail their toy making production in order to manufacture armaments. The company publicized their intent to postpone Christmas. Children throughout the country responded with letters asking for new toys and for advice about the toys they already had. When Mr. Gilbert realized the negative effect that ignoring Christmas had on the country, he approached Congress and was able to convince them to allow toy production to continue. His speech told how playing

## introduction

**to play** = to engage in sport or recreation;  
**to toy or fiddle around with something**



big kids playing, fao schwarz, new york city, ny

## introduction

with a building set is fun, encourages inventiveness, and opens the door to future creative thinking. These examples illustrate through fiction that recapturing the ability to play can reinvigorate the lives of adults.

### CRAFT

In the late 19th century, the onset of the industrial revolution fostered mass-production. The rise in efficiency while giving success to the proprietor took creativity away from the individual. During the 20th century, the assembly line dominated manufacturing and was utilized by car companies and many other industries. Some jobs once performed by the human hand are now done with computer technology. The downside to this progress is the diminished human involvement in a project from inception to completion that gives a sense of accomplishment. One positive result, could be time available for the enhancement of procedures and design development.

The Arts and Crafts Movement, a British-American aesthetic movement at its height between 1880 and 1910 was a reaction to machine-made production. It promoted turning away from machines and back toward handcraft, but the price for hand made products was high. The movement was not totally anti-industrial nor anti-modern, instead some followers suggested craftsmen could master machines to do their bidding. Artists could use machines to do the mundane tasks but follow the process from beginning to end, make affordable pieces, and not lose their craft talent. (Wikipedia)

The Bauhaus School in Germany was founded to discover a resolution between the contradiction in the processes of mass-production and artisanship. The design profession evolved out of the ideal that it is important to give creativity back to the individual. One way to encourage creative thinking is to provide the time and freedom to explore possibilities--to play. Playing gives you the freedom to explore creative possibilities by stepping outside the parameters. While this may not be possible in all professions, I believe encouraging play could enhance all types of work and the lives of laborers.

While studying craft and materials I enjoyed the processes from design to prototype to the final form. The first step in a project was deciding what I wanted to make. It might be a mirror, a display piece, or a storage system. Once that was decided, I would research existing examples and note the elements essential to the piece. I would draw and make models to illustrate the current pattern and then determine what I could change to make it unique or more efficient. This is the part of design that benefits from play. When I discovered something that was different and changed things for the better, the interest in making the item would intensify to excitement—what the Eameses called “serious fun.” That excitement would carry me through the many failures inherent in reaching a successful answer. The process involved in making the physical object is another level of elation when your ideas and research become three dimensional. As I worked with my prototypes, my studio colleagues would show interest in my design, ask questions, and offer opinions that would often open other avenues of thought and challenge my imagination resulting in an even better form. The culmination of these feelings was pride and satisfaction shared with all those who create with their hands.

In the latter part of the 20th century, the numbers of students going on to higher education rose steadily. This may have caused the decline of interest in learning trade skills from the older generation. Education provided increased income that afforded young adults the ability to hire laborers or buy what they wanted. Life became physically easier, but

## introduction





## introduction

the loss of those skills was a loss of creativity and individuality, similar to the effect of the industrial revolution on artisanship. More importantly, what was lost was the connection to people. While higher wages are a source of some pride, I don't believe items bought commercially can compare to the value of something personally envisioned and created by the human hand. Heirlooms hold personal histories of people and their families with traces of past lives in their patina. Even the definition has appeal: patina—a surface appearance of something grown beautiful, especially with age or use. So how do you make something new that has the potential to become an heirloom? All you have to do is make it, make it well, make it to last, and pass its history on to your descendents. It will develop a life of its own tied to your family history, and perhaps spark an interest among the next generation to carry on that creative skill.

### COLLABORATION AND PLAY IN DESIGN

Collaborative studio work although encouraged in design school, can be distracting. The noise and interruption can interfere with concentration. However, the benefit of working with others has proven to make projects more interesting and thoughtful, far outweighing the negative arguments. Questions that arise during the production of projects can be answered with a myriad of opinions, challenge your thinking, and improve your objective.

Collaborative efforts are common in our society. Governments are more stable when many views are expressed and refined by compromise. Corporations work together, with tiers of management to prevent the dominance of one voice. Relationships are more successful when responsibilities and views are shared. The control of any one person's perspective can result in resentment and dissension from those subdued. In our private lives, couples work together on a daily basis to run a household—cooking, cleaning, maintaining a home, and raising children offers a lifetime of partnership. Relations between people are often sparked by similar interests, hobbies, religion, or profession. There is a tendency for individuals to partner with people in their profession, a natural following to the relationships formed in school or connections made in the workplace.

While researching the couple Ray and Charles Eames I was impressed by some of the work they generated: the lounge chair, their movie "The Powers Of Ten," and their Case Study House. I learned that their accomplishments were the result of years of strong research and development in collaboration with each other, colleagues, and friends. Most articles on the Eames couple mention their successful collaboration, and pictures of them at work clearly demonstrate their enthusiasm and joy at their work and with each other. What makes this couple unique is that their common interests in the field of art and design also enhanced their life process. Because their work was so collaborative and enjoyable the lines between work and leisure were blurred. Charles and Ray approached each project with these simple questions in mind: "Does it interest and intrigue us? Can we make it better? Will we have 'serious fun' doing it?" (Neuhart)

"A playful state of mind applied to work allows for clever solutions to work-related problems and a sense of well-being. Work and play need not be mutually exclusive..." (Terr)

## introduction

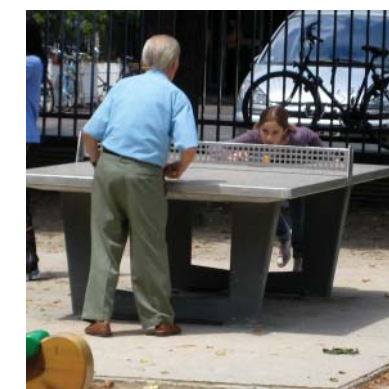
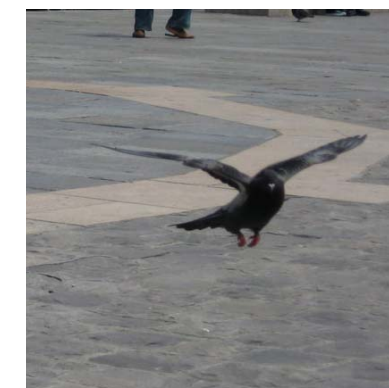
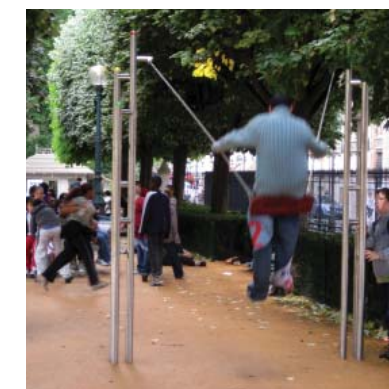
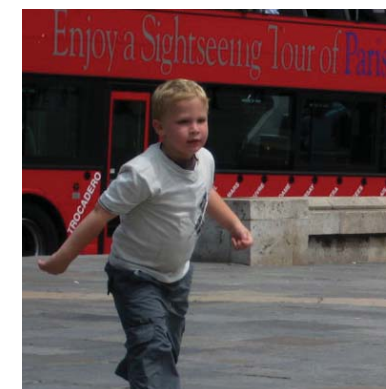

"take your pleasure seriously."

- charles eames

## thesis site

Walter Parks Architecture designed a mixed-use row house located at 16 W Broad Street in Richmond, Virginia. Mr. Parks is the client for the space and Sean Wheeler, the architect/project manager. The parameters given to Mr. Wheeler for the design were simply that there could be no more than seven residential units and one commercial space.

The space is located between two existing buildings in a 120' x 22' space (see image opposite). The retail space, a hat shop in its previous life, occupied only the front third of the lot facing Broad Street. To utilize more of the land the architects decided to demo and start anew leaving behind only a small brick shed in the middle of the lot.

The project broke ground November 2007 and is expected to be finished by the end of 2008. I chose this site to illustrate the various demographics my project attempts to bridge. The commercial space on the first floor is leased to MO Design, the designer and manufacturer of MODs. The seven apartments are rented to various ages and backgrounds:

- APT 101 - senior couple (Ray and Charles Eames);
- APT 201 - young couple with small child;
- APT 202 - young professional male;
- APT 203 - young professional female;
- APT 301 - two female college students;
- APT 302 - established male artist; and
- APT 303 - established professional female.

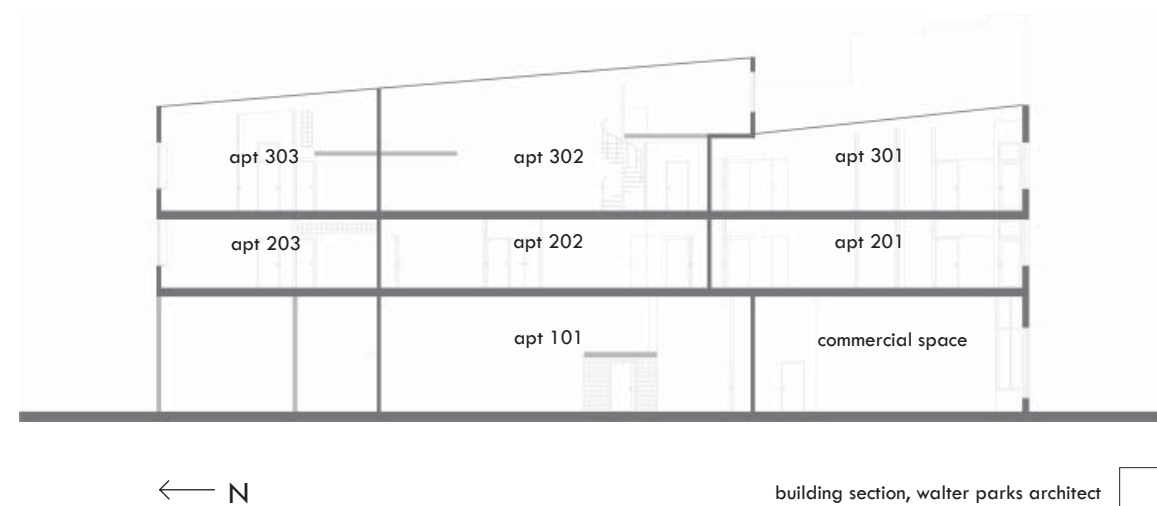

## 16 w broad street, richmond, va



16 w broad street, south facade, rendering by walter parks architect



## thesis site

In the early part of the 20th Century, Richmond had two downtown commercial centers: Broad Street and two blocks south, Main Street. Farmers brought horse-drawn carts filled with fresh produce into the city and sold their goods just north of Broad on Marshall Street. In the early part of the Century, festivals were held with street vendors and Ferris wheels to attract clients. The street car was pioneered in Richmond and was successful in facilitating the transportation of commuters from miles outside the shopping district. (E. Salmon and J. Salmon 77-137)

The stretch of Broad east of Belvidere Street contained two of the leading department stores in Richmond. Thalhimers Brothers and Miller and Rhoads were two commercial anchors of the district who had continued success through most of the 20th Century. Thalhimers was noted for their traditions during the holiday seasons: the Snow Bear who distributed stickers, and **Lego Land**. (Wikipedia)

## history



11 - 17 e. broad street, circa 1900

9



holiday season record-breaking sales, 5th & broad streets, circa 1920s

9

## thesis site

One of the architect's main concerns with this structure was allowing natural light into the interior spaces. The diagrams to the right are studies of the natural light sources at 16 W Broad. The amount of light in this building is substantial considering its inner row house location. The north and south facades are filled with windows and balconies taking advantage of direct and ambient light. The center courtyard flushes the interior spaces with ambient light along with six skylights and two light shafts that penetrate through the top two floors.

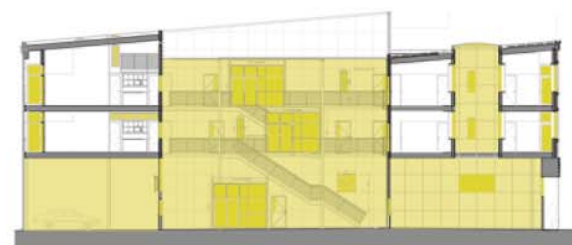
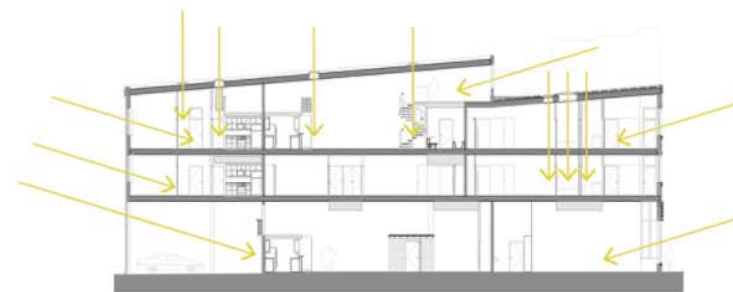

## light study

A similar study was done of The Villa Savoye located in Poissy, France, just outside Paris. Completed in 1929, Le Corbusier used this building to demonstrate his "Five Points of Architecture." One of his plans for the new aesthetic of architecture was an emphasis on windows. Pilotis (steel support columns) placed in a grid pattern throughout the space support the load of the structure allowing the facade to be unobstructed by bulky columns. Horizontal bands of windows wrap the building filling the interior with natural light. The dark yellow denotes exterior windows and the lighter yellow shows where light penetrates into the building from the exterior glazing.

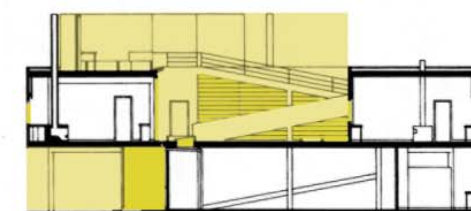
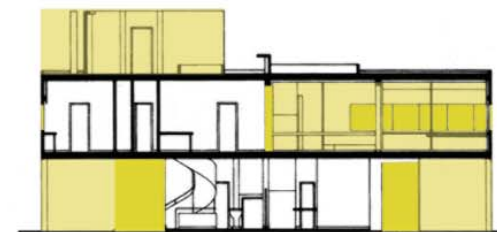
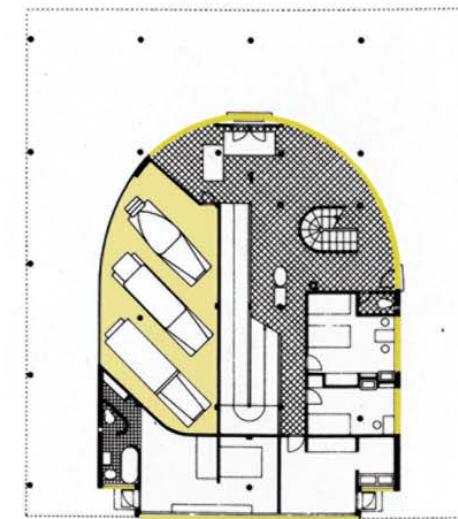

## case study 01: site

The Weissenhof Estate was a project organized by Mies van der Rohe in the early part of the 20th Century. It was built for the Deutscher Werkbund exhibition in 1927 and meant to be a prototype for future workers' post-war housing. The Deutscher Werkbund was a state-sponsored effort to integrate traditional craft and industrial mass-production techniques. The site included 21 buildings housing sixty dwellings. Mies selected 16 prominent architects of the time to build housing that would help solve the housing crisis just after WWI. The budget was meant to be modest and living small was an objective of the program.

Le Corbusier used crude materials in his design: brick, tiles, and plaster. He used his *Le Modulor* design dimensions to determine the size of the duplexes. Lintels were set at 7'6" and spans of 7'6" and 12' were used throughout the building.

Le Corbusier designed two buildings on the estate. The building pictured here was a duplex with one space being the mirror image of the other. The space was versatile with partitions that could open between two rooms for daytime use and be closed at night for privacy. A standard sized storage unit was used throughout the space. There were three in the master bedroom/living area that housed three single beds in the bottom and storage space above. At first glance the units look like ordinary cabinets but closer examination reveals a thoughtful design. This one cabinet design fulfilled multiple uses throughout the house. The mass of the units was in the bedroom/living area but the back of the units could be accessed on the other side of the wall behind the unit, making the depth of the cabinet more useful. This provided additional storage to the bedroom, a linen closet/storage area outside the bedroom, and the kitchen on the opposite side of the house.

## le corbusier: house at weissenhof



duplex in stuttgart, germany



cabinet from front and back



Borneo Sporenburg Aerial View 4

## amsterdam: borneo sporenburg

## case study 02: site

In 1995, the Eastern Docklands of Amsterdam began a transformation from a harbor into a 2,500 dwelling contemporary housing district. The cluster of islands is located in the IJ river. West 8, an urban design and landscape architecture firm in Rotterdam, Netherlands, was given the job of master planning. They were challenge with preserving the harbor structure, giving old buildings new functions, and creating low-rise high-density housing. The result was a canal housing typology that brought the character of the inner city out. West 8 divided the 60 parcels of land that were sold through a lottery. Requests for Proposals were sent to prominent firms around the world asking for submissions. Parameters were given on the number of units, the height and the width of the buildings.

The docklands area was used in the 19th & early 20th centuries to service shipping corporations that traded with the East Indies. In the 1970s, the area was abandoned after a bust in trade. Artists moved into the area to use the abandoned warehouses for studio space. In the 1980s during a housing shortage in Amsterdam, the city regained interest in the area. The challenge of the architects was to preserve the history and character of the region, to blend old and new. A 1920s hostel was transformed into a hotel/cultural embassy. Two warehouses were converted into the top music venues in town. Pols Potten, a ceramics maker, opened its headquarters on an island to the north of Borneo Sporenburg and The Paul Andriese Gallery, one of Amsterdam's most prestigious art dealers, also relocated to the area. (Bergmans 11)



borneo planet 1



townhomes in borneo sporenburg

**“In this tiny country, which is on par with Japan in terms of population density, space has always been at a premium: reclaiming, recycling, and recreating are second nature.”**  
(Bergmans)

## case study 02: site

The SILODAM complex, located on the IJ River, is located next to two former grain warehouses which is where it gets its name. The building is reminiscent of shipping containers paying homage to the site. Housed inside are 157 apartments, business units, and public spaces. The 10-storey building is a conglomeration of pods that vary in orientation and size. The spaces differ in size and color, and the interior walls can be moved and replaced by future inhabitants. The various "houses" are visible from the exterior and recognizable by the colors used in the corridors. (Kiser)

A large balcony located on the west side of the building offers a common area for all residents to share.

Site Area: 2,600 square meters

Building Area: 26,000 square meters

15 different apartment types

Completed: 2002

Client: Vastgoed, De Principaal B.V.

Architects: MVRDV

## amsterdam: borneo sporenburg



silodam, amsterdam 8

## case study 03: site

The FlatPak house is a prefab building constructed in sections of 8' x 8' panels. The architect of the system, Charles Lazor, built the first prototype in Minneapolis, Minnesota as a private residence for his family.

"Flatpak didn't start out as a grand plan," Lazor explains. "It started from my own frustration. Zelda and I wanted a house. We didn't like what was out there. So I started to design a system appropriate to my needs." (Arieff)

The panel system allows customization throughout the building. The client works with Lazor's firm, Lazor Office, to select a variety of panel layouts. Each panel can be broken down into smaller divisions of solids and voids. Solid areas can be filled with metal, wood, or concrete. The voids can be open or filled with clear or frosted windows and doors. The maximum height for the house is four stories but the width is unrestricted.

As co-founder of Blu Dot Furniture, Mr. Lazor, has committed his career to making design accessible. While the price for a flatpak house is not at the low end of the spectrum, it does offer a custom home for a fraction of the custom price.

website: [www.flatpakhouse.com](http://www.flatpakhouse.com)

## lazor architecture: flatpak house

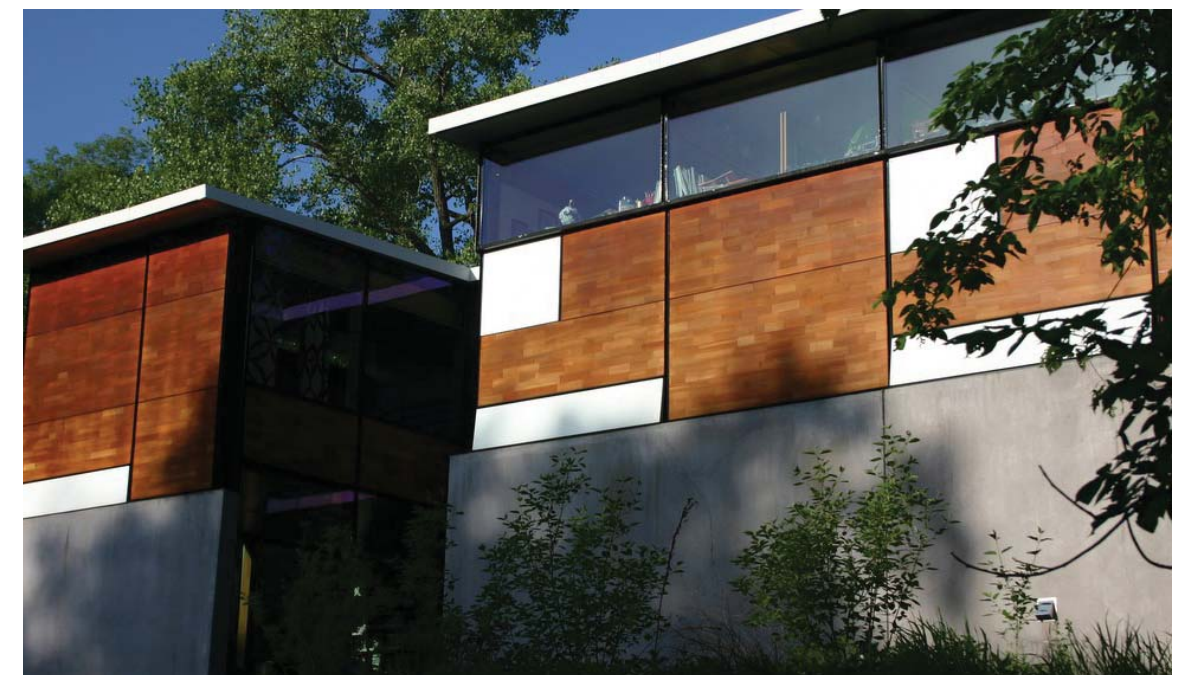

flatpak house, location



front elevation



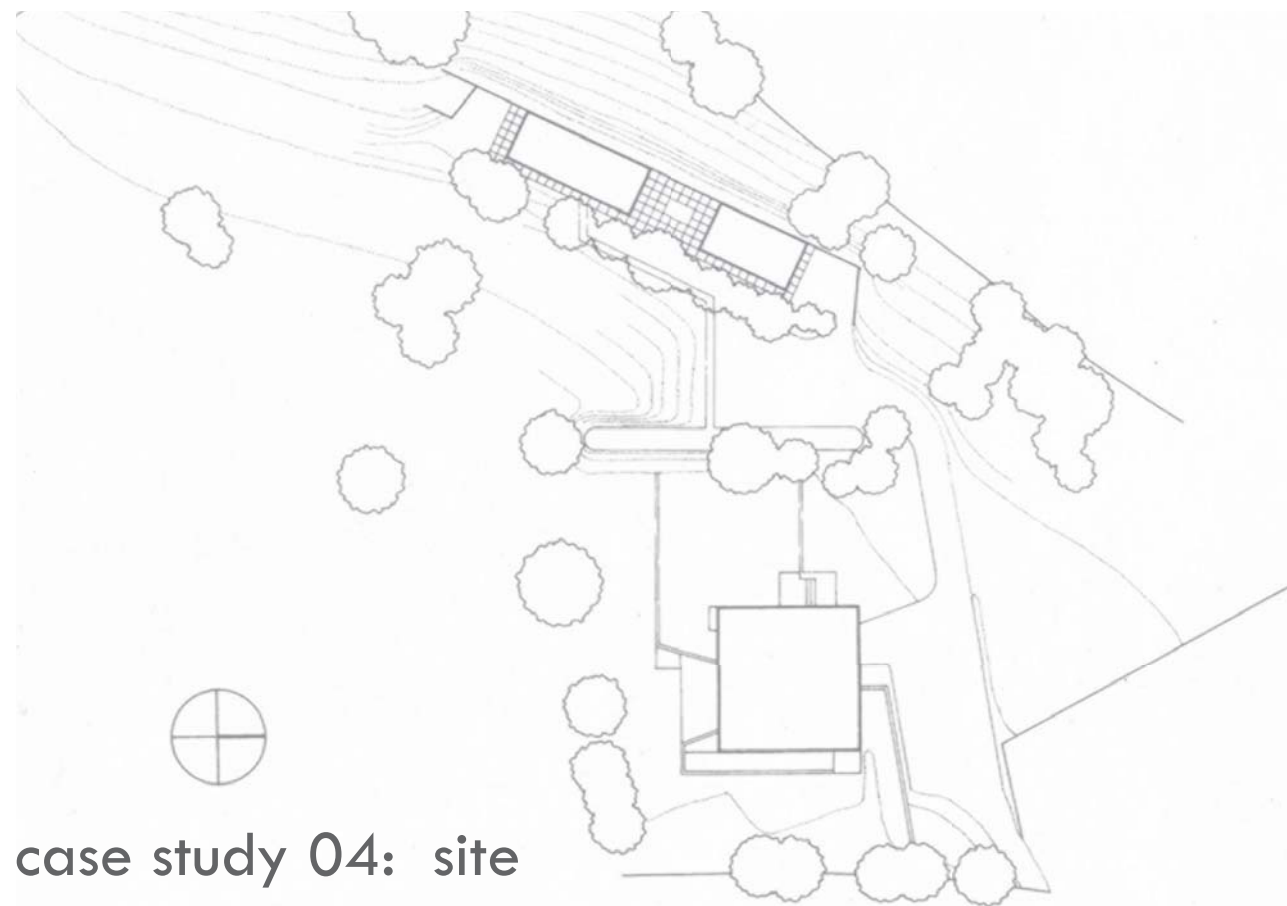

## case study 04: site

The Case Study House Project was organized by editor of Arts and Architecture Magazine, John Entenza. Upon their arrival in California in the 40s, Ray began designing graphics for Entenza's magazine covers.

Entenza approached Charles Eames and several other prominent architects of the time with a proposal for a new housing community in the Pacific Palisades, Los Angeles, California. This community was to be the answer to post-war housing shortages but also was meant to redesign the look and function of home. This program was similar to Ludwig Mies van der Rohe's Weissenhof Estate project in Stuttgart, Germany in the 20s. Entenza and Mies' projects both explored a new aesthetic for housing design with the help of influential modern architects.

In 1945, Charles Eames and Eero Saarinen worked together on the first sketches of Case Study House #8. The house was designed to be made completely from "off-the-shelf" parts available through steel fabricators catalogs. After collaboration between Charles and Ray, the plan for the house changed drastically. The new design nestled into a ridge having little impact on the site and preserving the view of the meadow in front of the home.

A long concrete retaining wall was added to the ridge side of the site. The house featured a mezzanine level with a pre-fabricated spiral stair leading up to the bedrooms. A courtyard was added to separate the residence from their studio space. The exterior of the house was reminiscent of Piet Mondrian's compositions. Mondrian, a prominent Dutch De Stijl painter, said "I believe it is possible that, through horizontal and vertical lines constructed with awareness, but now with calculation, led by high intuition, and brought to harmony and rhythm, these basic forms of beauty, supplemented if necessary by other direct lines or curves, can become a work of art, as strong as it is true." (Wikipedia)

The progress of the Case Study Houses was documented by Arts and Architecture

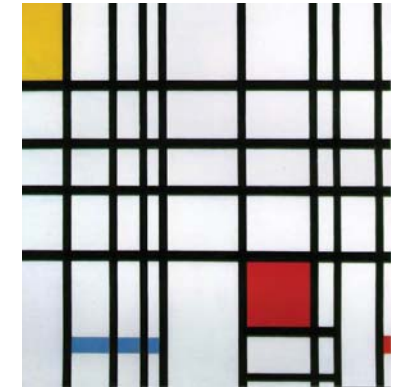

mondrian, composition with yellow, blue, and red, 1921

## eames case study house



case study house #8 6

interior views of case study house #8, published in "houses of the century" 6

## case study 05: process

Ray Kaiser and Charles Eames met at the Cranbrook Academy in the mid-1930's. Ray was trained as a fine artist and studied painting under the renowned artist Hans Hoffman in New York City before attending Cranbrook. Charles was brought to the school by Eiel Saarinen who was the president of the Academy at the time. The couple spent several years studying and teaching at the school. In 1941, the couple married and relocated to California. They soon began work with John Entenza, the editor of "Arts and Architecture" magazine. Ray did graphic design work for the magazine.

The couple transcended many types of media innovating and educating along the way. Their lives are a model of a lifestyle that was dictated by the things that was of genuine interest to them. Satisfaction and pride came from hard work.

The Eameses adventurously pursued new ideas and forms with a sense of "serious fun." Yet, it was rigorous discipline that allowed them to achieve perfection of form and mastery over materials. As Charles noted about the molded plywood chair, "Yes, it was a flash of inspiration," he said, "a kind of 30-year flash." (DWR)

Their molded plywood experiments for mass-producing chairs led to the production of splints and litters for the US Navy during WWII. They used the same techniques to build large-scale gliders and later toys for children.

Towards the end of their lives, the couple spent time educating and exhibiting with their work. In 1969, they exhibited in Paris at the Louvre. The show entitled "What Is Design?" included the Vinn diagram on the previous page as one of the main graphics. It explains their approach not only to the work they did but their lives as a whole. They chose jobs that matched their interests and often a higher goal and viewed success as a collaboration that is meaningful to all participants involved.



ray & charles eames



## case study 05: process

The Eames furniture designs have bases and tops that are interchangeable but this was not for the purpose of mixing and matching. That there are interchangeable bases and other parts has to do with the goal of the Eames Office, which was to offer the best product, at the lowest possible price. Standardized parts, and connecting devices made it easier and more economical for them to offer the best products. (Vintage Eames)

Charles and Ray Eames were 20th Century pioneers. The couple lived their lives as one part celebrating the betterment of society as a whole. Their lives were filled with art, design, architecture and invention. It is apparent in their work that their lives were fulfilled by the study of these things. The mediums they used ranged from wood to metal, paint to plastic, graphics to film. They produced art, furniture, films, toys, books and exhibitions. (Neuhart)

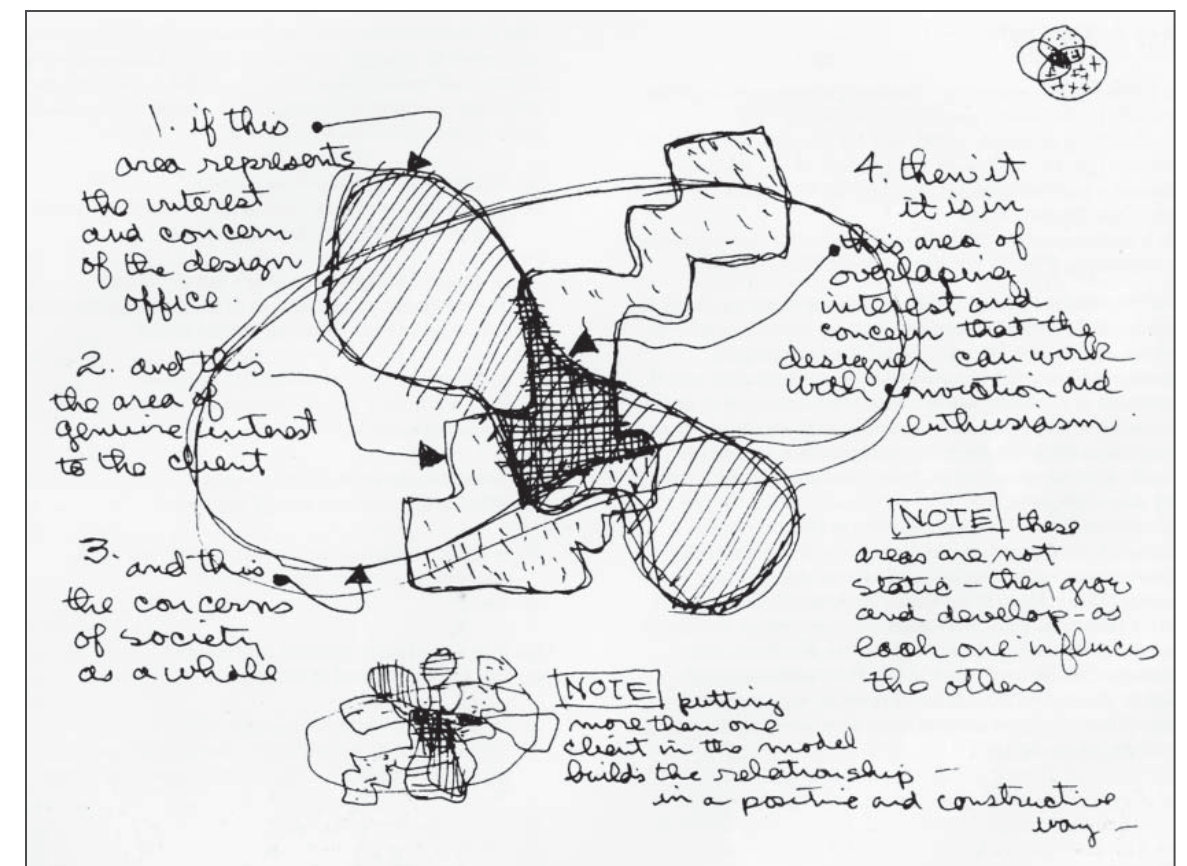

## ray & charles eames

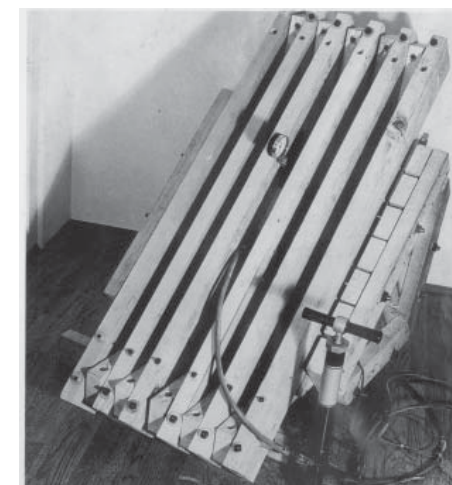



A photograph of Charles taken in 1972 by Paul Bruhwiler



The following questions were asked by Madame Amic and answered by Charles. The questions and answers were the conceptual basis of the exhibition *What is Design?* An edited and slightly changed version of the questions was used as the basis of the 1972 film *Design Q & A* (p. 388).

Q. What is your definition of "design?"

A. A plan for arranging elements in such a way as to best accomplish a particular purpose.

Q. Is design an expression of art (an art form)?

A. The design is an expression of the purpose. It may (if it is good enough) later be judged as art.

Q. Is design a craft for industrial purposes?

A. No—but design may be a solution to some industrial problems.

Q. What are the boundaries of design?

A. What are the boundaries of problems?

Q. Is design a discipline that concerns itself with only one part of the environment?

A. No.

Q. Is it a method of general expression?

A. No—it is a method of action.

Q. Is design a creation of an individual?

A. No—because to be realistic one must always admit the influence of those who have gone before.

Q. ...or a creation of a group?

A. Often.

Q. Is there a design ethic?

A. There are always design constraints and these usually include an ethic.

Q. Does design imply the idea of products that are necessarily useful?

A. Yes—even though the use might be very subtle.

Q. Is it able to cooperate in the creation of works reserved solely for pleasure?

A. Who would say that pleasure is not useful?

Q. Ought form to derive from the analysis of function?

A. The great risk here is that the analysis may not be complete.

Q. Can the computer substitute for the designer?

A. Probably, in some special cases, but usually the computer is an aid to the designer.

Q. Does design imply industrial manufacture?

A. Some designs do and some do not—depending on the nature of the design and the requirements.

Q. Is design an element of industrial policy?

A. Certainly; as is any other aspect of quality, obvious or subtle, of the product. It seems that anything can be an element in policy.

Q. Ought design to care about lowering costs?

A. A product often becomes more useful if the costs are lowered without harming the quality.

Q. Does the creation of design admit constraint?

A. Design depends largely on constraints.

Q. What constraints?

A. The sum of all constraints. Here is one of the few effective keys to the design problem—the ability of the designer to recognize as many of the constraints as possible—his willingness and enthusiasm for working within these constraints—the constraints of price, of size, of strength, balance, of surface, of time, etc.; each problem has its own peculiar list.

Q. Does design obey laws?

A. Aren't constraints enough?

Q. Are there tendencies and schools in design?

A. Yes, but this is more a human frailty than an ideal.

Q. Ought the final product to bear the trademark of the designer? of the research office?

A. In some cases, one may seem appropriate. In some cases, the other, and certainly in some cases, both.

Q. What is the relation of design to the world of fashion (current trends)?

A. The objects of fashion have usually been designed with the particular constraints of fashion in mind.

Q. Is design ephemeral?

A. Some needs are ephemeral. Most designs are ephemeral.

Q. Ought it to tend towards the ephemeral or towards permanence?

A. Those needs and designs that have a more universal quality will tend toward permanence.

Q. To whom does design address itself: to the greatest number (the masses)? to the specialists or the enlightened amateur? to a privileged social class?

A. To the need.

Q. Can public action aid the advancement of design?

A. The proper public action can advance most anything.

Q. After having answered all these questions, do you feel you have been able to practice the profession of "design" under satisfactory conditions, or even optimum conditions?

A. Yes.

Q. Have you been forced to accept compromises?

A. I have never been forced to accept compromises but I have willingly accepted constraints.

Q. What do you feel is the primary condition for the practice of design and its propagation?

A. Recognition of need.

Q. What is the future of design?

(No answer)

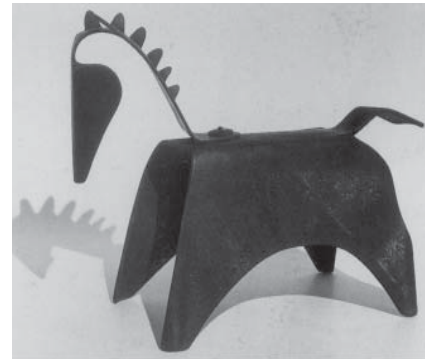
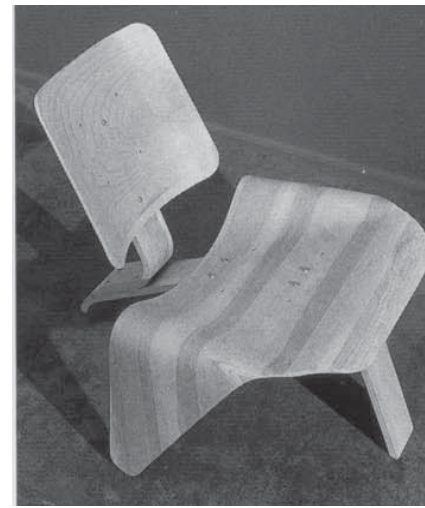

## ray & charles eames

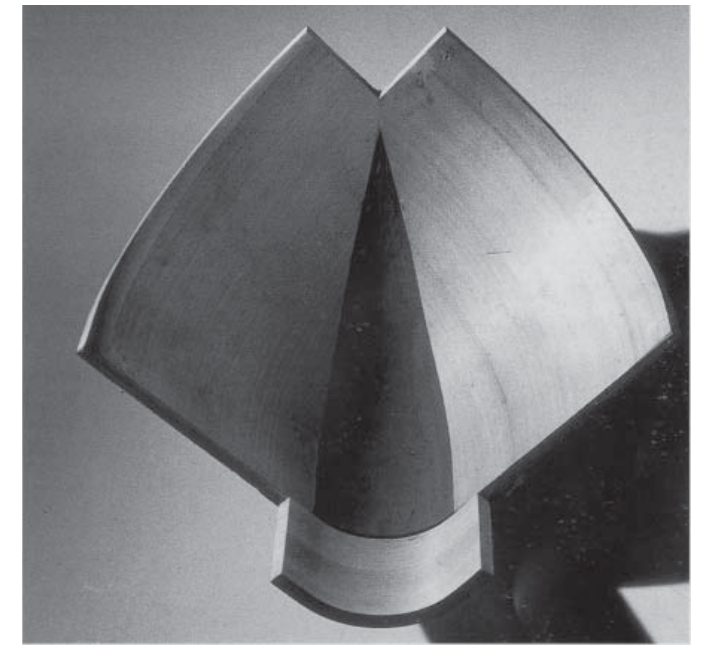

A concave form made by joining four separate pieces of molded plywood

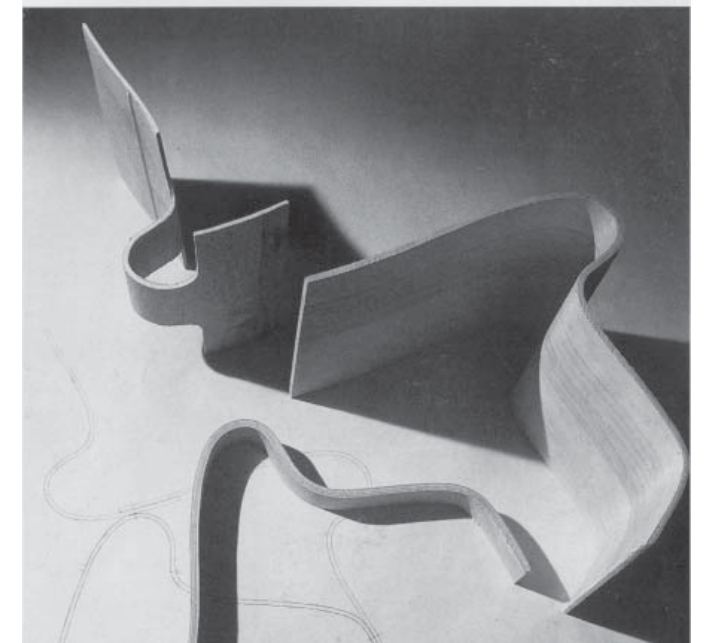

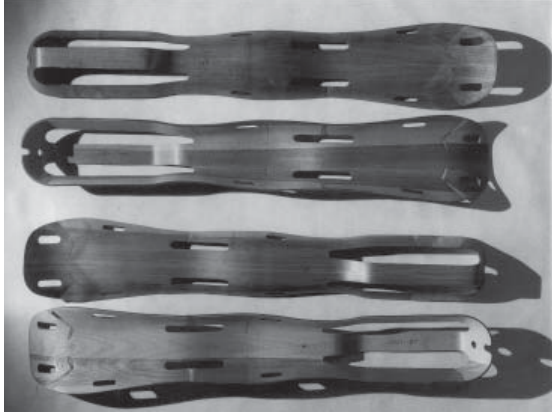

case study 05: process

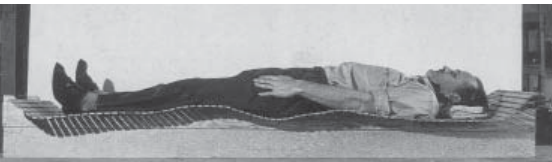

A demonstration of the flexible blanket of wooden dowels used to define the body shape

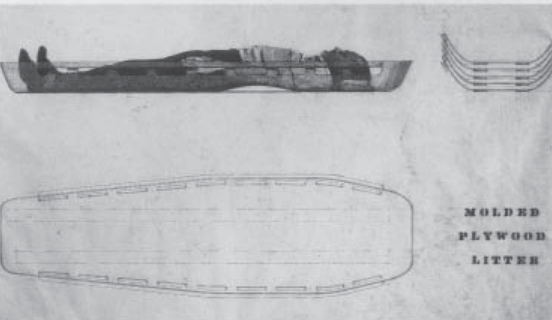

Final litter specifications



A demonstration of the ease with which the litter could be transported by using the perimeter gripping holes



ray & charles eames

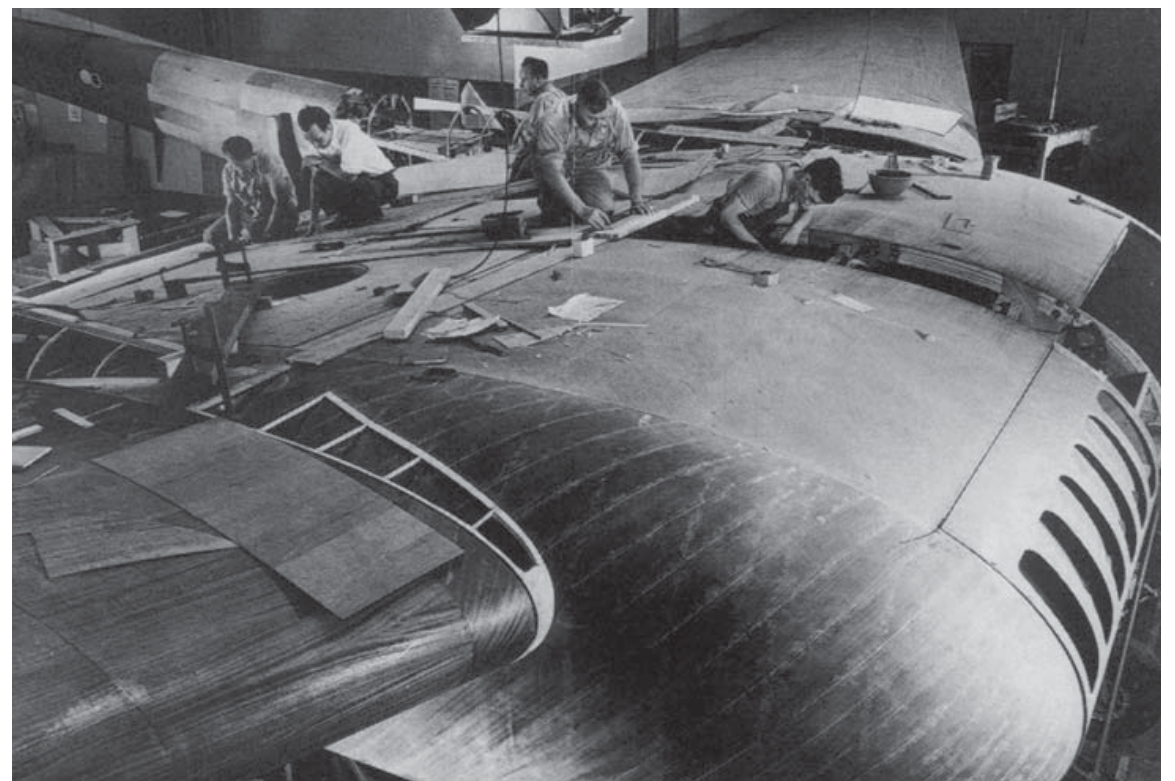
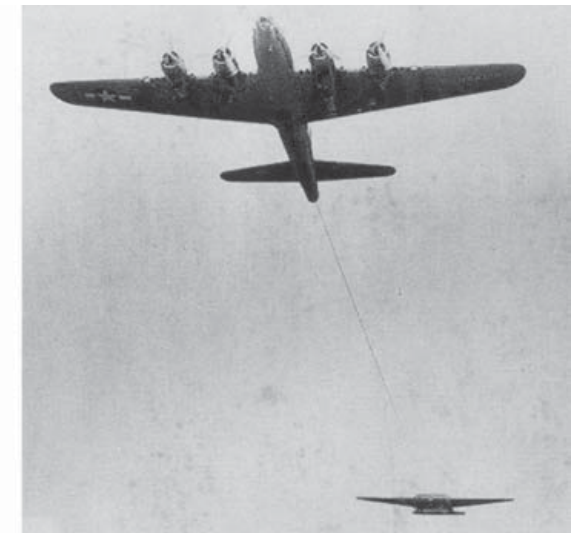
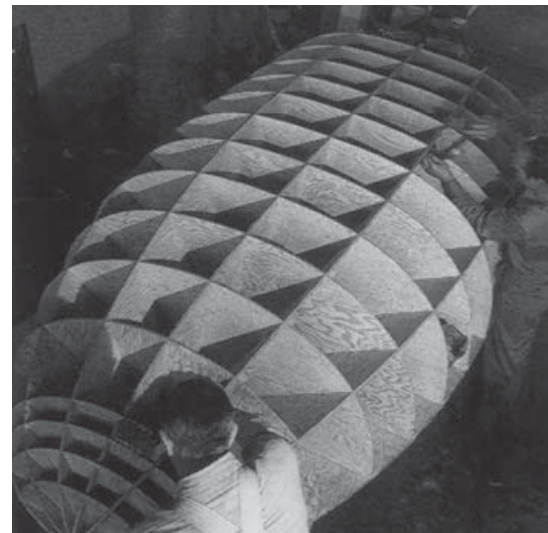

Eames' Lives	Dates	World Events
	1800s	Industrial Revolution
Charles Eames Born	1907	Automobile & Airplane Introduced
Ray Kaiser Born	1912	
	1914-1918	WWI
	1919-1933	Prohibition; Jazz Music
Charles Studying	1925-1928	
Charles Married to Catherine Woermann	1929	
Travel to Europe on Honeymoon & saw work of Corbusier; Mies; Walter Gropius		
Charles Starts Business; Only Child Born	1930	
	1929-1940	Depression
Ray Studying with Hans Hoffman (painter)	1933	
Charles Goes To Cranbrook Academy meets Ray Kaiser and Saarinen	1935-40	
Charles Teaches at Cranbrook Interest in mass-production Ray to Cranbrook	1940s	Big Band Era (Frank Sinatra, Bing Crosby)

## case study 05: process

Charles divorces & marries Ray	1941	
Move to California		
Ray does Graphic design for Arts & Arch magazine		
Commission from US Navy for molded plywood splints and litters during WWII		
Herman Miller - designs for		
Charles Starts New Design Firm (architecture)	1941-1945	WWII; Rationing of Steel
Ray - graphic design for Herman Miller/Eames		
Case Study House with Entenza	1949	
Building with standardized building elements in response to need after WWII		
	1947-1991	Cold War
	1950s	Television; Rock & Roll (Elvis)
Designed Game "The Toy" - Charles' son would be 21 yrs old; grandson maybe?	1950-1953	Korean War
Eameses foremost designers of this era	1950s-1960s	GI mortgages; space not as much of an issue
Focusing on Film and Toys	1960-1973	Vietnam War
Films:		
	1960s	Civil Rights Movement; Womens' Liberation
		Expansion of Drug Culture
	1963	JFK Assassinated
	1968	Robert F. Kennedy & Martin Luther King Assassinated
	1969	US men on moon
	1970s	Proliferation of flower children; reaction to Vietnam
		Recession - oil embargoes and high interest rates; making most of space again
	1974	Watergate Scandal; Nixon Resignation
Commissions from IBM/Corporations	1970s-1980s	Computer Explosion
Charles Eames Dies	1978	

Ray Eames Dies	1988	
	1991	Collapse of the Soviet Union
		Gulf War
	2000	Y2K Problem; Religion - End of Time
	2001	Terrorist Attack; 9-11
		Bioterrorism - Anthrax; 9-18 and 10-9 sent through U.S. mail
	2002	William McDonough, <i>Cradle to Cradle</i>
	2003	Iraq War - ongoing
	2004	Natural Disaster - Tsunami Indonesia
		Health; <i>Supersize Me</i>
	2005	Hurricane Katrina
	2006	Al Gore, <i>An Inconvenient Truth</i>
	2008	Recession Election Year

## timeline of ray & charles eames' life

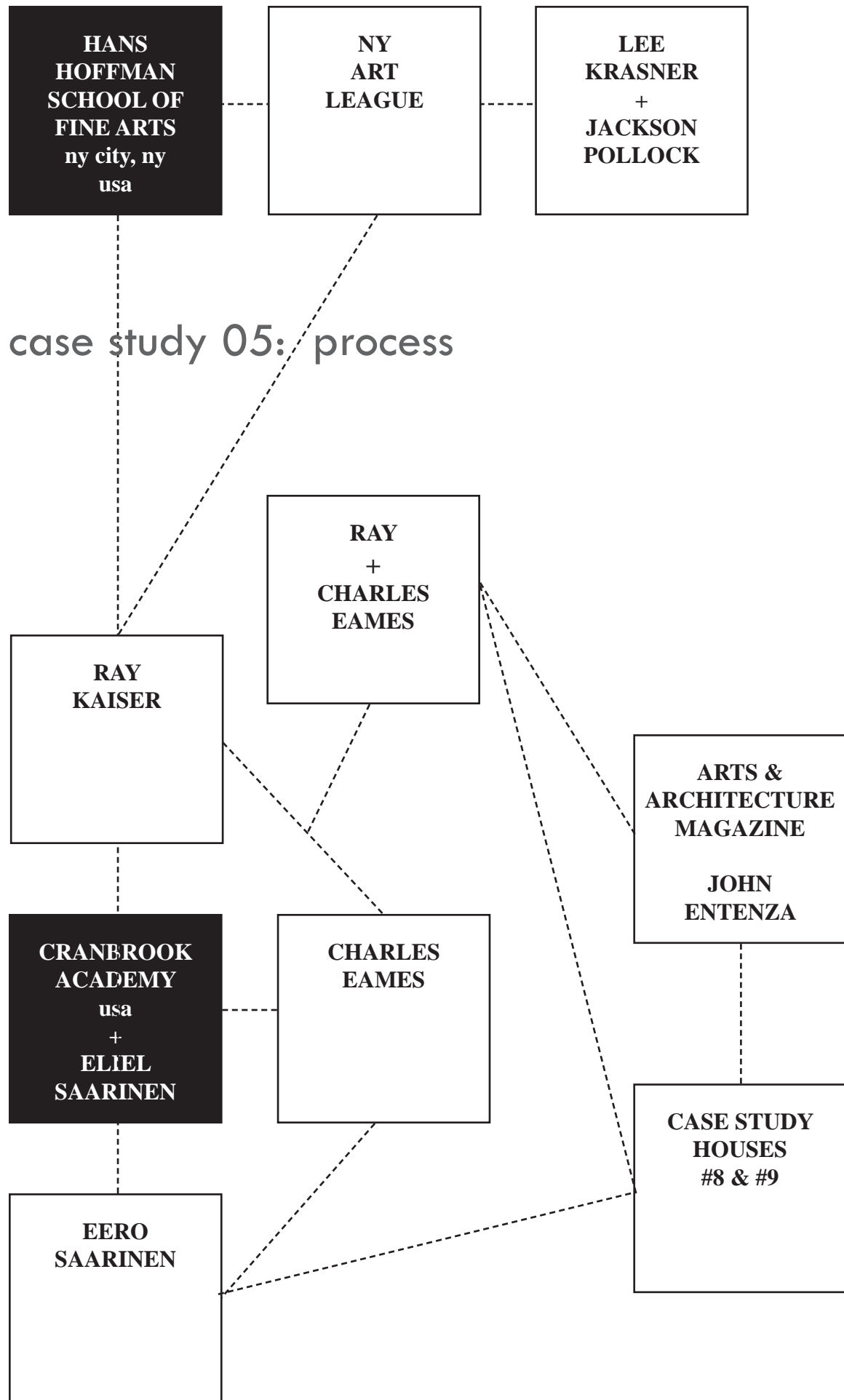

case study 05: process

## contemporaries of ray & charles eames

Contemporaries	Dates	Field of Work
Louis Sullivan	1856 - 1924	Schlesinger-Mayer store, Chicago 1899
Wassily Kandinsky	1866 - 1944	Artist
Frank Lloyd Wright	1869 - 1959	Robie House, Chicago 1908
Piet Mondrian	1872 - 1944	Artist
Pablo Picasso	1881 - 1973	Artist
Walter Gropius	1883 - 1969	Bauhaus, Dessau, Germany 1925
Sinclair Lewis	1885 - 1951	American Writer
Le Corbusier	1887 - 1965	Villa Savoye, Poissy, France
Buckminster Fuller	1895 - 1983	Designer, Architect, Author, Inventor
Alexander Calder	1898 - 1976	Artist, Sculptor
Henry Moore	1898 - 1986	Artist, Sculptor
Ernest Hemingway	1899 - 1961	American Writer
Alberto Giacometti	1901 - 1966	Artist, Sculptor
W.H. Auden	1907 - 1973	British Writer
William Faulkner	1897 - 1962	American Writer
John Steinbeck	1902 - 1968	American Writer
Marcel Breuer	1902 - 1981	Architect, Furniture Designer
Edward Durell Stone	1902 - 1978	MOMA
Phillip Johnson	1906 - 2005	MOMA
Charles Eames	1907 - 1978	Industrial Design/Architecture, Fine Art
Francis Bacon	1909 - 1992	Artist (Painting, 1946)
Eero Saarinen	1910 - 1961	Architect, product designer
Ray Eames	1912 - 1988	Industrial Design/Architecture, Fine Art
Jackson Pollock	1912 - 1956	Artist
Florence Knoll	1917 -	Architect, Interior Designer
Ralph Caplan	1925 -	Writer, design consultant, wrote for and about Herman Miller Inc.

Artists, Writers, Musicians 700 Years of their Lives and Works. 1. New York & London: The Diagram Group

“Like partners in any other architecture firm, married couples design together, make business decisions together, meet with developers as a team and travel to building sites in tandem. Interviews with some couples suggest that it can be tricky. There are the perceptions of the outside world to contend with: the idea that men are muscular masters of tectonics, and women, glorified interior decorators. There are the strains of heavy travel and long days while working and living together, and the potential for design arguments to escalate into marital power struggles.

But on the whole, married architects suggested, the married relationship is a plus for the architecture, allowing for an unsparing candor that takes the work to a higher level.

““We rely on critiquing each other to death, a kind of Ping-Pong,” said Ms. Andraos, who founded Work Architecture with Mr. Wood in 2002. “When we agree, we know that it’s good. ““ (Pogrebin)



Tod Williams & Billie Tsien

## case study 05: process

- ARCHITECTURE
- RAY & CHARLES EAMES (20th c.)**  
ARCHITECT, DESIGNER, PHOTOGRAPHER, FILM-MAKER, INVENTOR / FINE ARTIST,
  - HANS & FLORENCE KNOLL (20TH c.)**  
FURNITURE DESIGNER / ARCHITECT
  - TOD WILLIAMS & BILLIE TSIEN (contemporary)**  
ARCHITECTS
  - CHARLES & MARGARET MACKINTOSH (late 19th c., early 20th c.)**  
ARCHITECT, DESIGNER, ARTIST / ARTIST
  - BEN VAN BERKEL & CAROLINE BOS (contemporary)**  
ARCHITECTS (MERCEDES BENZ MUSEUM)
  - RICARDO SCOFIDIO & ELIZABETH DILLER**  
ARCHITECTS
  - DAN WOOD & AMALE ANDRAOS**  
ARCHITECTS
  - ERIC HOWELER & J. MEEJIN YOON**  
ARCHITECTS
  - ERIC BUNGE & MIMI HOANG (contemporary)**  
ARCHITECTS
  - MARIO GANDELSONAS & DIANA AGREST**  
ARCHITECTS
  - JONATHAN KNOWLES & LAURA BRIGGS**  
ARCHITECTS
  - ROBERT & DENISE SCOTT BROWN**  
ARCHITECTS
- ART
- CHRISTO & JEAN CLAUDE (late 20th c.)**  
FINE ARTISTS
  - JACKSON POLLOCK & LEE KRASNER (early 20th c.)**  
FINE ARTISTS
  - DIEGO RIVERA & FRIDA KAHLO (early 20th c.)**  
FINE ARTISTS

## creative couples in collaboration

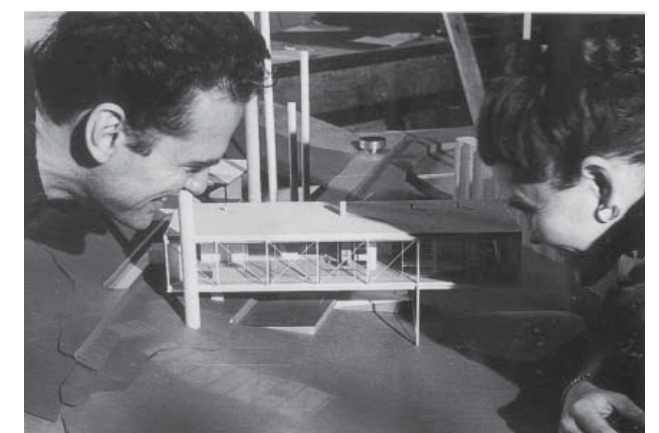
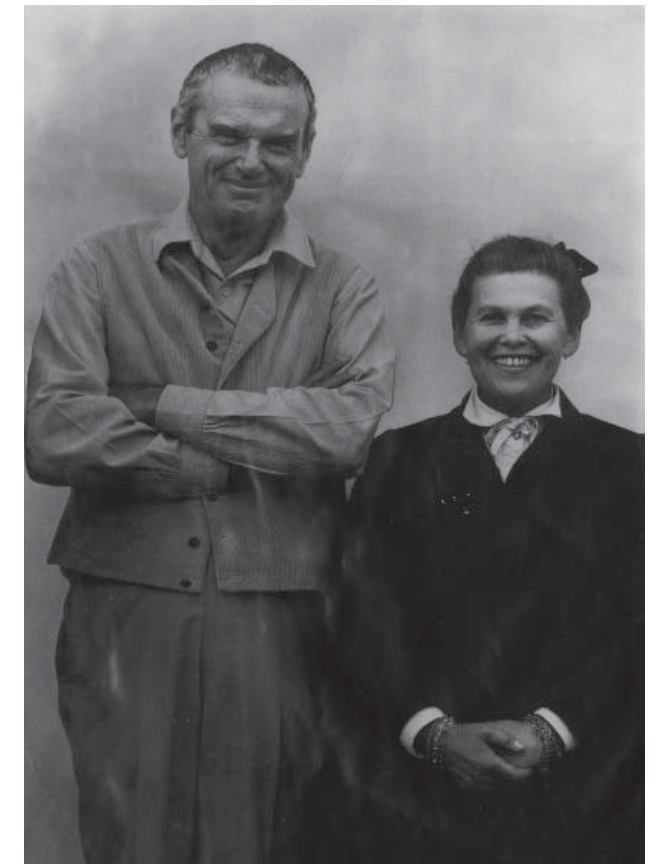
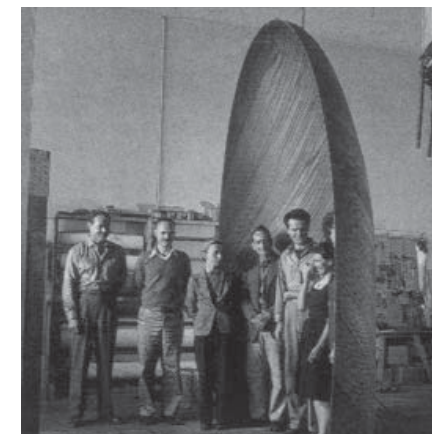

ray and charles eames at play



FILM

**WILLIAM MORRIS & JANE BURDEN (late 19th c.)**  
ARTIST, WRITER, ACTIVIST / ARTIST

**FREDERICO FELLINI & GIULIETTA MASINA (20th c.)**  
FILM-MAKER / ACTRESS

**FRANCIS FORD COPPOLA & ELEANOR NEIL (contemporary)**  
DIRECTOR/PRODUCER, SCREENWRITER / ASST. ART DIRECTOR

**BAZ LUHRMANN & CATHERINE MARTIN (contemporary)**  
DIRECTOR/PRODUCER, SCREENWRITER / PRODUCTION DESIGNER

**DESI ARNAZ & LUCILLE BALL (20th c.)**  
ACTOR, MUSICIAN, PRODUCER / ACTRESS, COMEDIAN

**ROBERTO ROSSELLINI & INGRID BERGMAN (mid 20th c.)**  
DIRECTOR / ACTRESS

**JUDY GARLAND & VINCENTE MINNELLI (late 20th c.)**  
SINGER, ACTRESS / DIRECTOR

**MAURICE & GEORGIANA DREW BARRYMORE (late 19th c.)**  
BROADWAY ACTOR / THEATER ACTRESS

case study 05: process

**JOHN & ETHEL BARRYMORE (early 20th c.)**  
ACTOR / STAGE ACTRESS

**KURT RUSSELL & GOLDIE HAWN (contemporary)**  
ACTOR / ACTRESS

**OSSIE DAVIS & RUBY DEE (20TH c.)**  
ACTOR, DIRECTOR, POET / ACTRESS (CIVIL RIGHTS ACTIVISTS)

**PAUL NEWMAN & JOANNE WOODWARD (late 20th c.)**  
ACTOR, DIRECTOR / ACTRESS

**JOEL COEN & FRANCES MCDORMAND (contemporary)**  
DIRECTOR / ACTRESS

MUSIC

**DAVID FINKEL & WU HAN (contemporary)**  
CELLIST / PIANIST

**ALAN & MARILYN BERGMAN (mid-late 20th c.)**  
SONGWRITERS

**STEVE LAWRENCE & EYDIE GORME (mid 20th c.)**  
SINGERS (POP DUETS)

LITERATURE

**ROBERT & ELIZABETH BARRETT BROWNING (19th c)**  
POETS

**PERCY & MARY SHELLEY (19th c.)**  
POET, MENTOR / AUTHOR (FRANKENSTEIN)

**NICHOLAS ROERICH & HELENA IVANOVNA (early 1900s)**  
RUSSIAN ARTIST, AUTHOR / AUTHOR

POLITICS

**JOHN & COKIE ROBERTS (contemporary)**  
NEWS COMMENTATORS

**FRANKLIN & ELEANOR ROOSEVELT (20th c.)**  
PRESIDENT & FIRST LADY

**BILL & HILLARY CLINTON (contemporary)**  
PRESIDENT & FIRST LADY/GOVERNOR

creative couples in collaboration

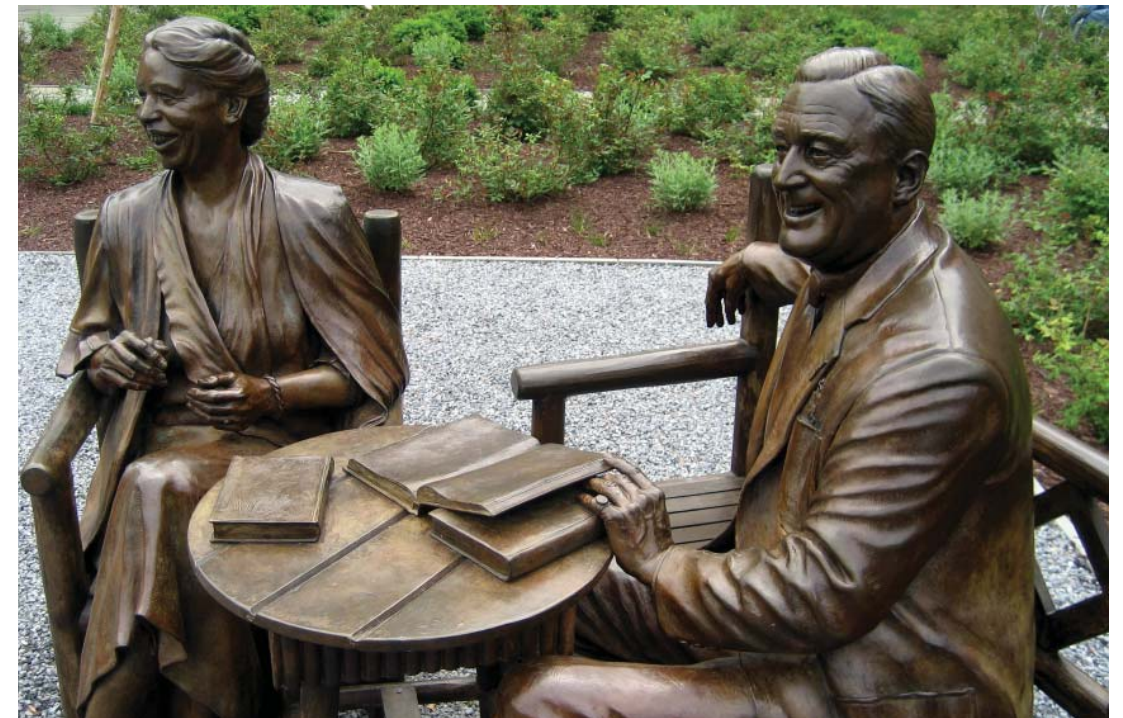

franklin delano and eleanor roosevelt statue



## case study 06: program

### Friends in Collaboration

Blu Dot is a furniture design and manufacturing, based in Minneapolis, Minnesota founded by three college friends: John Christakos, Maurice Blanks, and Charles Lazor.

“Our goal is to bring good design to as many people as possible. Which means creating products that are useful, affordable, and desirable. To make this happen, our design process is founded on collaboration. Not just among ourselves as we play show-and-tell with concepts, but a total collaboration between pencil and paper, material and machines, even packaging and assembly. We like to think that the form is almost inevitable, a by-product of the process.

Our job is simply to help it emerge as beautifully and efficiently as possible”

-Blu Dot Catalog No. 9, 2007-2008



## blu dot furniture

“With the inventive, can-do spirit that characterized the work of the Eameses, Blu Dot has resurrected the values of the Good Design movement and its popular potential.”

- Marissa Bartolucci, American Contemporary Furniture



blu dot furniture, images courtesy of blu dot

This project began with my ongoing tribulations with moving. From one location to the next home or room, we are constantly reminded of the weight of furniture. It is often heavy, poorly constructed, and cumbersome. Over the years, companies like IKEA have designed lightweight furniture priced for a young person on the move. Their storage systems, shown opposite, can be easily reconfigured allowing simple changes from bench to bookcase. This design has served me throughout the years but to keep the cost down for the target demographic, inexpensive materials are often used. The result is inevitably the dumpster, not the targeted end user. Moving companies are known for not insuring Ikea products. Citimove's website has the following disclaimer:

“...please note: we are not responsible for pressboard furniture (like Ikea, Staples, Target, Office Depot type furniture as it's weak and doesn't move well unless it's unassembled) but we'll take the utmost care in moving them.”  
 - Citimove, LLC

## case study 07: program

### IKEA Catalog

#### Product Specifications:

Traby Shelf Unit - (1) Width: 16 1/8", Depth: 15 3/8", Height: 16 1/8" \$39.99  
 Traby Shelf Unit - (1) Width: 16 1/8", Depth: 15 3/8", Height: 31 1/2" \$49.99  
 Traby Shelf Unit - (1) Width: 31 1/2", Depth: 15 3/8", Height: 16 1/8" \$49.99  
 Traby Shelf Unit - (1) Width: 31 1/2", Depth: 15 3/8", Height: 31 1/2" \$79.99

#### Product information:

Color variations in the veneer give your shelf combination a unique appearance.  
 Brushed surface; gives a genuine wooden feel.  
 Adjustable feet for stability on uneven floors.

#### Product description:

Board on frame: Particleboard, Fiberboard, Ash veneer, Clear acrylic lacquer, Ash veneer, Honeycomb structure recycled paper filling  
 Back: Ash veneer, Fiberboard, Clear acrylic lacquer

#### Installation:

This product requires assembly  
 This furniture must be secured to the wall with the enclosed anti-topple device.  
 Different wall materials require different types of fasteners. Use fasteners suitable for the walls in your home (not included).  
 Can be used with doors/drawer unit for concealed, dust-free storage.  
 May be completed with TRÅBY legs.

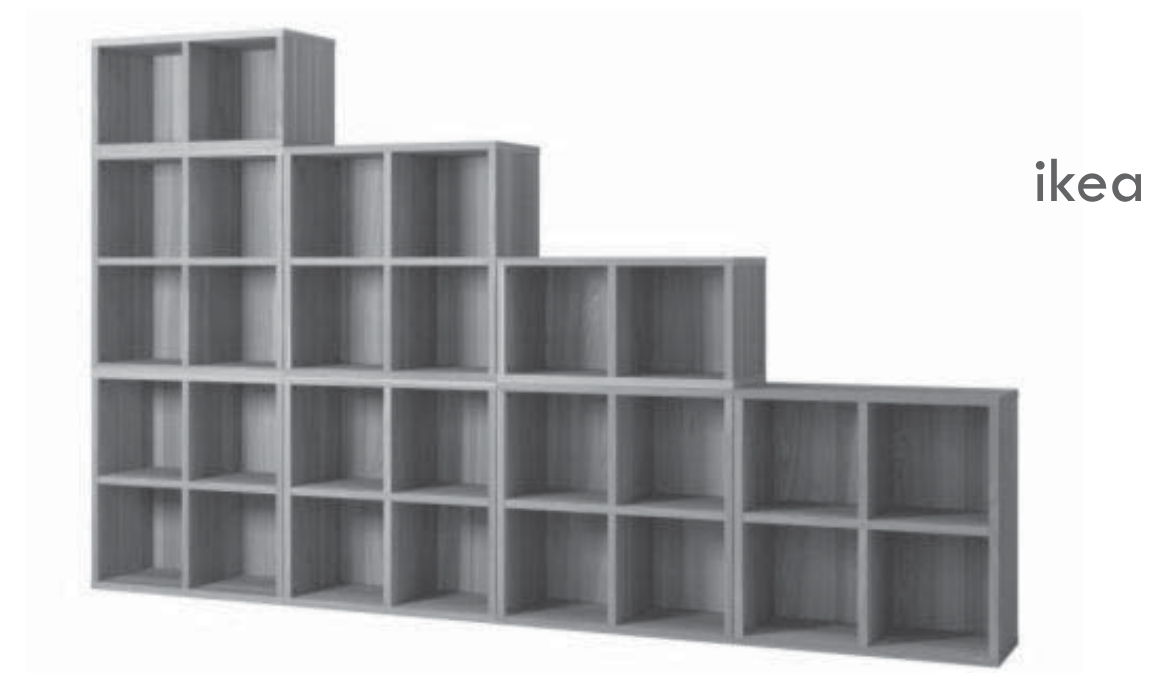
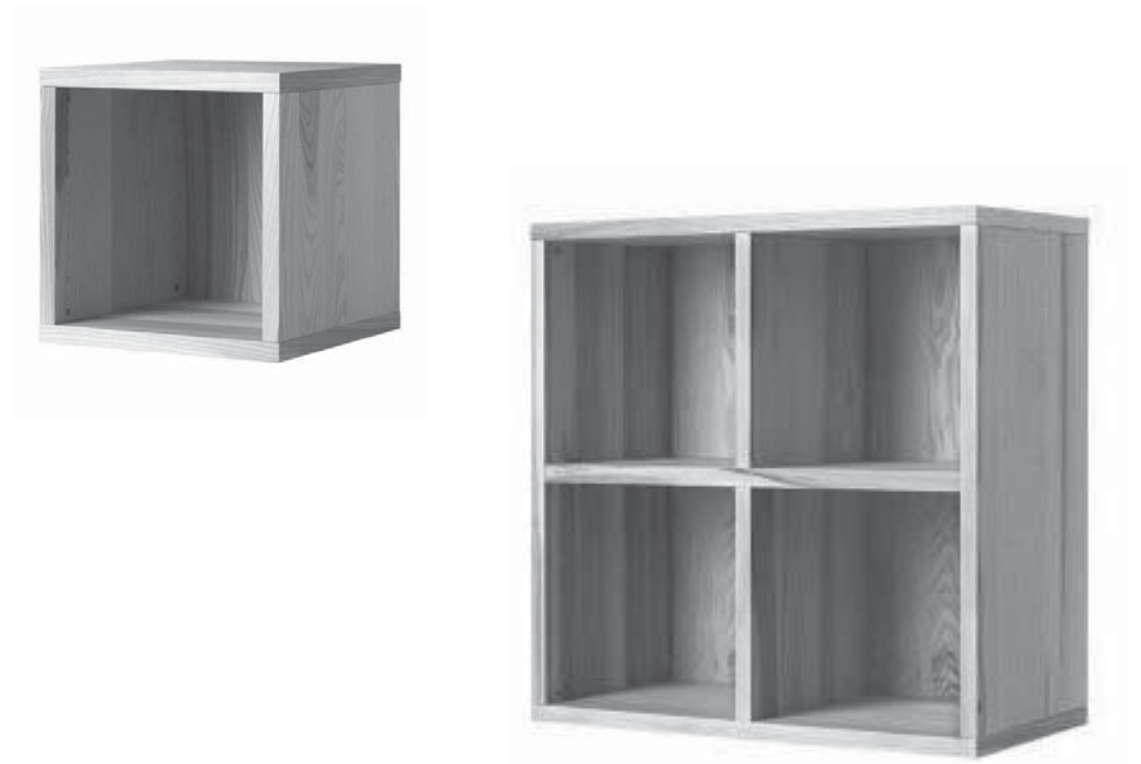

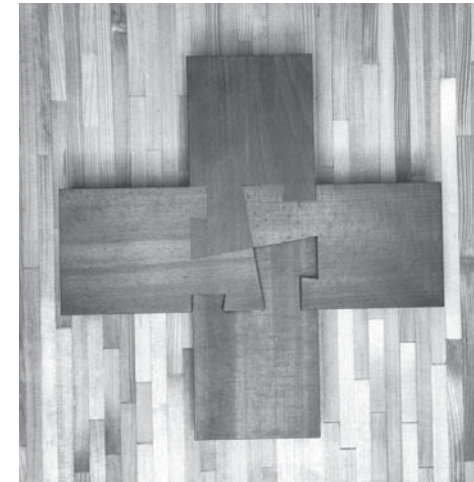
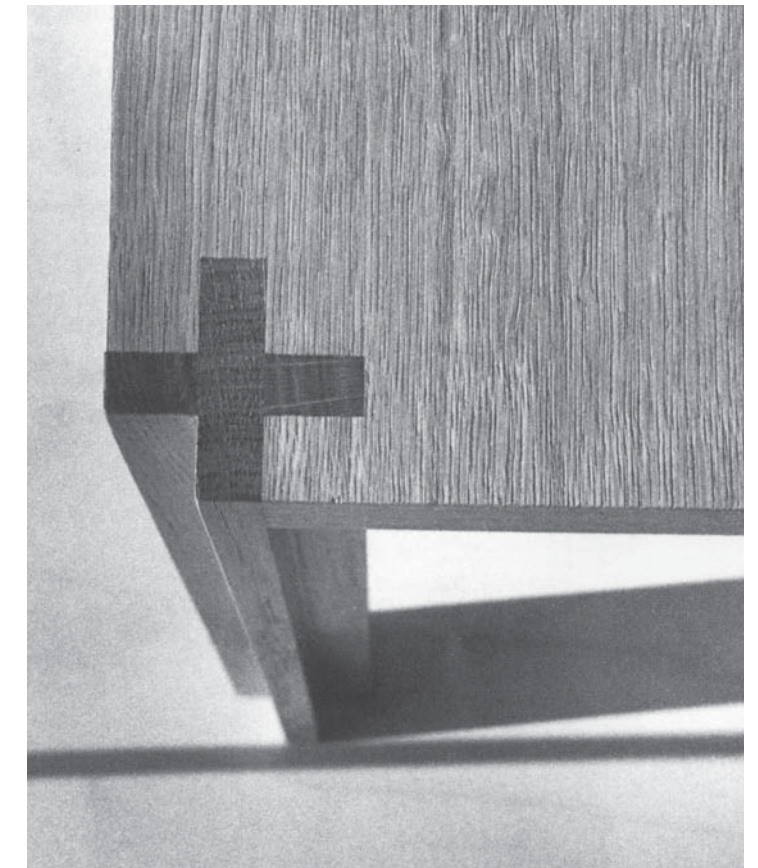
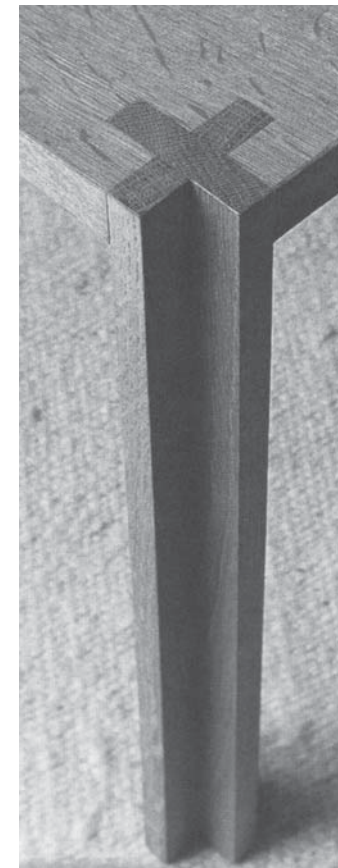
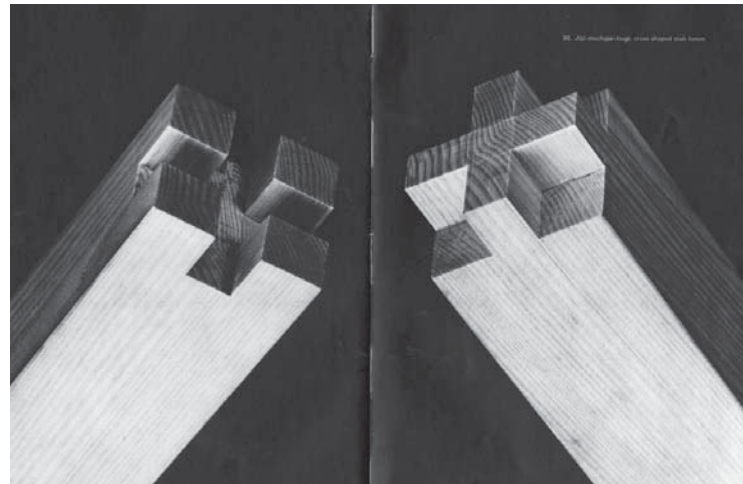
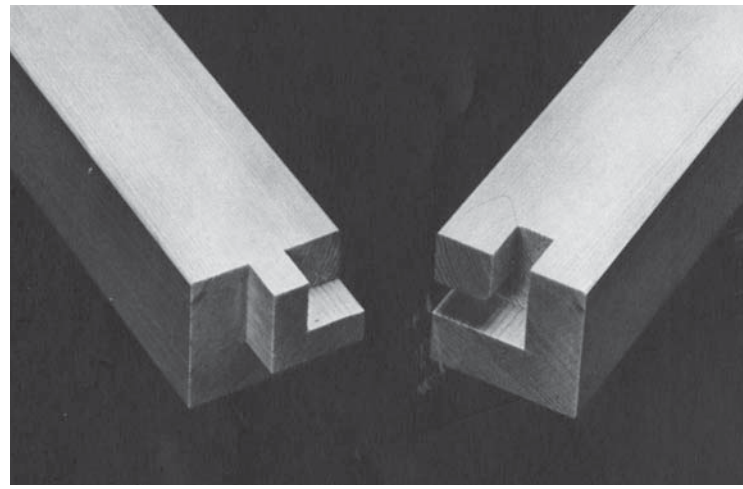

## case study 08: program

Japanese joinery is an art. Since 3000 B.C., the Japanese have been building with wooden framework. In historical times, Japan was heavily forested so when the Chinese and Europeans were building with stone and clay, they were experimenting with post and lintel construction. In order to continue their ancient traditions once their good timber had been felled, they made use of knotted and gnarled timber. (Seike)

The joinery images opposite are from a book titled "Joint Connections." This biography about Werner Blaser's work presents some of the same ideologies presented in this thesis. Blaser was concerned with joinery, creating a connection between furniture and architecture, and wood construction in particular. The leg cruciform section separates and joins at the same time. Gluing the eight surfaces stiffens the structure enough that bracing is unnecessary. (Blaser) It was a bitter sweet moment when I found this book in our school library, just after our mid-semester critique. I was unsure of my process and how to move forward. When I saw the work Werner Blaser had done I was rejuvenated. The program and process he followed were similar to mine, down to the model size components he created. It gave me back confidence in my progress. It was saddening to know that something so similar had been done so beautifully but exciting at the same time.

The red dresser, opposite, is the Plus Unit Drawer System by Werner Aisslinger for Magis. The configuration possibilities are limitless and perfect for creating an eye-catching room divider, coffee table, storage system, entertainment center and on and on. This product is available with or without wheels and comes in glossy ABS drawer unit, polished aluminium runners, and caps in polished aluminium or painted aluminium in the same color as the drawer. Single, double, and triple compositions available. Designs like these utilize construction techniques that have transcended centuries and millennia.

## joint connections



werner blaser process work 2



magis plus unit 11

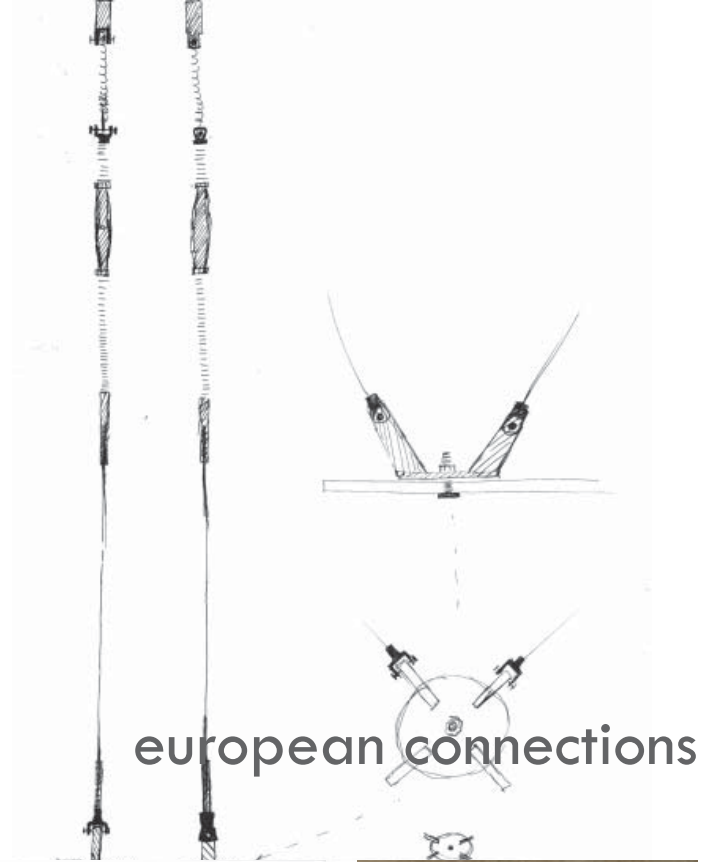
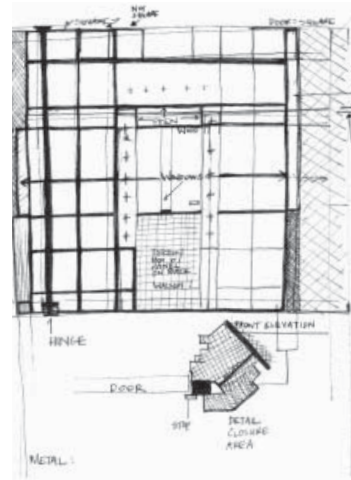

case study 09: program

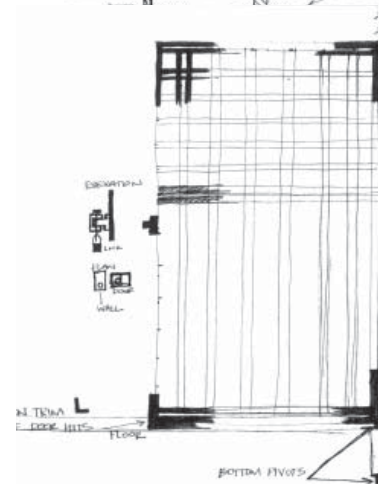
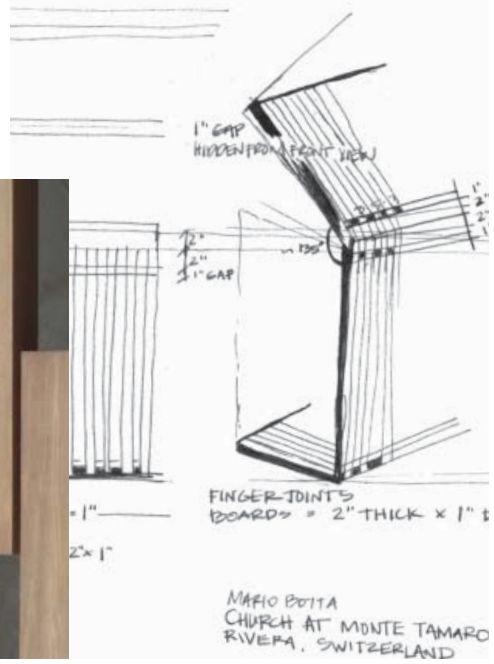

## case study 10: program

The founder of Legos, Ole Kirk Christiansen (1891-1958), was a Danish master carpenter and toymaker. His early toys were made of wood but in the forties he began experimenting in plastics. The first interlocking plastic bricks were produced in 1947. A conversation with a client led to the experimentation and development of a universal toy system. The current-day lego brick was invented and by the mid-60s was being sold around the world. The product has adapted over the years but the beauty of the system is that the 1960s Legos are still compatible with our contemporary versions. A concept rather foreign to a technology obsessed society, a new ipod out every week and computers out of date in two years. (Wikipedia)

The product is made by molding a resilient plastic called ABS, acrylonitrile butadiene styrene. The Lego Group is now producing themed play sets: robots, pirates, dinosaurs, wild west, trains that supplement the original design. "Clikits" were developed to appeal to young girls, with its arts and crafts decorative elements.

Other developments of the product include more technical components: motors, gears, lights, sensors, and cameras. The Lego NXT can be programmed with a PC or Mac to perform more complicated tasks. Mindstorms NXT was released in 2006, offering sensors

leg godt = play well

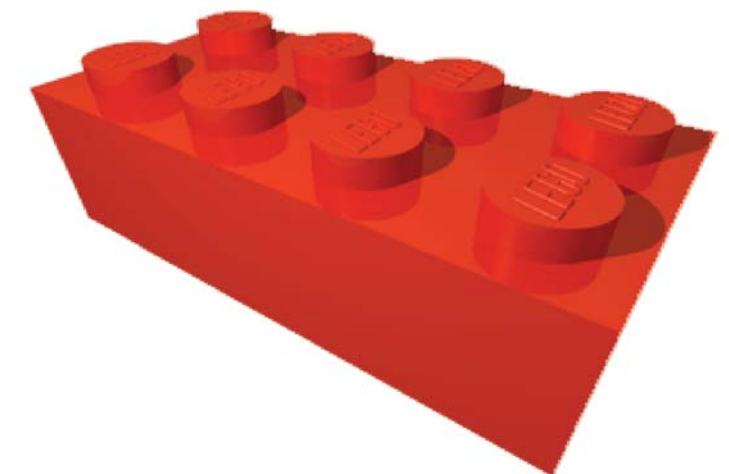

including touch, sound, light, and ultrasonic sensor technology. The Lego group has also branched into video games appealing to a wide range of age groups.

Since around 2000, the Lego Group has been promoting “Lego Serious Play,” a form of business consultancy fostering creative thinking, in which team members build metaphors of their organizational identities and experiences using Lego bricks. Lego Serious Play has been developed into a successful consulting method, used by a number of companies in a wide range of markets, including Daimler Chrysler, Roche Pharmaceutical, SABMiller, Tupperware, Nokia and Orange.

The Lego Group’s explains the validity of their services with defining principles:

**Play** - play is defined as a limited, structured, and voluntary activity that involves the imaginary. That is, it is an activity limited in time and space, structured by rules, conventions or agreements among the players, not coerced by authority figures, and drawing on elements of fantasy and creative imagination

**Constructionism** - based on the ideas of Seymour Papert, which built in turn on the Constructivist theories of Papert’s colleague Jean Piaget. Papert argued that learning happens especially when people are engaged in constructing a product, something external to themselves such as a sand castle, a machine, a computer program or a book.

## case study 10: program

**Imagination** - Throughout history, the term “imagination” has been given many different cultural and linguistic connotations. While all share the basic idea that humans have a unique ability to “form images” or to “imagine” something, the variety of uses of the term “imagination” implies not one, but at least three meanings: to describe something, to create something, to challenge something. (wikipedia)



leg godt = play well

### LEGO SERIOUS PLAY

A process developed to bring the creativity, the exuberance, and the inspiration of play to the serious concerns of adults in the business world.

<http://www.seriousplay.com/>

The images opposite are a system of components I designed while studying woodworking at VCU. I wanted to build something large--a chaise lounge--but had no where to store it once it was made. So, I decided a more important project would be to figure out how to make something large out of something small. These images show the components in their most compact position. When extended, the "Allthread" and nut fasteners separate the square tubes. The unit can then be turned on its side and become a shelving unit or structure for a table.

The components were stored away for some time but slowly became useful. The image below is a couch built with MOD1 as the legs and arm. They were also used as shelving units in my studio during my two years in the Interior Environments program. Pieces were even loaned to my classmates. The success of this idea made me want to address it again and make it better.

process

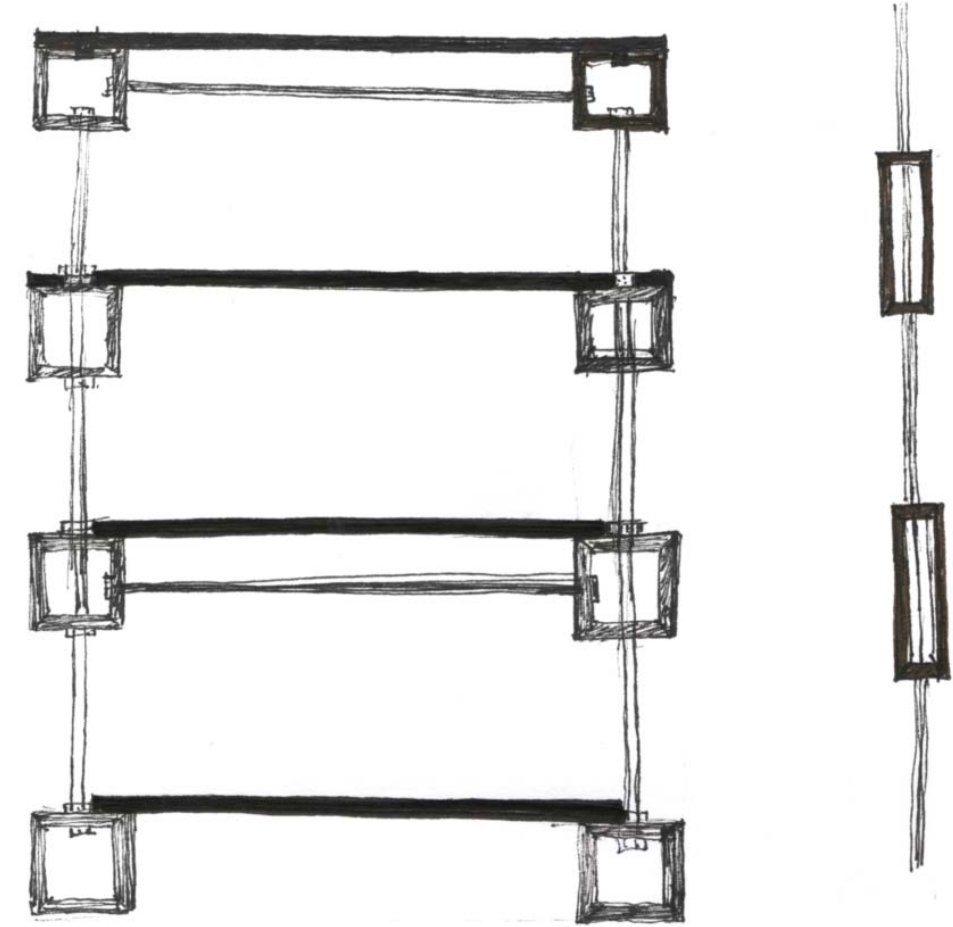
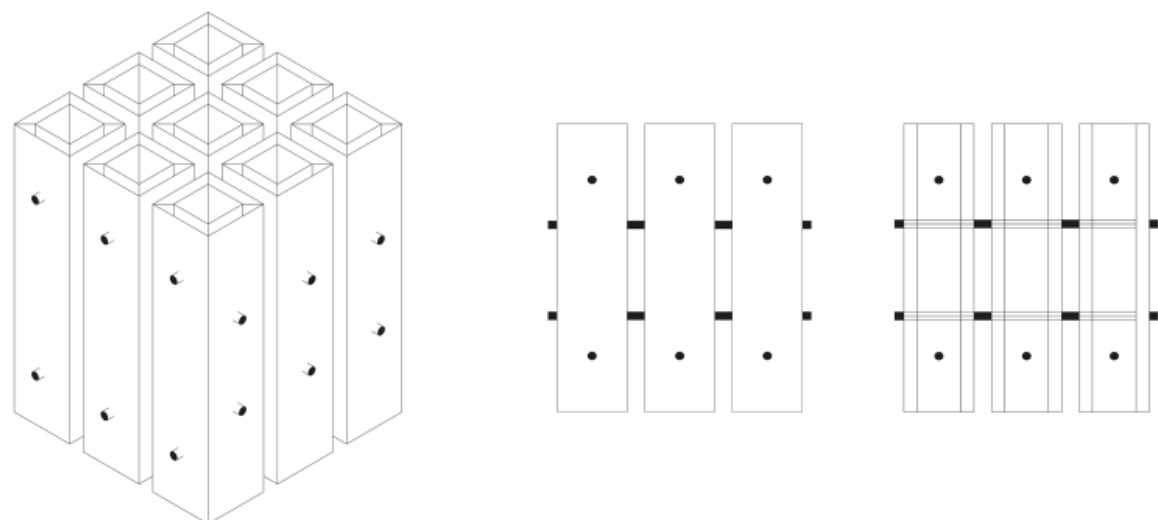
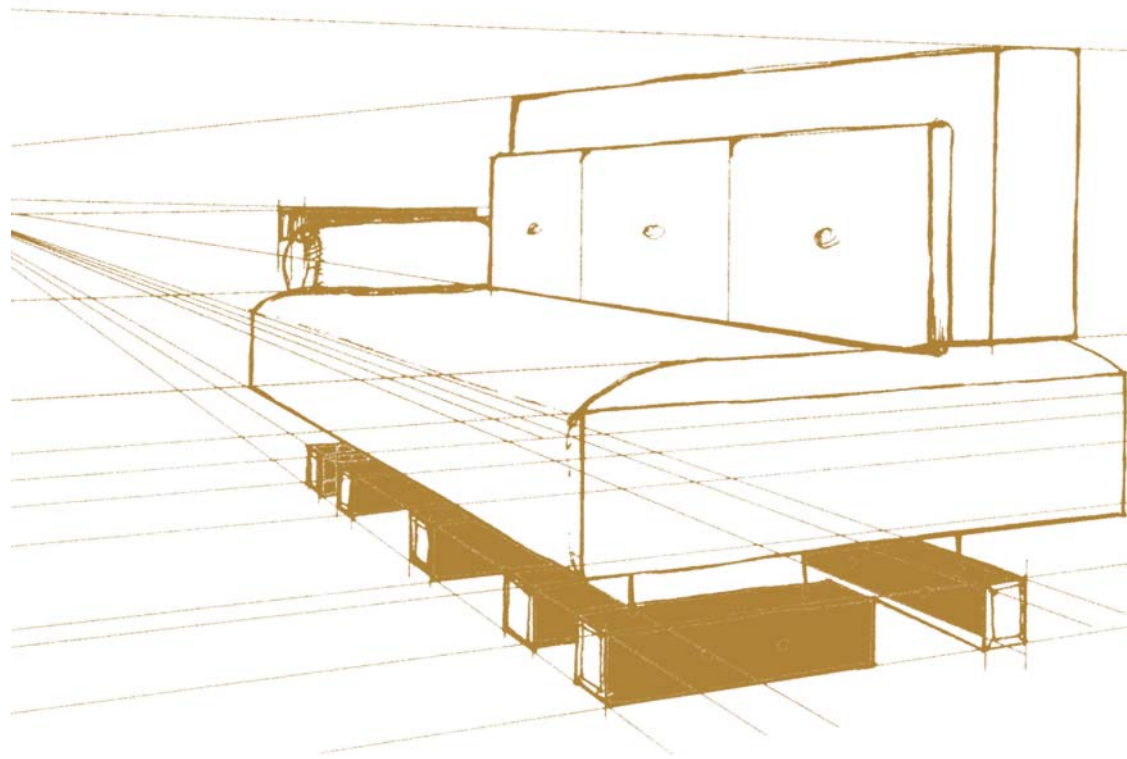

mod 1

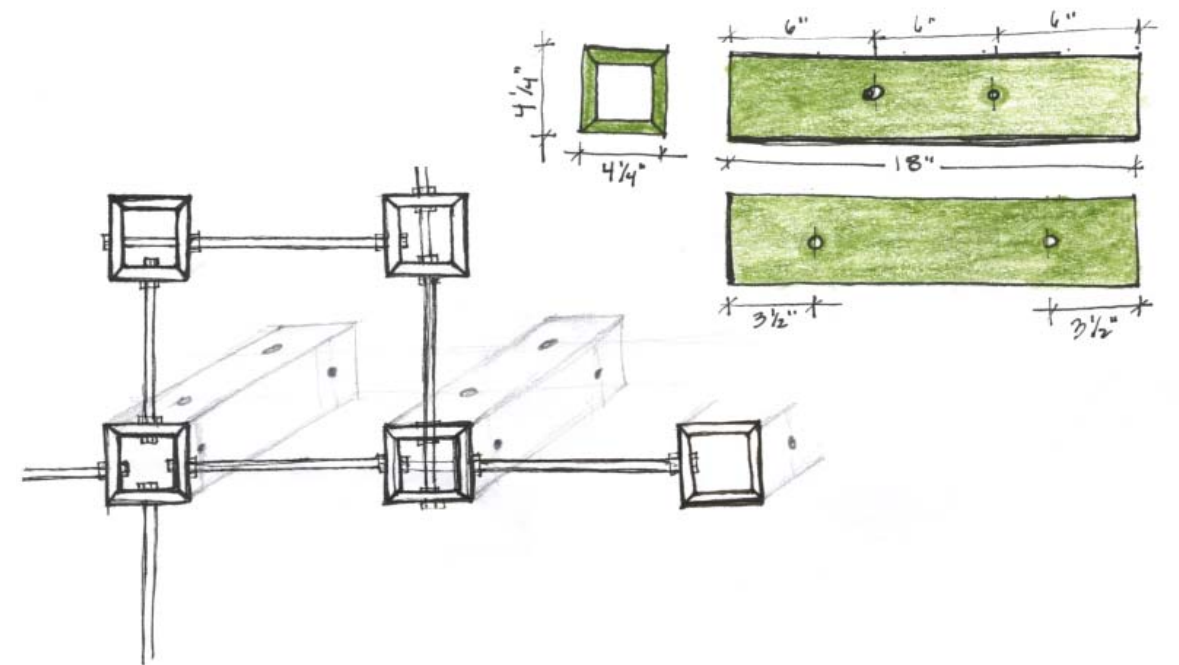



MOD 2 was the response to an assignment my first semester in the MFA design program. We were asked by our professor Camden Whitehead to create a space using “a system of construction.” My project was an interlocking system that could extend on the x, y, and z axes. “How does it turn a corner?”

I visited with my family in January and took these pieces for prototype testing. I documented with photography the different variations my nieces and siblings discovered. What I found interesting from this experiment was how one component could be used differently by so many different people. Many of the combinations were nonsense but this was exactly the type of exploration I wanted to encourage. I received comments about parts needed, what it could do and couldn't. I left with complete redesigns from my older brothers, of course they had all the answers.

I talked to my 14 year old niece about the project that night. I said “If you could make anything for your bedroom, what would it be?” She shrugged her shoulders, she couldn't think of a thing. The next morning I had a note waiting for me “just in case I couldn't tell you this is a bed case thing you know those um metal things that go around the bed a canope type thing. :) Luv ya hope it makes you lots of money :) Margaret.” That day I had a design charrette with my parents and brother Max. The input from others helped me understand what it needed to be so I could start on a new path. I started modeling that weekend and returned to the studio with parts of MOD3.

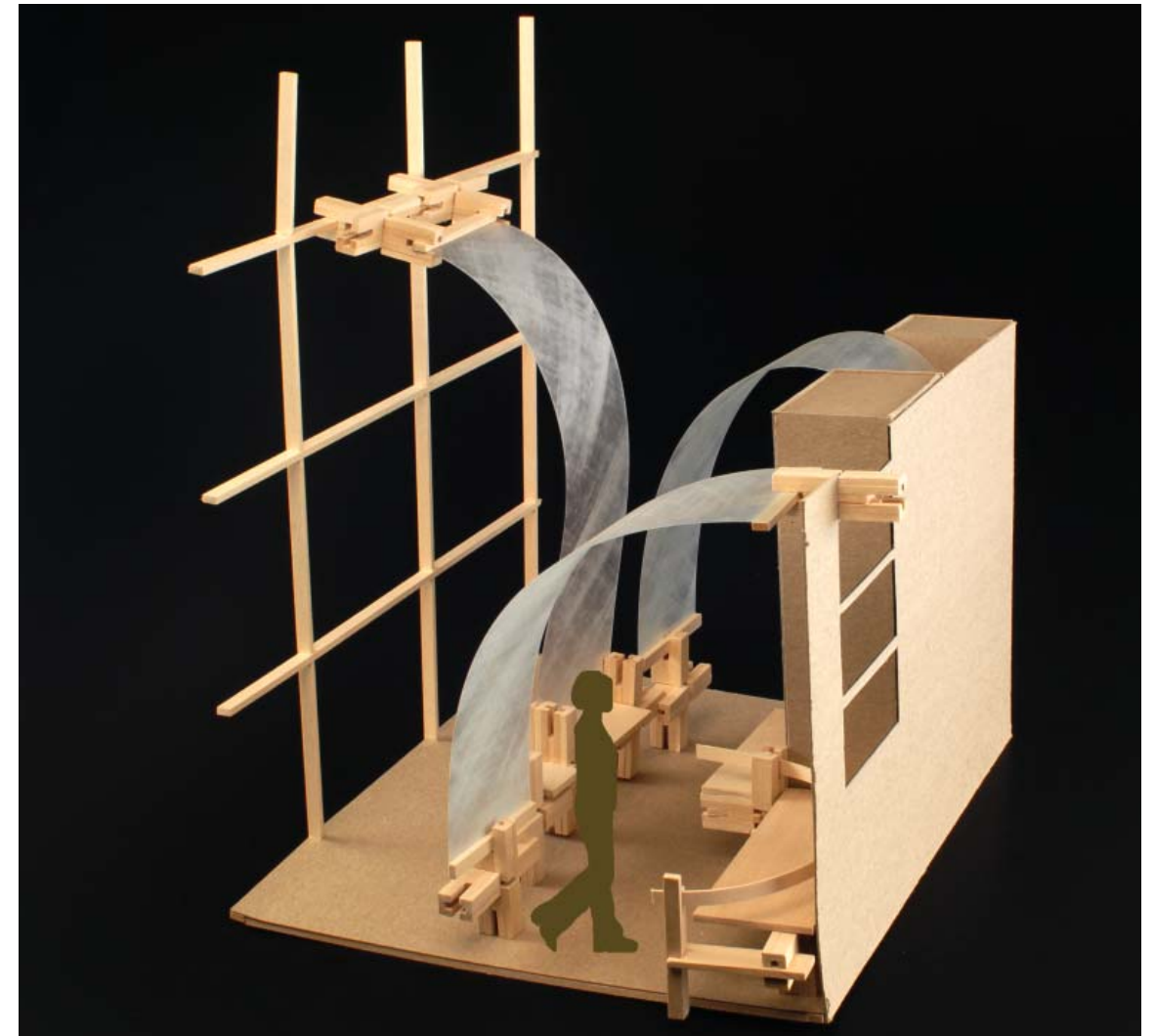
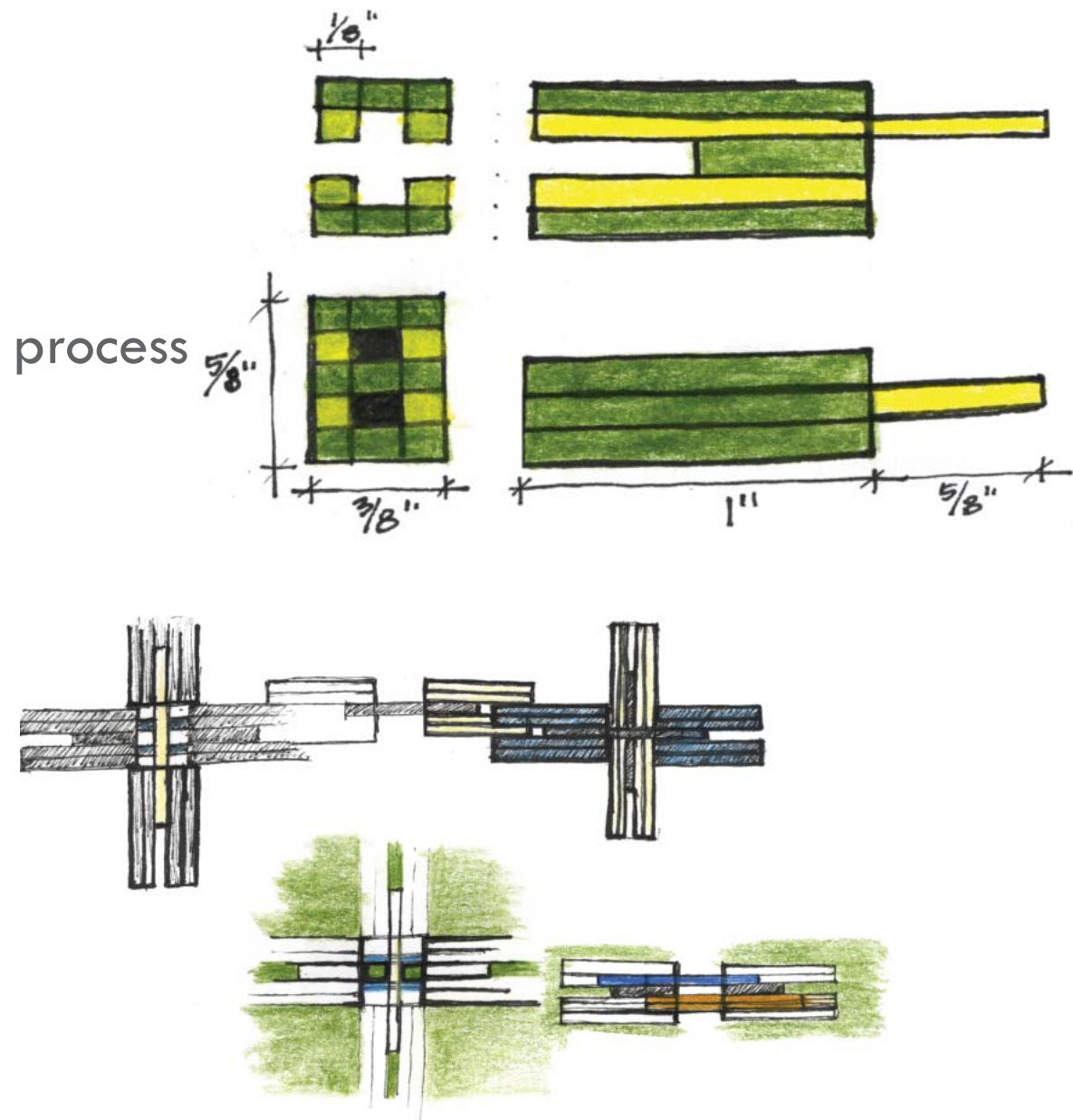

mod 2

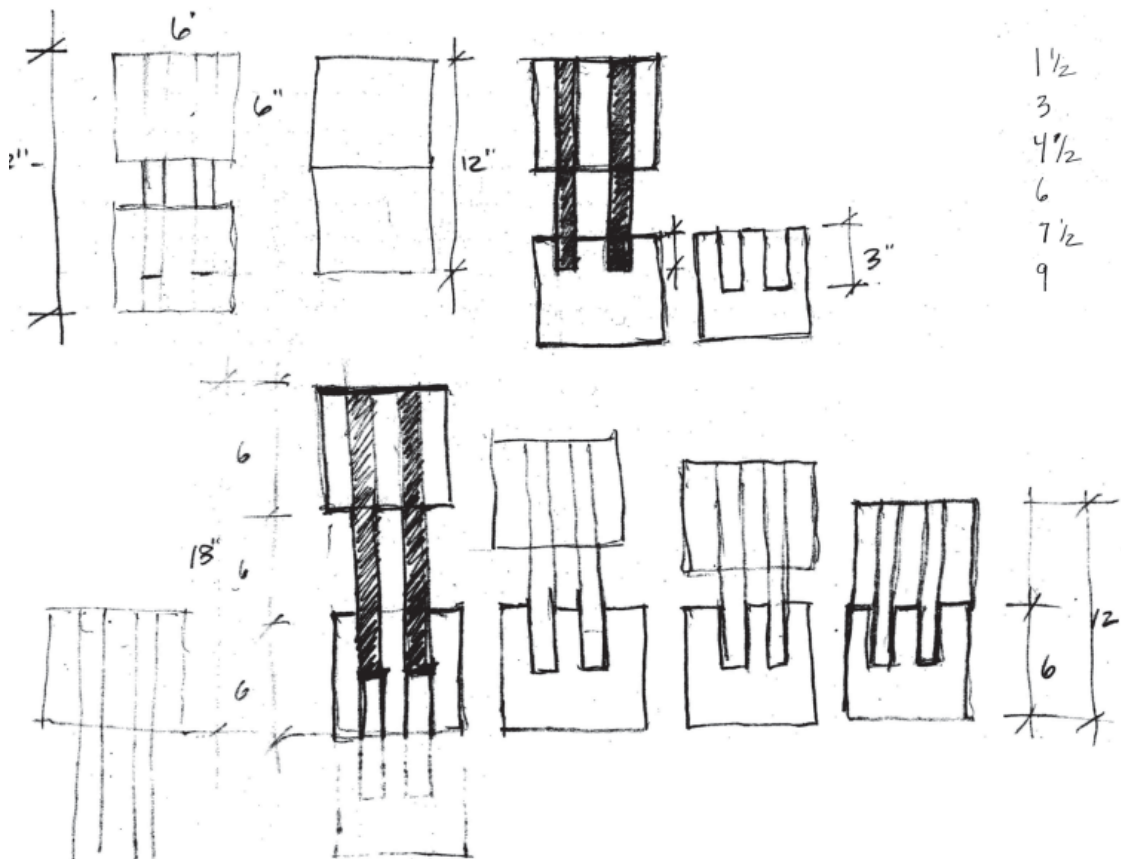
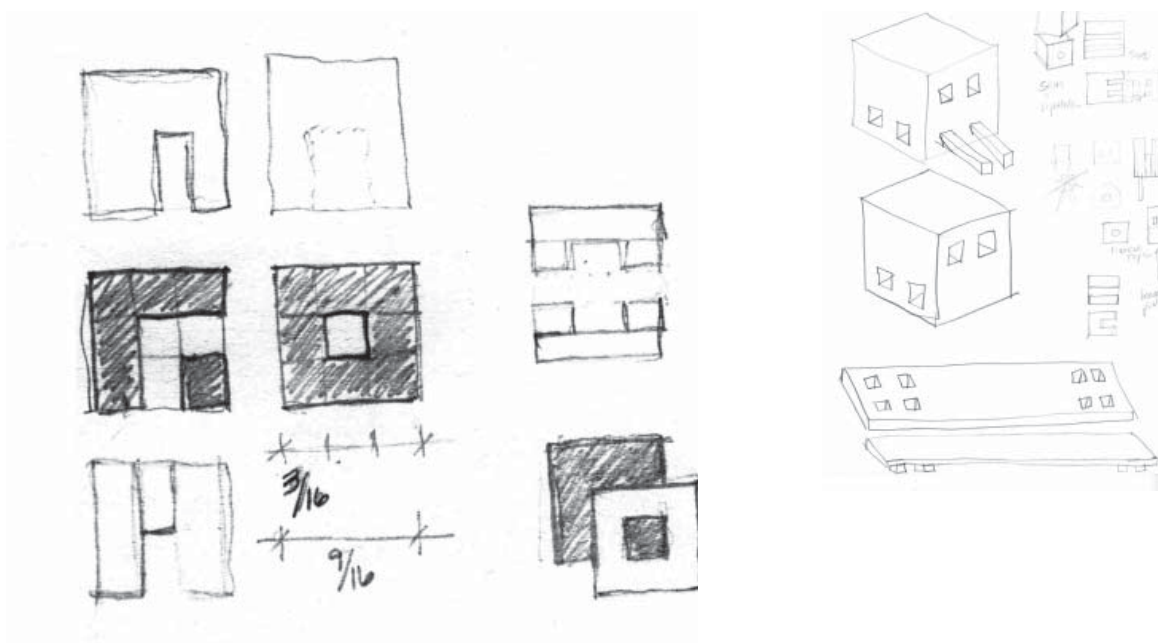

process

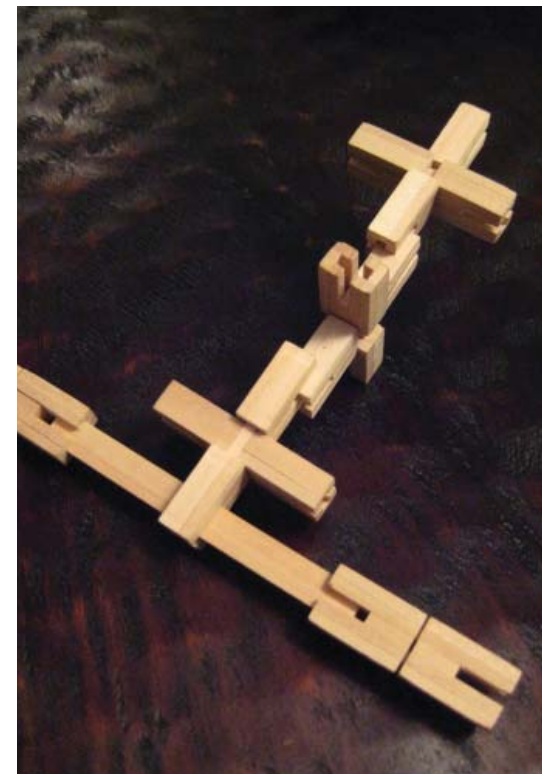
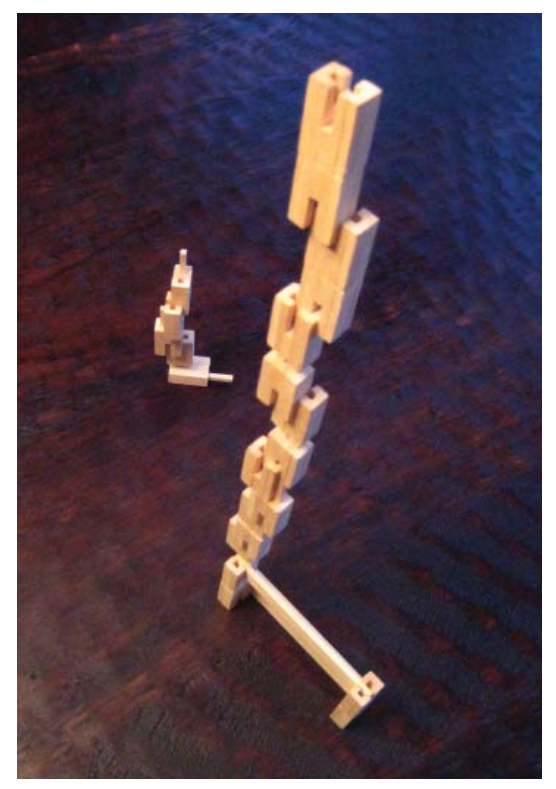
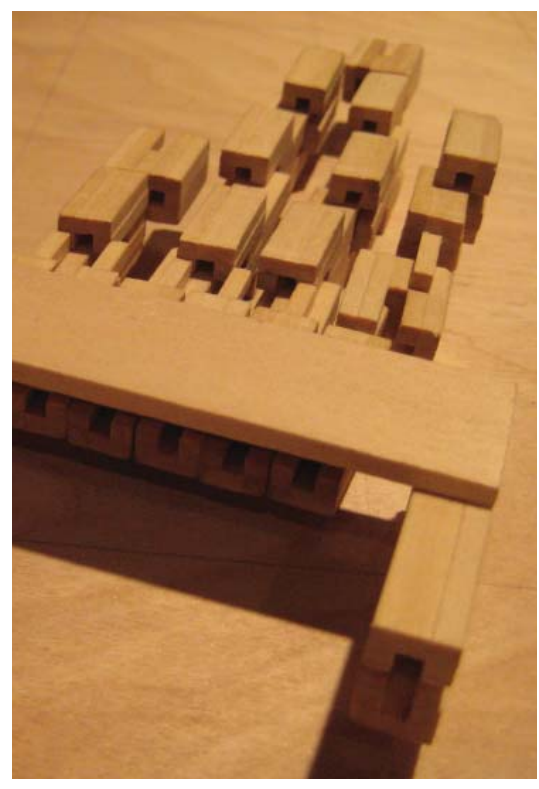
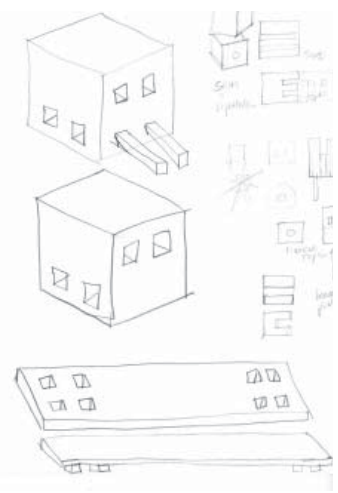
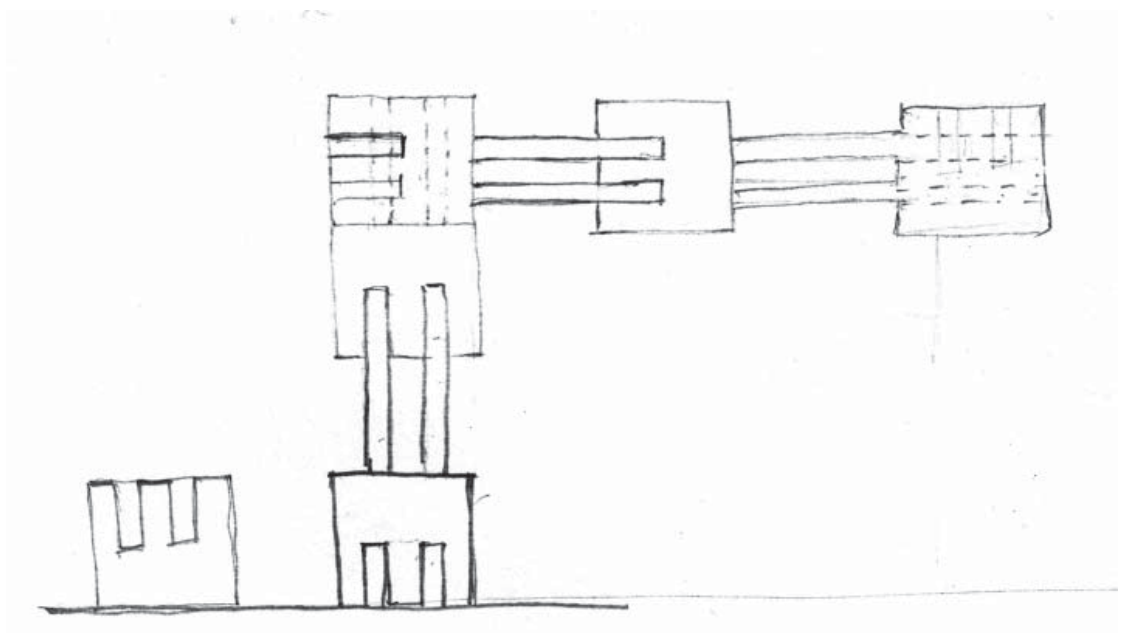

Dear Aunt Molly  
 Just incase I couldn't tell  
 you this is a bed case  
 thing you know those um  
 Metal things that go around  
 the bed, a canape type thing  
 Luv ya hope it makes  
 you lots of money  
 Margaret

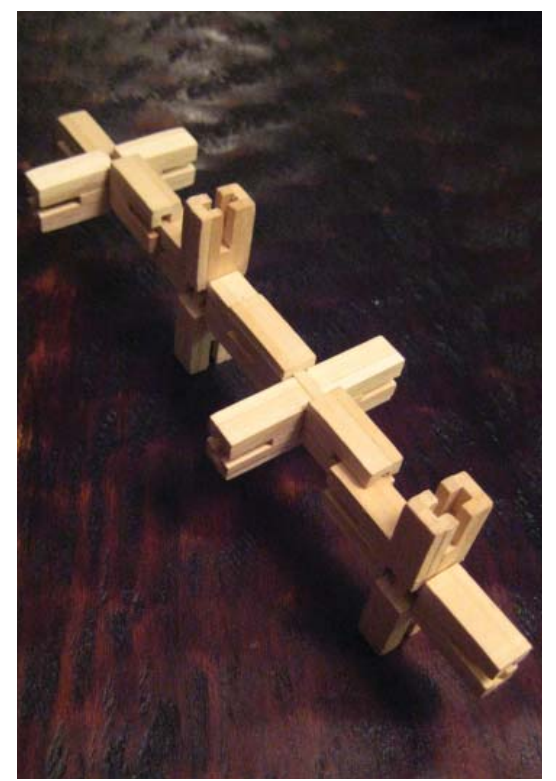
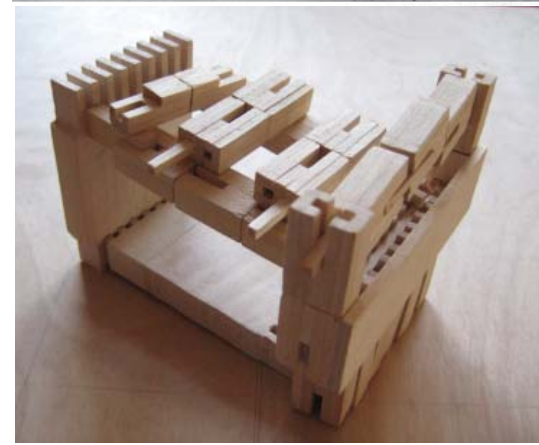

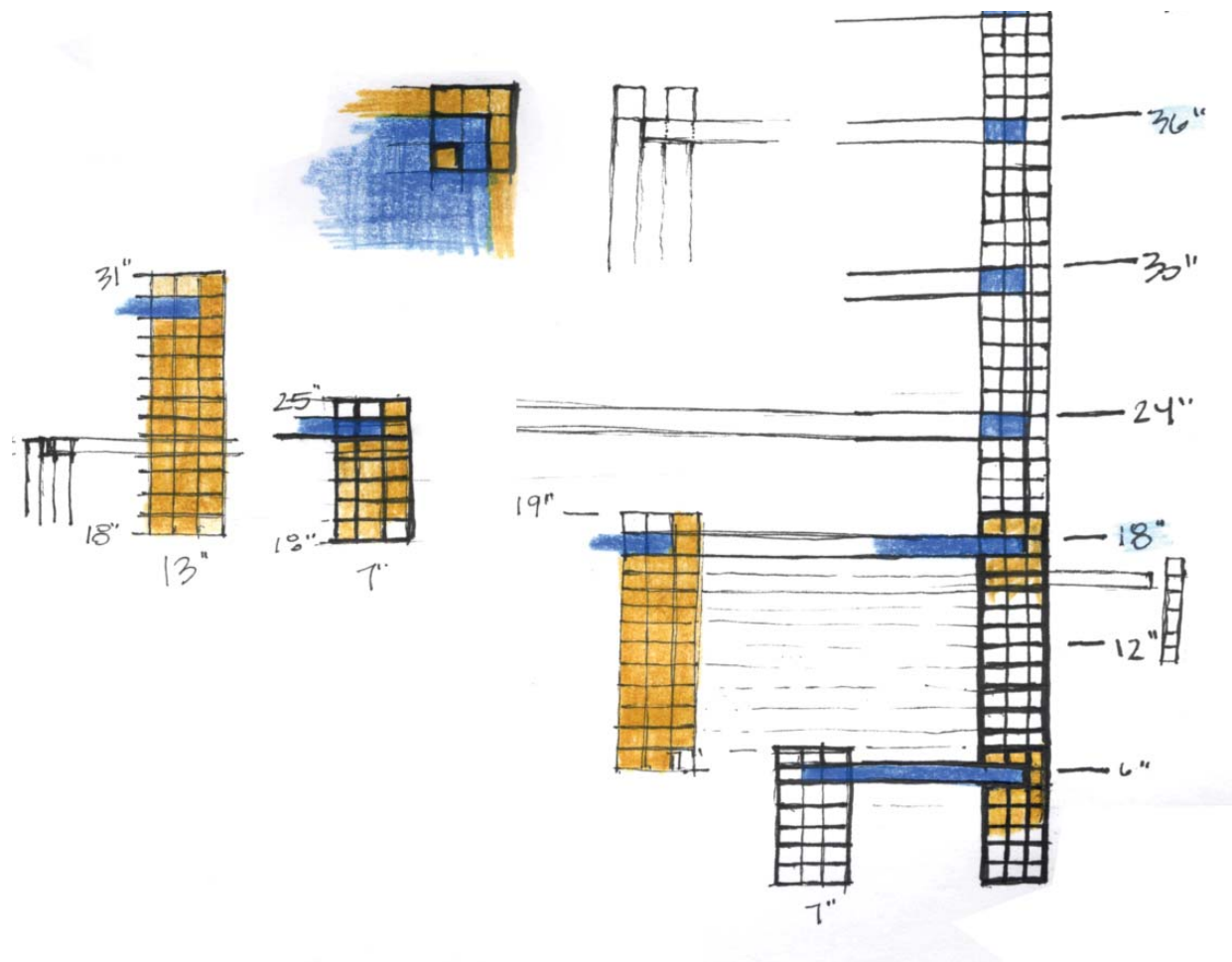

## process

The diagram below is a study of the height variations desired for heights of standard furnishings. 18" intervals transition something from chair to table. Heights in between are desired for desks, coffee tables, and end tables so 6" and 12" transitions are also needed. These options are also good for custom shelving units.

STANDARD		SEATED	
44"	TOP OF SEATING	44"	TOP OF SEATING
42"	TOP OF SEATING	42"	TOP OF SEATING
40"	TOP OF SEATING	40"	TOP OF SEATING
38"	TOP OF SEATING	38"	TOP OF SEATING
36"	TOP OF SEATING	36"	TOP OF SEATING
34"	TOP OF SEATING	34"	TOP OF SEATING
32"	TOP OF SEATING	32"	TOP OF SEATING
30"	TOP OF SEATING	30"	TOP OF SEATING
28"	TOP OF SEATING	28"	TOP OF SEATING
26"	TOP OF SEATING	26"	TOP OF SEATING
24"	TOP OF SEATING	24"	TOP OF SEATING
22"	TOP OF SEATING	22"	TOP OF SEATING
20"	TOP OF SEATING	20"	TOP OF SEATING
18"	TOP OF SEATING	18"	TOP OF SEATING
16"	TOP OF SEATING	16"	TOP OF SEATING
14"	TOP OF SEATING	14"	TOP OF SEATING
12"	TOP OF SEATING	12"	TOP OF SEATING
10"	TOP OF SEATING	10"	TOP OF SEATING
8"	TOP OF SEATING	8"	TOP OF SEATING
6"	TOP OF SEATING	6"	TOP OF SEATING

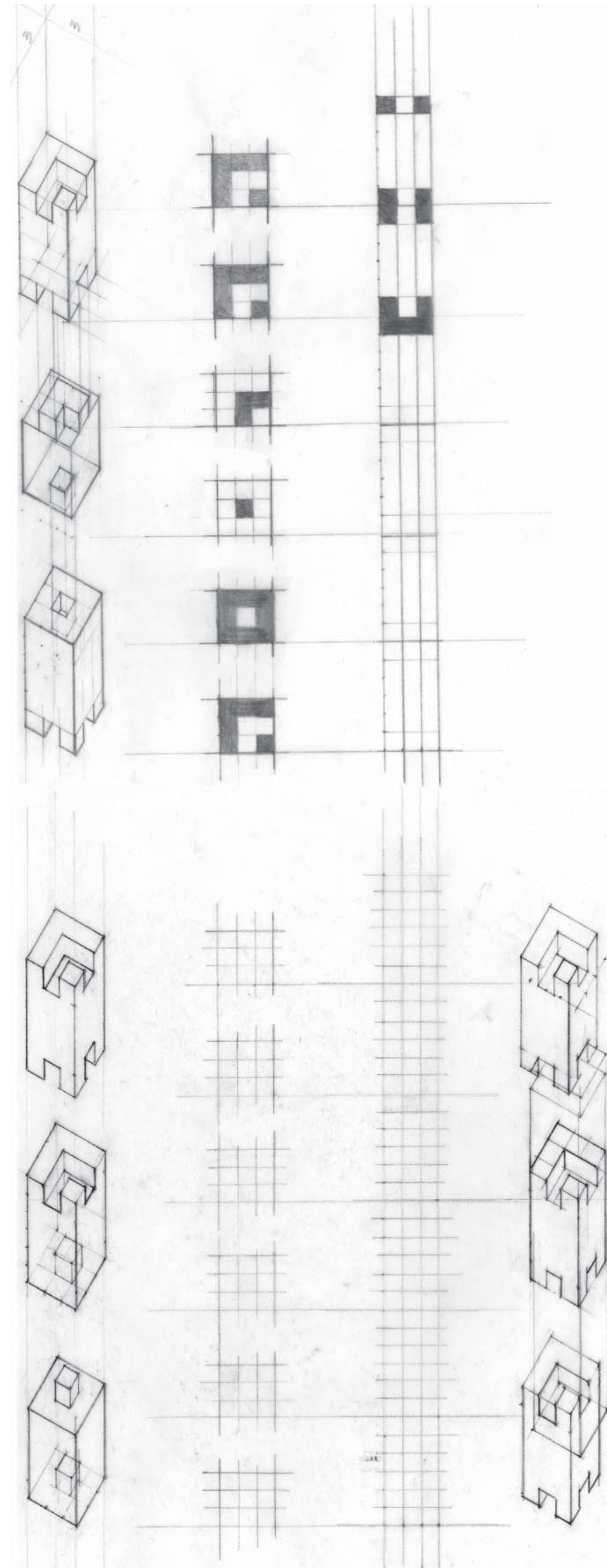

## mod 3



## process

Models were initially built and then the program Sketch-up was used to study possible variations of the design. The computer program provided quick responses to new ideas, much less time than waiting for glue to dry.

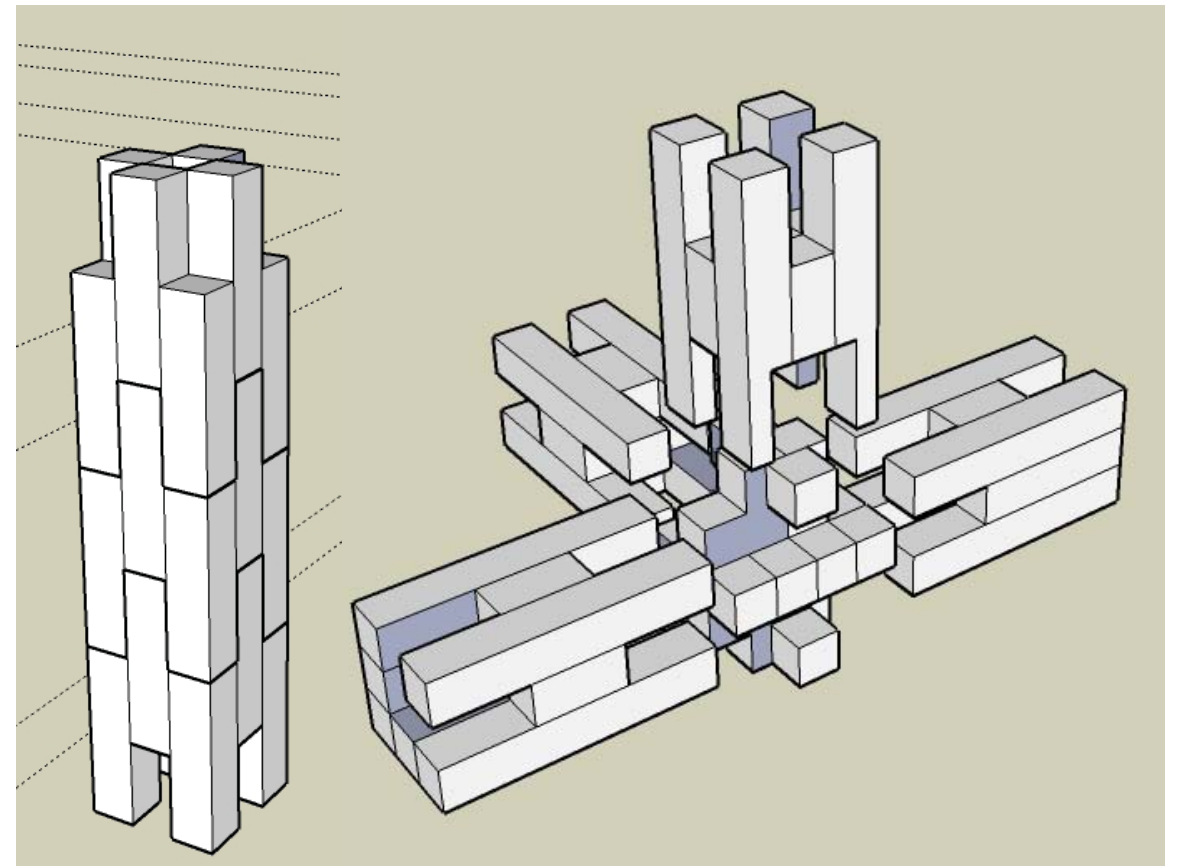
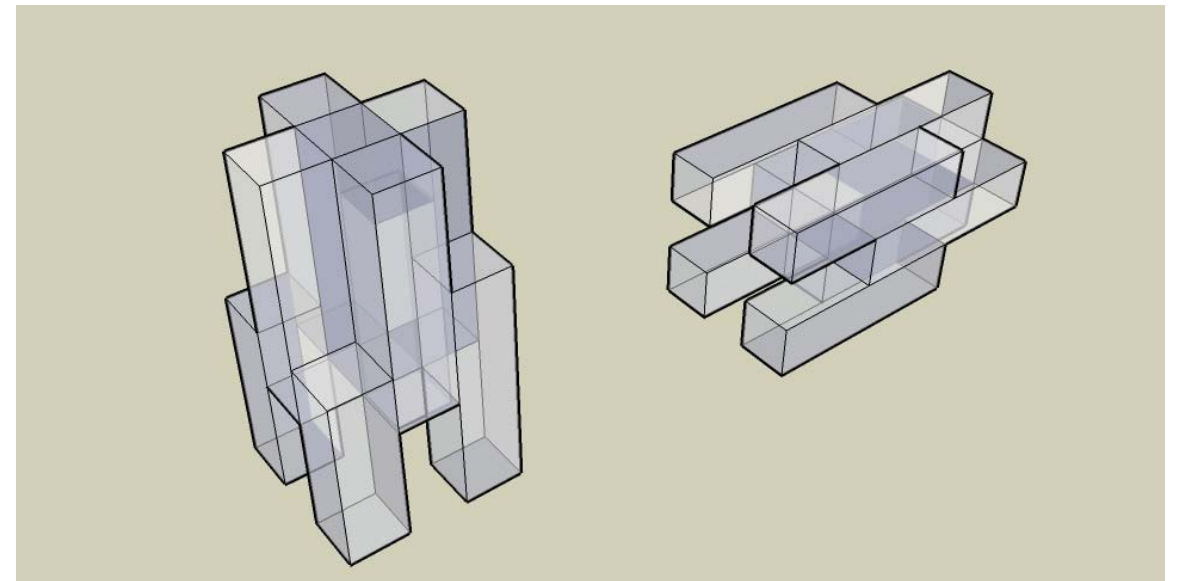

## mod 3

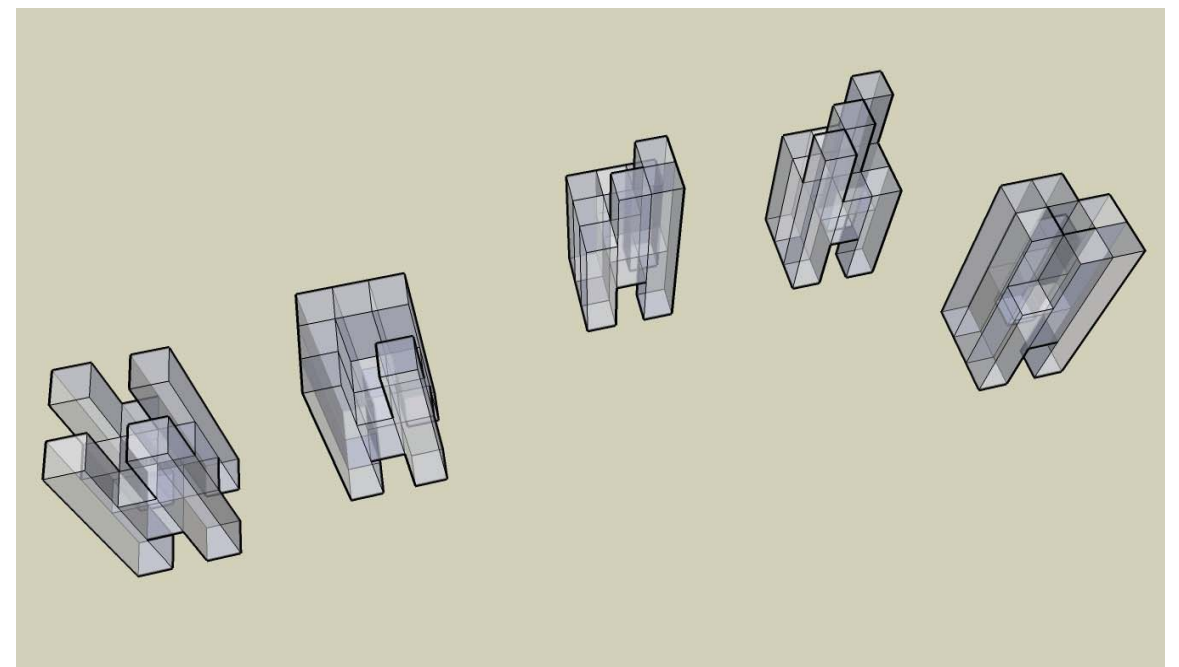

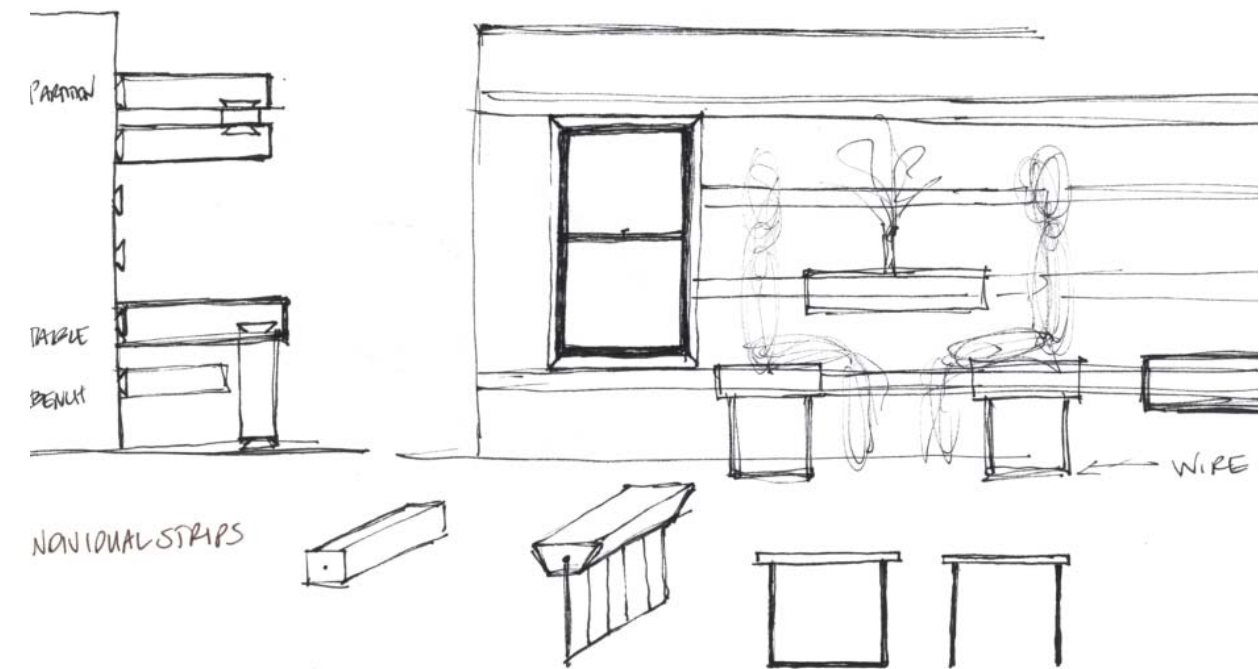
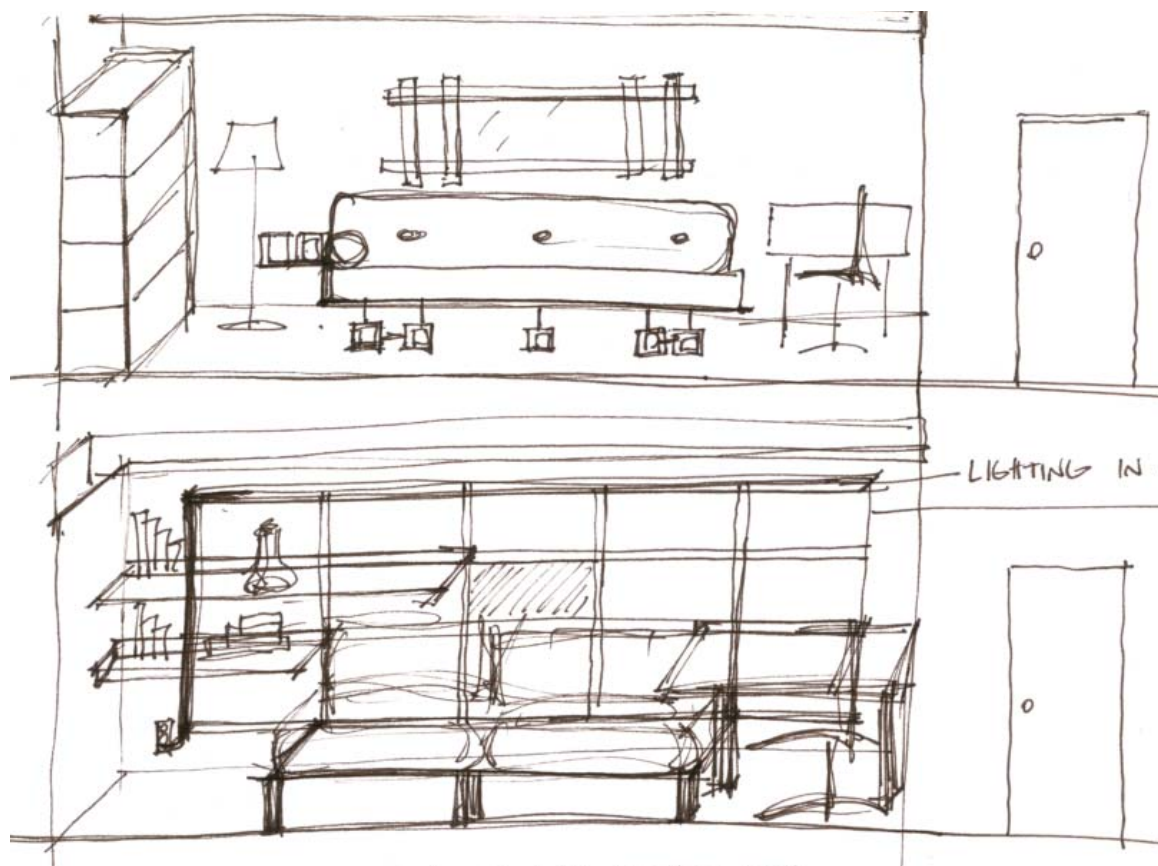

## process

The question was raised "how does this unit talk to the building," by Camden Whitehead. "How does it become a part of the structure?"

These sketches are studies of options for structural support. Bracing is required for most objects built with the MODs so these drawings look to the structure for help. Strips are fastened to the wall so shelves can be supported in the back by the wall and the front by the MODs. This provides the ability to build up and prevent racking. When the strips are not being used they would simply look like decorative moulding.

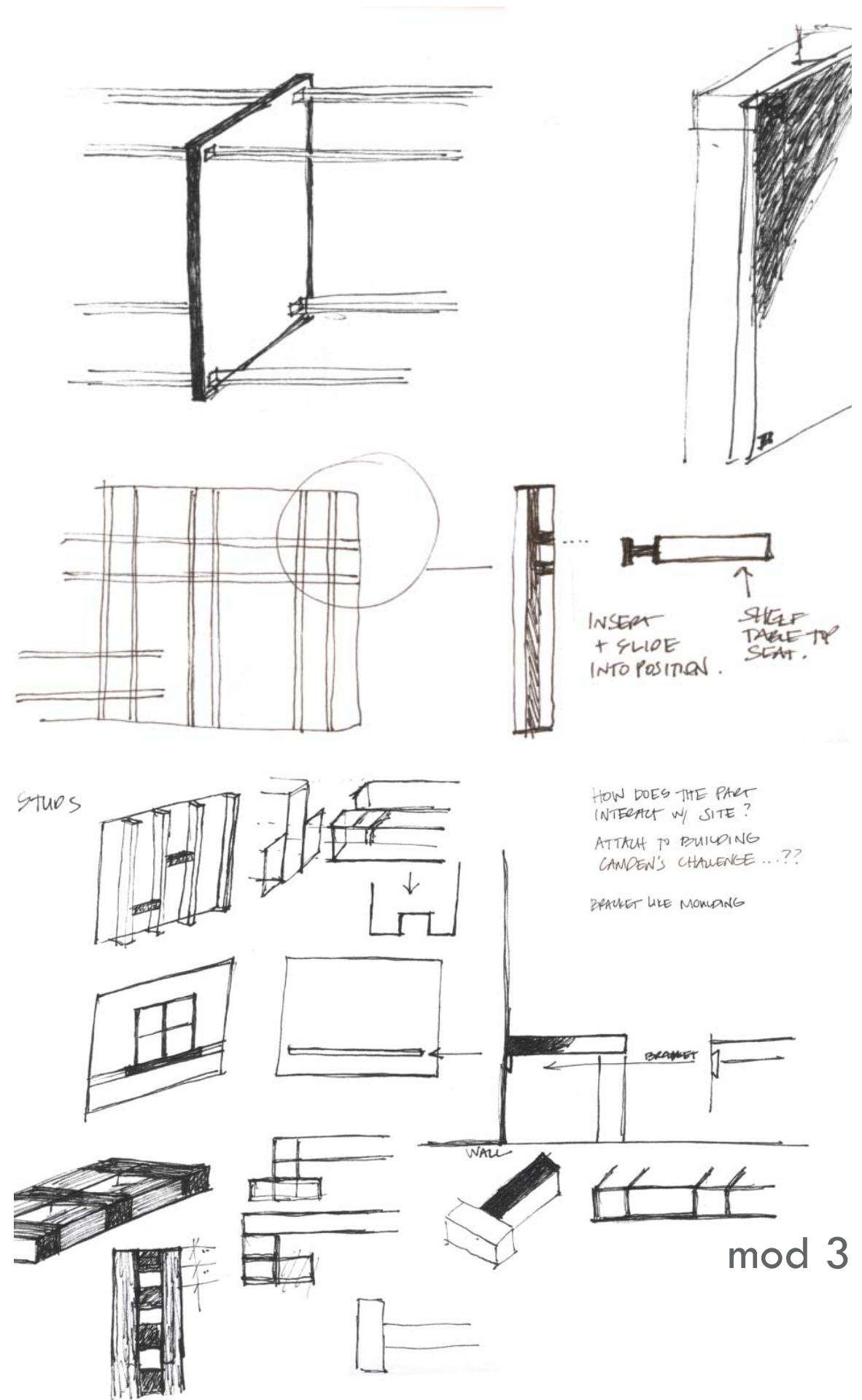

mod 3

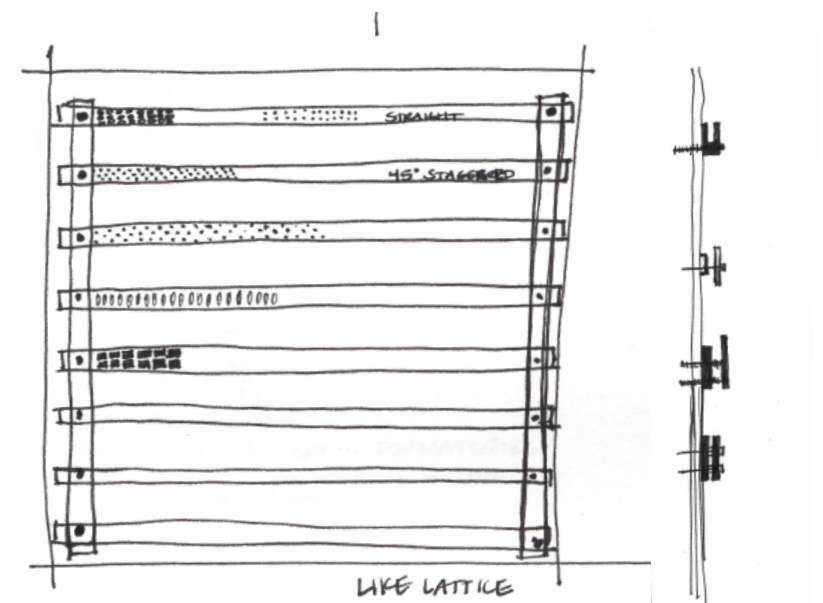

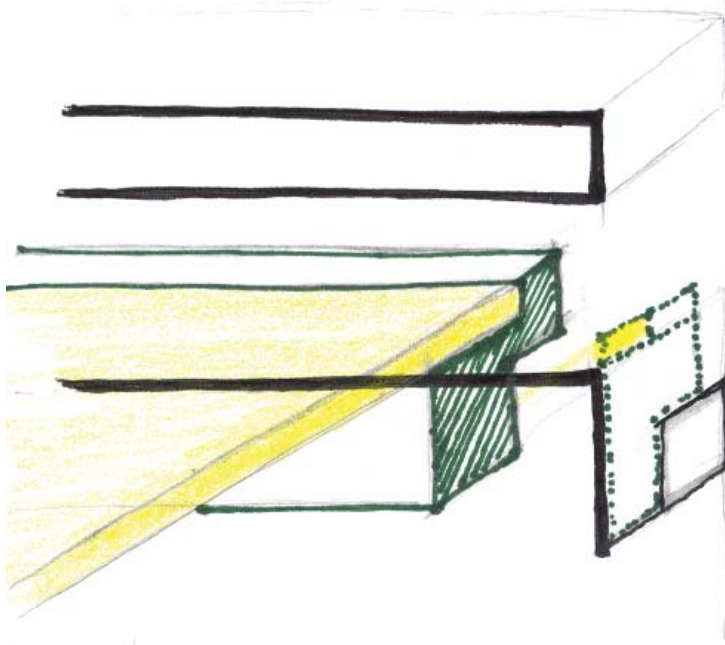
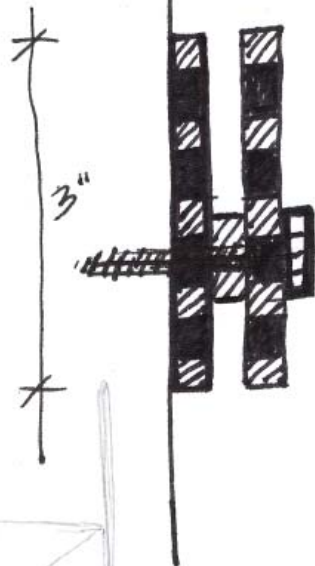
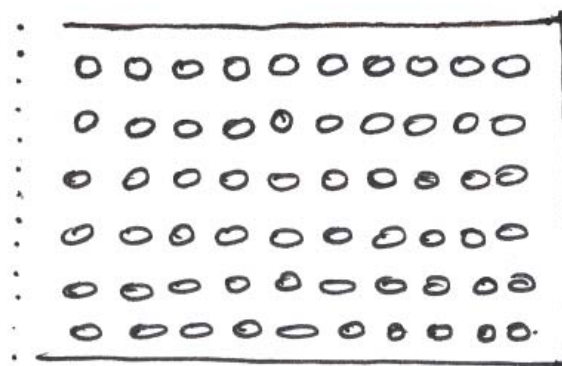
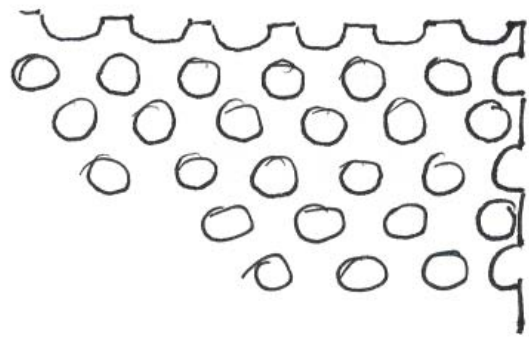

process

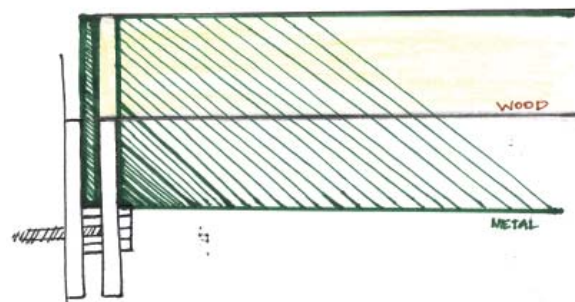

↑ TOLERANCE - HOW TIGHT?

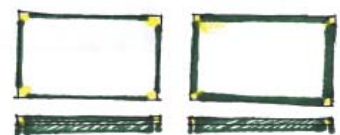

1 1/2

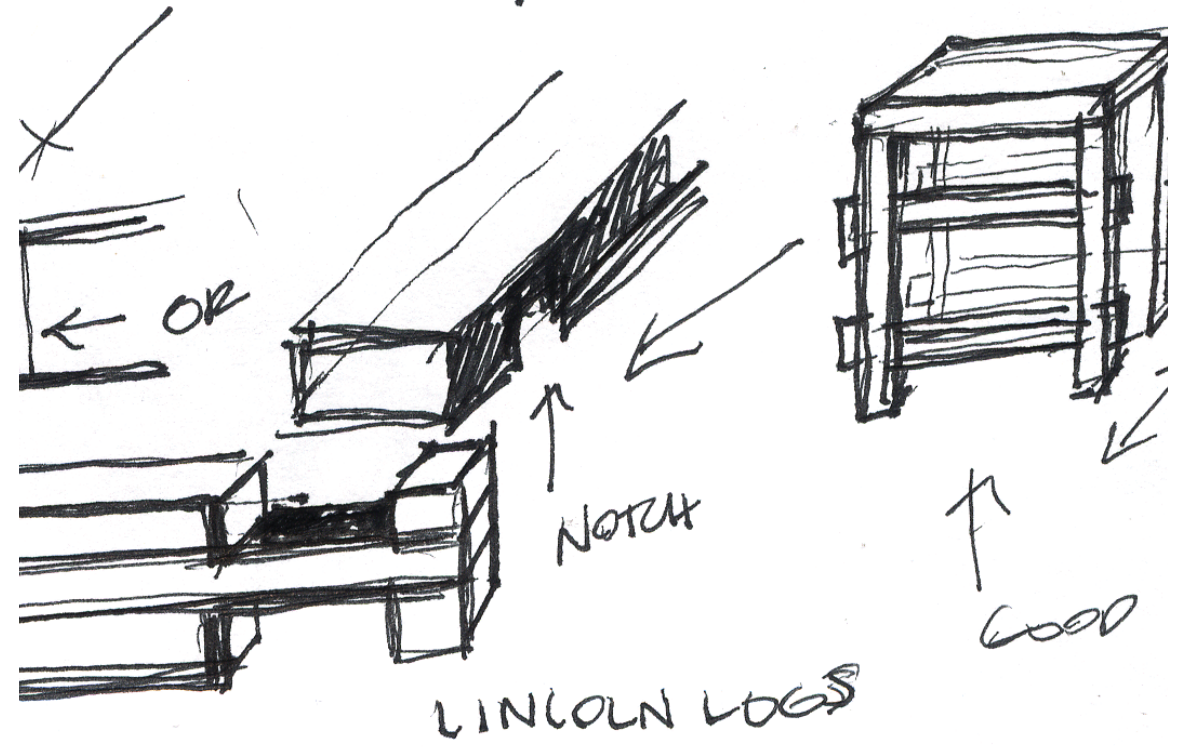

LINCOLN LOGS

mod 3 and 2 revisited

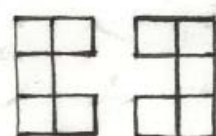
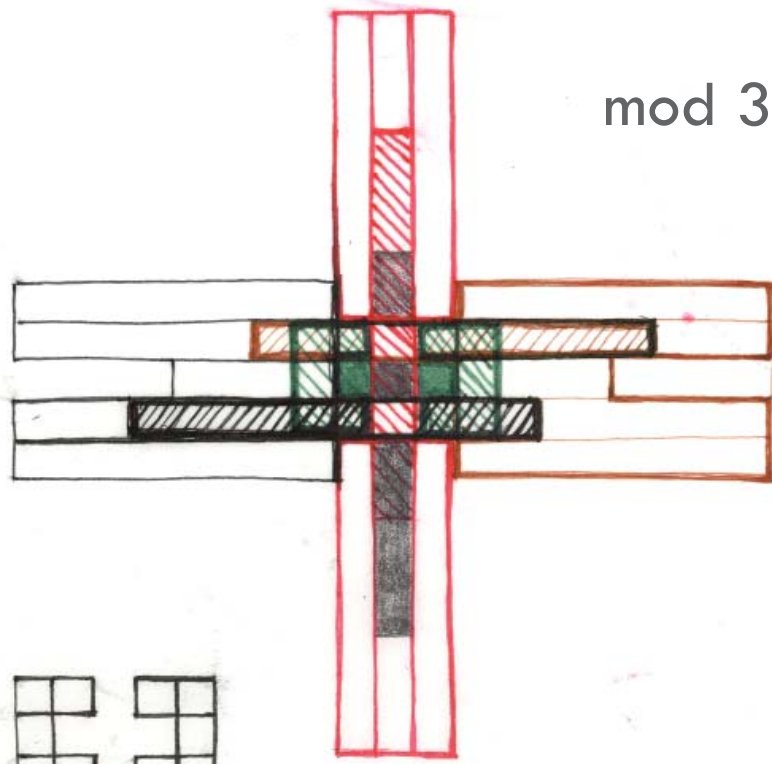



## presentation boards

The MFA Thesis Exhibition was held at the Anderson Gallery April 25th through May 4th. Each student was required to present 6 presentation boards 24"x36" illustrating our year of study.

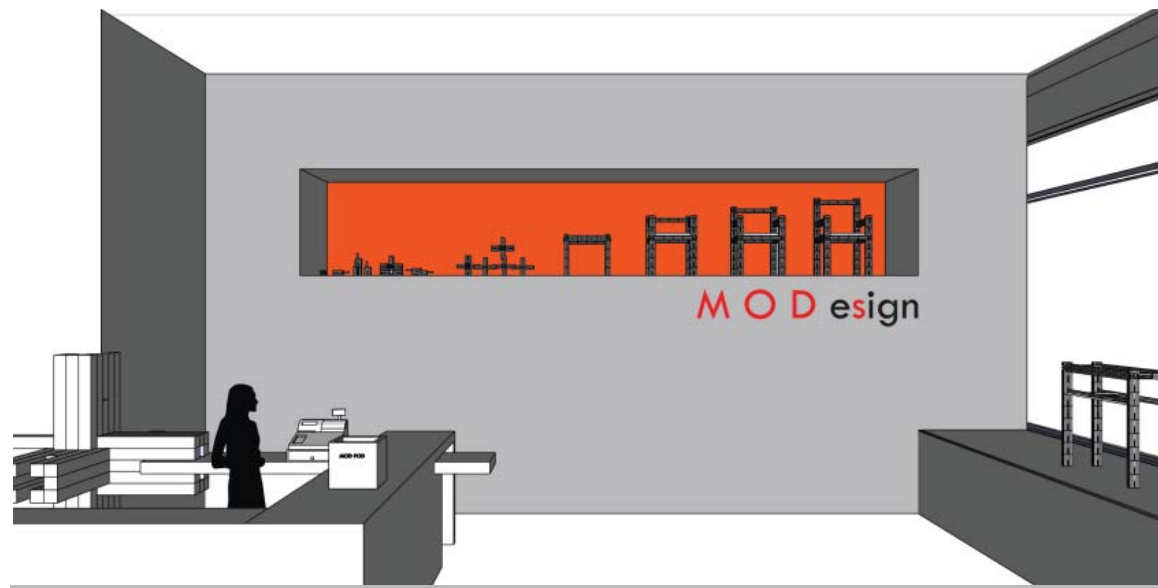

MO Design is a retail space that distributes MODs. Products can be purchased directly off the shelf as individual pieces or in MOD Pods that come with parts and directions for building a specific piece. Customers can also meet with the design staff at a set hourly rate to develop custom objects or plan environments

COMMERCIAL SPACE: MO Design



This space was designed for a senior couple e.g. Ray and Charles Eames. The first floor location is ideal for accessibility and the loft areas are convenient when their grandchild visits. With a wealth of furniture in their personal collection, they use their MODs for an end table next to their lounge chair and a console table for the narrow hall. The back wall is a custom shelving unit for books and tchotchkies.

APT 101: SENIOR COUPLE

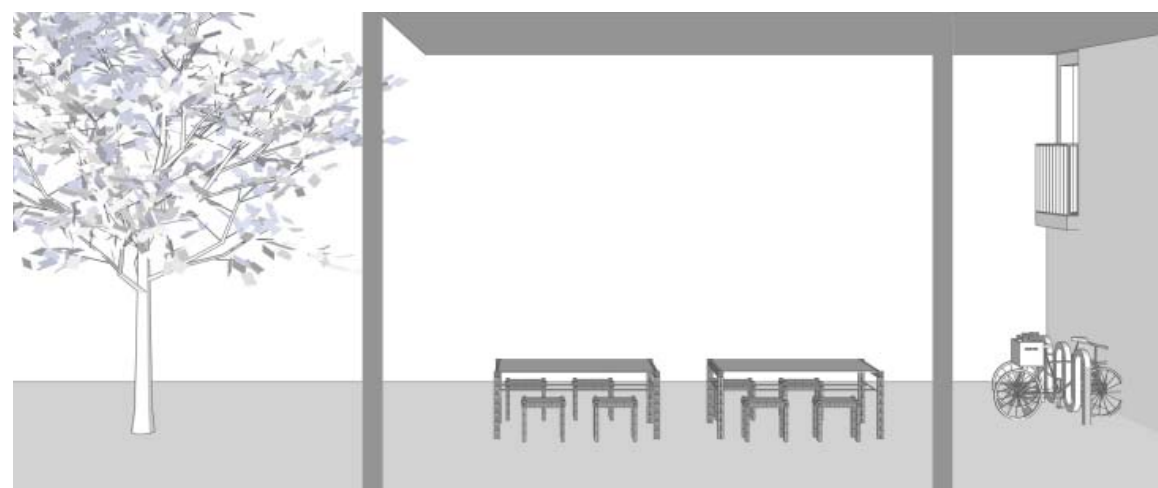

The back third of the first floor is open for car or bike storage. It is shown here as a community area for the occupants of the building. Aluminum MODs were specified for this space because of their resistance to weather.

EXTERIOR SPACE



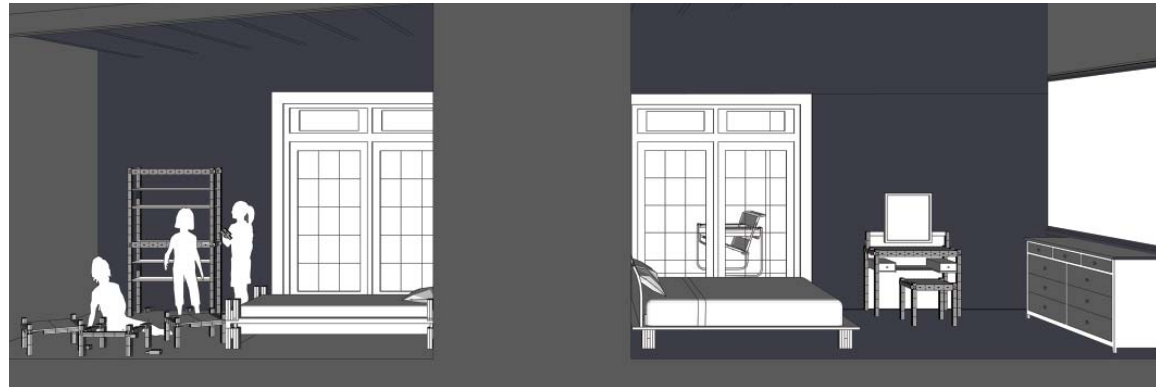

APT 201: COUPLE WITH SMALL CHILD

One of the two bedroom apartments is the home of a young couple with their first child. Bobby is four so he has outgrown his crib and is ready for a big boy bed. The new bed requires less parts so Bobby keeps the extra pieces in his room to build play things with his friends.

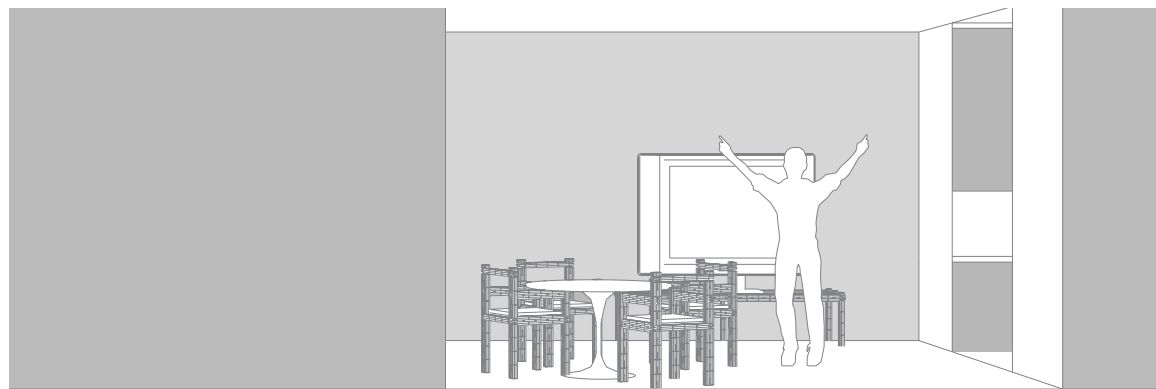

APT 202: YOUNG PROFESSIONAL MALE

Jim is a single, young professional who is attempting to rid his space of college furniture. He has purchased his first table for dining and for his weekly poker games. He built chairs with his MODs. They double as seating for his friends when they come over to watch the big game on his main priority—the big-screen TV. He used MODs to support his TV and audio equipment as well.

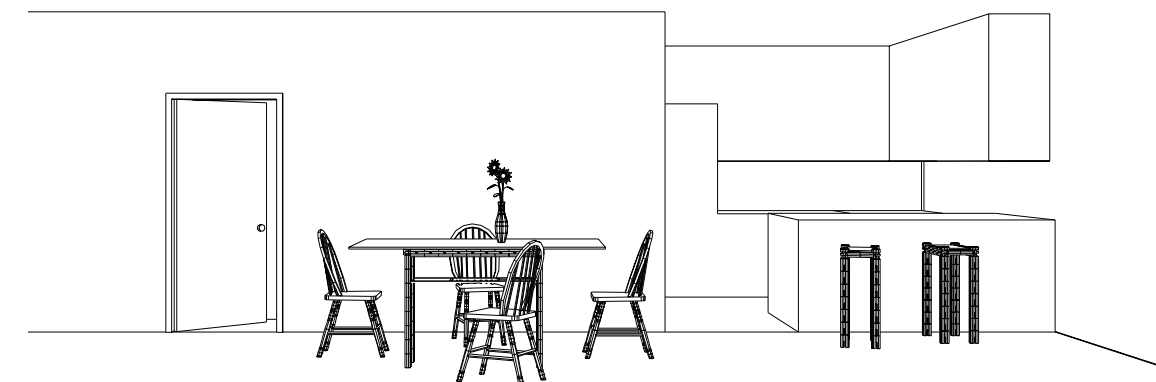

APT 203: YOUNG PROFESSIONAL FEMALE

Sally is also a single, young professional who enjoys entertaining. She built an oversized table for the dinner parties she hosts for her friends. The chairs were her mothers so she can't bear to throw them out... yet.

Josie and Jane are studious college students who spend a lot of time in their private spaces reading, researching, and relaxing. Josie's bedroom has the necessities but she prefers spending time in the living room in her Papasan chair. Jane has designed her own custom four-poster bed with a canopy. Jane also made a custom desk unit that contains built-in drawers, shelving and lighting.

APT 301: TWO FEMALE COLLEGE STUDENTS



Leo is a world renowned artist hiding out in Richmond, VA. He built a loft out of custom MOD units designed for the scale of his construction. His studio area can be reconfigured based on his creative needs whether he is painting or sculpting.

APT 302: ESTABLISHED MALE ARTIST

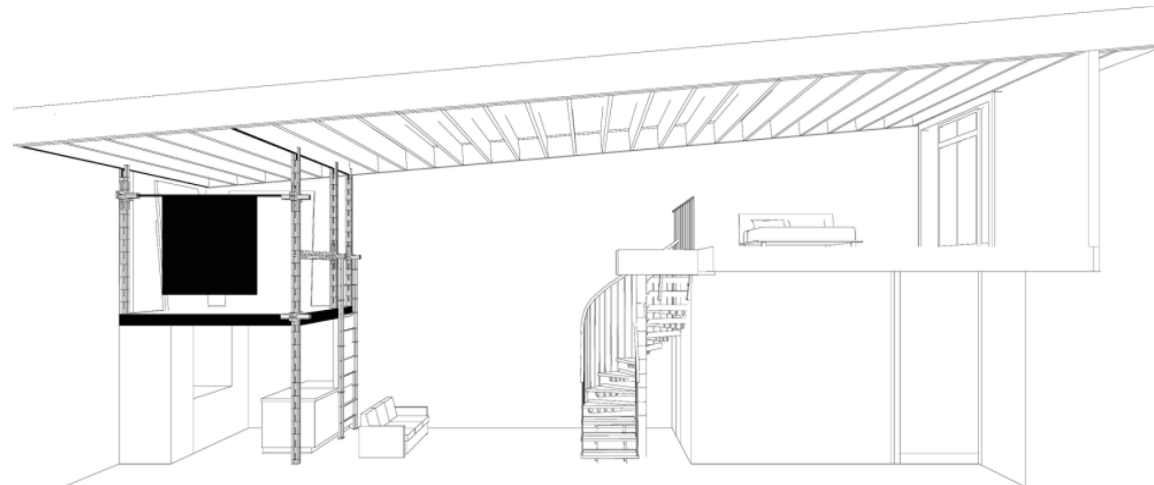

Barbara is an established professional who enjoys collecting designer furniture. She uses MODs as a substitute for items she isn't ready to purchase. Her MOD piece was originally a coffee table but when she purchased her Noguchi table she needed a new use for the MODs. She decided she would build a shelving unit to store the books currently stacked on her office floor.

APT 303: ESTABLISHED FEMALE

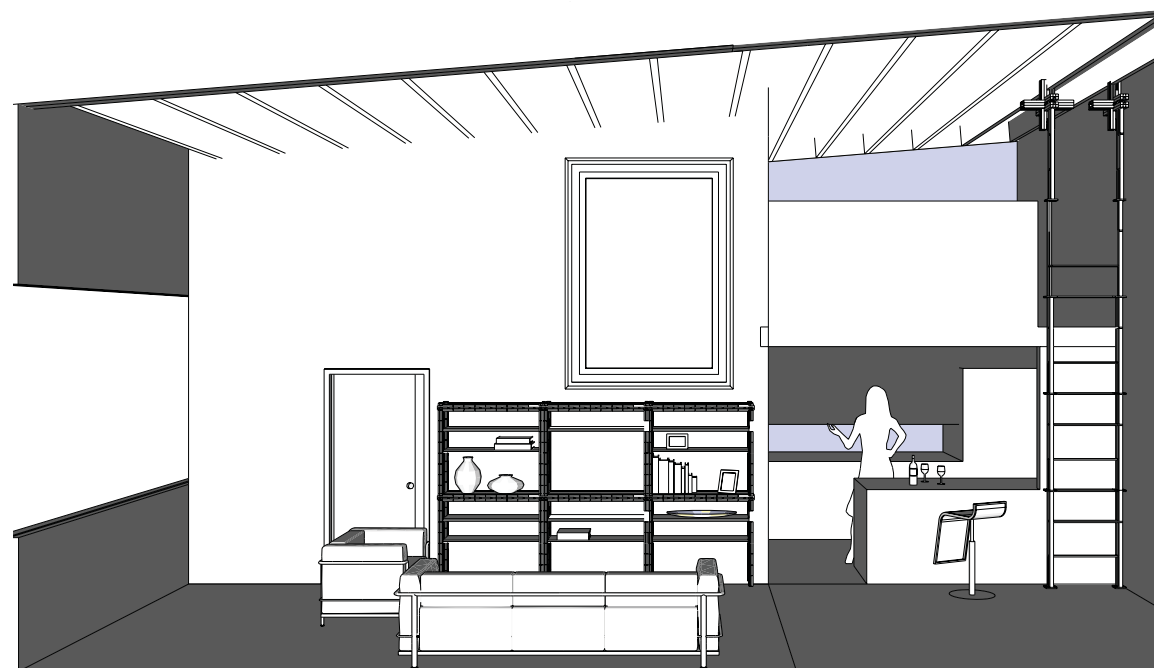

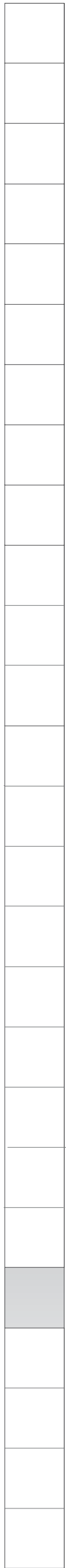

products

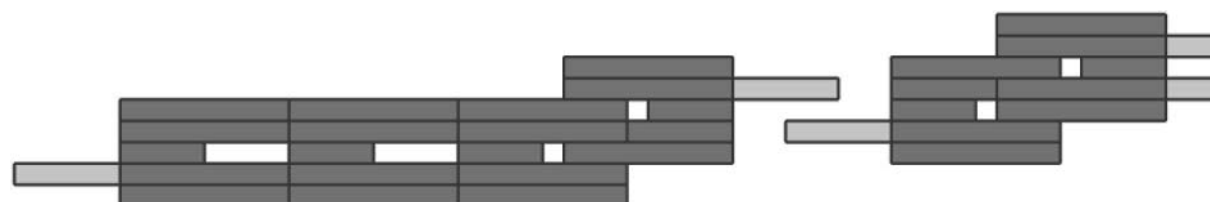

no design

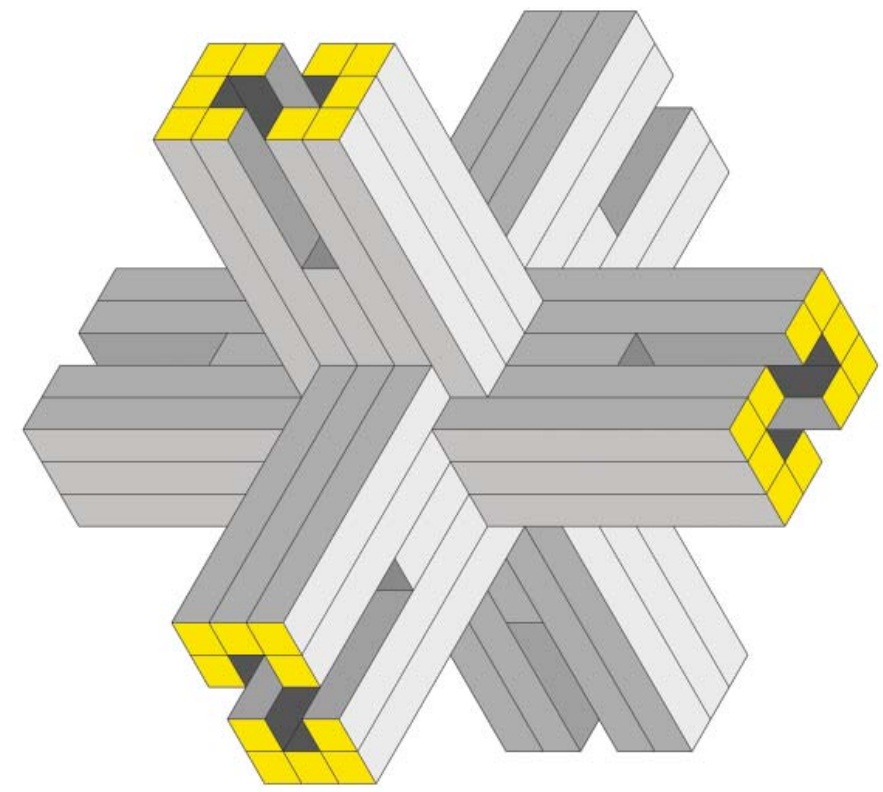
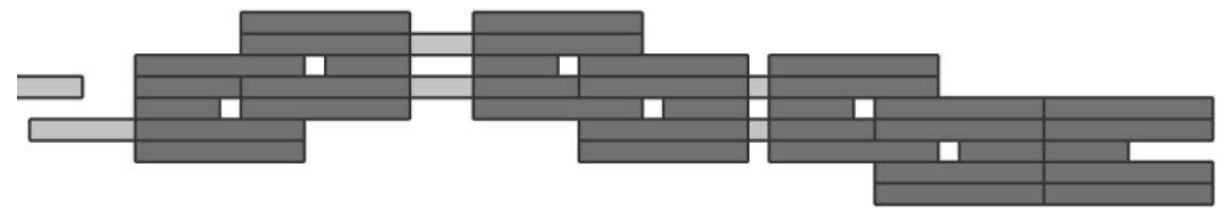

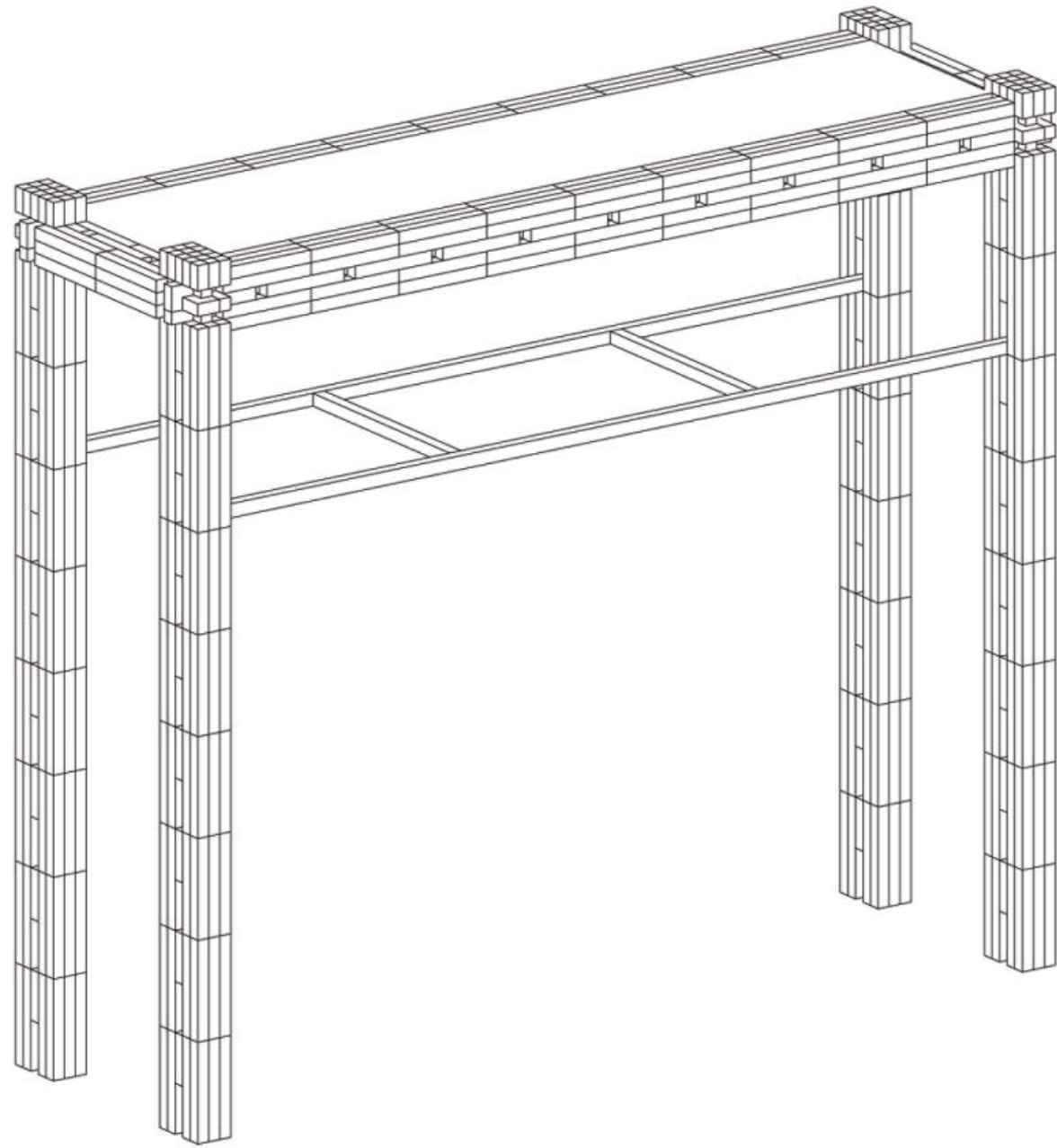

console table

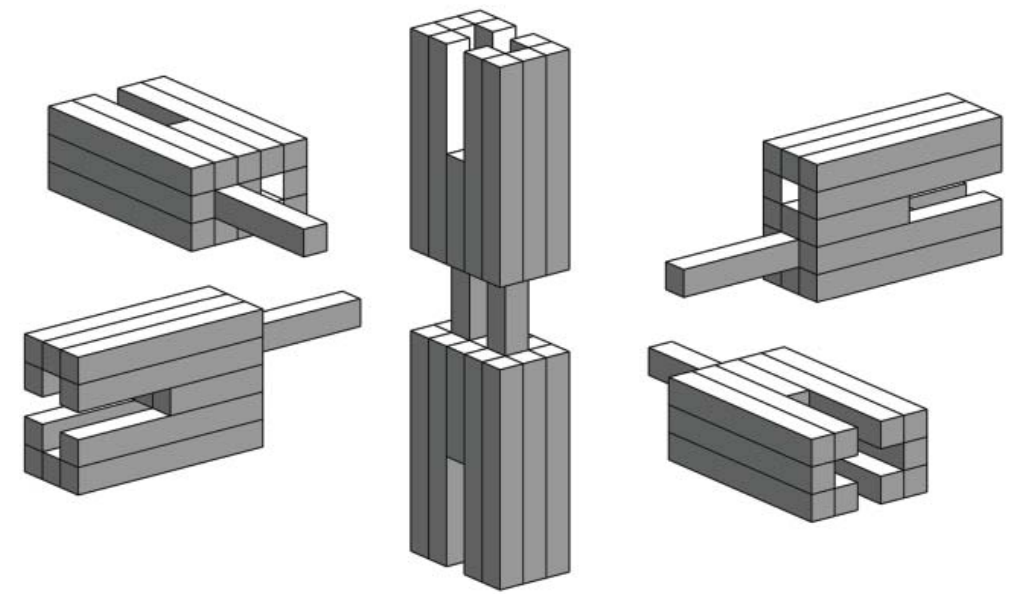

one piece repeated

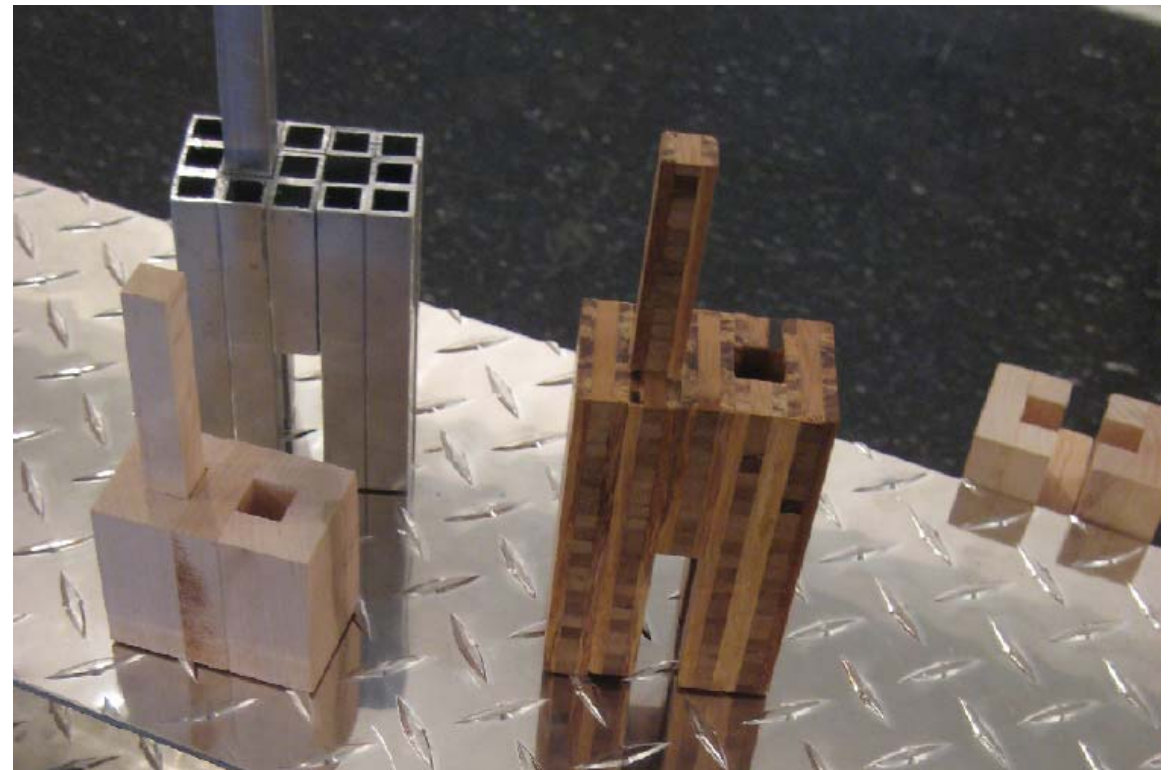
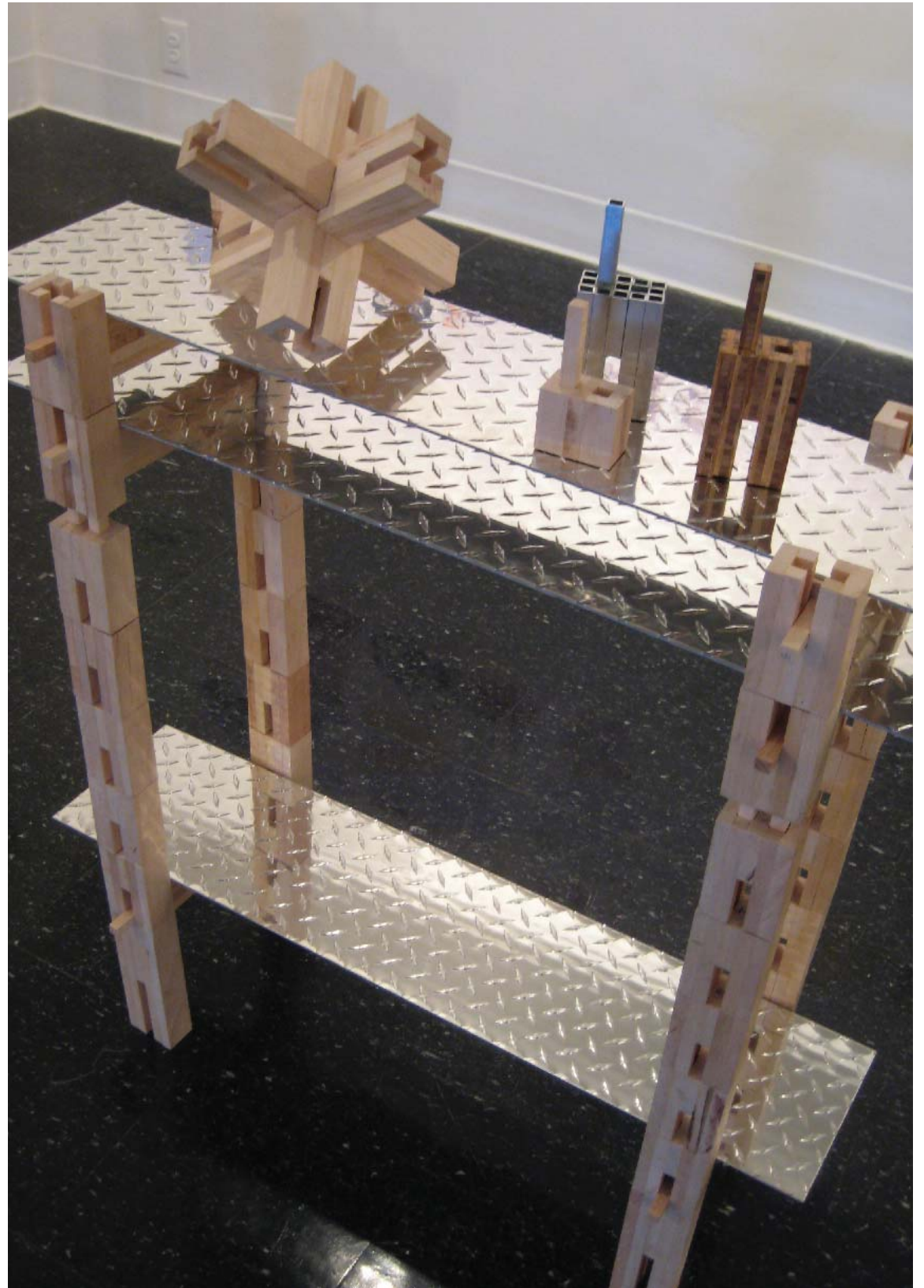



	text	images
1	Arieff, Allison. "How to Play FlatPak." Dwell. april/may 2005. Dwell. 5 May 2008 < <a href="http://www.dwell.com/homes/green/3830491.html">http://www.dwell.com/homes/green/3830491.html</a> >.	1
2	Blaser, Werner. "Joint and Connection." Basel: Birkhauser Verlag. 1992. 22-27;31;104-105.	2
3	Caillois, Roger. "The Definition of Play and The Classification of Games"	3
4	Citimove, LLC. 1 March 2008 < <a href="http://www.citimove.com/src/moverDetails.php?id=24">http://www.citimove.com/src/moverDetails.php?id=24</a> >.	4
5	DWR, "Charles and Ray Eames." Designers. 2008. Design Within Reach. 11 Mar 2008 < <a href="http://www.dwr.com/category/designers/d-g/charles-and-ray-eames.do">http://www.dwr.com/category/designers/d-g/charles-and-ray-eames.do</a> >.	5
6	Eames Office, "Vintage Eames." Eames Office Resource. 2006. Eames Office. 21 Nov 2007 < <a href="http://www.eamesoffice.com/vintage/vintage_intro.php?id=1">http://www.eamesoffice.com/vintage/vintage_intro.php?id=1</a> >.	6
7	Kiser, Kirsten. "MVRDV." arcspace.com. 07 February 2005. arcspace. 8 Dec 2007 < <a href="http://www.arcspace.com/architects/mvrdv/silodam_article.html">http://www.arcspace.com/architects/mvrdv/silodam_article.html</a> >.	7
8	Naomi. "Borneo Sporenburg." MIMOA. 2007. 8 Dec 2007 < <a href="http://www.mimoa.eu/projects/Netherlands/Amsterdam/Borneo%2520Sporenburg">http://www.mimoa.eu/projects/Netherlands/Amsterdam/Borneo%2520Sporenburg</a> >.	8
9	Neuhart, John. "Eames Design: The Work of the Office of Charles and Ray Eames." New York: Harry N. Abrams, Inc., 1989: 8-15.	9
10	Pogrebin, Robin. "Couples Who Build More Than Relationships." The New York Times. 22 April 2007 < <a href="http://www.nytimes.com/2007/04/22/arts/design/22pogr.html?_r=2&amp;pagewanted=1&amp;ref=arts&amp;oref=slogin">http://www.nytimes.com/2007/04/22/arts/design/22pogr.html?_r=2&amp;pagewanted=1&amp;ref=arts&amp;oref=slogin</a> >.	10
11	Salen, Katie and Zimmerman, Eric. The Game Design Reader: A Rules of Play Anthology. Cambridge, Massachusetts: The MIT Press, 2006. 122-8; 296-301.	11
12	Salmon, Emily J., and John S. Salmon. Historic Photos of Richmond. Nashville, Tennessee: Turner Publishing Co., 2007.	12
13	Seike, Kiyosi. The Art of Japanese Joinery. New York: Weatherhill/Tankosha, 8th ed., 1977.	13
14	"Wikipedia." Industrial Revolution. 15 November 2007. Wikipedia Foundation, Inc.. 29 Dec 2007 < <a href="http://en.wikipedia.org/wiki/Industrial_revolution">http://en.wikipedia.org/wiki/Industrial_revolution</a> >.	
15	"Wikipedia." Lego Serious Play. 5 February 2008. Wikipedia Foundation, Inc. 31 January 2008 < <a href="http://en.wikipedia.org/wiki/Lego_Serious_Play">http://en.wikipedia.org/wiki/Lego_Serious_Play</a> >.	
16	"Wikipedia." Piet Mondrian. 7 May 2008. Wikipedia Foundation, Inc.. 7 May 2008 < <a href="http://en.wikipedia.org/wiki/Piet_Mondrian">http://en.wikipedia.org/wiki/Piet_Mondrian</a> >.	
17	"Wikipedia." Thalhimers Brothers. 5 December 2007. Wikipedia Foundation, Inc.. 9 Dec 2007 < <a href="http://en.wikipedia.org/wiki/Thalhimer%27s">http://en.wikipedia.org/wiki/Thalhimer%27s</a> >.	