

A study of the high resolution jet chamber

その他（別言語等） のタイトル	高分解能ジェットチェンバーの研究
著者(英語)	Yousuke Yamashita, Masao Ogawa
journal or publication title	Bulletin of the Nippon Dental University. General education
volume	17
page range	47-54
year	1988-03-20
URL	http://doi.org/10.14983/00000327



A Study of the High Resolution Jet Chamber

Yousuke YAMASHITA

Physics Laboratory, The Nippon Dental University,
Hamaura-cho 1-8, Niigata 951, JAPAN

Masao OGAWA

Department of Physics, Niigata University,
8050 Ninomachi, Ikarashi, Niigata 950-21, JAPAN

(Received December 9, 1987)

Abstract

We have measured a spatial resolution of the jet chamber which have a new geometry. The measurement was originally motivated to help designing a new type of detector for $e^+ e^-$ colliding experiment.

Introduction

High precision drift chambers have played an important part in high energy experiments [1]. The test chamber were originally designed as a new type detector for $e^+ e^-$ collider experiment at KEK [2], in order to detect synchrotron radiation X-rays generated by electrons passing through a high magnetic field. However the geometry (short distance between wires) of the jet chamber made so difficult technically and unstable in operation, that the actual installed chamber in the KEK detector has different geometry. The test chamber is worth studying its characteristic properties because the advantage of efficiency and high resolution are expected. In this paper we report the result of a test experiment.

Experimental apparatus

2.1 Jet chamber and gas system

The test chamber shown in fig. 1 has a signal wire plane which is sur-

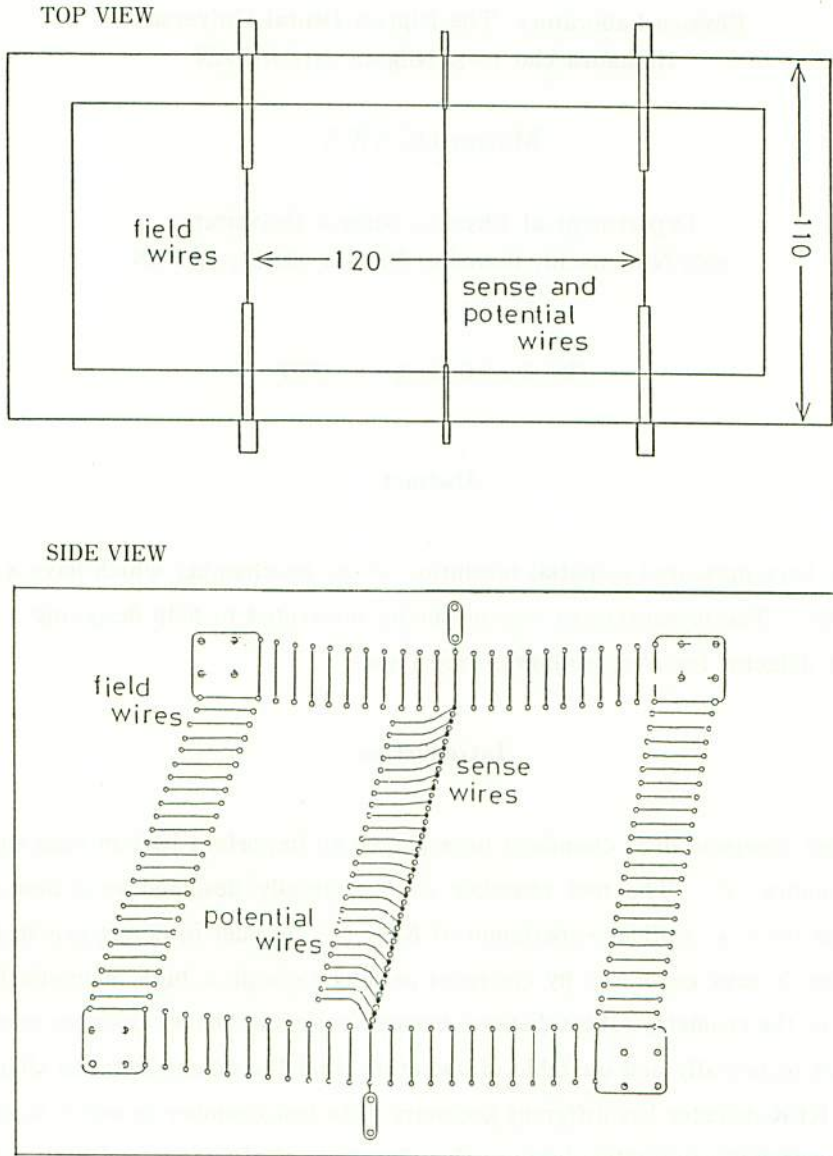

Fig. 1 Geometry of the test jet chamber.

rounded with many field wires. The wire plane consists of alternating sense wires and potential wires with a 2 mm spacing and tilt 15 degrees to compensate the effect of the Lorentz angle at high magnetic field of 3 T [2]. The sense wires are 30 μm gold-plated tungsten and tensed to 105 g. The potential wires are 70 μm gold-plated tungsten and tensed to 150 g. The field wires are 140 μm gold-plated Mo and tensed to 200 g. Each wire was soldered into a metal tube which was the inside of a plastic feedthru. All the feedthrus were held in two endplates using RTV silicone rubber to form the gas seal. The endplates are on both side of wires and constructed from precisely drilled 10 mm thick aluminum plates.

The four sides of the chamber except for two wire endplates were made of aluminum plates with Mylar windows. The chamber has been filled with PR gas which gives a saturated drift velocity near 4 cm/ μ sec [1]. A gas supply system is shown schematically in fig. 2. Moreover, the jet chamber was put on proportional drift chambers consisting of six layers (each layer consisting of 6 or 7 tubes) which are not used in this paper [3].

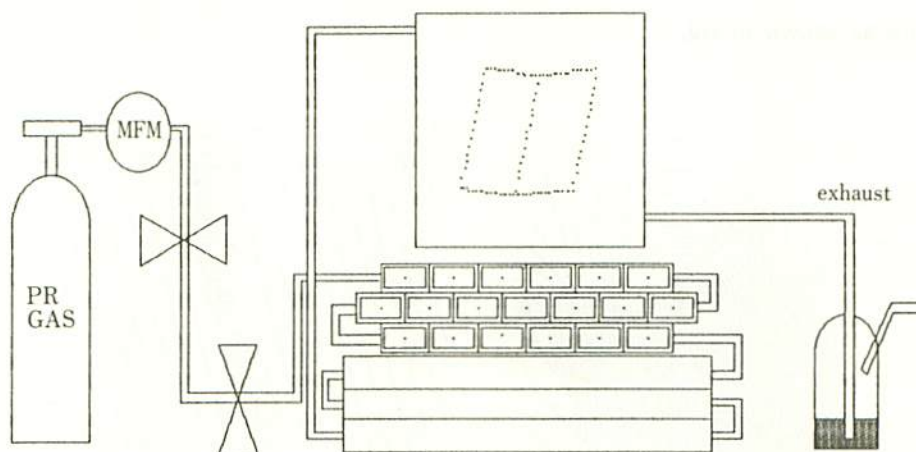

Fig. 2 Schematic for the gas supply.

2.2 Electronics and data acquisition

A schematic for the electronics for one sense wire is shown in fig. 3.

The positive high voltage was applied on the sense wires using Teflon coaxial cables. The potential wires were at ground. The negative high voltage were

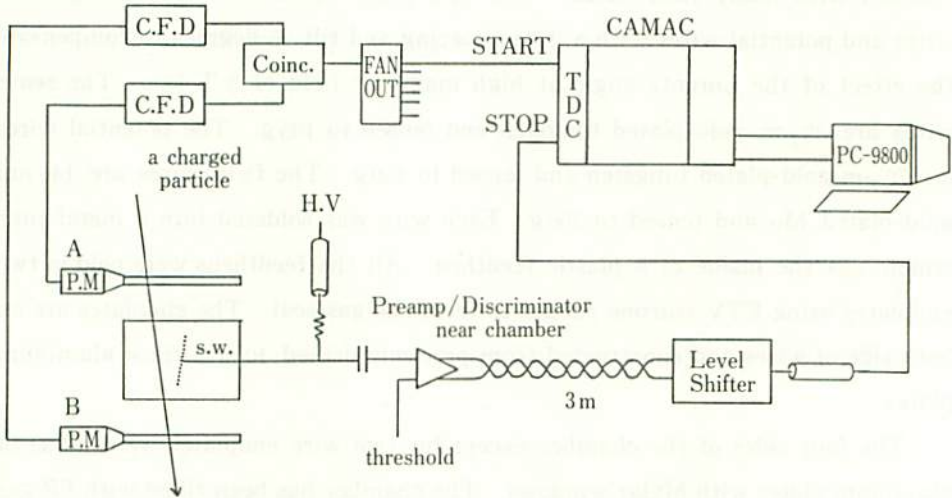

Fig. 3 Block diagram of the readout electronics for the jet chamber.

applied on field wires using a bleeder resistor board in order to make the field running parallel to the sense wire plane. The computed field is shown in fig. 4. The test have been performed at Niigata University with cosmic-rays and a setup as shown in fig. 5.

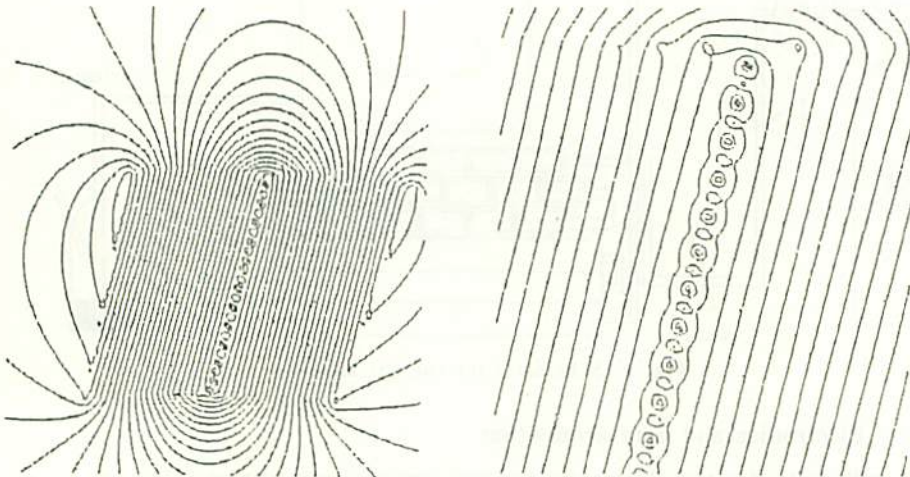

Fig. 4 Equipotential surfaces and expanded figure near the sense wires.

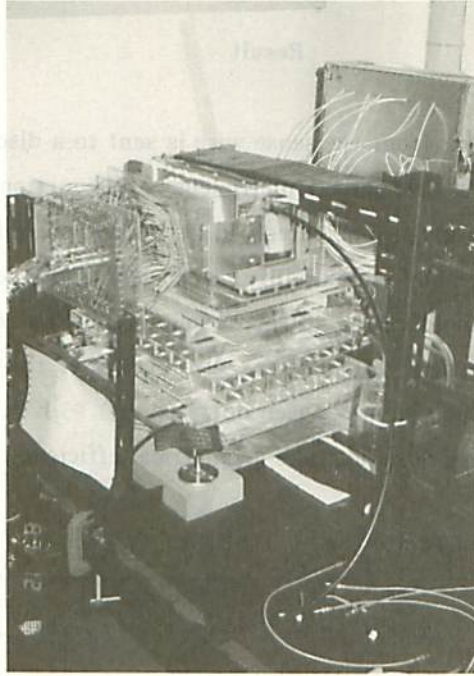

Fig. 5 The detector with the test jet chamber.

When a charged particle traversed apparatus from up to down, a signal of a plastic scintillator was generated. The trigger were generated by a coincidence of scintillation counters A and B. The trigger signal were sent to TDC (Time/Digital Converter) as START signal. While the sense wire signal which was generated by a cluster of drifted electrons from the charged particle trajectory to the sense wire was first amplified and discriminated. Through 3 m twisted pair cable the ECL line driver in discriminator circuit sent the digitized signal (ECL level) to a ECL-NIM level shifter (NIM module). The level shifted signal (NIM level) was sent to TDC (CAMAC module) as STOP signal through a coaxial cable. The TDC device converts a time interval into a digital number. The two timing signals are START and STOP signals. The pedestal of the using TDC measured 30 nsec.

The experiment was controlled by a data taking program on a PC-9800, which read the CAMAC devices (TDC) and wrote the events on a hard disk. Furthermore, when high voltage tripped, the time was also recorded.

Result

The amplified signal from the sense wire is sent to a discriminator with an adjustable threshold. Particle detection efficiency as a function of applied threshold voltage is shown in fig. 6. The threshold setting was optimized to reject noise, yet maintain high efficiency and stability. A loss of efficiency from increasing the discriminator threshold can be offset to some extent by increasing the high voltage. Particle detection efficiency as a function of the applied voltage is shown in fig. 7. High voltage have been operated at 1.95 KV. (The counting efficiency shown in figures dose not take geometrical efficiency into account.)

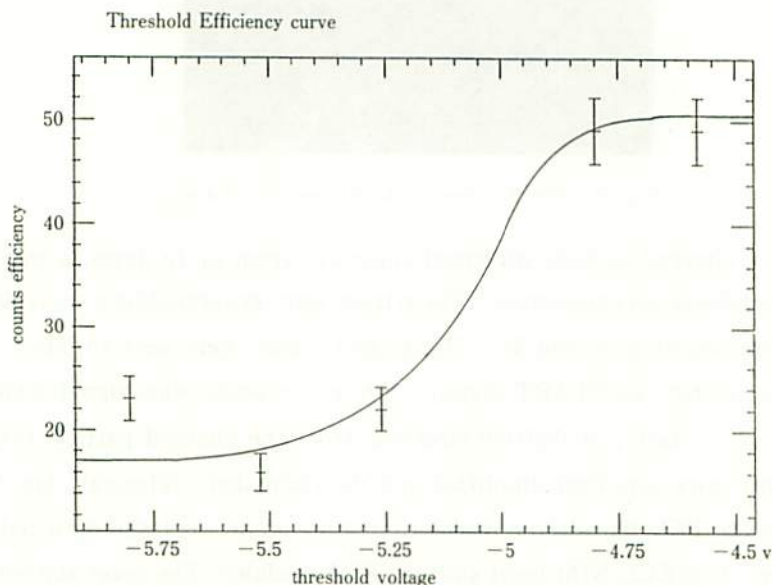

Fig. 6 Particle detection efficiency as a function of discriminator threshold voltage.

The different time between START and STOP signales did not give the actual drift time. There was a delay time. The delay time was determined by computation to make cross tracks with the sense wire plane straight lines. The resolution of one wire in a series of wires was determined by fitting a track through all the wires but one and then measuring the deviation of the measured

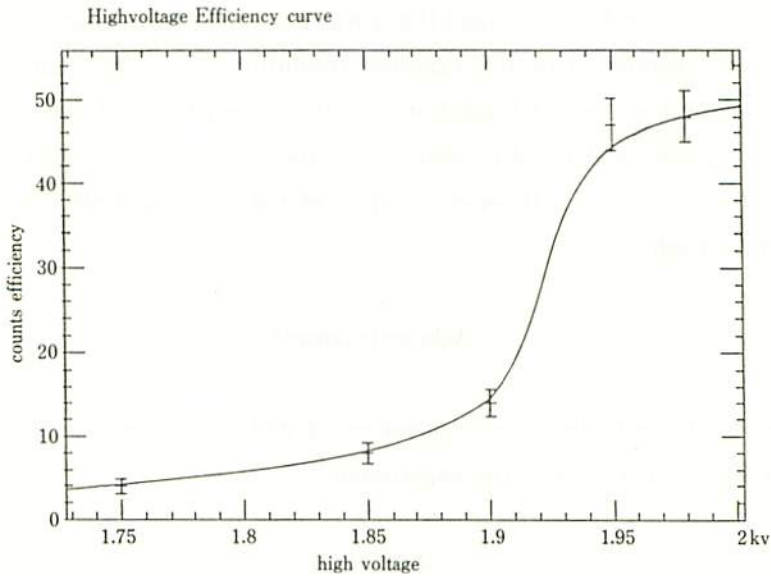

Fig. 7 Particle detection efficiency as a function of high voltage.

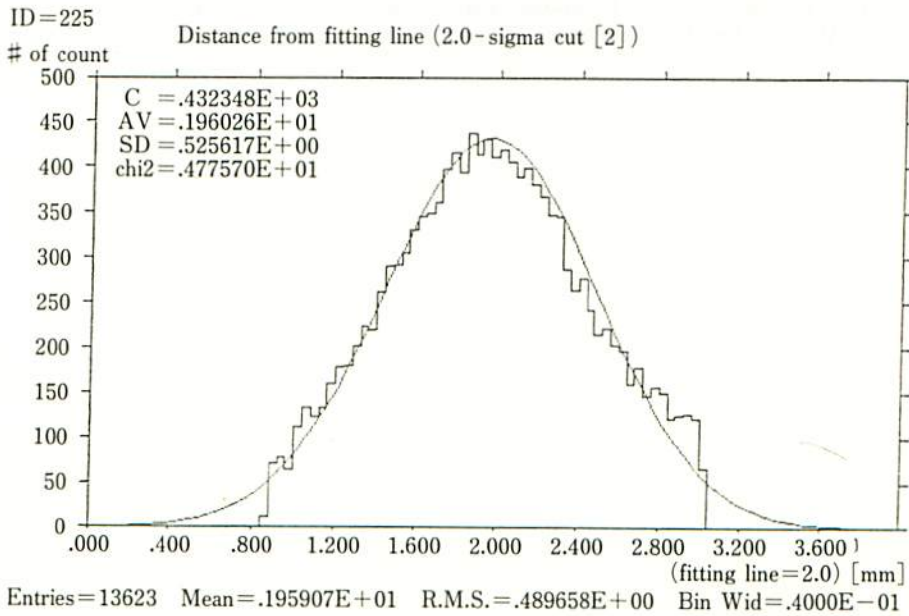

Fig. 8 Deviation distribution of the measured position from the fitted value.

position from fitted value. From the distribution for all the wires, which is shown in fig. 8, we have obtained the spatial resolution of the chamber $\sigma \sim 500 \mu\text{m}$.

It is comparable with the expected resolution for such a small chamber where the limit of spatial resolution are determined by the time resolution of the TDC ($20 \mu\text{m}$) and the diffusion of electrons during their migration towards the sense wire ($300 \mu\text{m}$). However in spite of the expected field distortion, the spatial resolution is good.

Acknowledgment

We would like to thank our colleagues of AMY Collaboration for providing some of the devices used in the experiment.

References

- 1) F. Sauli, CERN 77-09 (1977).
- 2) AMY collaboration, TRISTAN proposal for Study of $e^+ e^-$ Interactions with a High Luminosity High Resolution Lepton Detector, KEK (1984).
- 3) M. Majima, Ph. M. dissertation, Niigata Univ., unpublished (1986).