

**BIOFILM FORMATION ON METAL SURFACES**

**IWONA B. BEECH**

presented in partial fulfilment  
for the degree of Doctor of Philosophy  
to the Council for National Academic Awards

June 1990

City of London Polytechnic  
Old Castle Street, London, E1 7NT

**PAGE  
NUMBERING  
AS  
ORIGINAL**

**BEST COPY**

**AVAILABLE**

Variable print quality

## **DEDICATION**

**To my parents and my grandmother.**

**Moim rodzicom i babumi.**

## DECLARATION

I, Iwona B. Beech, declare that whilst registered as a full-time candidate for the degree of Doctor of Philosophy, at the City of London Polytechnic, I was not registered for any other award of the CNAAB or of a University. The work undertaken during this period was carried out by myself at the City of London Polytechnic, with guidance from Mrs. C.C. Gaylarde at the Polytechnic and Dr. R.G.J. Edyvean of the University of Leeds.

Several advanced studies were undertaken in conjunction with my research programme in partial fulfilment of the degree of Doctor of Philosophy. These included a course on Biofilms in Municipal and Industrial Water Systems at Montana State University, Bozeman, Montana, USA. I also presented a research seminar to the academic staff at the City of London Polytechnic and was involved in tutorials and practical demonstrations to undergraduate students.

I attended two meetings of the Society for General Microbiology, the 7<sup>th</sup> International Biodeterioration Symposium (Cambridge 1987) and the 9<sup>th</sup> International Symposium on Lectins (Cambridge 1987). Several papers have been published as a result of this investigation.

Iwona B. Beech, June 1990

## ACKNOWLEDGEMENTS

I wish to thank Christine Gaylarde and Robert Edyvean for all their helpful advice and support during this investigation and preparation of this thesis.

I also gratefully acknowledge the financial support from the Society for General Microbiology which allowed me to visit several research laboratories in the USA, and the Agricultural and Food Research Council for the Wain Fellowship Award to carry out research in the laboratory of Professor G.G. Geesey at California State University, Long Beach. I am grateful to Professor Geesey for allowing me the use of his equipment and facilities. I thank Jim Smith, a member of Professor Geesey's group, for all his help, in particular for elucidating the mysteries of Gas Chromatography.

My thanks are also extended to all the staff of the City of London Polytechnic who have provided help; special thanks to Patrick Foster for his assistance in the preparation of the photographs for this thesis, Steve Fewings for his advice on instrumentation, Phil Cooke of the Department of Metallurgy for his help with electron microscopy, Martin Turner from South Bank Polytechnic for his assistance with scanning electron microscopy and Robert Matthew's guidance in the use of computer facilities.

I would like to acknowledge the support and encouragement of Alan Williams, the Warden of Toynbee Hall during the period of my study.

Finally I would like to thank my friend Trevor for his help in preparation of this thesis.

## ABSTRACT

The development of biofilms on mild and stainless steel surfaces in pure and mixed batch cultures of the bacterial species *Pseudomonas fluorescens* and *Desulfovibrio desulfuricans* and the role of these biofilms in corrosion of steel has been investigated. Early events leading to the formation of biofilms have been elucidated by studying the attachment of bacterial cells to steel using epifluorescence microscopy. To identify the nature of the bacterial surface components involved in the initial adhesion to mild steel, lectins, their sugar inhibitors and saccharolytic and proteolytic enzymes have been employed. Polyclonal antibodies have been raised against bacterial lipopolysaccharides (LPS) and their influence on bacterial adhesion assessed. LPS have been analysed chemically by gas-chromatography (GC-FID) and gas chromatography-mass spectrometry (GC-MS) to determine their carbohydrate composition and fatty acid content. On the basis of the results obtained the involvement of glucose and N-acetylglucosamine, present in O-antigenic fractions of LPS, in the initial attachment of the two bacterial species to mild steel is suggested. Both types of carbohydrates are likely to be involved in early attachment of *Pseudomonas* to mild steel, whereas only a polymeric form of N-acetylglucosamine seems to participate in adhesion of *Desulfovibrio*.

The subsequent biofilm development on steel surfaces and their accompanying corrosion has been monitored by scanning electron microscopy (SEM). SEM studies reveal very different patterns of bacterial biofilms on mild and stainless steel and show varied degrees of corrosion occurring on these surfaces. Thin and patchy *Pseudomonas* biofilms are accompanied by little corrosion whilst thick, more continuous, *Desulfovibrio* biofilms are associated with higher levels of corrosion. Energy dispersive X-ray analysis (EDAX) of corrosion products present on steel surfaces indicates ferrous sulphides as the major components in *Desulfovibrio* biofilms. The corrosion of steel in bacterial cultures has also been investigated by kinetic polarisation measurements. The results obtained from cathodic and anodic polarisation curves, combined with SEM and EDAX analyses confirm the SEM observation. Stainless steel is not subjected to any great degree of fouling or corrosion under the chosen experimental conditions.

The EPS associated with biofilms and released into the liquid phase of the culture media (free EPS) has been characterised. Proteins and carbohydrates in these polymers are detected colorimetrically and by SDS-gel electrophoresis. Uronic acids, found in biofilm-bound EPS, are not detected in free EPS. The GC-MS and GC-FID analyses have aided in establishing types and quantities of neutral carbohydrates present in bacterial exopolymers and show that the neutral sugar composition of free and surface-associated EPS is not identical for a given bacterial culture. The biofilm-bound EPS are believed not to play a major role in corrosion of mild steel but to provide additional mechanisms in its facilitation. No correlation between levels of free EPS and corrosion of steel is found.

## TABLE OF CONTENTS

CHAPTER	CONTENTS	PAGE
1.	<b>Introduction.</b>	1
1.1	Attachment of bacterial cells to surfaces.	2
1.1.1	Surface properties of bacteria involved in attachment.	2
1.1.2	Role of bacterial exopolymers in attachment.	6
1.1.3	Properties of substrata.	8
1.1.4	Effect of solid surfaces on the activity of attached cells.	10
1.2	Biofilm formation and microbial fouling.	11
1.3	Corrosion of metals in aqueous environments.	15
1.3.1	Methods of corrosion assessment.	17
1.4	Microbially induced corrosion of metals.	18
1.4.1	Measurement of microbial corrosion by potentiodynamic polarisation technique.	19
1.5	Role of biofilms in corrosion of metals.	23
1.6	The role of bacterial exopolymers in corrosion of metals.	24
1.7	Involvement of SRB in corrosion of metals.	25
1.8	The involvement of bacteria of the genus <i>Pseudomonas</i> in corrosion.	28
1.9	Aims of the investigation.	29



<b>CHAPTER</b>	<b>CONTENTS</b>	<b>PAGE</b>
<b>2</b>	<b>Materials and methods</b>	<b>30</b>
2.1	Organisms.	31
2.2	Transmission electron microscopy (TEM).	31
2.3	Production and purification of antibodies against bacterial lipopolysaccharides (LPS).	32
2.3.1	Antibody production.	32
2.3.2	Purification of immunoglobulin (Ig).	32
2.3.3	Testing of purified Ig by cell agglutination.	32
2.4	Cell adhesion studies.	33
2.4.1	Metal surfaces used in adhesion experiment.	33
2.4.2	Preparation of cells for adhesion experiments.	33
2.4.3	Lectin treatment.	34
2.4.4	Sugar-lectin treatment.	34
2.4.5	Enzyme treatment.	34
2.4.6	Treatment with antibodies raised against bacterial lipopolysaccharides (A-LPS).	34
2.4.7	Measurement of adhesion.	35
2.5	Biofilm production and microbiological analysis.	35
2.5.1	Metal surfaces used for growth of biofilms.	35
2.5.2	Biofilm growth.	36
2.5.3	Recovery of biofilms for chemical analysis.	37
2.5.4	Treatment of seven day old biofilm samples prior to chemical analysis.	37
2.5.5	Scanning electron microscopy (SEM) of biofilms.	37

<b>CHAPTER</b>	<b>CONTENTS</b>	<b>PAGE</b>
2.6	Chemical analysis of free bacterial extracellular polymeric substances (EPS) and biofilms.	38
2.6.1	Isolation of free EPS.	38
2.6.2	Colorimetric assays for determination of carbohydrates. in EPS and biofilm samples.	39
2.6.3	Gas chromatographic analyses of carbohydrates present in EPS and biofilms.	40
2.6.3.1	Reduction of sugars.	40
2.6.3.2	Hydrolysis of sugars.	41
2.6.3.3	Derivatisation of sugars.	41
2.6.3.4	Preparation of sugar standards for gas chromatography.	41
2.6.3.5	Gas chromatography.	42
2.6.3.6	Gas chromatography-mass spectrometry (GC-MS).	42
2.6.3.7	Quantification of neutral carbohydrates detected in EPS samples by GC-FID.	43
2.6.4	Protein determination in free EPS and biofilm samples.	43
2.6.4.1	Colorimetric assay	43
2.6.4.2	Gel electrophoresis of proteins in free EPS and biofilm samples.	44
2.7	Analysis of bacterial lipopolysaccharides (LPS).	44
2.7.1	Extraction of LPS.	44
2.7.2	Hydrolysis of LPS.	46
2.7.3	Extraction and methylation of fatty acids from lipid A fraction of LPS.	46
2.7.4	Identification of LPS-FA by GC-MS.	47
2.7.5	Determination of carbohydrates in LPS samples.	47

<b>CHAPTER</b>	<b>CONTENTS</b>	<b>PAGE</b>
2.7.6	Gel electrophoresis of LPS.	48
2.7.6.1	Detection of carbohydrates in LPS gels.	48
2.8	Corrosion studies.	48
2.8.1	SEM observations of corrosion on MS and SS surfaces.	49
2.8.2	Energy dispersive X-ray analysis (EDAX) of corrosion products present on MS and SS electrodes.	49
2.8.3	Polarisation measurements.	50
2.8.3.1	Sample preparation for polarisation studies.	50
2.8.3.2	Potentiostatic measurements.	50
<b>3</b>	<b>Results.</b>	<b>54</b>
3.1	Morphology and growth of <i>P. fluorescens</i> and <i>D. desulfuricans</i> .	55
3.1.1	Viable cell count.	58
3.2	The attachment of bacteria to steel surfaces.	59
3.2.1	The attachment of bacteria to MS and SS surfaces in medium C and in water.	59
3.2.2	The influence of lectins and their sugar inhibitors on bacterial adhesion.	60
3.2.3	The effect of enzymes on bacterial attachment to MS surfaces.	62
3.2.4	Slide agglutination tests for antibody specificity.	64
3.2.5	The effect of antibodies raised against bacterial LPS on attachment of cells to MS surfaces.	64
3.3	Analysis of LPS extracted from bacteria.	67
3.3.1	SDS gel electrophoresis of LPS samples.	67
3.3.2	Analysis of fatty acids (FA) extracted from lipid A of bacteria LPS.	69

<b>CHAPTER</b>	<b>CONTENTS</b>	<b>PAGE</b>
3.3.3	Analysis of carbohydrates present in bacterial LPS.	69
3.4	Characteristics of biofilms formed on steel coupons.	74
3.4.1	Chemical analyses of biofilms grown on steel coupons.	78
3.4.1.1	Detection of carbohydrates in SDS-gels.	79
3.4.1.2	Colorimetric estimation of carbohydrates present in biofilms.	80
3.4.2	Chromatographic analyses of carbohydrates present in biofilms.	81
3.4.3	Determination of proteins in biofilms removed from MS and SS coupons.	83
3.4.3.1	Colorimetric estimation of proteins in biofilms removed from MS and SS coupons.	83
3.4.3.2	SDS-gel electrophoresis of proteins in biofilm samples.	85
3.4.4	EDAX analysis of biofilms formed on MS and SS surfaces.	86
3.4.4.1	SEM observation of steel surfaces prior to EDAX analysis.	86
3.4.4.2	EDAX analysis of biofilms.	90
3.5	Analysis of bacterial EPS released into culture medium.	95
3.5.1	Detection of carbohydrates present in free EPS by SDS-PAGE.	96
3.5.2	Colorimetric estimation of carbohydrates present in free EPS.	96
3.5.3	Chromatographic analysis of carbohydrate present in bacterial EPS.	100
3.5.4	Analysis of carbohydrates present in precipitate recovered from sterile medium C.	103

<b>CHAPTER</b>	<b>CONTENTS</b>	<b>PAGE</b>
3.5.5	Analysis of proteins present in free EPS samples.	105
3.5.5.1	Determination of protein in free EPS samples.	105
3.5.5.2	SDS gel electrophoresis of proteins present in free EPS samples.	107
3.6	SEM examination of SS and MS surfaces used as electrodes in potentiostatic measurements.	108
3.6.1	Examination of SS surfaces.	108
3.6.2	Examination of MS surfaces.	112
3.7	Kinetic polarisation studies.	120
3.7.1	Polarisation curves for MS electrodes.	120
3.7.1.1	Cathodic curves.	120
3.7.1.2	Anodic curves.	121
3.7.1.3	Polarisation curves after biofilm removal.	121
3.7.2	Polarisation curves for SS electrodes.	127
3.7.2.1	Cathodic curves.	127
3.7.2.2	Anodic curves.	127
3.7.3	Measurements of pH values of electrode-containing media.	131
<b>4</b>	<b>Discussion, conclusions and recommendations.</b>	<b>132</b>
4.1	Initial attachment of bacteria to steel surfaces.	133
4.2	Biofilm formation on steel surfaces.	138
4.3	Corrosion of steel in bacterial cultures.	144
4.4	Conclusions.	149
4.5	Recommendations for future work.	152
	<b>Bibliography</b>	<b>153</b>
	<b>Appendix</b>	<b>167</b>

## **CHAPTER ONE**

### **INTRODUCTION**

## **1.1 ATTACHMENT OF BACTERIAL CELLS TO SURFACES**

The attachment of bacterial cells to a surface leads to colonisation of the surface and thus is an early stage in the development of a biofilm.

Bacteria adsorb to surfaces by a variety of mechanisms. The analysis of these mechanisms involves a study of the surface properties of the bacterial cells and of the properties of the substrate concerned.

### **1.1.1 SURFACE PROPERTIES OF BACTERIA INVOLVED IN ATTACHMENT**

As revealed by electrophoretic measurements, bacteria possess a net negative surface charge (Richmond and Fischer, 1973; Pedersen, 1981). In Gram-positive bacteria teichoic acid and teichuronic acid in the cell wall and acidic polypeptides and polysaccharides contribute to the negative charge. In Gram-negative bacteria acidic lipopolysaccharides (LPS) and proteins of the outer membrane, in addition to extracellular polysaccharides, are sources of negative charge. Lipopolysaccharides are amphipathic molecules composed of a hydrophobic part, the lipid A, and a hydrophilic part consisting of an oligosaccharide core which is usually substituted by the O-antigen (O-side chain). R forms (rough forms) of the bacteria synthesise incomplete LPS which lack the O-specific side chains and eventually also part of the core. The S forms (smooth forms) synthesise complete LPS. Figure 1 gives a schematic representation of the structure of an LPS molecule.

Many bacterial species are differentiated into subtypes (serotypes) on the basis of their reactions with specific antisera directed against cell surface molecules. In the case, for example, of the genus *Salmonella*, each bacterial serotype synthesises a unique LPS, characterised by a specific composition and structure of the O-side chain and by an individual O-antigenicity.

**Figure 1**  
**Diagrammatic representation across a Gram Negative Bacterial**  
**Outer Membrane and of a Typical Lipopolysaccharide Molecule**

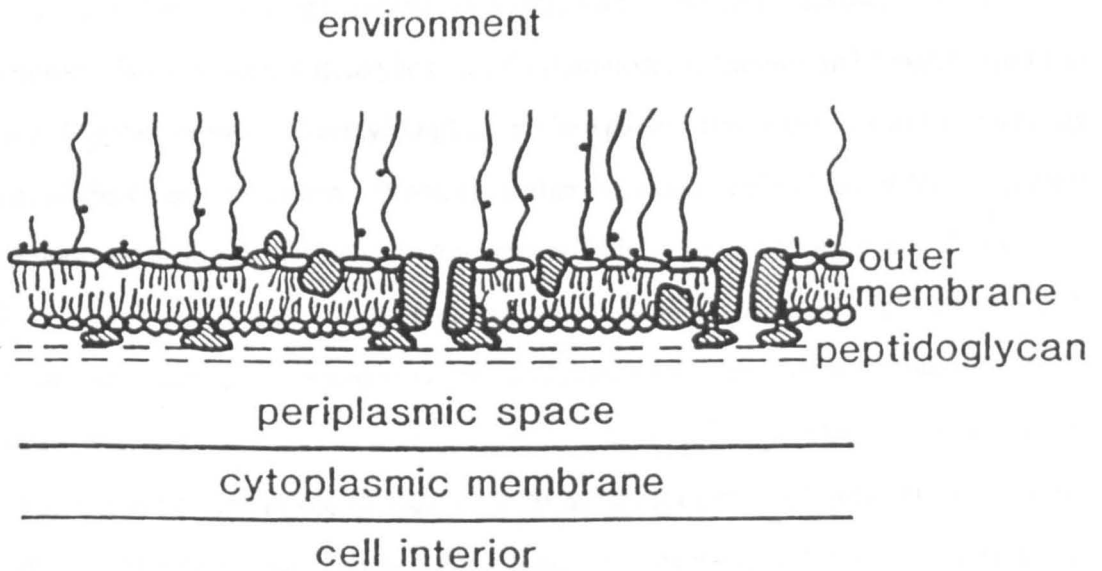

- KEY
- metal cation
  - ◐ phospholipid
  - ◑ lipopolysaccharide
  - ◒ protein
  - ◓ lipoprotein

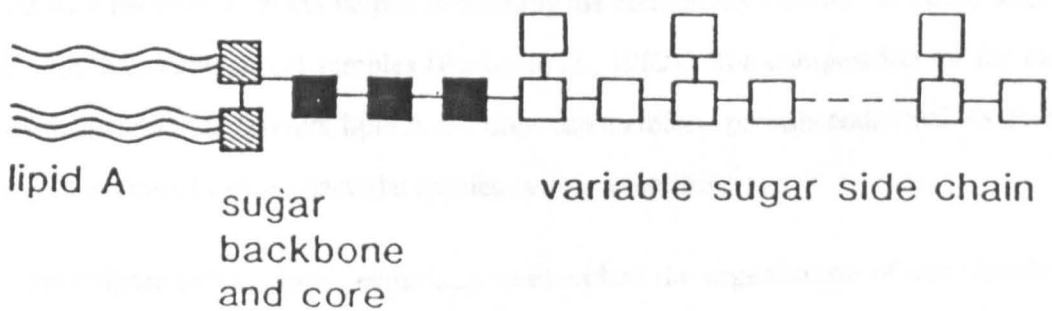



The anti-LPS antibodies formed during immunisation are directed against the immunodeterminant structures present in the O-side chains of LPS (Luderitz et al., 1966). These side chains are composed of repeating units of identical oligosaccharides (Robbins and Uchida, 1962). A large diversity of sugars such as common hexoses (D-glucose, D-galactose, D-mannose), 6-deoxyhexoses (L-rhamnose, L-fucose) and hexosamines (N-acetyl-D-galactosamine, N-acetyl-D-glucosamine) participates in the structure of repeating units of the O-specific chains. Pentoses (arabinose, ribose, xylose) occur less frequently and their identification in LPS extracts may be indicative of contamination (Wilkinson, 1977). LPS containing acidic constituents such as uronic acids (glucuronic acid, galacturonic acid, galactosamine uronic acid) have also been found amongst bacterial species such as *Shigella* (Galanos et al., 1977). The LPS is heterogeneous regarding the length and the nature of the O-chains due to different degrees of polymerisation of the repeating oligosaccharide units. The length of the O-specific side chains varies considerably from one repeating unit to more than thirty repeating units thus influencing hydrophilicity of the LPS molecule.

Lipid A of bacterial LPS typically contains D-glucosamine, fatty acids, phosphate and ethanolamine in varying proportions. The fatty acid pattern of lipid A seems to be a characteristic feature of an individual LPS, being independent of culture conditions and external supply of fatty acids. The examination of the patterns of hydroxy fatty acids in the lipid A of bacterial LPS has helped in defining the community structure of Gram-negative bacteria in environmental samples (Parker et al., 1982). The composition of the major fatty acids found in different lipid A fractions can therefore provide additional insight into the distribution of various bacterial species within a biofilm.

To investigate cell surfaces, especially to elucidate the organisation of cell membrane carbohydrate-containing antigens such as LPS, lectins are often used as probes. The

lectins represent a wide class of proteins or glycoproteins which can reversibly react with terminal non-reducing and internal sugar residues of both macro and low molecular weight molecules. A white clover lectin trifoliin A has been employed in studying the uniformity of exopolysaccharide production and in characterising LPS synthesis at the cell surface of *Rhizobium* species (Hrabak et al., 1982; Sherwood et al., 1984). Concanavalin A (ConA) has been used to purify polysaccharides from *Mycobacterium tuberculosis* (Daniel and Todd, 1975). ConA, obtained originally from the seeds of jack beans, precipitates various polysaccharides and reacts with a variety of carbohydrates. It binds specifically to the sugars glucose, sucrose, mannose, N-acetylglucosamine and methylmannoside. The lectin wheat-germ agglutinin (WGA) has been used in studying the distribution of specific carbohydrate-binding receptors on the surface of eucaryotic cells (Gros et al., 1982). WGA has two independent binding sites for N-acetylglucosamine and its B(1,4)linked oligomers. The free sugar is a poor inhibitor of WGA-binding to glycoconjugates, but the disaccharide form, chitobiose, is a potent inhibitor (Gallagher et al., 1983). Both ConA and WGA are proteins devoid of sugar residues.

Bacteria exhibit a variation in overall surface free energy of the cells, with some bacteria possessing relatively hydrophobic and others relatively hydrophilic surfaces (Magnusson et al., 1977; Dahlback et al., 1981). Methods developed to probe the relative hydrophobicity or hydrophilicity of bacterial cells involve partition between hydrophilic and hydrophobic phases in two-phase systems (Rosenberg et al., 1982), hydrophobic interaction chromatography by octyl agarose gel separation (Dahlback et al., 1981), adherence to polystyrene (Rosenberg, 1981), or contact angle measurements (van Loosdrecht et al., 1987). Cell surface hydrophobicity is considered an important factor in the non specific adhesion of bacteria to interfaces (Fattom and Shilo, 1984) and both electric charge and distribution of hydrophobic sites on bacterial surfaces may contribute to adhesion. The physiochemical forces participating in adhesion of a bacterium to a solid

surface include long-range forces, e.g., electrostatic interactions and van der Waals forces, and short-range interactions, e.g., dipole interaction, chemical (electrostatic, covalent, hydrogen) bonding and hydrophobic interactions. In natural ecosystems bacterial adhesion to inert surfaces such as plastic, metal, glass, or minerals is generally regarded as non-specific, in contrast to adhesion to biological surfaces where specific receptors such as lectins play an important role (Dazzo, 1980; Ofek, 1977).

### 1.1.2 ROLE OF BACTERIAL EXOPOLYMERS IN ATTACHMENT

Following attraction to a surface bacteria become firmly attached to it as a result of the synthesis of extracellular polymers (ZoBell, 1943; Marshall et al., 1971 ). Polymer bridging seems to be a universal way of irreversible attachment of bacteria to a wide variety of surfaces. The presence of the polymer at the surface can be visualised in electron microscope preparations using polyanion-specific stains such as ruthenium red and alcian blue. However, the dehydration required for electron microscopy can easily destroy fine polysaccharide matrices due to their high water content, generally greater than 99% by weight (Sutherland, 1977). Modern techniques of exopolymer stabilisation using lectins (Bridsell et al., 1975) or specific antibodies (Mackie et al., 1979) preserve the fine fibrillar structure in its true dimension. Chemical analysis of the crude bacterial exopolymer isolated from cells of a freshwater sediment bacterium exhibiting *Pseudomonas*-like characteristics has revealed the presence of protein, polysaccharide and nucleic acid (Platt et al., 1985). The composition and biosynthesis of Gram-negative bacterial extracellular polysaccharides has been recently reviewed by Sutherland (1985). The extracellular polysaccharides are generally but not always acidic. The acidic component is most often a uronic acid. Some Gram negative bacteria produce polysaccharides composed of only neutral sugars and uronic acids, whilst others tend to produce a much wider range of components such as amino sugars, sugars resembling teichoic acids, ketal-linked

pyruvylated sugars, or phosphorylated monosaccharides (Kenne and Lindberg, 1983; Lion et al., 1988). Uronic acids are almost unique to the polysaccharides found outside the cytoplasmic membrane of the cells. Only occasionally are they found in some bacterial lipopolysaccharides (Ray et al., 1986). Those bacterial polysaccharides which have been analysed have been found to contain various types of uronic acids such as D-glucuronic acid, D-galacturonic acid, D-mannuronic acid and L-gulonic acid (Dudman, 1977). Glucuronic acid was found to contribute 32% of the total weight of exopolysaccharide produced by *P. aeruginosa* (Stojkovski, 1986). Estimation of uronic acid content can provide a quantitative measure of exopolymer formation and catabolism (Fazio et al., 1982).

Studies of the effect of bacterial growth phase on extracellular polysaccharide production have brought varying results. For some bacterial cultures the maximal production of extracellular polysaccharides occurs in the stationary phase (Uhlinger and White, 1983) and for others in the exponential phase (Mian et al., 1978). In some cases the amount of polysaccharide produced is abundant in all phases of growth (Boyle and Read, 1983; Robinson and al., 1984). A marine *Pseudomonas* species has been observed to produce two types of extracellular polysaccharides depending on the growth stage (Christensen et al., 1985). Culture conditions such as medium composition and concentration, temperature and pH may also influence the production of extracellular polysaccharides (Corpe, 1970; Fletcher, 1977; Jones, 1970). Polysaccharide production has been shown to be enhanced in mixed *Pseudomonas* cultures compared with levels produced in pure cultures (Angell and Chamberlain, 1991).

Often after adhesion and polymer production bacteria may be seen within the matrix as microcolonies (Costerton et al., 1981). The ability of bacteria to produce exopolymer is not necessarily synonymous with adhesiveness, however. Some bacteria attach to surfaces

despite a lack of polymer production (Brown et al., 1977; Wardell et al., 1980). The reverse has also been reported. Little adhesion of bacterial cells in spite of abundant exopolymer production was noted by Pringle and Fletcher (1983). Bacterial surface appendages such as flagella, pili and fimbriae may also be implicated in bacterial adhesion (Pearce and Buchanan, 1980; Isaacson, 1985), although a study of the attachment of *P. aeruginosa* to stainless steel showed that motility of the cells enhanced attachment but flagella as structural elements were not important in adherence (Stanley, 1983). The loss or modification of the adhesive properties of many bacteria under *in vitro* conditions may implicate chromosomal and/or plasmid control of the adhesion process (Costerton et al., 1981; Rosenberg et al., 1982).

### 1.1.3 PROPERTIES OF SUBSTRATA

The forces involved in adhesion of cells to substrata may include any of the interactions possible in aqueous physical systems, such as sedimentation, chemotaxis, Brownian motion, or fluid dynamic forces. These mechanisms provide the means for transporting bacteria from the bulk aqueous phase to the vicinity of the surface. Most solid surfaces in natural habitats possess a net negative charge as do most bacteria. Thus, electrostatic repulsion between the surfaces of like charge will tend to prevent close approach between them. If repulsion is strong enough, the two surfaces will not come close enough for adhesion to occur. The classical work on colloid stability or DLVO (Derjaguin-Landau-Verveij-Overbeek) theory considers the balance between the London-van der Waals attractive forces and the electrostatic repulsive interaction between two surfaces. By measuring the surface charge in aqueous systems and by estimating the London and polar components of the surface energies of solid surfaces it is possible to examine the theoretical basis of the adhesion process (Rutter and Vincent, 1980). A number of workers have tried to evaluate the role of long- or short-range forces in bacterial adhesion. The influence of

short-range forces has been investigated by determining the relationship between the attachment and the surface energies or related parameters of the substrata. A measure of surface energy often used when investigating surface properties is the critical surface tension, being the highest surface tension of a liquid which will still completely wet a surface (i.e. a contact angle of zero) without reacting with the material or being absorbed by it. Metals typically have high energy and hydrophilic surfaces, while plastics usually have low energy hydrophobic surfaces. It has been shown that surface properties such as hydrophilicity (high surface tension), hydrophobicity (low surface tension) or the surface energy of a material can influence bacterial attachment. In some instances adhesion is more extensive to hydrophilic substrata (Baier, 1980) while other cells attach preferentially to hydrophobic substrates (Fletcher and Loeb, 1979; Absolom et al., 1983). The interfacial free energy of substrata may be determined by a method such as bubble contact angle measurement (Fletcher and Marshall, 1982). It has been reported that factors such as change in electrolyte concentration, in pH value or in surface charge of particular bacteria, by influencing long-range electrostatic interactions can affect adhesion of bacteria to solid surfaces such as glass (Marshall et al., 1971a) and stainless steel (Stanley, 1983). However, Abbot et al. (1983) found no relationship between attachment of bacteria to glass and electrolyte concentration or bacterial surface charge. McEldowney and Fletcher (1986) reported that adhesion of various bacterial species to different types of polystyrene varied with species, substratum, and electrolyte type, concentration and pH. No apparent correlation between adhesion and electrostatic and hydrophobic interactions has been found, indicating that adhesion can not be attributed to any one type of interaction.

The influence of surface conditioning films on attachment has been demonstrated by various workers. Gordon (1987) reported changes in attachment of *Vibrio* spp. to stainless steel induced by the presence of alginate on the surface. The effect of pretreatment of polystyrene surfaces with various proteins on changes in adhesion of a

marine *Pseudomonas* to these surfaces has been shown by Fletcher (1976). The effect of surface roughness and toxicity as well as the impact of environmental variables such as inorganic ions, oxygen concentration and temperature on adhesion has been reviewed by Duddridge and Pritchard (1983).

#### 1.1.4 EFFECT OF SOLID SURFACES ON THE ACTIVITY OF ATTACHED CELLS

The influence of solid surfaces on bacterial activity has been demonstrated by measuring a variety of parameters, including changes in number of suspended and attached cells (Harwood and Pirt, 1972; Hattori, 1972), change in cell size (Kjelleberg et al., 1982), respiration rate in terms of carbon dioxide production (Bright and Fletcher, 1983b), oxygen uptake, electron transport activity, or substrate uptake (Bright and Fletcher, 1983a). A large amount of data illustrates that solid surfaces can affect bacterial activity, causing enhancement or inhibition of attachment depending on experimental conditions and variation in substratum composition (Fletcher and Marshall, 1982). There is evidence that surfaces added to bacterial culture in some cases can cause an increase in total activity of attached and unattached cells (Fletcher, 1986). The attachment of bacterial cells to a surface has been found to modify certain physiological properties of the bacteria such as shape and size, spore formation and flagellation, indicating that some sort of surface recognition mechanism must be present (Ou and Alexander, 1974; Kjelleberg et al., 1982). Most recently the influence of interfaces on bacterial adhesion in natural and artificial systems has been critically reviewed by van Loosdrecht et al. (1990). The authors conclude that, based on data reported in the literature and by the use of thermodynamic and kinetic considerations, neither experimental nor theoretical evidence exists for a direct influence of interfaces on microbial activity. They believe that observed differences between adhered and free cells can all be attributed to an indirect mechanism causing modification of the surroundings of the cell but not of the cell itself.

## **1.2 BIOFILM FORMATION AND MICROBIAL FOULING**

The formation of microbial communities on submerged surfaces in the aquatic environment creates an assemblage termed a biofilm. The attached cells grow, reproduce and produce extracellular polymeric substances that extend from the cell forming an organic matrix (Characklis and Cooksey, 1983). This matrix consists of macromolecules such as polysaccharides, simple sugars (Fletcher and Floodgate, 1973), glycoproteins, proteins and nucleic acids (Fazio et.al., 1982). In the presence of metals this polysaccharide-containing matrix often takes the form of a gel (Brown and Lester, 1982). Biopolymers contribute to the biofilm providing adhesive forces within it, adsorbing nutrients, protecting immobilised cells from rapid environmental changes (such as the addition of biocides), absorbing heavy metals, particulate materials and other detritus from the environment and enhancing intercellular transfer of genetic material (Characklis and Cooksey, 1983; Lion et al., 1988). The natural life of the biofilm is cyclical. The mass of the biofilm increases by cellular proliferation, polymer production and trapping of cells within the matrix; it decreases by cell death, detachment at the flowing surface and grazing by benthic macroorganisms (Costerton et al., 1985). Figure 2a gives a schematic representation of biofilm dynamics.

Biofilm development is considered to be a result of physical, chemical and biological processes: transport of organic molecules and microbial cells to the surface, adsorption of organic molecules to the surface resulting in a "conditioned surface", adhesion of microbial cells to the conditioned surface, metabolism by these attached cells and detachment of portions of the biofilm (Characklis and Cooksey, 1983). Figure 2b illustrates these processes.



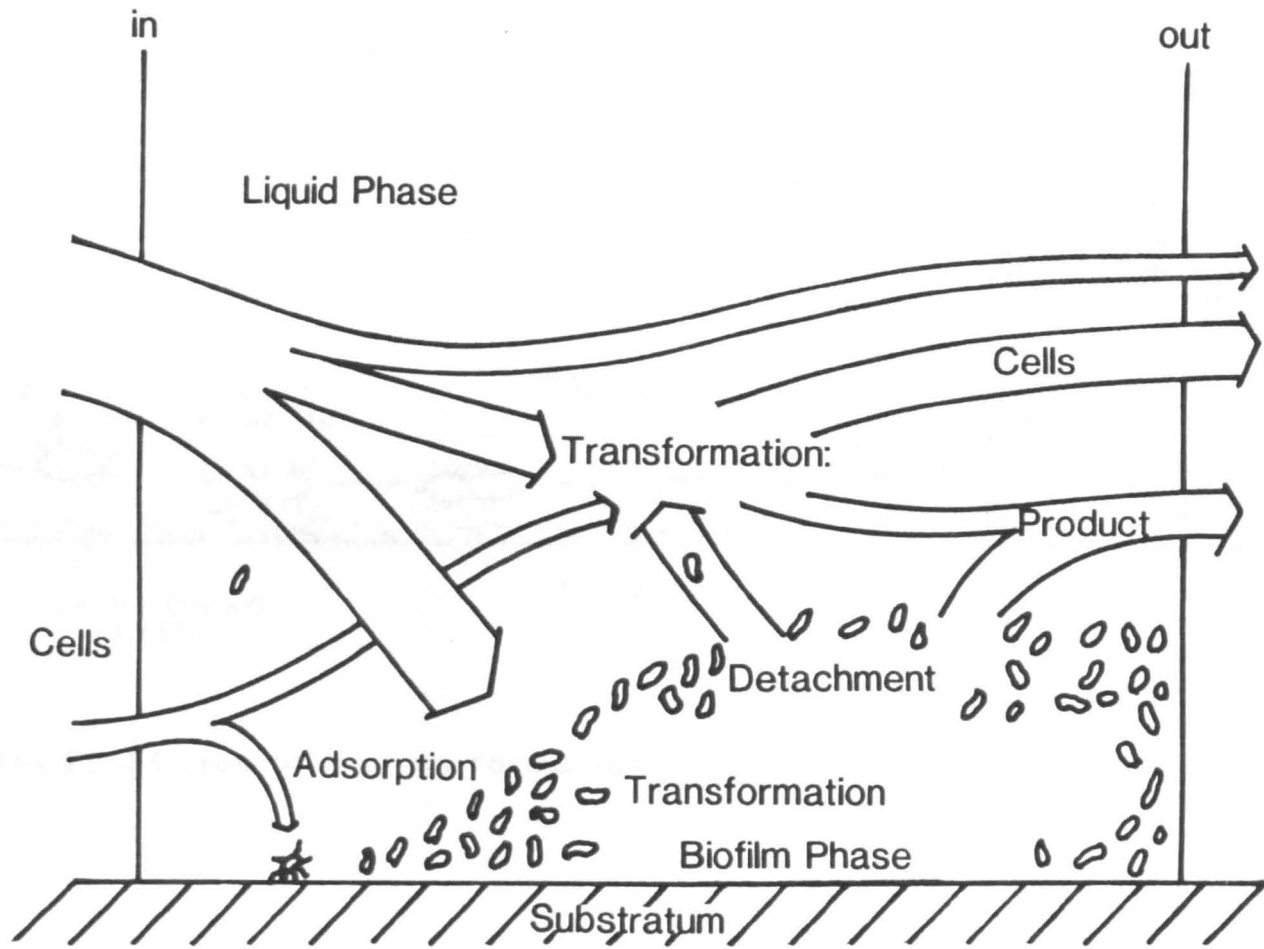
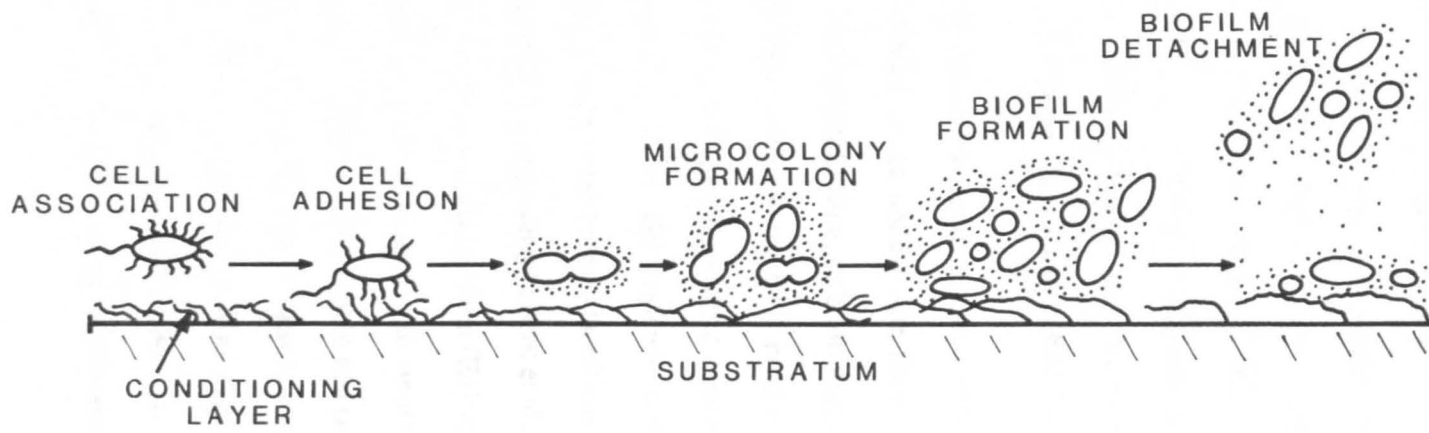

Fig.2a Biofilm dynamics in aquatic environment



**Fig.2b Stages of biofilm formation**

Biofilms can be beneficial to natural environments by removing organic and inorganic contaminants from water and wastewater (Hollo et al., 1979), but they may pose problems to man through their role in fouling and in the clinical situation. Biofilms very similar to those seen in natural ecosystems are formed on plastic and metal prostheses implanted into hospital patients. The mode of growth of such biofilms protects pathogenic organisms, limiting their vulnerability to host defence mechanisms (phagocytic and immunological) and to challenge by specific antibiotics, thus placing limitations on the use and development of prostheses in medicine (Costerton and Marrie, 1983; Costerton et al., 1985).

Biofilm formation in the natural environment and in industrial situations is often known as fouling. Fouling is defined as the undesirable formation of inorganic and/or organic deposits on a surface. Biological fouling, or biofouling, starts with the development of a biofilm consisting of microorganisms and their products. Such microbial fouling often accelerates other types of fouling by providing a nutrient source for organisms or an adsorbing layer for inorganic debris. The presence of the biofilm often results in energy and material losses. Biofilm formation retards the efficient transfer of heat through metallic surfaces exposed to the aquatic environment (Berk et al., 1981; Afring and Taylor, 1979) and increases frictional resistance of the surface (Edyvean, 1987). The consequences of microbial fouling often have serious economic implications in the chemical process industry, in industrial water treatment, in the pulp and paper industry, the power industry, shipping and oil industries and in public health. For example, the detachment of microorganisms from biofilms in cooling towers may cause the release of pathogenic organisms such as *Legionella pneumophila* in aerosols (Characklis and Cooksey, 1983). Fouling can also lead to a serious failure of metal structures through corrosion.

### 1.3 CORROSION OF METALS IN AQUEOUS ENVIRONMENTS

Corrosion is an electrochemical process involving a flow of electricity between certain areas of a metal surface through an electrolyte. When a metal is immersed in water it dissolves at anodic sites leaving behind an excess of electrons ( $M \rightarrow M^{X+} + Xe$ ). Removal of the electrons (cathodic reaction) by oxygen in alkaline solution ( $\frac{1}{2}O_2 + H_2O + 2e \rightarrow 2OH^-$ ) or by protons under acidic conditions ( $2H^+ + 2e \rightarrow 2H$ ) causes an increase in metal dissolution, therefore corrosion. The current flow induces a change at the interface, which determines the rate of the overall process occurring at the electrochemical cell. The corrosion reaction tends to slow down as a result of corrosion product formation at the interface. The term polarisation is generally used to express this effect. Conversely any accelerating effect on the corrosion reaction is called depolarisation. Metal surfaces become covered with protective layers which form during the reaction of the metal with a corrosive medium. In general the passive layers have a thickness of 1-10 nm. The density and structures of these layers are of major significance in determining the resistance of metals to the various possible corrosion processes. Loosely adherent, porous layers cannot protect the underlying metal, allowing a uniform removal of material from the surface to take place. Strongly adherent, dense, passive layers protect the metal, but conceal the danger of pitting corrosion occurring where the layer has been destroyed or damaged. If damage of the layer cannot be repaired before the penetration of the anions from a corrosive medium then a local corrosion couple is formed between the cathodic layer and the anodic base material resulting in dissolution of the metal. This is shown diagrammatically for ferrous metal in Figure 3. If the metal ions show little tendency towards hydrolysis and if the metal surface shows good passivity the local electrochemical couples can give rise to deep, pin-hole type dissolution of the material. If the passivity is poor and the tendency to hydrolysis is greater the observed surface damage is in the form of shallower pits.

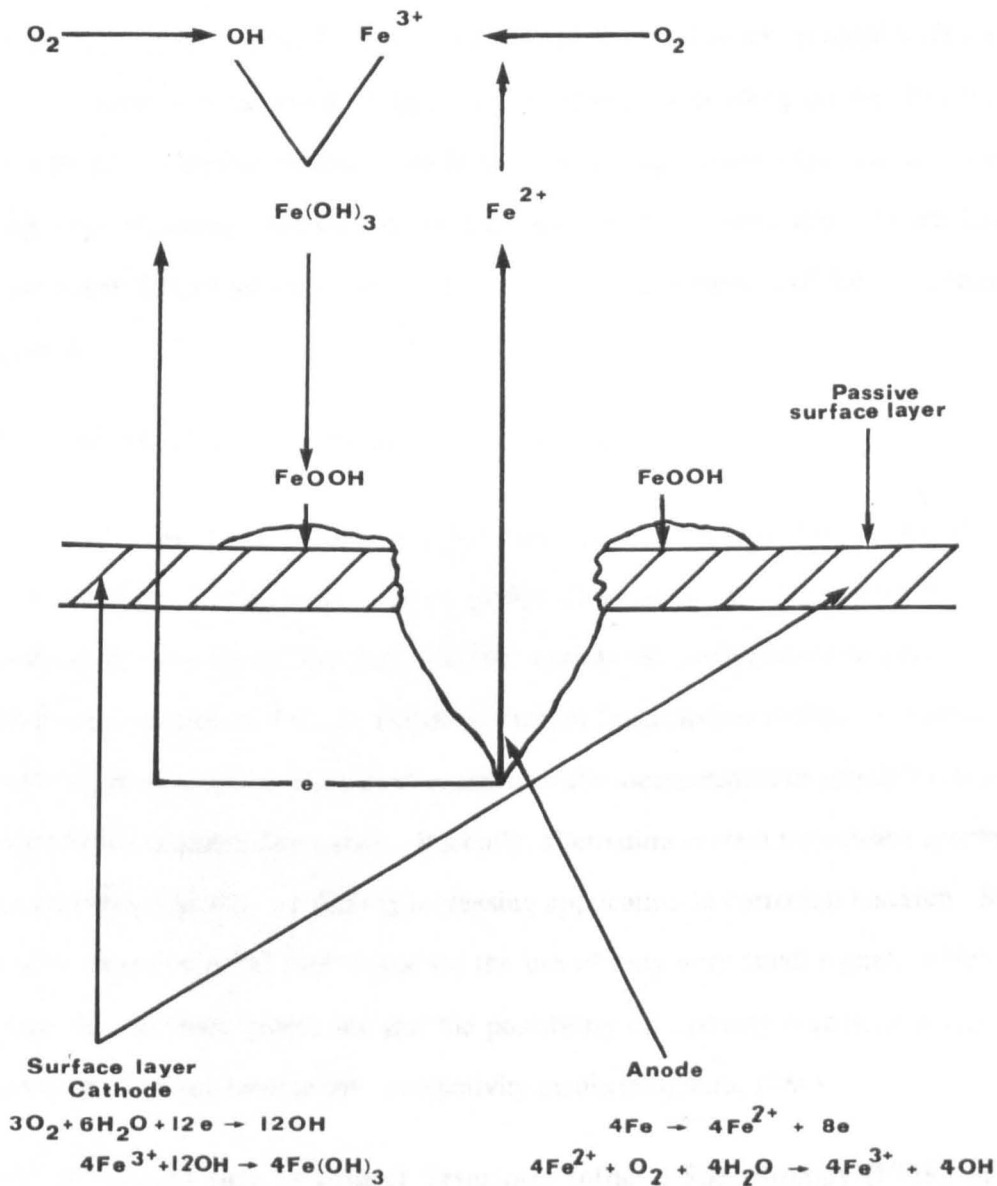

Fig.3 The formation of a localised electrochemical corrosion couple at a disruption in the passive layer of ferrous material

The lower the tendency that a medium has to cause the formation of a passive layer, the more uniform is the chemical attack. All localised chemical attack on metal surfaces results from the formation of localised corrosion couples. Depending on the distribution of cathodic areas, a distinction can be made between pitting corrosion and selective corrosion. In the case of pitting corrosion all the constituents of the metal structure are dissolved, whilst in the case of selective corrosion only a particular element of the microstructure is removed.

### 1.3.1 METHODS OF CORROSION ASSESSMENT

The conventional means of evaluating the corrosion of metals has been to measure the loss of weight of the metal over a given period of exposure to the environment. Other techniques involve electrochemical methods such as the measurement of potential changes with the application of a direct electrical current (polarisation resistance measurements, potentiodynamic polarisation measurements) or the measurement of spontaneous galvanic current between dissimilar metals. Recently, alternating current impedance spectroscopy measurements (ACIS) are finding increasing application in corrosion research. Some of the advantages of ACIS techniques are the use of only very small signals which do not disturb the electrode properties and the possibility of studying corrosion reactions and measuring corrosion rates in low conductivity media (Sequeira, 1988).

Novel techniques such as Fourier Transform Infrared Spectroscopy (FTIR) or Auger Spectroscopy provide powerful tools in investigating the corrosion behaviour of specific systems. Scanning electron microscopy (SEM) observations of corroded surfaces are often performed to visualise and analyse the type of damage occurring. Corrosion products accumulated on the metal surface can be identified by energy dispersive X-ray analysis (EDAX). The EDAX system consists of an X-ray detector incorporated into an electron

microscope. Upon ionisation, atoms in the analysed material release energy as electrons drop back from their excited to their basic state. The excited X-ray energy characteristic for each atom is the difference between energy levels of the states. The identity and quantity of the atoms emitting the energy (photons) are seen as peaks in the spectrum. The EDAX system provides a rapid method of analysis of material components by giving a simultaneous display of all elements present in the sample. The location of peaks in the spectrum identifies their energy and hence the type of element emitting the X-rays. The size of the peak quantifies emitting elements.

#### **1.4 MICROBIALLY INDUCED CORROSION OF METALS**

Microbial corrosion is defined as the deterioration of metals occurring under aerobic or anaerobic conditions induced by the activities of microorganisms such as bacteria, fungi and algae. The most important corrosion causing organisms are the sulphate reducing bacteria (SRB) such as *Desulfovibrio* species (Iverson, 1987), sulphur oxidising bacteria such as *Thiobacillus* (Bos and Kuenen, 1983), iron oxidising bacteria such as *Gallionella* (Tatnall, 1981) and some of the *Pseudomonas* species (Obuekwe et al., 1981; Salvarezza et al., 1979). The fungus *Hormoconis resinae* is considered as the most active species concerned with corrosion of aluminium and its alloys (Hendey, 1964; Parberry, 1968) and of the algae several marine species are implicated in fouling on offshore oil platforms (Edyvean and Terry, 1983).

The forms of corrosion which can be stimulated by the interaction of microorganisms with metals are numerous and range from general pitting, crevice and stress corrosion cracking to enhancement of corrosion-fatigue, intergranular stress cracking and hydrogen embrittlement and cracking (Iverson, 1987). Most cases of microbial corrosion are characterised as localised corrosion.

Microorganisms influence corrosion by changing electrochemical conditions at the metal surface, hence electrochemical techniques are generally applied in the investigation of microbially induced corrosion (Dowling et al., 1988). A review of the electrochemical biocorrosion monitoring techniques was recently presented by King and Eden (1989). The measurements are often conducted in culture media which are complex electrolytes containing high concentrations of aggressive anions. Microbial colonisation of metals can drastically change the metal resistance to corrosion by locally changing the type and concentration of anions, pH, and oxygen as well as by introducing diffusional barriers to the transport of chemical species at the metal/solution interface. The presence of a complex layer of corrosion products, cells and extracellular substances may lead to significant changes in the electrochemical behaviour of the metal and drastically modify the results of conventional electrochemical techniques. These can, therefore, be very difficult to interpret. Hence alternative methods such as Auger spectroscopy (Chen et al., 1988) and FTIR (Jolley et. al., 1990) are very useful in investigating microbially induced corrosion.

#### 1.4.1 MEASUREMENT OF MICROBIAL CORROSION BY POTENTIODYNAMIC POLARISATION TECHNIQUE

The potentiodynamic polarisation method of corrosion detection is frequently used in assessing microbially induced corrosion. The technique involves polarising the electrode probes with a linear voltage ramp over a wide potential range and monitoring the current response. The potential of the corroding metal is measured by determining the voltage difference between the metal immersed in a medium (working electrode) and an appropriate reference electrode such as the saturated calomel electrode. Often a third electrode is included (an auxiliary electrode) to complete the electrical circuit with the working electrode. The specimen is initially polarised in the active (or cathodic) direction and the potential-current density curve is measured over several hundred millivolts to the open



circuit corrosion potential, varying the applied potential in discrete steps. At the corrosion potential, the applied potential is zero and the measured cathodic current density approaches zero. The specimen is then polarised in the noble (or anodic) direction. The measurements are performed using a potentiometer, or a high impedance digital voltmeter. The resulting current-potential diagrams (polarisation plots) have a range of shapes which correspond to different forms of corrosion behaviour. Figure 4 shows examples of anodic polarisation curves exhibiting active (1), active-passive (2) and passive (3) behaviour. A potentiodynamic anodic polarisation plot can yield important information such as the ability of a metal to passivate spontaneously in the particular medium, the potential region over which the specimen remains passive and the corrosion rate in the active region. The pitting potential values  $E_p$  and  $E_{pp}$  can also be determined by measurement of the anodic polarisation curves.  $E_p$  is called pitting potential and represents the potential value at which the current density begins to increase drastically in the passive range in solutions containing aggressive anions.  $E_{pp}$  is the protection potential, below which no pitting occurs and above which pits already nucleated can grow. The use of  $E_p$  value as an indicator of corrosion in microbial environments has been discussed by Salvarezza et al. (1979). Figure 5 gives a schematic representation of a pitting curve.

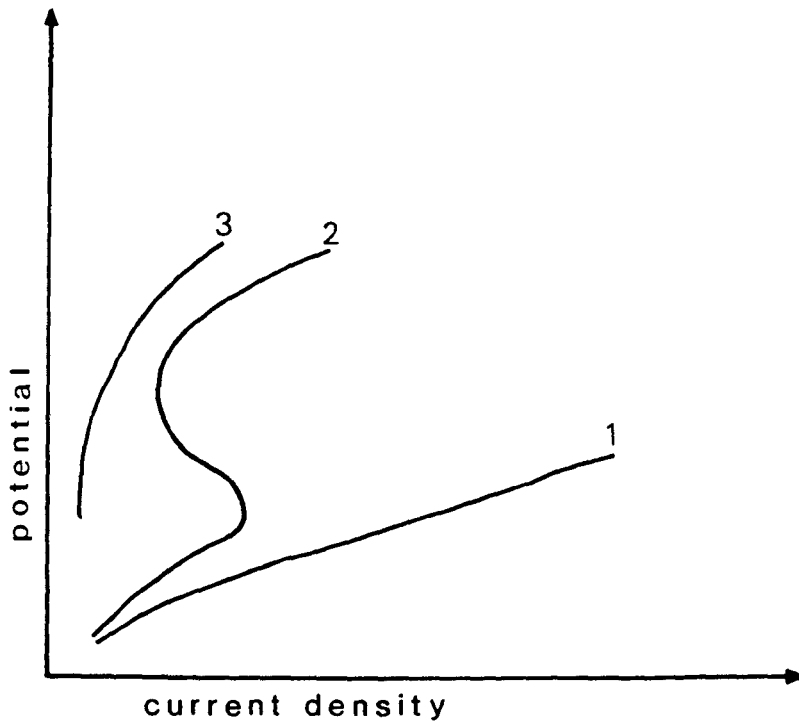

**Fig.4 Anodic polarisation curves of mild steel**

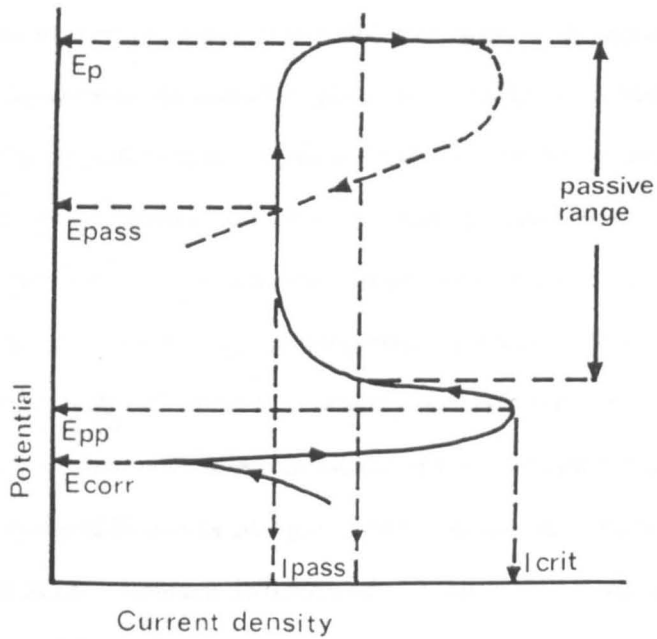

- $E_{corr}$  -corrosion potential
- $I_{crit}$  -critical current density
- $I_{pass}$  -passivation current density
- $E_{pp}$  -protection potential
- $E_p$  -pitting potential
- $E_{pass}$ -passivation potential

**Fig.5 Schematic representation of a pitting curve**

## **1.5 ROLE OF BIOFILMS IN CORROSION OF METALS**

The physical presence of microbial cells on a metal surface as well as their metabolic activities has an impact on electrochemical processes. The adsorbed cells grow and reproduce forming colonies that produce physical anomalies on a metal surface resulting in the formation of local cathodes and anodes. Non-uniform colonisation by bacteria results in the formation of differential aeration cells where areas under respiring colonies are depleted of oxygen relative to surrounding noncolonized areas. Colony formation gives rise to differences in potential and, consequently, corrosion currents. Under anaerobic conditions the areas under the respiring colonies become anodic and the surrounding areas become cathodic. A mature biofilm composed of microorganisms and their extracellular products prevents the diffusion of oxygen to cathodic sites and the diffusion of aggressive anions to anodic sites. Outward diffusion of metabolites and corrosion products is also impeded. If the aerobic respiration rate within the film is greater than the oxygen diffusion rate through the film, a change occurs in the cathodic reaction mechanism.

Aerobic and anaerobic organisms coexist in naturally occurring biofilms in oxygenated environments. A single type of microorganism can simultaneously affect electrochemical processes via several mechanisms such as metal oxidation (Ghiorse, 1984), metal reduction (Obuekwe et al., 1981), organic acid production (Burnes et al., 1967; Little et al., 1986), release of enzymes (Booth et al., 1967) hydrogen production (Walch and Mitchell, 1983), or secretion of extracellular polymeric substances (Geesey et al., 1986; Dexter and Yao, 1987; Nivens et al., 1986). The synergistic communities formed by microorganisms can affect electrochemical processes accomplishing things which individual species cannot, for example metal-depositing bacteria are likely to depend on sulphate reducing or other anaerobic bacteria to maintain conditions required for their growth (Ghiorse, 1984; Tatnall, 1981; Miller and Tiller, 1970). Synergistic activities in mixed bacterial cultures may lead to

increased metal corrosion (Gaylarde and Johnson, 1982; Dowling et al., 1987). Cell death or lysis within a well-developed biofilm does not necessarily mean a termination of the influence on electrochemical processes (Chatelus et al., 1987). The deposits containing extracellular products create differential aeration cells that may persist after cell death (Booth and Tiller, 1962; Miller and Tiller, 1970). Recent techniques used in studying the shifts in microbial community structure within a biofilm and its impact on corrosion include the detection of lipid biomarkers that are characteristic for different classes of microbes (Dowling et al. 1986) and a nondestructive method for measuring dissolved oxygen and pH using ultramicroelectrodes (Characklis et al., 1988). Predictive theoretical and experimental models of the kinetics and stoichiometry of biofilm formation are under development to gain better understanding and control over the process of biofouling (Bakke et al. 1988).

Methods of control of microbial corrosion include the use of protective coatings such as epoxy compounds and resins (Iverson, 1987), cathodic protection by the application of an impressed voltage to a metal (Guezennec and Therene, 1988) and the use of chemical inhibitors (biocides) such as chlorine, phenolics and aldehydes (Bessems, 1983) .

## **1.6 THE ROLE OF BACTERIAL EXOPOLYMERS IN CORROSION OF METALS**

The ability of bacterial exopolymers to bind metal ions has been demonstrated in several systems ( Hsieh et al., 1985; Mittelman and Geesey, 1985). Polymers from different bacteria exhibit different binding capacity for the various metal ions (Ford et al., 1988) . The polysaccharide composition of bacterial polymers varies amongst different strains. These polysaccharides may react with metallic ions via weak electrostatic bonds with hydroxyl groups on neutral polymers or via salt bridges with carboxyl groups such as charged carboxylic acid residues of uronic acids on acidic polymers (Stojkovski et al.,

1986). Such interactions may lead to preferential oxidation of particular metal species creating metal concentration cells and thus enhancing corrosion. A correlation between a polymer's metal-binding ability and corrosion has been proposed (Geesey et al., 1986; Little and al., 1986; Jolley et al., 1988). The exopolymer of *P. atlantica* has been shown to enhance corrosion of steel (White et. al., 1986) and copper (Jolley et al., 1990) and Geesey et al. (1988) have shown that acidic polysaccharides increase the ionisation of copper at the metallic surface causing thinning of the copper film. The involvement of exopolmer-producing *Pseudomonas* strains in the pitting corrosion of copper water pipes has been reported (Fischer et. al, 1988; Keevil et al., 1989). However it has been suggested that in this case proteins present in the exopolymer may have a stronger effect on metal-binding than polysaccharides (Angell and Chamberlain, 1991).

To elucidate the involvement of exopolymer components in the biocorrosion of metals it is therefore important to characterise quantitatively and qualitatively exopolymers present in biofilms formed on metal surfaces and released into a bulk phase. Free polymer can compete with planktonic cells for free binding sites on the solid substrate (Brown et al., 1977), thus changing surface characteristics.

## **1.7 INVOLVEMENT OF SRB IN CORROSION OF METALS**

Sulphate reducing bacteria (SRB) are the most significant anaerobes found in microbial corrosion processes (Hamilton, 1985). The SRB are a group of strict anaerobes but can survive for a long periods of time in the presence of oxygen. They are taxonomically diverse but physiologically and ecologically homogenous. SRB are Gram negative and have a high requirement for iron. They conduct sulphate respiration using sulphate as the terminal electron acceptor, reducing it to sulphide. SRB produce large quantities of hydrogen sulphide, creating reducing anoxic environments (Postgate, 1984). Hydrogen plays an important role in the metabolism of the SRB which possess hydrogenase enzymes

in various cellular compartments such as cytoplasm (Cord-Ruwisch and Widdel, 1986), periplasm and cytoplasmic membrane (Chatelus et al., 1987).

The electrochemical interpretation of SRB-induced corrosion was first presented by von Wolzogen Kuhr and van der Vlugt (1934). The following reactions were proposed to explain the processes:

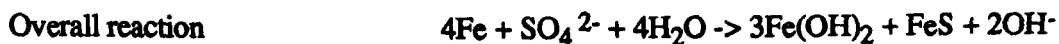
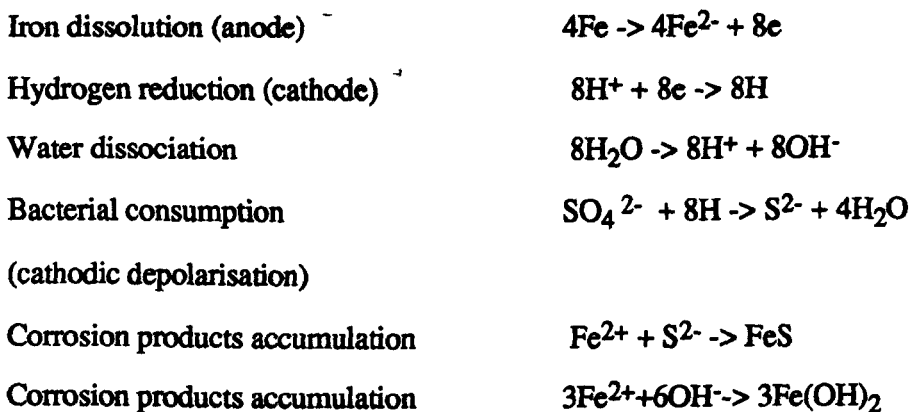

The overall process was described as the cathodic depolarisation theory based on the assumption that the hydrogenase system of the SRB removes the atomic hydrogen that accumulates on the iron surface. The electron removal as a result of hydrogen utilisation results in cathodic depolarisation and forces more iron to be dissolved at the anode. The direct removal of hydrogen from the surface is equivalent to lowering the activation energy for hydrogen removal by providing a "depolarisation" reaction. Booth and Tiller (1962) provided additional evidence in favour of the depolarisation theory using polarisation techniques and weight loss measurements versus hydrogenase activity of SRB in batch cultures. Since it was later found that nonhydrogenase producing SRB strains can also stimulate corrosion, Miller and Tiller (1970) have proposed cathodic depolarisation induced by microbially produced FeS. It was demonstrated that weight losses of mild steel were

proportional to the concentration of ferrous sulphide present and the stoichiometry of the particular ferrous sulphide minerals. The formation of iron sulphide was therefore proposed to be a corrosion accelerating factor (King et al., 1973; Booth et al., 1968). Costello (1974) implicated dissolved  $H_2S$  produced by SRB as responsible for cathodic depolarisation. Further evidence was provided by Togano et. al. (1975) who also suggested acceleration of both anodic and cathodic reactions by SRB-produced sulphide. Salvarezza and Videla (1980), using potentiostatic polarisation techniques, demonstrated that SRB behave similarly to chemically added sulphide in breaking down the passivity of mild steel in seawater. The impact of oxygen on the obligate, anaerobic SRB was examined by Hardy and Bown (1984). Corrosion rates, determined by weight-loss measurements and by electrical resistance, increased with addition of oxygen. The attack was confined to areas beneath tubercles that consisted of loosely adherent material as opposed to the hard tightly adherent films on uncorroded metal. It was concluded that the presence of tubercles fixed the anode and forced the cathodic reaction to occur on the adherent sulphide film. Other mechanisms involved in corrosion of metals by SRB also have been proposed such as the effect of phosphorus compounds on passivity breakdown of steel (Iverson and Olson, 1983; Weimer et al., 1988). Whatever the mechanism, SRB-induced corrosion is a significant cause of the corrosion of underground structures such as pipelines, offshore oil recovery platforms, well casings, pumps, oil tanks, refinery equipment, gas storage tanks, cooling systems and heat exchangers (Pope, 1986; Iverson, 1987). The corrosion of iron and ferrous metal alloys by SRB causes severe economic losses by the destruction of industrial and process equipment and devaluation of industrial products such as oil and natural gas (Pankhurst, 1968; Hamilton, 1985).

Preventing the adhesion of SRB cells to metal surfaces retards the rate of corrosion in laboratory experiments (Gaylarde and Johnston, 1980) while the presence of other genera



of bacteria, perhaps enhancing adhesion, may increase corrosion (Gaylarde and Johnston, 1982; Gaylarde and Videla, 1987).

Studies of the mechanism involved in attachment of SRB to metal surfaces, the production and composition of their exopolymers and the nature of the biofilm subsequently formed on SRB-colonised surfaces is therefore paramount in gaining a better understanding of SRB-induced corrosion.

## **1.8 THE INVOLVMENT OF BACTERIA OF THE GENUS *PSEUDOMONAS* IN CORROSION**

*Pseudomonas* is a Gram-negative, aerobic, rod-shaped bacterial genus, whose members are very widely distributed in the environment. They have been reported in connection with cases of corrosion. A strain of *Pseudomonas* isolated from a corroded pipe system carrying crude oil has been found to reduce ferric iron to the soluble ferrous form, thus exposing a fresh metal surface to the corrosive environment (Obuekwe et al., 1981). The accelerated corrosion of stainless steel in seawater by *Pseudomonas atlantica* and its exopolymer has been demonstrated by White et al. (1985). Strains of *Pseudomonas* have been isolated from copper water pipes showing pitting corrosion (Angell and Chamberlain, 1991).

*Pseudomonas* are very prevalent in industrial water environments where their primary role in corrosion appears to be in colonising metal surfaces, creating oxygen-depleted microenvironments for SRB growth, initiating differential aeration cells and excreting corrosive acids (King, 1982; Videla et al., 1990).

*Pseudomonas* are early colonisers of surfaces in aquatic environments (Corpe, 1970) and can play an important role in facilitating the build up of a biofilm. Therefore investigations

of their adhesion mechanisms, secretion of extracellular polymers and impact on corrosion of metals in the presence of other bacterial species such as SRB is of obvious interest.

## **1.9 AIMS OF THE INVESTIGATION**

The aim of this investigation is to elucidate the process of biofilm formation on mild and stainless steel surfaces exposed to pure and mixed cultures of the bacteria *P. fluorescens* and *D. desulfuricans* and to establish the role of these biofilms in corrosion of steel.

Particular attention is paid to:

- a) mechanisms involved in early attachment of bacterial cells to steel surfaces initiating the formation of biofilm (primary stage in biofilm development)
- b) production and chemical composition of free and biofilm-bound bacterial exopolymers (secondary stage of biofilm formation).

It is hoped that a more detailed appreciation of adhesion processes and biofilm formation will eventually aid in the control of fouling and corrosion of metal structures caused by bacteria.

## **CHAPTER TWO**

### **MATERIALS AND METHODS**

## 2.1 ORGANISMS

*Desulfovibrio desulfuricans subsp. desulfuricans* New Jersey (NCIMB 8313), originally isolated from the interior of a corroding cast iron heat exchanger in 1940 (Postgate, 1984) was grown in 150 ml of Postgate medium C (Postgate, 1984) (see Appendix) in screw-capped glass bottles at 30°C. For experimental purposes bacteria were subcultured every two weeks by inoculating 10 ml of a 14-day culture into bottles containing 100 ml sterile Postgate C. Bottles were then completely filled with medium C to minimise the air space above the culture. All procedures were carried out aseptically. In all experiments, 5 day old cultures were used as a source of inoculum. Stock cultures of *D. desulfuricans* were grown in Postgate medium B (Postgate, 1984) in universal bottles at 30°C. Cultures were routinely checked for purity by spreading on nutrient agar and incubating aerobically and anaerobically for up to 9 days.

*Pseudomonas fluorescens*, originally isolated from a contaminated metal working fluid (C.Gaylarde, personal communication) and identified by the API20NE strip was grown on nutrient agar plates at 24°C. Bacteria were subcultured on to fresh plates at weekly intervals. In all experiments 48h cultures were used to provide the inoculum. Stock cultures of *P. fluorescens* were grown on nutrient agar slopes for 24h at 24°C and then stored at 4°C for up to 8 weeks.

## 2.2 TRANSMISSION ELECTRON MICROSCOPY (TEM)

One drop of bacterial suspension in distilled water was placed on a carbon coated formvar grid using a sterile pasteur pipette. The suspension was left on the grid for 15 min and then the excess liquid was removed with filter paper. A drop of 5% uranyl acetate was deposited on the grid. After staining for 15 min at room temperature the excess stain was removed with filter paper and the grid examined with an AEI6B TEM operating at 100 kV. All reagents used were of EM grade and were purchased from TAAB, England.

## 2.3 PRODUCTION AND PURIFICATION OF ANTIBODIES AGAINST BACTERIAL LIPOPOLYSACCHARIDES (LPS)

Polyclonal antibodies were raised against LPS of *D. desulfuricans* and *P. fluorescens* to investigate the involvement of LPS in adhesion of these bacteria to steel surfaces.

### 2.3.1 ANTIBODY PRODUCTION

New Zealand White rabbits, initially bled for preimmune serum, were immunised by subcutaneous injection. The antigen consisted of 5 mg of either *Desulfovibrio* or *Pseudomonas* LPS prepared as described in section 2.7.1 in 1 ml distilled water plus 1 ml Freund's Complete Adjuvant. After 1 week the procedure was repeated using Freund's Incomplete Adjuvant. 7 days after the last injection, the animals were bled from the ear vein. The nonimmune and immune sera were separated from the clotted whole blood by centrifugation (1000g for 15 min).

### 2.3.2 PURIFICATION OF IMMUNOGLOBULIN (Ig)

Ig was partially purified from the antisera raised against bacterial LPS by salt precipitation using 32% w/v sodium sulphate (Phillips et al., 1984). An equal volume of sodium sulphate (32% w/v) was added drop-wise to the serum with continuous stirring. The mixture was left to stand at room temperature for 30 min and centrifuged at 1000g for 15 min at 4°C to collect the precipitate. This was redissolved in the same volume of 0.15M phosphate buffered saline (PBS) pH 7.2 (see Appendix) and dialysed for 3 days against 5 changes of 0.15M PBS at 4°C. The dialysed product was frozen in liquid nitrogen and freeze dried for 15h. The lyophilised samples were stored at -20°C.

### 2.3.3 TESTING OF PURIFIED Ig BY CELL AGGLUTINATION

The specificity of the Ig raised against LPS of *P. fluorescens* (A-LPS<sub>PF</sub>) and LPS of *D. desulfuricans* (A-LPS<sub>DD</sub>), together with a similar preparation produced for *D. vulgaris* (Woolwich) by Dr. L.K.Siew (previously at the City of London Polytechnic) was tested by

agglutination of bacterial cells on glass slides. The preimmune rabbit serum (PRS) purified as described in section 2.3.2 served as control. A drop of bacterial cell suspension in sterile saline was deposited on the surface of a glass slide. A small amount of lyophilised A-LPS and lyophilised PRS were dissolved in 0.1 ml sterile saline and an aliquot of each of these added with a wire loop to the cell suspensions. The slide was agitated gently for a few minutes and any cell agglutination was detected macroscopically and under a light microscope at a magnification of x400.

## **2.4 CELL ADHESION STUDIES**

Each of the following experiments was repeated at least three times and the results were statistically evaluated by means of two-tailed unpaired t-tests.

### **2.4.1 METAL SURFACES USED IN ADHESION EXPERIMENTS**

Cylindrical stubs (7mm diameter x 3mm depth) of mild steel (EN1A;BS570) and stainless steel (EN58J; BS316) were manufactured in the Polytechnic workshop. The composition of the steel is presented in Table 1A of the Appendix. Stubs were sterilised dry by autoclaving in water-tight containers. Before exposure to bacterial cultures the stubs were immersed in 70% alcohol, flamed and placed inside sterile universal bottles and allowed to cool. All procedures were carried out in a laminar flow cabinet.

### **2.4.2 PREPARATION OF CELLS FOR ADHESION EXPERIMENTS**

Cells of *D. desulfuricans* were harvested by centrifugation (500g for 30 min) from batch cultures grown as described in section 2.1. The pellet was resuspended in sterile distilled water or medium C in universal bottles. Cells of *P. fluorescens* were collected from the surface of the nutrient agar plate (section 2.1) by adding 5 ml of sterile distilled water or medium C and washing off the cells by gentle agitation. Cells were transferred into sterile universal bottles and vortexed briefly to obtain uniform suspensions. Both *Desulfovibrio* and *Pseudomonas* cells were resuspended in sterile distilled water or medium C and adjusted to the required concentrations after enumeration using an improved Neubauer

haemocytometer. Stubs were added, after the addition of any potential inhibitors of adhesion (sections 2.4.3. to 2.4.6) in an aseptic manner.

#### 2.4.3 LECTIN TREATMENT

Lectins concanavalin A (ConA) or wheat germ agglutinin (WGA) (Sigma) were dissolved in 1 ml of medium C and added aseptically (by filtration through a Millipore 0.22  $\mu\text{m}$  pore size filter) to 9 ml of bacterial cell suspension to give a final concentration of lectins of 125  $\mu\text{g/ml}$ . Bacteria were preincubated with lectin at room temperature for 30 min prior to exposure to mild steel stubs. Controls consisted of bacteria in medium C to which 1 ml of medium C had been added in place of lectin.

#### 2.4.4 SUGAR-LECTIN TREATMENT

Sugar inhibitors of WGA and ConA, mannose (man), sucrose (suc), glucose (glc), N-acetyl-D-glucosamine (glcNAc) and chitobiose (chit) (all purchased from Sigma) were added to bacterial suspensions after filtration as described for lectins (section 2.4.3). Final sugar concentrations were those shown in results (chapter 3). Sugars were added immediately after the lectins. Bacterial cells were preincubated with lectins and sugars for 30 min before mild steel stubs were placed in the suspensions.

#### 2.4.5 ENZYME TREATMENT

Enzymes glucosidase, N-acetylglucosaminidase and crude pronase (all from Sigma) were added as described in section 2.4.3 to bacterial cell suspensions to give the required concentrations (see section 3). Cells were preincubated with enzymes for various lengths of time (1 to 2 h) prior to the introduction of mild steel stubs.

#### 2.4.6 TREATMENT WITH ANTIBODIES RAISED AGAINST BACTERIAL LIPOPOLYSACCHARIDES (A-LPS)

Bacterial cells were preincubated with 400  $\mu\text{g/ml}$  purified A-LPS of *D. desulfuricans*, *D. vulgaris*, or *P. fluorescens* for various lengths of time (1 to 4.5 h). Antibodies were

prepared as described in sections 2.3.1 and 2.3.2 and were sterilised prior to addition to bacterial suspensions by filtration as described for lectins (section 2.4.3). Control bottles contained equal concentrations of protein precipitated from preimmune rabbit serum by the same method as A-LPS.

#### **2.4.7 MEASUREMENT OF ADHESION**

Adhesion of bacterial cells to steel surfaces was assayed by epifluorescence microscopy. After exposure to treated or untreated bacterial suspensions, stubs were removed and washed gently to remove unattached cells. This was accomplished by passing the stubs several times under the surface of sterile distilled water in sterile petri dishes. The washed surfaces were then stained for 5 min with 0.001% acridine orange. The dye was sterilised and cleared of particulate matter by filtration prior to use. After subsequent washing of the stubs with sterile distilled water they were placed on glass slides and examined immediately at a magnification of x400 with a standard Zeiss light microscope fitted with epifluorescent illumination and a halogen lamp. The number of cells adhering to the surfaces were estimated by counting fluorescing cells within an area of microscope field delineated by an etched eyepiece (0.03 mm<sup>2</sup>). Ten to 20 such areas were randomly selected and counted on each stub. This represented up to 2% of the total surface area (3.14 mm<sup>2</sup>).

### **2.5 BIOFILM PRODUCTION AND MICROBIOLOGICAL ANALYSIS**

#### **2.5.1 METAL SURFACES USED FOR GROWTH OF BIOFILMS**

Mild steel (EN1A;BS970) and stainless steel (BSO21134) coupons (1.5cm x 10cm x 0.16mm) were sterilised dry by autoclaving in watertight containers. Before inoculation with bacterial cultures the coupons were immersed in 70% alcohol, flamed, and placed vertically inside glass screw-capped flasks containing 135 ml of sterile medium C (5 coupons per flask). The coupons were positioned to encourage biofilm growth on both sides of the coupons.



### 2.5.2 BIOFILM GROWTH

Cells of *D. desulfuricans* were harvested from broth cultures (section 2.1) by centrifugation (500g for 30 min) and resuspended in sterile medium C. Cells of *P. fluorescens* were washed from the surface of the nutrient agar plate (section 2.1) with sterile medium C. Cell suspensions of pure and mixed cultures of *D. desulfuricans* and *P. fluorescens* were adjusted by using an improved Neubauer hemocytometer to give a final concentration of  $10^5$  cells per ml on inoculation into coupon-containing flasks and control, coupon-free flasks. Flasks were set up in triplicate. Each set of 3 contained growth medium and either 5 stainless steel or 5 mild steel coupons or no coupons (control). Flasks were incubated for 7 and 28 days at 30°C. The whole procedure was repeated 3 times.

The viability of planktonic *Pseudomonas* in the media after 28 days was determined by the surface spread method on nutrient agar plates. Colonies were counted after 36h and again after 60h. The viability of planktonic *Desulfovibrio* was assessed by spreading 0.5 ml of incubating medium over the surface of solid Postgate E medium (Postgate 1984) (see Appendix) and incubating the plates in an anaerobic cabinet for 14 days at 32°C. The appearance of black colonies indicated growth of the cells. For determination of sessile bacteria viability, coupons were removed aseptically from the incubating media and placed on either nutrient agar plates or on solid medium E. Coupons were firmly pressed to the surface of the plates and removed. Plates were incubated aerobically at room temperature for 36h and anaerobically at 32°C for up to 14 days. Sessile counts were performed according to the method described by Moreno et al. (1990). The biofilm was removed from both surfaces of the coupons by scraping with a sterile razor blade into 5 ml sterile saline. This suspension was then treated as for planktonic samples. *D. desulfuricans* was enumerated in agar shake tubes of medium E. The tubes were examined for up to seven days. Blackening indicated growth of the cells. Numbers of black colonies developing were scored where possible (at higher dilutions). *P. fluorescens* was counted using the surface spread method on nutrient agar plates. Colonies were counted after 36h and again after 96h.

### **2.5.3 RECOVERY OF BIOFILMS FOR CHEMICAL ANALYSIS**

Mild and stainless steel coupons were removed aseptically from the 7 and 28 day old cultures, immediately plunged into liquid nitrogen (to avoid formation of oxides) and freeze-dried. Lyophilised biofilms were removed from the surfaces with a razor blade and the total biofilm from each set of 15 coupons combined and stored at -80°C.

### **2.5.4 TREATMENT OF 7 DAY OLD BIOFILM SAMPLES PRIOR TO CHEMICAL ANALYSIS**

Biofilms were treated by resuspending in 10 ml of double-distilled water (ddH<sub>2</sub>O), heating at 40°C for 10 min, vortexing for 10 min and centrifuging at 500g for 30 min. The supernatants were collected and the pellets were extracted a further two times. All washes were combined and spun at 10000g for 30 min. The supernatants, now essentially free from metal oxides, sulphides and cells, were lyophilised. Treated biofilms were stored at -80°C.

### **2.5.5 SCANNING ELECTRON MICROSCOPY (SEM) OF BIOFILMS**

Stainless and mild steel stubs and coupons incubated with bacterial cultures for varying lengths of time (1h to 6 weeks) as described in sections 2.4.2 and 2.5.2 were removed from the cultures aseptically. Stubs were rinsed in 0.1M cacodylate buffer and prefixed in 0.5% glutaraldehyde in 0.1M cacodylate buffer pH 7.4 for 1h at 4°C. Samples were then rinsed twice in 0.1M cacodylate buffer and fixed for 3h in 2.5% glutaraldehyde in the same buffer at 4°C. After washing 3 times in buffer, samples were post fixed in 2% osmium tetroxide for 2h at room temperature in a fume cupboard. Stubs were removed from osmium and dehydrated in 30, 50, 70, 90, and 100% isopropanol-water or acetone-water series (15 min in each solution). Samples were then frozen in liquid nitrogen and freeze-dried under vacuum for 16h. After mounting on aluminium stubs, samples were sputter coated with gold and observed at 15kV with a Super Mini SEM (International Scientific Instruments). In later experiments, freshly withdrawn mild steel (MS) and stainless steel

(SS) coupons were processed in a similar way as MS and SS stubs. The prefixation in 0.5% glutaraldehyde was extended to 24h and the fixation in osmium tetroxide was omitted (to avoid reaction between steel and osmium). Dried coupons were cut into segments (1.55 cm x 3 cm x 0.16 cm), mounted, sputter coated as described for stubs and examined under a Hitachi S450 scanning electron microscope at an accelerating voltage of 15 or 20kV. All above reagents were purchased from TAAB (England) except for isopropanol and acetone, which were obtained from BDH.

## **2.6 CHEMICAL ANALYSIS OF FREE BACTERIAL EXTRACELLULAR POLYMERIC SUBSTANCES (EPS) AND BIOFILMS**

### **2.6.1 ISOLATION OF FREE EPS**

Free EPS were obtained from the bulk phase of pure and mixed batch cultures of *D. desulfuricans* and *P. fluorescens* grown aseptically for 7 and 28 days in Postgate medium C at 30°C in the presence of mild and stainless steel coupons (15 coupons of each type per assay) (section 2.5.2). Coupons were removed aseptically and cultures (500 ml per trial) were centrifuged for 30 min at 10000 g to remove bacterial cells.

The EPS were recovered from the supernatant by precipitating with 3 volumes of isopropanol for 48h at 4°C. The precipitated polymer was redissolved in double distilled water (ddH<sub>2</sub>O), dialysed against ddH<sub>2</sub>O overnight at 4°C, lyophilised to dryness and stored at -80°C. Controls consisted of EPS harvested from bacterial cultures (500 ml) incubated without steel coupons and of precipitate obtained from 500 ml of 7 day old sterile medium C. The weight of the lyophilised EPS samples was recorded. The whole experiment consisted of three trials.

## 2.6.2 COLORIMETRIC ASSAYS FOR DETERMINATION OF CARBOHYDRATES IN EPS AND BIOFILM SAMPLES

Crude EPS samples 7 and 28 days old, harvested as described in section 2.6.1, and crude and treated biofilm samples (2.5.3. & 2.5.4) 7 and 28 days old were assayed for the presence of neutral hexoses following the phenol-sulphuric acid procedure of Dubois et al. (1956).

EPS and biofilm samples were dissolved in ddH<sub>2</sub>O (0.5 mg in 0.5 ml ddH<sub>2</sub>O). Phenol reagent (0.5 ml) prepared as a 5% w/v solution of redistilled phenol in ddH<sub>2</sub>O, was added to each sample followed by the rapid addition of 2.5 ml of sulphuric acid reagent (0.5% w/v hydrazine sulphate in concentrated sulphuric acid). The samples were mixed by vortexing, covered with aluminium foil and kept for 2h in the dark at room temperature. The absorbance was measured at 490 nm. Glucose was used as the standard to obtain a calibration curve.

The uronic acid content of the samples was determined by the method of Blumenkrantz and Asboe-Hansen (1973). EPS and biofilm samples were dissolved in ddH<sub>2</sub>O (1 mg in 1 ml ddH<sub>2</sub>O). The samples (0.2 ml) were added to test tubes containing 1.2 ml of ice cold sulphuric acid/tetraborate solution (0.0125M sodium tetraborate in concentrated H<sub>2</sub>SO<sub>4</sub>). The samples were mixed by vortexing and tubes were placed in a 100°C water bath for 5 min. The tubes were cooled on ice and 20 ml of meta-hydroxydiphenyl reagent, (0.15% meta-hydroxydiphenyl in 0.5% NaOH) was added to each tube. The samples were vortexed and the absorbance was measured at 520 nm. Blank samples, prepared as above, containing 20 ml of 0.5% NaOH instead of the meta-hydroxydiphenyl reagent were used to correct for the interference caused by the presence of carbohydrates in the samples. The absorbance produced by the blank sample was subtracted from that of the sample containing meta-hydroxydiphenyl reagent. The uronic acid content of the samples was determined from a curve constructed using glucuronic acid as the standard.

### 2.6.3 GAS CHROMATOGRAPHIC ANALYSES OF CARBOHYDRATES PRESENT IN EPS AND BIOFILMS

The polysaccharides present in free EPS and treated biofilm samples (section 2.5.4) were reduced, hydrolysed and derivatised prior to gas chromatographic analyses. The reduction of polysaccharides was performed according to the modified procedure of York et al. (1985). The hydrolysis and derivatisation of monomeric sugars followed the methods of Fazio et al. (1982) and Quintero et al. (1989) respectively. All procedures were performed in acid washed glassware and all solvents and acids were of reagent grade.

#### 2.6.3.1 Reduction of sugars

Crude polymer samples (15 mg) were dissolved in 2 ml of 8M urea in ddH<sub>2</sub>O and the pH adjusted to 4.75 using 0.025M HCl. Solid 1-cyclohexyl-3-(2-morpholinoethyl)-carbodiimide metho-p-toluene sulfonate (CMC) was slowly added to the solutions with continuous stirring to achieve a CMC: polymer ratio of 10:1 (wt:wt). The pH was maintained at 4.75 with 0.025 M HCl during the addition of CMC and kept at this value for one hour after the addition of CMC. The pH was then adjusted to 7.0 with 2 M HCl, and NaBD<sub>4</sub> (250 mg of NaBD<sub>4</sub> in 3 ml ddH<sub>2</sub>O) was added over a 30 min period using a peristaltic pump at a rate of 0.1 ml / min. During addition of reductant, the pH was maintained at 7.0 using 5M HCl. The control of excessive foaming was achieved by adding 10 to 25 µl of n-octanol. The reaction was allowed to continue for 30 min after the NaBD<sub>4</sub> delivery was completed. The pH of the solution was then reduced to between 5 and 6 with 5M HCl. The solution was placed in dialysis tubing (2000 MW cutoff point) and dialysed against ddH<sub>2</sub>O at 4°C for 24h with 3 water changes. The dialysates were frozen at -80°C and lyophilised to dryness in the freeze-dryer. Traces of boric acid were removed from the dried polymer samples by dissolving in 0.5 ml ddH<sub>2</sub>O, adding 0.5 ml of acetic acid-methanol solution (1:9) and evaporating the methyl borate esters under a stream of nitrogen. The resultant residues were extracted 3 times in 3 x 1 ml of methanol and freeze dried.

### 2.6.3.2 Hydrolysis of sugars.

The reduced, lyophilised exopolymers were dissolved in 0.5 ml of 2M HCl and heated for 2h at 100°C. The samples were then neutralised to slightly acidic pH (between 5 and 6) with 1M NaHCO<sub>3</sub> and freeze dried.

### 2.6.3.3 Derivatisation of sugars.

The monomeric sugars in lyophilised hydrolysates were extracted 3 times with 5, 3, and 2 ml of methanol as follows. The samples were dissolved in methanol, heated for 10 min at 60°C, vortexed for 5 min and centrifuged for 5 min at 400g. The combined methanol fractions were transferred to clean test tubes and dried under a stream of nitrogen in a water bath at 40°C. An internal standard of 100 µl of a 20mM solution of myo-inositol was added to each hydrolysed sample. Each sample was treated with 1 ml of hydroxylamine hydrochloride solution (150 mg in 10 ml pyridine) at 60°C for 1 hour and then with 1 ml of acetic anhydride for an additional hour at the same temperature. The reaction was terminated by the addition of 3 ml of chloroform. The samples were extracted 3 times with 3 ml of a 15% tartaric acid solution to remove unreacted reagents (mainly the pyridine) as described for methanol but excluding heating. The chloroform phases containing the preacetylated aldonitrile sugar derivatives were drawn off with Pasteur pipettes and placed in the refrigerator overnight allowing any residual water and debris to congeal to the walls of the test tubes. The chloroform fractions were transferred to clean test tubes and the chloroform was evaporated under a stream of nitrogen. The samples were stored in the refrigerator at 4°C for chromatographic analyses.

### 2.6.3.4 Preparation of sugar standards for gas chromatography

Pentose and hexose standards (15 sugars (Sigma)) were prepared as 20 mM solutions and derivatised as described in section 2.6.3.3.

#### 2.6.3.5 Gas chromatography

The EPS and biofilm samples and the combined sugar standards were redissolved in 0.5 ml chloroform prior to chromatographic analyses.

Gas chromatography was performed with a Varian model 3700 gas chromatograph with a flame ionisation detector and Varian CDS111 data system. Samples and sugar standards (1  $\mu$ l) were injected in triplicate into a polar 30 m fused silica capillary column, 0.25 mm ID (SP-2330, Supelco Inc., Bellefonte, PA), using splitless injection. The temperature was programmed to rise from 160 to 210°C at a rate of 5°C per min, after which an isothermal period was held for 10 min, followed by a temperature ramp to 225°C at a rate of 5°C per min, and this temperature held for 3 min. Hydrogen was used as the carrier gas at a flow rate of 30 cm per min. The temperature of the injection port and the detector were controlled at 250°C. The run was completed in 32 min.

#### 2.6.3.6 Gas chromatography-mass spectrometry (GC-MS)

GC-MS was performed with a Hewlett-Packard 5890 gas chromatograph and 5970 mass selective detector (MSD). Temperature programmes, MSD parameters and data analysis were controlled with a Hewlett-Packard 59970 MS Chemstation. Samples and sugar standards were injected as 1  $\mu$ l aliquots into a polar 30m fused silica capillary column (DB225-30N, J&W Scientific Inc., Rancho Cordova, CA), with splitless injection and 0.75 min venting time. The temperature was set to rise from 160 to 210°C at 2°C per min, followed by an 18 min isothermal period. The temperature was raised to 225°C at 5°C per min and held for 4 min. The helium carrier gas was operated at a head pressure of 5 lb/in<sup>2</sup> and a column flow rate of 30 cm per sec. The injection port was held at 250°C and the detector at 280°C. The mass spectrometer was autotuned with perfluorotributylamine (PFTBA), the electron multiplier voltage was 2000V. The instrument was used in the selective ion monitoring mode (SIM) for highest sensitivity. Data acquisition was carried out for 50 min.

### 2.6.3.7 Quantification of neutral carbohydrates detected in EPS samples by GC-FID

Sugar standards were used to calculate a response factor (R.F.) for pentoses and hexoses (R.F.= area of inositol/area of sugar) in the EPS samples. The concentrations of individual carbohydrates ( $\mu\text{g}/\text{mg}$  of the polymer) in the samples were calculated as follows: (area of sugar/area of inositol) x R.F. of sugar x moles of internal standard (inositol) x weight of sugar ( $\mu\text{g}$ ) x 1 /weight of the reduced polymer (mg). The integration of the areas under the sugar peaks was performed with GC-FID data system (see Appendix). Software used for these calculations was developed in the laboratory of Professor Geesey at the California State University in Long Beach. The total amount of neutral sugars present in the given EPS sample (TNS) was calculated by multiplying the sum of concentrations of all individual sugars detected in the sample ( $\Sigma\text{CS}^{\text{EPS}}$ ) by the dry weight of lyophilised EPS recovered from the bulk phase ( $\text{Dw}^{\text{EPS}}$ )

$$\text{TNS}^{\text{EPS}} = \Sigma\text{CS}^{\text{EPS}} \times \text{Dw}^{\text{EPS}}$$

The statistical evaluation of the acquired data was accomplished by applying analysis of variance, using the "BIOSTAT" program developed at the City of London Polytechnic.

### 2.6.4 PROTEIN DETERMINATION IN FREE EPS AND BIOFILM SAMPLES

Proteins present in free EPS and in biofilm samples were evaluated quantitatively by colorimetric assay and separated by gel electrophoresis.

#### 2.6.4.1 Colorimetric assay

Crude EPS and biofilm samples (7 and 28 day old) were assayed for the presence of proteins following the method of Lowry et al. (1951) using Folin-phenol reagent. Bovine serum albumin was used as a standard for the calibration curve and the absorbance was recorded at 550 nm.



#### 2.6.4.2 Gel electrophoresis of proteins in free EPS and biofilm samples.

EPS and biofilm proteins were separated by sodium dodecyl sulphate (SDS) - polyacrylamide gel electrophoresis (PAGE), using slab gels (10.2 x 8.2 cm), run on the LKB Midget Electrophoresis unit for 1 hour at constant current (20 mA per gel). The separating and stacking gels contained 10% w/v and 5% w/v acrylamide respectively. LPS samples (1 mg in 250 ml of ddH<sub>2</sub>O) were mixed with an equal volume of 0.125M Tris HCl buffer pH 6.8 containing 1% w/v 2-mercapthoethanol, 0.02% w/v bromophenol blue, 0.04% w/v SDS and 23.2% w/v of 87% glycerol. The mixtures were incubated for 5 min at 100°C, spun for 5 min in a microfuge to sediment any undissolved particles and 20 µl samples were applied to each well of the gel. Proteins on the gel were detected by staining for 1 to 2 hours with PAGE blue 83 Electran (BDS) (0.2g of PAGE blue in 1 litre of acetic acid, isopropanol and dH<sub>2</sub>O (1:1:9)). Gels were then washed with acetic acid-isopropanol mixture (without PAGE blue) to remove the background colour and to visualise protein bands. Gels were stored in this solution until the photographs were taken.

### 2.7 ANALYSIS OF BACTERIAL LIPOPOLYSACCHARIDES (LPS).

#### 2.7.1 EXTRACTION OF LPS

LPS of *Desulfovibrio* and *Pseudomonas* were isolated from outer membranes (OM) of bacterial cells as described by Siew (1987) with slight modification. The method of phenol-water extraction, applied originally to whole bacterial cells, was that of Westphal & Jann (1965). Various polysaccharides, including LPS, can be purified from aqueous solution by adding liquid phenol. At temperatures above 68°C phenol and water are miscible. On cooling, the homogeneous mixture separates into two layers, the upper water layer (saturated with phenol) and the lower phenol phase. After further cooling to 5°C and centrifuging three fractions are obtained. The upper water phase contains the protein-free bacterial LPS and nucleic acids. The use of bacterial OM in this extraction rather than whole cells reduces the contamination yielding nucleic acid-free bacterial LPS.

OM were isolated from bacterial cells using a modified version of the De Pamphilis method (1971). Sodium lauroyl sarcosinate (Sarkosyl), known for its ability to selectively solubilise the cytoplasmic membrane of Gram negative bacteria (Filip et al., 1975) was used.

*Desulfovibrio* cells, grown as described in section 2.1, were harvested from batch cultures by centrifugation (5000g for 30 min). *Pseudomonas* cells were collected from agar plates (section 2.1) and after resuspension in medium C spun at 5000g for 30 min. All subsequent procedures for LPS extraction were identical for both organisms. Pelleted cells from 600 ml cultures of *D. desulfuricans* or from 20 plates of *P. fluorescens* were washed in cold 50mM Mops buffer pH 7.4 (see Appendix) by vortexing and spinning for 30 min at 5000g. The pellet was resuspended in 20 ml Mops buffer and sonicated in an MSE Soniprep 150 for 15 x 1 min bursts at 16  $\mu$ m amplitude with 30 sec intervals. Unbroken cells and remaining debris were removed by centrifugation at 5000g for 15 min. The supernatant was incubated with 20% w/v Sarkosyl (1 ml of Sarkosyl per 10 ml of supernatant) at room temperature for 30 min with occasional agitation. The mixture was centrifuged at 35000g for 30 min and the pellet containing unsolubilised OM collected, resuspended in Mops buffer and washed as described above. The final pellet was resuspended in 50 ml of distilled water at 65-68°C. Fifty ml of 90% aqueous phenol w/v, preheated to 65-68°C was added to the suspension with vigourous stirring. After 10 mins incubation, the mixture was removed from the water bath and cooled to 10°C on ice.

The mixture, of creamy appearance, was centrifuged at 1000g for 30-45 min to obtain three layer partition. The water phase containing bacterial LPS (upper layer) was collected by careful pipetting. The remaining phenol layer and insoluble residue were treated with another 50 ml of water at 65-68°C as described above. The combined water extracts were dialysed for 3-4 days at 4°C against distilled water (minimum 5 water changes) to remove phenol. The dialysed solution was frozen in liquid nitrogen and freeze dried for 16h. The final product, a white fluffy powder, was stored at -70°C for further processing

(production of polyclonal antibodies and chemical analysis). The extraction was repeated several times to obtain a minimum of 20 mg of lyophilised LPS from each bacterial species.

### 2.7.2 HYDROLYSIS OF LPS

Lyophilised preparations of LPS extracted from the outer membranes of bacterial cells as described in section 2.7.1 were split into lipid A and polysaccharides following the method of Kumeda et al. (1989).

The LPS samples were hydrolysed with 5% v/v acetic acid at 100°C for 7.5h. The resulting insoluble material was removed by centrifuging for 10 min at 15000g, washed three times with ddH<sub>2</sub>O and lyophilised to obtain lipid A. The supernatant and the first washings were combined and freeze dried yielding free polysaccharide. The dry weights of lyophilised lipid A and polysaccharides were recorded.

### 2.7.3 EXTRACTION AND METHYLATION OF FATTY ACIDS FROM LIPID A FRACTION OF LPS

Lyophilised fractions of lipid A (4 mg from *P. fluorescens* and 1.5 mg from *D. desulfuricans*), (section 2.7.2.2), were transferred to acid washed 10 ml test tubes with teflon-lined screw caps. Two ml of 5% NaOH in 50% methanol were added to each sample and the tubes were kept at 100°C for 5 min on a heating block. The mixtures were vortexed for 30 sec. and heated at 100°C for an additional 25 min. The solutions were neutralised with 6N HCl and the fatty acids (FA) were extracted from the aqueous phase with hexane. A small amount of sodium sulphate (anhydrous) was added to remove water. The liquid phase was drawn off by pipette and evaporated under a stream of N<sub>2</sub>. The FA were methylated in 2 ml of boron trifluoride (BF<sub>3</sub>) methylation reagent (Supelco) by heating at 80°C for 20 min. The mixtures were cooled to room temperature and 10 ml of hexane followed by 10 ml ddH<sub>2</sub>O were added to each sample. The suspensions were vortexed and the phases allowed to separate. The upper organic phase was removed and washed again with 10 ml of ddH<sub>2</sub>O. The organic layer was then collected and evaporated under a stream of N<sub>2</sub>.

#### **2.7.4 IDENTIFICATION OF LPS-FA BY GC-MS**

The FA residues were resuspended in 0.3 ml of hexane and injected into GC-MS under conditions described previously in section 2.6.3.6. The peaks were identified against a library of bacterial FA profiles. The library was created in the laboratory of Professor Geesey at the California State University in Long Beach.

#### **2.7.5 DETERMINATION OF CARBOHYDRATES IN LPS SAMPLES**

Polysaccharides from LPS samples (section 2.7.2) were prepared for sugar identification as described for free EPS and biofilm samples (section 2.6.3). The characterisation of carbohydrates was accomplished by employing GC-MS and quantitative data was acquired by using GC-FID, as described in sections 2.6.3.5-2.6.3.7.

Colorimetric assays for neutral hexose content and for N-acetyl-2aminosugar content were performed prior to chromatographic analysis. Determination of neutral hexoses in LPS samples followed the method of Dubois et al. (1956) as described in section 2.6.2.

The presence of N-acetyl-2aminosugars in LPS samples was detected following the procedure of Elson-Morgan(1939) as described by Chaplin and Kennedy (1986).

Crude LPS samples (1mg) were dissolved in ddH<sub>2</sub>O (1 ml). The samples (250 µl) were added to 50 µl of di-potassium tetraborate tetrahydrate solution (6.1% w/v of di-potassium tetraborate tetrahydrate in ddH<sub>2</sub>O). The samples were heated at 100°C for 3 min and then cooled rapidly in an ice box to room temperature. A solution of benzaldehyde in acetic acid (1.5 ml) was added to each sample. Care was taken to wash down any condensate formed on the tube walls. The benzaldehyde solution was prepared as follows: 11 ml of concentrated HCl was added to 1.5 ml of ddH<sub>2</sub>O. A further 87.5 ml of glacial acetic acid was added and 10g of 4-(N,N dimethylamino)-benzaldehyde was dissolved in this mixture. 10 ml of this solution was diluted to 100 ml with glacial acetic acid immediately prior to use. The samples were incubated at 37°C for 20 min. The absorbance was

determined at 585 nm after cooling samples to room temperature. The calibration curve was obtained using 2 acetamido-2 deoxy-D-glucose as the standard.

#### **2.7.6 GEL ELECTROPHORESIS OF LPS**

LPS samples were subjected to SDS-PAGE gel electrophoresis as described in section 2.6.4.2. LPS on the gel were detected by the silver stain method of Wray et al. (1981). The gel was soaked in 50% reagent grade methanol for 4 hours. It was then stained for 15 min with constant gentle agitation and washed in ddH<sub>2</sub>O for 5 min. The staining solution was prepared as follows: 0.8 g silver nitrate in 4 ml of distilled H<sub>2</sub>O was added dropwise into a solution of 21 ml of 0.36% Na<sub>2</sub>OH and 1.4 ml of 14.8M NH<sub>4</sub>OH with constant stirring. The volume of the solution was increased to 100 ml with ddH<sub>2</sub>O. The gel was developed by soaking in a freshly prepared solution of 2.5 ml of 1% citric acid and 0.25 ml of 38% formaldehyde in 497.25 ml ddH<sub>2</sub>O until bands were visible (approx 10-15 min). After washing in ddH<sub>2</sub>O the gel was transferred to 50% methanol to stop the development process and stored in this solution until a photograph was taken.

##### **2.7.6.1 Detection of carbohydrates in LPS gels**

Carbohydrates in SDS-PAGE gels were detected by the method of Racusen (1979). LPS gels were washed twice with constant agitation in a mixture of 25% v/v isopropanol, 10% v/v acetic acid and dH<sub>2</sub>O for a total of 8 hours (4 hours for each wash). A third wash was performed in the same solvent mixture containing 0.2% w/v thymol. Gels were drained and transferred to a mixture of 60% v/v sulphuric acid and 10% ethanol at room temperature. Gels were kept in this solution at 35°C for 2.5h with gentle shaking. As soon as red coloured zones indicating presence of carbohydrates were well defined, gels were removed from the acid solution and photographed.

## **2.8 CORROSION STUDIES**

Mild and stainless steel surfaces exposed to bacterial cultures for various lengths of time were examined for corrosion by observing the surfaces under a Scanning Electron

Microscope, by performing Energy Dispersive X-ray analysis and by conducting potentiostatic measurements.

#### 2.8.1 SEM OBSERVATIONS OF CORROSION ON MS AND SS SURFACES

MS and SS stubs, similar to those used as working electrodes in polarisation measurements, incubated with bacterial cultures (section 2.5.2) were examined for corrosion occurring beneath the biofilm formed on their surfaces. After examination under the SEM for biofilm formation (section 2.5.5), electrodes were treated with a passivating Clark's solution (2%w/v  $S_6O_2O_3$  and 5.9% w/v of  $SnCl_2$  in 35% HCl) to remove deposits from their surfaces. Cleaned electrodes were examined directly under SEM (no fixation or gold coating were required) as described in section 2.5.5.

#### 2.8.2 ENERGY DISPERSIVE X-RAY ANALYSIS (EDAX) OF CORROSION PRODUCTS PRESENT ON MS AND SS ELECTRODES

MS and SS stubs incubated with bacteria for 7,16 and 21 days as described in section 2.4.2 were removed from universal bottles with forceps, care being taken to preserve the film present on the exposed stub surfaces, and dried on filter paper with a hot air gun. Dried samples were fixed on to an aluminium stage (4 samples per stage) with quick drying silver paint to provide electrical contact and subjected to SEM observation using a Super Mini SEM (International Scientific Instruments) equipped with an energy-dispersive X-ray analyser (Lewell Electronics Ltd., UK) and Princeton Gamma-tech system 4 computer. The samples were scanned at an acceleration voltage of 15kV and a magnification of x100. The beam current used for the X-ray analysis was adjusted to 5 nAmps. and the distance between the surface of the sample and the detector was set to 23 nm. The X-ray spectrum was collected for 100 secs. for each sample. The entire experiment was repeated twice for each incubation period.

## 2.8.3 POLARISATION MEASUREMENTS

### 2.8.3.1 Sample preparation for polarisation studies

Copper wires, 6 cm long and 1.5 mm in diameter were welded to the MS and SS stubs (one wire per stub). The stubs were manufactured as described in section 2.4.1. The wires were then enclosed in adhesive, heat shrink sleeving. The wire free surfaces of the stubs were left exposed to allow the build up of biofilms. All the other surfaces were covered with a layer of lacomit varnish to insulate these areas and to make the samples watertight except for the exposed surface. The stubs were then placed in a laminar flow cabinet and exposed to UV light for a period of 72 hours (rotated after 36 h) to sterilise the stubs. Samples were then inserted aseptically into universal bottles containing sterile medium C (Postgate, 1984). The bottles with the stubs were inoculated with pure and mixed cultures of *D. desulfuricans* and *P. fluorescens* ( $10^5$  cells / ml) as described in section 2.4.2, and incubated for 7, 16, and 21 days at 30°C. Controls consisted of MS and SS stubs in uninoculated medium C.

### 2.8.3.2 Potentiostatic Measurements

Amperometric experiments were carried out in an electrochemical cell (Figure 6)

The auxiliary electrode consisted of 1cm x 2.5cm platinum sheet welded to a platinum wire lead. The wire was protected by a 3 mm diameter glass tube which also provided positional stability of the auxiliary electrode. The saturated calomel reference electrode (Russel type CRL) was mounted in a glass tube filled with a saturated potassium chloride agar. The end of the tube was drawn out to a fine point, slightly curved, to maintain a constant distance between the test and reference electrodes. The exposed surfaces of MS and SS stubs provided test electrodes (working electrodes).

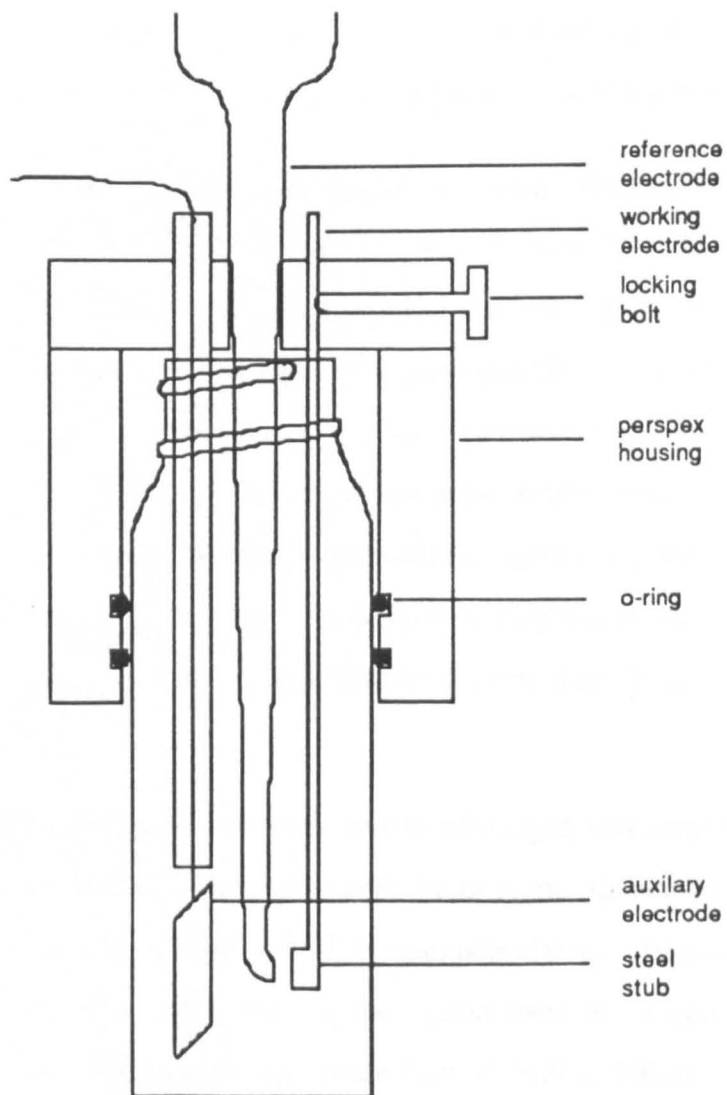

Fig. 6: Schematic representation of an electrochemical cell.



Polarisation curves were obtained by immersing the auxiliary and reference electrodes in the universal bottle containing the bacterial culture under test. The bottles were opened and the working electrodes were gently lifted by gripping the copper wire enclosed in insulating sleeving. Part of the adhesive heat shrink sleeving was removed with a surgical scalpel exposing enough of the copper wire to provide the electrical contact to the electrode.

Care was taken not to remove the stub from the incubating medium during the removal of the sleeving. All these procedures were performed aseptically. The electrodes were mounted inside a perspex housing (Figure 6) which was supported by clamps attached to a retort stand. The rubber "O" rings inside the housing provided a firm hold for the universal bottles. The working electrode was held in position by a bolt. Electrical connection to this electrode was made using a screened copper cable connected to this bolt. The distances between all three electrodes remained unchanged throughout the measurements, as their position was determined by the holes in the perspex housing that accommodated them. The electrodes were connected to a software controlled potentiostat (Sycopel; UK Thompson Electrochemical Ltd.)

The culture under measurement, with electrodes submerged, was purged for 10 min with nitrogen gas to remove the oxygen present in the medium. Electrodes were allowed to equilibrate for 10 min and the open circuit (resting) potential was measured. This potential was then taken as the starting point for the measurement of the anodic and cathodic polarisation curves. The potential was swept from -300mV to 700mV in steps of 50mV every minute and the current measured. The direction of the potential movement from the open circuit potential determined the type of polarisation (anodic "+", or cathodic "-"). After measuring the polarisation curve in the culture medium, the electrodes were immersed in sterile, dilute saline solution. The pH of the solution was adjusted to 7.06 with 1N NaOH. The polarisation measurements in this solution were repeated to establish the effect of the incubation medium on the working electrode and to distinguish this from the effect of the biofilm formed on the surface of the electrode. The pH readings of the incubation media were taken prior to polarisation measurements. On two occasions the biofilm

formed on working electrodes was removed (after the polarisation measurements were performed) by drying the surface of the stub under a stream of nitrogen and polishing the surface with a fine grade sand paper. The electrode was then reintroduced to its culture medium and the polarisation curve was remeasured. The acquired data were processed by using the software system of the computer controlled potentiostat. The experiments were performed in the laboratory of Dr. Edyvean in the University of Leeds. The polarisation curves were drawn by the software controlled plotter.

## **CHAPTER THREE**

### **RESULTS**

### 3.1 MORPHOLOGY AND GROWTH OF *P. FLUORESCENS* AND *D. DESULFURICANS*

*P. fluorescens* grown on nutrient agar or in medium C in batch cultures releases a green pigment into the medium. The colour of the pigment can change to violet when cells are grown without subculturing for long periods of time (up to 3 months). No macroscopically visible precipitate forms on the steel surfaces. Plate 1 shows a TEM micrograph of the rod like-shape of *Pseudomonas* cells.

Cultures of *D. desulfuricans* grown in medium C appear black. After 24h of incubation, a black granular precipitate of ferrous sulphide forms at the base of the culture vessels. When stainless or mild steel surfaces are included the morphology of the deposit changes, becoming mucoidal in appearance and accumulating as a film mainly on these surfaces. The film apparently attaches more firmly to the surface of mild than to stainless steel. The shear forces applied by gentle agitation of the cultures removes the film from the surface of stainless steel (SS), but not from the mild steel (MS). The cultures of *Desulfovibrio* grown in the presence of *Pseudomonas* appear a homogeneous dull black and maintain this appearance for several months (up to 7 months), whereas pure cultures of *Desulfovibrio* usually become clear with the black deposit separated from the bulk medium after up to 2 months. The precipitation of FeS in mixed cultures seems to be reduced in comparison with pure *Desulfovibrio* cultures and the deposit is mucoidal. There is less film apparent on surfaces of mild and stainless steel in mixed cultures compared with pure *Desulfovibrio* cultures. Examined by TEM *D. desulfuricans* cells appear uniformly vibroid in shape (Plate 2).

**Plates 1 and 2**

**TEM micrographs of negatively stained *P. fluorescens* cells (Plate 1) and *D. desulfuricans* cells (Plate 2).**

Pl.1



Pl.2

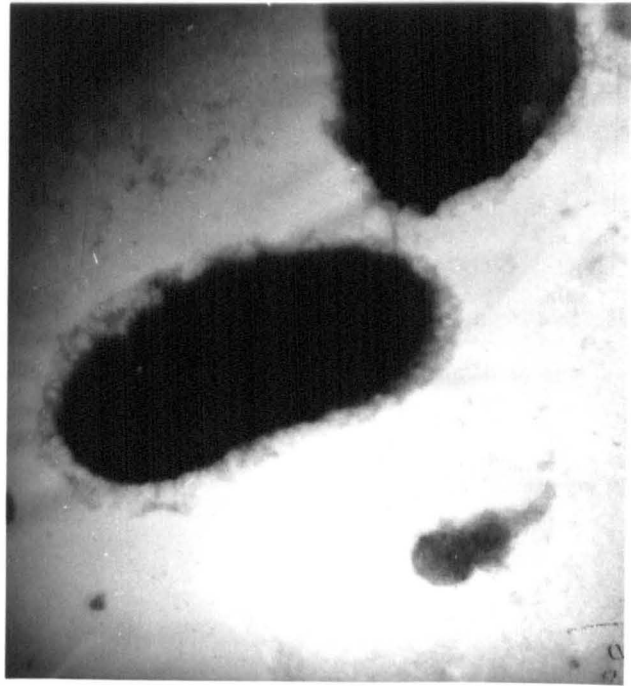

### 3.1.1 VIABLE CELL COUNT

Table 1 shows the results of the viable count performed on sessile and planktonic bacteria as presented by Moreno et al. (1990).

**Table 1: CONCENTRATION OF SESSILE AND PLANKTONIC CELLS IN PURE AND MIXED BACTERIAL CULTURES AFTER 28 DAYS OF INCUBATION IN MEDIUM C WITH MS COUPONS.**

Concentration of cells (mean value) $\pm$ SD				
	Pure cultures		Mixed cultures	
	<i>Pseudomonas</i>	<i>Desulfovibrio</i>	<i>Pseudomonas</i>	<i>Desulfovibrio</i>
sessile (log/cm <sup>2</sup> )	2.67 $\pm$ 1.05	4.33 $\pm$ 1.05	1.69 $\pm$ 1.64	4.21 $\pm$ 1.14
planktonic (log/ml)	6.23 $\pm$ 0.33	5.30 $\pm$ 0.51	4.97 $\pm$ 0.63	4.44 $\pm$ 1.07

The concentration of *P. fluorescens* cells in the biofilm decreases in mixed cultures, whereas that of *D. desulfuricans* remains unchanged. The numbers of cells of both species decrease in mixed cultures compared with the pure cultures in the planktonic phase. The planktonic cell concentration of either species in the presence of MS or SS coupons is similar to the concentration reached in coupon-free cultures (data not shown).

### 3.2 THE ATTACHMENT OF BACTERIA TO STEEL SURFACES

The experiments investigating the mechanisms involved in early adhesion of *P. fluorescens* and *D. desulfuricans* cells to steel surfaces in medium C were conducted as described in section 2.4.

#### 3.2.1 THE ATTACHMENT OF BACTERIA TO MS AND SS SURFACES IN MEDIUM C AND IN WATER

The results of adhesion studies of *Pseudomonas* and *Desulfovibrio* to MS and SS surfaces in medium C are presented in Table 2.

**Table 2: ADHESION OF *P. FLUORESCENS* AND *D. DESULFURICANS* TO MILD AND STAINLESS STEEL SURFACES IN MEDIUM C.**

Organism	Surface type	Incubation time in hours	Inoculum level cells/ml	Mean cell number per surface area (0.03mm <sup>2</sup> ) ± SD
<i>P. fluorescens</i>	MS	1	10 <sup>5</sup>	50.25 ± 7.04
	SS			23.15 ± 3.97
	MS	1.5		52.80 ± 5.02
	SS			27.10 ± 4.35
<i>D. desulfuricans</i>	MS	1	8 x 10 <sup>5</sup>	37.60 ± 5.02
	SS			11.80 ± 1.30
	MS	1		54.20 ± 7.69
	SS			13.70 ± 3.01
	MS	3		57.40 ± 9.81
	SS			14.40 ± 2.50

The number of cells of *Pseudomonas* attaching to the surface of the mild steel and to the stainless steel after periods of time between 1 and 3 hours is significantly greater than that of *Desulfovibrio* in all experiments. There is no significant increase in adhesion of either *D. desulfuricans* or *P. fluorescens* to either mild steel or stainless steel with increased



incubation time from 1 to 3 hours. The attachment of both types of bacteria to mild steel surfaces is significantly higher than that to stainless steel under all experimental conditions.

The adhesion of *Desulfovibrio* cells to MS and to SS surfaces in medium C after 1h of incubation reaches 37.6 and 11.8 cells/0.03 mm<sup>2</sup> respectively and is not significantly different from the attachment of cells to these surfaces in distilled H<sub>2</sub>O (36.1 and 10.13 cells/0.03 mm<sup>2</sup> respectively).

### 3.2.2 THE INFLUENCE OF LECTINS AND THEIR SUGAR INHIBITORS ON BACTERIAL ADHESION

Tables 3, 4 and 5 show the effects of lectins plus sugars on the adhesion to mild steel of *P. fluorescens* and *D. desulfuricans*. Lectin and sugar treatment was performed as described in sections 2.4.3 and 2.4.4.

**Table 3: EFFECT OF LECTINS ON THE ADHESION OF *P. FLUORESCENS* TO MILD STEEL. INITIAL CELL CONCENTRATION 10<sup>5</sup> cells/ml.**

Treatment*	Mean no. of cells/ 0.03 mm <sup>2</sup> ± SD	Statistical significance
Control	50.33 ± 5.37	-
ConA	34.8 ± 8.89	p < 0.05
WGA	36.2 ± 13.3	p < 0.05

\*ConA, concanavalin A; WGA, wheat germ agglutinin

**Table 4: EFFECTS OF LECTINS AND LECTINS PLUS SUGARS ON THE ADHESION OF *P. FLUORESCENS* TO MILD STEEL**

Concentration (cells/ml)	Treatment*	Mean no. of cells/ 0.03 mm <sup>2</sup> ± SD	Statistical significance
10 <sup>5</sup>	Control	50.10 ± 11.44	-
	ConA	30.60 ± 5.68	p < 0.05
	ConA + man	30.52 ± 9.66	p < 0.05
	ConA + suc	30.50 ± 6.13	p < 0.05
	ConA + glc	47.86 ± 15.75	p > 0.05
	ConA + glcNAc	47.06 ± 8.87	p > 0.05
5 x 10 <sup>5</sup>	Control	60.60 ± 10.59	-
	WGA	36.59 ± 8.91	p < 0.05
	WGA + glcNAc	57.42 ± 11.27	p > 0.05

\* Sugar concentrations: mannose (man), 313 µg/ml; sucrose (suc), 2500 µg/ml; glucose (glc), 2500 µg/ml; N-acetyl glucosamine (glcNAc), 625 µg/ml. ConA, concanavalin A; WGA, wheat germ agglutinin

**Table 5: EFFECTS OF LECTINS AND LECTINS PLUS SUGARS ON THE ADHESION OF *D. DESULFURICANS* TO MILD STEEL**

Concentration (cells/ml)	Treatment*	Mean no. of cells/ 0.03 mm <sup>2</sup> ± SD	Statistical significance
10 <sup>5</sup>	Control	40.13 ± 5.85	-
	ConA	28.00 ± 5.55	p < 0.05
	ConA + glc	28.00 ± 5.44	p < 0.05
	ConA + chit	36.90 ± 5.66	p > 0.05
	WGA	27.44 ± 5.02	p < 0.05
	WGA + chit	39.40 ± 5.59	p > 0.05
8 x 10 <sup>6</sup>	Control	82.40 ± 9.87	-
	ConA	62.40 ± 4.72	p < 0.05
	ConA + man	58.80 ± 4.81	p < 0.05
	ConA + glcNAc	52.80 ± 7.87	p < 0.05

\* Sugar concentrations: mannose (man), 939 µg/ml; glucose (glc), 2500 µg/ml; N-acetyl glucosamine (glcNAc), 625 µg/ml; chitbiose (chit), 212 µg/ml. ConA, concanavalin A; WGA, wheat germ agglutinin

Lectins ConA and WGA significantly inhibit the adhesion of *Desulfovibrio* and *Pseudomonas* to mild steel stubs compared with lectin-free controls.

Sugar inhibitors of lectins, man, glc, glcNAc and suc, specific to ConA, and glcNAc and its disaccharide form chit, specific to WGA, show different abilities in reversing WGA and ConA-inhibition of bacterial adhesion to mild steel.

The inhibition of adhesion of *Pseudomonas fluorescens* induced by ConA is reversed in the presence of glc and glcNAc. Man and suc have no significant effect on attachment of ConA-treated cells. The inhibition of adhesion caused by WGA is reversed by glcNAc. The attachment of cells of *Desulfovibrio desulfuricans* treated with ConA and WGA is not influenced by man, suc, glc or glcNAc. All these sugars fail to counteract the inhibition of attachment of *Desulfovibrio* cells caused by the lectins. Only chit, a disaccharide form of glcNAc, reverses the inhibition of adhesion brought about by the lectins.

### 3.2.3 THE EFFECT OF ENZYMES ON BACTERIAL ATTACHMENT TO MS SURFACES

The effect of treating the cells with enzymes (section 2.4.5) are shown in Tables 6 and 7.

**Table 6: INFLUENCE OF GLUCOSIDASE AND N-ACETYL GLUCOSAMINIDASE ON ADHESION OF *PSEUDOMONAS FLUORESCENS* AND *DESULFOVIBRIO DESULFURICANS* TO MILD STEEL.**

Species (cells/ml)	Treatment*	Mean no. of cells/ 0.03 mm <sup>2</sup> ± SD	Statistical significance	
<i>Pseudomonas fluorescens</i> (10 <sup>5</sup> )	Control	52.23 ± 9.0	-	
	Glucosidase 2 u/ml	10 u/ml	43.00 ± 11.69	p < 0.05
		18 u/ml	41.86 ± 10.23	p < 0.05
		35.55 ± 11.48	p < 0.05	
	glcNAC-ase	0.1 u/ml	43.80 ± 12.9	p < 0.05
		0.5 u/ml	32.80 ± 10.12	p < 0.05
0.9 u/ml		25.85 ± 6.43	p < 0.05	
<i>Desulfovibrio desulfuricans</i> (8 x 10 <sup>5</sup> )	Control	53.90 ± 7.63	-	
	Glucosidase 18 u/ml	49.20 ± 6.92	p > 0.05	
	glcNAC-ase 0.5 u/ml	37.86 ± 9.60	p < 0.05	

\*glcNAC, N-acetyl glucosamine

The enzymes glucosidase and N-acetyl-glucosaminidase significantly reduce the adhesion of *Pseudomonas* to mild steel surfaces. However, N-acetyl-glucosaminidase proves to be more potent an inhibitor than glucosidase. 0.9 u/ml N-acetyl-glucosaminidase is able to reduce the adhesion of *P. fluorescens* cells to mild steel to 49% compared to controls, whereas twice this concentration of glucosidase (2 u/ml) reduces the attachment to only 82%. It requires 18 u/ml glucosidase to reduce adhesion of cells to 68%.

Cells of *D. desulfuricans* show no sensitivity to glucosidase treatment in their attachment ability. Concentrations of glucosidase up to 18 u/ml have no significant effect on adhesion of cells compared with controls. In contrast, as little as 0.5 u/ml N-acetyl-glucosaminidase is capable of reducing adhesion of *Desulfovibrio* to mild steel surfaces to between 60% and 70% compared with untreated cells.

**Table 7:** EFFECT OF PRONASE AND PRONASE PLUS LECTIN TREATMENT ON ADHESION OF *PSEUDOMONAS FLUORESCENS* AND *DESULFOVIBRIO DESULFURICANS* TO MILD STEEL. INITIAL CELL CONCENTRATIONS  $10^5$  /ml

Species	Treatment*	Mean no. of cells/ 0.03 mm <sup>2</sup> ± SD	Statistical significance
<i>P. fluorescens</i>	Control	50.33 ± 5.37	-
	Pronase	50.66 ± 4.82	p > 0.05
	Pronase + WGA	38.60 ± 5.62	p < 0.05
	WGA	36.20 ± 13.3	p < 0.05
	Pronase + ConA	37.26 ± 7.13	p < 0.05
	ConA	34.80 ± 8.89	p < 0.05
<i>D. desulfuricans</i>	Control	42.22 ± 5.68	-
	Pronase	41.20 ± 5.31	p > 0.05
	Pronase + WGA	29.60 ± 3.77	p < 0.05
	WGA	27.44 ± 5.02	p < 0.05

\*Pronase concentration 200 µg/ml.

WGA, wheat germ agglutinin; ConA, concanavalin A.

The attachment of both species of bacteria to mild steel surfaces remains unchanged when cells are subjected to 200 µg/ml protease treatment for 1h. However, when protease-treated cells are also treated with ConA and WGA there is a significant reduction in adhesion to mild steel compared with untreated and protease only treated controls.

#### 3.2.4 SLIDE AGGLUTINATION TESTS FOR ANTIBODY SPECIFICITY

The antibodies produced against LPS of *D. desulfuricans* and *D. vulgaris* (section 2.3) cause agglutination of cells of *D. desulfuricans* and have no effect on *P. fluorescens* cells. The preimmune rabbit serum (PRS) purified by the same method fails to agglutinate these cells.

The agglutination of *P. fluorescens* cells occurs when exposed to homologous antiserum but it is visible only under the light microscope. PRS does not cause agglutination of these bacteria. Cells of *D. desulfuricans* are not agglutinated by antibodies against *P. fluorescens* LPS.

#### 3.2.5 THE EFFECT OF ANTIBODIES RAISED AGAINST BACTERIAL LPS ON ATTACHMENT OF CELLS TO MS SURFACES.

Antibodies raised against LPS extracted from bacterial OM as described in section 2.7.1 are able to influence attachment of their homologous cells to mild steel surfaces as can be seen from Tables 8 and 9.

**Table 8: ADHESION OF *DESULFOVIBRIO DESULFURICANS* TO MILD STEEL SURFACES WITHIN 1 HOUR, WITH AND WITHOUT PREINCUBATION OF CELLS WITH SPECIFIC ANTIBODIES.**

Preincubation time (hours)	Concentration (cells/ml)	Treatment (400 µg/ml serum protein)	Mean no. of cells/0.03 mm <sup>2</sup> ± SD	Statistical significance
1.0	8 x 10 <sup>4</sup>	Medium C	33.30 ± 6.7	NS p < 0.05 p < 0.05
		R-Serum	31.06 ± 4.74	
		A-LPS <sub>DD</sub>	25.60 ± 7.20	
		A-LPS <sub>DV</sub>	23.54 ± 4.78	
4.5	8 x 10 <sup>4</sup>	Medium C	36.90 ± 4.03	NS p < 0.05 p < 0.05
		R-Serum	34.60 ± 4.74	
		A-LPS <sub>DD</sub>	20.20 ± 3.55	
		A-LPS <sub>DV</sub>	19.10 ± 3.81	
1.5	8 x 10 <sup>5</sup>	Medium C	48.05 ± 7.83	NS NS p < 0.05 p < 0.05
		R-Serum	50.70 ± 12.4	
		A-LPS <sub>PF</sub>	49.90 ± 5.98	
		A-LPS <sub>DD</sub>	33.40 ± 8.9	
		A-LPS <sub>DV</sub>	31.40 ± 8.21	

NS - not significant

The attachment of cells of *D. desulfuricans* treated with 400 µg/ml antibodies raised against LPS of *D. desulfuricans* (A-LPS<sub>DD</sub>) or of *D. vulgaris* (A-LPS<sub>DV</sub>) is significantly reduced compared with control untreated and preimmune rabbit serum (PRS) treated cells. There is no significant difference in the attachment of untreated and PRS treated cells. The attachment of *D. desulfuricans* treated with antibodies raised against the LPS of *P. fluorescens* is not significantly different to that of the controls.

The attachment of antibody-treated *D. desulfuricans* cells decreases when incubation time with antibody is prolonged to 4.5h.

**Table 9: ADHESION OF *PSEUDOMONAS FLUORESCENS* TO MILD STEEL SURFACES WITHIN 1 HOUR, WITH AND WITHOUT PREINCUBATION OF CELLS WITH SPECIFIC ANTIBODIES.**

Preincubation time (hours)	Concentration (cells/ml)	Treatment (400 mg/ml serum protein)	Mean no. of cells/0.03 mm <sup>2</sup> ± SD	Statistical significance
1.5	10 <sup>5</sup>	Medium C	50.02 ± 8.76	NS p < 0.05 NS NS
		PRS	50.12 ± 6.88	
		A-LPS <sub>PF</sub>	29.00 ± 4.37	
		A-LPS <sub>DD</sub>	49.70 ± 8.2	
		A-LPS <sub>DV</sub>	50.70 ± 7.02	
4.5	10 <sup>5</sup>	Medium C	48.70 ± 8.93	NS
		PRS	48.70 ± 6.75	NS
		A-LPS <sub>PF</sub>	28.14 ± 4.48	p < 0.05

NS - not significant

The adhesion of *P. fluorescens* incubated with antibodies raised against its LPS (A-LPS<sub>PF</sub>) decreases significantly compared with controls. The time of incubation with antibody seems to have no significant effect on this reduction. The treatment of *Pseudomonas* cells with PRS, A-LPS<sub>DD</sub> and A-LPS<sub>DV</sub> does not affect their adhesion ability to mild steel.

### 3.3 ANALYSIS OF LPS EXTRACTED FROM BACTERIA

LPS extracted from the OM of *P. fluorescens* and *D. desulfuricans* as described in section 2.7.1 were subjected to SDS - gel electrophoresis and to chemical analysis to characterise the fatty acid composition of lipid A and to identify carbohydrates present in the O-antigenic portion.

#### 3.3.1 SDS - GEL ELECTROPHORESIS OF LPS SAMPLES

Plate 3 shows an SDS gel analysis of LPS extracted from *D. desulfuricans* and *P. fluorescens*. The pink colour indicates the presence of carbohydrates.

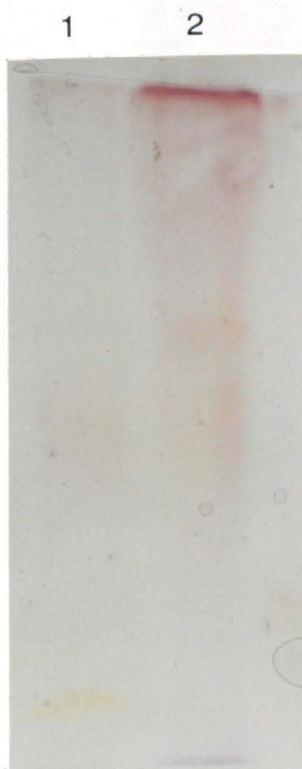

Pl. 3 SDS-gel stained to detect the presence of carbohydrates in LPS of *Desulfovibrio* (lane 1) and *Pseudomonas* (lane 2).



Plates 4a, b show SDS gels of LPS from *P. fluorescens* stained with a) silver to visualise polysaccharide and b) PAGE blue to detect protein contamination of the sample.

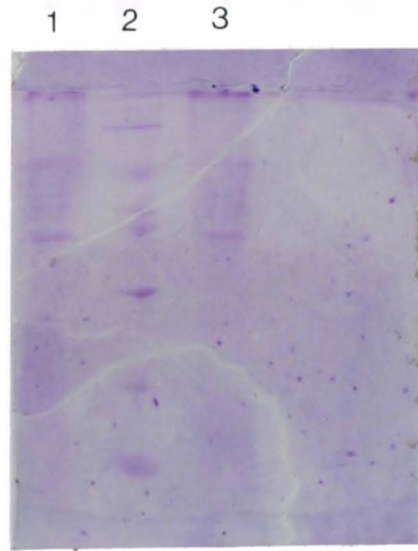

Pl. 4a SDS gel of *P. fluorescens* LPS silver stained.

Lane 1 *P. fluorescens* LPS

Lane 2 protein standards

Lane 3 *P. fluorescens* LPS

Pl. 4b SDS gel of *P. fluorescens* LPS stained with PAGE blue

Lane 1 *P. fluorescens* LPS

Lane 2 protein standards

Lane 3 *P. fluorescens* LPS

On both plates, lane 2 contains a mixture of six protein standards (Electrophoresis Calibration Kit, Pharmacia LKB). The polysaccharide portion of *P. fluorescens* LPS appears to have a homogeneous structure (Pl. 4a lanes 1 and 3). The amount of protein visualised in the LPS sample is small (Pl. 4b lanes 1 and 3).

LPS from *D. desulfuricans* show similar structure to those from *P. fluorescens* when silver stained (photograph not shown).

### 3.3.2 ANALYSIS OF FATTY ACIDS (FA) EXTRACTED FROM LIPID A OF BACTERIAL LPS.

The lyophilised LPS of *P. fluorescens* and *D. desulfuricans* when subjected to degradation as described in section 2.7.2 yielded 20% w/w and 15% w/w of lipid A respectively. The types of FA extracted from Lipid A of these bacteria are listed in Table 10. Typical GC-MS chromatograms of FA profiles are shown in Figure 7 (*P. fluorescens*) and in Figure 8 (*D. desulfuricans*).

**Table 10: FATTY ACIDS EXTRACTED FROM LIPID A OF BACTERIAL LPS**

<i>P. FLUORESCENS</i>	<i>D. DESULFURICANS</i>
(1) Hexadecanoic acid	(1) 9-Octadecanoic acid
(2) Pentadecanoic acid	(2) Tetracosenoic acid
(3) 9-Decanoic acid	(3) Heptadecenoic acid
(4) 9-Dodecenoic acid	(4) 10-Octadecenoic acid
(5) Heptadecanoic acid	(5) Eicosenoic acid
(6) 10-Octadecenoic acid	(6) 8-Octadecynoic acid
(7) 9-Octadecenoic acid	

Fatty acids of *P. fluorescens* LPS differ from those of *D. desulfuricans* except for 10-octadecenoic acid which is common for both bacteria. The probability of match between identified peaks of FA and library peaks is approximately 80%.

### 3.3.3 ANALYSIS OF CARBOHYDRATES PRESENT IN BACTERIAL LPS

The neutral hexose content detected in LPS samples by colorimetric assay was 40% w/w for *P. fluorescens* and 28% w/w for *D. desulfuricans*. The Elson-Morgan reaction showed the presence of trace amounts of aminosugars, 0.53 µg in 1 mg of LPS from *P. fluorescens* and 0.20 µg in 1 mg of LPS from *D. desulfuricans*. Types of carbohydrates identified by GC-MS and GC-FID and their quantities calculated from GC-FID data are presented in Table 11. Figures 9 and 10 show sample chromatograms of neutral carbohydrates detected by GC-FID in polysaccharides extracted from LPS of *P. fluorescens* and *D. desulfuricans* respectively.

**Fig.7 GC-MS chromatograph of FA extracted from LPS of *P.fluorescens***

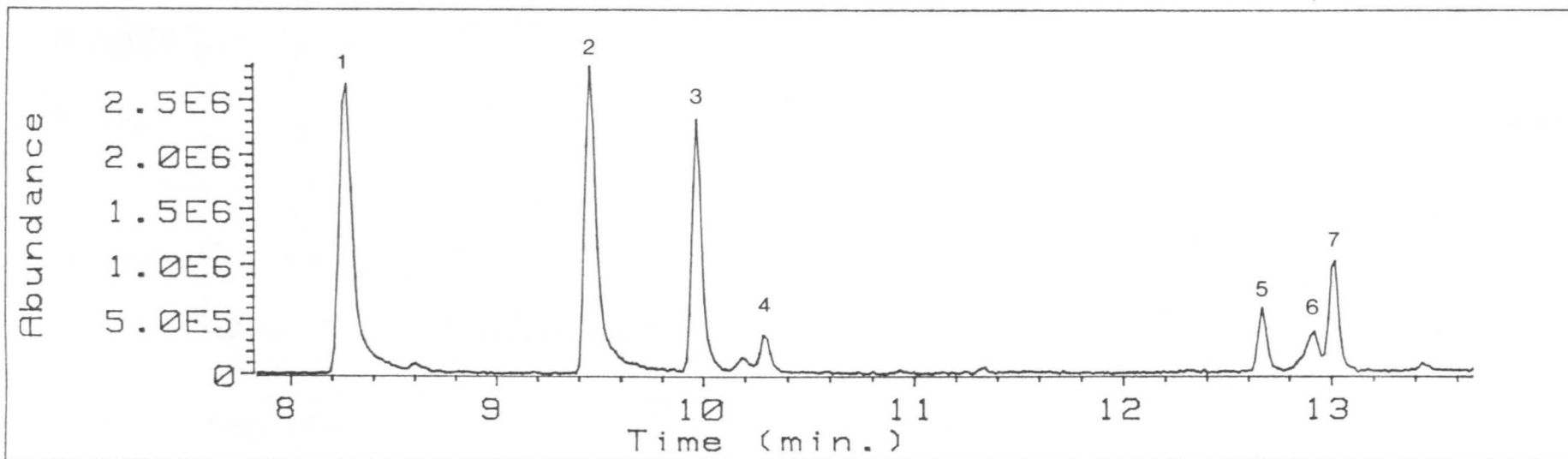

**Fig.8 GC-MS chromatograph of FA extracted from LPS of *D.desulfuricans***

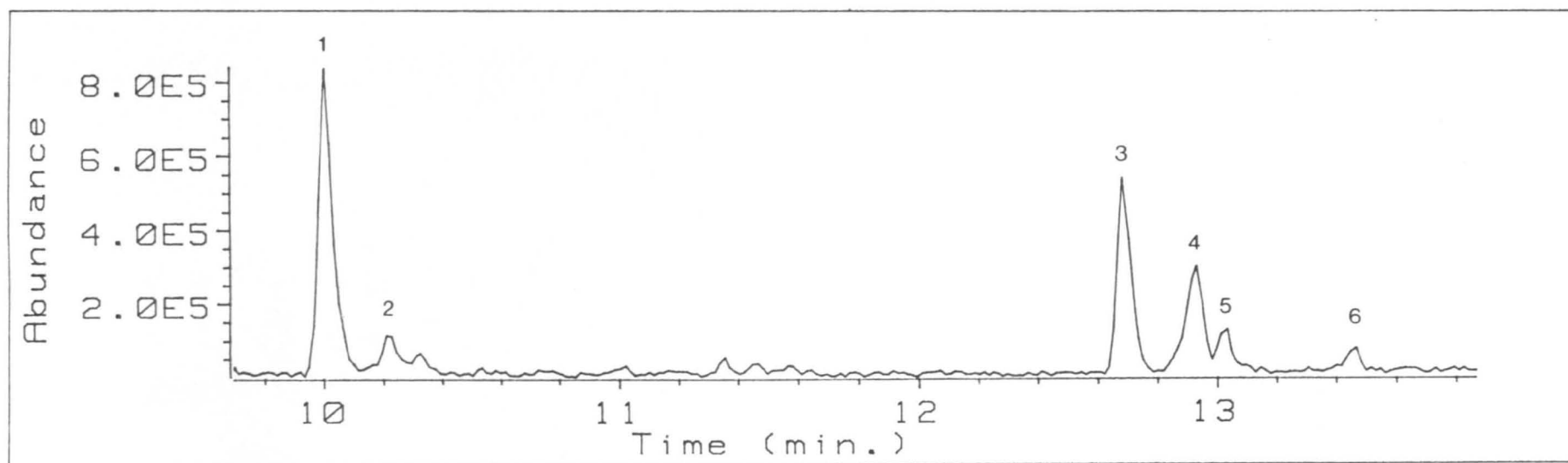
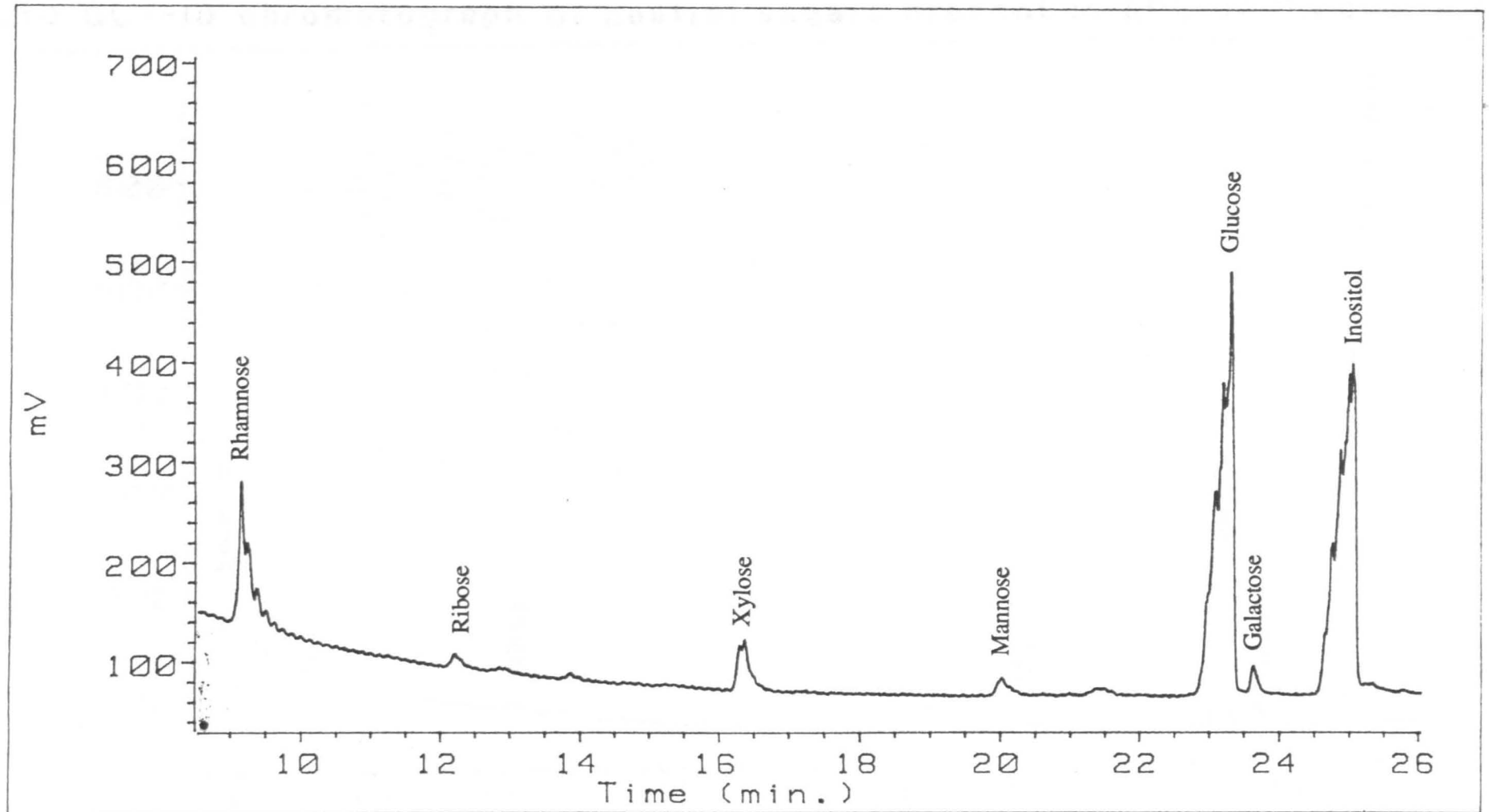
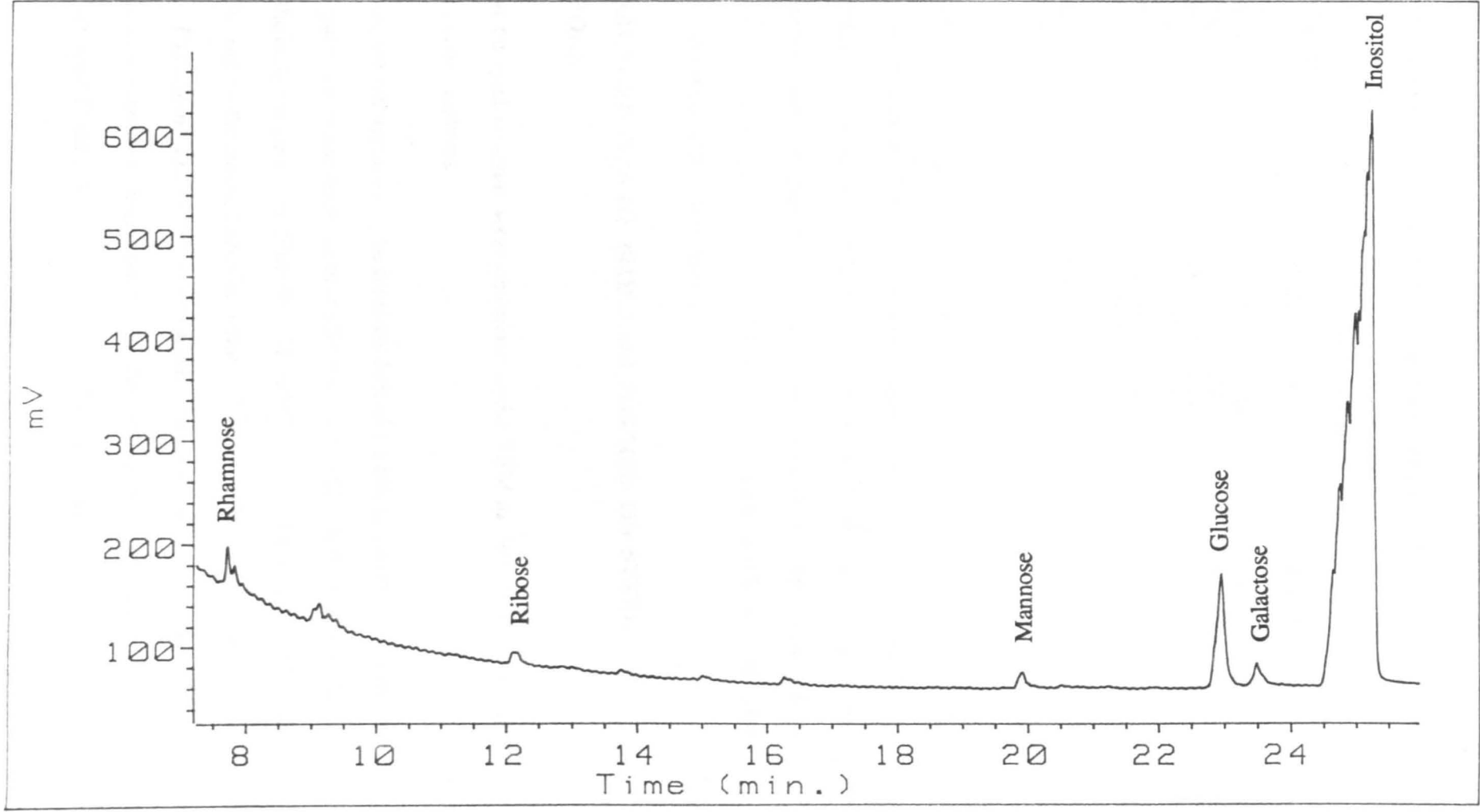

Fig.9 GC-FID chromatograph of neutral sugars present in LPS of *P.fluorescens*



**Fig.10 GC-FID chromatograph of neutral sugars present in LPS of *D.desulfuricans***



**Table 11: CARBOHYDRATE COMPOSITION OF BACTERIAL LPS**

Type of sugar	µg of carbohydrate in 1 mg of LPS ±SD	
	<i>P. fluorescens</i>	<i>D. desulfuricans</i>
Rhamnose	18.061 ± 0.320	2.791 ± 0.185
Mannose	2.443 ± 0.020	1.744 ± 0.129
Glucose	62.780 ± 0.512	11.298 ± 0.916
Galactose	2.576 ± 0.167	2.935 ± 0.337
Xylose	6.388 ± 0.120	not detected
Ribose	1.889 ± 0.376	1.426 ± 0.080
<b>TOTAL</b>	<b>94.137 ± 1.515</b>	<b>19.694 ± 1.647</b>

Polysaccharide obtained from LPS of *P. fluorescens* contains glucose (66% w/w of total neutral sugars) and rhamnose (19% w/w of total sugars) as major sugar components. Other carbohydrates such as mannose, galactose and xylose are present in small amounts. Glucose is the predominant component in the case of *D. desulfuricans* (56% w/w of total sugars). Galactose (14.5% w/w), rhamnose (14% w/w) and mannose (8% w/w) are also present. Xylose is not detectable in this sample.

### 3.4 CHARACTERISTICS OF BIOFILMS FORMED ON STEEL COUPONS

Biofilms formed on steel coupons were examined under SEM as described in section 2.5.5, prior to chemical analyses.

Plates 5 a,b,c show the micrographs of the biofilms formed on MS coupons after 7 days of incubation with pure and mixed bacteria in medium C. Abundant EPS visible as fibres extending from the cells are seen in biofilms formed on MS coupons by pure *Desulfovibrio* cultures (Plate 5b) and by the mixed bacterial cultures (Plate 5c). Biofilms developed on MS coupons by *Pseudomonas* cultures are much less voluminous and devoid of amorphous corrosion products characteristic for *Desulfovibrio* biofilms (Plate 5a). Strands of EPS are seen linking bacteria with the surface and interconnecting the cells.

Plates 5a,b,c SEM micrographs showing biofilms formed on MS coupons after 7 days of incubation in medium C with cultures of:

- a) *P. fluorescens*
- b) *D. desulfuricans*
- c) *D. desulfuricans* and *P. fluorescens*



Pl. 5a

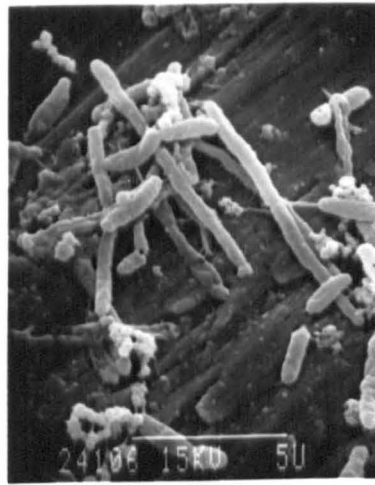

Pl. 5b

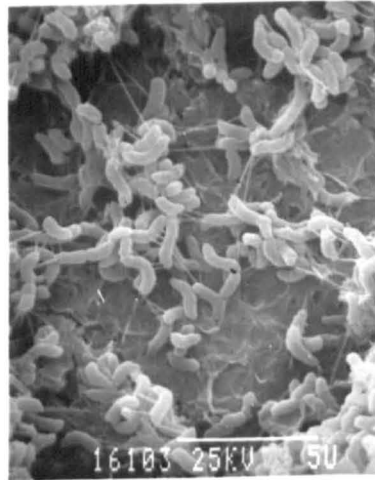

Pl. 5c

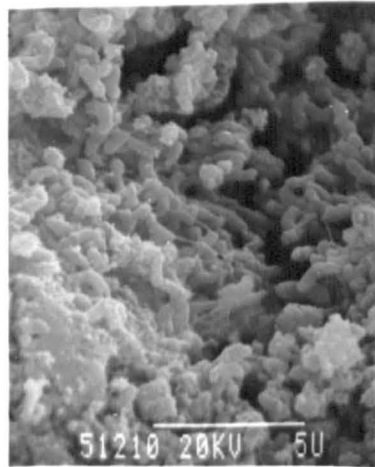

There is no great difference in morphology between 7 day old and 28 day old biofilms developed on MS coupons when studied under SEM, therefore no micrographs of the 28 day old biofilms are shown in this section. Since the biofilms observed on SS surfaces are very scanty and only few EPS fibers are visible the micrographs of these surfaces are not included in this section.

The detailed SEM studies of biofilm formation on MS and SS surfaces are carried out on steel stubs used as electrodes in polarisation experiments and are presented in section 3.6 of the results.

Table 12 shows the total dry weights of biofilms removed from MS and SS coupons.

**Table 12: DRY WEIGHT OF BIOFILMS (mg  $\pm$  SD) FORMED ON 15 MS AND 15 SS COUPONS INCUBATED FOR 7 AND 28 DAYS WITH BACTERIAL CULTURES IN MEDIUM C.**

Inoculum	7 DAY OLD BIOFILM	
	ON MS	ON SS
<i>P. fluorescens</i>	103.7 $\pm$ 13.0	7.9 $\pm$ 3.0
<i>D. desulfuricans</i>	118.7 $\pm$ 20.0	10.1 $\pm$ 1.0
<i>P. fluorescens</i> and <i>D. desulfuricans</i>	102.0 $\pm$ 20.0	7.2 $\pm$ 1.0

Inoculum	28 DAY OLD BIOFILM	
	ON MS	ON SS
<i>P. fluorescens</i>	181.1 $\pm$ 11.0	10.5 $\pm$ 1.0
<i>D. desulfuricans</i>	251.8 $\pm$ 19.0	32.2 $\pm$ 2.0
<i>P. fluorescens</i> and <i>D. desulfuricans</i>	188.9 $\pm$ 20.0	19.4 $\pm$ 8.0

There is no significant difference between dry weights of 7 day old biofilms formed by pure and mixed bacterial cultures on either MS or SS surfaces. The dry weight of 28 day old biofilms formed by pure cultures of *D. desulfuricans* is significantly greater than that formed on these surfaces by pure and mixed *Pseudomonas* cultures. This observation does not apply to biofilms grown in the presence of these bacteria on SS surfaces.

There is a significant increase in dry weight of biofilms grown on MS coupons with prolonged time of incubation from 7 to 28 days, for all types of inoculum. In the case of biofilms present on SS coupons, the significant increase in weight of biofilm with time can only be observed in pure *Desulfovibrio* cultures. The amount of biofilm recovered from SS coupons is significantly lower than the quantities obtained from MS coupons in the case of all sample types.

#### 3.4.1 CHEMICAL ANALYSES OF BIOFILMS GROWN ON STEEL COUPONS

Biofilms grown on MS and SS coupons, as described in section 2.5.2, were subjected to SDS-gel electrophoresis and analysed chemically for total neutral hexose and protein content and for the types of neutral carbohydrates present.

### 3.4.1.1 DETECTION OF CARBOHYDRATES IN SDS-GELS

SDS-gels were stained according to Racusen's method as described in section 2.7.6.1 to visualise carbohydrates present in the samples. The gels develop a characteristic pink colour indicating presence of sugar. Although the colour was readily visible prior to taking the photograph, Plate 6 does not produce the colour accurately. Arrows indicate the areas of colour development.

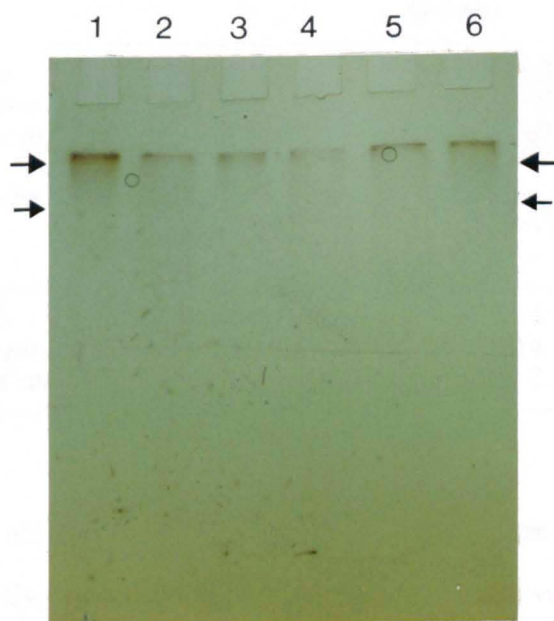

Pl. 6 SDS gel stained to demonstrate the presence of carbohydrates in biofilm samples. The amount of sample loaded was 0.08 mg per well.

- Lane 1, 7 day old biofilm formed by *P. fluorescens* on MS coupons
- Lane 2, 7 day old biofilm formed by *D. desulfuricans* on MS coupons
- Lane 3, 7 day old biofilm formed by mixed cultures on MS coupons
- Lane 4, 7 day old biofilm formed by mixed cultures on SS coupons
- Lane 5, 28 day old biofilm formed by *P. fluorescens* on MS coupons
- Lane 6, 28 day old biofilm formed by *D. desulfuricans* on MS coupons

### 3.4.1.2 Colorimetric estimation of carbohydrates present in biofilms

The results presented in Table 13 show the amount of neutral sugar detected by colorimetric assay in 1 mg dry weight of crude biofilm recovered from MS and SS coupons.

**Table 13: COLORIMETRIC ESTIMATION OF SUGAR LEVEL ( $\mu\text{g}/\text{mg} \pm \text{SD}$ ) IN BIOFILMS RECOVERED FROM 15 MS AND 15 SS COUPONS AFTER 7 AND 28 DAYS OF INCUBATION WITH BACTERIAL CULTURES .**

Inoculum	7 DAY OLD BIOFILM	
	ON MS	ON SS
<i>P. fluorescens</i>	34.7 $\pm$ 12.5	28.00 $\pm$ 8.00
<i>D. desulfuricans</i>	75.0 $\pm$ 14.9	29.90 $\pm$ 1.65
<i>P. fluorescens</i> and <i>D. desulfuricans</i>	87.7 $\pm$ 26.2	48.32 $\pm$ 11.7

Inoculum	28 DAY OLD BIOFILM	
	ON MS	ON SS
<i>P. fluorescens</i>	34.7 $\pm$ 4.40	28.90 $\pm$ 2.70
<i>D. desulfuricans</i>	63.4 $\pm$ 14.4	36.60 $\pm$ 7.60
<i>P. fluorescens</i> and <i>D. desulfuricans</i>	86.25 $\pm$ 2.50	58.30 $\pm$ 5.00

Seven and 28 day old biofilms formed on MS coupons by pure cultures of *D. desulfuricans* contain significantly more sugar compared with the respective biofilms developed on SS surfaces.

Biofilms grown on MS coupons for 28 days in mixed bacterial cultures contain significantly more sugar than those formed on SS surfaces.

Seven and 28 day old biofilms removed from MS coupons exposed to pure and mixed *Desulfovibrio* cultures contain significantly more sugar than the respective biofilms formed in pure *Pseudomonas* cultures.

With increased time of incubation more carbohydrate is detected in mixed than in pure culture biofilms on SS coupons. No other differences noted on Table 13 are statistically significant.

The quantities of sugar measured in 1 mg of 7 day old biofilm removed from MS coupons and treated to remove inorganic corrosion products are comparable to the levels detected in crude biofilm samples. There is 5.87 % (w/w) of sugars present in treated biofilms of *Desulfovibrio*, 3.42% (w/w) in *Pseudomonas* biofilms and 6.18% (w/w) in biofilms from mixed bacterial cultures. The amounts detected in the respective crude biofilms are 7.55% (w/w) 3.48% (w/w) and 8.77% (w/w).

Traces of uronic acids were detected colorimetrically in crude and treated 7 day old biofilm samples removed from MS coupons (Table 14). Biofilms removed from SS surfaces and 28 day old biofilms recovered from MS coupons were not assayed for uronic acid presence.

**Table 14: URONIC ACID CONTENT ( $\mu\text{g} / \text{mg}$ ) IN BIOFILMS RECOVERED FROM 15 MS COUPONS AFTER 7 DAYS OF INCUBATION WITH BACTERIAL CULTURES.**

Inoculum	crude biofilm	treated biofilm
<i>P. fluorescens</i>	3.743	3.040
<i>D. desulfuricans</i>	5.030	4.690
<i>P. fluorescens</i> and <i>D. desulfuricans</i>	5.890	4.980

Treatment of biofilms as previously described does not influence the efficiency of uronic acid recovery. The amount of uronic acid found in treated biofilms are similar to those detected in crude biofilms.

#### 3.4.2 CHROMATOGRAPHIC ANALYSES OF CARBOHYDRATES PRESENT IN BIOFILMS.

The results of GC-MS and GC-FID analyses of carbohydrates extracted from 7 day old biofilms formed on MS coupons by pure and mixed cultures of *P. fluorescens* and *D. desulfuricans* are summarised in Table 15.

The biofilms removed from SS coupons were not subjected to gas chromatographic analysis of sugars because of their low yield.

**Table 15: CARBOHYDRATES PRESENT IN BIOFILMS RECOVERED FROM 15 MS COUPONS ( $\mu\text{g}/\text{mg}$  OF SAMPLE  $\pm$ SD ) AFTER 7 DAYS OF INCUBATION WITH BACTERIAL CULTURES.**

Type of sugar	<i>P. fluorescens</i>	<i>D. desulfuricans</i>	<i>P. fluorescens</i> <i>D. desulfuricans</i>
Rhamnose	-	0.372 $\pm$ 0.07	-
Mannose	0.475 $\pm$ 0.009	0.630 $\pm$ 0.004	1.190 $\pm$ 0.07
Glucose	0.973 $\pm$ 0.06	0.927 $\pm$ 0.02	1.102 $\pm$ 0.059
Galactose	0.130 $\pm$ 0.02	0.602 $\pm$ 0.04	0.487 $\pm$ 0.04
Xylose	0.096 $\pm$ 0.014	0.180 $\pm$ 0.002	-
Allose	-	0.175 $\pm$ 0.037	-
Gulose	0.053 $\pm$ 0.02	-	-
Ribose	0.094 $\pm$ 0.07	0.250 $\pm$ 0.001	0.296 $\pm$ 0.02
Total	1.821 $\pm$ 0.193	3.136 $\pm$ 0.174	3.075 $\pm$ 0.198

- not detected

The content of neutral sugars in 1 mg of biofilms from pure and mixed cultures of *D. desulfuricans* is 1.7 times greater than the amount of carbohydrates in biofilm formed by pure cultures of *P. fluorescens*. Glucose and mannose are the main components of all three types of biofilms. Glucose contributes 53% (w/w) into total neutral sugars detected in biofilms from *P. fluorescens*, 29% (w/w) to *D. desulfuricans* biofilms and 36% (w/w) to biofilm from mixed populations. Mannose amounts to 26% (w/w), 20% (w/w) and 36% (w/w) respectively. The presence of rhamnose is characteristic only for biofilms from cultures of *D. desulfuricans* and gulose is detectable only in biofilms of *P. fluorescens*. Ribose released into biofilms comes most probably from nucleic acids and contributes 5% (w/w) to 9% (w/w) to neutral sugar content. The total amount of neutral sugar present in biofilms obtained from MS coupons calculated by using values from Table 12 and Table 15 is given in Table 16.

**Table 16: CHROMATOGRAPHIC ESTIMATION OF THE TOTAL AMOUNT OF NEUTRAL SUGAR (mg  $\pm$  SD) PRESENT IN BIOFILMS RECOVERED FROM 15 MS COUPONS AFTER 7 DAYS OF INCUBATION WITH BACTERIAL CULTURES.**

<i>P. fluorescens</i>	0.199 $\pm$ 0.02
<i>D. desulfuricans</i>	0.372 $\pm$ 0.07
<i>P. fluorescens</i> and <i>D. desulfuricans</i>	0.313 $\pm$ 0.07

Biofilms formed on MS surfaces by pure and mixed cultures of *D. desulfuricans* contain significantly more neutral sugars than biofilms developed on MS coupons in the presence of pure cultures of *P. fluorescens* . There is no significant difference in the amount of neutral sugars detected between biofilms from pure and mixed *Desulfovibrio* cultures by this technique.

### 3.4.3 DETERMINATION OF PROTEINS IN BIOFILMS REMOVED FROM MS AND SS COUPONS.

#### 3.4.3.1 Colorimetric estimation of protein level in biofilms.

Table 17 shows the amount of protein ( $\mu\text{g}/\text{mg}$ ) present in 7 and 28 days old biofilm samples. The protein levels were estimated by the Lowry method (section 2.6.4.1)

**Table 17: PROTEIN ( $\mu\text{g}/\text{mg} \pm \text{SD}$ ) PRESENT IN BIOFILMS FORMED ON 15 MS AND 15 SS COUPONS INCUBATED FOR 7 AND 28 DAYS WITH BACTERIAL CULTURES IN MEDIUM C.**

Inoculum	7 DAY OLD BIOFILM	
	ON MS	ON SS
<i>P. fluorescens</i>	751.60 $\pm$ 181.2	217.18 $\pm$ 15.46
<i>D. desulfuricans</i>	526.00 $\pm$ 181.9	363.15 $\pm$ 13.93
<i>P. fluorescens and D. desulfuricans</i>	694.13 $\pm$ 51.4	411.66 $\pm$ 68.3

Inoculum	28 DAY OLD BIOFILM	
	ON MS	ON SS
<i>P. fluorescens</i>	667.22 $\pm$ 262.2	272.20 $\pm$ 30.24
<i>D. desulfuricans</i>	715.00 $\pm$ 198.3	427.05 $\pm$ 14.77
<i>P. fluorescens and D. desulfuricans</i>	755.30 $\pm$ 163.9	459.00 $\pm$ 6.25

Data presented in Table 18 shows the total amount of protein detected in biofilms removed from steel coupons. Calculations are based on values listed in Tables 12 and 17.



**Table 18: COLORIMETRIC ESTIMATION OF THE TOTAL AMOUNT OF PROTEIN (mg  $\pm$ SD) DETECTED IN BIOFILMS REMOVED FROM 15 MS AND 15 SS INCUBATED FOR 7 AND 28 DAYS WITH BACTERIAL CULTURES IN MEDIUM C.**

Inoculum	7 DAY OLD BIOFILM	
	ON MS	ON SS
	total protein	total protein
<i>P. fluorescens</i>	77.93 $\pm$ 18.79	1.71 $\pm$ 0.12
<i>D. desulfuricans</i>	62.44 $\pm$ 21.59	3.66 $\pm$ 0.14
<i>P. fluorescens and D. desulfuricans</i>	70.80 $\pm$ 5.24	2.96 $\pm$ 0.49
Inoculum	28 DAY OLD BIOFILM	
	ON MS	ON SS
<i>P. fluorescens</i>	122.63 $\pm$ 47.4	2.85 $\pm$ 0.31
<i>D. desulfuricans</i>	180.11 $\pm$ 49.90	13.75 $\pm$ 0.47
<i>P. fluorescens and D. desulfuricans</i>	142.67 $\pm$ 30.90	8.91 $\pm$ 6.25

The total amount of protein detected in 7 and in 28 days old biofilms formed on SS surfaces is significantly lower than the level of protein found in biofilms developed on MS surfaces in all bacterial cultures.

The content of protein in biofilms developed on SS coupons becomes significantly greater with extended time of incubation regardless of culture type. Biofilms formed on MS coupons by pure and mixed cultures of *D. desulfuricans* contain a significantly higher level of protein with increased time of exposure to bacteria. No such tendency is observed in biofilms grown in pure cultures of *P. fluorescens*.

There is no significant difference in protein content between 7 day old biofilm developed on either SS coupons or on MS coupons regardless of culture type. Significantly more protein is detected in 28 day old biofilms formed on SS coupons by pure cultures of *Desulfovibrio* than in biofilms developed in pure and mixed *Pseudomonas* cultures. No such tendency is noticed when analysing protein level in biofilms removed from MS coupons.

### 3.4.3.2 SDS-GEL electrophoresis of proteins in biofilm samples.

Plate 7 shows proteins detected in biofilm samples by SDS-PAGE gel electrophoresis

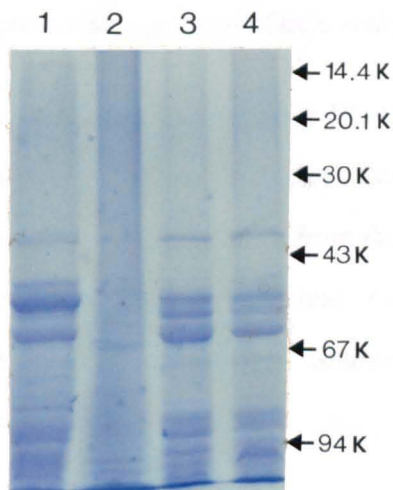

Pl. 7 SDS-gel stained with PAGE blue showing proteins present in biofilms removed from MS coupons. Each well was loaded with 0.08 mg of sample.

Lane 1: 7 day old *D. desulfuricans* biofilm

Lane 2: 7 day old mixed cultures biofilm

Lane 3: 7 day old *P. fluorescens* biofilm

Lane 4: 28 day old *P. fluorescens* biofilm

Gels visualising proteins present in biofilms removed from SS coupons (not shown) are similar to those shown in Plate 7, but the bands are fainter due to a lower protein content per 1mg of biofilm sample.

### 3.4.4 EDAX ANALYSIS OF BIOFILMS FORMED ON MS AND SS SURFACES

Biofilms formed on surfaces of MS and SS stubs were examined under SEM and analysed by EDAX to identify elements present on these surfaces.

#### 3.4.4.1 SEM observation of steel surfaces prior to EDAX analysis.

SEM observations of stainless steel stubs prepared for EDAX as described in section 2.8.3, incubated for 16 days with pure or mixed bacterial cultures (Plate 8) show no obvious macroscopic differences in surface appearance from those incubated in medium C without bacterial cells. The surfaces appear relatively clear of any deposit when observed under low magnification under the SEM (Plates 9 - 11). Stainless steel surfaces examined after 7 and 21 days do not differ.

Mild steel stubs incubated with pure or mixed bacterial cultures for 7, 16 and 21 days show greater diversity when viewed by SEM. Mild steel stubs incubated with *Pseudomonas* accumulate large amounts of non-continuous crystalline deposit, whereas surfaces exposed to *Desulfovibrio* or to mixed cultures are covered with an amorphous film (Plates 12 -15). Mild steel surfaces exposed to medium C alone (Plate 15) are covered with a crystalline deposit similar in appearance to that observed on surfaces exposed to *Pseudomonas*.

**Plate 8**

Mild and stainless steel stubs prepared for EDAX analysis after 16 days exposure to pure and mixed cultures of *D. desulfuricans* and *P. fluorescens*. Stainless steel stubs A, B, C, D, exposed to A: *D. desulfuricans*; B: uninoculated (control) stub; C: *P. fluorescens*; D: mixed cultures. (x1.7).

**Plates 9,10,11**

SEM micrographs of stainless steel surfaces prepared for EDAX analysis after 16 days incubation in medium C alone (Plate 9; x18.5); medium C with *P. fluorescens* (Plate 10; x14); and medium C with mixed cultures of *P. fluorescens* and *D. desulfuricans* (Plate 11; x14).

**Plates 12, 13, 14, 15**

SEM micrographs of mild steel surfaces prepared for EDAX analysis after 7 days incubation with *P. fluorescens* (Plate 12; x52); *D. desulfuricans* (Plate 13; x52); mixed cultures (Plate 14; x52); and in medium C alone (Plate 15; x52).

Pl.8

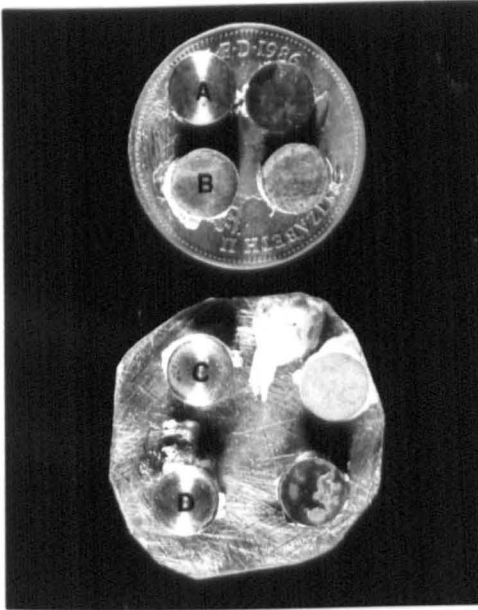

Pl.9

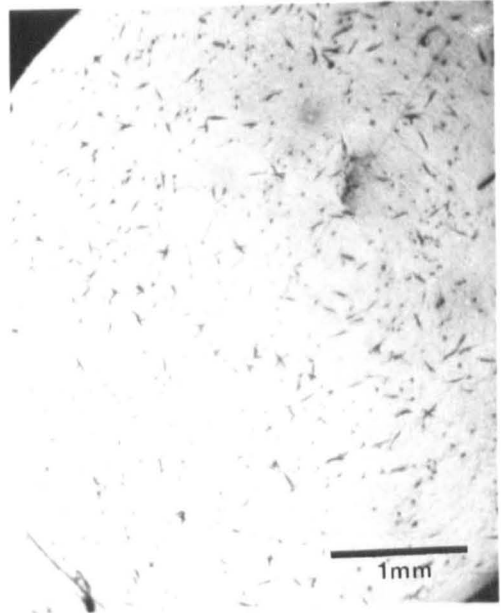

Pl.10

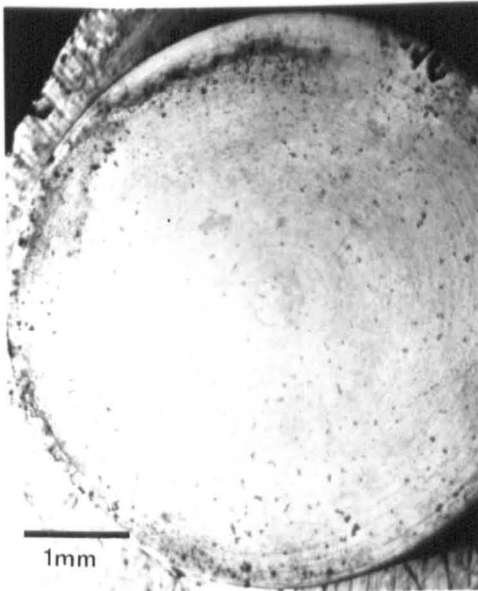

Pl.11



Pl.12

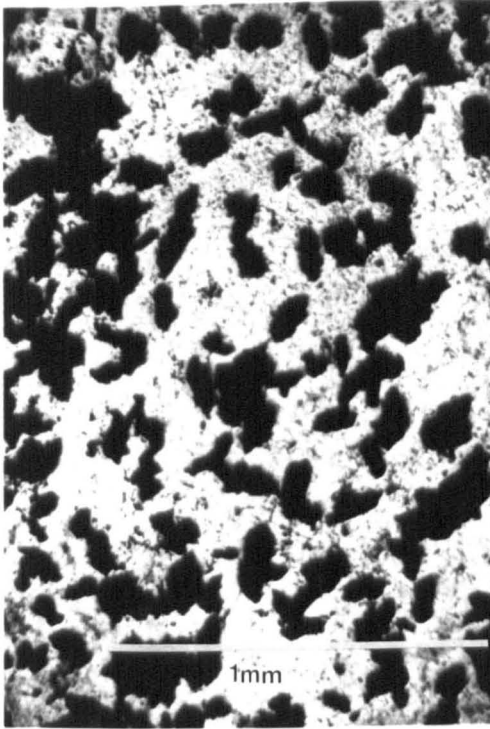

Pl.13

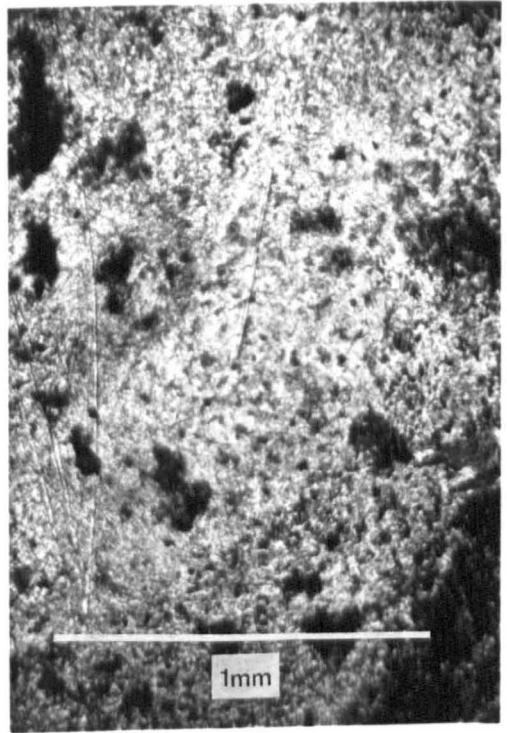

Pl.14



Pl.15



### 3.4.4.2 EDAX analysis of biofilms

The quantitative data obtained from EDAX spectra as described in section 2.8.1. representing amounts of main elements detected on MS and SS surfaces incubated with pure and mixed bacterial cultures for 7, 16 and 21 days is summarised in Table 19.

**Table 19: EDAX ANALYSIS OF ELEMENTS PRESENT ON MILD AND STAINLESS STEEL SURFACES EXPOSED TO PURE AND MIXED CULTURES OF *P. FLUORESCENS* AND *D. DESULFURICANS* IN MEDIUM C.**

Surface	Inoculum	-----7 day old-----		
		S	P	Fe
MS	Control	339	1573	45980
	<i>P. fluorescens</i>	3742	8582	54866
	<i>D. desulfuricans</i>	37519	5208	46528
	mixed	32161	4919	37928
SS	Control	8124	4224	67077
	<i>P. fluorescens</i>	7460	3896	54962
	<i>D. desulfuricans</i>	10775	4102	59834
	mixed	6912	3771	13844
Surface	Inoculum	-----16 day old-----		
		S	P	Fe
MS	Control	4485	2949	45349
	<i>P. fluorescens</i>	4222	3463	52314
	<i>D. desulfuricans</i>	22142	3359	46257
	mixed	20726	3159	25922
SS	Control	9715	5073	74522
	<i>P. fluorescens</i>	5016	2626	42429
	<i>D. desulfuricans</i>	12666	4656	77674
	mixed	5839	2813	45941
Surface	Inoculum	-----21 day old-----		
		S	P	Fe
MS	Control	4572	11592	51318
	<i>P. fluorescens</i>	6075	3995	28633
	<i>D. desulfuricans</i>	13578	2878	19553
	mixed	10918	2624	21551
SS	Control	6214	3866	25586
	<i>P. fluorescens</i>	8129	4065	49757
	<i>D. desulfuricans</i>	11576	3839	9945
	mixed	12332	4105	9972

Values are expressed in arbitrary units

Spectra of elements present on MS and SS surfaces reveal that the greatest variation occurs in levels of sulphur. The amount of sulphur detected on the surfaces of mild steel incubated with *D. desulfuricans* exceeds that for *P. fluorescens* and for bacteria-free controls by as much as 11 and 10 times respectively after 7 days of incubation (Plates 16 and 17). However, with time this difference becomes less pronounced and after 21 days the quantity of sulphur on mild steel surfaces incubated with *Desulfovibrio* is only 4 times greater than that on control surfaces (Plate 18) and 3 times that on surfaces incubated with *Pseudomonas* (Plate 19). The amount of sulphur present on mild steel incubated with *Desulfovibrio* is greater than the amount detected on surfaces incubated with mixed cultures at all periods of exposure.

The levels of sulphur detected on stainless steel surfaces are greater than those recorded on mild steel for control and *Pseudomonas* - incubated surfaces. Stainless steel surfaces incubated with *D. desulfuricans* and mixed *Desulfovibrio/Pseudomonas* accumulate less sulphur than mild steel. The difference in sulphur content of biofilms on stainless steel between surfaces incubated with *Desulfovibrio* and those incubated with mixed *Desulfovibrio/Pseudomonas* is not as great as in the case of mild steel, showing a maximum of 2 times increase after 16 days incubation with *Desulfovibrio* compared with mixed cultures. The amount of sulphur detected on stainless steel surfaces exposed to *Desulfovibrio* for 7 and 16 days is greater than that on surfaces in mixed cultures. The sulphur levels on these surfaces after 21 days shows a ratio of 1:0.93 (*Desulfovibrio* : mixed).

There is no great variation in the quantity of phosphorus on either mild or stainless steel surfaces. The amount detected by EDAX proved to be greater on control surfaces. On mild steel the amount of phosphorus detected on surfaces incubated with *Pseudomonas* exceeds that on those exposed to *Desulfovibrio* and mixed cultures. On stainless steel no such regular relationships are observed.



Plates 16, 17, 18, 19

EDAX analysis of elements present in biofilm formed on surfaces of mild steel stubs exposed to bacteria for 7 and 21 days. Peaks show ratios of element levels for surfaces exposed to:

16. *D. desulfuricans* and medium C only (7 days)

17. *D. desulfuricans* and *P. fluorescens* (7 days)

18. *D. desulfuricans* and medium C only (21 days)

19. *D. desulfuricans* and *P. fluorescens* (21 days).

PI.16

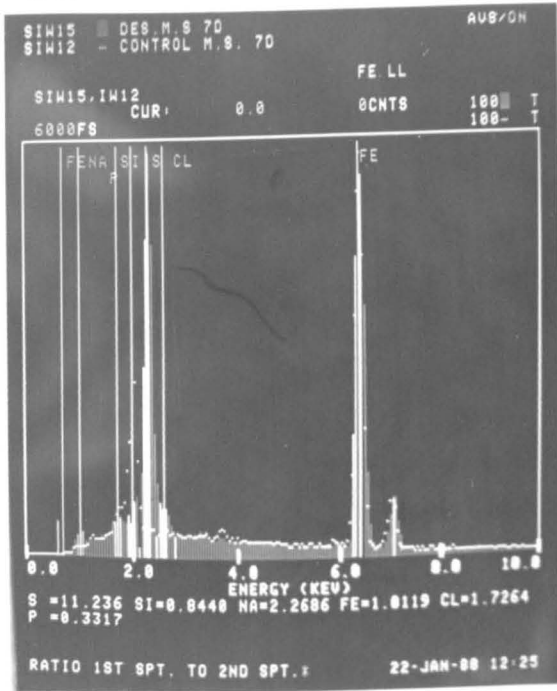

PI.17

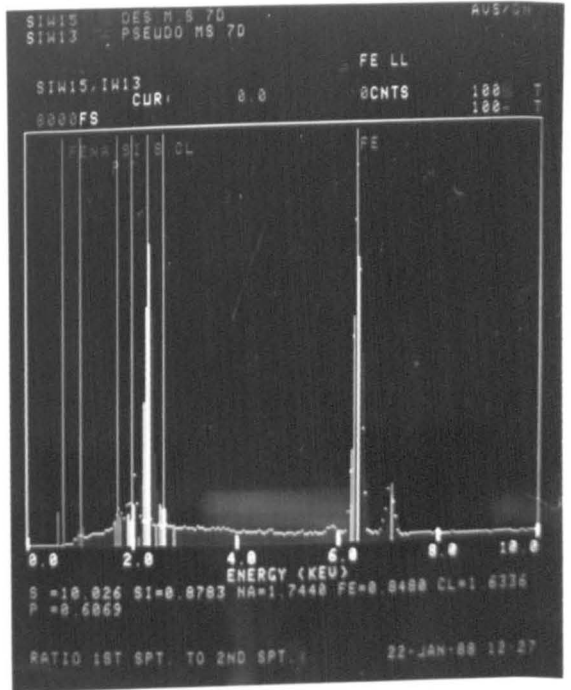

PI.18

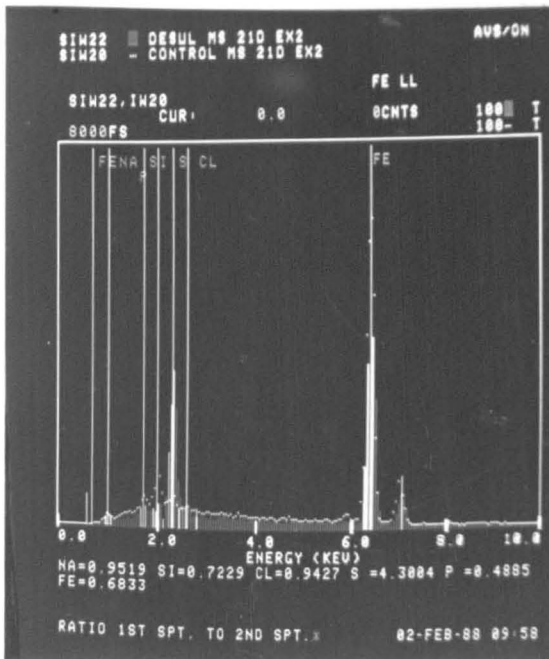

PI.19

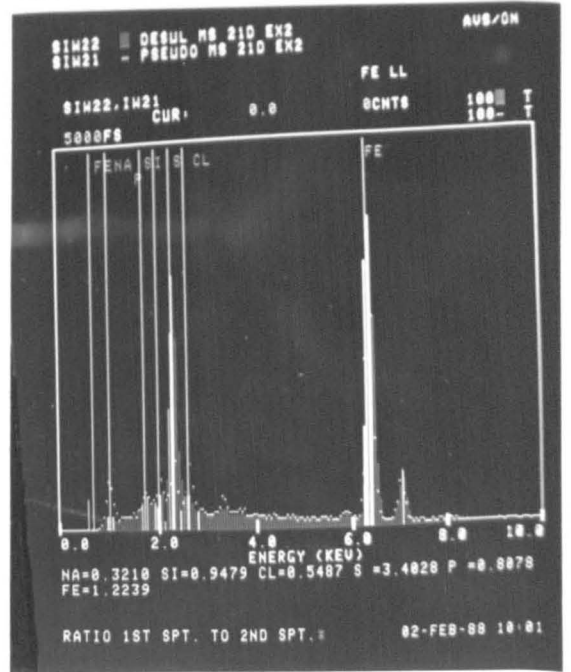

The level of iron recorded on mild steel surfaces incubated for 7 days is greatest for *Pseudomonas*, but after 21 days incubation this is the lowest. The amount of iron detected on mild steel surfaces incubated with *Pseudomonas* either in pure or mixed culture is generally less than that on controls, reaching its lowest value after 16 days of incubation. On stainless steel stubs the amount of iron detected after 21 days of incubation is highest on surfaces exposed to *Pseudomonas* and lowest on those exposed to *Desulfovibrio* (pure or mixed). The amount of iron found on stainless steel surfaces after 7 days incubation with *Desulfovibrio* exceeds by a factor of 4 the amount recorded on surfaces exposed to mixed bacterial cultures.

### 3.5 ANALYSIS OF BACTERIAL EPS RELEASED INTO CULTURE MEDIUM

The amount of crude EPS harvested from pure and mixed bacterial cultures incubated for 7 and 28 days with and without steel coupons is listed in Table 20.

**Table 20: DRY WEIGHTS OF EPS (mg  $\pm$ SD) PRECIPITATED FROM 500 ml CULTURE MEDIUM AFTER 7 DAYS INCUBATION WITH AND WITHOUT STEEL COUPONS.**

Inoculum	Sample type	7 day old EPS
<i>P. fluorescens</i>	MS	95.9 $\pm$ 26.6
	SS	79.2 $\pm$ 16.6
	coupon-free	73.6 $\pm$ 6.7
<i>D. desulfuricans</i>	MS	66.5 $\pm$ 14.4
	SS	68.0 $\pm$ 26.11
	coupon-free	48.6 $\pm$ 7.06
<i>P. fluorescens and D. desulfuricans</i>	MS	60.6 $\pm$ 12.2
	SS	55.1 $\pm$ 3.35
	coupon-free	42.6 $\pm$ 5.7
Inoculum	Sample type	28 day old EPS
<i>P. fluorescens</i>	MS	99.10 $\pm$ 1.30
	SS	80.26 $\pm$ 13.38
	coupon-free	79.17 $\pm$ 12.47
<i>D. desulfuricans</i>	MS	72.90 $\pm$ 23.9
	SS	70.20 $\pm$ 12.35
	coupon-free	52.65 $\pm$ 9.26
<i>P. fluorescens and D. desulfuricans</i>	MS	65.80 $\pm$ 21.6
	SS	56.10 $\pm$ 7.03
	coupon-free	45.70 $\pm$ 9.45

Analysis of variance shows that there is no significant difference in the amount of polymer recovered from the respective bacterial cultures incubated with or without steel coupons, regardless of incubation time.

The amount of polymer obtained from 7 and 28 day old *Pseudomonas* cultures is significantly greater than that recovered from the respective pure and mixed *Desulfovibrio* cultures when organisms are grown in the absence of steel surfaces, or when SS surfaces are present. No significant difference in polymer levels is observed between the cultures containing MS coupons irrespective of incubation duration.

Dry weight of precipitate collected from 500 ml of 7 day old sterile medium C is 6.5 mg, approximately 7 to 15 times lower than the amount of precipitate obtained from the same volume of medium C inoculated with bacteria incubated with and without steel coupons.

### **3.5.1 DETECTION OF CARBOHYDRATES PRESENT IN FREE EPS BY SDS-PAGE.**

Carbohydrates present in free bacterial EPS visualised on the SDS-gels did not differ to any great extent from those seen in gels of biofilms (section 3.4.1.1).

### **3.5.2 COLORIMETRIC ESTIMATION OF CARBOHYDRATES PRESENT IN FREE EPS.**

The total amount of neutral hexose (mg) present in crude EPS harvested after 7 and 28 days, estimated by colorimetric assay (section 2.6.3) is shown in Table 21.

**Table 21: COLORIMETRIC ESTIMATION OF THE TOTAL AMOUNT OF NEUTRAL HEXOSE (mg  $\pm$  SD) PRESENT IN EPS HARVESTED FROM 500ml OF BACTERIAL CULTURES INCUBATED FOR 7 AND 28 DAYS WITH AND WITHOUT STEEL COUPONS.**

Inoculum	7 days incubation	
	Sample type	Total sugar $\pm$ SD
<i>P. fluorescens</i>	MS	27.26 $\pm$ 2.71
	SS	18.81 $\pm$ 2.51
	coupon-free	17.34 $\pm$ 1.84
<i>D. desulfuricans</i>	MS	19.45 $\pm$ 1.33
	SS	19.18 $\pm$ 1.63
	coupon-free	12.89 $\pm$ 0.57
<i>P. fluorescens and D. desulfuricans</i>	MS	18.39 $\pm$ 0.63
	SS	16.02 $\pm$ 3.35
	coupon-free	11.65 $\pm$ 1.14
Inoculum	28 days incubation	
	Sample type	Total sugar $\pm$ SD
<i>P. fluorescens</i>	MS	28.46 $\pm$ 4.35
	SS	22.23 $\pm$ 4.03
	coupon-free	18.60 $\pm$ 4.05
<i>D. desulfuricans</i>	MS	22.05 $\pm$ 1.04
	SS	20.35 $\pm$ 1.73
	coupon-free	13.85 $\pm$ 1.53
<i>P. fluorescens and D. desulfuricans</i>	MS	21.83 $\pm$ 1.75
	SS	18.06 $\pm$ 2.40
	coupon-free	13.22 $\pm$ 2.62

Analysis of variance reveals that significantly more neutral hexose is present in EPS recovered after 7 and 28 days from pure cultures of *D. desulfuricans* incubated with MS or SS coupons compared with the amount detected in EPS harvested from coupon-free cultures. There are also significantly higher amounts of neutral hexose obtained from mixed *Desulfovibrio* cultures after 7 and 28 days of incubation in the presence of MS coupons and in EPS recovered from the cultures containing SS coupons collected after 7 days compared with coupon-free cultures. No significant increase in the total amount of neutral hexose is noticed between the EPS harvested after 28 days from mixed bacterial cultures grown in the presence of SS coupons and that from coupon-free cultures.

In the case of *P. fluorescens* , only EPS precipitated from the cultures grown for 28 days in the presence of MS coupons have significantly more neutral hexoses than EPS harvested from coupon-free cultures. Otherwise there is no significant difference in the neutral hexose level between EPS from cultures containing SS or MS coupons and coupon-free cultures.

EPS recovered after 7 and 28 days from mixed *Desulfovibrio* cultures grown in the presence of MS coupons have significantly more neutral hexoses than the respective EPS precipitated from the cultures containing SS coupons. No such tendency is noticed in the case of EPS from pure *Desulfovibrio* cultures.

The total amount of neutral hexoses present in EPS recovered after 7 days from *Pseudomonas* cultures containing MS coupons is significantly greater than that detected in EPS harvested from the cultures with SS coupons. Levels present in EPS isolated after 28 days from *P. fluorescens* cultures grown with MS coupons are not significantly different from those detected in EPS from SS coupon-containing cultures. Table 22 summarises the results obtained after subjecting data from Table 21 to analysis of variance.

**Table 22: THE RESULTS OF THE ANALYSES OF VARIANCE SHOWING DIFFERENCES BETWEEN THE TOTAL AMOUNT OF NEUTRAL HEXOSE DETECTED COLORIMETRICALLY IN FREE EPS RECOVERED FROM COUPON-CONTAINING AND COUPON-FREE BACTERIAL CULTURES.**

Inoculum	Comparison between cultural conditions	Statistical evaluation	
		7 days	28 days
<i>Pseudomonas</i>	MS / coupon-free	-	+
	SS / coupon-free	-	-
	MS / SS	+	-
<i>Desulfovibrio</i>	MS / coupon-free	+	+
	SS / coupon-free	+	+
	MS / SS	-	-
<i>Pseudomonas</i> and <i>Desulfovibrio</i>	MS / coupon-free	+	+
	SS / coupon-free	+	-
	MS / SS	+	+
"+"	significantly different		
"-"	not significantly different		

The total amount of neutral hexose present in EPS harvested from pure *Pseudomonas* cultures incubated with MS coupons is significantly higher than the total level detected in EPS of either pure or mixed *Desulfovibrio* cultures regardless of incubation time. No such trend can be observed in EPS obtained from cultures grown in the presence of SS coupons.

Significantly more neutral hexose is detected in EPS obtained from pure *Desulfovibrio* cultures incubated for 7 days with SS coupons than in EPS precipitated from mixed cultures. Otherwise no significant difference is noticed in the total levels of neutral hexoses between EPS recovered from pure or from mixed *Desulfovibrio* cultures regardless of culture conditions and of the duration of incubation. Table 23 summarises the results of the analyses of variance.

**Table 23: THE RESULTS OF THE ANALYSES OF VARIANCE SHOWING DIFFERENCES BETWEEN THE TOTAL AMOUNT OF NEUTRAL HEXOSE DETECTED COLORIMETRICALLY IN FREE EPS RECOVERED FROM BACTERIAL CULTURES GROWN WITH STEEL COUPONS.**

Comparison between inoculum type	MS coupons		SS coupons	
	7 days	28 days	7 days	28 days
<i>P/D</i>	+	+	-	-
<i>P/IPD</i>	+	+	-	-
<i>D/IPD</i>	-	-	+	-

- P* - *P. fluorescens*
- D* - *D. desulfuricans*
- PD* - *P. fluorescens* and *D. desulfuricans*
- "+" significantly different
- "-" not significantly different



### 3.5.3 CHROMATOGRAPHIC ANALYSIS OF CARBOHYDRATE PRESENT IN BACTERIAL EPS

The results of GC-MS and GC-FID analysis of carbohydrate composition of EPS harvested from 7 day old pure and mixed cultures of *D. desulfuricans* and *P. fluorescens* incubated with MS and SS coupons are presented in Tables 24,25 and 26.

**Table 24: CARBOHYDRATES FROM EPS OF *D. DESULFURICANS* ( $\mu\text{g}/\text{mg} \pm \text{SD}$ ) INCUBATED FOR 7 DAYS IN MEDIUM C WITH AND WITHOUT STEEL SURFACES.**

Type of sugar	MS	SS	coupon-free
Rhamnose	0.409 $\pm$ 0.1	trace	0.144 $\pm$ 0.02
Mannose	16.675 $\pm$ 0.24	9.367 $\pm$ 0.11	3.153 $\pm$ 0.05
Glucose	1.386 $\pm$ 0.01	1.899 $\pm$ 0.04	2.798 $\pm$ 0.18
Galactose	0.256 $\pm$ 0.01	0.467 $\pm$ 0.04	1.214 $\pm$ 0.18
Xylose	-	-	0.275 $\pm$ 0.01
Altrose	-	0.614 $\pm$ 0.03	-
Ribose	trace	trace	0.581 $\pm$ 0.02
Total	18.726 $\pm$ 0.09	12.347 $\pm$ 0.22	8.165 $\pm$ 0.46

- not detected

Mannose and glucose are the major carbohydrate components identified in EPS isolated from cultures of *D. desulfuricans*. Mannose contributes 89% w/w and 76% w/w to the total sugar content of EPS produced by these bacteria in the presence of MS and SS coupons respectively. The content of glucose is 7% w/w for cultures grown with MS and 15% w/w for cultures grown with SS coupons. The amount of mannose and glucose in EPS extracted from *D. desulfuricans* cultures incubated without coupons is 38% w/w and 34% w/w respectively. The total sugar concentration of EPS harvested from cultures of *D. desulfuricans* grown with coupons is 2.3 times greater for MS and 1.5 times higher for SS than the amount detected in EPS from coupon-free cultures.

**Table 25: CARBOHYDRATES FROM EPS OF *P. FLUORESCENS* ( $\mu\text{g}/\text{mg} \pm\text{SD}$ ) INCUBATED FOR 7 DAYS IN MEDIUM C WITH AND WITHOUT STEEL SURFACES.**

Type of sugar	MS	SS	coupon-free
Rhamnose	trace	$0.336 \pm 0.035$	$0.228 \pm 0.07$
Mannose	$45.159 \pm 0.312$	$42.312 \pm 0.250$	$50.920 \pm 0.46$
Glucose	$18.320 \pm 0.244$	$12.699 \pm 0.370$	$15.796 \pm 0.08$
Galactose	$1.880 \pm 0.279$	$0.373 \pm 0.080$	$0.466 \pm 0.02$
Xylose	-	-	$0.237 \pm 0.07$
Arabinose	$0.386 \pm 0.007$	-	$0.259 \pm 0.01$
Ribose	$3.590 \pm 0.062$	$5.640 \pm 0.070$	$8.779 \pm 0.03$
Total	$69.335 \pm 0.8940$	$61.360 \pm 0.805$	$76.687 \pm 0.74$

- not detected

The total sugar content per 1 mg of EPS isolated from cultures of *P. fluorescens* incubated with and without steel coupons does not vary to any great extent between the cultures. Mannose and glucose contribute on average 90% w/w to the total carbohydrate content of *P. fluorescens* EPS regardless of growth conditions (ie. the absence or presence of steel coupons). Mannose reaches its highest level, 77% w/w, in control coupon-free samples.

**Table 26: CARBOHYDRATES FROM EPS OF MIXED CULTURES OF *P. FLUORESCENS* AND *D. DESULFURICANS* ( $\mu\text{g}/\text{mg} \pm\text{SD}$ ) INCUBATED FOR 7 DAYS IN MEDIUM C WITH AND WITHOUT STEEL COUPONS.**

Type of sugar	MS	SS	coupon-free
Mannose	$30.214 \pm 0.362$	$26.929 \pm 0.48$	$32.191 \pm 0.11$
Glucose	$15.009 \pm 0.211$	$8.404 \pm 0.129$	$2.830 \pm 0.09$
Galactose	trace	$0.837 \pm 0.02$	$0.475 \pm 0.01$
Arabinose	trace	$2.350 \pm 0.05$	trace
Altrose	-	trace	-
Ribose	trace	trace	$2.816 \pm 0.10$
Total	$45.223 \pm 0.573$	$38.520 \pm 0.679$	$38.312 \pm 0.31$

- not detected

EPS isolated from mixed cultures of *P. fluorescens* and *D. desulfuricans* contain the highest amount of sugar in the case of cultures grown with MS coupons. Mannose and glucose are the only components detected in significant amounts in these samples.

Mannose and glucose together contribute 86% w/w and 91% w/w to total sugar level for EPS harvested from mixed cultures incubated with SS and without steel coupons respectively.

The total amount of neutral sugars detected chromatographically in EPS precipitated from bacterial cultures is given in Table 27.

**Table 27: TOTAL AMOUNT OF NEUTRAL SUGARS (mg  $\pm$ SD) DETECTED CHROMATOGRAPHICALLY IN EPS OBTAINED FROM BACTERIAL CULTURES INCUBATED FOR 7 DAYS WITH AND WITHOUT STEEL COUPONS (VALUES CALCULATED FROM TABLES 20, 24,25 AND 26).**

Inoculum	Sample type	EPS Total Sugar
<i>P. fluorescens</i>	MS	6.65 $\pm$ 1.85
	SS	4.86 $\pm$ 1.02
	coupon-free	5.64 $\pm$ 0.52
<i>D. desulfuricans</i>	MS	1.24 $\pm$ 0.27
	SS	0.84 $\pm$ 0.28
	coupon-free	0.39 $\pm$ 0.04
<i>P. fluorescens</i> and <i>D. desulfuricans</i>	MS	2.74 $\pm$ 0.55
	SS	2.28 $\pm$ 0.14
	coupon-free	1.63 $\pm$ 0.30

Analysis of variance shows that significantly more neutral sugar is present in EPS recovered from cultures of *D. desulfuricans* incubated with MS or SS coupons compared with the amount detected in EPS harvested from coupon-free cultures. This observation is also true for EPS samples obtained from mixed bacterial cultures. In the case of EPS recovered from *P. fluorescens* cultures there is no significant difference in the neutral sugar content of EPS from the cultures incubated with or without steel coupons. The quantity of neutral sugars in EPS of *P. fluorescens* is significantly higher than the level of sugars in EPS of either pure or mixed cultures of *D. desulfuricans* regardless of cultural conditions. The content of neutral sugars in all types of EPS harvested from *D. desulfuricans* cultures is significantly lower than that of EPS obtained from mixed cultures. The results of the analyses of variance are summarised in Table 28.

**Table 28: THE RESULTS OF THE ANALYSES OF VARIANCE SHOWING DIFFERENCES BETWEEN THE TOTAL AMOUNT OF NEUTRAL SUGARS DETECTED CHROMATOGRAPHICALLY IN FREE EPS RECOVERED FROM BACTERIAL CULTURES GROWN WITH AND WITHOUT STEEL COUPONS AFTER 7 DAYS INCUBATION IN MEDIUM C.**

Inoculum	Comparison between culture type	Statistical evaluation
<i>Pseudomonas</i>	MS / coupon-free	-
	SS / coupon-free	-
	MS / SS	-
<i>Desulfovibrio</i>	MS / coupon-free	+
	SS / coupon-free	+
	MS / SS	-
<i>Pseudomonas</i> and <i>Desulfovibrio</i>	MS / coupon-free	+
	SS / coupon-free	+
	MS / SS	-
Comparison between inoculum types	MS coupons	SS coupons
<i>PID</i>	+	+
<i>PIPD</i>	+	+
<i>DIPD</i>	+	+
<i>P</i>	-	<i>P. fluorescens</i>
<i>D</i>	-	<i>D. desulfuricans</i>
<i>PD</i>	-	<i>P. fluorescens</i> and <i>D. desulfuricans</i>
+	-	significantly different
-	-	not significantly different

#### 3.5.4 ANALYSIS OF CARBOHYDRATES PRESENT IN PRECIPITATE RECOVERED FROM STERILE MEDIUM C

The percentage of neutral hexoses detected by colorimetric assay in 6.5 mg (dry weight) precipitate collected from 500 ml of 7 day old, sterile medium C is 40% w/w. Types and quantities of sugars detected by GC-FID are presented in Table 29.

**Table 29: CARBOHYDRATES DETECTED IN PRECIPITATE FROM STERILE MEDIUM C ( $\mu\text{g}/\text{mg} \pm \text{SD}$ ).**

Type of sugar	Quantity
Mannose	$8.745 \pm 3.70$
Glucose	$1.275 \pm 0.11$
Galactose	$2.048 \pm 0.314$
Ribose	$6.244 \pm 1.12$
<b>Total</b>	<b><math>18.312 \pm 5.244</math></b>

Mannose and ribose are the main detected components of medium C precipitate and they contribute 48% w/w and 34% w/w to the total neutral sugar content respectively. Glucose (7% w/w of total sugar) and galactose (11% w/w of total sugar) are also present.

The contribution of sugars from sterile medium C (% weight) towards the neutral sugar detected in EPS from bacterial cultures is shown in Table 30.

**Table 30: CONTRIBUTION OF SUGAR (% WEIGHT) FROM STERILE MEDIUM C TOWARDS THE TOTAL AMOUNT OF SUGAR PRESENT IN EPS RECOVERED FROM BACTERIAL CULTURES INCUBATED FOR 7 DAYS WITH AND WITHOUT STEEL COUPONS (VALUES CALCULATED FROM TABLES 27 AND 29).**

Inoculum	Sample type	%weight of sugar from C
<i>P. fluorescens</i>	MS	1.77
	SS	2.44
	coupon-free	2.10
<i>D. desulfuricans</i>	MS	9.59
	SS	14.16
	coupon-free	30.50
<i>P. fluorescens and D. desulfuricans</i>	MS	4.34
	SS	5.21
	coupon-free	7.30

The calculations of all the values listed in Table 30 are based on the following equation:

% weight of sugar (mg) from sterile medium C =  $\frac{a \times b}{c} \times 100\%$  where

a - total dry weight of precipitate from C (mg)

b -  $\mu\text{g}$  of total sugar detected in 1 mg of precipitate from C (Table 29)

c - total amount of sugar (mg) present in given EPS sample (Table 27).

The possible contribution of sugar present in the precipitate from sterile medium C towards the total level of sugar detected in free EPS samples varies from 1.8% w/w to 30.5% w/w.

### 3.5.5 ANALYSIS OF PROTEINS PRESENT IN FREE EPS SAMPLES.

#### 3.5.5.1 Determination of protein in free EPS samples

The amount of protein present in free EPS collected from 7 and 28 day old bacterial cultures incubated with and without steel coupons was established by the Lowry method.

The results of the assay are presented in Table 31.

**Table 31: COLORIMETRIC ESTIMATION OF PROTEINS (% w/w) PRESENT IN FREE EPS HARVESTED FROM 7 AND 28 DAY OLD BACTERIAL CULTURES INCUBATED WITH AND WITHOUT STEEL COUPONS.**

Inoculum	Sample type	7 day old EPS % w/w protein
<i>P. fluorescens</i>	MS	46
	SS	53
	coupon-free	51
<i>D. desulfuricans</i>	MS	47
	SS	49
	coupon-free	51
<i>P. fluorescens</i> and <i>D. desulfuricans</i>	MS	51
	SS	52
	coupon-free	54
Inoculum	Sample type	28 day old EPS % w/w protein
<i>P. fluorescens</i>	MS	48
	SS	54
	coupon-free	63
<i>D. desulfuricans</i>	MS	47
	SS	50
	coupon-free	62
<i>P. fluorescens</i> and <i>D. desulfuricans</i>	MS	57
	SS	57
	coupon-free	65

Proteins contribute 46% - 65% to the weight of the EPS precipitated from the bacterial cultures. The amount of protein present in free EPS harvested from bacterial cultures does not vary to a great extent with prolonged time of incubation. The increase in protein content of EPS recovered from coupon - free cultures over that from cultures grown in the presence of steel coupons is noticeable in 28 but not 7 day old EPS samples.

### 3.5.5.2 SDS gel electrophoresis of proteins present in free EPS samples.

SDS-PAGE gel electrophoresis confirms the presence of proteins in free EPS samples. Plate 20 shows the photograph of a gel loaded with the EPS samples. Many protein bands are present.

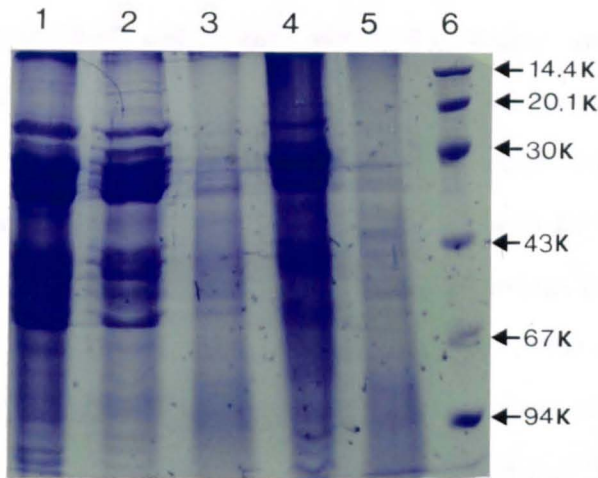

Pl. 20 SDS-gel stained with PAGE blue visualising proteins present in free EPS samples harvested from 7 day old bacterial cultures. Each well was loaded with 0.08 mg of sample.

Lane 1, EPS from mixed cultures incubated with MS coupons  
Lane 2, EPS from mixed cultures incubated without steel coupons  
Lane 3, EPS from *Desulfovibrio* cultures incubated with MS coupons  
Lane 4, EPS from *Pseudomonas* cultures incubated with MS coupons  
Lane 5, EPS from *Desulfovibrio* cultures incubated with SS coupons  
Lane 6, Mixture of 6 protein standards  
(Electrophoresis Calibration Kit, Pharmacia LKB)

Gels loaded with 28 day old EPS samples have similar appearance to the ones run with 7 day old EPS samples.



### **3.6 SEM EXAMINATION OF SS AND MS SURFACES USED AS ELECTRODES IN POTENTIOSTATIC MEASUREMENTS**

SEM studies of the surfaces, used later as electrodes in kinetic polarisation studies, were performed as described in section 2.5.5, prior to potentiostatic measurements. The micrographs of SS (Plates 21 to 28) and MS (Plates 29 to 41) electrodes demonstrate the formation of biofilms on surfaces of these electrodes and the concurrent corrosion.

#### **3.6.1 EXAMINATION OF SS SURFACES**

SS electrodes incubated for 7 and 16 days with *P. fluorescens* are poorly colonised by bacteria. Very few cells, mostly single, can be seen on the surface (Plates 23 and 24). After 7 days of incubation pure and mixed cultures of *D. desulfuricans* form very patchy biofilms on SS consisting mainly of single cells linked with EPS (Plates 25 and 27). Prolonged incubation for 16 days does not result in any obvious increase in the biofilm bulk (Plates 26 and 28) and no difference can be observed in the abundance of biofilm between pure and mixed cultures of *Desulfovibrio*. The surfaces of SS electrodes kept in sterile medium C appear unchanged with time (Plates 21 and 22). The appearance of SS electrodes incubated for 21 days with and without bacterial cultures (not shown) does not differ from that found after 16 days.

SEM observation of SS electrodes cleaned in Clark's solution (section 2.8.2) reveals no obvious corrosion under either control or experimental conditions.

**Plates 21 and 22**

**SEM micrographs of stainless steel surfaces incubated in sterile medium C for 7 days (Plate 21) and for 16 days (Plate 22) at 32°C.**

**Plates 23 and 24**

**SEM micrographs of stainless steel surfaces incubated in sterile medium C inoculated with *P. fluorescens* for 7 days (Plate 23) and for 16 days (Plate 24) at 32°C.**

**Plates 25, 26, 27 and 28**

**SEM micrographs of stainless steel surfaces after incubation at 32°C in sterile medium C inoculated with pure cultures of *D. desulfuricans* for 7 days (Plate 25) and for 16 days (Plate 26) and after exposure to mixed cultures of *D. desulfuricans* and *P. fluorescens* for 7 days (Plate 27) and 16 days (Plate 28).**

PI.21

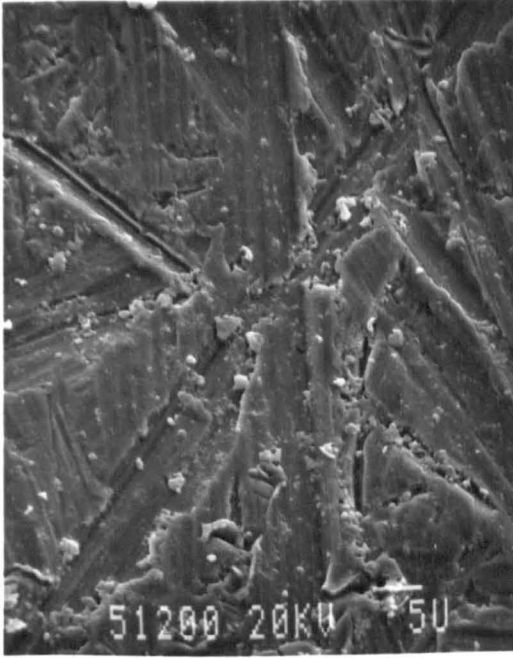

PI.22

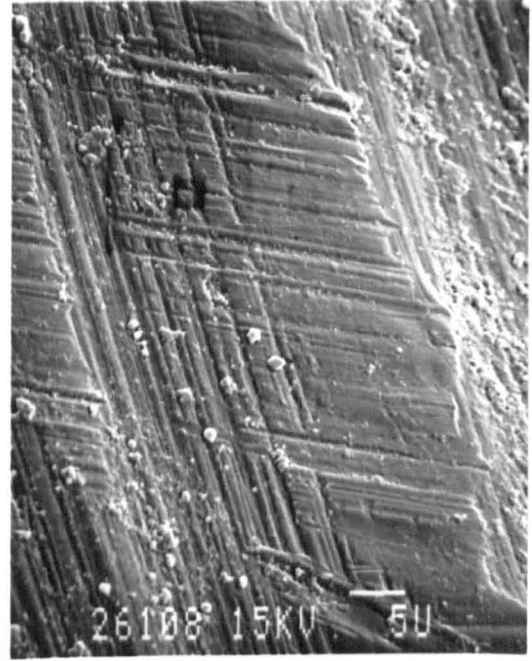

PI.23

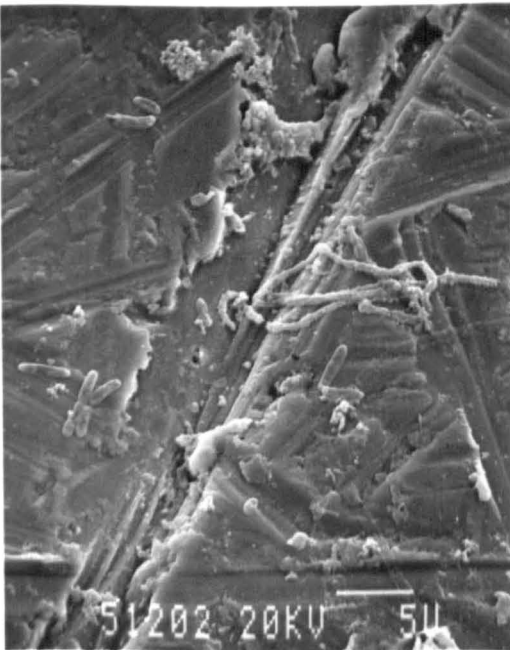

PI.24

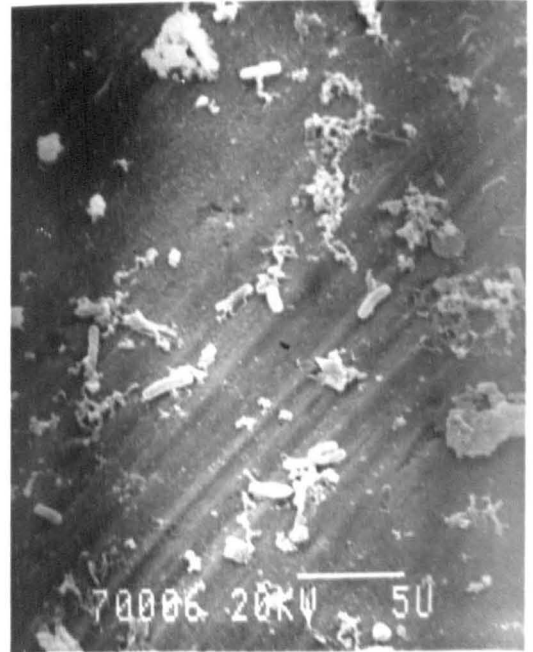

PI.25



PI.26

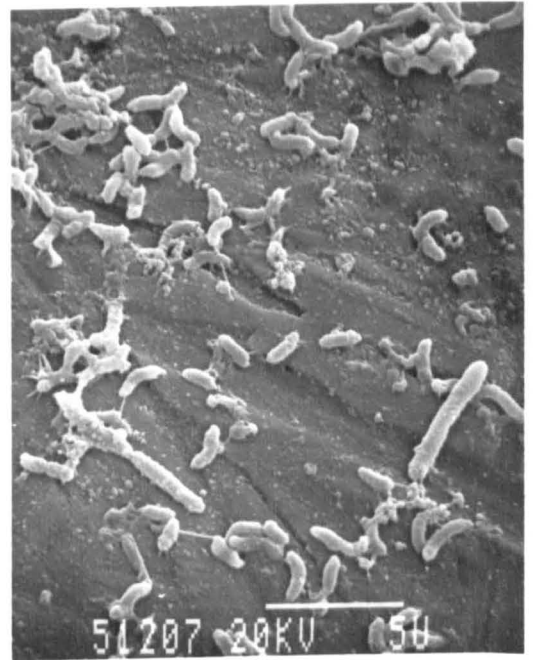

PI.27

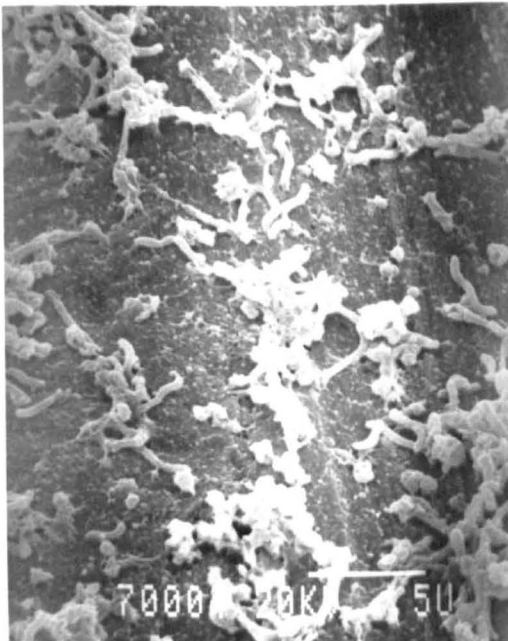

PI.28



### 3.6.2 EXAMINATION OF MS SURFACES.

Surfaces of MS electrodes incubated for 7,16 and 21 days with *P. fluorescens* are covered with a thin layer of deposit on which a scanty biofilm is formed (Plates 29, 30b and 31b). Some lenticular crystals are seen above the deposit layer (Plate 31b). Groups of these crystals with bacterial cells scattered around and upon them are more evident on the surfaces after 16 and 21 days of incubation (Plates 30a, and 31a). The crystals can also be observed on control surfaces (Plates 38a).

MS surfaces incubated in pure cultures of *D. desulfuricans* are uniformly covered with a multilayered biofilm, consisting of bacterial cells, EPS and large amounts of corrosion products. The latter were identified by their morphology as mainly ferrous compounds such as oxides and sulphides (Engel and Klingele, 1981). The thickness of this biofilm appears to increase with prolonged incubation time up to 16 days (Plates 32, 33a,b and 34a,b).

Biofilms formed by mixed cultures are somewhat more patchy than those developed in pure *Desulfovibrio* cultures (Plates 35a,b, 36a,b and 37a,b), *P. fluorescens* being outnumbered by *D. desulfuricans*.

On removal of 21 day old biofilms from the MS electrode surfaces as described in section 2.8.1, a degree of corrosion can be seen on all surfaces including controls. Extensive pitting of MS occurs in pure and mixed *Desulfovibrio* cultures (Plates 39a,b and 40a,b). Corrosion of MS surfaces kept in pure *Pseudomonas* cultures seems to be less pronounced (Plates 41a,b). However on uncleaned specimens disruption of the surface coating reveals localised severe corrosion (Plates 31b,c). The lowest level of corrosion occurs on control surfaces (Plates 38 a,b,c).

**Plates 29,30a,b, and 31a,b,c.**

**SEM micrographs of biofilms formed on the surfaces of MS stubs after incubation at 32°C in medium C inoculated with *P. fluorescens* for 7 days (Plate29), 16 days (Plates 30a,b) and 21 days (Plates 31a,b,c). Plates 31b and 31c show corrosion of mild steel occurring along grain boundaries and within grains where the layer of surface coating is disrupted.**

**Plates 32, 33a,b, 34a,b**

**SEM micrographs of biofilms developed on the surfaces of MS stubs after incubation at 32°C in medium C inoculated with pure cultures of *D. desulfuricans* for 7 days (Plate 32), 16 days (Plates 33a,b) and 21 days (Plates 34a,b).**

**Plates 33b and 34b show higher magnification of areas marked in Plates 33a and 34a respectively.**

PI.29

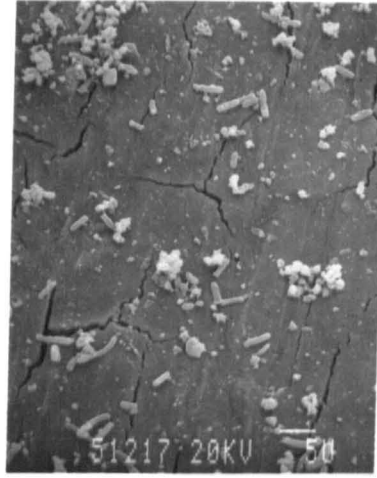

PI.30a



PI.30b

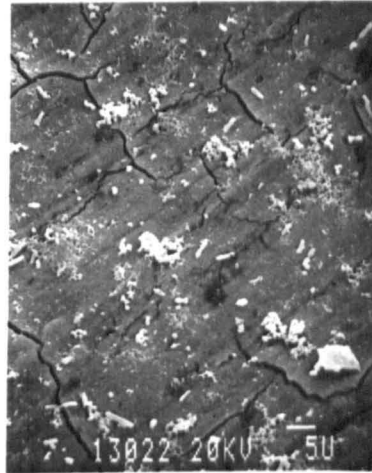

PI.31a

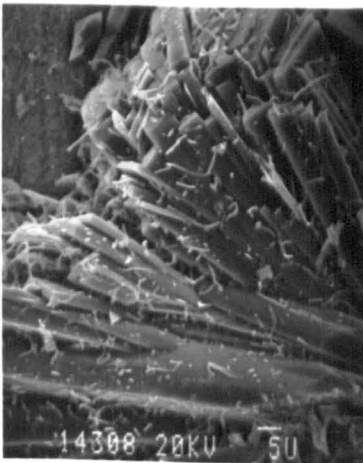

PI.31b

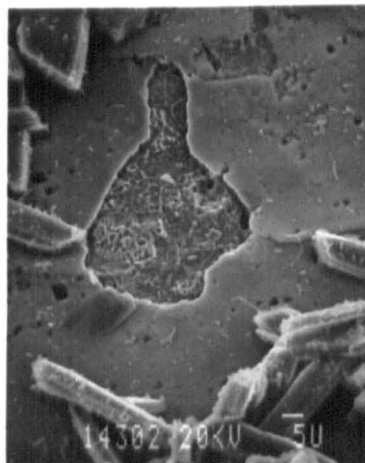

PI.31c

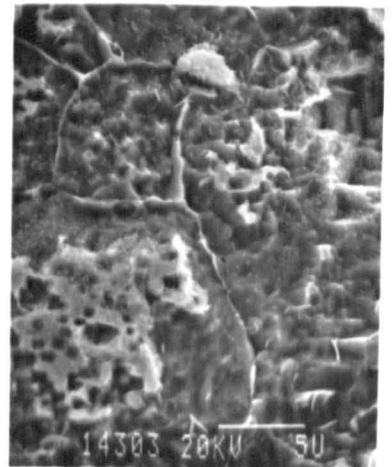

PI.32

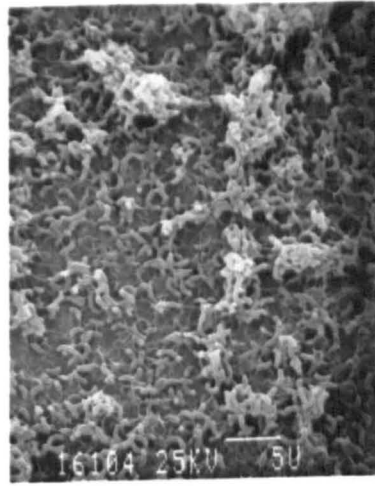

PI.33a



PI.33b

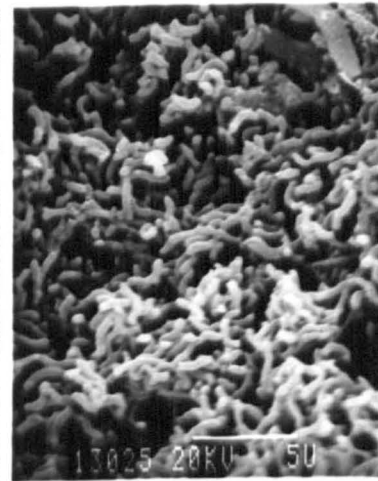

PI.34a

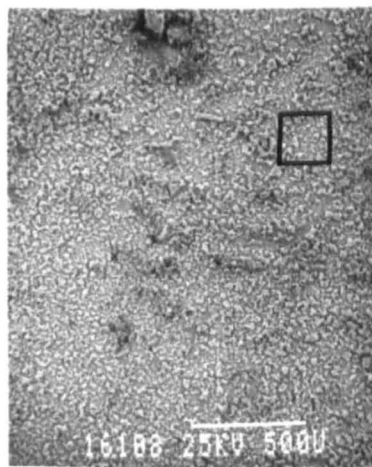

PI.34b

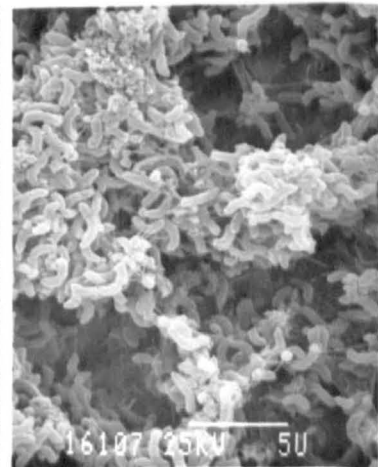



Plates 35a,b, 36a,b and 37a,b.

SEM micrographs of biofilms formed on the surfaces of mild steel after exposure to mixed cultures of *D. desulfuricans* and *P. fluorescens* grown in medium C at 32°C for 7 days (Plates 35a,b), 16 days (Plates 36a,b) and for 21 days (Plates 37a,b). Only few cells of *P. fluorescens* are visible in the upper part of the biofilm (arrowed).

Plates 38 a,b,c.

SEM micrographs of MS surfaces incubated in sterile medium C for 21 days at 32°C. Lenticular crystals are deposited on electrode surface (Plate 38a) and the initiation of pitting can be seen (Plate 38a,b).

Plates 39a,b, 40a,b and 41a,b.

SEM micrographs of MS surfaces incubated for 21 days at 32°C in medium C inoculated with pure cultures of *D. desulfuricans* (Plates 39a,b), mixed cultures of *D. desulfuricans* and *P. fluorescens* (Plates 40a,b) and with pure cultures of *P. fluorescens* (Plates 41a,b). Surfaces were cleaned in Clark's solution prior to SEM examination.

PI. 35a

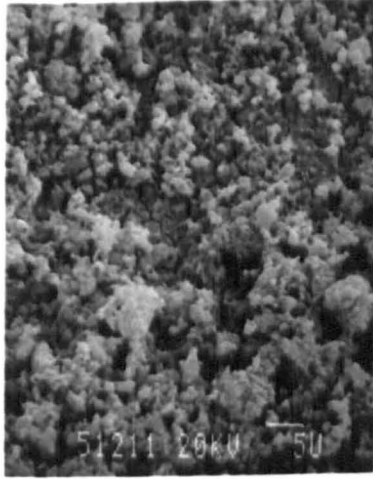

PI. 35b

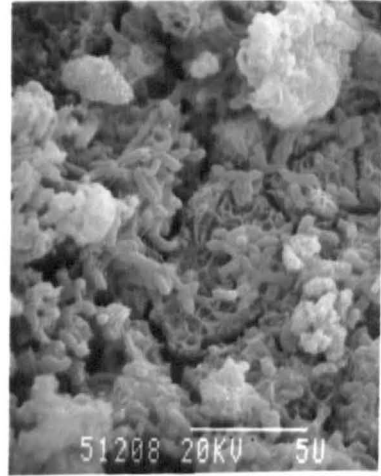

PI. 36a

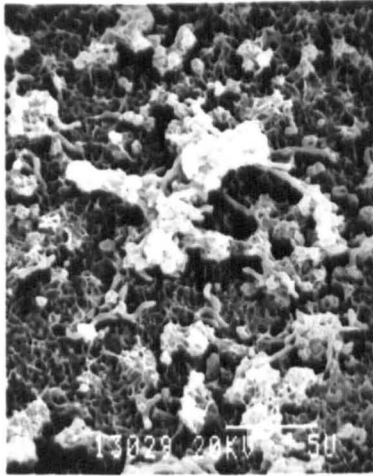

PI. 36b

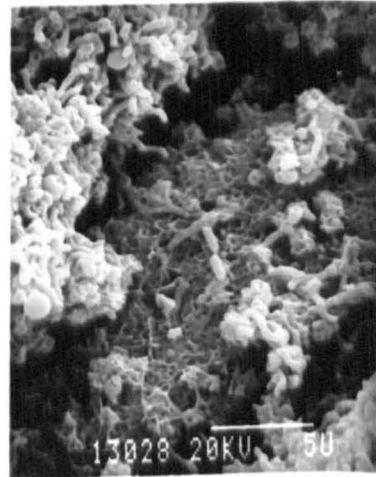

PI. 37a



PI. 37b

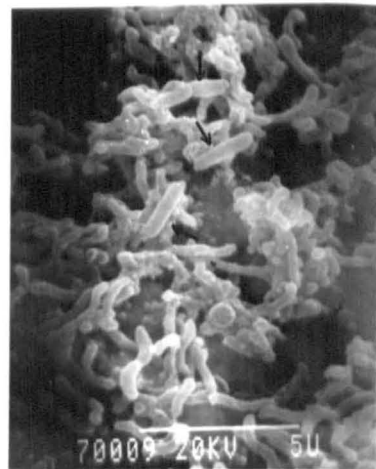

Pl. 38a

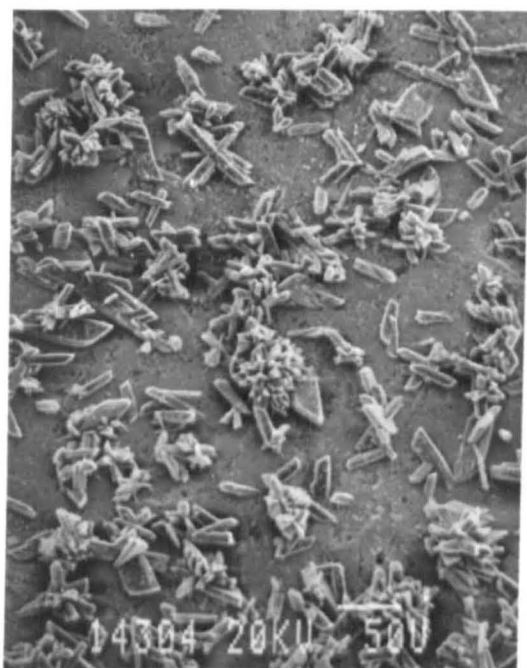

Pl. 38b



Pl. 38c

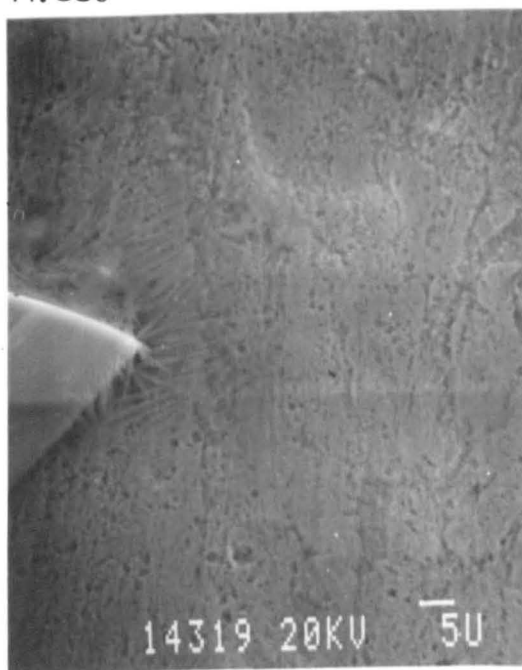

PI.39 a

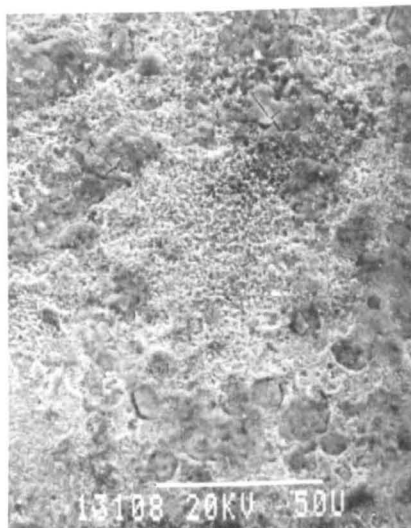

PI.39 b

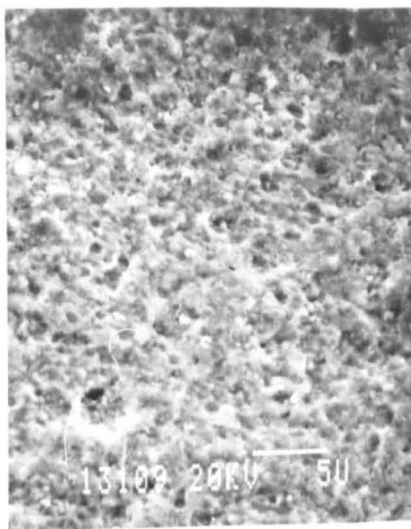

PI.40 a

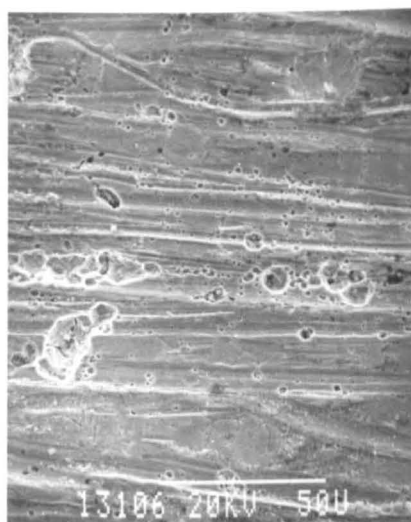

PI.40 b

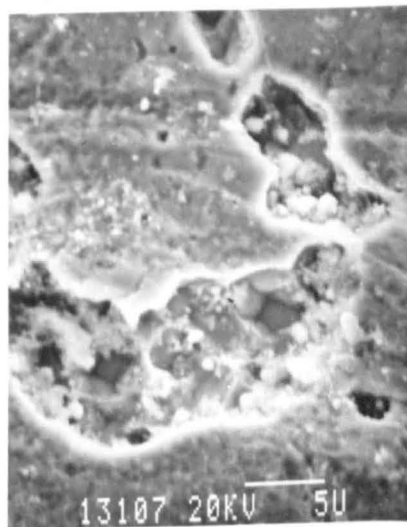

PI.41 a

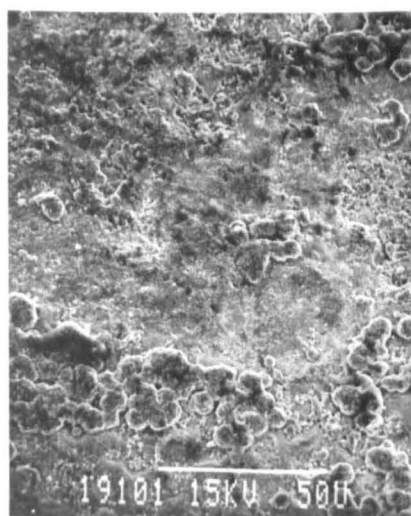

PI.41 b

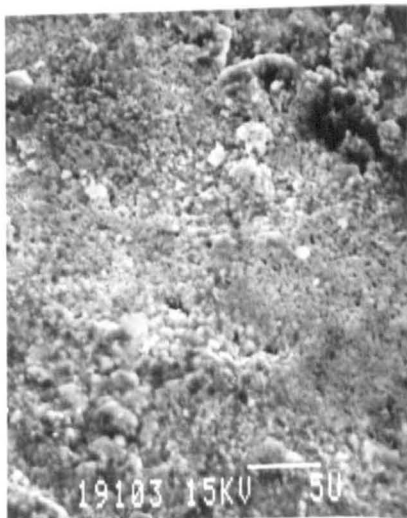

### 3.7 KINETIC POLARISATION STUDIES

Visual observations of mild and stainless steel stubs incubated with bacterial cultures as described in section 2.4.1 demonstrate a black coating of ferrous sulphide over the surface of the electrodes in the presence of *D. desulfuricans*. On SS this film is patchy and easily detached from the surface with the slightest movement of the electrode, unlike the uniform, much thicker and compact film developed on MS electrodes. The surfaces of MS electrodes incubated with *P. fluorescens* are covered with a dull deposit. No such coating is noticed on SS electrodes.

Cathodic and anodic polarisation curves for MS and SS electrodes were obtained as described in section 2.8.1.2. The shape of the polarisation curves obtained from measurements in sterile saline solution does not differ from the shape of the curves recorded in their respective incubation media and because of their similarity the former curves are omitted from the results shown in Figures 11 - 20.

A slight increase in the open circuit potential for MS electrodes is noticed when measurements are taken in saline solution compared with potential values recorded in culture media. This could be due to disturbance of the biofilm on the electrode surface caused during handling. The opposite tendency, a slight fall in the resting potential in saline solution, usually ascribed to oxygen scavenging by the steel from the solution, is observed for SS electrodes.

#### 3.7.1 POLARISATION CURVES FOR MS ELECTRODES

##### 3.7.1.1 Cathodic curves

Figure 11 shows that the cathodic polarisation curves of MS electrodes incubated with *P. fluorescens* remain essentially unchanged with increasing time of their exposure to bacteria from 7 to 21 days.

The cathodic polarisation curves show the increase in corrodibility of MS electrodes incubated with pure and mixed cultures of *D. desulfuricans* over a period of time. Figure 12 represents the polarisation curves obtained in pure cultures of *D. desulfuricans* incubated with MS electrodes from 7 to 21 days. The curve for 16 day incubation does not differ much from the curve obtained after 7 days of bacterial growth. However, there is an increase in corrodibility of MS in *Desulfovibrio* cultures exposed to bacteria for 21 days.

Figure 13 shows that cathodic depolarisation of MS electrodes incubated with mixed cultures of *D. desulfuricans* and *P. fluorescens* occurs after 16 days of bacterial growth. After 21 days the cathodic process in this culture is inhibited; the polarisation curve does not differ from the curve obtained after 7 days of exposure.

The characteristics of MS electrodes in sterile medium C show decrease of current density for given potential with time, indicating that inhibition of cathodic corrosion occurs in the absence of bacteria (Figure 14).

#### 3.7.1.2 Anodic curves

The anodic polarisation curves of MS electrodes in pure and mixed bacterial cultures (Figures 11-13) differ from the curves obtained in the absence of bacteria (Figure 14) by the appearance of many passive - active transitions. These transitions, at which a sharp increase in current density for given potential value is observed on the anodic curve, are very extensive in pure and mixed *Desulfovibrio* cultures (Figures 12 and 13 respectively) and much less pronounced in *P. fluorescens* cultures (Figure 11). The anodic characteristic of MS exposed for 21 days to *P. fluorescens* shows slight passivation of MS electrodes (Figure 11), which is not observed in other bacterial cultures (Figures 12 and 13).

#### 3.7.1.3 Polarisation curves after biofilm removal.

The removal from MS electrodes of 7 day old biofilm formed by *D. desulfuricans* results in an increase of corrosion current density in both cathodic and anodic regions of the polarisation curve (Figure 16). The cathodic and anodic depolarisation is less pronounced

when the 7 day old mixed culture biofilm is removed from the surface of the MS electrode (Figure 15). The pitting potential ( $E_p$ ), defined as the potential below which the metal is passive and above which pitting is initiated and indicated by a sharp inflection to higher current densities in the anodic curve, was determined on removal of the 7 day old biofilm and remeasurement of the polarisation curves. The  $E_p$  for pure *Desulfovibrio* cultures was lower than that for mixed cultures (-750 mV and -590 mV respectively). No  $E_p$  values were apparent for control or *Pseudomonas* cultures.

Figures 11 to 14.

Polarisation curves for mild steel incubated for 7, 16 and 21 days in medium C inoculated with *P. fluorescens* (Figure 11), *D. desulfuricans* (Figure 12), mixed cultures of *P. fluorescens* and *D. desulfuricans* (Figure 13), and in the uninoculated (control) medium C (Figure 14).

Figures 15 to 16

Polarisation curves for mild steel incubated for 7 days in medium C inoculated with mixed cultures of *P. fluorescens* and *D. desulfuricans* (Figure 15), and pure *D. desulfuricans* cultures (Figure 16), with biofilm present on their electrode surfaces and with biofilm removed.



Fig. 11

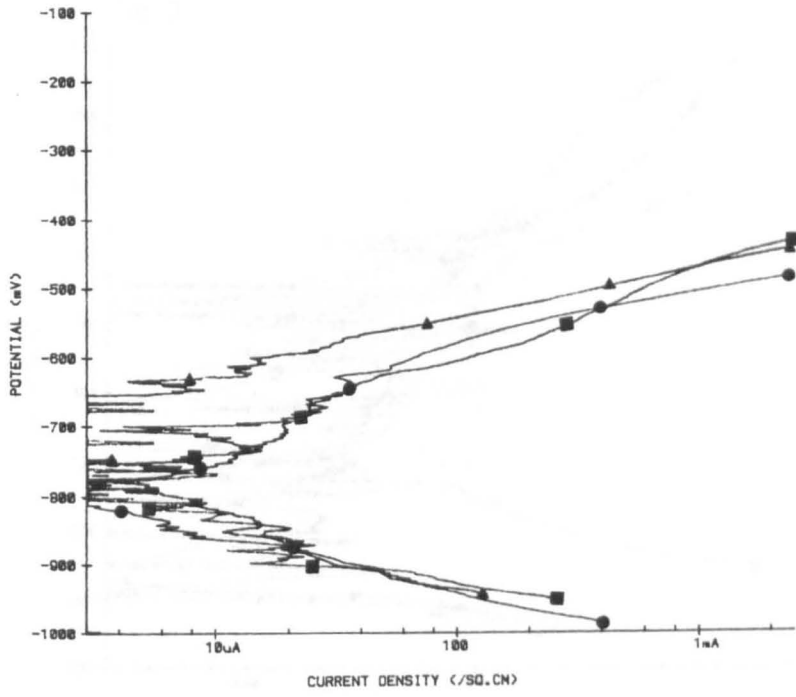

- 7 days
- 16 days
- ▲- 21 days

Fig. 12

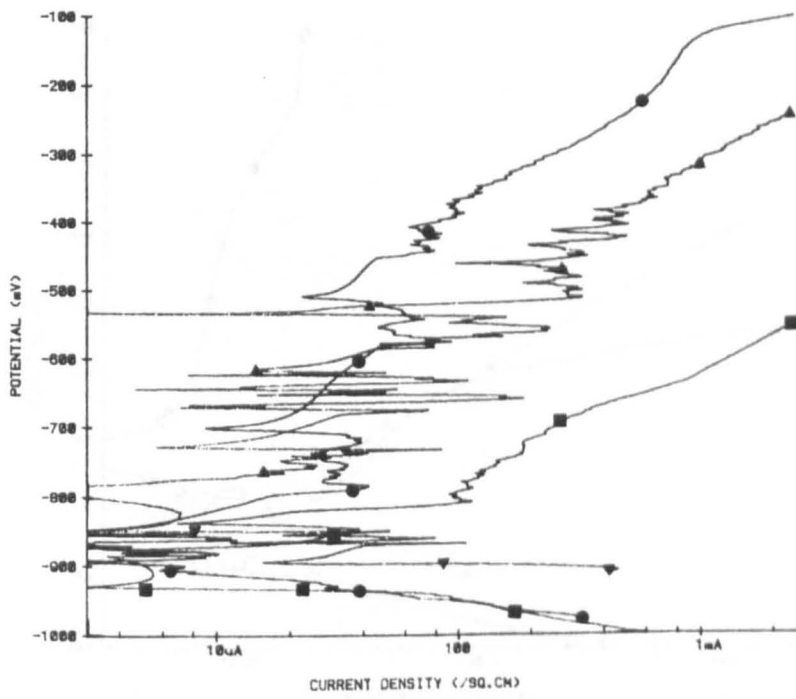
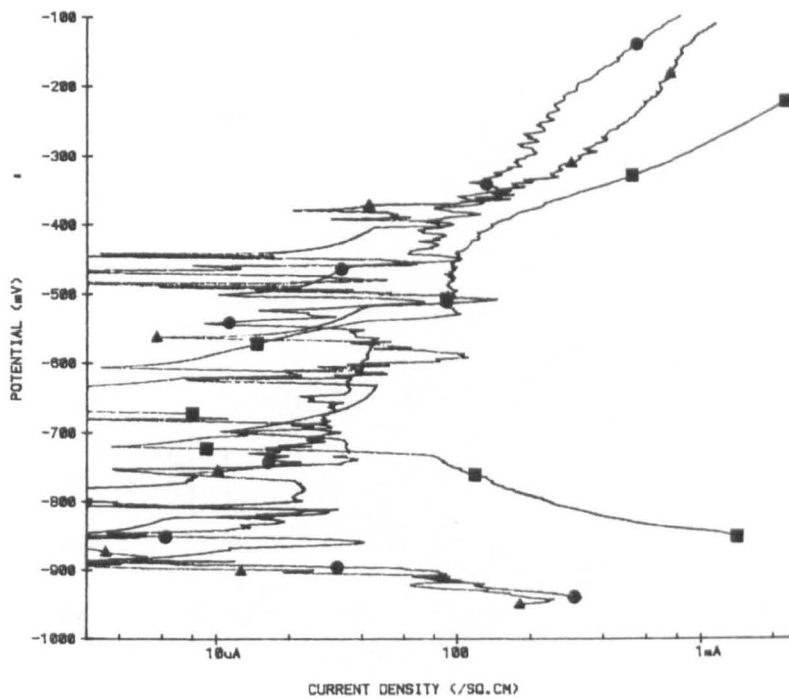

Fig.13



- 7 days
- 16 days
- ▲- 21 days

Fig.14

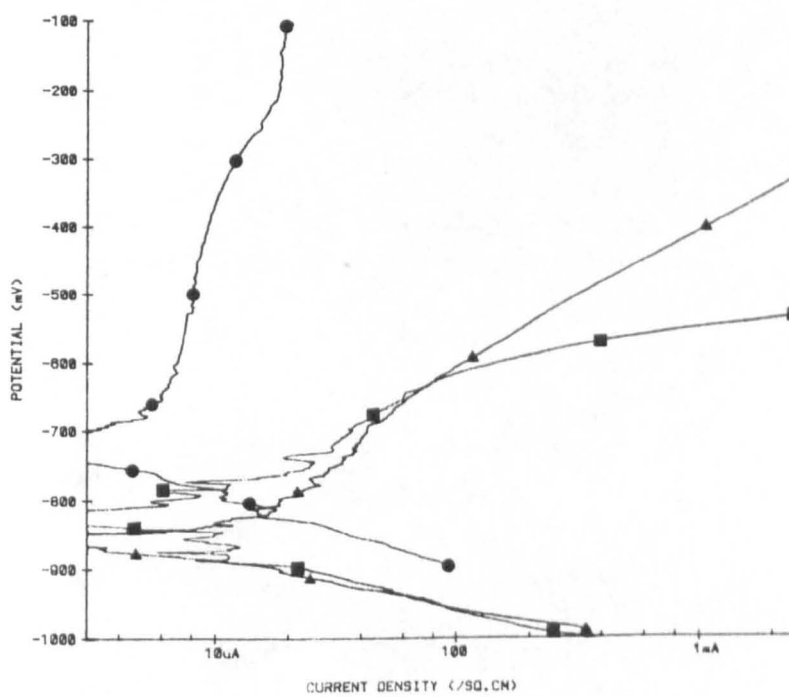
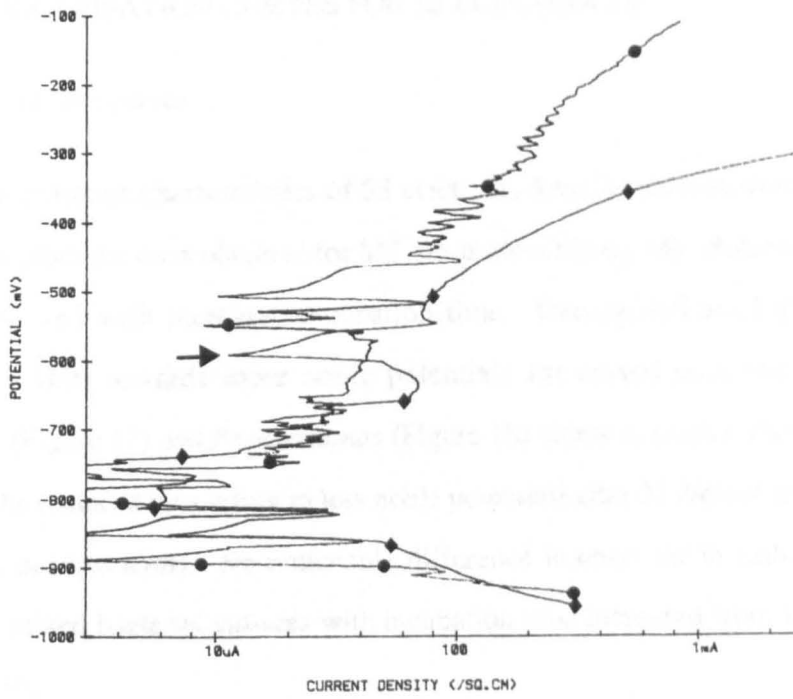

Fig.15



- ● - surface with biofilm

- ◆ - biofilm removed from surface

Arrows indicate  $E_p$  values

Fig.16

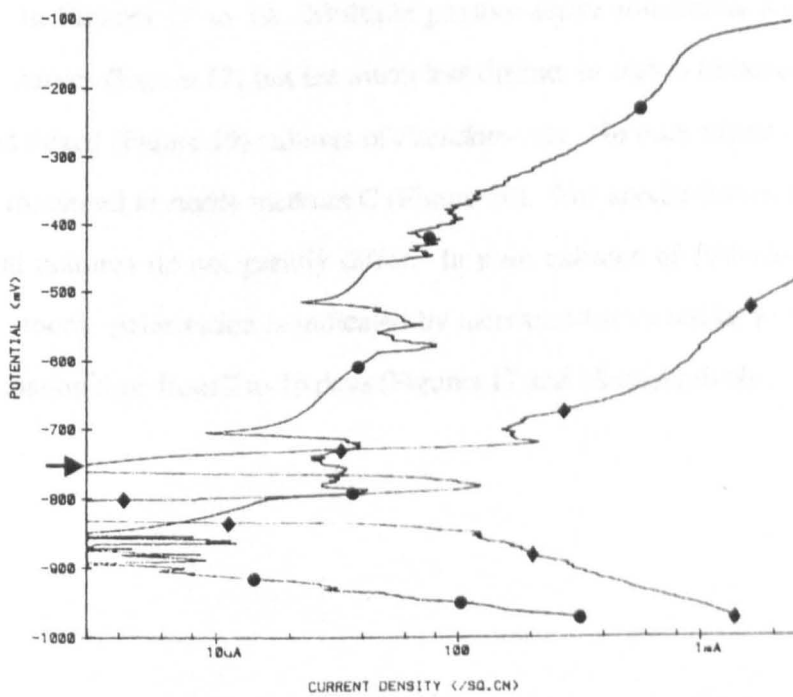

### 3.7.2 POLARISATION CURVES FOR SS ELECTRODES

#### 3.7.2.1 Cathodic curves

The cathodic polarisation characteristics of SS electrodes kept in sterile medium C (Figure 20) do not vary from the ones obtained for MS electrodes (Figure 14). Polarisation of the cathode is observed with increased incubation time. Depolarisation of the cathode, expressed as a shift towards more noble potentials for curves obtained from pure *Desulfovibrio* (Figure 17) and *Pseudomonas* (Figure 18) cultures, occurs after 16 days of incubation, to be replaced by a return to less noble potentials after 21 days of incubation in the case of *D. desulfuricans*. No noticeable difference is observed in cathodic curves obtained from mixed bacterial cultures with incubation time increased from 7 days to 21 days (Figure 19).

#### 3.7.2.2 Anodic curves.

Anodic polarisation curves for SS electrodes in sterile medium C are shown in Figure 20 and in the presence of active pure and mixed cultures of *P. fluorescens* and *D. desulfuricans* in Figures 17 to 19. Multiple passive-active transitions are visible on *Desulfovibrio* curves (Figure 17) but are much less distinct in curves obtained from pure (Figure 18) and mixed (Figure 19) cultures of *Pseudomonas*. No such transitions show on anodic curves measured in sterile medium C (Figure 20). The anodic curves for pure and mixed bacterial cultures do not greatly differ. In pure cultures of *Pseudomonas* and *Desulfovibrio* anodic polarisation is indicated by increased (more noble) potentials with prolonged incubation time from 7 to 16 days (Figures 17 and 18 respectively).

**Figures 17 to 20**

**Polarisation curves for stainless steel incubated for 7, 16 and 21 days in medium C inoculated with *P. fluorescens* (Figure 17), *D. desulfuricans* (Figure 18) and mixed cultures of *P. fluorescens* and *D. desulfuricans* (Figure 19) and in uninoculated (control) medium C (Figure 20).**

Fig.17

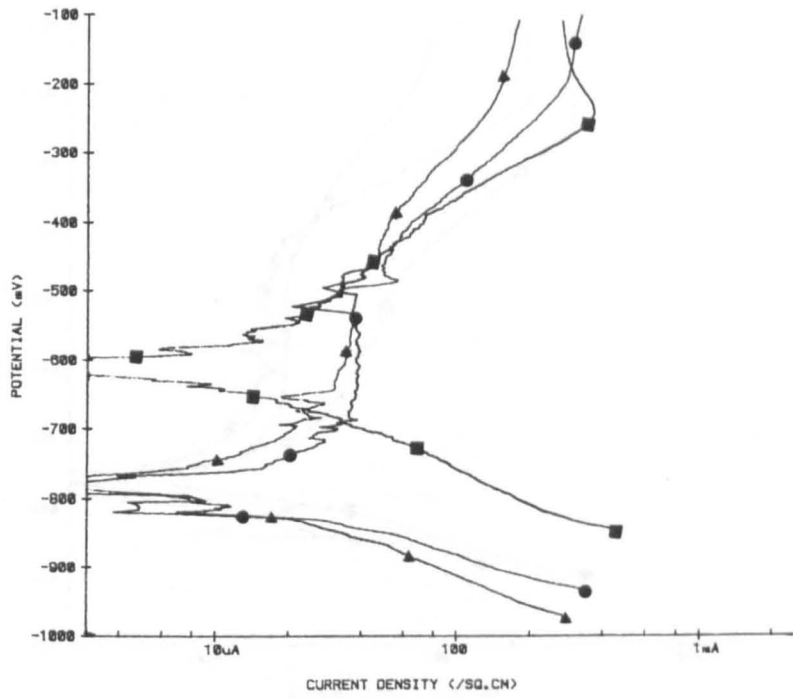

- 7 days
- 16 days
- ▲- 21 days

Fig.18

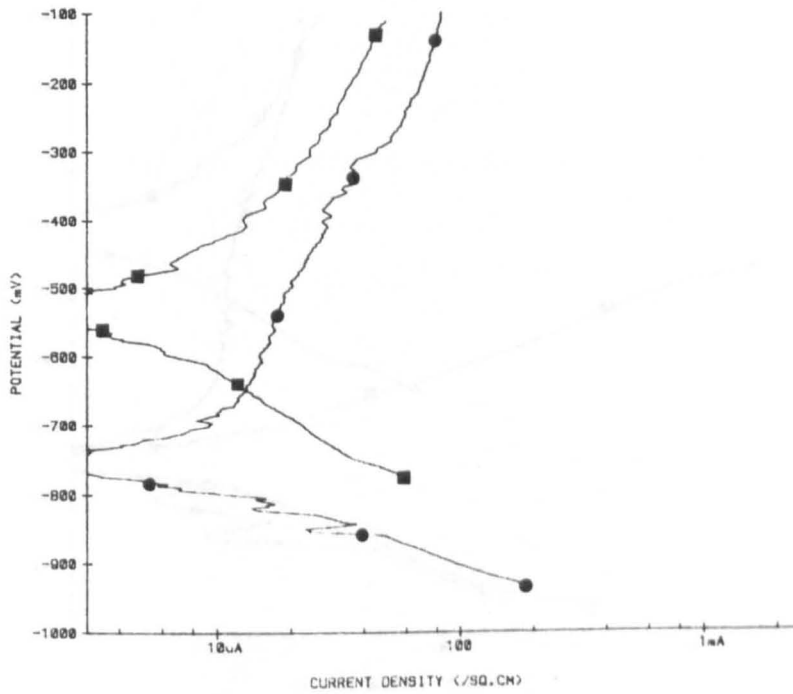
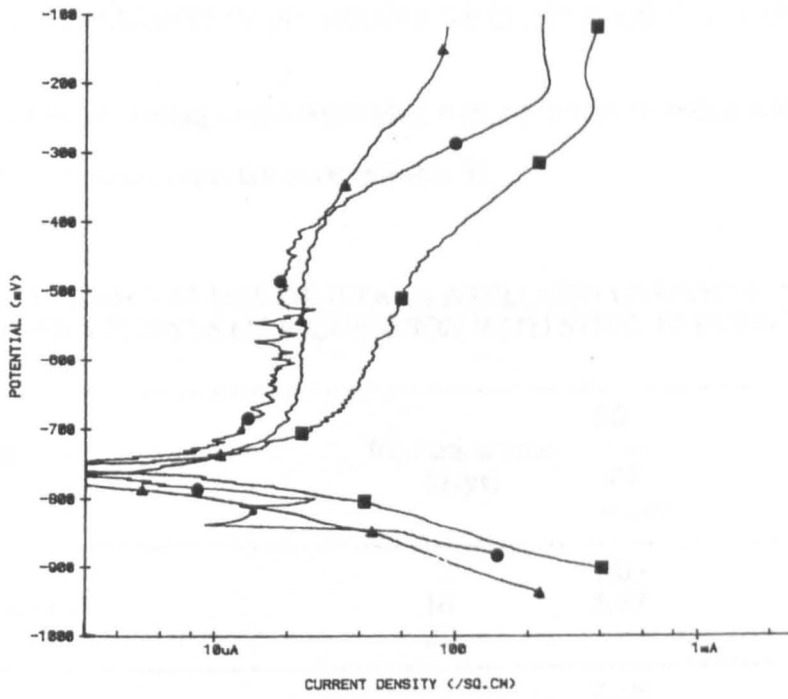
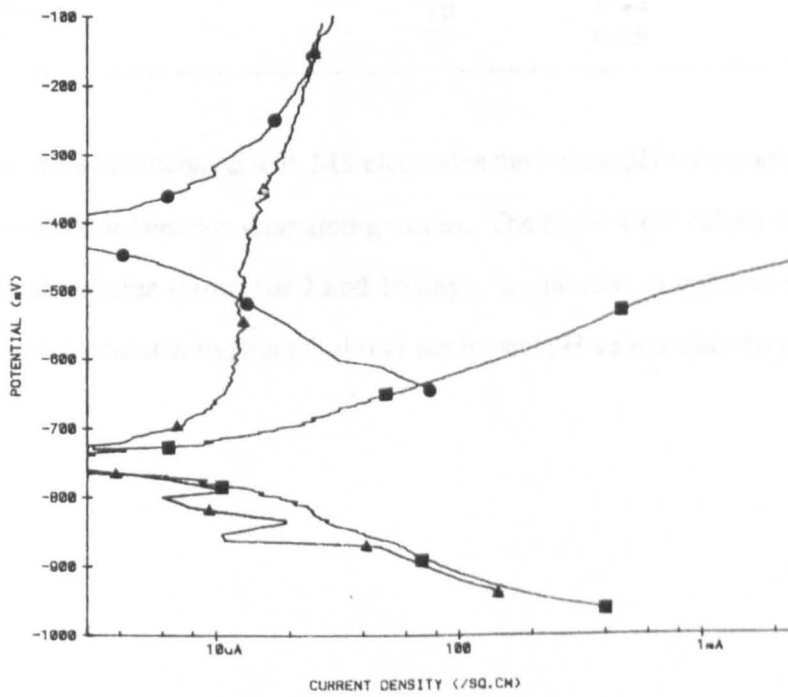

Fig.19



- 7 days
- 16 days
- ▲- 21 days

Fig.20



### 3.7.3 MEASUREMENTS OF pH VALUES OF ELECTRODE-CONTAINING MEDIA

The pH values of incubating media containing steel electrodes recorded immediately prior to potentiostatic measurements are listed in Table 32.

**Table 32: THE pH VALUES OF INOCULATED AND UNINOCULATED MEDIA AFTER 7, 16 AND 21 DAYS OF INCUBATION WITH STEEL ELECTRODES.**

Inoculum	Incubation time (days)	SS	MS
		pH values	pH values
<i>P. fluorescens</i>	7	7.05	7.16
	16	6.87	6.8
	21	-	6.87
<i>D. desulfuricans</i>	7	7.18	7.02
	16	7.10	7.10
	21	7.05	7.16
<i>P. fluorescens</i> and <i>D. desulfuricans</i>	7	7.03	8.77
	16	7.08	8.24
	21	6.91	7.15
Uninoculated Medium C Control	7	7.25	6.98
	16	6.94	7.03
	21	6.75	7.21

Amongst the cultures incubated with MS electrodes the lowest pH values are noticed for 16 and 21 days old *Pseudomonas* -containing media. The highest pH values are recorded for mixed bacterial cultures grown for 7 and 16 days. In the case of cultures incubated with SS electrodes uninoculated medium C shows the lowest pH values after 16 and 21 days.



## **CHAPTER FOUR**

### **DISCUSSION, CONCLUSIONS AND RECOMMENDATIONS**

#### 4.1 INITIAL ATTACHMENT OF BACTERIA TO STEEL SURFACES

To determine the role of bacterial surface carbohydrate containing molecules such as lipopolysaccharides (LPS) in the early attachment of *D. desulfuricans* and *P. fluorescens* to mild steel, lectins, known for their unique ability to bind specific carbohydrates, have been employed (section 3.2.2). Since no lectin is known to bind only glucose specifically, Concanavalin A (ConA) was chosen in this study for its ability to interact with glucose as well as other sugars. Wheat germ agglutinin (WGA) was selected as it is capable of specific binding to N-acetylglucosamine and its di- and tri-saccharide forms (Gallagher et al., 1983). The significant decrease in attachment of WGA and ConA treated cells to mild steel surfaces compared with untreated cells, for both *Desulfovibrio* and *Pseudomonas* (Tables 3,4 and 5), suggests the presence of attachment-mediating carbohydrates on the outer membranes of these bacterial cells. The results of treatment with lectins and their sugar inhibitors indicate that the carbohydrates involved are glucose (glc) and N-acetylglucosamine (glcNAc) in the case of *P. fluorescens* and a di- or polymeric form of N-acetylglucosamine in the case of *D. desulfuricans* (Tables 4 and 5). Further confirmation of the involvement of glc and glcNAc in the process of attachment of *P. fluorescens* and of glcNAc in the case of *D. desulfuricans* comes from the treatment of the bacterial cells with the enzymes glucosidase and N-acetylglucosaminidase. Both enzymes inhibit adhesion of *Pseudomonas* to mild steel, whereas only N-acetylglucosaminidase significantly decreases the attachment of *Desulfovibrio* compared with untreated controls (Table 6). The saccharide composition of the LPS of these two bacterial strains has not been reported in the literature, although glucose and N-acetylglucosamine are commonly present in LPS of bacteria of the *Pseudomonas* group (Kenne and Lindberg, 1983). For the strains used in this work, gas chromatographic analyses (GC-FID and GC-MS) reveal glucose as a major neutral sugar in *P. fluorescens* LPS (Table 10), while amino sugars are detected colorimetrically in LPS extracted from both *D. desulfuricans* and *P. fluorescens* cells (section 3.3.3).

Although these results indicate that glucose and/or glcNAc are part of bacterial cell surface structures associated with adhesion, they give no information about the type of macromolecule involved. Sugars could be present as either polysaccharide or glycoprotein in the bacterial cell walls. The specific interaction of the LPS of *Desulfovibrio vulgaris* with ferrous ions *in vivo* and in an artificial system has been demonstrated by Bradley et al. (1984) and Bradley and Gaylarde (1988). The site of this interaction has been suggested to be the sugar side chain of *D. vulgaris* LPS (Siew, 1987). Hence, the hypothesis may be proposed that a specific binding between the related species, *Desulfovibrio desulfuricans*, and ferrous ions at metal surfaces could be mediated by polysaccharides in LPS.

Protease treatment, shown by Bradley (1985) to remove a major portion of the outer membrane proteins from *D. vulgaris* (Woolwich), does not reduce adhesion of *D. desulfuricans* or *P. fluorescens* (Table 7), suggesting that attachment-associated molecules are not of a proteinaceous nature. The ability of protease-treated cells to respond to lectins in the same way as untreated cells indicates that the carbohydrate-containing macromolecules involved in attachment are probably not glycoprotein, but polysaccharide or lipopolysaccharide.

Since protease treatment excludes glycoproteins as likely adhesins, the involvement of carbohydrate side-chains of LPS in the attachment process assumes greater importance as a potential mechanism of initial cell adhesion to steel. The adhesion of both *Pseudomonas* and *Desulfovibrio* cells treated with antibodies raised against extracted bacterial LPS (A-LPS) is inhibited by treatment with homologous, but not heterologous, antibodies (Tables 8 and 9), lending support to the suggestion that LPS is involved in the initial attachment processes of these two species.

The inhibition of attachment of *D. desulfuricans* by antibodies raised against LPS of *D. vulgaris* together with slide agglutination tests (sections 3.2.5 and 3.2.4) suggests similarities in the O-antigen composition of these bacteria. This observation is further supported by comparing the composition of neutral sugars detected chromatographically and colorimetrically in LPS of *D. desulfuricans* and *D. vulgaris* (Table 33).

**Table 33: NEUTRAL CARBOHYDRATES DETECTED IN LPS OF *D. DESULFURICANS* AND *D. VULGARIS*.**

Method of detection	Type of sugar	
	<i>D. vulgaris</i> <sup>1</sup>	<i>D. desulfuricans</i> <sup>2</sup>
Chromatography	Glucose (possibly) Rhamnose Galactose N-acetylglucosamine not determined	Glucose Rhamnose Galactose not determined Mannose
Colorimetric assay	not performed	N-acetylaminosugar

<sup>1</sup>Siew (1987)

<sup>2</sup>section 3.3.3

Chromatographic analysis (HPLC) of LPS extracted from *D. vulgaris* reveals N-acetylglucosamine as the major neutral sugar component. Rhamnose, galactose and possibly glucose are also identified (Siew, 1987).

Under the experimental conditions used for GC-FID and GC-MS (sections 2.6.3.5 and 2.6.3.6) the presence of amino sugars in LPS samples of *D. desulfuricans* and *P. fluorescens* could not be detected (the column required was not available). The colorimetric assay of amino sugars can be employed in their detection but is not very reliable for their quantification, since there can be reactions from neutral sugars and amino acids present in the sample producing an interfering colour (Wheat, 1966). Therefore the real amount of

glcNAc in *D. desulfuricans* LPS could well be greater than that estimated colorimetrically and could even exceed that of glucose. If this were so, it would explain the inhibition of adhesion of *D. desulfuricans* cells induced by WGA and not by ConA. Alternatively glucose, although present at a high level in LPS of *D. desulfuricans*, may not participate in attachment of these cells to mild steel because the tertiary structure of the O-side chain causes glucose to be unavailable to the exterior, leaving glcNAc as the only carbohydrate with exposed binding sites.

The lack of effect on adhesion by purified preimmune rabbit serum (Tables 8 and 9) and by some enzymes (section 3.2.3) indicates that the presence of additional protein in the suspending medium has no influence on the attachment of cells to mild steel. This is in contrast to the results reported by Chamberlain (1988) suggesting that proteins alone may inhibit adhesion.

The specificity of A-LPS treatment, in conjunction with lectin and enzyme data, strongly indicates the involvement of the O-antigenic portions of LPS in the initial phase of colonisation of mild steel surfaces by *P. fluorescens* and *D. desulfuricans* cells.

Various studies on attachment of Gram-negative bacteria to "inert" (non-biological) surfaces such as glass, metal or polystyrene have emphasised the role of bacterial outer membrane components in this attachment, suggesting bacterial extracellular polymers (EPS) as potential adhesins (Stanley, 1983; Fattom and Shilo, 1983; Paul and Jeffrey, 1985). Although the participation of EPS in adherence of bacterial cells to solid substrata has been frequently described in the literature it has not been made clear if the initial attachment involves EPS. One report suggesting that this may not be so is that of Pringle et al. (1983). They studied the relationship between adherence of *P. fluorescens* to plastic and EPS production by the cells and showed that adhesion-deficient mutants produce higher levels of EPS than cells with increased attachment ability. They conclude that EPS

may not be concerned with the primary attachment of the cells, but with the development of the subsequent bacterial biofilm.

It may be that reports of EPS involvement in cell adhesion are the result of the use of impure EPS. Chemical analysis of crude bacterial EPS by other workers demonstrated the presence of protein, polysaccharide and DNA (Platt et.al., 1985). However, even the highly purified polymer may contain a portion of the O-antigen side chains of lipopolysaccharides. LPS are accepted to act as cell surface adhesins in the attachment of some pathogenic Gram-negative bacteria to biological surfaces (Petersen and Quie, 1981; Sherman and Soni, 1988), but no work elucidating the role of LPS in adsorption of bacteria to solid "inert" surfaces has been reported prior to this thesis.

The ability of *D. desulfuricans* cells to attach to mild and stainless steel in distilled water to the same extent as in nutrient-rich medium C (section 3.2.1) together with the lack of effect of pre-immune rabbit serum, suggests that in batch cultures the environment has little effect on the initial adhesion of cells to these surfaces. Clearly factors other than ionic strength of the medium are involved. Zaidi et al. (1984) reported selectivity in colonisation of titanium and aluminium surfaces by different strains of bacteria in ambient seawater and suggested that "the origin of this selectivity may lie in the molecular specificity of surfaces for the polymeric adhesion promoting materials found on the surfaces of these microorganisms". The differences in chemical composition of mild and stainless steel used in this work (see Appendix, Table 1A) may be responsible for their differing attractive capacities towards bacterial cells. It is accepted that stainless steel exhibits passivity in aqueous environments and that the passive film is essentially an oxide. The chromium-containing steel used in this work would have an intact and very tenacious chromium (III) oxide ( $\text{Cr}_2\text{O}_3$ ) layer deposited on the surface. This oxide, quite insoluble in aqueous solutions, would provide a protective coating over the surface of stainless steel preventing dissolution of other metal

species such as iron and therefore reducing concentrations of ferrous ions at the solid/liquid interface. No such film covers the surface of mild steel where mainly relatively soluble iron oxides are present. The concentration of ferrous ions would be therefore greater at the MS surface compared with SS surface. The specificity of interaction between bacterial LPS and divalent cations such as ferrous ions (Bradley and Gaylarde, 1988) indicates that the availability of these ions at the surface could be an important factor influencing the quality and quantity of the biofilm formed on these surfaces. Indeed, the low level of the attachment of cells to stainless steel (SS), compared to mild steel (MS) (Table 2), echoed by the smaller quantity of biofilm formed on SS surfaces (Table 12), suggests that the intrinsic chemical properties of the substrate affect bacterial adhesion significantly.

The attachment of bacteria to solid surfaces has generally been regarded as non-specific, involving only physical factors (Fletcher 1980). The identification of the involvement of a specific surface macromolecule such as LPS in bacterial adsorption to mild steel offers new approaches for the discovery of potential inhibitors of microbial fouling.

#### **4.2 BIOFILM FORMATION ON STEEL SURFACES**

Scanning electron microscopy (SEM) studies were undertaken to observe the changes taking place on the mild steel (MS) and stainless steel (SS) surfaces exposed to pure and mixed cultures of *P. fluorescens* and *D. desulfuricans* over a period of time. The surface changes occurred due to attachment of cells to the metal and subsequent colonisation of surfaces resulting in build-up of biofilms. These biofilms contained bacterial cells, exopolymeric substances and corrosion products. Energy dispersive X-ray analysis (EDAX) of biofilms together with chemical analysis aided SEM studies by providing more information about the composition of developed biofilms. Viable counts of sessile cells gave additional information about the bacterial population within biofilms.

In the early phase of biofilm build-up (up to 7 days) no significant difference in the biofilm bulk is detected between the two types of steel regardless of inoculum type (Table 12). However, SEM micrographs demonstrate lower numbers of bacterial cells present on SS surfaces compared with MS surfaces. Although the amount of protein detected colorimetrically in 7 day old biofilms does not differ significantly between the MS and SS surfaces (Table 18), bacterial cells are not the only source of protein in these biofilms. Proteins from the yeast extract which is one of the components of the culture medium may contribute to the total protein content. With time of incubation extended to 28 days the weight of biofilms recovered from MS surfaces is significantly greater than that measured on SS coupons, indicating the importance of substratum in biofilm growth.

The bulk of all types of biofilms formed on MS surfaces estimated by dry weight measurements significantly increases with time (Table 12) indicating that even in batch cultures biofilm development on MS can be regarded as a dynamic process. The quantity of mature, 28 day old biofilm formed on these surfaces by pure cultures of *Desulfovibrio* is significantly greater than that formed by pure and mixed *Pseudomonas* cultures. Since the viable counts of sessile bacteria show equal number of *Desulfovibrio* cells present in mixed and pure biofilms (Table 1) and colorimetric estimation of proteins shows no significant difference between pure and mixed *Desulfovibrio* cultures and since there is significantly more protein than in biofilm from pure *Pseudomonas* cultures (Table 18), the increased biofilm bulk registered in pure *Desulfovibrio* cultures could be due to iron sulphides. EDAX analysis (Table 19) shows the presence of large amounts of sulphur on MS surfaces exposed to actively growing pure and mixed cultures of *Desulfovibrio*. Much smaller amounts of sulphur are registered on surfaces incubated in uninoculated medium C (control surfaces) and those exposed to *P. fluorescens* only. Less sulphur is present on MS incubated in mixed than in pure *Desulfovibrio* cultures. This suggests that the accumulation



of iron sulphides on MS incubated with *Desulfovibrio* could be greater on surfaces exposed to pure cultures of these bacteria than on those incubated with mixed cultures.

The significant increase in the volume of biofilm on SS coupons in pure *Desulfovibrio* cultures with time can be attributed to increases in the level of the cell metabolic products. EDAX analysis does not show any great variation in the level of sulphur and thus excludes ferrous sulphides as the ingredients responsible for the increase in biofilm bulk. However, significantly more protein is detected in these biofilms with prolonged incubation although the number of cells visible under SEM at different time intervals does not seem to differ. Together with EDAX data showing a great decrease in detectable iron this could indicate that the material derived from cell metabolism and cell lysis could contribute to mature *Desulfovibrio* biofilms on SS surfaces.

The MS surfaces exposed to *P. fluorescens* do not accumulate large quantities of biofilm compared with surfaces incubated with *Desulfovibrio* (Plates 29 and 32 respectively). The amount of iron detected by EDAX on the MS exposed to *Pseudomonas* exceeds that on surfaces exposed to *Desulfovibrio* by 4-fold after 16 days of incubation, but begins to decrease with prolonged time of exposure up to 21 days, suggesting a build-up of some type of surface deposit. SEM micrographs show that a thin oxide-hydroxide layer covers these surfaces and reveal the presence of clumps of lenticular crystals (Plates 29, 30a and 31a) which are morphologically similar to haematite. The presence of these crystals on uninoculated MS surfaces (Plate 38a) indicates that they are the product of mild steel oxidation in medium C. The absence of the crystals on MS surfaces incubated with pure and mixed *Desulfovibrio* supports this conclusion since the anaerobic conditions created by these bacteria would prevent the formation of iron oxides. In mixed biofilms *Pseudomonas* cells are present in low numbers compared with pure cultures (Table 1) and on SEM micrographs the cells are usually seen associated with the biofilm uppermost layer

(Plate 37b). This suggests that the highly anaerobic conditions created by the presence of sulphate reducers (SRB) inhibit the metabolism of *P. fluorescens* impeding their growth. There is no significant increase in dry weight of biofilms grown in pure and mixed *Pseudomonas* cultures on SS surfaces with prolonged incubation from 7 to 28 days. The protein level in these cultures does not significantly increase with time and EDAX analysis shows that on surfaces incubated with pure *Pseudomonas* the amount of iron detected does not show any great variation when monitored over 21 days. No crystal accumulation can be seen on surfaces exposed to pure *Pseudomonas* cultures, thus indicating that stainless steel does not oxidise in medium C to the extent of MS. The chromium oxide layer on SS coupons will prevent the formation of iron oxides.

The much poorer development of biofilm on SS than on MS surfaces by pure and mixed bacterial cultures with time suggests that a different mechanism can be involved in the process of biofilm growth on these surfaces. It has been reported that surface texture can affect the rate of bacterial colonisation (Baker, 1984). In these experiments mild and stainless steel surfaces were given the same surface finish resulting in considerable surface roughness. SEM observations of these surfaces reveal that bacteria do not selectively colonise cavities and grooves. There are however significant differences in biofilm quantities on the two types of steel. This could therefore indicate that factors influencing initial adhesion of bacteria to these surfaces may continue to be important regulators of biofilm development. The availability of free metal ions with which cells can selectively interact (by means of either LPS or cell bound EPS) and the effect of these ions on the cells' metabolic processes (including production of exopolymers) are such potential regulatory mechanisms.

Chemical analysis of *P. fluorescens* and *D. desulfuricans* biofilms performed colorimetrically and by gas chromatography (GC-MS and GC-FID) shows that they

contain exopolysaccharides. The presence of extracellular polysaccharides in biofilms of *D. desulfuricans* has not previously been reported in the literature. In fact the majority of studies on bacterial polysaccharides are concerned with the analysis of polymers harvested from the bulk phase and very little is known of the composition of carbohydrates associated with the surfaces to which cells adhere.

This investigation reveals the ability of both *Pseudomonas* and *Desulfovibrio* to produce polysaccharides in biofilms formed on mild and stainless steel and demonstrates the influence of substratum on carbohydrate production. Under identical cultural conditions significantly less neutral sugars are detected colorimetrically in *Desulfovibrio* biofilms on SS than on MS surfaces (Table 13) irrespective of the incubation time. No such specificity of cell/surface interaction is noticed in *P. fluorescens* biofilms, suggesting that exopolysaccharide production by these bacteria may not be substratum-influenced.

It is evident that steel surfaces do not stimulate exopolymer production by *Pseudomonas* cells. The concentration of neutral hexoses and uronic acids (Tables 13 and 14) detected in *Pseudomonas* biofilms is lower than that measured in *D. desulfuricans* biofilms under all experimental conditions and SEM micrographs clearly show very small amounts of exopolymer (visualised as threads connecting cells with the surface) associated with *Pseudomonas* biofilms (Plate 5a) compared with *Desulfovibrio* biofilms (Plate 5b). This observation is supported by the fact that the levels of free EPS precipitated from *Pseudomonas* cultures do not vary significantly between coupon-containing and coupon-free samples (Table 20). The presence of steel coupons in the cultures of SRB stimulates the production of free EPS by the cells (Table 20) suggesting the influence of surfaces (possibly acting as an additional iron source) on *Desulfovibrio* metabolism.

Although quantities of neutral carbohydrates present in biofilms differ significantly between the two bacterial species, the major neutral carbohydrates detected in biofilms formed by

pure and mixed bacterial cultures on MS surfaces are identical. Glucose, mannose and galactose are detected in all analysed biofilm samples (Table 15). However, molar ratios between sugars differ depending on inoculum type as summarised in Table 34.

**Table 34: MOLAR RATIOS BETWEEN MAJOR NEUTRAL CARBOHYDRATES DETECTED IN 7 DAY OLD BIOFILMS FORMED ON MS COUPONS BY PURE AND MIXED CULTURES OF *P. FLUORESCENS* AND *D. DESULFURICANS***

Inoculum type	Neutral sugar ratios		
	Glucose	Galactose	Mannose
<i>P. fluorescens</i>	1	0.1	0.5
<i>D. desulfuricans</i>	1	0.65	0.7
<i>P. fluorescens</i> and <i>D. desulfuricans</i>	1	0.4	1.1

The difference in molar ratio between glucose and galactose could be used as an indicator in analysing population dynamics within mixed biofilms. A change in this ratio would suggest a shift in the population of bacterial species.

The evidence that the carbohydrates detected in bacterial biofilms originate from exopolymers elaborated by the cells comes from the fact that the exopolymers can also be recovered from the culture media. The proteinaceous content of free exopolymers is confirmed by colorimetric assay (Table 31) and by SDS-gel electrophoresis (section 3.5.5.2) and their neutral carbohydrate content is estimated colorimetrically and chromatographically (sections 3.5.2 and 3.5.3). The neutral sugar composition of free polysaccharides harvested from the bacterial culture media incubated with MS surfaces differs from that recovered from the respective biofilms (Tables 15, 24, 25 and 26). Uronic acids detected in these biofilms are not found in the corresponding free EPS samples. The type of surface to which bacteria are exposed influences composition and quantity of neutral sugars present in free exopolymers secreted by the cells and this again emphasises the specificity in the response of bacterial cells to the substratum. Although not proven, it

has been suggested that the sugar composition of bacterial exopolymer produced on the surface is identical to that found in the liquid phase of the incubating medium (Kennedy and Sutherland, 1987). These results clearly show that in batch cultures, in the presence of mild steel surfaces, the polysaccharides released into the media by pure and mixed cultures of bacteria of the genus *Pseudomonas* and *Desulfovibrio* are not identical with the polysaccharides detected in biofilms formed by these bacteria on mild steel.

Mannose is the major neutral carbohydrate component found in all types of free bacterial exopolysaccharides in this study and is one of the major sugars in biofilm exopolymers. Since lectin experiments exclude mannose as a potential surface adhesin, it is unlikely that the polysaccharides present in free or biofilm EPS participate in the early stages of bacterial attachment to mild steel.

#### 4.3 CORROSION OF STEEL IN BACTERIAL CULTURES

Scanning electron microscopy and kinetic polarisation measurements undertaken to study the corrosion of steel in pure and mixed batch cultures of *P. fluorescens* and *D. desulfuricans* show that in the presence of bacteria corrosion of mild steel increases compared with surfaces incubated in uninoculated growth medium.

Increase of corrodibility of MS coupons in pure *Desulfovibrio* cultures with time is shown by cathodic polarisation curves. Occurrence of pitting on these surfaces demonstrated by the multitude of passive-active transitions on the anodic curves (Figure 12) is confirmed by SEM observations. The micrographs show severe surface damage in the form of extensive pitting under *Desulfovibrio* biofilms (Plates 39a,b). It is reported in the literature that sulphides produced by bacterial cell metabolism may form a protective or an aggressive film on the metal surface (Tiller, 1983) and that ferrous sulphide films usually inhibit corrosion but upon their break-up the corrosion may increase (Iverson and Olson, 1983).

The EDAX analyses performed in this study indicate the accumulation of large amounts of ferrous sulphides on MS surfaces exposed to *Desulfovibrio*. It seems likely that under the experimental conditions described in this study the non-tenacious, easily disturbed sulphide films formed on MS surfaces by *Desulfovibrio* exhibit aggressive characteristics and are the main cause of mild steel corrosion in SRB cultures. The role of the ferrous sulphide film in corrosion of mild steel is further confirmed by the reduced degree of corrosion observed on these surfaces in mixed SRB cultures compared with pure *Desulfovibrio* cultures. Although the weight of pure culture biofilm removed from MS coupons does not differ significantly from that recovered from mixed cultures, lower amounts of ferrous sulphides accumulate on mild steel colonised by mixed *Desulfovibrio* cultures compared with pure cultures. Previous reports have shown increased corrosion in mixed cultures of *Vibrio* spp. (a facultative anaerobe) and SRB (Gaylarde and Johnson, 1982; Gaylarde and Videla, 1987). However, no assessments of sulphide levels were attempted. A suggested explanation of the increased corrosion in mixed cultures was the removal by *Vibrio* of a passive layer from the metal surface. It may be that *Pseudomonas*, an obligate aerobe, is not capable of sufficient metabolic activity under the anaerobic conditions created in these experiments for such an effect to occur.

It has been suggested that the corrosive activity of SRB is due to the production of highly corrosive reduced phosphorus compounds (Iverson, 1987). The EDAX analyses reveal the presence of phosphorus on steel surfaces exposed to *Desulfovibrio*, but the amount of this element is greater on control (medium C only) surfaces at all times of incubation (Table 19). It seems unlikely that the film formed on mild steel incubated with *Desulfovibrio* contains quantities of phosphorus which could induce a greater degree of corrosion of these surfaces than that attributed to the properties of medium C alone, although it could be the species of phosphorus compound and not the concentration of the element itself which exhibits corrosive properties.

The corrosion of mild steel exposed to pure cultures of *P. fluorescens* differs from the damage observed on surfaces exposed to SRB. Anodic polarisation curves do not show many passive-active transitions indicative of pit formation and no pitting potential values are apparent on these curves. The lack of pitting is demonstrated by SEM. The micrographs show surfaces covered with a thin layer of oxide/hydroxide film and an accumulation of haematite crystals with time. Natural splitting of the surface coating or its removal with Clark's solution reveals a certain degree of metal corrosion (Plates 31b,c and 41a,b ) but not in the form of large pits such as the type appearing under SRB biofilms (Plates 40a,b). The slight anodic passivation of mild steel with time noticed during polarisation measurements (Figure 11) may be indicative of an oxide build-up and increase in crystal formation. The role of haematite crystals in corrosion of these surfaces is not clear. As suggested earlier in this chapter the crystals are probably products of mild steel oxidation in culture medium since they also appear on surfaces exposed to uninoculated medium (controls). Moreno et al. (1990) found that on MS surfaces incubated for 30 days with *P. fluorescens* corroded areas corresponded with the shape of crystalline clumps but no such areas of corrosion were found on control surfaces. *Pseudomonas* cells accumulated on and around crystals may therefore be involved in etching of the mild steel and the metabolic products of bacterial cells trapped beneath crystals could be the corrosive agent.

Polarisation studies and SEM and EDAX analyses reveal that the degree of corrosion of stainless steel is not enhanced in bacterial cultures to any great extent compared with uninoculated media. This would indicate that the passivity of SS due to the presence of the chromium oxide layer is generally unaffected by bacteria and their metabolic products under these experimental conditions. However, some indication of pit initiation on surfaces incubated in pure and mixed SRB cultures is given by the presence of a few passive-active

transitions visible on anodic curves (Figures 17 and 19), suggesting that the breakdown or dissolution of the protective oxide film may occur with time.

The presence of *Pseudomonas* does not seem to have any damaging effect on the passive film. On the contrary, from the shape of the anodic polarisation curves (Figure 18) it appears that stabilisation of this film occurs in *Pseudomonas* cultures with time. A similar protective effect of some bacterial species on steel has been noted by other workers (Gaylarde and Johnston, 1986).

When analysing the role of bacterial biofilms in the corrosion of metal surfaces the involvement of bacterial exopolymers must be considered. The role of bacterial exopolymers in selective binding of metal ions is well documented in the literature; however there is some ambiguity concerning identification of the moiety involved in interaction of these polymers with metals. Some authors suggest the likely involvement of proteins (Ford et al., 1987; Angell and Chamberlain, 1991), others stress the importance of polysaccharides, especially charged carboxylic acid residues of uronic acids, in metal/polymer interaction (Mittelman and Geesey, 1985; Brown and Lester, 1979). Regardless of the type of mechanism involved, the role of bacterial EPS in metal corrosion is undisputable.

Polysaccharides present in surface-associated exopolymers of some *Pseudomonas* species are shown to enhance the corrosion of metals (White et al., 1986; Jolley et al., 1990). Exopolymers of the genus *Desulfovibrio* and their importance in corrosion of metals have not yet been studied. These experiments offer no direct proof of the role of biofilm-bound exopolymers produced by *Desulfovibrio* and *Pseudomonas* species in corrosion of steel but some theoretical considerations may be assessed. SEM observations reveal various levels in EPS abundance depending on cultural conditions. Chemical analyses of the biofilm-associated EPS show that they contain neutral and acidic polysaccharides and proteins. It



is quite possible that the exopolymers provide an additional corrosion mechanism via electrostatic bonding between hydroxyl groups of carbohydrates and metal cations. However, these interactions are relatively weak and it is therefore unlikely that EPS are of paramount importance in corrosion of steel in pure and mixed cultures of *P. fluorescens* and *D. desulfuricans*. This conclusion is supported by the fact that although no significant difference is recorded between the amount of neutral sugars detected in pure and mixed biofilms formed by *Desulfovibrio* on MS surfaces and the uronic acid content in both types of biofilms is comparable, yet the corrosion caused by pure SRB cultures is greater than that observed in mixed cultures.

Environmental conditions such as pH or the amount of exopolymers released into the liquid phase do not seem to have any influence on the corrosion behaviour of steel under the experimental conditions chosen in this study. The pH values of the incubating media vary between 7 and 8 with the exception of mixed SRB cultures (Table 32). The pitting potential values measured on anodic polarisation curves (Figures 15 and 16) indicate that the mixed culture environment is less aggressive than the environment created by pure *Desulfovibrio* cultures. Gaylarde and Videla (1989) reported that for mild steel, the changes in pH values of sterile medium C between 7 and 8 do not greatly influence the values of pitting potentials thus it is assumed that the variation in pH values is unimportant when studying corrosion occurring in batch cultures employed in this investigation. Analyses of the experimental data also show that levels of free EPS present in the culture media do not influence the corrosion. SEM studies and kinetic polarisation studies reveal that little corrosion occurs on mild steel incubated with *P. fluorescens* cultures compared with the degree of corrosion observed in pure and mixed *Desulfovibrio* cultures, yet the highest level of free EPS is found in pure *Pseudomonas* cultures. The amount of free exopolymer precipitated from SS containing cultures is not significantly different from the quantity harvested from the cultures grown in the presence of MS coupons (Table 27) but the

corrosion of the mild steel is very pronounced, whilst no obvious signs of corrosion are detected on stainless steel surfaces.

It must now be unequivocally accepted that bacterial metal corrosion is a function of cells and their metabolites present in biofilms on the metal surfaces. The results of this investigation confirm that the formation of bacterial biofilms on the surfaces of mild and stainless steel is the main factor involved in corrosion and that the EPS released to the bulk phase of the culture medium do not appear to participate in it. The role of the biofilm-bound exopolymers in the corrosion is not explicit. The carbohydrate or protein components of biofilm-bound EPS may provide additional corrosion mechanisms but oxides and sulphides seem to be the main factors responsible for deterioration of mild steel in bacterial cultures whilst the passive oxide layer protects stainless steel from corrosion under batch culture conditions.

#### 4.4 CONCLUSIONS

This investigation demonstrates the process of biofilm formation on steel surfaces by pure and mixed cultures of *D. desulfuricans* and *P. fluorescens* and illustrates the role of bacterial biofilms in corrosion. Early attachment of cells to mild steel is shown to involve carbohydrates present in O-antigenic fractions of bacterial LPS. Interaction of ferrous ions with glucose and N-acetylglucosamine in the case of *Pseudomonas* and a polymeric form of N-acetylglucosamine in the case of *Desulfovibrio* is believed to be an important mechanism involved in the first stage of biofilm development. The availability of ferrous ions at a surface/liquid interface would influence attachment of bacterial cells to steel. A passive layer of chromium oxide on SS decreases the concentration of ferrous ions at these surfaces thus making them less accessible to cells. Mild steel surfaces provide a rich source of these ions. This proposed model of cell/surface interaction explains differences in cell adhesion observed between MS and SS surfaces.

The interaction between ferrous ions and carbohydrates from bacterial LPS may also continue to play a role in influencing subsequent surface colonisation. SEM observations show that mild steel surfaces in *Desulfovibrio* cultures develop thick biofilms whereas exposure of MS to *Pseudomonas* results in scanty, monolayer surface coverage. The thin oxide layer appearing on MS in the latter cultures prevents dissolution of iron from steel thus reducing the concentration of ferrous ions on the surface. No such oxide film builds up on MS in *Desulfovibrio* cultures due to the anaerobic environment created by SRB. On SS surfaces insoluble chromium oxide continues to protect the iron from dissolution therefore limiting binding sites for LPS and restricting colonisation of SS.

The ability of both bacterial species to produce exopolymers is demonstrated by SEM. Exopolymers produced by bacteria in biofilms and those released into the liquid phase are not identical. Their neutral carbohydrate composition differs and only biofilm-bound EPS contain uronic acids. Mannose is the major sugar present in all types of free EPS and is one of the main carbohydrates detected in biofilm-bound EPS. Since mannose is shown by lectin studies not to participate in initial attachment of cells, it is unlikely that EPS are involved in early adhesion. The highest levels of free EPS recovered from *Pseudomonas* cultures, the organism forming the scantiest biofilm on MS surfaces, and the lack of significant difference between quantities of EPS harvested from bacterial cultures containing MS and SS further supports this view. The presence of steel surfaces stimulates free EPS production in *Desulfovibrio* cultures indicating the influence of substratum presence on bacterial metabolism. It may be that steel provides an additional iron source, thus promoting SRB activity. The enhanced growth of SRB in the presence of steel coupons has also been observed by other workers (Siew, Gaylarde, personal communications). *Pseudomonas* does not respond to the presence of steel surfaces in this way.

The corrosion of MS, observed as extensive surface pitting, increases in the presence of bacteria, reaching its highest degree in *Desulfovibrio* cultures. The main factor involved in deterioration of MS in these cultures is the presence of ferrous sulphides. Pure *Desulfovibrio* biofilms contain the highest level of these products, as indicated by EDAX, and polarisation curves and SEM show that MS in these cultures exhibits the highest degree of pitting. Neutral carbohydrates and uronic acids present in the abundant EPS associated with SRB biofilms may help steel deterioration by providing additional corrosion mechanisms (metal chelation, galvanic coupling), but in these experiments EPS do not seem to play a major part in SRB-induced corrosion of MS. MS surfaces exposed to *Pseudomonas* show some degree of corrosion but no pitting. The amount of EPS present in these biofilms is very small and they contain lower amounts of neutral carbohydrates and uronic acids compared with EPS of *Desulfovibrio*. The corrosive action of cell metabolic products (and this would include EPS) trapped under the oxide-hydroxide layer and haematite crystals (products of MS oxidation in an aqueous aerobic environment) is believed to be the main corrosion mechanism for *Pseudomonas*. The free EPS are deemed unlikely to participate in corrosion since there is no correlation between their levels and the extent of damage observed.

The chemistry of the steel seems to be an important factor in its corrosion. In spite of the identical physical surface finish the degree of corrosion between MS and SS varies considerably.

These experiments show the specificity of interaction between mild and stainless steel and bacteria from the genus *Pseudomonas* and *Desulfovibrio* by elucidating the role of bacterial surface molecules such as LPS and EPS in the formation of biofilms and demonstrate the importance of intrinsic properties of a surface in bacterially-induced corrosion of steel.

#### **4.5 RECOMENDATIONS FOR FUTURE WORK**

In view of the results obtained in this investigation further work elucidating biofilm formation on steel surfaces and its role in corrosion could include:

- (i) More detailed chromatographical analysis of bacterial LPS to characterise their amino sugar and uronic acid composition. This would help in establishing more firmly the role of these molecules in the initial attachment of *Desulfovibrio* and *Pseudomonas* to mild steel. Competitive binding studies, using pure sugar samples, might also be employed.
- (ii) Raising monoclonal antibodies against bacterial LPS and EPS to achieve greater specificity when studying inhibition of bacterial attachment to mild steel. The antibodies could also be used to establish the location of the molecules within the outer membranes by ferritin labelling and transmission electron microscopy.
- (iii) Studying binding of ferrous ions and chromium ions by LPS and EPS to elucidate differences observed in bacterial attachment, colonisation and corrosion between mild and stainless steel.
- (iv) Further purification of biofilm-bound exopolymers and study of their impact on corrosion of mild and stainless steel by experimental methods similar to that of Jolley et al. 1990. The investigation of the effect of treatment of impure exopolymers with various enzymes prior to metal binding studies could also be undertaken.

## **BIBLIOGRAPHY**

- Abbot, A., P.R. Rutter and R.C.W. Berkeley. 1983. The influence of ionic strength, pH and protein layer on the interaction between *Streptococcus* mutants and glass surfaces. *Journal of General Microbiology* **35**, 299-324.
- Absolom, D.R., F.V. Lamberti, Z. Policova, W. Zing, C.J. van Oss and W. Neumann. 1983. Surface thermodynamics of bacterial adhesion. *Applied and Environmental Microbiology* **46**, 90-97.
- Aftring, P.P. and B.F. Taylor. 1979. Assessment of microbial fouling in an ocean thermal energy conversion experiment. *Applied and Environmental Microbiology* **38**, 734-739.
- Angell, P. and A.H.L. Chamberlain. 1991. Roles of extracellular products in copper colonisation. *International Biodeterioration*. In press.
- Baier, R.E. 1980. Substrata influences on adhesion of microorganisms and their resultant new surface properties. In: Adsorption of microorganisms to surfaces, (G. Bitton and K.C. Marshall, eds.), Wiley-Interscience, New York, 59-104.
- Baker, J.H. 1984. Factors affecting the bacterial colonisation of various surfaces in a river. *Canadian Journal of Microbiology* **30**, 511-515.
- Bakke, R., W.G. Characklis, M.H. Turakhia and A-I. Yek. 1988. Modelling a monopopulation biofilm system: *Pseudomonas aeruginosa*. In: Biofilms, (W.G. Characklis and K.C. Marshall, eds.), John Willey and Sons, New York.
- Berk, S.G., R. Mitchell, R.J. Bobbie, J.S. Nickels and D.C. White. 1981. Microfouling of metal surfaces exposed to seawater. *International Biodeterioration Bulletin* **17**, 29-35.
- Bessems, E. 1983. Biological aspects of the assessment of biocides. In: *Microbial Corrosion*, The Metals Society, London, 84-89.
- Blumenkrantz, N. and G. Asboe-Hansen. 1973. New method for quantitative determination of uronic acids. *Analytical Biochemistry* **54**, 484-489.
- Booth, G.H. and A.K. Tiller. 1962. Polarisation studies of mild steel in cultures of sulfate reducing bacteria. *Transactions of the Faraday Society* **58**, 2510-2516.
- Booth, G.A., A.W. Cooper and P.M. Cooper. 1967. Rates of microbial corrosion in continuous culture. *Chemistry and Industry* **49**, 2084-2085.
- Booth, G.H., L. Elford and D.S. Wakerly. 1968. Corrosion of mild steel by sulfate reducing bacteria: an alternative mechanism. *British Corrosion Journal* **3**, 242-245.
- Bos, P. and J.G. Kuenen. 1983. Microbiology of sulphur-oxidising bacteria. In: *Microbial Corrosion*, The Metals Society, London, 18-27.
- Boyle, C.D. and A.R. Read. 1983. Characterisation of two extracellular polysaccharides from marine bacteria. *Applied and Environmental Microbiology* **46**, 392-399.
- Bradley, G., C.C. Gaylarde and J.M. Johnston. 1984. A specific interaction between ferrous ions and lipopolysaccharides in *D. vulgaris*. *Journal of General Microbiology* **130**, 441-444.

- Bradley, G. 1985. An investigation into the structure and functional aspects of the cell wall of *Desulfovibrio*. PhD. thesis, City of London Polytechnic.
- Bradley, G. and C.C Gaylarde. 1988. Iron uptake by *D.vulgaris* outer membrane components in artificial vesicles. *Current Microbiology* 17, 189-192.
- Bridsell, D.C., R.J. Doyle and M. Morgenstern. 1975. Organisation of teichoic acid in the cell wall of *Bacillus subtilis*. *Journal of Bacteriology* 121, 726-734.
- Bright, J.J. and M. Fletcher. 1983a. Amino acid assimilation and electron transport system activity in attached and free living marine bacteria. *Applied and Environmental Microbiology* 45, 818-825.
- Bright, J.J. and M. Fletcher. 1983b. Amino acid assimilation and respiration by attached and free living populations of a marine *Pseudomonas* spp. *Microbial Ecology* 9, 215-226.
- Brown, C.M., D.C. Ellwood and J.R. Hunter. 1977. Growth of bacteria at surfaces. Influence of nutrient limitation. *FEMS Microbiological Letters* 1, 163-166.
- Brown, M.J. and J.N. Lester. 1979. Metal removal in activated sludge: the role of bacterial extracellular polymers. *Water research* 13, 817-837.
- Brown, M.J. and J.N. Lester. 1982. Role of bacterial extracellular polymers in metal uptake in pure bacterial cultures and activated sludge. I. Effects of metal concentration. *Water Research* 16, 1539-1548.
- Burnes, J.M., E.E. Staffeld and O.H. Calderon. 1967. Corrosion caused by organic acids reacting with three metals, with special emphasis on Krebs cycle acids. *Developments in Industrial Microbiology* 8, 327-334.
- Chamberlain, A.H.L. 1988. Summary of discussion. In: *Microbial corrosion-1*, (C.A.C. Sequeira and A.K. Tiller, eds.), Elsevier Applied Science, 447.
- Chaplin, M.F. and J.F. Kennedy. 1986. Elson-Morgan assay. In: *Carbohydrate analyses, a practical approach*, (M.F. Chaplin, and J.F. Kennedy eds.), New York, IRL Press Ltd.
- Characklis, W.G. and K.E. Cooksey. 1983. Biofilms and microbial fouling. *Advances in Applied Microbiology* 29, 93-139.
- Characklis, W.G., Z. Lewandowski, W. Lee and B.J. Little. 1988. Microbial alteration of the metal water interface: Dissolved oxygen and pH microelectrode measurements. *Corrosion* 88, paper No.93, NACE, Houston.
- Chatelus, C., P. Carrier, P. Saignes, M.F. Liberty, Y. Berlier, P.A. Lespinan, G. Fauque and J. Legall. 1987. Hydrogenase activity in aged, nonviable *Desulfovibrio vulgaris* cultures and its significance in anaerobic biocorrosion. *Applied and Environmental Microbiology* 53, 1708-1710.
- Chen, J-R., S-D. Chyou, S-I. Lew, C-J. Huang, C-S. Fang and W-S. Tse. 1988. Investigation of the biological corrosion of condenser tubes by scanning Auger microprobe techniques. *Applied Surface Science* 33/34, 212-219.



- Christensen, B.E., J. Kjosbakken and O. Smidsrod. 1985. Partial chemical and physical characterisation of two extracellular polysaccharides produced by marine, periphytic *Pseudomonas* sp. strain NCMB 2021. *Applied and Environmental Microbiology* **50**, 837-845.
- Cord-Ruwisch, R. and F. Widell. 1986. Corroding iron as a hydrogen source for sulphate reduction in growing cultures of sulphate-reducing bacteria. *Applied Microbiology and Biotechnology* **25**, 169-174.
- Corpe, W. 1970. An acid polysaccharide produced by a primary film forming bacterium. *Developments in Industrial Microbiology* **11**, 402-412.
- Costello, J.A. 1974. Cathodic depolarisation by sulphate reducing bacteria. *South African Journal of Science* **70**, 202-208.
- Costerton, J.W., R.T. Irvin and K-J. Cheng. 1981. The bacterial glycocalyx in nature and disease. *Annual Review of Microbiology* **35**, 299-324.
- Costerton, J.W. and T.J. Marrie. 1983. The role of the bacterial glycocalyx in resistance to antimicrobial agents. In: *Medical Microbiology* vol.3 (C.S.F. Easmon, J. Jellaszewich, M.R.W. Brown and P.A. Lambert ed.), Academic Press, New York, 63-85.
- Costerton, J.W., T.J. Marrie and K-J. Cheng. 1985. Phenomena of bacterial adhesion. In: *Bacterial Adhesion* (D.C. Sauge, M. Fletcher ed.), Plenum Press, New York and London, 3-43.
- Dahlback, B., M. Hermansson, S. Kjelleberg and B. Norkrans. 1981. The hydrophobicity of bacteria, an important factor in their initial adhesion at the air-water interface. *Archives of Microbiology* **128**, 267-270.
- Daniel, M.D. and L.S. Todd. 1975. The species distribution of three Concanavalin A-purified Mycobacterial polysaccharides. *American Review of Respiratory Diseases* **112**, 361-370.
- Dazzo, F.B. 1980. Adsorption of microorganisms to roots and other plant surfaces. In: *Adsorption of microorganisms to surfaces* (G. Bitton and K. Marshall ed.), John Wiley & Sons Inc., New York, 253-316.
- de Pamphilis, M.L. 1971. Dissociation and reassembly of *E. coli* outer membrane and lipopolysaccharide: their assembly onto flagellar basal bodies. *Journal of Bacteriology* **105**, 1984-1999.
- Dexter, S.C. and G.Y. Yao. 1987. Effect of seawater biofilms on corrosion potential and oxygen reduction of stainless steel. *Proceedings of National Association of Corrosion Engineers, Corrosion 87*, Paper No. 3772, NACE, Houston.
- Dowling, N.J.E., F. Widdel and D.C. White. 1986. Phospholipid ester-linked fatty acid biomarkers of acetate-oxidizing sulphate-reducers and other sulphide-forming bacteria. *Journal of General Microbiology* **132**, 1815-1825.

- Dowling, N.J.E., J. Guezennec and D.C. White. 1987. Facilitation of corrosion of stainless steel exposed to aerobic seawater by microbial biofilms containing both facultative and absolute anaerobes. In: *Microbial problems of in the offshore oil industry*, (E.C. Hill, J.L. Shennan and R.J. Watkinson, eds.), John Wiley and Sons Ltd., Chichester, England, 27-38.
- Dowling, N.J.E., J. Guezennec, M.L. Lemoine, A. Tunlid and D.C. White. 1988. Analysis of carbon steels affected by bacteria using electrochemical impedance and DC techniques. *Corrosion* 44, 869-874.
- Dubois, M., K.A. Gilles, J.K. Hamilton, P.A. Rebers and F. Smith. 1956. Colorimetric method for determination of sugars and related substances. *Analytical Chemistry* 28, 349-356.
- Duddridge, J.E. and A.M. Pritchard. 1983. Factors affecting the adhesion of bacteria to surfaces. In: *Microbial Corrosion*, The Metals Society, London, 28-35.
- Dudman, W.F. 1977. The role of surface polysaccharides in environment. In: *Surface carbohydrates of the prokaryotic cell*, (I. Sutherland ed.), Academic Press Inc., New York, 357-414.
- Edyvean, R.G.J. and L.A. Terry. 1983. Polarisation studies of 50D steel in cultures of marine algae. *International Biodeterioration Bulletin* 19, 1-11.
- Edyvean, R.G.J. 1987. Biodeterioration problems of North Sea oil and gas production - a review. *International Biodeterioration* 23, 199-231.
- Elson, L.A. and W.T.J. Morgan. 1933. A colorimetric method for the determination of glucosamine and chondrosamine. *Biochemical Journal* 27, 1824-1828.
- Engel, L. and M. Klingele (eds.). 1981. *An atlas of metal damage*, Wolfe Science Books in association with Carl Manser Verlag, Munich, Vienna.
- Fattom, A. and M. Shilo. 1984. Hydrophobicity as an adhesion mechanism of benthic cyanobacteria. *Applied and Environmental Microbiology* 47, 135-143.
- Fazio, S.A., D.J. Uhlinger, J.H. Parker and D.C. White. 1982. Estimations of uronic acids as quantitative measures of extracellular and cell wall polysaccharide polymers from environmental samples. *Applied and Environmental Microbiology* 43, 1151-1159.
- Filip, C., G. Fletcher, J.L. Wulf and C.F. Earhart. 1975. Solubilisation of the cytoplasmic membrane of *E. coli* by the ionic detergent sodium lauroyl sarcosinate. *Journal of Bacteriology* 115, 717-722.
- Fisher, W., I. Hanssel and H.H. Paradies. 1988. First results of microbial induced corrosion of copper pipes. In: *Microbial Corrosion 1*, (C.A.L. Sequeira and A.K. Tiller, eds.), Barking, Essex, Elsevier Applied Science, 300-327.
- Fletcher, M. and G.D. Floodgate. 1973. An electron microscopic demonstration of an acidic polysaccharide involved in the adhesion of a marine bacterium to solid surfaces. *Journal of General Microbiology* 74, 325-334.

- Fletcher, M. 1976. The effects of proteins on bacterial attachment to polystyrene. *Journal of General Microbiology* 94, 400-404.
- Fletcher, M. 1977. The effect of culture concentration and age, time and temperature on bacterial attachment to polystyrene. *Canadian Journal of Microbiology* 23, 1-6.
- Fletcher, M. and G.I. Loeb. 1979. Influence of substratum characteristic on the attachment of a marine *Pseudomonas* to solid surfaces. *Applied and Environmental Microbiology* 37, 67-72.
- Fletcher, M. 1980. The question of passive versus active attachment mechanisms in non-specific bacterial adhesion. In: *Microbial adhesion to surfaces*, (R.C.W. Berkeley, J.M. Lynch, J. Melling, P.R. Rutter and B. Vincent, eds.), Chichester, Ellis Horwood, 197-210.
- Fletcher, M. and K.C. Marshall. 1982. Bubble contact angle method for evaluating substratum interfacial characteristics and its relevance to bacterial attachment. *Applied and Environmental Microbiology* 44, 193-197.
- Fletcher, M. 1986. Measurement of glucose utilisation by *Pseudomonas fluorescens* that are free living and that are attached to surfaces. *Applied and Environmental Microbiology* 44, 929-937.
- Ford, T.E., J.S. Maki and R. Mitchell. 1987. Metal binding bacterial exopolymers and corrosion processes. *Corrosion* 87, paper 380, NACE, Houston.
- Ford, T.E., J.S. Maki and R. Mitchell. 1988. Involvement of bacterial exopolymers in biodeterioration of metals. In: *Biodeterioration 7, Proceedings of the 7th International Biodeterioration Symposium, Cambridge 1987*, (D.R. Houghton, R.N. Smith and H.O.W. Egging, eds.), Barking, Essex, Elsevier Applied Science, 378-384.
- Galanos, C., O. Luderitz, E.T. Retschel and O. Westphal. 1977. Newer aspects of the chemistry and biology of bacterial lipopolysaccharides, with special reference to their lipid A component. *International Review of Biochemistry* 14, 239-336.
- Gallagher, J.T., M. Harding and R.E. Dale. 1983. Sialic acid as a cell surface binding site for wheat germ agglutinin. In: *Lectins vol.3* (T.C. Bog-Hansen and G.M. Spengler ed.), Walter de Gruyter and Co. Berlin, N. York.
- Gaylarde, C.C. and J.M. Johnston. 1980. The importance of microbial adhesion in anaerobic metal corrosion. In: *Microbial adhesion to surfaces*. (R.C.W. Berkeley, J.M. Lynch, J. Melling, P.R. Rutter, and B. Vincent eds.), Ellis Horwood, Chichester, 511-513.
- Gaylarde, C.C. and J.M. Johnston. 1982. The effect of *Vibrio anguillarum* on anaerobic metal corrosion induced by *Desulfovibrio vulgaris*. *International Biodeterioration Bulletin* 18, 111-116.
- Gaylarde, C.C. and J.M. Johnston. 1986. Anaerobic metal corrosion in cultures of bacteria from estuarine sediments. In: *Biologically induced corrosion, NACE-8, Houston, Texas*, 137-143.

- Gaylarde, C.C. and H.A. Videla. 1987. Localised corrosion induced by a marine *vibrio*. *International Biodeterioration* 23, 91-104.
- Gaylarde, C.C. and H.A. Videla. 1989. Synergistic action of bacteria on the corrosion of mild steel in a marine medium. Proceedings of the 7th International Congress on Marine Corrosion and Fouling, 7-11 November, 1988, Valencia, Spain. In press.
- Geesey, G.G., M.W. Mittelman, T. Iwaoka and P.R. Griffiths. 1986. Role of bacterial exopolymers in the deterioration of metallic copper surfaces. *Material Performance* 25, 37-40.
- Geesey, G.G., L. Jang, J.G. Jolley, M.R. Hankins, T. Iwaoka and P.R. Griffiths. 1988. Binding of metal ions by extracellular polymers of biofilm bacteria. *Water Science Technology* vol.20, No 11/12, 161-165.
- Ghiorse, W.C. 1984. Biology of iron-depositing and manganese-depositing bacteria. *Annual Review of Microbiology* 38, 515-550.
- Gordon, A.S. 1987. Influence of alginate on attachment of *Vibrio* spp. to stainless steel surfaces in seawater. *Applied and Environmental Microbiology* 53, 1175-1177.
- Gros, D., B. Bruce, C.E. Challice and J. Schrevel. 1982. Ultrastructural localisation of Concanavalin A and wheat germ agglutinin binding sites in adult and embryonic mouse myocardium. *Journal of Histochemical Cytochemistry* 30, 193-200.
- Guezennec, J. and M. Therene. 1988. A study of the influence of cathodic protection on the growth of SRB and corrosion in marine sediments by electrochemical techniques. In *Microbial Corrosion-1*, (C.A.C. Sequeira and A.K. Tiller ed.), Elsevier Applied Science, London and New York, 256-265.
- Hamilton, W.A. 1985. Sulfate reducing bacteria and anaerobic corrosion. *Annual Review of Microbiology* 39, 195-217.
- Hardy, J.A. and J.L. Bown. 1984. The corrosion of mild steel by biogenic sulfide films exposed to air. *Corrosion* 40, 650-654.
- Harwood, J.H. and S.J. Pirt. 1972. Quantitative aspects of growth of the methane oxidising bacterium *Methylococcus capsulatus* on methane in shake flasks and continuous chemostat culture. *Journal of Applied Bacteriology* 35, 597-607.
- Hattori, R. 1972. Growth of *Escherichia coli* on the surface of an anion exchange resin in continuous flow system. *Journal of General Microbiology* 18, 319-330.
- Hendey, N.I. 1964. Some observations on *Cladosporium resinae* as a fuel contaminant and its possible role in the corrosion of aluminium alloy fuel tanks. *Transactions of British Mycological Society* 47, 467-475.
- Hollo, J., J. Toth, R.P. Tengerdy and J.E. Johnson. 1979. Denitrification and removal of heavy metals from waste water by immobilised microorganisms. In: *Immobilised microbial cells symposium series vol.106* (K. Ventkatasubramanian ed.), Washington D.C. 73-84.

- Hrabak, E.M., M.R. Urbano and F.B. Dazzo. 1982. Growth-phase-dependent immunodeterminants of *Rhizobium trifolii* lipopolysaccharide which bind trifoliin A, a white clover lectin. *Journal of Bacteriology* **148**, 697-711.
- Hsieh, K.M., L.W. Lion and M.L. Shuler. 1985. Bioreactors for the study of defined interactions of toxic metals and biofilms. *Applied and Environmental Microbiology* **50**, 1155-1161.
- Isaacson, R.E. 1985. Pilus adhesin in bacterial adhesion. In: *Bacterial adhesion* (D.C. Savage and M. Fletcher ed.), Plenum Press, N. York and London, 289-344.
- Iverson, W.P. and G.J. Olson. 1983. Anaerobic corrosion by sulfate reducing bacteria due to highly reactive volatile phosphorus compound. In: *Microbial corrosion*, The Metals Society, London, 46-53.
- Iverson, W.P. 1987. Microbial corrosion of metals. *Advanced and Applied Microbiology* **32**, 1-3.
- Jolley, J.G., G.G. Geesey, M.R. Hankins, R.B. Wright and P.L. Wichlacz. 1988. Auger electron spectroscopy and X-ray photoelectron spectroscopy of the biocorrosion of copper by gum arabic, BSC and *Pseudomonas atlantica* exopolymer. *Surface Interface Analysis* **11**, 371-376.
- Jolley J.G., G.G. Geesey, M.R. Hankins, R.B. Wright and P.L. Wichlacz. 1990. In situ real-time FT-IR/CIR/ATR study of the biocorrosion of copper by gum arabic, alginic acid, bacterial culture supernatant and *Pseudomonas atlantica* exopolymer. *Applied Spectroscopy*. In press.
- Jones, G.E. 1970. Metal organic complexes formed by marine bacteria. In: *Organic matter in natural waters*, (D.W. Hood ed.), Institute of Marine Science, Alaska, 301-306.
- Keevil, C.W., J.T. Walker, J. McEvoy and J.S. Colbourne. 1989. Detection of biofilms associated with pitting corrosion of copper pipework in Scottish hospitals. In: *Biocorrosion, Biodeterioration Society occasional publication No.5*, (C.C. Gaylarde and L.H.G. Morton eds.), 99-117.
- Kenne, L. and B. Lindberg. 1983. Bacterial polysaccharides. In: *The Polysaccharides vol.2*, (G.O. Aspinall ed.), Academic Press, New York and London, 287-363.
- Kennedy, A.F.D and I.W. Sutherland. 1987. Analysis of bacterial exopolysaccharides. *Biotechnology and Applied Biochemistry* **9**, 12-19.
- King, R.A., J.D.A. Miller and D.S. Wakerly. 1973. Corrosion of mild steel in cultures of sulfate reducing bacteria. *British Corrosion Journal* **8**, 89-93.
- King, R.A. 1982. Monitoring of microbiological activity and its relation to corrosion. In: *Corrosion monitoring in the oil, petrochemical and process industries* (J.N. Wanklyn ed.), Oyez Scientific and Technical Services Ltd., 99-111.
- King, R.A. and R.D. Eden. 1989. Evaluation of biofilms by advanced electrochemical monitoring. In: *Biocorrosion, Biodeterioration Society occasional publication No.5*, (C.C. Gaylarde and L.H.G. Morton eds.), 134-149.

- Kjelleberg, S., B.A. Humphrey and K.C. Marshall. 1982. Effect of interfaces on small, starved marine bacteria. *Applied and Environmental Microbiology* **43**, 1166-1172.
- Kumeda, H., Watanabe, K., Umemoto, T., Kato, K., Kondo, S. and Hisatsune, K. 1989. Chemical and biological properties of Lipopolysaccharides, Lipid A and Degraded Polysaccharide from *Wolinella recta* ATCC 33238. *Journal of General Microbiology* **135**, 1017-1025.
- Lion, L.W., M.L. Shuler, K-M. Hsieh and W.C. Ghiorse. 1988. Trace metal interaction with microbial biofilms in natural and engineered systems. *Critical Reviews in Environmental Control* **17**, 273-306.
- Little, B., P. Wagner, S.M. Gerchakov, M. Walch and R. Mitchell. 1986. The involvement of thermophilic bacterium in corrosion process. *Corrosion* **42**, 533-536.
- Lowry, O.M., N.J. Rosenbrough, A.L. Farr and R.J. Randall. 1951. Protein measurement with Folin phenol reagent. *Journal of Biology and Chemistry* **193**, 265-275.
- Luderitz, O., A.M. Staub and O. Westphal. 1966. Immunochemistry of O and R Ags of *Salomonella* and related *Enterobacteriaceae*. *Bacteriological Reviews* **30**, 193-225.
- McEldowney, S. and M. Fletcher. 1986. Variability of the influence of physicochemical factors affecting bacterial adhesion to polystyrene substrata. *Applied and Environmental Microbiology* **52**, 460-465.
- Mackie, E.B., K.N. Brown, J. Lam and J.W. Costerton. 1979. Morphological stabilisation of capsules of group B *Streptococci* types Ia, Ib, II and III with specific antibody. *Journal of Bacteriology* **138**, 609-617.
- Magnusson, K.E. 1982. Hydrophobic interaction - mechanism of bacterial binding. *Scandinavian Journal of Infectious Diseases, Suppl.* **3**, 32-36.
- Marshall, K.C., R. Stout and R.C.W. Berkeley. 1971. Mechanisms of the initial events in the sorption of marine bacteria to surfaces. *Journal of General Microbiology* **68**, 337-348.
- Mian, F.A., T.R. Jarman and R.C. Righelato. 1978. Biosynthesis of exopolysaccharide by *Pseudomonas aeruginosa*. *Journal of Bacteriology* **134**, 418-422.
- Miller, J.D.A. and A.K. Tiller. 1970. *Microbial aspects of metallurgy*, (J.D.A. Miller ed.), Elsevier, New York, 61-106.
- Mittelman, M.W. and G.G. Geesey. 1985. Copper binding characteristics of exopolymers from a freshwater sediment bacterium. *Applied and Environmental Microbiology* **49**, 846-851.
- Moreno, D.A., J.R. Ibars, I.B. Beech and C.C. Gaylarde. 1990. Biofilm formation on mild steel coupons by *Pseudomonas fluorescens* and *Desulfovibrio desulfuricans*. Biofouling. In Press.
- Nivens, D.E., P.D. Nichols, J.M. Henson, G.G. Geesey and D.C. White. 1986. Reversible acceleration of the corrosion of 304 stainless steel exposed to seawater induced by growth and secretion of the marine bacterium *Vibrio natriegens*. *Corrosion* **42**, 204-210.

- Obuekwe, C.O., D.W.S. Westlake, F.D. Cook and J.W. Costerton. 1981. Surface changes in mild steel coupons from the action of corrosion causing bacteria. *Applied and Environmental Microbiology* **41**, 766-774.
- Obuekwe, C.O., D.W.S. Westlake, J.A. Plambeck and F.D. Cook. 1981. Corrosion of mild steel in cultures of ferric iron reducing bacterium isolated from crude oil I. Polarisation characterisations. *Corrosion* **37**, 461-467.
- Ofek, I. 1977. Adherence of *E. coli* to human mucosal cells mediated by mannose receptors. *Nature (London)* **165**, 623-625.
- Ou, L.T. and M. Alexander. 1974. Influence of glass microbeads on growth, activity and morphological changes of *Bacillus megaterium*. *Archives of Microbiology* **101**, 35-44.
- Pankurst, E.S. 1968. Significance of sulphate reducing bacteria to the gas industry, a review. *Journal of Applied Bacteriology* **31**, 179-193.
- Parberry, D.G. 1968. The role of *Cladosporium resinae* in the corrosion of aluminium alloys. *International Biodeterioration Bulletin* **4**, 79-81.
- Parker, J.H., A. Smith, H.L. Fredrickson, J.R. Vestal and D.C. White. 1982. Sensitive assay, based on hydroxy-fatty acids from lipopolysaccharide lipid A for Gram negative bacteria in sediments. *Applied and Environmental Microbiology* **44**, 1170-1177.
- Paul, J.H. and W.H. Jeffrey. 1985. Evidence for separate adhesion mechanisms for hydrophobic and hydrophilic surfaces in *Vibrio proteolytica*. *Applied and Environmental Microbiology* **49**, 431-437.
- Pearce, W.A. and T.M. Buchman. 1980. Structure and cell membrane binding properties of bacterial fimbriae. In: *Bacterial adherence* (E.H. Beachey ed.), Chapman & Hall, London, 289-344.
- Pedersen, K. 1981. Electrostatic interaction chromatography, a method for assaying the relative surface charges of bacteria. *FEMS Microbiological Letters* **12**, 365-367.
- Petersen, P.K. and P.G. Quie. 1981. Bacterial surface components and the pathogenesis of infectious diseases. *Annual Review of Medicine* **32**, 29-43.
- Phillips, A.P., K.L. Martin and W. Horton. 1984. The choice of methods for IgG purification, yield and purity of antibody activity. *Journal of Immunological Methods* **74**, 385-393.
- Platt, R.M., G.G. Geesey, J.D. Davies and D.C. White. 1985. Isolation and partial chemical analysis of firmly bound exopolysaccharide from adherent cells of freshwater sediment bacterium. *Canadian Journal of Microbiology* **31**, 675-680.
- Pope, D.H. 1986. MIC in U.S. Industries. Detection and prevention. In: *Proceedings of the Argentine-U.S.A. workshop on biodeterioration* (Conicet-NSF), 105-118.
- Postgate, J.R. 1984. *The sulphate reducing bacteria*. Cambridge Univ. Press, Cambridge.

- Pringle, J.H. and M. Fletcher. 1983. Influence of substratum wettability on attachment of freshwater bacteria to solid surfaces. *Applied and Environmental Microbiology* **45**, 811-817.
- Pringle, J.H., M. Fletcher and D.C. Ellwood. 1983. Selection of attachment mutants during the continuous culture of *Pseudomonas fluorescens* and relationship between attachment ability and surface composition. *Journal of General Microbiology* **129**, 2557-2569.
- Quintero, E., K. Ishida, G. Gordon, and G.G. Geesey. 1989. Comparison of reduction methods for gas-chromatographic - mass spectrometric identification and quantitation of uronic acids in acidic polysaccharides. *Journal of Microbiological Methods* **9**, 309-322.
- Racusen, D. 1979. Glycoprotein detection in polyacrylamide gel with thymol and sulphuric acid. *Analytical Biochemistry* **99**, 474-476.
- Ray, T.C., A.R.W. Smith, K.J. Carter and R.C. Hignett. 1986. Composition of lipopolysaccharides from four strains of *Erwinia amylovora*. *Journal of General Microbiology* **132**, 3159-3167.
- Richmond, D.V. and D.J. Fisher. 1973. The electrophoretic mobility of microorganisms. *Advances in Microbial Physiology* **9**, 727.
- Robbins, P.W. and T. Uchida. 1962. Studies of the chemical basis of the phage conversion of O-antigens in E group *Salomonella*. *Biochemistry* **1**, 323-355.
- Robinson, J.A., M.G. Trulear and W.G. Characklis. 1984. Cellular reproduction and extracellular polymer formation by *Pseudomonas aeruginosa* in continuous culture. *Biotechnology and Bioengineering* **26**, 1409-1417.
- Rosenberg, M. 1981. Bacterial adherence to polystyrene. A replica method of screening for bacterial hydrophobicity. *Applied and Environmental Microbiology* **42**, 375-377.
- Rosenberg, M., E.A. Bayer, J. Delarea and E. Rosenberg. 1982. Role of thin fimbriae in adherence and growth of *Acinetobacter calcoaceticus* RAG-1 on hexadecane. *Applied and Environmental Microbiology* **44**, 929-937.
- Rutter, P.R. and B. Vincent. 1980. The adhesion of microorganisms to surfaces: physicochemical aspects. In: *Microbial adhesion to surfaces* (R.C.W. Berkeley, J.M. Lynch, J. Melling, P.R. Rutter, and B. Vincent ed.), Ellis Horwood Ltd., Chichester U.K., 79-92.
- Salvarezza, R.C., A.F.L. de Mele and H.A. Videla. 1979. The use of pitting potential to study the microbial corrosion of 2024 aluminium alloy. *International Biodeterioration Bulletin* **15**, 125-142.
- Salvarezza, R.C. and H.A. Videla. 1980. Passivity breakdown of mild steel in sea water in the presence of sulfate-reducing bacteria. *Corrosion* **36**, 550-554.
- Sequeira, C.A.C. 1988. Electrochemical techniques for studying microbial corrosion. In: *Microbial Corrosion-1*, (C.A.C. Sequeira and A.K. Tiller ed.), Elsevier Applied Science, London and New York, 99-118.



- Sherman, P.M. and R. Soni. 1988. Adherence of vero cytotoxin producing *Escherichia coli* of serotype O157-H7 to human epithelial cells in tissue culture: role of outer membranes as bacterial adhesins. *Journal of Medical Microbiology* **26**, 11-17.
- Sherwood, J.E., J.M. Vasse, F.B Dazzo and G.L. Truchet. 1984. Development and trifoliin A binding ability of the capsule of *Rhizobium trifolii*. *Journal of Bacteriology* **159**, 145-152.
- Siew, K. 1987. An analysis of the outer membrane of *Desulfovibrio vulgaris* (Woolich). PhD. thesis. City of London Polytechnic.
- Stanley, P.M. 1983. Factors affecting the irreversible attachment of *Pseudomonas aeruginosa* to stainless steel. *Canadian Journal of Microbiology* **29**, 1493-1499.
- Stojkovski, S., R.J. Magee and J. Liesegang. 1986. Molybdenum binding by *Pseudomonas aeruginosa*. *Australian Journal of Chemistry* **39**, 1205-1212.
- Sutherland, I.W. 1977. Bacterial polysaccharides: their nature and production. In: *Surface carbohydrates of the procaryotic cell* (I.W. Sutherland ed.), Academic Press N. York, 27-96.
- Sutherland, I.W. 1985. Biosynthesis and composition of Gram negative bacterial extracellular and wall polysaccharides. *Annual Review of Microbiology* **39**, 243-270.
- Tatnall, R.E. 1981. Fundamentals of bacteria induced corrosion. *Materials Performance* **23**, 14-18.
- Tiller, A.K. 1983. Electrochemical aspects of microbial corrosion: an overview. In: *Microbial Corrosion*, The Metals Society, London, 54-65.
- Togano, H., H. Sasaki, T. Nakahara, Y. Kanda and K. Osato. 1975. The influence of sulfate reducing bacteria on the corrosion of steel in artificial seawater. *Proceedings of the 6th International Congress on Metallic Corrosion*, Australian Corrosion Association, Victoria, 1258-1263.
- Uhlinger, D.J. and D.C. White. 1983. Relationship between physiological status and formation of extracellular polysaccharide glycocalyx in *Pseudomonas atlantica*. *Applied and Environmental Microbiology* **45**, 64-70.
- Walch, M. and Mitchell, R. 1983. Role of microorganisms in hydrogen embrittlement of metals. *Proceedings of National Association of Corrosion Engineers*, Corrosion 83, Paper No. 249, NACE, Houston.
- Wardell, J.N., C.M. Brown and D.C. Ellwood. 1980. A continuous culture study of the attachment of bacteria to surfaces. In: *Microbial adhesion to surfaces* ( R.C.W. Berkeley, J.M. Lynch, J. Melling, P.R. Rutter, and B. Vincent eds.), Ellis Horwood, Chichester, 221-230.
- Weimer, P.J., M.J. van Kavelaar, C.B. Michel and T.K. Ng. 1988. Effect of phosphate on the corrosion of carbon steel and on the composition of corrosion products in two-stage continuous cultures of *Desulfovibrio desulfuricans*. *Applied and Environmental Microbiology* **54**, 386-396.

- Westphal, O., and K. Jann. 1965. Bacterial lipopolysaccharides. Extraction with phenol-water and further applications of the procedure. *Methods in Carbohydrate Chemistry* 5, 83-91.
- Wheat, R.W. 1966. Analysis of hexosamines in bacterial polysaccharides by chromatographic procedures. *Methods in Enzymology* 8, 60-75.
- White, D.C., D.E. Nivens, P.D. Nichols, B.D. Kerger, J.M. Henson, G.G. Geesey and C.K. Clarke. 1985. Corrosion of steel induced by aerobic bacteria and their extracellular polymers. In: *Proceedings of International Workshop on Biodeterioration held at the University of La Plata, Argentina, March 1985, Aquatec Quimica, Sao Paulo*, 73-86.
- White, D.C., D.E. Nivens, P.D. Nichols, A.T. Mikell, B.D. Kerger, J.M. Henson, G.G. Geesey and K.C. Clarke. 1986. Role of aerobic bacteria and their extracellular polymers in the facilitation of corrosion. In: *Biologically induced corrosion, NACE-8, NACE, Houston, Texas*, 233-243.
- Wilkinson, S.G. 1977. Composition and structure of bacterial lipopolysaccharides. In: *Surface carbohydrates of the prokaryotic cell*, (I. Sutherland, ed.), Academic Press, New York, 97-175.
- Wray, W., V.P. Boulikas, T.A. Wray and T. Hancock. 1981. Silver staining of proteins in polyacrylamide gels. *Analytical Biochemistry* 118, 197-203.
- Van Loosdrecht, M.C.M., J. Lyklema, W. Norde, S. Goose and A.J.B. Zehnder. 1987. The role of bacterial cell wall hydrophobicity in adhesion. *Applied and Environmental Microbiology* 53, 1893-1897.
- van Loosdrecht, M.C.M., J. Lyklema, W. Norde, and A.J.B. Zennder. 1990. Influence of interfaces on microbial activity. *Microbiological Reviews* 54, 75-87.
- Videla, H.A., M.F.L. de Mele and G. Brankevitch. 1987. Microfouling of several metal surfaces in polluted sea water and its relation with corrosion. *Corrosion* 87, paper No. 380, NACE, Houston.
- Videla, H.A. 1988. Electrochemical interpretation of the role of microorganisms in corrosion. In: *Biodeterioration 7, Proceedings of the 7th International Biodeterioration Symposium, Cambridge*, (D.R. Houghton, R.N. Smith and H.O.W. Egging, eds.), Barking, Essex, Elsevier Applied Science, 359-371.
- Videla, H.A., S.G. Gomez de Saravia, M.F.L. de Mele and P.S. Guiamet. 1990. Bioelectrochemical assessment of biofilm effect on MIC of two different steels of industrial interest. *Corrosion* 90, paper No. 123, NACE, Houston.
- von Wolzogen Kuhr, G.A.H. and L.R. van der Vlugt. 1934. De grafiteering van gietijzer als electrobiochemisch proses in anaerobe gronden. *Water* 18, 147-165. Translation in: *Corrosion* (1961), 17, 293-299.
- Zaidi, B.R., R.F. Bard and T.R. Tosteson. 1984. Microbial specificity of metallic surfaces exposed to ambient seawater. *Applied and Environmental Microbiology* 48, 519-524.
- ZoBell, C.E. 1943. The effect of solid surfaces upon bacterial activity. *Journal of Bacteriology* 46, 39-56.

York, W.S., A.G. Darvill, M. McNeil, T.T. Stevenson and P. Albersheim. 1985. Isolation and characterisation of plant cell walls and cell wall components. *Methods in Enzymology* 118, 3-40.

## **APPENDIX**

**Composition of Postgate medium C: pH adjusted to 7.5**

<u>substance</u>	<u>g/l</u>
KH <sub>2</sub> PO <sub>4</sub>	0.5
NH <sub>4</sub> Cl	1
Na <sub>2</sub> SO <sub>4</sub>	4.5
CaCl <sub>2</sub> x 6H <sub>2</sub> O	0.06
MgSO <sub>4</sub> x 7H <sub>2</sub> O	0.06
Sodium lactate	6
Yeast extract	1
FeSO <sub>4</sub> x 7H <sub>2</sub> O	0.004
Sodium citrate x 2H <sub>2</sub> O	0.3

**Composition of Postgate medium B: pH adjusted to 7.5**

<u>substance</u>	<u>g/l</u>
KH <sub>2</sub> PO <sub>4</sub>	0.5
NH <sub>4</sub> Cl	1
CaSO <sub>4</sub>	1
MgSO <sub>4</sub> x 7H <sub>2</sub> O	2
Sodium lactate	3.5
Yeast extract	1
FeSO <sub>4</sub> x 7H <sub>2</sub> O	0.5
Thioglycollic acide	0.1
Ascorbic acid	0.1

**Composition of Postgate medium E: pH adjusted to 7.6**

<u>substance</u>	<u>g/l</u>
KH <sub>2</sub> PO <sub>4</sub>	0.5
NH <sub>4</sub> Cl	1
Na <sub>2</sub> SO <sub>4</sub>	1
CaCl <sub>2</sub> x 6H <sub>2</sub> O	1
MgCl <sub>2</sub> x 7H <sub>2</sub> O	2
Sodium lactate	3.5
Yeast extract	1
FeSO <sub>4</sub> x 7H <sub>2</sub> O	0.5
Thioglycollic acid	0.1
Ascorbic acid	0.1
Agar	15

**Composition of Mops buffer:**

0.15M NaCl  
50mM 3-N-morpholinopropane-sulfonic acid

**Composition of PBS buffer:**

<u>substance</u>	<u>g/l</u>
NaCl	8
KCl	0.2
KH <sub>2</sub> PO <sub>4</sub>	0.2

**Composition of cacodylate buffer:**

0.1M sodium cacodylate; pH adjusted with 0.1M NaOH

**Table 1A: COMPOSITION OF MILD AND STAINLESS STEEL STUBS**

**MILD STEEL BS970:1955 EN 1A**

C	Si	Mn	Ni	%	Cr	Mo	S	P
0.07	0.10	0.80	-	-	-	-	0.20	0.07
0.15	MAX	1.2	-	-	-	-	0.30	MAX

**STAINLESS STEEL TYPE 316 18Cr/8Ni EN 58J  
MOLYBDENUM BEARING CORROSION RESISTING**

Cr	NI	%	C	Mo
16.5	10	-	0.07	2.25
18.5	13	-	MAX	3.0

Figure 1A shows GC-FID chromatograph of 15 sugar standards. The computer printouts are an example of the calculations (integration of the areas under the sugar peaks) performed by the GC-FID data system, used for the estimation of carbohydrate levels in the analysed samples.

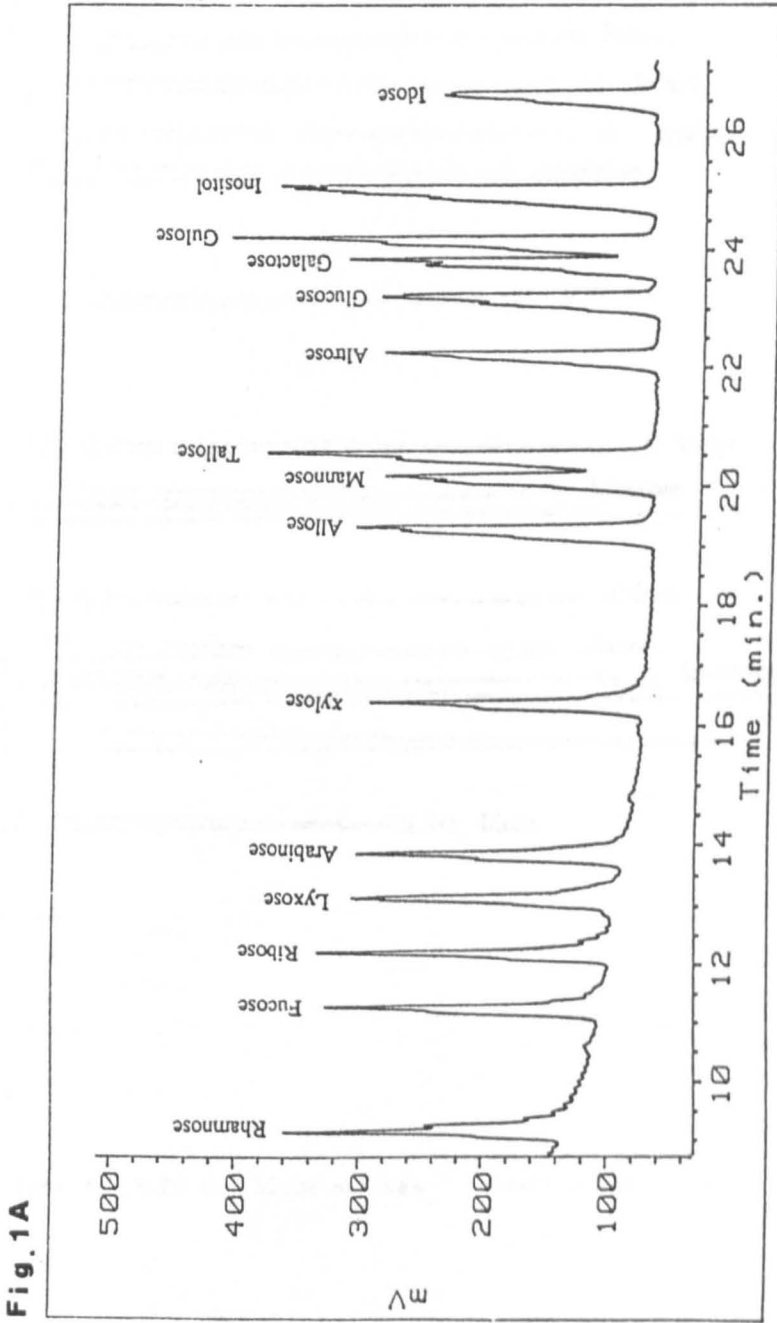

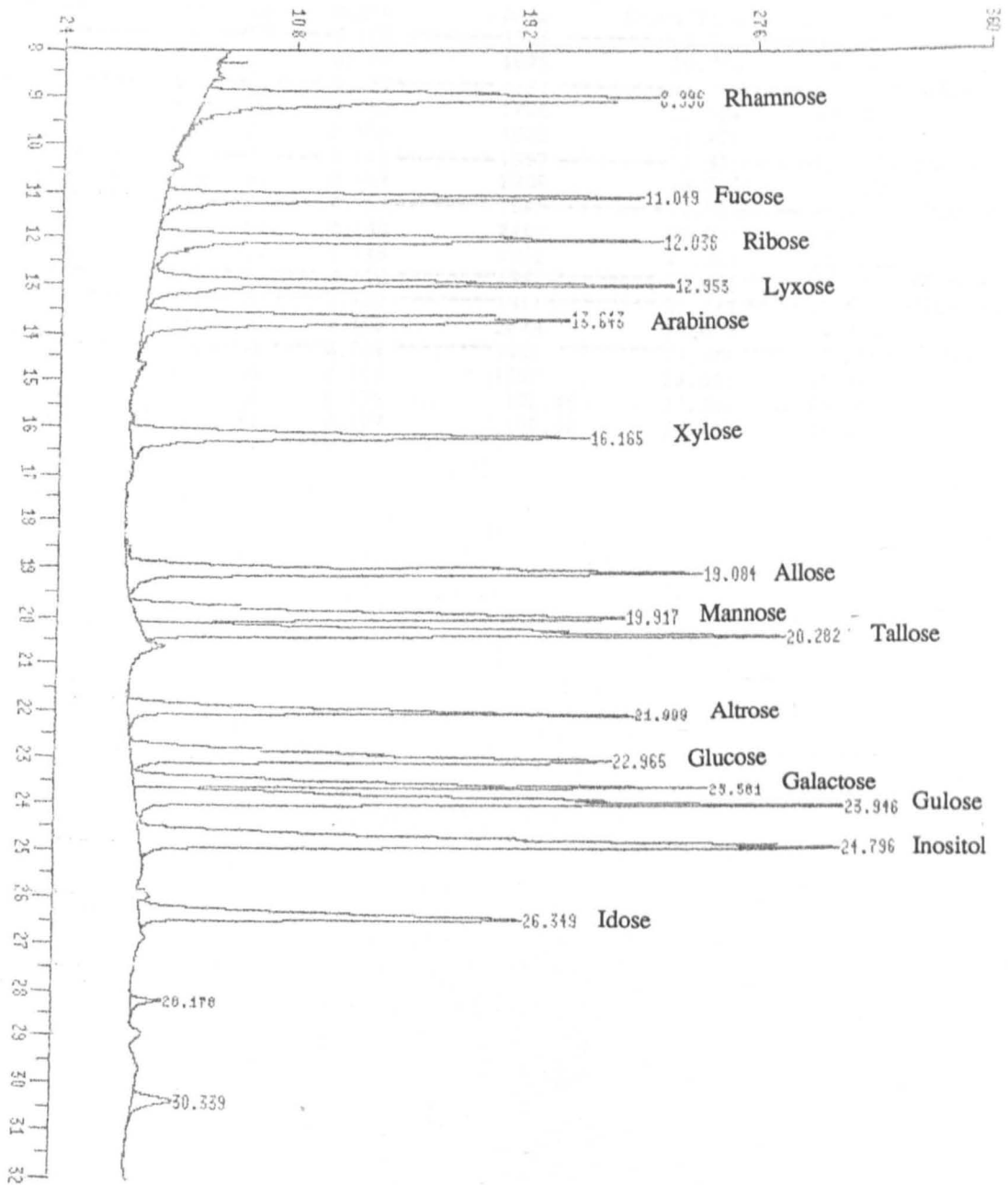

End of plot. Time = 8.00 to 32.00 minutes Chart speed = 0.83 cm/min



LC Y of SUGARS-3.D  
 DATA: SUGARS-3.D

Peak#	Ret Time	Type	Width	Area	Start Time	End Time	
1	8.996	PB	0.155	1768	8.781	10.301	Rhamnose
2	11.049	BV	0.144	1678	10.794	11.794	
3	12.036	PV	0.137	1661	11.794	12.594	Ribose
4	12.953	VV	0.162	1736	12.594	13.421	
5	13.643	VB	0.164	1626	13.421	14.541	
6	16.165	PB	0.142	1597	15.928	16.808	Xylose
7	19.084	BV	0.154	2295	18.288	19.557	
8	19.917	PV	0.154	1941	19.557	20.021	Mannose
9	20.282	VV	0.148	2462	20.021	20.448	
10	21.999	BV	0.145	1762	21.648	22.421	
11	22.965	PV	0.170	1997	22.421	23.248	Glucose
12	23.581	VV	0.137	1911	23.248	23.674	Galactose
13	23.946	VV	0.152	2649	23.674	24.314	
14	24.796	VB	0.208	3466	24.314	25.208	Inositol
15	26.349	VV	0.167	1552	26.021	26.701	
16	28.178	BB	0.178	132.49	27.954	28.648	
17	30.339	BB	0.197	185.00	30.101	30.928	

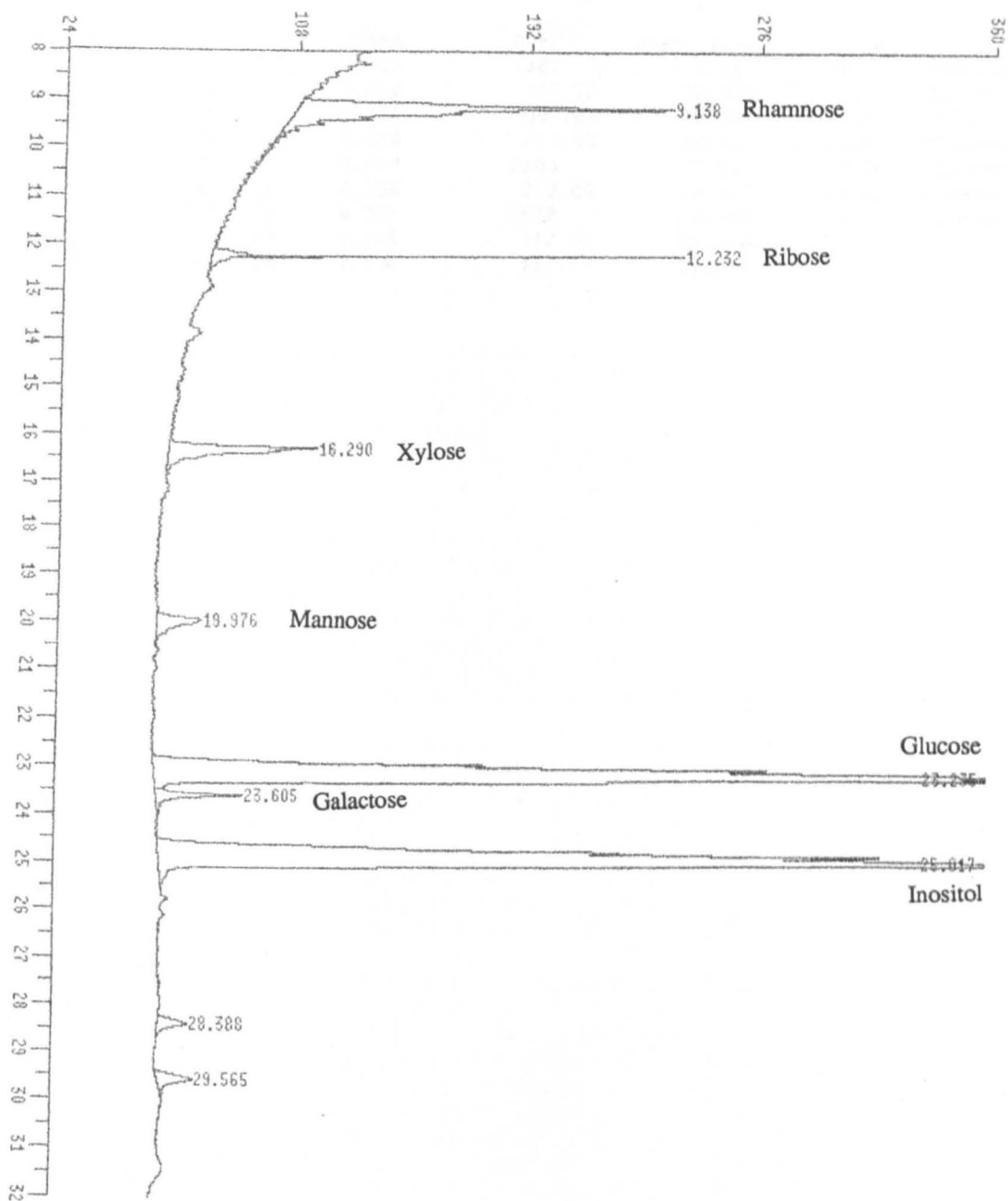

End of plot. Time = 8.00 to 32.00 minutes Chart speed = 0.83 cm/min

LC Y of PLPS-3.D  
DATA:PLPS-3.D

Peak#	Ret Time	Type	Width	Area	Start Time	End Time	
1	9.138	PB	0.168	1487	8.941	10.941	Rhamnose
2	12.232	BV	0.068	187.78	12.034	12.674	Ribose
3	16.290	BV	0.165	597.83	16.061	16.914	Xylose
4	19.976	BV	0.210	211.62	19.781	20.528	Mannose
5	23.235	BV	0.247	5503	22.661	23.461	Glucose
6	23.605	VB	0.155	210.05	23.461	24.061	Galactose
7	25.017	BB	0.226	5520	24.408	25.621	Inositol
8	28.388	BB	0.169	112.99	28.168	28.848	
9	29.565	BB	0.190	152.49	29.274	30.008	

## Adhesion of *Desulfovibrio desulfuricans* and *Pseudomonas fluorescens* to mild steel surfaces

IWONA B. BEECH & CHRISTINE C. GAYLARDE\* *Department of Biological Sciences, City of London Polytechnic, Old Castle Street, London E1 7NT, UK*

Received 5 October 1988 and accepted 26 January 1989

BEECH, I.B. & GAYLARDE, C.C. 1989. Adhesion of *Desulfovibrio desulfuricans* and *Pseudomonas fluorescens* to mild steel surfaces. *Journal of Applied Bacteriology* 67, 201-207.

The adhesion of micro-organisms to metal surfaces has been shown to be important in the corrosion process, but the cell surface structures participating in this adhesion have not previously been identified. Evidence is presented that a bacterial substance taking part in the initial adhesion of *Pseudomonas fluorescens* and *Desulfovibrio desulfuricans* (New Jersey) to mild steel is polysaccharide in nature. It is likely that this is present in the outer membrane of the bacterial cells as lipopolysaccharide.

It has been shown that preventing the adhesion of sulphate-reducing bacteria (SRB) to a metal surface retarded the rate of corrosion of that metal (Gaylarde & Johnston 1980). Later it was reported that increased corrosion is associated with mixed cultures of SRB and *Vibrio anguillarum* (Gaylarde & Johnston 1982) and it was suggested that a possible mechanism for this increase was the enhancement of SRB adhesion in mixed cultures. Further work with a different species of *Vibrio*, *V. alginolyticus*, showed adherent colonies of this organism accumulating on the metal surface and intense pitting was revealed when the cells were removed (Gaylarde & Videla 1987).

There can be little doubt that the adhesion of cells to metal surfaces plays a critical role in subsequent corrosion processes but there has been little work on the attachment of cells to metal. The available literature includes fundamental (Fletcher *et al.* 1980) and applied studies such as those concerned with the food-processing industry (Speers & Gilmour 1985) and with corrosion and fouling (Characklis 1981; Duddridge & Pritchard 1983; Dowling *et al.* 1987). It has been shown that not only do bacterial cells have the ability to accelerate cor-

rosion, but that non-enzymic extracellular products in the absence of living cells are also aggressive (Nivens *et al.* 1986). These extracellular materials are macromolecular polymers (extracellular polymeric substances, EPS), often of a polysaccharide nature (Nivens *et al.* 1986) and the postulated corrosion mechanism is the creation of sites of differing cathodic activity on the metal surface due to patchy accumulation of the products (White *et al.* 1985).

Extracellular polymeric substances have also been shown to bind metal ions selectively (Ford *et al.* 1988) and this could indicate alternative or additional mechanisms; chelation and removal of dissolved metal from the surface, or catalysis at active binding centres, both of which facilitate the corrosion process. Macromolecular polymers occur as structural components of all cells and the polysaccharide materials demonstrated to accelerate corrosion are also found in the lipopolysaccharides (LPS) present in the outermost layer of Gram-negative bacterial cells. In fact, it is difficult to differentiate between structural and excreted polysaccharide (Sutherland 1985). It has been reported that LPS in intact cells of the SRB genus *Desulfovibrio*, and in artificial membranes containing this macromolecule, interact specifically with  $Fe^{2+}$  ions (Bradley *et al.* 1984; Bradley & Gaylarde 1988).

\* Corresponding author.

Such interactions could be involved both in the corrosive action of SRB and in the attachment of cells of *Desulfovibrio* to ferrous metal surfaces in aqueous environments.

This communication reports a series of experiments which have been performed to elucidate the nature of the chemical structures involved in bacterial adhesion to metal. In addition to *Desulfovibrio*, a member of the genus *Pseudomonas* has been studied. *Pseudomonads* are commonly found in the aqueous environment and have been shown to produce EPS which may enhance corrosion (White *et al.* 1985).

## Materials and Methods

### ORGANISMS

*Desulfovibrio desulfuricans* subsp. *desulfuricans*, New Jersey (NCIMB 8313) was grown as batch cultures in Postgate's medium C (Postgate 1984) at 37°C. For adhesion experiments 5-day-old cultures were used. Stock cultures were kept in Postgate's medium B (Postgate 1984).

*Pseudomonas fluorescens* was isolated from a contaminated metal working fluid and identified by the API 20NE strip. The organism was grown on nutrient agar plates at 24°C and 48 h cultures used for adhesion experiments. Stock cultures were kept on nutrient agar slopes.

### METAL SURFACES

Cylindrical stubs (7 mm diameter, 3 mm depth) of mild steel (BS970) were sterilized dry by autoclaving in water-tight containers and kept in absolute alcohol before use. Before exposure to bacterial cultures the stubs were removed from the alcohol, immersed in 70% alcohol, flamed and placed inside sterile 25 ml screw-capped bottles.

### EXTRACTION OF LIPOPOLYSACCHARIDES FROM OUTER MEMBRANES OF BACTERIA

Lipopolysaccharides of *Desulfovibrio* and *Pseudomonas* were isolated from outer membranes of bacterial cells as described by Siew (1987) with slight modifications. The method of phenol-water extraction, applied originally to whole bacterial cells, was that of Westphal &

Jann (1965). Outer membranes were isolated from bacterial cells by a modified version of the de Pamphilis method (de Pamphilis 1971), in which lauroyl sarcosinate (Sarkosyl), known for its ability to solubilize bacterial cytoplasmic membranes (Filip *et al.* 1973), is used.

*Desulfovibrio* cells were harvested from batch cultures by centrifugation (5000 g for 30 min). *Pseudomonas* cells were collected from agar plates and, after resuspension in medium C, spun at 5000 g for 30 min. All subsequent procedures were identical for both organisms.

Pelleted cells were washed in cold MoPS buffer (50 mmol/l of 3-N-morpholino propane sulphonic acid, pH 7.4). The pellet was resuspended in 20 ml MoPS and sonicated in an MSE Soniprep 150 for ten 1 min bursts at 16  $\mu$ m amplitude. Unbroken cells and remaining debris were removed by centrifugation at 5000 g for 15 min. The supernatant fluid was incubated with 2% Sarkosyl at room temperature for 30 min. The mixture was centrifuged at 35 000 g for 30 min and the pellet, containing unsolubilized outer membrane, collected, resuspended in 50 ml of distilled water at 65–68°C and 50 ml of 90% aqueous phenol (w/v), preheated to 65–68°C, added. After cooling, the mixture was centrifuged at 3000 rev/min for 30–45 min to obtain three layer separation. The water phase containing bacterial LPS was collected and the remaining phenol layer and insoluble residue re-extracted with water. The combined water extracts were dialysed for 3–4 d at 4°C against distilled water to remove phenol and freeze-dried.

### PRODUCTION AND PURIFICATION OF ANTIBODIES AGAINST BACTERIAL LPS

New Zealand White rabbits, initially bled to obtain pre-immune sera, were immunized by subcutaneous injection. The antigen consisted of 5 mg of either *Desulfovibrio* or *Pseudomonas* LPS in distilled water plus 1 ml of Freund's complete adjuvant. After 1 week the procedure was repeated with Freund's incomplete adjuvant. Seven days after the last injection the animals were bled from the ear vein. Sera were separated from the clotted blood by centrifugation.

Immunoglobulins were partially purified from the antisera by salt precipitation with 32% w/v sodium sulphate (Phillips *et al.* 1984).

#### PREPARATION OF CELLS FOR ADHESION EXPERIMENTS

Cells of *D. desulfuricans* were harvested from broth cultures by centrifugation (500 g for 30 min). The pellet was resuspended in sterile medium C. Cells of *Ps. fluorescens* were washed from the surface of the nutrient agar plate with medium C.

Both suspensions were adjusted to the required concentrations after counting in an improved Neubauer haemocytometer. Steel stubs were added, after the aseptic addition of potential inhibitors of adhesion.

#### LECTIN TREATMENT

Lectins, concanavalin A (ConA) or wheat germ agglutinin (WGA) (Sigma), were dissolved in 1 ml of medium C and added to 9 ml of bacterial cell suspension through a 0.22  $\mu\text{m}$  filter, to give a final concentration of lectin of 125  $\mu\text{g}/\text{ml}$ . Bacteria were pre-incubated with lectin at room temperature for 30 min before exposure to mild steel stubs. Controls consisted of bacteria in medium C to which 1 ml of medium C had been added in place of lectin.

#### SUGAR PLUS LECTIN TREATMENT

Sugar inhibitors of WGA (N-acetyl glucosamine (glcNAc) and chitobiose) and of ConA (mannose, sucrose, glucose, glcNAc and chitobiose), all purchased from Sigma, were added to bacterial suspensions after filtration as described for lectins. Final sugar concentrations were those shown in the Results section. Sugars were added immediately after lectins and the cells pre-incubated with the mixture for 30 min before the addition of mild steel stubs.

#### ENZYME TREATMENT

The enzymes glucosidase, N-acetyl glucosaminidase and crude pronase (Sigma) were added after sterilization by filtration to bacterial cell suspensions to give the required concentrations (see Results section). The cells were pre-incubated with enzymes for 1-2 h before the introduction of mild steel stubs.

#### ANTIBODY TREATMENT

Bacterial cells were pre-incubated with 400  $\mu\text{g}/\text{ml}$  purified antibodies to LPS of *D. desulfuricans* or *Ps. fluorescens*, or with antibody against *Desulfovibrio vulgaris* (Woolwich) LPS, prepared in a similar fashion by L. K. Siew (City of London Polytechnic), for 1-4.5 h. Control suspensions contained equal concentrations of protein precipitated from pre-immune rabbit serum by the same method. All serum extracts were sterilized by filtration prior to use.

#### EPIFLUORESCENCE MICROSCOPY

After exposure to treated or untreated bacterial suspensions, stubs were removed and washed gently in distilled water to remove unattached cells. The washed surfaces were then stained for 5 min with 0.001% acridine orange. The dye was sterilized and cleared of particulate matter by filtration through a 0.22  $\mu\text{m}$  pore size filter before use. After subsequent washing of the stubs with sterile distilled water, they were placed onto glass slides, covered with cover slips and examined at a magnification of  $\times 400$  with a standard Zeiss light microscope fitted with epifluorescent illumination with a halogen lamp. The numbers of cells adhering to the surfaces were estimated by counting fluorescing cells within an area of a microscope field delineated by an etched eyepiece (0.03  $\text{mm}^2$ ). Ten to twenty such areas, representing up to 2% of the total surface area (3.14  $\text{mm}^2$ ), were randomly selected and counted on each stub. Each experiment was repeated at least three times and the results were evaluated by two-tailed unpaired *t*-tests.

#### Results

Tables 1, 2 and 3 show the effects of lectins and lectins plus sugars on the adhesion to mild steel of *Ps. fluorescens* and *D. desulfuricans*. Both

**Table 1.** Effect of lectins on the adhesion of *Pseudomonas fluorescens* to mild steel. Initial cell concentration  $10^5$  cells/ml

Treatment	Mean no. cells/ 0.03 $\text{mm}^2 \pm$ S.D.	Statistical significance
Control	50.33 $\pm$ 5.37	—
ConA	34.8 $\pm$ 8.89	$P < 0.05$
WGA	36.2 $\pm$ 13.3	$P < 0.05$

ConA, concanavalin A; WGA, wheat germ agglutinin.

**Table 2.** Effect of lectins and lectins plus sugars on the adhesion of *Pseudomonas fluorescens* to mild steel

Concentration (cells/ml)	Treatment*	Mean no. cells/ 0.03 mm <sup>2</sup> ± s.d.	Statistical significance
10 <sup>5</sup>	Control	50.1 ± 11.44	—
	ConA	30.6 ± 5.68	P < 0.05
	ConA + man	30.52 ± 9.66	P < 0.05
	ConA + suc	30.5 ± 6.13	P < 0.05
	ConA + glc	47.86 ± 15.75	P > 0.05
	ConA + glcNAc	47.06 ± 8.87	P > 0.05
5 × 10 <sup>5</sup>	Control	60.6 ± 10.59	—
	WGA	36.59 ± 8.91	P < 0.05
	WGA + glcNAc	57.42 ± 11.27	P > 0.05

\* Sugar concentrations: mannose (man), 313 µg/ml; sucrose (suc), 2500 µg/ml; glucose (glc), 2500 µg/ml; N-acetyl glucosamine (glcNAc), 625 µg/ml.

ConA, concanavalin A; WGA, wheat germ agglutinin.

**Table 3.** Effect of lectins and lectins plus sugars on the adhesion of *Desulfovibrio desulfuricans* to mild steel

Concentration (cells/ml)	Treatment*	Mean no. cells/ 0.03 mm <sup>2</sup> ± s.d.	Statistical significance
10 <sup>5</sup>	Control	40.13 ± 5.85	—
	ConA	28.0 ± 5.55	P < 0.05
	ConA + glc	28.0 ± 5.44	P < 0.05
	ConA + chit	36.9 ± 5.66	P > 0.05
	WGA	27.44 ± 5.02	P < 0.05
	WGA + chit	39.4 ± 5.59	P > 0.05
8 × 10 <sup>6</sup>	Control	82.4 ± 9.87	—
	ConA	62.4 ± 4.72	P < 0.05
	ConA + man	58.8 ± 4.81	P < 0.05
	ConA + glcNAc	52.8 ± 7.87	P < 0.05

\* Sugar concentrations: mannose (man), 939 µg/ml; glucose (glc), 2500 µg/ml; N-acetyl glucosamine (glcNAc), 625 µg/ml; chitobiose (chit), 212 µg/ml.

ConA, concanavalin A; WGA, wheat germ agglutinin.

**Table 4.** Influence of glucosidase and N-acetyl glucosaminidase on adhesion of *Pseudomonas fluorescens* and *Desulfovibrio desulfuricans* to mild steel

Species (cells/ml)	Treatment	Mean no. cells/ 0.03 mm <sup>2</sup> ± s.d.	Statistical significance
<i>Pseudomonas fluorescens</i> (10 <sup>5</sup> )	Control	52.23 ± 9.0	—
	Glucosidase 2 u/ml	43.0 ± 11.69	P < 0.05
	10 u/ml	41.86 ± 10.23	P < 0.05
	18 u/ml	35.55 ± 11.48	P < 0.05
	glcNAc-ase 0.1 u/ml	43.8 ± 12.9	P < 0.05
	0.5 u/ml	32.8 ± 10.12	P < 0.05
	0.9 u/ml	25.85 ± 6.43	P < 0.05
<i>Desulfovibrio desulfuricans</i> (8 × 10 <sup>5</sup> )	Control	53.9 ± 7.63	—
	Glucosidase 18 u/ml	49.2 ± 6.92	P > 0.05
	glcNAc-ase 0.5 u/ml	37.86 ± 9.60	P < 0.05

glcNAc, N-acetyl glucosamine.

**Table 5.** Effect of pronase and pronase plus lectin treatment on adhesion of *Pseudomonas fluorescens* and *Desulfovibrio desulfuricans* to mild steel. Initial cell concentrations  $10^9$ /ml.

Species	Treatment*	Mean no. cells/ 0.03 mm <sup>2</sup> ± s.d.	Statistical significance
<i>Pseudomonas fluorescens</i>	Control	50.33 ± 5.37	—
	Pronase	50.6 ± 4.82	$P > 0.05$
	Pronase + WGA	38.6 ± 5.62	$P < 0.05$
	WGA	36.2 ± 13.3	$P < 0.05$
	Pronase + ConA	37.26 ± 7.13	$P < 0.05$
<i>Desulfovibrio desulfuricans</i>	Control	42.22 ± 5.68	—
	Pronase	41.2 ± 5.31	$P > 0.05$
	Pronase + WGA	29.6 ± 3.77	$P < 0.05$
	WGA	27.44 ± 5.02	$P < 0.05$
	ConA	34.8 ± 8.89	$P < 0.05$

\* Pronase concentration 200 µg/ml.

WGA, wheat germ agglutinin; ConA, concanavalin A.

lectins reduced adhesion significantly and this reduction was reversed by glucose and glcNAc in the case of *Ps. fluorescens* and by chitobiose in the case of *D. desulfuricans*.

The effects of treating the cells with enzymes are shown in Table 4. Glucosidase and *N*-acetyl glucosaminidase reduced the adhesion of *Ps. fluorescens*, whilst the numbers of adherent cells of *D. desulfuricans* were reduced only by *N*-acetyl glucosaminidase.

The adhesion of bacterial species was unaffected by pronase treatment and the adhesion of pronase-treated cells remained sensitive to lectins (Table 5).

Antibodies raised against extracted LPS from the two species were able to inhibit the adsorption to mild steel of homologous cells only (Table 6).

### Discussion

Both WGA and ConA significantly reduced the number of cells of *Ps. fluorescens* adhering to mild steel (Table 1). This reduction can be reversed, in the case of ConA, by glucose and glcNAc, but not by mannose or sucrose (Table 2). As expected, WGA inhibition of adhesion is reversed by glcNAc. These results differ from those obtained with *D. desulfuricans* (Table 3). Although WGA and ConA inhibit adhesion, this effect cannot be reversed by any of the previously named sugars. However, reversal does occur when the disaccharide form of glcNAc, chitobiose, is used (Table 3). Chitobiose has previously been shown to be a more effective antagonist of WGA than glcNAc (Adair & Kornfeld 1974).

**Table 6.** Numbers of bacterial cells adhering to mild steel within 1 h after pre-incubation of cells with specific antibodies for 1.5 h

Species	Pre-incubation with	Mean number of cells adhering to 0.03 mm <sup>2</sup> ± s.d.
<i>Desulfovibrio desulfuricans</i>	Medium C only	48.05 ± 7.83
	NRS	50.7 ± 12.4
	A-LPS <sub>PF</sub>	49.9 ± 5.98
	A-LPS <sub>DD</sub>	33.4 ± 8.9
	A-LPS <sub>DV</sub>	31.4 ± 8.21
<i>Pseudomonas fluorescens</i>	Medium C only	50.02 ± 8.76
	NRS	50.12 ± 6.88
	A-LPS <sub>PF</sub>	29.0 ± 4.37
	A-LPS <sub>DD</sub>	49.7 ± 8.2
	A-LPS <sub>DV</sub>	50.7 ± 7.02

NRS, Normal rabbit serum; A-LPS<sub>PF</sub>, antibody to *Ps. fluorescens* lipopolysaccharide (LPS); A-LPS<sub>DD</sub>, antibody to *D. desulfuricans* LPS; A-LPS<sub>DV</sub>, antibody to *D. vulgaris* LPS.



The inference to be drawn from these results is that *Ps. fluorescens* adhesion is associated with the presence of glucose and N-acetyl glucosamine on the cell surface and that *D. desulfuricans* adhesion is associated with a di- or polymeric form of glcNAc. Confirmatory evidence for these conclusions comes from the results of enzyme treatment. Glucosidase, which removes glucose residues from the cell surface, reduces the attachment of *Ps. fluorescens* to mild steel, as does N-acetyl glucosaminidase (Table 4). Only N-acetyl glucosaminidase is effective for *D. desulfuricans*.

Although these results indicate that glucose and/or glcNAc are part of bacterial cell surface structures associated with adhesion, they give no information about the type of macromolecule involved. Sugars could be present as either polysaccharide or glycoprotein in the cell walls. To differentiate between these two possibilities, the results of the other treatments must be assessed. Treatment of *D. vulgaris* (Woolwich) with protease removes a major portion of the outer membrane proteins, whilst leaving LPS relatively unaffected (Bradley 1985). Table 5 shows that the incubation of cells of *D. desulfuricans* and *Ps. fluorescens* with protease does not influence their ability to adhere to mild steel and that cells thus treated are still susceptible to lectin inhibition of adhesion. This implies that the sugar-containing macromolecule involved in adhesion is probably not a glycoprotein, but a polysaccharide.

The existence of this polysaccharide as LPS is indicated by the results of adhesion studies on cells treated with antibodies raised against extracted bacterial LPS (Table 6). The adhesion of both *Pseudomonas* and *Desulfovibrio* cells is inhibited by treatment with homologous, but not with heterologous, antibodies.

Lipopolysaccharide has been shown to be involved in bacterial adhesion to biological surfaces (Peterson & Quie 1981), but attachment to inert (non-biological) surfaces has generally been regarded as non-specific, involving only physical factors such as hydrophobic interactions and hydrogen bonding (Fletcher 1980; Savage & Fletcher 1985). The identification of the involvement of a specific surface macromolecule in bacterial adsorption to mild steel offers new approaches for the discovery of potential inhibitors of microbial fouling. These experiments demonstrate an important inter-

action in the very first stages of biofilm formation on metal surfaces.

## References

- ADAIR, W. L. & KORNFIELD, S. 1974 Isolation of the receptors for wheat germ agglutinin and the *Ricinus communis* lectins from human erythrocytes using affinity chromatography. *Journal of Biological Chemistry* **249**, 4696-4704.
- BRADLEY, G. 1985 An investigation of the structure and functional aspects of the cell wall of *Desulfovibrio*. Ph.D. thesis, CNAAC, City of London Polytechnic.
- BRADLEY, G. & GAYLARDE, C.C. 1988 Iron uptake by *Desulfovibrio vulgaris* outer membrane components in artificial vesicles. *Current Microbiology* **17**, 189-192.
- BRADLEY, G., GAYLARDE, C.C. & JOHNSTON, J.M. 1984 A specific interaction between ferrous ions and lipopolysaccharides in *Desulfovibrio vulgaris*. *Journal of General Microbiology* **130**, 441-444.
- CHARACKLIS, W.G. 1981 Fouling biofilm development: A process analysis. *Biotechnology and Bioengineering* **23**, 1923-1960.
- DE PAMPHILIS, M.C. 1971 Dissociation and reassembly of *Escherichia coli* outer membranes and lipopolysaccharides: their assembly onto flagellar basal bodies. *Journal of Bacteriology* **105**, 1184-1199.
- DOWLING, N.J.E., GUEZENNEC, J. & WHITE, D.C. 1987 Facilitation of corrosion of stainless steel exposed to aerobic seawater by microbial biofilms containing both facultative and absolute anaerobes. In *Microbial Problems in the Offshore Oil Industry* ed. Hill, E.C., Shennan, J.L. & Watkinson, R.J. pp. 27-38. Chichester: Wiley & Sons.
- DUDDRIDGE, J.E. & PRITCHARD, A.M. 1983 Factors affecting adhesion of bacteria to surfaces. In *Microbial Corrosion* pp. 28-35. London: The Metals Society.
- FILIP, C., FLETCHER, G., WULFF, J.L. & EARHART, C.F. 1973 Solubilisation of the cytoplasmic membrane of *Escherichia coli* by the ionic detergent sodium lauroyl sarcosinate. *Journal of Bacteriology* **115**, 717-722.
- FLETCHER, M. 1980 The question of passive versus active attachment mechanisms in non-specific bacterial adhesion. In *Microbial Adhesion to Surfaces* ed. Berkeley, R.C.W., Lynch, J.M., Melling, J., Rutter, P.R. & Vincent, B. pp. 197-210. Chichester: Ellis Horwood.
- FLETCHER, M., LATHAM, M.J., LYNCH, J.M. & RUTTER, P.R. 1980 The characteristics of interfaces and their role in microbial attachment. In *Microbial Adhesion to Surfaces* ed. Berkeley, R.C.W., Lynch, J.M., Melling, J., Rutter, P.R. & Vincent, B. pp. 67-78. Chichester: Ellis Horwood.
- FORD, T.E., MAKI, J.S. & MITCHELL, R. 1988 Involvement of bacterial exopolymers in biodeterioration of metals. In *Biodeterioration 7* ed. Houghton, D.R., Smith, R.N. & Eggins, H.O.W. pp. 378-384. Barking: Elsevier Applied Science.
- GAYLARDE, C.C. & JOHNSTON, J.M. 1980 The importance of microbial adhesion in anaerobic metal cor-

- rosion. In *Microbial Adhesion to Surfaces* ed. Berkeley, R.C.W., Lynch, J.M., Melling, J., Rutter, P.R. & Vincent, B. pp. 511-513. Chichester: Ellis Horwood.
- GAYLARDE, C.C. & JOHNSTON, J.M. 1982 The effect of *Vibrio anguillarum* on anaerobic metal corrosion induced by *Desulfovibrio vulgaris*. *International Biodeterioration Bulletin* **18**, 111-116.
- GAYLARDE, C.C. & VIDELA, H.A. 1987 Localised corrosion induced by a marine vibrio. *International Biodeterioration* **23**, 91-104.
- NIVENS, D.E., NICHOLS, P.D., HENSON, J.M., GEESEY, G.G. & WHITE, D.C. 1986 Reversible acceleration of corrosion of stainless steel exposed to seawater induced by the extracellular secretions of the marine vibrio *Vibrio natriegens*. *Corrosion* **42**, 204-210.
- PETERSON, P.K. & QUIE, P.G. 1981 Bacterial surface components and the pathogenesis of infectious diseases. *Annual Review of Medicine* **32**, 29-43.
- PHILLIPS, A.P., MARTIN, K.L. & HORTON, W. 1984 The choice of methods for IgG purification, yield and purity of antibody activity. *Journal of Immunological Methods* **74**, 385-393.
- POSTGATE, J.R. 1984 *The Sulphate-reducing Bacteria* p. 32. Cambridge: Cambridge University Press.
- SAVAGE, D.C. & FLETCHER, M. 1985 *Bacterial Adhesion*. New York: Plenum Publishers.
- SIEW, L.K. 1987 An analysis of the outer membrane of *Desulfovibrio vulgaris* (Woolwich). Ph.D. thesis, CNAAC, City of London Polytechnic.
- SPEERS, J.G.S. & GILMOUR, A. 1985 The influence of milk and milk components on the attachment of bacteria to farm dairy equipment surfaces. *Journal of Applied Bacteriology* **59**, 325-332.
- SUTHERLAND, I. 1985 Biosynthesis and composition of Gram negative bacterial extracellular and wall polysaccharides. *Annual Review of Microbiology* **39**, 243-270.
- WESTPHAL, O. & JANN, K. 1965 Bacterial lipopolysaccharides. Extraction with phenol/water and further applications of the procedure. *Methods in Carbohydrate Chemistry* **5**, 83-91.
- WHITE, D.C., NIVENS, D.E., NICHOLS, P.D., KERGER, B.D., HENSON, J.M., GEESEY, G.G. & CLARKE, C.K. 1985 Corrosion of steels induced by aerobic bacteria and their exocellular polymers. In *Proceedings of the International Workshop on Biodeterioration*, University of La Plata, Argentina, March 1985. Sao Paulo, Aquatec.

# MICROBIAL CORROSION—1

*Edited by*

**C. A. C. SEQUEIRA**

*Instituto Superior Técnico, Technical University of Lisbon, 1096 Lisbon Codex,  
Portugal*

and

**A. K. TILLER**

*National Corrosion Service, National Physical Laboratory, Teddington,  
Middlesex TW11 0LW, UK*



**ELSEVIER APPLIED SCIENCE**  
LONDON and NEW YORK

## CONTENTS

<i>Preface</i> . . . . .	v
 <b>INTRODUCTORY SURVEY</b>	
The impact of microbially induced corrosion on engineering alloys . . . . . A. K. TILLER	3
 <b>MECHANISMS</b>	
Mechanism of anaerobic microbial corrosion in the marine environment . . . . . W. A. HAMILTON, A. N. MOOSAVI and R. N. PIRRIE	13
Molecular basis of bacterial adhesion to metals . . . . . C. C. GAYLARDE and I. B. BEECH	20
The enhancement of reaction kinetics by bacteria . . . . . A. POURBAIX and M. MARQUEZ JACOME	29
Algal-bacterial interactions and their effects on corrosion and corrosion-fatigue . . . . . R. EDYVEAN	40
The effect of marine fouling on hydrogen uptake by steel . . . . . U. W. OBUZOR, K. R. GOWERS and R. A. COTTIS	53
Utilization of cathodic hydrogen by <i>Desulfovibrio</i> species with sulfate or nitrate as terminal electron acceptor . . . . . B. S. RAJAGOPAL, M. F. LIBERT and J. LE GALL	66
Microbial corrosion under various nitrogen or hydrogen pressures . . . . . PH. CHAVATTE, C. ROMOND, J. P. CARNUS and C. HASLAY	79
Sulphate- and sulphite-reducing bacteria symbiosis in microbial corrosion . . . . . D. A. MORENO and F. LABORDA	84
Corrosion products from SRB environments . . . . . G. EIDSÅ	91
Fouling biofilms and corrosion (Abstract only). . . . . W. G. CHARACKLIS	95
 <b>TESTING</b>	
Electrochemical techniques for studying microbial corrosion . . . . . C. A. C. SEQUEIRA	99
Rapid detection of corrosion-causing organisms . . . . . C. GAYLARDE	119

## MOLECULAR BASIS OF BACTERIAL ADHESION TO METALS

C.C. Gaylarde and I.B. Beech  
Department of Biological Sciences, City of London Polytechnic,  
Old Castle Street, London E1 7NT, UK.

## ABSTRACT

The adhesion of microorganisms to metal surfaces has been shown to be important in the corrosion process, but the cell surface structures participating in this adhesion have not previously been identified. Evidence is presented that the material necessary for adhesion of *Pseudomonas fluorescens* and *Desulfovibrio desulfuricans* (New Jersey) to mild steel is polysaccharide in nature. It is likely that this is present in the outer membrane of the bacterial cells as lipopolysaccharide.

During the last ten years increased interest in the study of associations between microorganisms and inert surfaces has become apparent. Much of this increase can be attributed to the recognition of the importance of attached (sessile) organisms in terms of numbers and activity. One square centimetre of a surface submerged in a stream can possess a population of bacteria the same size as that found in a litre of the flowing water (1) and attached bacterial cells have been shown to have greatly increased glucose-utilising activity compared with those in the planktonic phase (2).

In 1980, it was shown that preventing the adhesion of sulphate-reducing bacterial (SRB) cells to metal surfaces retarded the rate of corrosion of that metal (3). A later publication reported the increased corrosion associated with mixed cultures of SRB and *Vibrio anguillarum* (4) and it was suggested that a possible mechanism for this increase was the enhancement of SRB adhesion in mixed cultures. Further work with a different species of vibrio, *V. alginolyticus*, showed adherent colonies of this organism accumulating on the metal surface, with associated areas of intense pitting revealed on removal of the cells (5).

There can be little doubt that the adhesion of cells to metal surfaces plays a critical role in any subsequent corrosion processes, and yet there has been little work on the attachment of cells to metal. The adhesion of bacterial cells to living surfaces has been extensively studied (6,7,8,9). Many animal and plant pathogens have been shown to utilise specific receptors for adhesion (10,11,12). The attachment of bacterial cells to non-living ("inert") surfaces has gained less attention. Nevertheless there are a number of studies of bacterial adhesion to glass and plastic (13,14,15,16,17,18) and to rubber (19,20).

The literature on microbial attachment to metal surfaces tends to concentrate in three areas. Fundamental studies of adhesion have used metal as a test surface for comparison with other, more hydrophobic or more negatively charged surfaces (21). The two more applied areas in which a body of information on adhesion is to be found are the food processing industry (19) and corrosion and fouling (22,23,24). It has been shown that not only do bacterial cells have the ability to accelerate corrosion, but that extracellular products in the absence of living cells are also aggressive (25). These extracellular materials are macromolecular polymers ("extracellular polymeric substances", EPS), often of a polysaccharide nature (25) and the postulated corrosion mechanism is the creation of sites of differing cathodic activity on the metal surface due to patchy accumulation of the products (26).

EPS have also been shown to bind metal ions (27) and this could indicate alternative or additional mechanisms; chelation and removal of dissolved metal from the surface or catalysis at active binding centres, both of which facilitate the corrosion process. Macromolecular polymers occur as structural components of all cells and the polysaccharide materials demonstrated to accelerate corrosion are also found in the lipopolysaccharide (LPS) present in the outermost layer of Gram negative bacterial cells. In fact, it is difficult to differentiate between structural and excreted polysaccharide (28). It has been reported that LPS in intact cells of the SRB, *Desulfovibrio*, interacts specifically with  $Fe^{2+}$  ions (29). Further work has shown that this interaction also occurs when the LPS is incorporated into artificial phospholipid vesicles, mimicking the outer cell layer (30). Analytical experiments using isolated LPS from

*D. vulgaris* have indicated that the interaction probably occurs between the saccharide moiety of the macromolecule and Fe<sup>2+</sup> ions (31). Such interactions could be involved both in the corrosive action of SRB and in the attachment of cells of *Desulfovibrio* to ferrous metal surfaces in aqueous environments.

This communication reports a series of experiments which have been performed to elucidate the nature of the chemical structures involved in bacterial adhesion to metal. In addition to *Desulfovibrio*, a member of the genus *Pseudomonas* has been studied, since pseudomonads are commonly found in the aqueous environment and have been shown to produce EPS which may accelerate corrosion (26). In this study, *Desulfovibrio desulfuricans* New Jersey (NCIMB 8313) and a member of the *Pseudomonas fluorescens* group isolated from a contaminated metal working fluid are employed. Adhesion of the cells to mild steel (BS970) and stainless steel (BS316) stubs, 0.7 cm<sup>2</sup> in diameter, is observed by scanning electron microscopy and the adherent cells are enumerated by fluorescence microscopy of acridine orange-stained specimens. The ability of various materials to inhibit adhesion is evaluated by the unpaired, 2-tailed T-test on data collected by microscopical analyses. Although the distribution of cells on the metal surface may be non-random (Cook and Gaylarde, unpublished results), it has been shown that parametric tests may reliably be used to assess adherence data (32).

A number of techniques may be used to determine the importance of sugars in the adhesion process. One widely used tool in such studies is the group of substances called lectins. These are naturally occurring proteins or glycoproteins which bind to cell surfaces, often causing cell agglutination. The binding of lectins can be specifically inhibited by various sugar molecules. For example, concanavalin A (ConA) is antagonised by the sugars glucose, mannose, sucrose and N-acetylglucosamine (NAG), whilst wheat germ agglutinin (WGA) binding is inhibited only by NAG. There is a high degree of specificity in the binding activity of lectins which makes them ideal tools in molecular biology.

In the studies reported here, ConA and WGA have been used to determine the importance of the sugars glucose, mannose, sucrose and NAG in the attachment of *D. desulfuricans* and *Ps. fluorescens* to mild steel surfaces. Mild

steel is the chosen material because cells adhere to this surface in greater numbers than to stainless steel (Table 1). Experiments are routinely performed in Postgate's Medium C (33), thus providing the cells with an

TABLE 1

Cells adhering to 0.03 mm<sup>2</sup> of metal surface after 1 h incubation in Medium C containing 10<sup>5</sup> cells/ml

Organism	Metal	Adherent cells (mean ± S.D.)
Pseudomonas	Mild steel	50.25 ± 7.04
	Stainless steel	23.15 ± 3.97
Desulfovibrio	Mild steel	37.6 ± 5.02
	Stainless steel	18.8 ± 1.30

environment of low Eh and an energy source, although during the time course of these experiments (1 - 1.5 h) no increase in cell numbers occurs. Since cells are often stated to show greater adherence in low nutrient environments (34,35), the results of a comparison between adhesion of *D. desulfuricans* in Postgate's Medium C and in distilled water as the suspending medium are shown in Table 2. It can be seen that over 1.5 h there is no difference in bacterial numbers adhering in either environment.

TABLE 2

Cells of *D. desulfuricans* adhering to mild and stainless steel surfaces (0.03 mm<sup>2</sup>) after 1.5 h incubation in Medium C and in distilled water, each containing 10<sup>5</sup> cells/ml

Medium	Metal	Adherent cells (± S.D.)
Medium C	Mild steel	37.6 ± 5.02
Water	Mild steel	36.1 ± 4.72
Medium C	Stainless steel	11.8 ± 1.3
Water	Stainless steel	10.13 ± 2.19

Table 3 shows the results of lectin treatment on the adhesion of *Ps. fluorescens*. Both WGA and ConA significantly reduce the number of cells adhering to mild steel. This reduction can be reversed, in the case of ConA, by glucose and NAG, but not by mannose or sucrose (Table 4). As expected, WGA inhibition of adhesion is reversed by NAG.



TABLE 3

Cells of *Ps. fluorescens* adhering to 0.03 mm<sup>2</sup> mild steel surface in Medium C with or without lectins (125 ug/ml)

Additions to medium	Original cell concentration/ml	Adherent cells (± S.D.)
None (control 1)	10 <sup>5</sup>	50.1 ± 11.44
ConA	10 <sup>5</sup>	30.6 ± 5.68
None (control 2)	5 × 10 <sup>5</sup>	60.6 ± 10.59
WGA	5 × 10 <sup>5</sup>	36.59 ± 8.91

TABLE 4

Cells of *Ps. fluorescens* adhering after 1 h to 0.03 mm<sup>2</sup> mild steel surface in Medium C plus lectins, with or without sugars

Additions to medium	Original cell concentration/ml	Adherent cells (± S.D.)
ConA (control)	10 <sup>5</sup>	30.6 ± 5.86
ConA + mannose	"	30.52 ± 9.66
ConA + sucrose	"	30.5 ± 6.13
ConA + glucose	"	47.86 ± 15.75
ConA + GlcNAc	"	47.06 ± 8.87
WGA (control)	5 × 10 <sup>5</sup>	36.59 ± 8.91
WGA + GlcNAc	"	57.42 ± 11.27

The results for *D. desulfuricans* are somewhat different (Table 5). Although WGA and ConA inhibit adhesion, this effect cannot be reversed by any of the previously named sugars (data not shown). However, reversal does occur when the disaccharide form of NAG, chitobiose, is used (Table 5).

The inference to be drawn from these results is that *Ps. fluorescens* adhesion is associated with the presence of the sugars glucose and NAG on the cell surface and *D. desulfuricans* adhesion with a di- or polymeric form of NAG. Confirmatory evidence for these conclusions comes from experiments using enzyme-treated cells. Glucosidase, which removes glucose from the cell surfaces, reduces the attachment of *Ps. fluorescens* to mild steel, as does N-acetylglucosaminidase (Table 6). Only N-acetylglucosaminidase is effective for *D. desulfuricans*.

TABLE 5

Cells of *D. desulfuricans* adhering after 1 h to 0.03 mm<sup>2</sup> mild steel surface in Medium C with various additives (Original cell concentration 10<sup>5</sup>/ml)

Additions to medium	Adherent cells (± S.D.)
None (control)	40.13 ± 5.85
ConA	24.9 ± 3.14
WGA	27.44 ± 5.02
ConA + chitobiose	36.9 ± 5.66
WGA + chitobiose	39.4 ± 5.59

TABLE 6

Cells adhering to 0.03 mm<sup>2</sup> mild steel surface in Medium C with or without the enzymes glucosidase and N-acetylglucosaminidase

Organism	Cell concentration/ml	Enzyme treatment	Adherent cells (± S.D.)
<i>Pseudomonas</i>	10 <sup>5</sup>	None (control)	52.23 ± 9.0
		glucosidase 2 u/ml	43 ± 11.69
		" 10 u/ml	41.86 ± 10.23
		" 18 u/ml	35.55 ± 11.48
		GlcNac-ase 1 u/ml	43.8 ± 12.9
		" 5 u/ml	32.8 ± 10.12
" 9 u/ml	25.85 ± 6.43		
<i>Desulfovibrio</i>	8 x 10 <sup>5</sup>	None (control)	53.9 ± 7.63
		glucosidase 18 u/ml	49.2 ± 6.92
		GlcNac-ase 5 u/ml	37.86 ± 9.60

Although these results indicate that glucose and/or NAG are part of bacterial cell surface structures associated with adhesion, they give no information about the type of macromolecule involved. Sugars could be present as either polysaccharide or glycoprotein in the cell wall. In order to differentiate between these two possibilities, further experiments have been carried out. Treatment of *D. vulgaris* (Woolwich) with protease has been shown to remove a major proportion of the outer membrane proteins, whilst leaving LPS relatively unaffected (36). The incubation of cells of *D. desulfuricans* and *Ps. fluorescens* with protease does not influence their ability to adhere to mild steel (data not shown). Cells thus treated are still susceptible to lectin-inhibition of adhesion, implying that the sugar-containing macromolecule involved in adhesion is probably not a glycoprotein, but a polysaccharide.

To confirm this deduction, it is planned to determine the effect of specific antibodies to LPS on cell adhesion to metal. Initial studies testing the influence of monovalent IgG prepared from antiserum raised against extracted *Desulfovibrio* LPS suggest that these antibodies do inhibit adhesion to mild steel. If these results are shown to be reproducible and if it can be shown that a similar effect occurs for *Pseudomonas*, an important interaction in the very first stages of biofilm formation on metal surfaces will have been elucidated.

#### REFERENCES

1. Geesey, G.G., Mutch, R., Costerton, J.W. and Green, R.B. (1978) Sessile bacteria: an important microbial population in small mountain streams. *Limnol & Oceanog.*, 23, 1214-1223.
2. Fletcher, M. (1985) Measurement of glucose utilisation by *Pseudomonas fluorescens* that are free-living and that are attached to surfaces. *Appl. Env. Microbiol.*, 52, 672-676.
3. Gaylarde, C.C. and Johnston, J.M. (1980) The importance of microbial adhesion in anaerobic metal corrosion. In *Microbial Adhesion to Surfaces*, eds, R.C.W. Berkeley, J.M. Lynch, J. Melling, P.R. Rutter and B. Vincent, Ellis Horwood, Chichester, 1980.
4. Gaylarde, C.C. and Johnston, J.M. (1982) The effect of *Vibrio anguillarum* on anaerobic metal corrosion induced by *Desulfovibrio vulgaris*. *Internat. Biodet. Bull.*, 18, 111-116.
5. Gaylarde, C.C. and Videla, H.A. (1987) Localised corrosion induced by a marine vibrio. *Internat. Biodet.*, 23, 91-104.
6. Garcia, M.U., Hubbell, D.H., Gaskins, M.E. and Dazzo, F.B. (1980) Association of *Azospirillum* with grass roots. *Appl. Env. Microbiol.*, 39, 219-226.
7. Schaeffer, A.J., Jones, J. and Dunn, J.K. (1981) Association of in vitro *Escherichia coli* adherence to vaginal and buccal epithelial cells with susceptibility of women to recurrent urinary tract infections. *New Eng. J. Med.*, 304, 1062-1066.
8. Rimes, C.A. and Coulter, R. (1985) A note on the attachment rate of suspended bacteria to submerged aquatic plants on a calcareous stream. *J. Appl. Bacteriol.*, 59, 389-392.
9. Kozody, N.L., Harding, G.K.M., Nicolle, L.E., Kelly, K. and Ronald, A.R. (1985) Adherence of *Escherichia coli* to epithelial cells in the pathogenesis of urinary tract infection. *Clin. Invest. Med.*, 8, 121-125.

10. McCabe, M.M. and Smith, E.E. (1976) in Immunologic Aspects of Dental Caries, eds. W.H. Bowden, R.J. Genco and T.C. O'Brien, Information Retrieval Inc., Washington DC, 1976, p.111.
11. Sequeira, L. and Graham, T.L. (1977) *Physiol. Plant Pathol.* 11, 43.
12. Broughton, W.J. (1978) A review. Control of specificity of legume-*Rhizobium* associations. *J. Appl. Bacteriol.*, 45, 165-194.
13. Dexter, S.C., Sullivan, J.D., Williams, J. and Watson, S.W. (1975) Influence of substrate wettability on the attachment of marine bacteria to various surfaces. *Appl. Microbiol.*, 30, 298-308.
14. Fletcher, M. (1976) The effects of proteins on bacterial attachment to polystyrene. *J. Gen. Microbiol.*, 94, 400-404.
15. Fletcher, M. and Loeb, G.I. (1979) Influence of substratum characteristics on the attachment of a marine pseudomonad to solid surfaces. *Appl. Env. Microbiol.*, 37, 67-72.
16. Kogure, K., Simidu, U. and Taga, N. (1982) Bacterial attachment of phytoplankton in sea water. *J. Exp. Marine Biol. Ecol.*, 56, 197-204.
17. Keevil, C.W., Bradshaw, D.J., Dowsett, A.B. and Feary, T.W. (1987) Microbial film formation; dental plaque deposition on acrylic tiles using continuous culture techniques. *J. Appl. Bacteriol.*, 62, 129-138.
18. Richards, S. and Russell, C. (1987) The effect of sucrose on the colonisation of acrylic by *Candida albicans* in pure and mixed culture in an artificial mouth. *J. Appl. Bacteriol.*, 62, 421-428.
19. Speers, J.G.S. and Gilmour, A. (1985) The influence of milk and milk components on the attachment of bacteria to farm dairy equipment surfaces. *J. Appl. Bacteriol.*, 59, 325-332.
20. Lewis, S.L. and Gilmour, A. (1987) Microflora associated with the internal surfaces of rubber and stainless steel milk transfer pipeline. *J. App. Bacteriol.*, 62, 327-334.
21. Fletcher, M., Latham, M.J., Lynch, J.M. and Rutter, P.R. (1980) The characteristics of interfaces and their role in microbial attachment. In *Microbial Adhesion to Surfaces*, eds. R.C.W. Berkeley, J.M. Lynch, J. Mallng, P.R. Rutter and B. Vincent, Ellis Horwood, Chichester, 1980, pp.67-78.
22. Characklis, W.G. (1981) Fouling biofilm development: A process analysis. *Biotech., Bioeng.*, 23, 1923-1960.
23. Duddridge, J.E. and Prichard, A.M. (1983) Factors affecting the adhesion of bacteria to surfaces. In *Microbial Corrosion*, The Metals Society, London, 1983.
24. Dowling, N.J.E., Guezennec, J. and White, D.C. (1987) Facilitation of corrosion of stainless steel exposed to aerobic seawater by microbial biofilms containing both facultative and absolute anaerobes.

- In Microbial Problems in the Offshore Oil Industry, eds. E.C. Hill, J.L. Shennan and R.J. Watkinson, Wiley & Sons, Chichester, pp.27-38.
25. Nivens, D.E., Nichols, P.D. Henson, J.M., Geesey, G.G. and White, D.C. (1986) Reversible acceleration of corrosion of stainless steel exposed to seawater induced by the extracellular secretions of the marine vibrio *V. natriegens*. *Corr.*, 42, 204-210.
  26. White, D.C., Nivens, D.E., Nichols, P.D., Kerger, B.D., Henson, J.M., Geesey, G.G. and Clarke, C.K. (1985) Corrosion of steels induced by aerobic bacteria and their exocellular polymers, in Proc. Int. Workshop on Biodeterioration held at the University of La Plata, Argentina, March, 1985.
  27. Ford, T.E., Maki, J.S. and Mitchell, R. (1988) Involvement of bacterial exopolymers in biodeterioration of metals, in "Biodeterioration 7", Proc. 7th Int. Biotet. Symp., Cambridge, 1987. Elsevier. In press.
  28. Sutherland, I. (1985) Biosynthesis and composition of Gram negative bacterial extracellular and wall polysaccharides. *Ann. Rev. Microbiol.*, 39, 243-270.
  29. Bradley, G., Gaylarde, C.C. and Johnston, J.M. (1984) A specific interaction between ferrous ions and lipopolysaccharide in *D. vulgaris*. *J. Gen. Microbiol.*, 130, 441-444.
  30. Bradley, G. and Gaylarde, C.C. (1988) Iron uptake by *D. vulgaris* outer membrane components in artificial vesicles. *Current Microbiol.* In press.
  31. Siew, L.K. (1987) An analysis of the outer membrane of *Desulfovibrio vulgaris* (Woolwich) PhD thesis, City of London Polytechnic.
  32. Woolfson, A.D., Gorman, S.P., McCafferty, D.F. and Jones, D.S. (1987) On the statistical evaluation of adherence assays. *J. Appl. Bacteriol.*, 63, 147-151.
  33. Postgate, J.R. (1984) The sulphate-reducing bacteria. Cambridge University Press, Cambridge, 1984.
  34. Heukelekian, H. and Heller, A. (1940) Relation between food concentration and surface for bacterial growth. *J. Bacteriol.*, 40, 547-558.
  35. Jannasch, H.W. (1958) Studies on planktonic bacteria by means of a direct membrane filter method. *J. Gen. Microbiol.*, 18, 609-620.
  36. Bradley, G. (1985) An investigation of the structure and functional aspects of the cell wall of *Desulfovibrio*, PhD thesis, CNAA, City of London Polytechnic.

**BIODETERIORATION SOCIETY  
OCCASIONAL PUBLICATION NO.5**

# **BIOCORROSION**

Proceedings of a joint meeting between the Biodeterioration Society and the French Microbial Corrosion Group held at Le Musée National D'Histoire Naturelle, Paris.

13-14th September 1988

Edited by  
**C.C. Gaylarde and L.H.G. Morton**

## CONTENTS

	Page
<i>Session 1</i>	
Chairpersons: C.C. Gaylarde & J. Guezennec	
1. Corrosion des aciers en milieu géothermique et rôle des bactéries J.J. Honegger, J. Guezennec, A. Criaud, H. Traineau & Ph. Fera	7 - 21
2. Marine bacterial sulphur metabolism on copper-nickel alloys (Abstract only) A.H.L. Chamberlain & C. McDonnell	22
3. Evaluation of the cement degradation induced by the metabolic products of two fungal strains J.V. Perfettini, N. Langomazino, E. Revertegat & J. Le Petit	23 - 36
<i>Session 2</i>	
Chairpersons: M.F. Libert & C.C. Gaylarde	
4. Detection of sulphate-reducing bacteria M. Magot, L. Mondeil, J. Ausseur & J. Seuru	37 - 52
5. Study of biocorrosion inhibitors with electrochemical methods C. Gaboriau-Soubrier & C. Sinicki	53 - 65
<i>Session 3</i>	
Chairpersons: J.L. Honegger & J. Duddridge	
6. Oxidation of cathodic hydrogen linked to sulphite reduction by old cells of <i>Desulfovibrio vulgaris</i> Hildenborough B.S. Rajagopal, L. Duriez, M.F. Libert & J. Legall	66 - 82
7. Interactions between bacteria and copper ions (Abstract only) G. Blunn	83 - 84
8. Bacterial polysaccharides and corrosion C.C. Gaylarde & I.B. Beech	85 - 98
9. Detection of biofilms associated with pitting corrosion of copper pipework in Scottish hospitals C.W. Keevil, J.T. Walker, J. McEvoy & J.S. Colbourne	99 - 117
10. Influence de la protection cathodique sur la croissance des bactéries sulfato-réductrices et sur la corrosion d'aciers les sédiments marines J. Guezennec	118 - 133
11. Evaluation of biofilms by advanced electrochemical monitoring R.A. King & R.D. Eden	134 - 149

CHRISTINE C. GAYLARDE AND IWONA B. BEECH,  
Department of Biological Sciences,  
City of London Polytechnic,  
Old Castle Street, London E1 7NT, UK.

ABSTRACT

Bacterial polysaccharides have been implicated in corrosion as lipopolysaccharides (LPS) in the cell wall, enhancing cell adhesion to the metal surface, and as extracellular polymeric substances (EPS), incorporating into biofilms and encouraging differential aeration cell formation.

The initial colonisation and subsequent biofilm formation on mild steel surfaces in pure and mixed cultures of *Pseudomonas fluorescens* and *Desulfovibrio desulfuricans* was studied using fluorescence microscopy, scanning electron microscopy and EDAX analysis. Adhesion of cells to the metal surface after 1 h has been shown by the use of specific sugar antagonists and glycolytic enzymes to be related to the presence of N-acetyl glucosamine and, in the case of *P. fluorescens* only, glucose on the cell surfaces. The inhibition of adhesion by specific antibodies to LPS indicated that these surface sugars were probably present as polysaccharide side chains of LPS.

In spite of the initial more rapid adhesion of *P. fluorescens* cells, *D. desulfuricans* produced a complete biofilm on the metal surface more quickly. Within six weeks mild steel surfaces incubated with *D. desulfuricans*, either alone or in combination with *P. fluorescens*, were completely obscured by a biofilm consisting of bacterial cells, EPS and corrosion products. After the same period, *P. fluorescens* incubated metal surfaces showed only patchy accumulations of cells with no apparent EPS or corrosion products and large areas of bare metal. EDAX analysis demonstrated the presence of large amounts of sulphur in the *D. desulfuricans* biofilm and lesser quantities in biofilms on mild steel incubated with mixed cultures of *D. desulfuricans* and *P. fluorescens*, thus confirming the production of sulphide-containing corrosion products in these two environments.



## Polysaccharides bactériens et corrosion

Les polysaccharides bactériens interviennent dans les problèmes de corrosion sous forme des lipopolysaccharides (LPS) constituant la paroi, permettant l'adhésion de la cellule aux surfaces métalliques, et sous forme de polymères extracellulaires.

La colonisation initiale à la surface d'un acier doux et la formation ultérieure du biofilm par des cultures pures ou mixtes de *Pseudomonas fluorescens* et *Desulfovibrio desulfuricans* sont ici étudiées au moyen de la microscopie de fluorescence, de la microscopie électronique à balayage et de l'analyse EDAX. Au moyen de sucres spécifiques antagonistes et d'enzymes glycolytiques, l'adhésion des cellules sur une surface métallique est corrélée à la présence de N-acetyl glucosamine et dans le cas de *Pseudomonas fluorescens* seul à la présence de glucose à la surface de la cellule. L'inhibition de l'adhésion par des anticorps spécifiques des LPS indiquent que ces sucres de surface sont présents au sein des structures lipopolysaccharidiques. Malgré l'adhésion initiale plus rapide des cellules de *P. fluorescens*, les cellules de *D. desulfuricans* produisent un biofilm à la surface métallique plus rapidement. Après six semaines d'incubation de coupons d'acier avec des cellules de *D. desulfuricans*, ceux-ci sont complètement recouverts par un biofilm constitué de bactéries, de polymères extracellulaires et de produits de corrosion. Dans le cas des cellules de *P. fluorescens*, les coupons métalliques présentent une répartition inégale de cellules, sans polymères extracellulaires ni produits de corrosion et de larges surfaces de métal à nu. L'analyse EDAX indique la présence de grandes quantités de soufre au sein du biofilm, de *D. desulfuricans* et de plus faibles quantités dans les biofilms de cultures mixtes de *D. desulfuricans* et *P. fluorescens*. Ceci confirme la production de produits de corrosion contenant du sulfure dans ces deux environnements.

Les polysaccharides bactériens interviennent dans les problèmes de corrosion sous forme des lipopolysaccharides (LPS) constituant la paroi, permettant l'adhésion de la cellule aux surfaces métalliques, et sous forme de polymères extracellulaires.

La colonisation initiale à la surface d'un acier doux et la formation ultérieure du biofilm par des cultures pures ou mixtes de *Pseudomonas fluorescens* et *Desulfovibrio desulfuricans* sont ici étudiées au moyen de la microscopie de fluorescence, de la microscopie électronique à balayage et de l'analyse EDAX. Au moyen de sucres spécifiques antagonistes et d'enzymes glycolytiques, l'adhésion des cellules sur une surface métallique est corrélée à la présence de N-acetyl glucosamine et dans le cas de *Pseudomonas fluorescens* seul à la présence de glucose à la surface de la cellule. L'inhibition de l'adhésion par des anticorps spécifiques des LPS indiquent que ces sucres de surface sont présents au sein des structures lipopolysaccharidiques. Malgré l'adhésion initiale plus rapide des cellules de *P. fluorescens*, les cellules de *D. desulfuricans* produisent un biofilm à la surface métallique plus rapidement. Après six semaines d'incubation de coupons d'acier avec des cellules de *D. desulfuricans*, ceux-ci sont complètement recouverts par un biofilm constitué de bactéries, de polymères extracellulaires et de produits de corrosion. Dans le cas des cellules de *P. fluorescens*, les coupons métalliques présentent une répartition inégale de cellules, sans polymères extracellulaires ni produits de corrosion et de larges surfaces de métal à nu. L'analyse EDAX indique la présence de grandes quantités de soufre au sein du biofilm, de *D. desulfuricans* et de plus faibles quantités dans les biofilms de cultures mixtes de *D. desulfuricans* et *P. fluorescens*. Ceci confirme la production de produits de corrosion contenant du sulfure dans ces deux environnements.

Polysaccharides are important constituents of bacterial surface structures, forming varying proportions of capsules, Gram positive cell walls and Gram negative outer membranes. With the latter, polysaccharides, in the form of lipopolysaccharides (LPS), comprise the interface between the bacterial cell and its surrounding environment (Fig. 1). The polysaccharide side chains of LPS project from the cell surface and facilitate interactions between the cell and adjacent cells (Peterson & Quie, 1981) or with extracellular materials such as cations (Leive et al, 1968). Such interactions could be important in the corrosion of metals, which is an electrochemical phenomenon occurring at the metal/solution/cell interface (Videla, 1988). LPS could enhance corrosion in two ways: by chelating metal ions, thus allowing further dissolution of the solid metal (i.e. by altering the equilibrium of the equation  $M \rightleftharpoons M^+$ ) and by acting as adsorption structures, allowing adhesion of bacterial cells to the metal surface with resulting oxygen concentration cell formation and subsequent corrosion (Tiller, 1983). It has been shown that the attachment of cells of the sulphate-reducing bacterium *Desulfovibrio vulgaris* to a metal surface is necessary for the production of the rapid corrosion associated with this group of organisms (Gaylarde and Johnston, 1980). In addition, Gaylarde and Videla (1987) have demonstrated the severe pitting corrosion occurring on mild steel beneath adherent colonies of the marine bacterium *Vibrio alginolyticus*. There can be little doubt that the adhesion of bacterial cells and the concomitant build-up of a biofilm can induce rapid metal corrosion.

Microbial biofilms are complex structures consisting not only of bacterial cells but also of extracellular materials (waste metabolic products and excreted polymers) and, on a metal surface, corrosion products. Excreted polymers (extracellular polymeric substances, EPS) are mainly polysaccharide in nature and have a range of important biological functions including attachment, protection and nutrient uptake (Costerton et al, 1978). It has been shown that bacterial EPS can selectively bind metal ions (see, for example, Friedman and Dugan, 1968). Mittleman and Geesey (1985) have suggested that a bacterial exopolymer, which they had demonstrated to bind copper, could form copper-concentration cells on a copper alloy surface, thus promoting oxidation of less noble metals. Ford et al (1987) have isolated a thermophilic bacterium from corroded nickel tubing and shown that the exopolymers produced by this organism bind copper and,

Figure 11

**Diagrammatic representation across a Gram Negative Bacterial Outer Membrane and of a Typical Lipopolysaccharide Molecule**

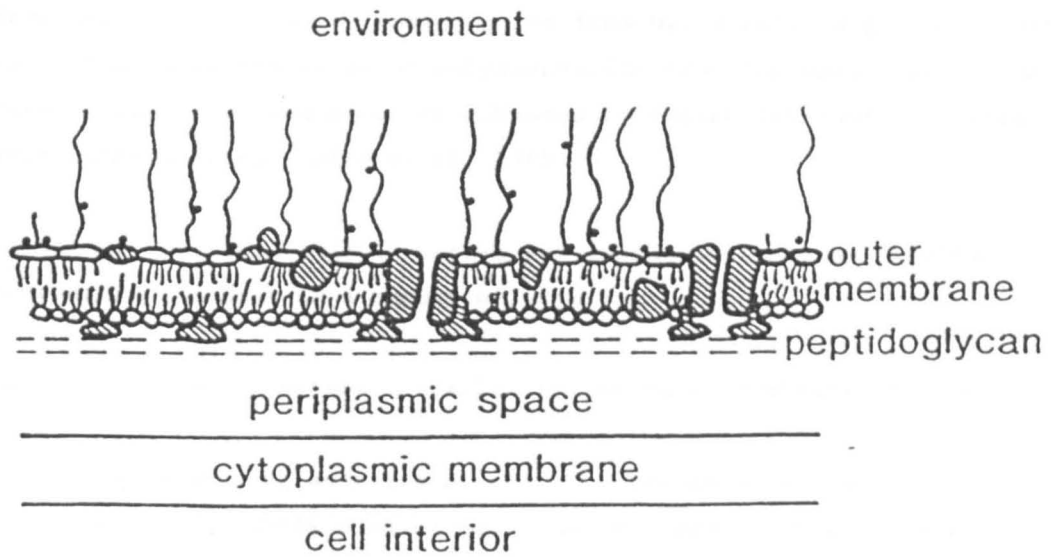

- KEY
- metal cation
  - ◐ phospholipid
  - ◑ lipopolysaccharide
  - ◒ protein
  - ◓ lipoprotein

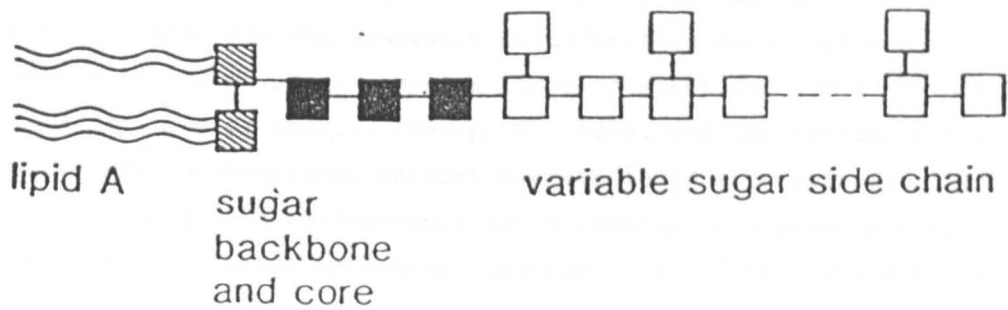

furthermore, accelerate the corrosion of various metals, probably by the formation of copper concentration cells (Little et al, 1987). Later work by Ford and his co-workers (Ford et al, 1988) has demonstrated that exopolymers from different bacteria and even from the same bacterial species under varying conditions have different metal-binding abilities. In particular, exopolymer from planktonic *Thermus* sp. binds much less copper than that from sessile organisms. This *Thermus* sp. has also been shown to accelerate corrosion. The LPS of *D. vulgaris* has been shown to bind ferrous ions selectively (Bradley et al, 1984) and similar corrosion mechanisms may be postulated in this case. Further evidence for the involvement of EPS in corrosion comes from David White's group. They have shown that the excreted polysaccharide from the marine bacterium *Pseudomonas atlantica* produces enhanced corrosion rates of stainless steel over control rates (White et al, 1985).

It is apparent then that bacterial polysaccharides may be important in corrosion processes in a number of ways -

- (a) As LPS in the external leaflet of the outer membrane of Gram negative cells
  - (i) enhancing adhesion of cells to the metal surface
  - (ii) selectively binding metal cations and so accelerating corrosion
  
- (b) As EPS excreted from bacterial cells
  - (i) enhancing adhesion of the excreting cells and of other cells in the vicinity to the metal surface to form a biofilm
  - (ii) chelating metal ions or otherwise promoting corrosive processes.

This presentation reports the initial results of experiments undertaken to define the importance of LPS and EPS of two widely differing bacterial genera in adhesion to metal surfaces and the concomitant corrosion. The bacteria chosen are the anaerobic *Desulfovibrio desulfuricans*, New Jersey, a member of the sulphate-reducing bacteria group and hence an important corrosion-inducing species (Postgate, 1984), and the aerobic *Pseudomonas fluorescens*, a ubiquitous bacterium often found as a primary coloniser of surfaces in aqueous environments and belonging to a genus previously associated with metal corrosion (Obuekwe et al, 1981; White et al, 1985).

## METHODS

*D. desulfuricans* New Jersey (NCIMB 8313) was grown in Postgate's Medium C (Postgate, 1984).

*P. fluorescens*, isolated from a contaminated metal-working fluid, was grown on nutrient agar and resuspended in Medium C for adhesion experiments. For studies on biofilm formation the cells were grown in Medium C.

Specific antibodies were raised in New Zealand White rabbits by intramuscular injection with extracted LPS from either species of bacteria. Two injections were given at weekly intervals and the serum separated from blood taken one week after the last injection. Immunoglobulins were partially purified from the sera by salt precipitation (Siew, 1987) and were freeze-dried.

The influence of the immunoglobulins on the adhesion of bacterial cells to mild steel was investigated by incubating stubs composed of mild steel (BS970) in Medium C plus approximately  $10^8$  bacterial cells/ml with or without cell pre-treatment for 1.5 h with 400  $\mu$ g/ml immunoglobulin or salt-precipitate from normal rabbit serum. The numbers of cells adhering after 1 h were determined by fluorescence microscopy of specimens stained with 0.001% acridine orange.

Biofilm formation on mild steel was studied by SEM and EDAX. Stubs were incubated as above in Medium C containing one or both bacterial genera (inoculum  $10^5$  cells/ml of each type) for up to eight weeks. At defined intervals, stubs were removed, rinsed in cacodylate buffer, fixed in glutaraldehyde and post-fixed in osmium tetroxide. After dehydration through an isopropanol-water series, samples were freeze-dried, mounted on aluminium stubs and sputter-coated with gold ready for observation in the SEM. EDAX was performed on unfixed and uncoated samples using a Super-Mini SEM equipped with an energy-dispersive X-ray analyser (Lewell Electronics Ltd).

It has previously been reported (Gaylarde and Beech, 1988) that the adhesion of *P. fluorescens* to mild steel is inhibited by the lectins concanavalin A and wheat germ agglutinin and that this inhibition is reversed by the sugars glucose and N-acetyl glucosamine. The inference drawn from these results, that *P. fluorescens* adhesion is associated with the presence of glucose and N-acetyl glucosamine on the cell surface, was substantiated by the results of enzyme treatments. Glucosidase and N-acetyl glucosaminidase both reduced *P. fluorescens* adhesion to mild steel. In the case of *D. desulfuricans* New Jersey, similar experiments indicated that N-acetyl glucosamine only was involved in this adhesion.

For both bacterial species, protease treatments did not affect adsorption, suggesting that the sugars involved in adhesion are not present as glycoproteins, but rather as LPS or EPS associated with the bacterial cells (Gaylarde and Beech, 1988). Glucose and N-acetyl glucosamine have been shown to be the main sugar components of the EPS of *Pseudomonas* spp. (O'Neill et al, 1983; Wrangstadh et al, 1986) and glucosamine has been detected in the LPS of *Desulfovibrio* sp. (Siew, 1987), hence both LPS and EPS are good candidates for adsorption-relation molecules.

In the present study, immunoglobulins precipitated from antisera raised against the LPS of each of the bacterial species and of the related sulphate-reducing bacterium *Desulfovibrio vulgaris* Woolwich were shown to inhibit adhesion of homologous or related cells to mild steel (Tab. 1). The adsorption of *D. desulfuricans* cells was reduced by treatment with antibodies against the LPS of either *D. desulfuricans* or *D. vulgaris*, but not by treatment with normal rabbit serum or with antibodies raised against *P. fluorescens* LPS. Similarly, *P. fluorescens* adhesion was inhibited by antibodies to homologous LPS, but not by anti-*Desulfovibrio* LPS or normal rabbit serum.

These results would seem to indicate that the structures important in adhesion of *P. fluorescens* and *D. desulfuricans* to mild steel are the polysaccharide side chains of LPS. However, Sutherland (1985) has stated that it is often difficult to distinguish between truly structural polysaccharide, present as LPS in the outer membrane, and excreted polysaccharide (EPS) in transit through the cell wall. It is therefore

TABLE 1: Numbers of bacterial cells adhering to mild steel within one hour following preincubation of cells with specific antibodies for 1.5 hours.

<u>Bacterial species</u>	<u>Preincubation with:</u>	<u>Mean number of cells adhering to 0.03mm<sup>2</sup> ± S.D.</u>
<i>D. desulfuricans</i>	Medium C only	48.05 ± 7.83
	NRS	50.7 ± 12.4
	A-LPS <sub>PF</sub>	49.9 ± 5.98
	A-LPS <sub>DD</sub>	33.4 ± 8.9
	A-LPS <sub>DV</sub>	31.4 ± 8.21
<i>P. fluorescens</i>	Medium C only	50.02 ± 8.76
	NRS	50.12 ± 6.88
	A-LPS <sub>PF</sub>	29.0 ± 4.37
	A-LPS <sub>DD</sub>	49.7 ± 8.2
	A-LPS <sub>DV</sub>	50.7 ± 7.02

NRS Normal rabbit serum  
A-LPS<sub>PF</sub> Antibody to *P. fluorescens* LPS  
A-LPS<sub>DD</sub> Antibody to *D. desulfuricans* LPS  
A-LPS<sub>DV</sub> Antibody to *D. vulgaris* LPS



important to isolate and analyse EPS from the two bacterial species used in this study and this is at present under way.

Any EPS produced will form part of the biofilm produced by the bacteria. SEM studies of biofilm formed on mild steel stubs incubated with pure or mixed cultures of bacteria gave widely differing results. In the early stages of colonisation, *P. fluorescens* attached more readily to the mild steel surface than *D. desulfuricans* (Gaylarde and Beech, 1988), but after six weeks *P. fluorescens* incubated stubs were only patchily colonised, with areas of bare metal still visible (Fig. 2). There was little apparent biofilm. On the other hand, *D. desulfuricans* incubated stubs viewed after six weeks showed an almost complete covering of biofilm consisting of bacterial cells, EPS and corrosion products (Fig. 3). EDAX analysis showed that the major elements in this biofilm were iron and sulphur, presumably present as iron sulphides. High quantities of sulphur were also detected in biofilms formed in mixed cultures of *D. desulfuricans* and *P. fluorescens*, but not in biofilms on mild steel surfaces incubated with *P. fluorescens* alone. This confirms that *P. fluorescens*, a non-sulphate-reducing bacterium, does not induce the production of corrosive iron sulphides. In view of earlier work showing enhanced sulphide film formation and associated corrosion in mixed as compared with pure cultures of SRB (Gaylarde and Johnston, 1982; Gaylarde and Videla, 1987), it is interesting to note that in the current study sulphur is present in larger quantities in biofilms formed in the presence of pure *D. desulfuricans* than in those produced in mixed *Pseudomonas-Desulfovibrio* cultures. This serves to emphasise the importance of the species of associated bacteria in mixed SRB-induced corrosion, as has been previously demonstrated (Gaylarde and Johnston, 1986).

EDAX analysis also showed that the content of phosphorus in the biofilm varied with environment. It has been suggested that the corrosive activity of SRB is due to the production of a reduced phosphorus compound (Iverson and Olson, 1983). In the present study, phosphorus was found to be present in greatest amount on mild steel stubs which had been incubated in Medium C without any bacterial cells. This does not appear to confirm the relationship of phosphorus to the intense corrosion induced by SRB.

Figure 2

Scanning electron micrograph of mild steel surface after 4 weeks' incubation in Medium C plus P. fluorescens. Note large areas of bare metal. Occasional inorganic crystals are also seen.



Figure 3

Scanning electron micrograph of mild steel surface after 4 weeks' incubation in Medium C plus D. desulfuricans. Note large numbers of bacterial cells and string-like EPS. Clumps of granular corrosion product are also visible.



The early colonisation of mild steel by *D. desulfuricans* and *P. fluorescens* is associated with cellular surface structures containing N-acetyl glucosamine and, in the case of *P. fluorescens*, glucose. These structures are probably the polysaccharide side chains of LPS, but may occur in excreted polysaccharides (EPS) present transiently in the cell outer membranes.

Following initial cell adhesion to the mild steel, *D. desulfuricans* rapidly causes the build-up of a biofilm consisting of bacterial cells, EPS and corrosion products. This biofilm completely obscures the metal surface. *P. fluorescens*, in spite of an initial rapid adherence, produces an incomplete biofilm over the same timescale. Patchy accumulations of cells with no apparent EPS or corrosion products are found on the mild steel surface. Work is at present under way to quantify the degree of corrosion associated with these adherence phenomena.

## REFERENCES

- BRADLEY, G., GAYLARDE, C. and JOHNSTON, J. (1984) A specific interaction between ferrous ions and lipopolysaccharide in *D. vulgaris*. *Journal of General Microbiology* 130, 441-444.
- COSTERTON, J.W., GEESEY, G.G. and CHENG, K.J. (1978) How bacteria stick. *Scientific American* 238, 86-95.
- FORD, T.E., MAKI, J.S., BLACK, J.P. and MITCHELL, R. (1987) Corrosion of metals by thermophilic microorganisms. *Materials Performance* 26, 35-39.
- FORD, T.E., MAKI, J.S. and MITCHELL, R. (1988) Involvement of bacterial exopolymers in biodeterioration of metals. *In* "Biodeterioration 7", eds. D. Houghton, R.N. Smith and H.O.W. Egging, Elsevier Applied Science, Barking, Essex, pp.378-384.
- FRIEDMAN, B.A. and DUGAN, P.R. (1968) Concentration and accumulation of metallic ions by the bacterium *Zoogloea*. *Developmental and Industrial Microbiology* 9, 381-388.
- GAYLARDE, C.C. and BEECH, I.B. (1988) Molecular basis of bacterial adhesion to metals *in* "Microbial Corrosion I", eds. C.A.C. Sequeira and A.K. Tiller, Elsevier Applied Science, pp.20-28.
- GAYLARDE, C.C. and JOHNSTON, J.M. (1980) The importance of microbial adhesion in anaerobic metal corrosion. *In* "Microbial Adhesion to Surfaces" eds. R.C.W. Berkeley, J.M. Lynch, J. Melling, P.R. Rutter and B. Vincent, Ellis Horwood, Chichester, pp.117-118.
- GAYLARDE, C.C. and JOHNSON, J.M. (1982) The effect of *Vibrio anguillarum* on the anaerobic corrosion of mild steel by *Desulfovibrio vulgaris*. *International Biodeterioration Bulletin* 18, 111-116.
- GAYLARDE, C.C. and JOHNSON, J.M. (1986) Anaerobic metal corrosion in cultures of bacteria from estuarine sediments. *In* "Biologically Induced Corrosion", NACE-8 International Conference Series, Houston, Texas, NACE pp.137-143.

- GAYLARDE, C.C. and VIDELA, H.A. (1987) Localised corrosion induced by a marine *Vibrio*. *International Biodeterioration* 23, 91-104.
- IVERSON, W.P. and OLSON, G.J. (1983) Anaerobic corrosion by sulfate-reducing bacteria due to highly reactive volatile phosphorus compound. *In* "Microbial Corrosion", The Metals Society, London, pp.46-53.
- LEIVE, L., SHOUKIN, V.K. and MERGENHAGEN, S.E. (1968) Physiological, chemical and immunological properties of LPS released from *E. coli* by EDTA. *Journal of Biological Chemistry* 243, 6384-6391.
- LITTLE, B., WAGNER, P., GERCHAKOV, S.M., WALCH, M. and MITCHELL, R. (1986) The involvement of a thermophilic bacterium in corrosion processes. *Corrosion* 42, 533-536.
- MITTLEMAN, M.W. and GEESEY, G.G. (1985) Copper-binding characteristics of exopolymers from a freshwater sediment bacterium. *Applied and Environmental Microbiology* 49, 846-851.
- OBUEKWE, C.O., WESTLAKE, D.W.S., COOK, F.D. and COSTERTON, J.W. (1981) Surface changes in mild steel coupons from the action of corrosion causing bacteria. *Applied and Environmental Microbiology* 41, 766-774.
- O'NEILL, M.A., SELVENDRAN, R.R. and MORRIS, V.J. (1983) Structure of the acidic extracellular gelling agent polysaccharide produced by *Pseudomonas elodea*. *Carbohydrate Research* 124, 123-133.
- PETERSON, P.K. and QUIE, P.G. (1981) Bacterial surface components and the pathogenesis of infectious diseases. *Annual Review of Medicine* 32, 29-43.
- POSTGATE, J.R. (1984) *The Sulphate-reducing Bacteria*. Cambridge University Press, Cambridge, UK.
- SIEW, L.K. (1987) An analysis of the outer membrane of *Desulfovibrio vulgaris* Woolwich. Ph.D. thesis, CNAAC, City of London Polytechnic.

SUTHERLAND, I.W. (1985) Biosynthesis and composition of Gram-negative bacterial extracellular and wall polysaccharides. Annual Reviews of Microbiology 39, 243-270.

TILLER, A.K. (1983) Electrochemical aspects of corrosion: an overview. In "Microbial Corrosion", The Metals Society, London.

VIDELA, H.A. (1988) An electrochemical interpretation of the role of microorganisms in corrosion. In "Biodeterioration 7", eds. D. Houghton, R.N. Smith and H.O.W. Egging. Elsevier Applied Science, Barking, Essex, pp.359-371.

WHITE, D.C., NIVENS, D.E., NICHOLS, P.D., KERGER, B.D., HENSON, J.M., GEESEY, G.G. and CLARKE, C.K. (1986) Corrosion of steels induced by aerobic bacteria and their exocellular polymers. Proc. International Workshop on Microbially Induced Corrosion, University of La Plata, March 1985. Aquatec Quimica, Sao Paulo, Brazil.

WRANGSTADH, M., CONWAY, P.L. and KJELLBERG, S. (1986) The production and release of an extracellular polysaccharide during starvation of a marine *Pseudomonas* sp. and the effect thereof on adhesion. Archives of Microbiology 145, 220-227.

**In preparation:**

- 1/ Moreno, D.A., Ibars, J.I., Beech, I.B. and C.C. Gaylarde. 1990. Biofilm formation on mild steel coupons by Pseudomonas and Desulfovibrio. Biofouling. In press.
- 2/ Beech, I.B., Gaylarde, C.C., Smith, J.J. and Geesey, G.G. 1990. Carbohydrate analysis of biofilms and exopolymers from Desulfovibrio desulfuricans and Pseudomonas fluorescens in the presence of mild and stainless steel. In preparation.
- 3/ Beech, I.B. and Gaylarde, C.C. 1990. Microbial polysaccharides and corrosion. Meeting of the Biodeterioration Society, Nottingham, April 9-10, 1990. In press.