

TRANSFORMER LOAD TAP CHANGER CONTROL USING
IEC 61850 GOOSE MESSAGING

By

Nelli Sichwart

Approved:

Ahmed H. Eltom
Professor of Electrical Engineering
(Director of Thesis)

Gary Kobet
Adjunct Professor of Electrical Engineering
(Committee Member)

Stephen Craven
Assistant Professor of Electrical Engineering
(Committee Member)

William H. Sutton
Dean of the College of Engineering and
Computer Science

A. Jerald Ainsworth
Dean of the Graduate School

TRANSFORMER LOAD TAP CHANGER CONTROL USING
IEC 61850 GOOSE MESSAGING

By

Nelli Sichwart

A Thesis
Submitted to the Faculty of the
University of Tennessee at Chattanooga
in Partial Fulfillment of the Requirements
for the Degree of Master of Science
in Electrical Engineering

The University of Tennessee at Chattanooga
Chattanooga, Tennessee

May 2012

ABSTRACT

The research of this thesis implements Load Tap Changer (LTC) control using the International Electrotechnical Commission (IEC) 61850 standard in a laboratory environment. In particular, Generic Object Oriented Substation Event (GOOSE) messages are used to facilitate all required communication. A set of two Schweitzer Engineering Laboratories, Inc. (SEL) devices is used for the demonstration.

IEC 61850 has many benefits including great flexibility and improved interoperability and promises to be more widely implemented in the United States with time as is already the case in many other parts of the world.

This research shows that LTC operation using IEC 61850 is reliable and brings with it all the benefits that the implementation of IEC 61850 has to offer. Above all, due to elimination of the majority of copper wiring, the proposed method is very flexible and can be implemented using a variety of different devices.

TABLE OF CONTENTS

LIST OF TABLES	vi
LIST OF FIGURES	vii
LIST OF ABBREVIATIONS	viii
CHAPTER	
1. INTRODUCTION	1
Load Tap Changer Control Today	1
IEC 61850 General Overview	2
Advantages of IEC 61850	3
IEC 61850 GOOSE Overview	5
2. LTC CONTROL USING GOOSE MESSAGES	6
Objective and Brief Description	6
Justification	6
Prior Art	7
3. LTC OPERATION SIMULATION	8
Transformer	8
Overall System	9
Merging Unit Function	11
Processing Function	11
Actuator Module Function	18
4. TESTING	19
Test Setup and Procedure	19
Test Results	22
5. DISCUSSION	26
Evaluation of Test Results	26
Reliability	26

Advantages of Proposed LTC Control	28
6. CONCLUSIONS	29
REFERENCES	31
VITA	32

LIST OF TABLES

4.1	Summary of Tap-Raise Simulation Results.....	23
4.2	Summary of Tap-Lower Simulation Results.....	24

LIST OF FIGURES

1.1	Substation Wiring Today (left) and in the Future (right)	5
3.1	LTC Model	9
3.2	Overall System Configuration	10
3.3	Picture of Laboratory Setup	10
3.4	Complete LTC Control Logic	13
3.5	LTC Control Turn On/Off Function	14
3.6	Tap Raise Function	14
3.7	Tap Lower Function	16
3.8	Tap Position Calculation Function	17
4.1	State Sequencer States for Tap-Raise Simulation	20
4.2	Tap-Raise Simulation Time Assessment	20
4.3	State Sequencer States for Tap-Lower Simulation	21
4.4	Tap-Lower Simulation Time Assessment	21
4.5	Tap-Raise Simulation Results	22
4.6	Tap-Lower Simulation Results	23
6.1	Picture of Used Devices	29

LIST OF ABBREVIATIONS

LTC, Load Tap Changer

IEC, International Electrotechnical Commission

GOOSE, Generic Object Oriented Substation Event

SEL, Schweitzer Engineering Laboratories, Inc.

VRR, Voltage Regulator Relay

SCADA, Supervisory Control And Data Acquisition

IED, Intelligent Electronic Device

MU, Merging Unit

AM, Actuator Module

OLTC, On-Load Tap Changer

CID, Configured IED Description

LAN, Local Area Network

VT, Voltage Transformer

CHAPTER 1

INTRODUCTION

Load Tap Changer Control Today

A Load Tap Changer (LTC) is a mechanism internal to many transformers, especially high-voltage transformers, that can change the number of turns used in a transformer winding by selecting from a given number of available taps on that winding. It is located on one side of the transformer and functions to adjust the secondary transformer voltage to maintain it at a particular desired voltage level.

Today, there are three ways to control the Load Tap Changer (LTC). One, the LTC can be controlled using a designated device, the Voltage Regulator Relay (VRR) which is currently the most common method for many utilities. According to the Standard IEEE C37.2, the device number for the VRR is 90 [1]. Two, it can be controlled directly by the operator from the control center via the Supervisory Control And Data Acquisition (SCADA) system. Three, the LTC control can be integrated into a multifunctional device which many protection and automation Intelligent Electronic Devices (IEDs) are today. It is most common to have the VRR in the control box next to the transformer. Often it is set up such that the control can be switched between local and remote, that is between control at the substation and at the control center respectively. If it is integrated into another IED, it may be located in the control house. As an additional backup option, the LTC can be operated manually at the transformer but is not used as the primary operating option.

IEC 61850 General Overview

IEC 61850 is a standard developed by the IEC's Technical Committee 57 (TC57). It specifies guidelines for communication between IEDs for the automation of substations. Although initially limited to the application within substations, it is being expanded to include substation-to-substation communication, substation-to-control center communication and communication systems for hydroelectric power plants, distributed energy resources, wind turbines and others. [2]

IEC 61850 suggests specified ways to model substation IEDs to facilitate the communication between them. It is a set of conceptual rules which are independent of any particular current products, operating systems, programming languages, middleware, communication systems or vendors. [2]

IEDs are modeled as a set of logical nodes according to the IED's functional decomposition. Each logical node has multiple data groups and each data group has multiple data attributes. An example of a logical node is the circuit breaker with the logical node name "XCBR". One of the data groups of this node is "Position" and one of the data attributes of this data group is "Status value". [2]

IEC 61850 encompasses the strong points of the OSI 7-layer communication model. The two key message types, namely Generic Object Oriented Substation Event (GOOSE) and Sampled Values, are mapped using the bottom two layers, namely Data Link and Physical Layer. The client-server communication is mapped using all 7 layers. GOOSE messages are used for multicast peer-to-peer communication between IEDs and communication between IEDs and the substation computer. GOOSE messages are event-driven and not published on one specific time interval. Sampled Values messages are used for communication between

substation equipment and IEDs. Sampled Values messages are used to communicate measurements and status information from substation equipment in regular time intervals. [2]

Advantages of IEC 61850

The IEC 61850 standard offers many benefits to the current power system especially in the long run. It is the vision of many people today that in the future the substation will be run by a centralized real-time computer. Merging Units (MUs) will interface with analog signals (voltage measurements, current measurements, signals from various mechanical sensors, etc.) and communicate these digitally over an Ethernet network in the form of Sampled Values or GOOSE messages. Actuator Modules (AMs) will implement control action after receiving GOOSE messages from the computer. All decision-making will be done by one centralized computer. The computer will be substation-hardened, run a real-time operating system and have software to run the different applications. [2]

Compared to today's substation, the benefits of the full implementation of IEC 61850 are significant.

First, wiring can be greatly reduced. Because Merging Units (MUs) and Actuator Modules (AMs) can be placed in close proximity of the physical devices and remaining communication is done over Ethernet, wiring can be significantly reduced. This eliminates the need for engineers to design circuitry as well as for technicians to install it which in turn saves time and money. However, in the transition to the full implementation of the standard training will need to be provided to technicians and field engineers because different skill sets are required to operate and troubleshoot an IEC 61850-based system compared to today's practices. In addition, with significantly reduced wiring, the risk for the occurrence of an open circuit which poses a danger to people and equipment is reduced. Also, copper is a limited

natural resource and is becoming increasingly expensive. With networked communication far less copper for wiring is needed. [2]

Second, flexibility can be greatly improved. Because additional applications would be implemented by purchasing and adding software, the only changes that may be necessary are the addition of MUs or AMs. These are likely to be relatively small and less expensive devices in the future. Most changes can be implemented by merely installing software and adding and/or changing settings. Improved flexibility opens doors for improving quality and reliability as well. [2]

Third, with time, the implementation of the standard will yield a reduction in number and complexity of necessary devices. With the implementation of MUs, measurements are taken and converted to data once and communicated to all devices or applications interested in that information. However, today a connection is provided to each relay and each relay does the conversion using internal transformers, filters, multiplexers and analog-to-digital converters itself. MUs and AMs will be relatively simple devices with communication capabilities and it will be possible to group the functions of more and more IEDs into a single device. [2]

Fourth, reducing wiring and the number and complexity of devices will reduce time and money needed for labor for installation as mentioned above, but also for maintenance and repairs. [2]

Fifth, interoperability is achieved. As with time all vendors will support the IEC 61850 protocol, and software to manage the overall configuration will mature, all devices will be able to interoperate which allows for more flexibility and greater competitiveness. By standardizing the object models as specified by IEC 61850 interoperability between various applications is possible. [2]

Eventually what is shown below on the left in Figure 1.1 will be replaced by what is shown below on the right.



Figure 1.1 Substation Wiring Today (left) and in the Future (right)

IEC 61850 GOOSE Overview

With GOOSE messages, a set of data attributes combined in a dataset can be communicated. The device that has information of interest publishes this information in a GOOSE message in a multi-cast manner to the network. This device does not target particular recipients but only delivers the message to the network and repeats it per standard specification. Other devices subscribe to and read the GOOSE message to retrieve the information. The subscription has to be configured using software that manages the overall IEC 61850 communication setup. After initial sending of a GOOSE message, the source device resends the GOOSE message in intervals of increasing duration until a maximum repetition interval is reached at which the message is repeated until the data attributes change and a new GOOSE message is formed.

CHAPTER 2

LTC CONTROL USING GOOSE MESSAGES

Objective and Brief Description

The objective of the proposed method is to implement LTC control using key elements of IEC 61850. These key elements include a Merging Unit (MU) that provides voltage measurements to the control unit using IEC 61850 GOOSE, and an Actuator Module (AM) that operates the LTC motor and receives the command to do so from the control unit using IEC 61850 GOOSE as well.

Justification

The status of IEC 61850 implementation in the United States today is that the application of GOOSE messaging is progressing to penetrate the industry but the application of Sampled Values messaging has not begun to penetrate the industry significantly. It is still a vision to see IEC 61850 be implemented in its full scope.

It is the goal of this research to accomplish LTC control using IEC 61850. Ideally, the voltage measurements should be communication via Sampled Values messages. However, many IEDs still do not support this feature as is the case with the devices used for this research. Therefore, GOOSE messaging is used instead to accomplish the goal of operating mainly with networked communication versus copper cable. This is a viable option for LTC control because it is not time critical. In fact, operation is delayed intentionally to avoid unnecessary actions due to brief variations in voltage. However, one scenario is that if LTC control is implemented in a

transformer protection IED which utilizes current measurements only, that is it does not connect to a voltage transformer, the voltage measurements necessary for LTC control could be received from a device that does connect to the voltage transformer. Also, the proposed method could be applied as a redundant system to the existing system assuming that the available devices have IEC 61850 capabilities.

Prior Art

A paper published at the 10th International Conference on Developments in Power System Protection (DPSP 2010) presents the experience of a European utility with using IEC 61850 GOOSE messages for the control of parallel transformers with On-Load Tap Changers (OLTCs). Each transformer has its own IED for protection and control which also includes the LTC control. It is understood that each IED is directly wired to current and voltage instrument transformers but that particular calculated voltage values, current values and other information as needed for the proposed operation are communicated via IEC 61850 GOOSE messages. [3]

Also, at the 2010 20th Australasian Universities Power Engineering Conference (AUPEC) a paper proposes two methods for the coordination of multiple OLTCs that are in series with each other. The authors propose to use GOOSE messages to transmit “blocking, releasing and helping signal[s]” that are necessary for the coordination of multiple OLTCs. [4]

In both found cases, LTC control relies on voltage measurements that come from a direct connection between the controlling device and the voltage transformer. Both cases utilize GOOSE messages for additional communication necessary for the coordination of multiple transformers.

CHAPTER 3

LTC OPERATION SIMULATION

Transformer

For this research, a load tap changing power transformer with 500kV on the high voltage side and 169kV on the low voltage side is assumed. 169kV line-to-line is equivalent to 97.57kV line-to-neutral which will be used for the remaining text. The LTC is located on the high voltage side and allows for 17 tap positions. Position 0 allows the low side voltage to be decreased by 10% to 87.81kV, position 8 yields the same to be the desired 97.57kV and position 16 allows for the voltage to be increased by 10% to 107.33kV. Each tap position therefore represents a voltage change of 1.22kV or 1.25% with respect to 97.57kV.

For the purpose of explaining logic, the LTC model shown in Figure 3.1 will be used. Whenever the LTC operates and the tap is raised from the center position, the number of turns on the high voltage side $N1$ decreases and the turns ratio $N2/N1$ increases. Having $V2=(N2/N1)V1$, raising the tap causes the low side voltage to increase. For example, assume that at center position $N1=1000$ and $N2=500$. If $N1$ is decreased to 950 by raising the tap, $V2=(500/950)(230k/\sqrt{3})=69.89kV$ which is an increase from 66.40kV. Similarly, operating the LTC by lowering the tap causes the low side voltage to decrease.

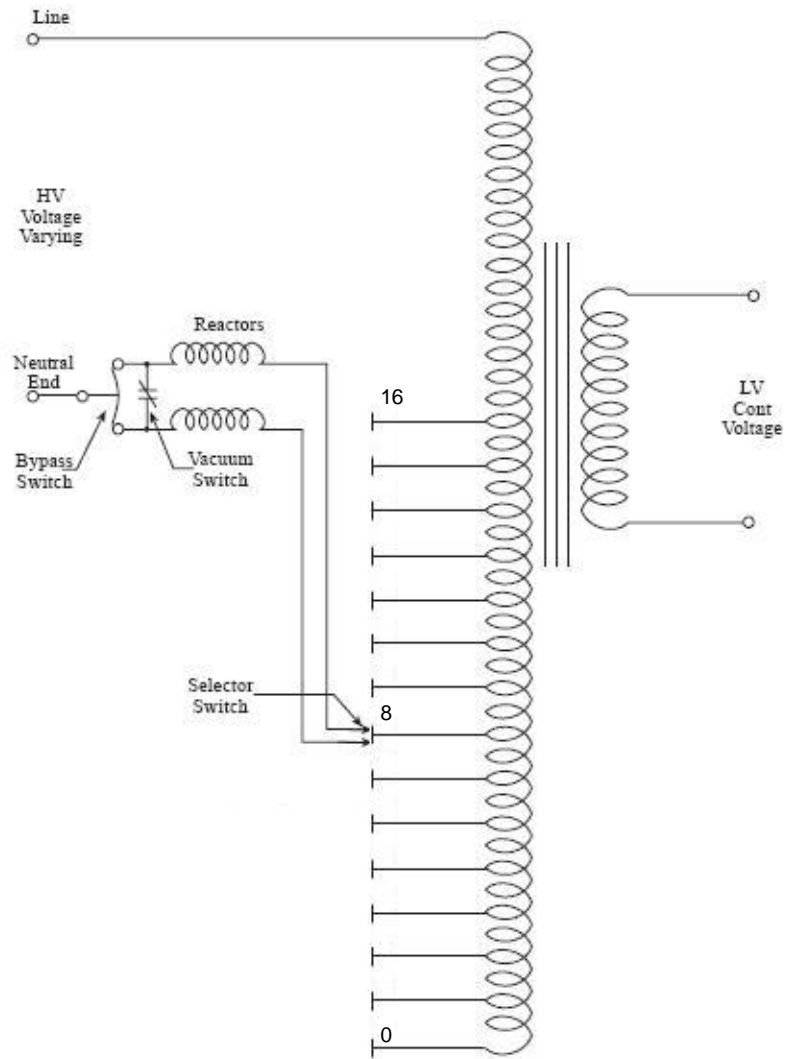

Figure 3.1 LTC model

Overall System

The SEL-2414 Transformer Monitor serves as the control unit and processes the voltage measurements, deciding whether to operate the LTC and when necessary issuing a command to raise or lower the transformer tap. The SEL-2411 Programmable Automation Controller is used to implement both the MU and the AM. In serving as the MU, it receives the voltage values from the test set over copper cable connections and provides these to the control unit

with GOOSE messages. In serving as the AM, it receives a control command from the control unit via GOOSE message and issues an analog signal to the test set via copper cable connection.

Figure 3.2 shows the overall system configuration.

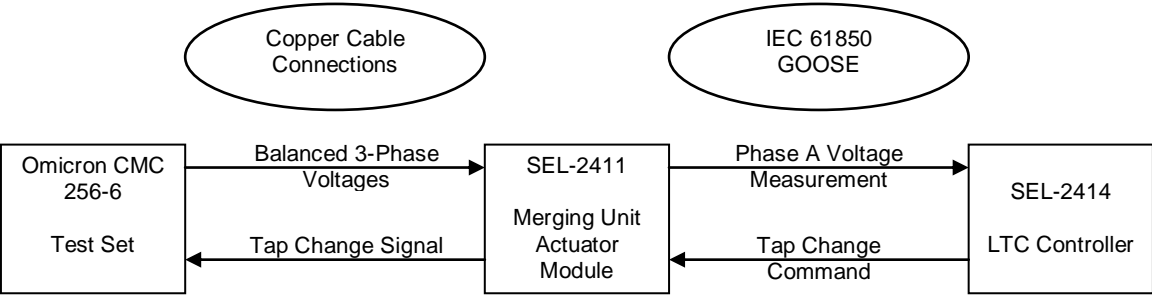

Figure 3.2 Overall System Configuration

Figure 3.3 shows a photograph of the laboratory setup. On the left is the Omicron test set and on the middle right are the SEL-2411 (left on panel) and the SEL-2414 (right on panel). The IED on the top right was not used for this research.



Figure 3.3 Picture of Laboratory Setup

Merging Unit Function

The Omicron CMC 256-6 test set provides a balanced set of 3-phase voltages to the voltage card terminals of SEL-2411 via a switch board and test plug. The voltage magnitude of phase A is then communicated via GOOSE message to SEL-2414.

To set up this communication the AcSELeRator Architect software is used. First, a project is created by downloading the Configured IED Description (CID) file from each device. The CID file contains the substation configuration information necessary for the particular device to accomplish the desired message publishing and message subscribing services. For downloading, the FTP Address, User Name and Password need to be provided. At that time, the device is added to the project. To send the voltage measurement from SEL-2411, a dataset has to be created in Architect by selecting the appropriate IED Data Items and placing them in the dataset. For selecting the voltage magnitude of phase A the path is “Measurand (MX) → Metering (MET) → Logical Node: METMMXU1 → Phase-to-neutral Voltage (PhV) → Phase A (phsA) → Instantaneous Value (instCVal) → Magnitude (mag).” After the dataset has been created, a GOOSE Transmit message is created where, among multiple other settings, the previously created dataset is selected. After successfully sending the modified CID file back to SEL-2411, it begins to publish the specified measurement to the network.

Additional relevant relay settings are that the voltage transformer ratio for SEL-2411 is 1000 and for SEL-2414 is 1.

Processing Function

To have SEL-2414 receive the published measurement, it also is added to the project by downloading its CID file into the Architect software. Under the GOOSE Receive tab, the particular measurement is chosen as the Subscribed Data Item and is mapped to a Remote

Analog Control Input, in this case RA001. After successfully sending the modified CID file back to the 2414, it starts to subscribe to that particular GOOSE message and extracting the voltage measurement.

To execute the LTC control properly, the logic was built using the Graphical Logic feature of the AcSELerator QuickSet software. AcSELerator QuickSet is used for changing relay settings and managing settings files.

Multiple key elements of the control logic used in this research are based on the Application Note “Applying the SEL-2414 Transformer Monitor as a Load Tap Changer Control” published by Schweitzer Engineering Laboratories, Inc. (SEL) [5]. Figure 3.4 on the next page shows the complete logic. The circled parts will be explained separately in the following.

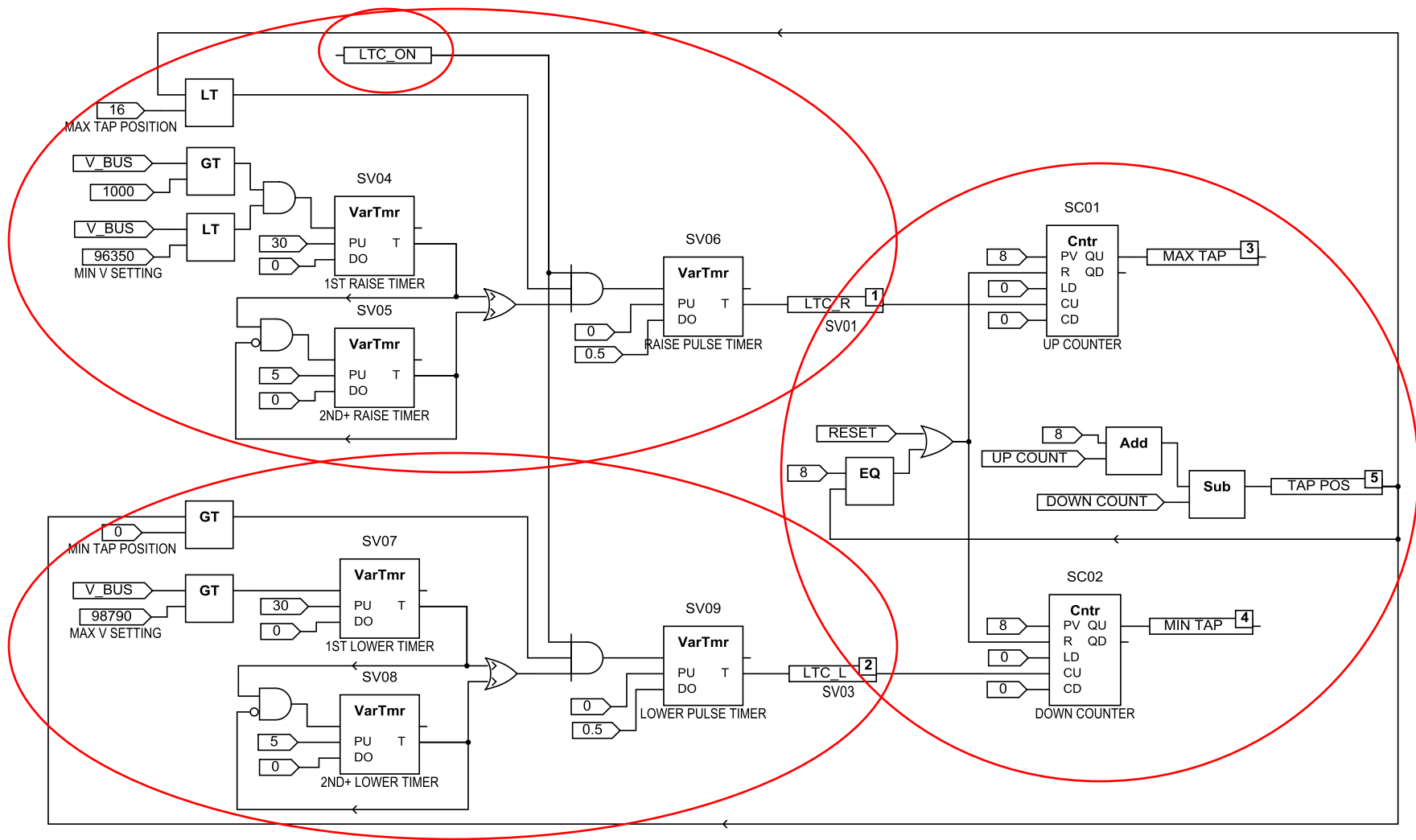

Figure 3.4 Complete LTC Control Logic

Figure 3.5 shows the logic by which LTC control is turned on and off. The input LTC_ON represents the status of latch 1 (device word bit LT01). Latch 1 is set by pressing pushbutton 1 (PB 1) that is located on the front panel. That is, by pressing pushbutton 1 latch 1 status bit asserts and remains high until the latch is reset. Thus, LTC control is turned on. This is indicated by LED 1 on the front panel being on. The latch is programmed to reset by pressing pushbutton 2 (PB 2). That is, by pressing pushbutton 2 latch 1 deasserts and remains low. Thus, LTC control is turned off. At this time, LED 1 is also off.

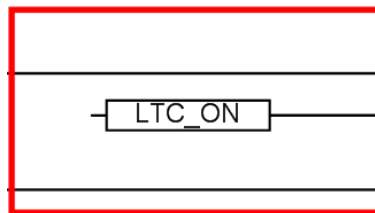

Figure 3.5 LTC Control Turn On/Off Function

Figure 3.6 shows the logic by which the transformer tap is raised.

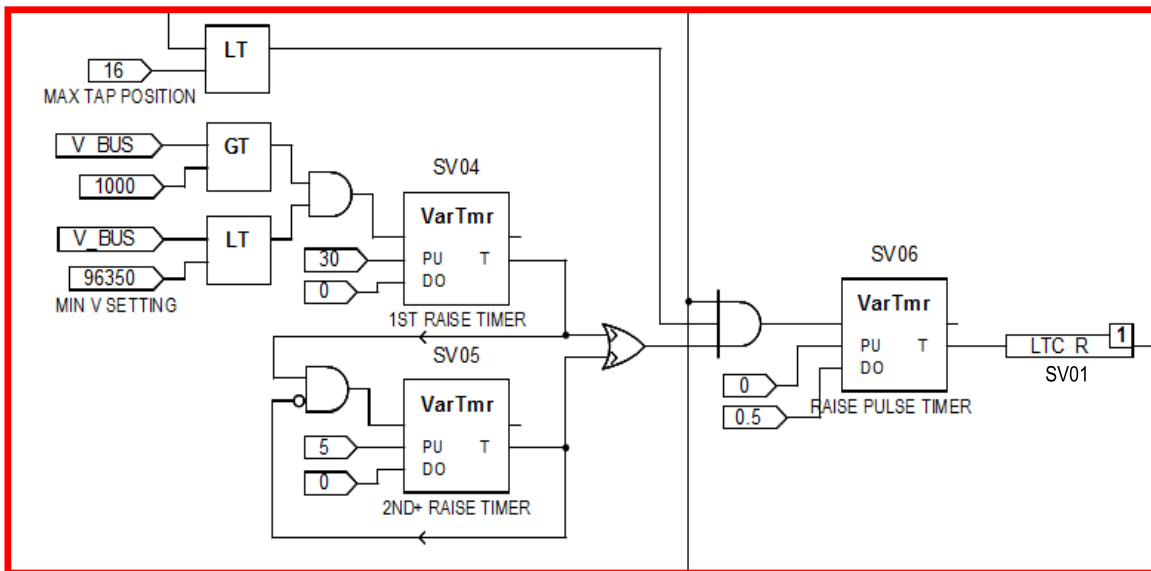

Figure 3.6 Tap-Raise Function

LTC_R represents SELogic Variable 1 (device word bit SV01) which controls that function. When asserted, LTC_R remains high for 0.5 second as determined by the Raise Pulse Timer. With the variable timer (VarTmr), PU is the pickup time and DO is the dropout time which are measured in seconds. The timer has to receive a high input for the duration of the pickup time before the output asserts and after the output has asserted it will maintain a high output for the duration of the dropout time regardless of the state of the input. The Pulse Timer assures that the control signal is long enough for the control action to be initiated.

Three conditions have to be satisfied before LTC_R asserts. One, LTC control has to be on as described above. Two, the tap position has to be less than 16 which is the maximum tap position. How the tap position is determined will be explained later in this section. Three, the bus voltage (V_BUS) has to satisfy two conditions for LTC operation. The first condition is that the bus voltage has to drop below 96.35kV which is equivalent to one tap step below the desired voltage of 97.57kV. This threshold value is chosen for simulation purposes. It is understood that this trigger value is chosen differently in industry. The second condition is that the bus voltage has to remain below 96.35kV for at least 30 seconds as set by the 1st Raise Timer (SV04). Thus, undesired operation due to brief spikes outside of the allowed margin is avoided. The condition that the bus voltage has to be greater than 1kV prevents LTC_R from remaining high whenever the test set is not providing any voltage and the simulated bus voltage is zero. The 2nd+ Raise Timer allows for quicker operation if one tap raise operation is not sufficient to restore the voltage level. After one tap change operation, a pickup time of 5 seconds, instead of 30 seconds, is used for additional tap changes. After the output of this timer asserts, it cuts off the input due to its negated feedback to the AND gate before the timer input, thus restarting the waiting period of 5 seconds if the conditions persist. The fact that the OR gate is triggered by rising edges only allows for a high output to the AND gate at changes of

state only. That way it responds to a new high output from the 2nd+ Raise Timer and prevents a continuous high output due to the 1st Raise Timer.

Figure 3.7 shows the logic by which the transformer tap is lowered. This logic is very similar to the tap raise logic. In this case, LTC_L represents SELogic Variable 3 (device word bit SV03) which controls the tap-lower function. Similarly, this logic has a Lower Pulse Timer, a 1st Lower Timer and a 2nd+ Lower Timer that carry out exactly the same operations. However, two of the three conditions for assertion of LTC_L are different. The other condition, namely for LTC_ON to be true, is the same. One of the two changed conditions is that the tap position has to be greater than 0 which is the minimum tap position. The second changed condition is that the bus voltage has to be greater than 98.79kV which is equivalent to one tap step above the desired voltage of 97.57V.

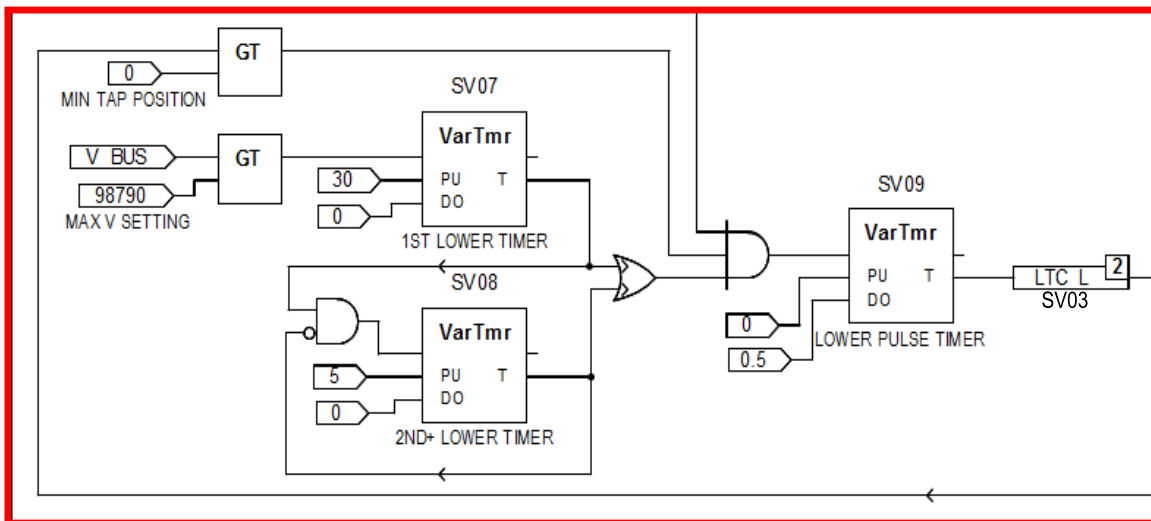

Figure 3.7 Tap-Lower Function

Figure 3.8 shows the logic by which the tap position is calculated. The Up Counter and the Down Counter count the number of tap-raise and tap-lower operations respectively. The count is triggered by a rising edge input. The Preset Value (PV) is set to 8 for both counters which is the maximum count and at which time the output QU asserts to indicate that either the maximum or the minimum tap has been reached. Indicator “MAX TAP” is mapped to LED 2 on the front panel and “MIN TAP” is mapped to LED 3 on the front panel. Both counters can be reset to count zero via pressing pushbutton 3 (PB 3) with is mapped to “RESET”. The tap position number “TAP POS” is calculated using a Math Variable (MV) SELogic Equation with equation $MV01 = 8.00 + SC01 - SC02$ which is equivalent to the equation $TAP POS = 8.00 + UP COUNT - DOWN COUNT$. SC01/UP COUNT and SC02/DOWN COUNT represent the values of the Up Counter and Down Counter respectively.

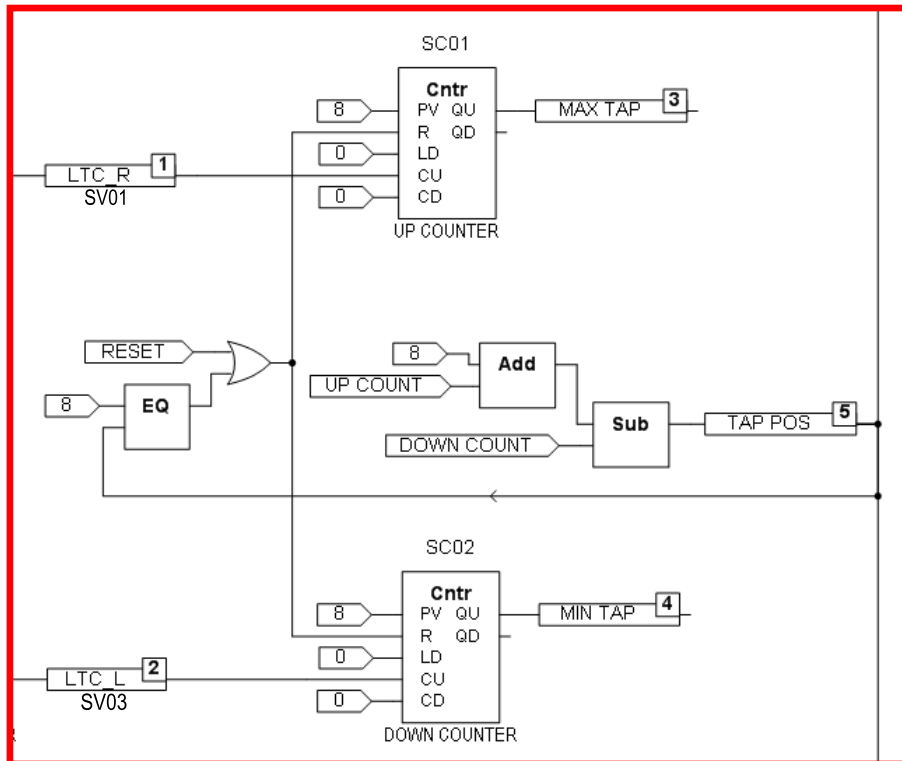

Figure 3.8 Tap Position Calculation Function

The counters also reset whenever the tap position count equals 8. Due to this automatic reset of the counters the number of operations is unlimited and not limited to eight operations.

In the described logic the bus voltage (V_BUS) represents the Remote Analog Control Input RA001 which receives its value from GOOSE messages from SEL-2411 that SEL-2414 subscribes to. The outputs LTC_R and LTC_L are mapped to SELogic Variables 1 and 3 respectively. These are chosen as IED Data Items and placed into a dataset in AcSELERator Architect for SEL-2414. The path is "Status Information (ST) → Annunciation (ANN) → Logical Node for SELogic Variables: SVGGIO3 → Indicator 1/3 (Ind01/Ind03) → Value (stVal)." That dataset is placed in a GOOSE Transmit message. After successfully sending the CID file to SEL-2414, it publishes the states of LTC_R and LTC_L to the network.

Actuator Module Function

SEL-2411 subscribes to the above GOOSE message by mapping the two available Data Items to its Remote Bits (RBs), RB01 and RB03 for LTC_R and LTC_L respectively. These Remote Bits are directly mapped to the output contacts OUT301 and OUT303 of SEL-2411. Whenever the RB goes high, the corresponding output contact energizes and sends a signal to the Omicron test set via copper cable connections over switch board and test plug. After successfully sending the CID file to SEL-2411, it subscribes to the GOOSE message, retrieves the states of LTC_R and LTC_L and maps them to its Remote Bits.

CHAPTER 4

TESTING

Test Setup and Procedure

Using the State Sequencer feature of the Omicron Test Universe software, the test set was configured to supply balanced 3-phase voltages and receive two binary inputs. Binary input 1 received the tap-raise command and binary input 3 received the tap-lower command from SEL-2411.

Two simulations were run, one for raising the tap and one for lowering the tap. In the tap-raise simulation, the voltage was assumed to have dropped to 94.50kV. To get the voltage above the threshold value of 96.35kV, two tap-raise operations are necessary which would yield 96.94kV on the low voltage side. The states shown in Figure 4.1 were created in State Sequencer for this simulation. All main states have the trigger condition to drop out of that state and move to the next one if binary input 1 receives a signal which would be the tap-raise signal. The trigger condition is indicated by the switch symbol at the bottom of the state. The hourglass icon indicates a time-out condition which ends the state if no binary signal is received within the specified time. State 3 and 5, with a duration of 1s, do not have the trigger condition to serve as “breaks” between states that do. If these “breaks” were not in place and all states had the same trigger condition, then once the signal is received for the first time, all subsequent states are skipped at once. Looking at secondary values, state 1 begins with the desired voltage of 97.57V. Then, the voltage drop occurs to yield 94.50V. After the first tap raise the voltage

climbs to 95.72V (states 3 and 4) and after the second to 96.94V (states 5 and 6). The last state has the desired voltage again.

	1	2	3	4	5	6	7
Name	State 1	State 2	State 3	State 4	State 5	State 6	State 7
V A-II	97.57 V	94.50 V	95.72 V	95.72 V	96.94 V	96.94 V	97.57 V
V B-II	97.57 V	94.50 V	95.72 V	95.72 V	96.94 V	96.94 V	97.57 V
V C-II	97.57 V	94.50 V	95.72 V	95.72 V	96.94 V	96.94 V	97.57 V
I A	0.000 A	0.000 A	0.000 A	0.000 A	0.000 A	0.000 A	0.000 A
I B	0.000 A	0.000 A	0.000 A	0.000 A	0.000 A	0.000 A	0.000 A
I C	0.000 A	0.000 A	0.000 A	0.000 A	0.000 A	0.000 A	0.000 A
CMC Rel	0 output(s)	0 output(s)	0 output(s)	0 output(s)	0 output(s)	0 output(s)	0 output(s)
Trigger							

Figure 4.1 State Sequencer States for Tap-Raise Simulation

To test the results, the Time Assessment as shown in Figure 4.2 was set up. All states with trigger condition are listed and set up to record the operating time as soon as the binary input signal is picked up. For state 4, the assessment starts at state 3 because that is when the voltage changes and the timer in the control logic begins. For the measurement conditions named “No Raise” no operation is expected because the voltage is above the operating threshold. For LTC Raise 1 an operating time of 30 seconds is expected which is the setting of the first timer and for LTC Raise 2 an operating time of 5 seconds is expected which is the setting of the second timer.

Time Assessment										
	Name	Ignore before	Start	Stop	Tnom	Tdev-	Tdev+	Tact	Tdev	Assessment
1	No Raise	State 1	State 1	LTC Raise 0>1	0.000 s	0.000 s	0.000 s			
2	LTC Raise 1	State 2	State 2	LTC Raise 0>1	30.00 s	1.000 s	1.000 s			
3	LTC Raise 2	State 3	State 3	LTC Raise 0>1	5.000 s	1.000 s	1.000 s			
4	No Raise	State 6	State 6	LTC Raise 0>1	0.000 s	0.000 s	0.000 s			
5	No Raise	State 7	State 7	LTC Raise 0>1	0.000 s	0.000 s	0.000 s			

Figure 4.2 Tap-Raise Simulation Time Assessment

The tap-lower simulation was set up very similarly to the tap-raise simulation. The only difference is that three instead of two tap change operations are required. However, the same format applies. Here, the threshold voltage for the controller to initiate a tap-lower operation is 98.79kV. Figure 4.3 shows the states used in State Sequencer. Following, Figure 4.4 shows the measurement conditions for time assessment. As before the expected operating time for LTC Lower 1 is 30 seconds and 5 seconds for both LTC Lower 2 and LTC Lower 3.

Table View: LTC_Lower.seq

	1	2	3	4	5	6	7	8	9
Name	State 1	State 2	State 3	State 4	State 5	State 6	State 7	State 8	State 9
V A-N	97.57 V	102.0 V	100.8 V	100.8 V	99.56 V	99.56 V	98.34 V	98.34 V	97.57 V
V B-N	97.57 V	102.0 V	100.8 V	100.8 V	99.56 V	99.56 V	98.34 V	98.34 V	97.57 V
V C-N	97.57 V	102.0 V	100.8 V	100.8 V	99.56 V	99.56 V	98.34 V	98.34 V	97.57 V
I A	0.000 A	0.000 A	0.000 A	0.000 A	0.000 A	0.000 A	0.000 A	0.000 A	0.000 A
I B	0.000 A	0.000 A	0.000 A	0.000 A	0.000 A	0.000 A	0.000 A	0.000 A	0.000 A
I C	0.000 A	0.000 A	0.000 A	0.000 A	0.000 A	0.000 A	0.000 A	0.000 A	0.000 A
CMC Rel	0 output(s)	0 output(s)	0 output(s)	0 output(s)	0 output(s)	0 output(s)	0 output(s)	0 output(s)	0 output(s)
Trigger									

Figure 4.3 State Sequencer States for Tap-Lower Simulation

Measurement View: LTC_Lower.seq

Time Assessment										
	Name	Ignore before	Start	Stop	Tnom	Tdev-	Tdev+	Tact	Tdev	Assessment
1	No Raise	State 1	State 1	LTC Lower 0>1	0.000 s	0.000 s	0.000 s			
2	LTC Lower 1	State 2	State 2	LTC Lower 0>1	30.00 s	1.000 s	1.000 s			
3	LTC Lower 2	State 3	State 3	LTC Lower 0>1	5.000 s	1.000 s	1.000 s			
4	LTC Lower 3	State 5	State 5	LTC Lower 0>1	5.000 s	1.000 s	1.000 s			
5	No Raise	State 8	State 8	LTC Lower 0>1	0.000 s	0.000 s	0.000 s			
6	No Raise	State 9	State 9	LTC Lower 0>1	0.000 s	0.000 s	0.000 s			

Figure 4.4 Tap-Lower Simulation Time Assessment

Test Results

For a particular tap-raise simulation the results are shown in the following figure, Figure 4.5.

Measurement View: LTC_Raise.seq										
Time Assessment										
	Name	Ignore before	Start	Stop	Tnom	Tdev-	Tdev+	Tact	Tdev	Assessment
1	No Raise	State 1	State 1	LTC Raise 0>1	0.000 s	0.000 s	0.000 s	34.37 s	34.37 s	✗
2	LTC Raise 1	State 2	State 2	LTC Raise 0>1	30.00 s	1.000 s	1.000 s	31.37 s	1.370 s	✗
3	LTC Raise 2	State 3	State 3	LTC Raise 0>1	5.000 s	1.000 s	1.000 s	5.002 s	1.500 ms	+
4	No Raise	State 6	State 6	LTC Raise 0>1	0.000 s	0.000 s	0.000 s			✗
5	No Raise	State 7	State 7	LTC Raise 0>1	0.000 s	0.000 s	0.000 s			✗

Figure 4.5 Tap-Raise Simulation Results

As expected, the first tap-raise signal does not occur until time 34.37 seconds. This time includes the duration of state 1, the 30 seconds from the 1st Raise Timer delay and an additional 1.37 seconds for multiple processing delays. Measuring from the beginning of state 2, the operating time of the first tap raise is 31.37 seconds, again with processing delays of a total of 1.37 seconds. Because LTC control is not time critical, these delays will not be discussed in further detail. The assessment of LTC Raise 1 is marked with the “X” as having failed because the operation occurred outside of the specified time deviation of +/- 1 second. The second tap raise occurs 5.002 seconds later and the assessment is marked with a “+” for having passed. The explanation for the significantly quicker second tap-raise operation is that before the initiation of the second tap raise, the voltage is already below the threshold setting and the output of the 1st Raise Timer is already high. Therefore, one can conclude that the majority of the delay in the first tap-raise operation is due to the measuring and communicating of the voltage value before it is available for the logic. An additional factor is the time it takes for the test set to switch between states and therefore restart the time measurement. Given that all

measurements in Figure 4.5 are set up to stop when the binary input LTC Raise asserts, one can see that there is no operation in states 6 and 7 because no operating time is recorded.

After running five simulations the results are shown in Table 4.1. The units are seconds and *Tnom*, *Tact* and *Tdev* stand for the nominal, actual and deviated operating time respectively.

Table 4.1 Summary of Tap-Raise Simulation Results

Simulation	LTC Raise 1			LTC Raise 2		
	Tnom	Tact	Tdev	Tnom	Tact	Tdev
1	30	31.37	1.37	5	5.002	0.0015
2	30	31.13	1.132	5	5.001	0.0013
3	30	32.16	2.163	5	5.002	0.0015
4	30	32.23	2.232	5	5.002	0.0015
5	30	31.19	1.193	5	5.002	0.0016
Average	30	31.62	1.62	5	5.002	0.0015

For a particular tap-lower operation the results are shown in Figure 4.6.

Measurement View: LTC_Lower.seq

Time Assessment										
	Name	Ignore before	Start	Stop	Tnom	Tdev-	Tdev+	Tact	Tdev	Assessment
1	No Raise	State 1	State 1	LTC Lower 0>1	0.000 s	0.000 s	0.000 s	34.25 s	34.25 s	✗
2	LTC Lower 1	State 2	State 2	LTC Lower 0>1	30.00 s	1.000 s	1.000 s	31.25 s	1.254 s	✗
3	LTC Lower 2	State 3	State 3	LTC Lower 0>1	5.000 s	1.000 s	1.000 s	5.002 s	1.500 ms	+
4	LTC Lower 3	State 5	State 5	LTC Lower 0>1	5.000 s	1.000 s	1.000 s	5.010 s	10.00 ms	+
5	No Raise	State 8	State 8	LTC Lower 0>1	0.000 s	0.000 s	0.000 s			✗
6	No Raise	State 9	State 9	LTC Lower 0>1	0.000 s	0.000 s	0.000 s			✗

Figure 4.6 Tap-Lower Simulation Results

These results are consistent with the ones from the tap-raise simulation and can be explained similarly. Again, there is no operation in states 1, 6 and 7. The first tap-lower operation occurs after 31.25 seconds with a delay of 1.254 seconds, the second operation occurs after 5.002 seconds with a delay of 0.0015 second and the third after 5.01 seconds with a delay of 0.01 second. All operations happen as expected, only with a significant delay for the first operation.

The results of five simulations are summarized in Table 4.2.

Table 4.2 Summary of Tap-Lower Simulation Results (seconds)

Simulation	LTC Lower 1			LTC Lower 2			LTC Lower 3		
	Tnom	Tact	Tdev	Tnom	Tact	Tdev	Tnom	Tact	Tdev
1	30	31.25	1.254	5	5.002	0.0015	5	5.01	0.01
2	30	31.76	1.76	5	5.001	0.0014	5	5.01	0.01
3	30	31.28	1.282	5	5.001	0.0013	5	5.01	0.01
4	30	31.48	1.476	5	5.002	0.0017	5	5.01	0.01
5	30	31.29	1.286	5	5.001	0.0012	5	5.01	0.01
Average	30	31.41	1.412	5	5.0014	0.0014	5	5.01	0.01

Another quantity of interest is the tap position count. The tap position count is mapped to Math Variable 1 (MV01) in SEL-2414. Also, pushbutton 3 (PB 3) on the front panel is programmed to reset the counters such that the tap position is 8. After the tap-raise simulation the tap position count is 10 due to two tap-raise operations. Starting from 8, after the tap-lower simulation the tap position count is 5 due to 3 tap-lower operations. It has been tested and verified that the tap position count does not go beyond its limits of 0 and 16, that the two LEDs

on the front panel do indicate that either the upper or lower limit has been reached and that the LTC does not operate once those limits have been reached.

CHAPTER 5

DISCUSSION

Evaluation of Test Results

For the application of LTC control the results of this research are satisfactory. Because fast operation is not essential the observed operation delays are acceptable. However, as IEC 61850 is more widely implemented, intermediate devices are likely to be simpler than the devices used for this research which would result in reduced processing delays. The impact of the additional traffic on the network is insignificant. Especially the use of the Dead Band feature in AcSELerator Architect software promises to eliminate the majority of the network traffic of the current configuration by setting a dead band for the voltage measurement such that no GOOSE messages for continuously updating voltage levels will be sent whenever the voltage is within acceptable limits. However, it was not possible to test the Dead Band feature at the time of this writing. There is also the option of using Virtual Local Area Networks (LANs) to segment the network such that overall traffic volume is reduced. More important than fast operation is the reliability of operation. During the testing for this research the proposed scheme has operated reliably, that is it always operated correctly and never operated incorrectly. A discussion on reliability follows in the next section.

Reliability

In the field of power systems reliability is defined as a combination of dependability and security. IEEE standard C37.100-1992 defines dependability as “The facet of reliability that

relates to the degree of certainty that a relay or relay system will operate correctly.” Security is defined as “That facet of reliability that relates to the degree of certainty that a relay or relay system will not operate incorrectly.” [6]

There are multiple ways that reliability is or can be achieved for LTC control. For LTC control in general, redundancy is frequently in place today as LTC can be operated in multiple ways as described earlier in the text. Again, the four options are one, a dedicated device (VRR); two, the operator via SCADA; three, a multifunctional device; four, manual operation at the transformer. It is common to have the options for operator operation, manual operation and one of the other two options in place together. Therefore, reliability is enhanced.

For the proposed LTC control the vulnerabilities are one, failure of the Instrument Voltage Transformer (VT); two, failure of the network connection from the devices; three, failure of the control unit itself. To compensate the failure of a VT, the control unit can be programmed to access measurements from another device connected to another VT if another VT exists and if the measurements are available on the network. In the case of a centralized substation computer, only one VT is needed for operation, but additional VTs for redundancy would be available. The failure of the network connection can be caused by the failure of the device’s communication port, the Ethernet cable or the switch. To prevent disability of the system in case of the failure of Ethernet cable or switch it is commonly suggested to have a redundant switch and all devices have two connections leading to two different switches. The same can compensate for failure of the communication port of a device. If two connections are available, upon detection of the port failure, the device can switch communications from its primary to its secondary port. [7] To compensate for the failure of the control unit, LTC control can be implemented in multiple IEDs for redundancy. In general it is recommended to use different devices and different schemes for the redundant system to avoid common mode failures. [6]

Another generally approved practice is to physically separate redundant systems if possible to avoid destruction by such occurrences as fire. [7] In the case of a centralized substation computer that services all applications, its failure is not acceptable and a thorough investigation of contingencies must be addressed to ensure reliable operation of the system. In all cases, the only component that cannot be redundant is the physical tap change mechanism inside the transformer.

Overall, for LTC control it is not imperative to implement great measures for reliability. Still, the more reliably LTC control functions the better especially when the power system operates close to its limits as is the case more and more often today. The power system operating close to its limits may also call for a more sensitive setting of the voltage threshold that triggers operation in the logic to guard stability of the voltage level and the system. In each case, importance of reliable operation of LTC control has to be weighed against its cost.

Advantages of Proposed LTC Control

The major advantage of the proposed LTC control solution is that it can be implemented using GOOSE messaging which is becoming more and more widely available for protection and automation devices in the power industry. By relying on networked communication versus copper cable connection, it is very flexible and can be implemented on different multifunctional IEDs.

CHAPTER 6

CONCLUSIONS

It was the goal of this research to achieve full implementation of IEC 61850 in LTC control. This goal has been accomplished as can be seen in Figure 6.1. It shows the two devices used for this research and their connections. Notice that the control unit SEL-2414 (on the left) has an Ethernet connection only. Functioning as the MU and as the AM, SEL-2411 (one the right) has copper cable connections to receive voltages and send tap change signals to the tap change motor. It also has an Ethernet connection for communicating with SEL-2414.

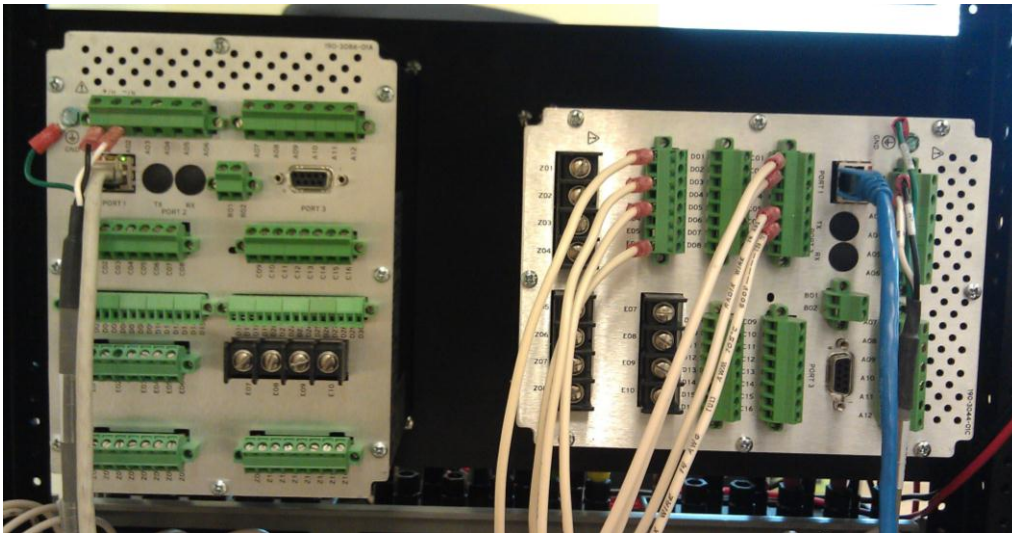

Figure 6.1 Picture of Used Devices

The next step in this research could be to use Sampled Values messaging to communicate voltage measurements to the control unit as well as to advance the control logic to

accommodate more realistic operating conditions such as triggering LTC operation according to predicted load flow or blocking of LTC control during fault or other abnormal conditions.

Additional improvements can be one, implementation of narrow-band and wide-band margin for the operating voltage so that if too many operations occur on the narrow-band setting, operation could be switched to the wide-band setting; two, using the positive-sequence voltage for the operating voltage in the logic to improve reliability in the case that the voltage of the three phases is not sufficiently well balanced (the positive-sequence voltage was not available in the devices used for this research).

Still, IEC 61850 is in the beginning stages of being widely used in the power industry today. One of the major obstacles to that progress is the necessity to educate and train employees such that they would be able to competently operate and troubleshoot an IEC 61850-based system.

REFERENCES

- [1] Blackburn, Lewis, and Thomas Domin, Protective Relaying: Principles and Applications, New York: CRC Press, 2007.
- [2] Apostolov, Alexander, "IEC 61850 Technical Seminar: Fundamentals, Applications and Benefits," The University of Tennessee at Chattanooga, 2010.
- [3] Gajic, Z.; Aganovic, S.; Benovic, J.; Leci, G.; Gazzari, S.; , "Using IEC 61850 analogue goose messages for OLTC control of parallel transformers," *Developments in Power System Protection (DPSP 2010). Managing the Change, 10th IET International Conference on* , vol., no., pp.1-5, March 29 2010-April 1 2010
doi: 10.1049/cp.2010.0227
- [4] Ye Li; Nair, N.C.; Sing-Kiong Nguang; , "Improved coordinated control of On-load Tap Changers," *Universities Power Engineering Conference (AUPEC), 2010 20th Australasian* , vol., no., pp.1-6, 5-8 Dec. 2010
- [5] Wright, Larry, "Applying the SEL-2414 Transformer Monitor as a Load Tap Changer Control," Schweitzer Engineering Laboratories 2011, Pullman, Washington.
- [6] Sykes, J.; Madani, V.; Burger, J.; Adamiak, M.; Premerlani, W.; , "Reliability of protection systems (what are the real concerns)," *Protective Relay Engineers, 2010 63rd Annual Conference for* , vol., no., pp.1-16, March 29 2010-April 1 2010
doi: 10.1109/CPRE.2010.5469482
- [7] Ward, S.; Gwyn, B.; Antonova, G.; Apostolov, A.; Austin, T.; Beaumont, P.; Beresh, B.; Bradt, D.; Brunello, G.; Dac-Phuoc Bui; Carden, M.; Cunico, R.; Deronja, A.; Elmore, W.; Garcia, R.; Haas, B.; Hanbali, A.; Harris, R.; Heavey, P.; Henneberg, G.; Huntley, C.; Johnson, G.; Sungsoo Kim; Kobet, G.; Long, J.; Martin, A.; McClure, C.; McElray, J.; Mendik, M.; Moskos, G.; Mozina, C.; Niemira, J.; O'Brien, J.; Saia, N.; Sambasivan, S.; Saygin, S.; Seegers, T.; Sevcik, D.; Simon, M.; Soehren, J.; Stuart, B.; Sykes, J.; Tholomier, D.; Turner, S.; Uchiyama, J.; Wang, J.; Ware, D.; Wiedman, T.; Young, R.; Zipp, J.; Udren, E.; , "Redundancy considerations for protective relaying systems," *Protective Relay Engineers, 2010 63rd Annual Conference for* , vol., no., pp.1-10, March 29 2010-April 1 2010
doi: 10.1109/CPRE.2010.5469478

VITA

Nelli Sichwart was born in Shymkent, Kazakhstan, to the parents of Andreas and Lilli Sichwart. She is the older of two children with a younger brother, Alex. Their family immigrated to Germany when she was seven years old. Nelli completed elementary school at the Kettlerschule in Hamm, Germany and went on to attend the Beisenkamp Gymnasium. After having visited Chattanooga, TN, couple of times during high school she applied and was accepted to attend The University of Tennessee at Chattanooga. Nelli graduated Summa Cum Laude with a Bachelor of Science in Electrical Engineering in May 2010. She was offered a graduate research assistantship under the Department of Energy grant for Workforce Training for the Electric Power Sector, and continued to pursue the Master of Science in Electrical Engineering. During that time she was awarded 2012 Outstanding Master's Student in Engineering.