

Improved Torque Control Performance of Direct Torque Control for 5-Phase Induction Machine

Logan Raj Lourdes Victor Raj¹, Auzani Jidin², Kasrul Abdul Karim³, Tole Sutikno⁴, R. Sundram⁵, Mohd Hatta Jopri⁶

^{1,2,3,5,6}Department of Power Electronics and Drives, Universiti Teknikal Malaysia Melaka (UTeM), Malaysia

⁴Department of Electrical Engineering, Universitas Ahmad Dahlan (UAD), Indonesia

Article Info

Article history:

Received Jul 27, 2013

Revised Oct 10, 2013

Accepted Oct 23, 2013

Keyword:

Direct torque control

Five-phase induction machine

Look-up tables

Motor drive

Optimal switching strategy

ABSTRACT

In this paper, the control of five-phase induction machine using Direct Torque Control (DTC) is presented. The general D-Q model of five-phase induction machine is discussed. The de-coupled control of stator flux and electromagnetic torque based on hysteresis controller similar to conventional DTC is applied to maintain the simplicity of the system. Three sets of look-up tables consist of voltage vectors with different amplitude that selects the most optimal voltage vectors according motor operation condition is proposed. This provides excellent torque dynamic control, reduces torque ripple, lower switching frequency (high efficiency) and extension of constant torque. Simulation results validate the improvement achieved.

Copyright © 2013 Institute of Advanced Engineering and Science.
All rights reserved.

Corresponding Author:

Logan Raj Lourdes Victor Raj,
Departement of Electrical Engineering,
Universiti Teknikal Malaysia Melaka (UTeM),
76100 Durian Tunggal, Malacca, Malaysia.
Email: logan0688@student.utm.edu.my

1. INTRODUCTION

The popularity of induction machine has been on the rise and became the major driving factors in the development of high performance control strategy. Although there are many proposed control strategies available, Field Oriented Control (FOC) and Direct Torque Control (DTC) are the most researched [1,2]. The objective of both of the control strategies are similar although their operation principal are different. Their objectives are to precisely control the torque and flux of rotary machine regardless of load condition and other external disturbance. F. Blaschke proposed the Field Oriented Control (FOC) [3]. This control strategy imitates the control method of separately excited dc motor where the stator current is decomposed into flux and torque component through the means of coordinate transformation and rotor flux orientation [3, 4,5]. In DTC, the flux and torque of the rotating machine are controlled directly. This method functions based on space vector theory where by selecting the optimal space vector in each sampling period, the stator flux and torque are controlled effectively [6, 7, 8].

The multiphase was originated in the late 1960's. Multiphase drives are developed in order to overcome the problem in three phase six-step inverter fed machines which are low frequency torque ripple [9,10]. Multiphase induction drive possesses many advantages compared to the conventional three-phase drive. Those advantages are reduced amplitude and increased frequency of torque pulsation, reduced rotor harmonic current, reduced current per phase without increase in voltage per phase and lower dc link current harmonics with increased reliability [7,9,10]. Fig. 1 illustrates the 5-phase VSI connected to the star windings of 5-phase induction machine. In each inverter leg, the power switches are represented with the upper and lower switches which are complementary to each other. The switching state of an inverter leg indicates 1

when the upper switch of the inverter leg is ON and the lower switch is OFF, and vice-versa. The switching state corresponds to $[S_a S_b S_c S_d S_e]$. The combination of switching states can produce 30 non-zero active voltage switching space vectors together with 2 zero space vectors which is illustrated in Fig. 2 together with the voltage modes. In general terms of switching states, the phase voltage space vectors of the 5-phase is given as follow:

$$v_k = \frac{2}{5} V_{DC}(S_a + a S_b + a^2 S_c + a^{-2} S_d + a^{-1} S_e) \tag{1}$$

where $a = e^{j2\pi/5}$ and $k=0, 1, 2, \dots, 31$.

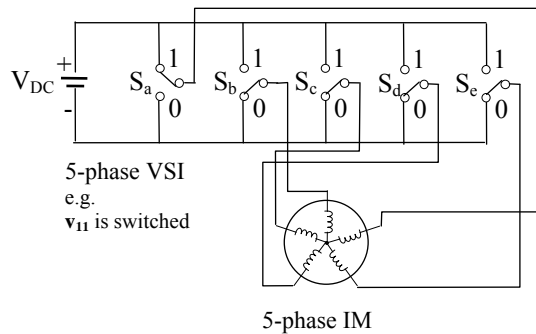

Figure 1. 5-phase VSI connected to 5-phase induction motor.

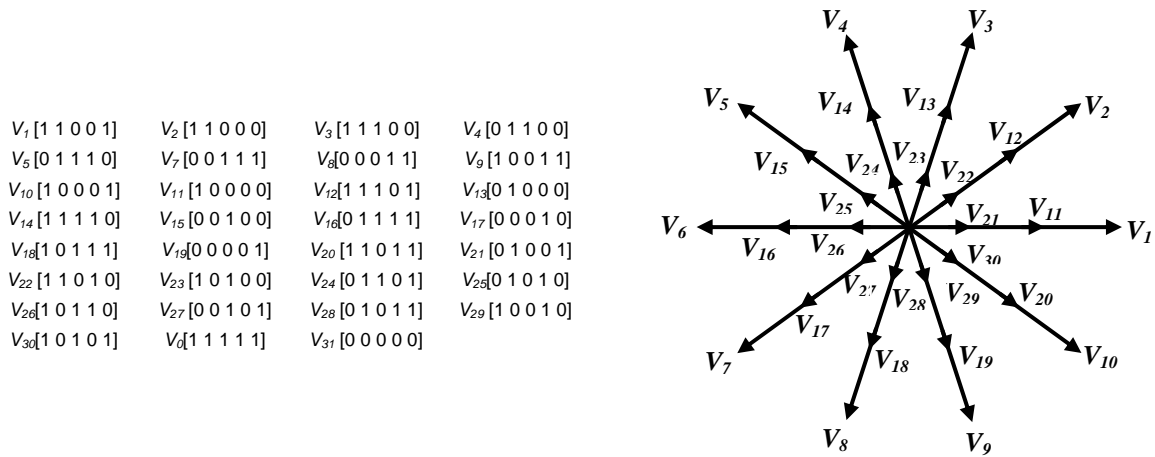

Figure 2. Space voltage vectors available in 5-phase VSI

In this paper, the DTC method is implemented for the five-phase induction machine. It can be shown that the greater number of switching states provided in five-phase DTC system can give more degrees of freedom to select the most optimal voltage vector to improve further DTC performances. The mathematical model of five phase machine is given. Other than that, a detailed explanation regarding the impact of voltage vector selection in influencing the dynamic torque performance, extension of constant torque region, minimization in torque ripple and switching frequency are also given.

2. GENERALISED D-Q MODEL OF FIVE PHASE INDUCTION MACHINE

The D-Q Model of Five Phase Induction Machine is almost similar to the conventional three phase machine. The difference between them are there will be five new stator (current, voltage, and stator flux) with spatial displacement between any two consecutive stator phases equals $\alpha = 2\pi/5$ for the five phase machine. Assuming that the windings are connected in star with single neutral point, zero sequence component does not exist in five phase machine. The x-y component of the machine can also be neglected due to the sinusoidal distribution of the flux around the air gap. Assuming that the machine equation are transformed into an arbitrary frame of reference rotating at angular speed ω_e , the model of n-phase (five) machine with sinusoidal winding distribution can be given as follow:

Stator circuit equations:

$$V_{ds} = R_s i_{ds} + \frac{d}{dt} \varphi_{ds} - \omega_e \varphi_{qs} \quad (2)$$

$$V_{qs} = R_s i_{qs} + \frac{d}{dt} \varphi_{qs} - \omega_e \varphi_{ds} \quad (3)$$

Rotor circuit equations:

$$V_{dr} = R_r i_{dr} + \frac{d}{dt} \varphi_{dr} - (\omega_e - \omega_r) \varphi_{qr} \quad (4)$$

$$V_{qr} = R_r i_{qr} + \frac{d}{dt} \varphi_{qr} - (\omega_e - \omega_r) \varphi_{dr} \quad (5)$$

Flux linkage expression in terms of current:

$$\varphi_{ds} = L_{ls} i_{ds} + L_m (i_{ds} + i_{dr}) \quad (6)$$

$$\varphi_{dr} = L_{lr} i_{dr} + L_m (i_{ds} + i_{dr}) \quad (7)$$

$$\varphi_{qs} = L_{ls} i_{qs} + L_m (i_{qs} + i_{qr}) \quad (8)$$

$$\varphi_{qr} = L_{lr} i_{qr} + L_m (i_{qs} + i_{qr}) \quad (9)$$

$$\varphi_{dm} = L_m (i_{ds} + i_{dr}) \quad (10)$$

$$\varphi_{qm} = L_m (i_{qs} + i_{qr}) \quad (11)$$

$$i_{ds} = \frac{\varphi_{ds}(L_{lr} + L_m) - L_m \varphi_{dr}}{(L_{ls} + L_m)(L_{lr} + L_m) - L_m^2} \quad (12)$$

$$i_{qs} = \frac{\varphi_{qs}(L_{lr} + L_m) - L_m \varphi_{qr}}{(L_{ls} + L_m)(L_{lr} + L_m) - L_m^2} \quad (13)$$

$$i_{dr} = \frac{\varphi_{dr}(L_{lr} + L_m) - L_m \varphi_{ds}}{(L_{ls} + L_m)(L_{lr} + L_m) - L_m^2} \quad (14)$$

$$i_{qr} = \frac{\varphi_{qr}(L_{lr} + L_m) - L_m \varphi_{qs}}{(L_{ls} + L_m)(L_{lr} + L_m) - L_m^2} \quad (15)$$

Torque equation:

$$T_e = PL_m (i_{qs} i_{qr} - i_{ds} i_{dr}) \quad (16)$$

Speed equation:

$$\omega_r = \int \frac{P}{2J} (T_e - T_L) dt \quad (17)$$

where L_s , L_r and L_m are the total leakage factor, J is inertia, P is the number of pole pairs and ω_r is the rotor electric angular speed in rad/s.

3. OPTIMAL DTC SWITCHING STRATEGY

This section discusses the optimal selection of voltage vectors to achieve high-performance DTC for 5-phase induction machine. Since the 5-phase VSI provides more number of switching vectors, it is therefore give more options to select the most optimal voltage vector for every operating condition.

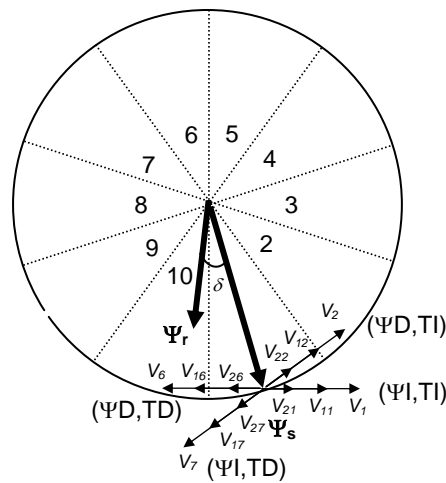

Figure 3. Selection of voltage vectors for controlling stator flux in Sector 1.

By applying 5-phase VSI, the trajectory of flux vector in stator flux plane can be mapped into 10 sectors which are equally divided by 36° , as illustrated in Fig. 3. Figure 3 also shows possible voltage vectors to be selected whenever the flux lies within a Sector 1, in controlling both flux and torque. It should be noted that; the control of flux vector is directly affected by the applied voltage vector (both with same direction), while the control of torque is mainly determined by the load angle (δ). Assuming the trajectory of flux vector forming a circular locus in counter-clockwise direction. To increase both flux and torque ($\Psi I, T I$), voltage vectors v_{21} , v_{11} and v_1 are chosen. If the torque is maintained to increase, on the other hand the flux needs to be decreased ($\Psi D, T I$), voltage vectors v_{22} , v_{12} and v_2 are chosen. The voltage vector v_1 has the longest amplitude which gives the most significant impact on flux and torque increase followed by v_{11} (medium amplitude) and v_{21} (shortest amplitude). In another case, the voltage vector v_2 has the longest amplitude which gives the most significant impact on flux decrease and torque increase, followed by v_{12} (medium amplitude) and v_{22} (shortest amplitude). Among of three possible voltage vectors stated in both cases, there is only one voltage vector that could be the most optimal vector to be chosen to improve DTC performances. In order to identify the most optimal vector, it is desirable to study the effects of torque slope due to the application voltage vectors for different operating conditions. The rate of change of torque can be controlled by applying the most optimal vector (either the one that has the longest amplitude, or medium amplitude, or shortest amplitude) according to the operating conditions, so that it can improve the switching frequency, torque ripple, torque regulation and torque dynamic control. Taking into account that the torque variation (or slope) is affected by the applied voltage vector as well as operating conditions which was reported in [11]. The torque slope equation can be used to analyze the effects of voltage vector application and operating conditions as given in (18).

$$\frac{T_{e,n+1} - T_{e,n}}{\Delta t} = -T_{e,n} \left(\frac{1}{\sigma\tau_s} + \frac{1}{\sigma\tau_r} \right) + \frac{3}{2} P \frac{L_m}{\sigma L_s L_r} [(v_{s,n} - j\omega_r \Psi_{s,n}) \cdot j \Psi_{r,n}] \quad (18)$$

where P is the number of pole pairs, ω_r is the rotor electric angular speed in rad./s, L_s , L_r and L_m are the σ is the total leakage factor, τ_s and τ_r are the time constant, and Ψ_r is the rotor flux.

Equation (18) indicates that the torque slope depends on the rotor speed and applied voltage vector, whereby the rest of parameters can be assumed to have constant values. According to (18), the torque increases rapidly at low speed operations, thus an active voltage vector that has the smallest amplitude needs to be chosen in order to slower down the rate of increase. Hence, it can minimize the switching frequency as well as switching losses. Furthermore, it can prevent reversed voltage vectors to be selected whenever the output torque exceeds beyond the hysteresis band, especially in digital implementation, which causes extreme torque slope and consequently produces a larger torque ripple [12]. In the case of high speed operations, voltage vectors that have the longest amplitude should be chosen. This selection naturally enhances the output voltage to meet higher demand in controlling torque at high speed operations [13,14]. By applying the longest amplitude of voltage vector, it also can improve dynamic control performance for entire speed range of operations.

In this paper, three different look-up tables were introduced where each of the look up table represents a group of selection of voltage vectors, as tabulated in Table 1. The first look-up table represents the longest amplitude (Table 1(a)), second look-up table represents medium amplitude (Table 1(b)) and the third look-up table represents the shortest amplitude (Table 1(c)). Each set of voltage vector possesses a certain criteria according to the desired improvements and speed operating conditions, as discussed above.

Table 1. Selection of Voltage Vector for (a) Longest- (b) Medium- and (c) Smallest Amplitude

| Flux error status | | Torque error status | | Sector | | | | | | | | | | |
|----------------------------|---|---------------------|--|--------|-----|-----|-----|-----|-----|-----|-----|-----|-----|----|
| S_Ψ | | S_T | | 1 | 2 | 3 | 4 | 5 | 6 | 7 | 8 | 9 | 10 | |
| (a) | 1 | 1 | | V1 | V2 | V3 | V4 | V5 | V6 | V7 | V8 | V9 | V10 | |
| | | 0 | | V31 | V0 | V31 | V0 | V31 | V0 | V31 | V0 | V31 | V0 | |
| | | -1 | | V7 | V8 | V9 | V0 | V1 | V2 | V3 | V4 | V5 | V6 | |
| | 0 | 1 | | V2 | V3 | V4 | V5 | V6 | V7 | V8 | V9 | V10 | V1 | |
| | | 0 | | V0 | V31 | V0 | V31 | V0 | V31 | V0 | V31 | V0 | V31 | V0 |
| | | -1 | | V6 | V7 | V8 | V9 | V10 | V1 | V2 | V3 | V4 | V5 | |
| Flux error status S_Ψ | | Torque error status | | Sector | | | | | | | | | | |
| | | S_T | | 1 | 2 | 3 | 4 | 5 | 6 | 7 | 8 | 9 | 10 | |
| (b) | 1 | 1 | | V11 | V12 | V13 | V14 | V15 | V16 | V17 | V18 | V19 | V20 | |
| | | 0 | | V0 | V31 | V0 | V31 | V0 | V31 | V0 | V31 | V0 | V31 | |
| | | -1 | | V17 | V18 | V19 | V20 | V11 | V12 | V13 | V14 | V15 | V16 | |
| | 0 | 1 | | V12 | V13 | V14 | V15 | V16 | V17 | V18 | V19 | V20 | V11 | |
| | | 0 | | V31 | V0 | V31 | V0 | V31 | V0 | V31 | V0 | V31 | V0 | |
| | | -1 | | V16 | V17 | V18 | V19 | V20 | V11 | V12 | V13 | V14 | V15 | |
| Flux error status S_Ψ | | Torque error status | | Sector | | | | | | | | | | |
| | | S_T | | 1 | 2 | 3 | 4 | 5 | 6 | 7 | 8 | 9 | 10 | |
| (c) | 1 | 1 | | V21 | V22 | V23 | V24 | V25 | V26 | V27 | V28 | V29 | V30 | |
| | | 0 | | V0 | V31 | V0 | V31 | V0 | V31 | V0 | V31 | V0 | V31 | |
| | | -1 | | V27 | V28 | V29 | V30 | V21 | V22 | V23 | V24 | V25 | V26 | |
| | 0 | 1 | | V22 | V23 | V24 | V25 | V26 | V27 | V28 | V29 | V30 | V21 | |
| | | 0 | | V31 | V0 | V31 | V0 | V31 | V0 | V31 | V0 | V31 | V0 | |
| | | -1 | | V26 | V27 | V28 | V29 | V30 | V21 | V22 | V23 | V24 | V25 | |

Figure 4 depicts the structure of DTC of 5-phase induction machine. Most components employed in conventional DTC are maintained in order to retain simple structure of DTC. Minor modifications on the

original DTC structure were done, particularly in introducing three sets of look-up table (as given in Table I) and calculating the d-axis and q-axis components of currents and voltages based on 5-phase system. Note that, the rotor speed information (obtained from speed sensor) is required to determine the optimal vector to achieve desired improvements.

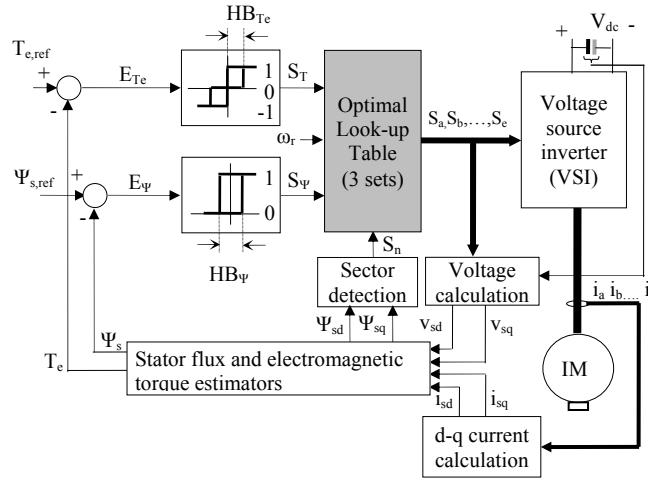

Figure 4. Structure of DTC of five-phase induction machine

4. SIMULATION RESULTS

Simulations were conducted using Matlab/Simulink to compare DTC performances for different applications of voltage vectors (i.e. shortest amplitude, medium amplitude and longest amplitude). For simplification in comparing the performances, a step change of reference torque from 0.5 p.u to 1.0 p.u is applied for every application of amplitude vector, as shown in Fig. 5. The zoomed images of the results shown in Fig. 5, are also given in Fig. 6 to present clearly the effects of torque regulation/slope.

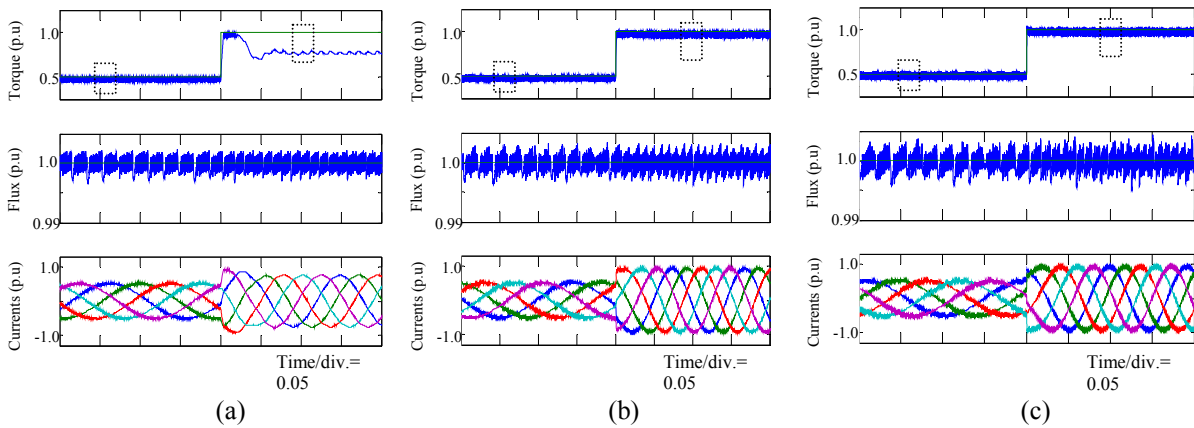

Figure 5. Simulation results of output torque, stator flux and stator currents with a step change of reference torque for different amplitude of voltage vector (a) smallest amplitude, (b) medium amplitude and (c) longest amplitude.

From the results obtained, the torque and flux ripples were reduced with the application of the smallest voltage vector. Moreover, this selection of vector results in lower switching frequency which may improve the efficiency of DTC drive system. However, the DTC performance in controlling the torque at rated condition deteriorates if the smallest amplitude of vector applied, particularly at high speed operations. In such condition, it is clearly seen that the torque regulation is excellent with the application of the longest

amplitude of vector. Thus, the capability of torque regulated at its rated during motor acceleration can be further extended by applying the longest amplitude of voltage vector.

Figure 7 compares the torque dynamic performance of the three applications under the same test (as performed in Figures. 5 and 6). It can be clearly noticed from the figure that the fastest torque dynamic performance can be achieved with application of the longest amplitude of vector. As discussed in previous section, the longest amplitude of vector results in the highest torque slope or rate of torque increases. Based on the results obtained, it can also suggest that the selection of medium amplitude of vector is preferable to obtain better torque regulation, particularly at middle speed operations.

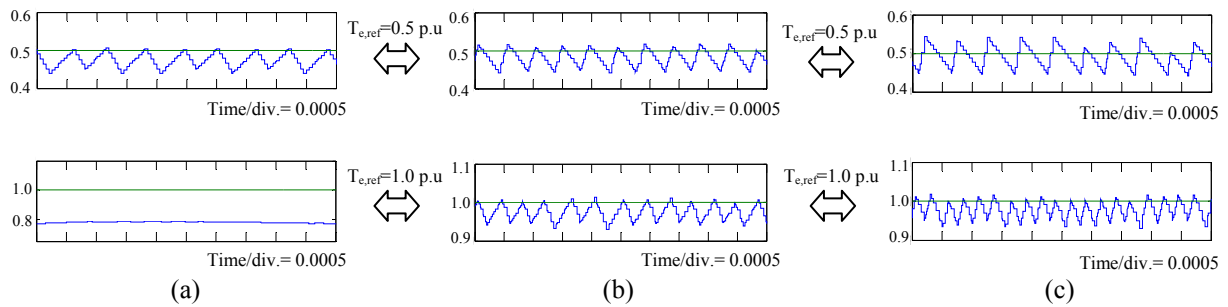

Figure 6. Magnified output torque waveforms for (a) $T_{e,ref} = 0.5$ p.u and (b) $T_{e,ref} = 1.0$ p.u., corresponding to the results obtained in Figs. 5(a),(b) and (c), respectively (i.e. area marked by dotted line).

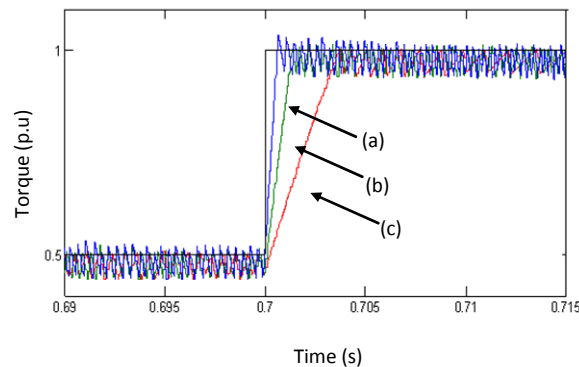

Figure 7. Comparison of torque dynamic performance for different application of voltage vectors (a) longest amplitude, (b) medium amplitude (c) shortest amplitude.

5. CONCLUSION

This paper has presented an optimal DTC switching strategy for five-phase induction machine. Three look-up tables consisting of voltage vectors with different amplitude were used to obtain the optimal switching strategy. It has shown that the DTC performances can be improved by selecting the most optimal vector which is different for every range of speed operation. Motor modeling of five phase induction machine is also discussed. The significance of the research is to highlight the potential of using five-phase DTC system that offers more options (i.e. number of switching vectors) in selecting the most optimal vector to achieve superior performance.

ACKNOWLEDGEMENTS

The authors would like to thank the Universiti Teknikal Malaysia Melaka (UTeM) for providing the ERGS/2012/FKE/TK02/02/2/E00010 for this research.

REFERENCES

- [1] L.-H. Hoang, "Comparison of field-oriented control and direct torque control for induction motor drives," in *Industry Applications Conference, 1999. Thirty-Fourth IAS Annual Meeting. Conference Record of the 1999 IEEE*, 1999, pp. 1245-1252 vol.2.
- [2] Z. Yu, J. Zhenhua, and Y. Xunwei, "Indirect field-oriented control of induction machines based on synergetic control theory," in *Power and Energy Society General Meeting - Conversion and Delivery of Electrical Energy in the 21st Century, 2008 IEEE*, 2008, pp. 1-7.
- [3] Blaschke, F., *The Principle of Field Orientation Applied To The Transvector Closed-Loop Control System For Rotating Field Machines*. Siemens Rev, May 1972. 34: p. 217-220
- [4] M. Ming, "Voltage Vector Controller for Rotor Field-Oriented Control of Induction Motor Based on Motional Electromotive Force," in *Industrial Electronics and Applications, 2007. ICIEA 2007. 2nd IEEE Conference on*, 2007, pp. 1531-1534.
- [5] J. N. Nash, "Direct torque control, induction motor vector control without an encoder," in *Pulp and Paper Industry Technical Conference, 1996., Conference Record of 1996 Annual*, 1996, pp. 86-93.
- [6] I. Takahashi and T. Noguchi, "Take a look back upon the past decade of direct torque control [of induction motors]," in *Industrial Electronics, Control and Instrumentation, 1997. IECON 97. 23rd International Conference on*, 1997, pp. 546-551 vol.2.
- [7] H. A. Toliyat and X. Huangsheng, "A novel direct torque control (DTC) method for five-phase induction machines," in *Applied Power Electronics Conference and Exposition, 2000. APEC 2000. Fifteenth Annual IEEE*, 2000, pp. 162-168 vol.1.
- [8] X. Huangsheng, H. A. Toliyat, and L. J. Petersen, "Five-phase induction motor drives with DSP-based control system," *Power Electronics, IEEE Transactions on*, vol. 17, pp. 524-533, 2002.
- [9] H. A. Toliyat, "Analysis and simulation of five-phase variable-speed induction motor drives under asymmetrical connections," *Power Electronics, IEEE Transactions on*, vol. 13, pp. 748-756, 1998.
- [10] E. Levi, R. Bojoi, F. Profumo, H. A. Toliyat, and S. Williamson, "Multiphase induction motor drives - a technology status review," *Electric Power Applications, IET*, vol. 1, pp. 489-516, 2007.
- [11] Casadei, D., Serra, G., and Tani, A. Analytical investigation of torque and flux ripple in DTC schemes for induction motors. 23rd International Conference on Industrial Electronics, Control and Instrumentation, 1997. IECON 97. 1997.
- [12] Jidin A., Nik Idris N. R., Mohd Yatim A. H., Sutikno T, and Elbuluk M. E., "Extending Switching Frequency for Torque Ripple Reduction Utilizing a Constant Frequency Torque Controller in DTC of Induction Motors", *Journal of Power Electronics*, vol. 11, no. 2, pp.148-155, 2011.
- [13] Jidin, A.B.; Idris, N.R.B.N.; Yatim, A. H B M.; Sutikno, T., "A Wide-Speed High Torque Capability Utilizing Overmodulation Strategy in DTC of Induction Machines With Constant Switching Frequency Controller," *Power Electronics, IEEE Transactions on*, vol.27, no.5, pp.2566,2575, May 2012
- [14] L. R. L. V. Raj, A. Jidin, C. W. M. F. Che Wan Mohd Zalani, K. Abdul Karim, G. Wee Yen, and M. H. Jopri, "Improved performance of DTC of five-phase induction machines," in *Power Engineering and Optimization Conference (PEOCO), 2013 IEEE 7th International*, 2013, pp. 613-618.

BIOGRAPHIES OF AUTHORS

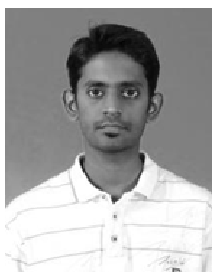

Logan Raj Lourdes Victor Raj was born in 1988 in Selangor, Malaysia. He received the B.Eng. degree (Hons) from the Universiti Teknikal Malaysia Melaka, Malaysia in 2012, where he is currently pursuing the M.Sc degree. His areas of research interest include vector control of ac machines and power electronics.



Auzani Jidin received the B.Eng. degrees, M.Eng. degrees and Ph.D. degree in power electronics and drives from Universiti Teknologi Malaysia, Johor Bahru, Malaysia, in 2002, 2004 and 2011, respectively. He is currently a Lecturer with the Department of Power Electronics and Drives, Faculty of Electrical Engineering, Universiti Teknikal Malaysia Melaka, Durian Tunggal, Malaysia. His research interests include the field of power electronics, motor drive systems, field-programmable gate array, and DSP applications.



Kasrul Abdul Karim received the M.Sc. from University of Bradford and Ph.D. degrees from the University of Nottingham, UK, in 2003 and 2011, respectively. He is currently a Lecturer with the Department of Power Electronics and Drives, Faculty of Electrical Engineering, Universiti Teknikal Malaysia Melaka, Durian Tunggal, Malaysia. His research interests include electrical machine design, power electronics, and electric vehicle.



Tole Sutikno is an expert in the field of power electronics, Industrial Electronics & Informatics, Embedded Systems and Electric Drives. Since 2001 he has been a lecturer in Electrical Engineering Department, Universitas Ahmad Dahlan (UAD), Indonesia. He is an Associate Professor at the above University since 2008. He received his B.Eng. and M.Eng. degree in Electrical Engineering from Diponegoro University, Indonesia and Gadjah Mada University, Indonesia, in 1999 and 2004, respectively. Currently, he is pursuing PhD degree at the Universiti Teknologi Malaysia (UTM), Malaysia. He is an Editor-in-Chief of TELKOMNIKA Indonesian Journal of Electrical Engineering, and also acts as an Editor in some international journals in electrical and computer engineering, power electronics, motor drive systems and FPGA applications areas.

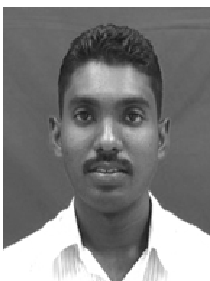

R. Sundram was born in 1989 in Penang, Malaysia. He received the B.Eng. degree (Hons) in Electrical Engineering from Universiti Teknikal Malaysia Melaka, Malaysia in 2012 and now he is currently pursuing the M.Sc degree in Power Electronics and Drive. His areas of research interest include Direct Torque Control of Multi Phase System and Power Electronics.



Mohd Hatta Jopri received Bachelor of Electrical Engineering from Universiti Teknologi Malaysia in 2001; and the MSc. Electrical Power Engineering from Rheinisch-Westfaelische Technische Hochschule Aachen (RWTH), Germany in 2011. He is a lecturer at Universiti Teknikal Malaysia Melaka (UTeM) since 2005. His research interest is power electronics and machine drives.