

Spring 2016

# ASME Mini-Baja RC CAR (Steering and suspension systems)

Michael E. Cox

Central Washington University, [coxmi@cwu.edu](mailto:coxmi@cwu.edu)

Follow this and additional works at: <http://digitalcommons.cwu.edu/undergradproj>

 Part of the [Applied Mechanics Commons](#), [Computer-Aided Engineering and Design Commons](#), and the [Manufacturing Commons](#)

---

## Recommended Citation

Cox, Michael E., "ASME Mini-Baja RC CAR (Steering and suspension systems)" (2016). *All Undergraduate Projects*. Paper 34.

This Undergraduate Project is brought to you for free and open access by the Undergraduate Student Projects at ScholarWorks@CWU. It has been accepted for inclusion in All Undergraduate Projects by an authorized administrator of ScholarWorks@CWU.

# ASME RC BAJA CAR: Suspension and Steering Systems 2015-16

By  
Michael Cox

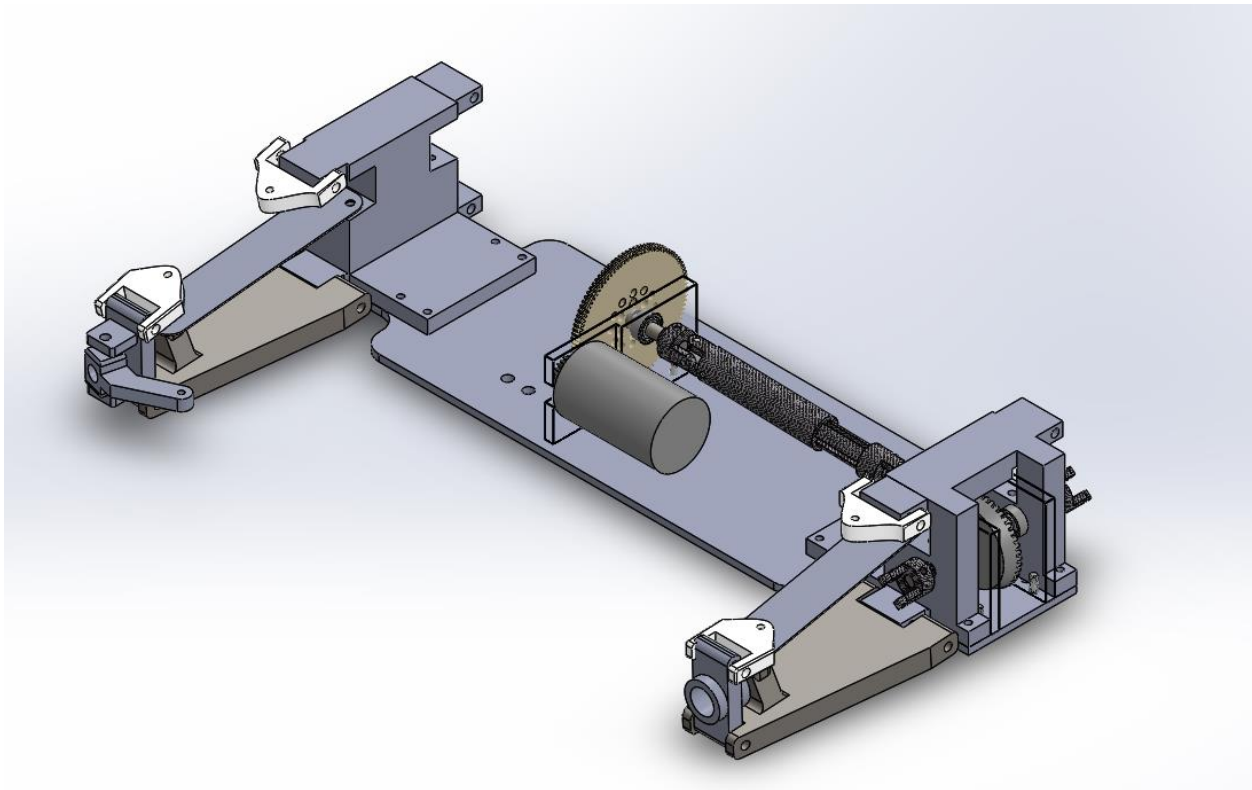

MET 495A

10/12/15

Partner: Jason Moore (Drive Train)

# Table of Contents

I: Table of Figures.....	4
1: INTRODUCTION .....	6
<b>1a: Motivation:</b> .....	6
<b>1b: Function Statements: Suspension and Steering:</b> .....	6
<b>1c: Requirements:</b> .....	6
<b>1d. Engineering Merit</b> .....	6
<b>1e. Scope of Effort</b> .....	7
<b>1f. Success Criteria</b> .....	7
2: DESIGN & ANALYSIS .....	7
<b>2a. Approach: Proposed Solution</b> .....	7
<b>2b. Description</b> .....	7
<b>2b. Benchmark</b> .....	8
<b>2c. Performance Predictions</b> .....	8
<b>2d. Description of Analyses</b> .....	8
<b>2e. Analysis</b> .....	9
<b>2f. Design Changes</b> .....	14
3. METHODS AND CONSTRUCTION.....	15
<b>3a. Methods and Construction</b> .....	15
<b>3b. Description</b> .....	15
<b>3c. Drawing Tree, Drawing ID's</b> .....	16
<b>3d. Parts list, ID labels, and estimated budget.</b> .....	16
<b>3e. Manufacturing issues</b> .....	16
4. TESTING METHOD.....	17
<b>4a. Introduction</b> .....	17
<b>4b. Methods/Approach</b> .....	17
<b>4c. Test Procedure</b> .....	18
<b>4d. Deliverables</b> .....	18
5: BUDGET, SCHEDULE AND PROJECT MANEGEMENT .....	19
<b>5a: Proposed Budget and Funding Source</b> .....	19
<b>5b: Suppliers and Part/Material Acquisition:</b> .....	19
<b>5d: Labor</b> .....	19
<b>5e: Estimate total project cost</b> .....	20

<b>5F. Proposed schedule</b> .....	20
I. Gantt Charts.....	20
II. Milestones.....	20
III. Estimate Total Project Time .....	20
<b>5G: Project Management</b> .....	20
I. Human Resources:.....	21
II. Physical Resources/Soft Resources:.....	21
<b>6. CONCLUSION AND DISCUSSION</b> .....	21
6a: Design Evolution.....	21
6b: Project Risk analysis.....	22
6c. Successful.....	22
6d. Next phase.....	22
6e. Acknowledgements .....	22
<b>Appendix</b> .....	23
<b>Appendix A – Analyses</b> .....	23
<b>Appendix B – Sketches and Drawings</b> .....	40
SKETCHES .....	40
DRAWINGS .....	43
<b>Appendix C – Parts List</b> .....	51
<b>Appendix D – Budget</b> .....	52
<b>Appendix E -- Schedule</b> .....	52
<b>Appendix F– Test Summary Data Sheets</b> .....	54
<b>Appendix G– Resume/Vita</b> .....	56
<b>Appendix H FEA (Finite Element Analysis Reports)</b> .....	57
FEA REPORT 1.01.....	57
FEA REPORT 1.02 ABS .....	64
FEA REPORT 2.50 ABS .....	71
<b>Appendix I FINAL TESTING DOCUMENT</b> .....	78

## I: Table of Figures

Figure 1 .....	10
Figure 2 .....	10
Figure 3 .....	11
Figure 4 .....	11
Figure 5 Front Assembly. ....	12
Figure 6 Rear Assembly.....	12
Figure 7 Complete Assembly.....	13
Figure 8 Energy of car dropping and force applied. ....	23
Figure 9 Statics for force applied to leaf spring.....	24
Figure 10 Leaf Spring Dimensions .....	25
Figure 11 Fastener shear analysis. ....	26
Figure 12 Impact Force of vehicle @ 20MPH.....	27
Figure 13 First Step in FEA of A-Arm 1.0 .....	28
Figure 14 FEA of A-Arm 1.02 part 2 .....	29
Figure 15 FEA A-arm Part 3 (2.0 ABS) .....	30
Figure 16 Final FEA of A-Arm 2.0 STEEL .....	31
Figure 17 Steering Knuckle Modification Geometry .....	32
Figure 18 Ackerman Angle Part 1 .....	33
Figure 19 Ackerman Angle Part 2 .....	34
Figure 20 Ackerman Angle Part 3 .....	34
Figure 21: .....	35
Figure 22: .....	36
Figure 23 First attempt at leaf spring statics (unused design iteration) .....	37
Figure 24 K value of a linear Spring (unused design iteration).....	38
Figure 25 First attempt at leaf spring dimensions(unused design iteration) .....	39
Figure 26: Parts list and preliminary assembly sketch.....	40
Figure 27 Initial Sketch of Assembly (unused design iteration).....	41
Figure 28 Initial Design of Rear Assembly (unused design iteration).....	42
Figure 29 FRONT ASSEMBLY.....	43
Figure 30 FRONT END ALL-MOUNT .....	43
Figure 31 A-ARM (FINAL REVISION).....	44
Figure 32 CASTER BLOCK .....	44
Figure 33 CAMBER ARM CONNECTOR B SIDE .....	45
Figure 34 CAMBER ARM CONNECTOR C SIDE .....	45
Figure 35 LEAF SPRING FRONT AND REAR .....	46
Figure 36 STEERING KNUCKLE LEFT .....	46
Figure 37 STEERING KNUCKLE RIGHT .....	47
Figure 38 CENTER LINK .....	47
Figure 39 REAR ASSEMBLY .....	48
Figure 40 REAR ALLMOUNT/HOUSING .....	48
Figure 41 REAR A-ARM .....	49
Figure 42 HUB CARRIER .....	49
Figure 43 CHASSIS PAN.....	50
Figure 44 Fall Schedule .....	52
Figure 45 Winter Schedule (a) and Detailed.....	53

Figure 46 Spring Schedule.....	53
Figure 47 Milestone Schedule .....	54
Figure 48 Full Year Schedule .....	54
Figure 49 Drop Test Data Summary Sheet.....	55
Figure 50: General Resume .....	56

# 1: INTRODUCTION

## 1a: Motivation:

The purpose of this project is to design and build a suspension, and steering system for a new CWU mini-Baja RC car that can race in the 2016 ASME Radio Controlled Baja Car Contest, and fill all of the mandatory requirements of the contest. My partner Jason Moore will be designing the drive systems and we will collaborate on final assembly.

## 1b: Function Statements: Suspension and Steering:

The suspension must be able to withstand the rigors of the competition's course by supporting the vehicle without bottoming out and absorb shock sufficiently enough to prevent damage to any parts of vehicle. The steering must operate in a predictable manner and turn the vehicle in a fairly small radius so it will be easy to steer through complex obstacles and terrain.

## 1c: Requirements:

The following list further defines the function and required abilities of the systems that will be designed and built for this project.

- Shocks will have to be designed that can dampen the force of a drop from up to 24 inches.
- Suspension must support up to four pounds from a drop of 24 inches without chassis.
- Suspension must have at least 1.5" of up travel.
- Steering and suspension systems must operate, and articulate fully without interference between components.
- Steering system must allow vehicle to turn 180 Deg. in a 50" radius
- As per competition rules 20% of steering components must be store bought.
- As per competition rules design 50% of parts for interchangeability to allow for smaller parts stock.
- Systems must be fastened together with easily sourced fasteners.

## 1d. Engineering Merit

The purpose of this project is to design and build a steering and suspension system for an ASME Baja Car. The focus of the design is to improve upon last year's car. The engineering merit will be in designing a system that will not have any of these problems. For example the impact force of the vehicle dropping from a height of 24" will have to be quantified so that I can begin designing a spring with enough resistance to absorb the shock without bottoming out on impact, but it must be able to be installed on the current chassis pan. I will also have to use a combination of geometry and statics to design the linkage for steering and suspension systems.

### **1e. Scope of Effort**

The scope of this project is to design/build and optimize the suspension and steering system for a 1/10th scale RC Baja car that will comply with all ASME R/C Baja rules and can complete the completion without any catastrophic failure that would prevent the vehicle from finishing the competition. The current chassis pan and some components of the suspension and steering systems will be used, all other parts will be manufactured or purchased. The drive train of the car will be designed by my partner (Jason Moore), and finally assembly and completion will be completed by the both of us.

### **1f. Success Criteria**

The criteria for the car to be successful is that the vehicle will be capable of competing in the 2015-16 ASME Baja in all events. The vehicle must race without falling apart, breaking or any other type of catastrophic failure that would prevent it from finishing the competition. Success will be achieved when the vehicle has competed in all events and is still in operating condition.

## **2: DESIGN & ANALYSIS**

### **2a. Approach: Proposed Solution**

The proposed solution is to design and build a suspension and steering system for this year's ASME Baja vehicle. For the purpose of limiting the projects scope and to keep budget under 225\$ we will be using some parts that are left over from last year's project. Currently the pieces that are going to be used are a .1325" 1061 AL chassis pan, steering knuckles, modified caster blocks, and modified hub carriers.

### **2b. Description**

The primary structural component of the suspension is the A-arm. The A-arm is the main connector between the chassis pan and the caster block on the front end, and the hub carrier on the rear end. The A-arm will be hinged at either end to allow vertical travel between chassis and wheel. Because of the vertical travel between the wheel and the chassis, there must be a component to adjust the vertical angle of wheel (camber). Camber is the relationship of the tire to the ground, such that a tire that is perpendicular to the racing surface has zero camber. Changes in camber alter how much surface contact there is between the tires and the track surface during turns. Camber can be adjusted to a make cornering more or less aggressive. There will be more than one driver during the different events of the competition, so to compensate for different driving styles and events the camber arms will be adjustable. An adjustable (threaded shaft) camber arm will go between the caster block (and hub carrier) and the shock towers.

The shocks will be a leaf spring that will run in-between the A-arm and the shock towers. The springs will hold up the vehicle, help prevent it from leaning in sharp turns. The all mount



(as its name implies) serves as a mounting block for the A-arm, Leaf Spring, and camber rod connectors.

The vehicle will be steered in the front end and will be rear wheel drive. For the front end the A-arm will have a hinge pin mounted caster block that will also connect the camber arm to the all mount. A kingpin will mount the steering knuckle to the caster block. The steering linkage will attach to the steering knuckle and connect the steering servo to the wheels. The stub axle is also affixed to the Steering knuckle and the wheel freely spins upon it.

The rear wheel suspension will be similar to the front except instead of a caster block, a hub carrier will be mounted to the end of the A-arm. The rear camber arm will also attach to the hub carrier. The hub carrier supports and allows the drive shaft to transmit power to the stub axle, which will be equipped with a drive hex and nut to ensure no slipping between the drive shaft and wheel. To account for the change in drive shaft length during the vertical travel between the chassis and the wheels there will be a slide style drive shaft and a hinged differential out drive (drive components will be designed by my partner Jason Moore).

The steering linkage will be powered by a two directional servo. The servo will mount to the chassis and move the linkage to apply force into the steering knuckle to turn the vehicle. The steering linkage will have to be pinned to the chassis at two locations so that it will be possible for the linkage system to apply more movement to the tire that is on the inside of the turn.

## **2b. Benchmark**

The purpose of this project is to build and design a new ASME Baja vehicle using an identical chassis pan as well as some other identical parts from last year's model. So the benchmark for this device will be last year's ASME Baja vehicle. If last year's model is not in working condition or capable of being a benchmark at time of completion, then a Traction Stampede VXL, which is an electric RC stadium truck, will be used as a benchmark. The Traction Stampede is manufactured to withstand rigors similar to those that will be found at the competition course, so it should be a suitable benchmark.

## **2c. Performance Predictions**

The suspension system will be able to articulate freely without interference over a 1.5" static height differential. The suspension system will support the 4lb vehicle and sufficiently dampen the impact of a 24" drop without the chassis pan touching the track surface. At a peek turn the inside wheel will turn to an angle which the vehicle achieves a turn radius of 50". The vehicle will be able to steer consistently without any interference of components.

## **2d. Description of Analyses**

The geometry of the A-arm will have to be long enough to extend the wheel far enough from the chassis plate to prevent interference between the two parts as well as travel the 1.5" vertical differential. As well as skinny enough to allow steering to articulate the tires. It must also be capable of supporting the vehicle without deforming. Apply a geometric analysis to design of A-arm shape and use the finite element analysis available in Solidworks.

The camber arm must be of a shape that will keep the tire at zero camber. The steering linkage must have a geometrical shape that will allow the tire on the inside turn to at greater angle than the tire on the outside of the turn. The steering linkage must also apply enough force to overcome the friction resistance in the linkage as well as the lateral force applied to the tire by the road.

## **2e. Analysis**

### **I. Approach: Proposed Sequence of analysis:**

The following proposed sequence of analysis will be a guide in the process of analyzing the project.

- Use energy analysis to determine forces applied to suspension system at a max height drop.
- Use equations of equilibrium to determine forces applied to leaf spring in suspension system.
- Use cantilever beam analysis to determine geometry and travel of leaf spring.
- Use Solidworks assembly to determine that there will be no interference between components of either steering or suspension systems.
- Use Solidworks to analyses and evaluate stress concentrations in A-arm.
- Apply shear flow analysis of fasteners to determine safety factor to shear.
- Determine drive angles of vehicle to complete a 50" radius turn.
- Determine Ackerman angle using geometric analysis.

### **II. Analysis of Suspension**

The first step in analyzing the suspension was to determine the amount of force the leaf spring needed to carry to support the vehicle. It is expected the completed weight of the vehicle will be 4 lbs., and it will be supported by four tires. Due to the fact that the vehicle will land on one wheel prior to the others the leaf spring will be analyzed supporting the whole weight of the vehicle on one tire. This force was determined to be 128.8 pounds (analysis in Figure 8).

After determining the force applied to the wheels, a static analysis was performed to determine the force applied to the leaf spring was 88.702 lbs. (static analysis Figure 9). At that point a material was chosen for the leaf spring, the material selected was AISI 1095. This material was chosen because it is easy to acquire and the modulus of elasticity is 29000 ksi, which makes it a good steel for a spring.

Once material was selected the dimensions for the leaf spring needed to be determined. The cantilever beam equation was used to determine the final dimension (width) by inputting thicknesses that were available for purchase, the final dimensions of the spring were determined to be 2.65"x1.98"x.042" . (Cantilever beam and dimensions Figure 10)

As per competition standards a standard fastener will be used, the #6 phillips pan head machine screw was chosen because we have many of them and they are free. In prior years a source of failure for 1/10<sup>th</sup> scale Baja cars has been shearing of the fasteners that connect the

suspension frame together. To avoid this a shear analysis was completed on the #6 machine screw fasteners that will be used in the construction of the vehicle. Based on the assumption that the leaf spring and the tires fail to absorb any of the impact the fasteners in the A-arms will have to be able to withstand the 64.4 pounds of force applied to their cross-sectional area. Through a shear analysis it was determined that the machine screws has a 9.65 safety factor when experiencing this load (for fastener analysis see Figure 11)

To determine the structural capacity of the A-arms a finite element analysis is necessary due to the complex geometry of the part. The first step in this process was to approximate the maximum force the part will have to endure. Given the vehicles estimated weight of 41b. and an estimated top speed of 20 mph. if the vehicle impacts a wall and the force of impact is split into the two front wheel components the force that a single side receives is 586 lbs. (for analysis see Figure 12). But being that the vehicle will is designed only for top speed burst in slalom, cruising speed (10 mph) is the estimated speed for negotiating the obstacle course, so the force will be reduced to 292 lb. force..

To increase the accuracy of the Solidworks F.E.A. of the a A-arms material data was gathered for printed ABS plastic via matweb and through course work (MET 418 Printed Material Spec Sheet). The first design iteration A-arm 1.01 (Fig. 1) failed, it yielded in multiple locations and had a minimum safety factor of .05. (Full detailed F.E.A. reports on all tested parts in **Appendix H FEA (Finite Element Analysis Reports).**)

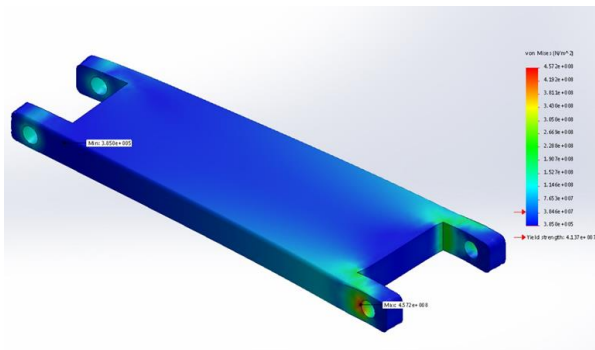

Figure 1

The second design A-arm 1.02 (Fig. 2) had channels installed as well as the tower for the leaf spring mount. Adding channels and giving the A-arm an I-beam like structure was unfortunately not enough to strengthen the part sufficiently. A-arm 1.02 failed though it only yielded at one location and the safety factor was brought up to .07 it was still not even close to being an acceptable part

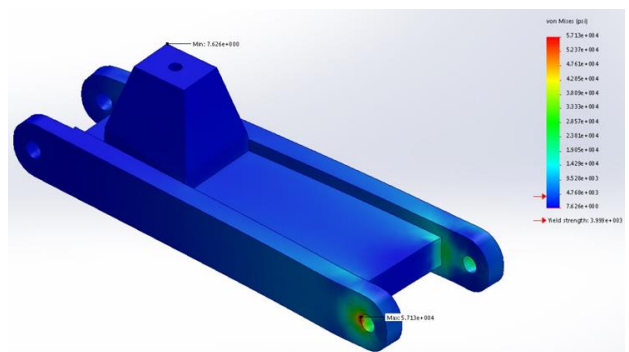

Figure 2

At this point in the analysis process it was determined that the part needed to be redesigned. The part needed to distribute the load more symmetrically and use more material. The solution was a more triangular A-arm with a wider base.

A-arm 2.0 (Fig. 3) was the next design iteration to be tested in Solidworks. Unfortunately it was also a failure. A-arm 2.0 ABS yielded in one location and had a low safety factor of .05. Because the geometry of the part was almost maxed (i.e. the base was within .02” of as wide as it could get without interference from other parts) the solution was in changing area of stress, so the next design had a greater pin diameter.

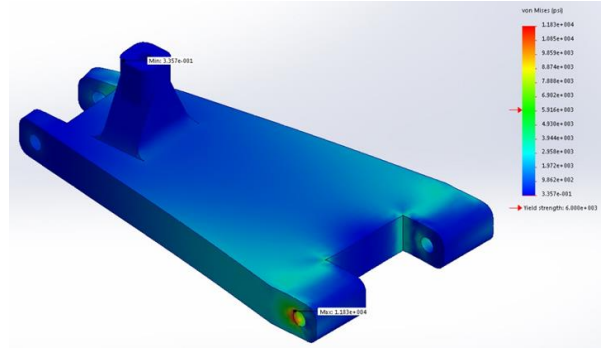

Figure 3

The next design iteration was A-arm 2.50 ABS (Fig. 4). After increasing the diameter of the A-arm connection pins to .375” and widening the base of the part by .25” the safety factor was increased to 1.12. This is an acceptable number because the speed used to estimate the force applied to the A-arm is twice what speed the vehicle will be negotiating obstacles.

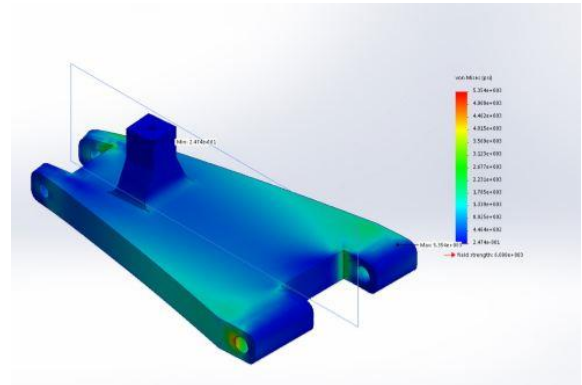

Figure 4

### III. Analysis of Steering

To retro fit last year’s steering components properly a geometric analysis was done to determine the new angle of the steering arm components. Adjustments were made to components and the steering angle was determined to be 73 degrees. To determine Ackerman angle another geometric analysis was applied via Solidworks to determine difference in angle between the two tires during a full turn. Attempting a turn approximately 8ft in diameter requires the inside wheel to have a difference of angle of .6 degrees. This value was smaller than initially anticipated, so another analysis was done to determine the difference between angles in a much smaller turn (25” radius). The results indicated that only a 3 degree change to the inside tire needs to be made. This can easily be accomplished due to the fact that the threaded rods that the steering linkage is comprised of are adjustable in length. This will provide a turning radius that should be well under the required 50” in radius turn. (Ackerman analysis provided in Figure 17, Figure 18, Figure 19, and Figure 20)

### IV. Device Assembly:

The vehicle will be composed of a chassis pan, which will act as the vehicle frame, and two assemblies mounted to the chassis pan. One is the drive train, which will be designed and

manufactured by my partner Jason Moore, the other is the steering/suspension assembly. The steering/suspension assembly is composed of two sub-assemblies, one of which is composed of still 2 more sub-assemblies (Table 1 Drawing Tree). The front end assembly, which differs from the rear in that it has steering knuckles instead of hub carrier. The rear assembly has forked towers to accommodate the drive shafts. All Sub-assemblies shown below are shown only for left side and without the connecting steering linkage or camber rods. Due to the fact that those components will be purchasing, and the home computer that the modeling was done on cannot load a completed assembly without crashing.

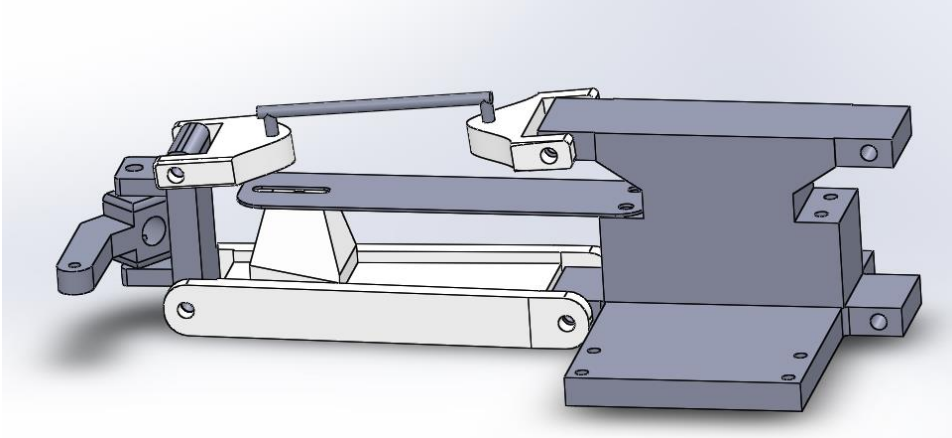

Figure 5 Front Assembly.

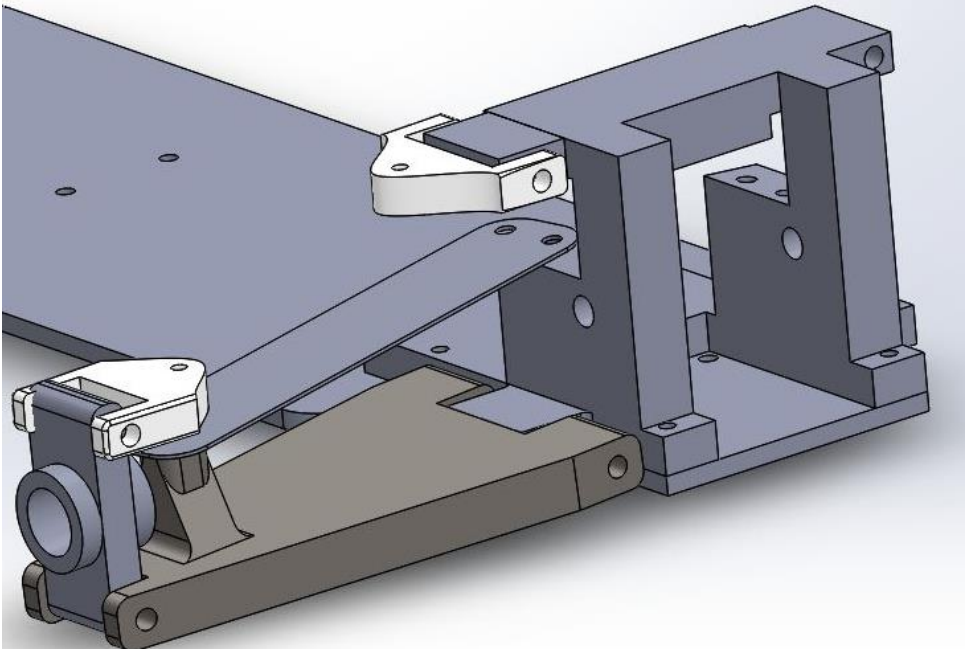
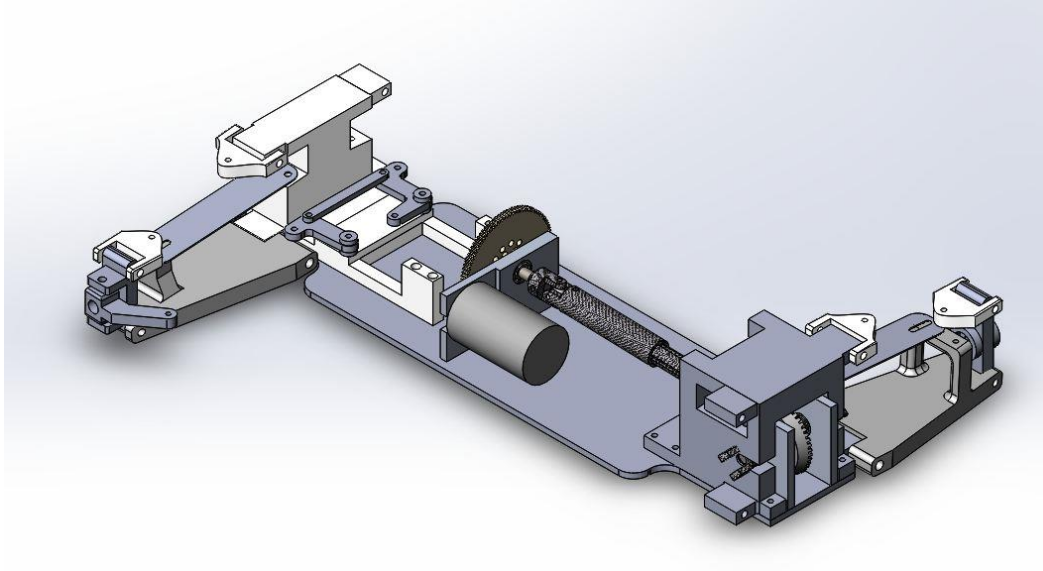

Figure 6 Rear Assembly



*Figure 7 Complete Assembly*

#### **V. Attachments and Store bought components,**

As per completion rules at least 20% of stock components must be bought and 50% allow for interchangeability:

- Linkage for steering system and camber rods.
- Tires.
- All fasteners will be #6 machine screws.
- Steering servo.
- Wheel nuts and drive nuts
- Stub axles.



## 2f. Design Changes

During the manufacturing phase of the project it became clear that some changes to the original design were necessary. The first design change was due to the fact that the steel that was intended to be used for the leaf springs was insufficient, and deformed under far too little stress. Due to lack of funding the original steel that was intended to be used as the leaf springs was unavailable. In its stead we attempted to use a steel with a lower spring constant and the results were unacceptable, the material deformed during the installation process. The solution was to mount the spring shocks used on last year's ASME mini-Baja car by drilling a hole through the leaf spring mounts on the A-arm and attach the top of the leaf spring to the camber mounts. The results were functional, an analysis was already completed during the preliminary design phase, and the solution did not require increasing the budget of the project. The design change is shown below.



*Design Change Shocks 1*

The next need for a design change occurred during the testing phase of the steering systems. The first impact the vehicle received during the testing phase broke the front right side flange that connected the A-arm. Due to the fact that one of the goals of the project was to 3-d manufacture all of the mounting hardware, the part was redesigned to a max geometry. This also broke during testing at this point, and after evaluating the broken part it was discovered that small radiused in the printed parts had tiny air gaps printed into the part, this was the assumed reason of failure. It was then decided that to meet deadlines, a design change in materials was necessary. This was accomplished by milling out a 3"x.875"x.375" strip of the all mount and then bolting in a like sized piece of aluminum, which was then used as the flange for mounting the A-arms (design change shown below). So far the vehicle has performed admirably during testing and has not failed in any more locations.



*Design Change A-all mount 1*

## 3. METHODS AND CONSTRUCTION

### 3a. Methods and Construction

There will be one primary type of manufacturing method used for the steering and suspension systems, although there will be a significant portion of parts purchased as per competition rules and to narrow the scope of developing two separate systems.

The primary method will be three dimensionally printing parts for the driving and steering components. The parts will be printed from ABS plastic. This will be completed in the CWU rapid prototyping lab on campus. The rapid prototyping lab is especially useful for the all mounts (front and rear) due to their complex geometry they would be especially difficult to machine.

The secondary method of manufacture and modification will be machining. The front All Mount had a 3"x .875"x .375" groove milled out of the bottom to fit in a strip of aluminum. The aluminum strip was also milled from a 1"x 1"x .375" to the approximate dimensions of 1"x.875"x.375".

### 3b. Description

The Steering system and the suspension system (including the steering servo) will all mount to a single part and that will attach to the chassis pan, there will be one for the front and one for the rear. This will allow the systems to be taken on and off the vehicle in a modular fashion.

The rear end will also be put together in such a fashion, that the drive housing will mount to the rear suspension assembly. This will allow the back end to be modular as well as the front end, and the drive train as well. Making the different systems on the vehicle modular allows future students to easily narrow their scope on what they want to accomplish for future projects.



### 3c. Drawing Tree, Drawing ID's

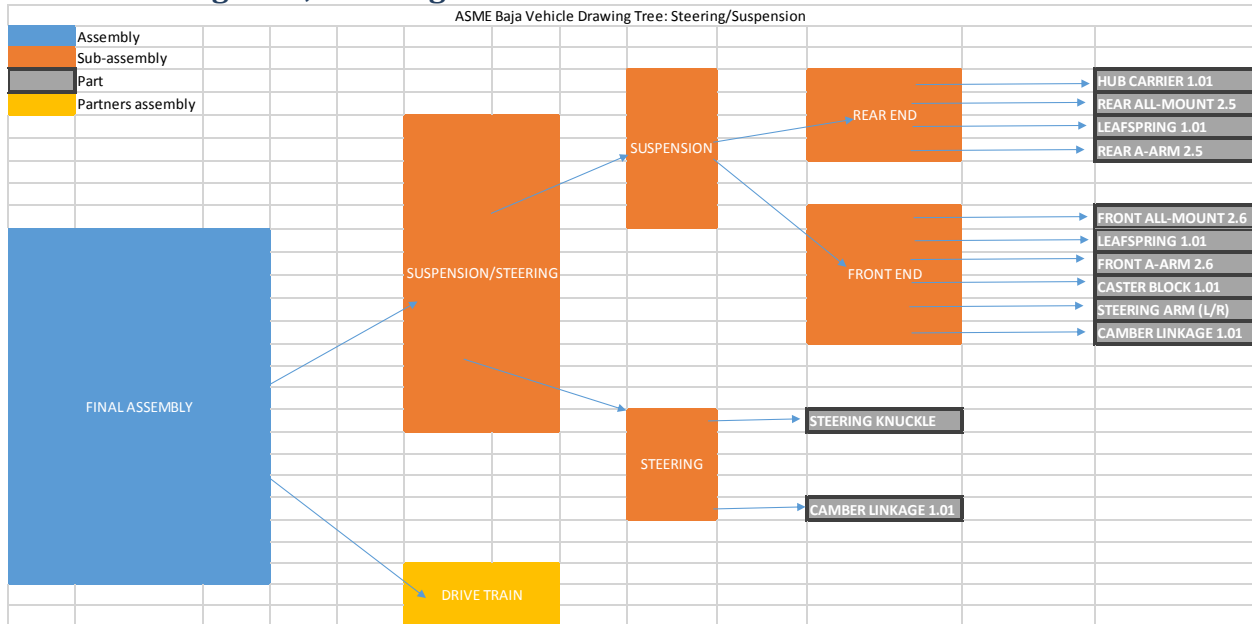

Table 1 Drawing Tree

### 3d. Parts list, ID labels, and estimated budget.

Parts List and ID labels				
Part #	Name	Unit Cost (\$)	Qty.	Total Cost
1	A-arm	\$ 2.50	4	\$ 10.00
2	Caster Block	\$ 5.00	2	\$ 10.00
3	Steering knuckle	\$ 3.00	2	\$ 6.00
4	Hub Carrier	\$ 5.00	2	\$ 10.00
5	Stub Axle	\$ 2.80	1	\$ 2.80
6	King pin	\$ 11.80	1	\$ 11.80
7	Wheel Nut	\$ 4.00	1	\$ 4.00
8	Threaded Camber Link	\$ 6.99	1	\$ 6.99
10	Drive Hex	\$ 5.99	1	\$ 5.99
11	Tires+Wheels	\$ 22.89	1	\$ 22.89
12	Leaf Springs	\$ 7.99	2	\$ 15.98
13	Steering Servo	\$ 8.00	1	\$ 8.00
14	Steering Arm	\$ 3.00	2	\$ 6.00
15	Threaded Steering Linkage	\$ 15.00	1	\$ 15.00
17	All mount	\$ -	0	\$ -
18	Hub Nut	\$ 4.99	1	\$ 4.99
				\$ 140.44

Table 2

### 3e. Manufacturing issues

The biggest issues with manufacturing currently is cost and time. The available ABS and other house made components will not be difficult to manufacture but scheduling time in the shop has been an issue in the past. The three dimensional printer is also a low cost method that is readily available in the building, but as it is available for other students as well, scheduling time on the machine may be also be an issue.

To date the biggest issue with the rapid prototyping manufacture method is in the printed holes. There are many holes in the parts to provide locations for fasteners. The holes are often printed oblong, and slightly smaller than modeled. Holes that are printed adjacent to a wall (within .25") often produce a bulge in the wall. The front and rear mounting components were not printed perfectly flat either, however this did not prove to be an issue in assembly so no action was taken to correct the issue.

To fix the issues with the oblong holes, each fastener location was drilled out. Drilling out each fastener location actually proved to be quite beneficial when it came assembling the components onto the chassis plate. Assembled components were clamped into place onto the chassis pan and then drilled out through the chassis pan. This made for very concentric mounting holes in the chassis pan.

The only location where bulging occurred that effected assembly was in the rear mount. The drive train is also modular and was designed to slip into the rear mounting unit. Bulging occurred on the inside of the drive train location slot. To fix this issue both the rear all mount and the drive train motor mount were sanded down to provide a clean and interference free assembly.

## 4. TESTING METHOD

### 4a. Introduction

The primary method intended to test the functions of the vehicle are different obstacles found on campus and some courses that will simulate the predicted rigors of the competition. This will include obstacles with different height drops, different surfaces can be found all over campus, and the FLUKE lab in Hogue will provide a wide enough space to test top speed and slalom abilities. The vehicle will only be tested as a whole while completely assembled. The testing will focus on the requirements listed in 1c: Requirements.

### 4b. Methods/Approach

Most of the test environment for the vehicle systems will be found on campus or constructed on campus in the Hogue FLUKE lab. The indoor lab is a convenient location for testing, it is free, out of the weather and generally at a consistent humidity and temperature. A variety of different surfaces such as bark, grass, gravel, concrete, asphalt, and wood sheeting can all be found and is readily available on campus. Card board boxes, 2x4 and a bottle jack will be used to make a platform of adjustable height, to test vehicle drops from different levels. A measuring tape will be needed to measure obstacle lengths and heights. Calipers will be used to measure the amount of travel of the steering and suspension components. Masking tape will be

used to mark locations for testing steering accuracy, as well as used in outlining a turning radius. A cell phone will also be used as an accelerometer, stop watch, camera, and recording device. All of the equipment necessary for the proposed testing methods is readily available for free, for this reason testing is currently omitted from cost and budget. The speed and slalom test will be covered by my partner Jason Moore, as the drive train components are key to predictions and testing.

#### **4c. Test Procedure**

To test the ability of the shocks to dampen the force developed in a 24” drop without any parts failing, the vehicle will drive off a box at a measured height. The vehicle must have its weight recorded as well as all of the heights as well. The test is pass/fail. If all systems on the vehicle operate after the drop than it is a pass if there is failure then it is a fail.

To determine if the vehicle is interacting with the track surface upon impact after a 24” drop the bottom of the vehicle will be brushed with a surface stain. The vehicle will then be dropped from 24” onto a clean paper surface. The surface stain will mark the clean paper and indicate if the vehicle is contacting the surface after the impact. This test is pass/fail.

To test the vehicles ability to climb over a 1.5” height differential. A 2x4x1.5 piece of lumber will be weighted to the floor in the Hogue fluke lab and the vehicle will attempt to climb over the obstacle. The test is pass/fail. If the suspension articulates the desired 1.5 inches and the vehicle is able to climb over the obstacle then the test is a pass if not a fail.

To test that steering is articulating properly and not interfering to the point of failure. The assembly will be tested in Solidworks.

To test the vehicles ability to drive in a predictable matter a straight lane 12’ wide and 25 feet long will be outlined in masking tape on the FLUKE lab floor. The vehicle will be placed in the center of the lane and will have to drive from on end to the other without steering and without driving outside of lane, or otherwise deviating more than 6” off course either of which will be considered failing the test.

To test the turning radius an arc with a 50” Radius will be outlined on the FLUKE lab floor in masking tape. The vehicle will have to complete a turn without exceeding the radius of the turn. The test is pass/fail, if vehicle stays within outlined arc it is a pass.

#### **4d. Deliverables**

At time of test summary data sheet for each test will be created and used to determine success of the test. The summary sheets will record the requirement being tested, the predicted results, the methods of testing, and a pass/fail section entailing performance of the vehicle. The summary sheet will act as a way to document success, or if a failure is present than a first step

towards a solution. Test Summary Data Sheet sheets in **Appendix F– Test Summary Data Sheets** .

## 5: BUDGET, SCHEDULE AND PROJECT MANAGEMENT

To ensure success of this project several steps will be taken to manage the three most common causes of project failure: cost, time management, and project management. The first is to create a budget in an effort to control cost. The second is to create a schedule, and define milestones to track the progress of the project. A budget and a schedule are helpful tools that will help in the management of the project.

### 5a: Proposed Budget and Funding Source

The primary and only funding source is me, and being that I am the soul source of funding I am going to try to keep the budget low. The benchmark for the budget is \$300, which is the estimate I was given for the project last year. I would like to cut that by 25% and have a maximum budget of 225.00\$. An estimated cost list (Table 3 Early parts list and estimate on budget.) was created during the process of creating a parts list. A more accurate budget (in Table 4 Budget) details cost and suppliers for the project, and to this point is just over 210\$ and ideally it will decrease. Cost will play a large role in design decision and will likely change as the project evolves.

### 5b: Suppliers and Part/Material Acquisition:

A significant amount of material is available from last year's project and will be used for the large or structural components, such as chassis pan, steering knuckles, hub carriers, steering linkage, and fasteners. These Material will require machining or some type of shaping that will take place in the CWU machine shop. Some of the parts will also be printed from the CWU rapid prototyping lab. I will be doing the work myself, therefore I will not be charging myself for the work, though I will record my hours in the shop.

Parts that will not be manufactured at CWU will be ordered online. Parts and fasteners will be purchased from different merchants, through Amazon.com. Purchasing through one website will simplify ordering, and amazon.com has good return policies as well as competitive pricing.

### 5d: Labor

Assembly and any necessary modifications or addition machining of parts will be completed by me, in the available shops in the Hogue technology building. As briefly discussed in the prior section I will not be charging myself for any of the time spent working on the project. Predicting the time it will take to machine, and print the parts will be difficult as the machine shop is very busy during winter quarter, especially this year considering the size of our class.

Some parts will be machined out of 1/4" 1023 carbon steel plate. The material is available for free, but the machining I will have to complete. Budget will be updated upon information availability.

## 5e: Estimate total project cost

The current estimated cost of this project is 140.44\$ (Table 4 Budget). This is below the proposed budget of 225.00\$. Price is a large factor in determining design for this project, and as design continues the predicted budget should decrease. This estimate is optimistic, but if the A-arms and supports can be machined for free then cost will dramatically decrease.

## 5F. Proposed schedule

### I. Gantt Charts

Gantt Charts will be used to schedule different aspects of the project. Gantt charts are useful tools for this type of project because a task, a description of the task, estimated timeline, and date of completion can all be displayed on a single graph. This project will span the months of Sept 2015- June 2016, so a week will be the standard resolution for the charts. The schedules for quarters fall, winter (detailed winter schedule includes manufacturer tasks), and spring are in **Appendix E -- Schedule: Figure 44,**

(a)

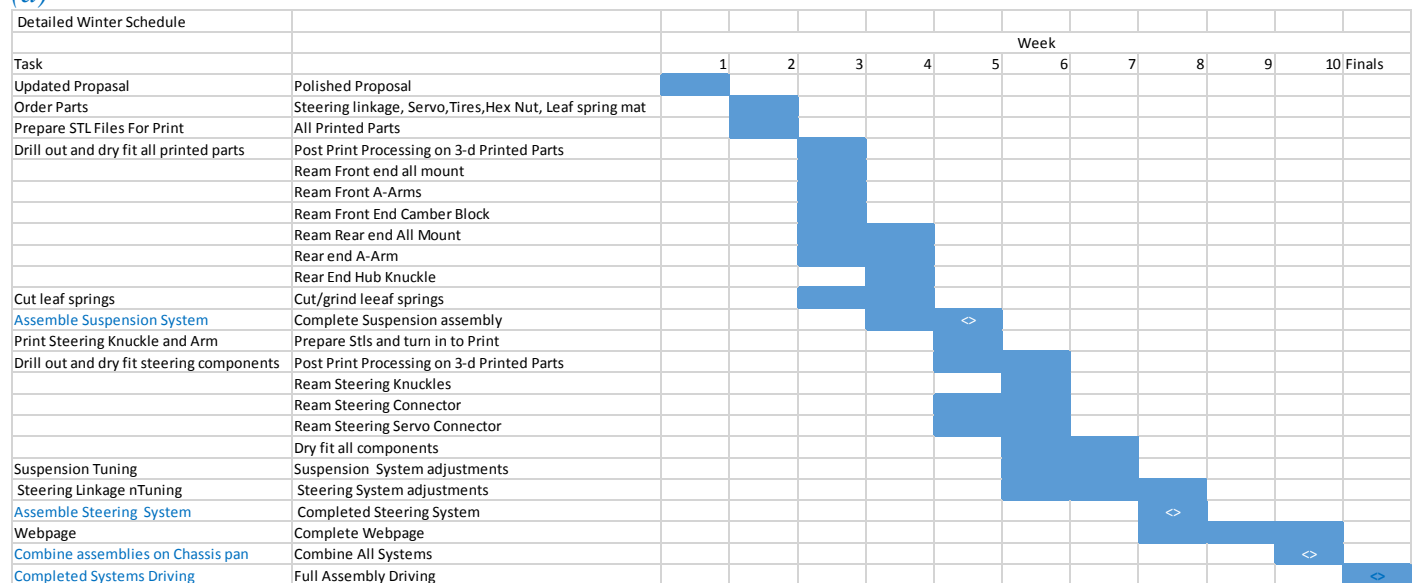

Figure 45, respectively. A schedule of the entire project is also in Figure 48.

### II. Milestones

Milestones are a good way of marking project progression. The publication of the website for this project and the approval of the subject were the first two milestones for this project. The next milestones are sections of the proposal and the final completed proposal. The next milestones are completed sub-assemblies for both the steering and

suspension systems, followed by a completed assembly. Once assembly is complete the final milestones are the completion itself and the completed turned in project (**Appendix Figure 47 Milestone Schedule**).

### III. Estimate Total Project Time

The current estimated project time is 215 hours (Figure 48 Full Year Schedule). This is a low approximation. As to this point in the project every task has taken longer than anticipated, and it is expected that the trend will continue. To mitigate the under approximations both predicted times and actual times to complete tasks will be recorded, and reflect changes in task completion predictions.

## 5G: Project Management

### I. Human Resources:

I am the primary human resource. My partner Jason Moore who is going to be producing and designing the drive train elements of the vehicle will also be a primary resource. Professor Pringle, Professor Beardsley, and Professor Johnson will be valuable resources for advice on design, analysis, and numerous other questions regarding the development of the project. Other human resources that are more related to the manufacture of the vehicle are Matt B. and Ted Bramble. Another valuable resource has been Nathan Wilhelm, who did this project last year. Nathan has been a valuable resource for advice and in donating his extra parts/drawings that will be used for this project.

### II. Physical Resources/Soft Resources:

The physical resources that will be used to complete this project include: the machine shop and rapid prototyping lab. The machine shop is equipped with numerous lathes, mills (horizontal and vertical), and CNC machines that will be used to fabricate and modify parts. The rapid prototyping lab has Computers with Solidworks, and CADD software for modeling parts and drawings, as well as fabricate parts via the 3-d printer.

## 6. CONCLUSION AND DISCUSSION

The project is feasible and will likely be successful. Possible issues that could arise and might stall the project are timeline. Sticking to the proposed schedule and not falling behind will be important to the project success. Another possible issue could be material procurement, some parts are expensive and the some of the materials (i.e. Blue temper 1023 carbon steel in .042" thickness) can be difficult to find in small non-industrial quantities. If roadblocks are avoided and everything stays on schedule then the project will definitely be successful.

### 6a: Design Evolution

Currently there are two major changes that have occurred to the design. The first is that the entire front end assembly will be mounted to a single part (all mount front and back). The all mount will attach to the chassis pan. The purpose of this design modification is to make the front end assembly modular so the whole front end steering and suspension sub-assembly can be taken on and off in a modular fashion.

The second large design change is in the suspension system. The original suspension was a piston and spring system, but is now a leaf spring system. The two major reasons for using a leaf springs system are that it decreases the amount of total parts to purchase and lowers the vehicles center of gravity.

The part that has gone through the most change in design iterations is the A-arms. Originally it was to be 3-d printed ABS, but after several different iterations and analysis it has been changed to part that will be machined from 1023 carbon steel stock. The different iterations are discussed more thoroughly in **II. Analysis of Suspension.**

### 6b: Project Risk analysis

The project is feasible and will likely be successful. Possible issues that could arise and might stall the project are timeline. Sticking to the proposed schedule and not falling behind will be important to the project success. Another possible issue could be material procurement, some parts are expensive and the some of the materials (i.e. Blue temper 1023 carbon steel in .042” thickness) can be difficult to find in small non-industrial quantities. If roadblocks are avoided and everything stays on schedule then the project will definitely be successful

### 6c. Successful

With discipline to stay on track and a little luck the project should prove very successful, and hopefully the vehicle will win some competitions and bring some glory to CWU MET department.

### 6d. Next phase.

The next phase of the project will be manufacturing and fitting the completed project physically together. Keys to success in the manufacturing phase will be staying on budget and on time schedule. Which includes getting started early on part manufacturing to avoid bottlenecks in trying to schedule time on a machine.

### 6e. Acknowledgements.

Many thanks are owed for the success of the completion of this proposal, to any and all who helped inspire or support this project thank you for your service. Thanks to last year's ASME student Baja competitor Nate Wilhelm for putting up with constant pestering and with providing, advice, parts, fasteners, drawings and pretty much whatever was asked of him. Especially large thanks to the CWU Machine Shop and Lab staff for their support and constant solutions to problems. And most of all the biggest thanks are owed to the CWU MET department advising staff, Professor Pringle, Professor Johnson, and Professor Beardsley, without their advice, direction, and inspiration it is mostly assured the project would have been a Death Star.



## Appendix

### Appendix A - Analyses

Michael Cox	MET 495a	11-30-15
-------------	----------	----------

Energy analysis of car dropping

Given:  
 $h = 2\text{ft}$   
 $m = 416$

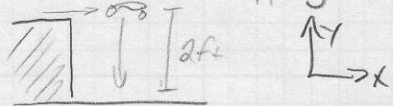

Find: Determine Force applied to springs of vehicle after a 2ft. drop.

Sol'n!

$P_e = k_e$

$$mgh = \frac{1}{2} kx^2 \Rightarrow k = \frac{2mgh}{x^2} \Rightarrow F = kx$$

$$= \left( \frac{2mgh}{x^2} \right) x$$

$$F = \frac{2mgh}{x}$$

$$F = \frac{2(416)(32.2 \frac{\text{ft}}{\text{sec}^2})(2\text{ft})}{\left( \frac{15\text{ft}}{12} \right)}$$

$$F = 4121.6 \left( \frac{1}{37.5} \right) = 128.8 \text{ lbf}$$

↑  
for  
Pounds  
into force

$F = 128.8 \text{ lbf}$

On a Flat drop all 130 lbf would be distributed across, all 4 tires, for the purpose of my analysis I will assume that 1 end of car comes down before the other, so force will be divided by 2 (on for each side of front/back end)

Figure 8 Energy of car dropping and force applied.



Michael Cox MET 495a 11-30-15

Given: Figure (Leaf spring assembly)

$$F = \frac{128.8 \text{ lbf}}{2} = 64.4 \text{ lbf}$$

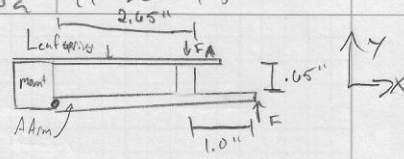

Find: Determine Force Applied to A  
(Find  $F_A$ )

Sol'n:

FBD

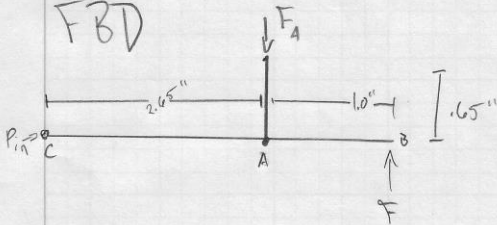

$$(+\uparrow \sum M_C = 0: -F_A (2.65'') + F (3.65'')$$

$$-F_A = \frac{F (3.65'')}{2.65''} = \frac{64.4 \text{ lbf} (3.65'')}{2.65''}$$

$$F_A = 88.702 \text{ lbf}$$

Figure 9 Statics for force applied to leaf spring.

Michael Cox MET 495A 11-30

Given:

$F = 88.702$        $L = 2.65''$       Thickness = .025

Spring Steel (AISI 1095 OQT)       $\Delta x = 1.5''$

$E = 30,000 \text{ ksi}$

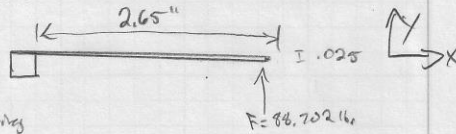

Find: Determine dimensions of leaf spring

So that when  $F$  is applied there is  $1.5''$  of travel ( $\Delta x$ ).

Sol'n:

$$I_x = \frac{1}{12} b h^3$$

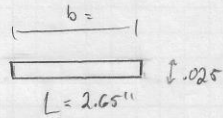

$$y_{\max} = \frac{-PL^3}{3EI}$$

$$\Delta x = \frac{PL^3}{3EI} \Rightarrow 1.5'' = \frac{(88.7 \text{ lb}_f)(2.65'')^3}{3(29,000,000)(\frac{1}{12} b (.025^3))}$$

$b = 9.17''$  (unacceptable)  
try using thicker gage steel  
Input Equation into Excel for opt.

\* Using .042" thick stock  $b = 1.980''$

Spring dimensions =  $2.65 \times 1.98 \times .042''$

Figure 10 Leaf Spring Dimensions

Michael Cox

MET 495

11-30-15

### Fastener analysis

Given:

#6-32 x 1/2" Phillips Drive Pin Head Machine Screw. (Fastenal.com)

$\phi = .1380$  Carbon Steel (Low carbon Steel AISI cold drawn Material.com)

$S_y = 41,3 \text{ ksi}$

$$F = 64.4 \text{ lbs}$$

\* <sup>assumption</sup> Shock tires and springs fail to absorb force \*

Find: is a #6 Machine screw going to shear

Sol'n:

$$\uparrow \sum F_x = 0: F_A = F$$

$$F_A = 64.4 \text{ lbs}$$

$$S = \frac{V}{A} = \frac{64.4 \text{ lbs}}{A}$$

$$A = \pi r^2 = \pi (.069)^2 = .014957$$

$$(r = \frac{.1380}{2} = .069 \text{ in})$$

$$= \frac{64.4 \text{ lbs}}{.014957}$$

$$= 4278.89 \text{ lb/in}^2$$

$$\frac{41.3 \times 10^3}{4278.89} = 9.65 = N$$

almost a safety factor of 10

So no worries in the fastener dept.

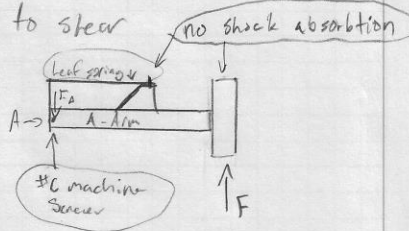
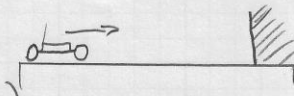

Figure 11 Fastener shear analysis.

Michael Cox ME 495c 12-2-15

Force analysis Vehicle @ 20mph.  $m = 416$   $V = 20$  MPH

Given: 416 lb Vehicle traveling 20 mph   
Strikes an object (.1 seconds to stop)

Find: Determine Force of impact.

Sol'n:

$$F = m a \quad \left(\frac{20 \text{ m}}{\text{hour}}\right) \left(\frac{5280 \text{ ft}}{1 \text{ mile}}\right) \left(\frac{1 \text{ hr}}{3600 \text{ sec}}\right) = 29.33 \frac{\text{ft}}{\text{sec}}$$

$$F = m \left(\frac{dv}{dt}\right)$$

$$F = (416 \text{ lb}_m) \left(\frac{29.33 \frac{\text{ft}}{\text{sec}}}{.1 \text{ sec}}\right) = 1173.2 \text{ lb}_f$$

1172.2 lb<sub>f</sub> @ impact



$$F \times .5 = 1172.2 \times .5 = 586.1$$

Figure 12 Impact Force of vehicle @ 20MPH.

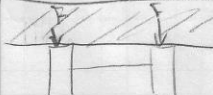

Michael Cox MET 495<sub>2</sub>

A-Arm analysis:

Given: Material Properties of printed ABS.

(Specs provided by MET 418 Lab. 04 "Lever Arm Lab") STRATASYS  
ABS

$S_u = 3200$  psi (Tensile Strength)

Fracture Strength: 6000 psi (or modulus of rupture) < Yield

Bending Modulus: 266 ksi (Flexural modulus)

Elastic Modulus: 236 ksi (Youngs or tensile modulus)

Percent elongation: 30%

(Percent Elongation provided by MAT.web.com Extruded A.B.S Average values)

Tensile Modulus  
2.3 GPa

Density: 1.05 g/cc = .03743366 lb/in<sup>3</sup>

Part: A-ARM 1.01

Force of impact 500 lbs

Find: Determine if ABS arms will yield at given the impact force.

Sol: Use FEA via solid works Simulation express analysis wizard.

Input appropriate values from above into material property of analysis wizard.

Results: lowest Safety factor = .05 (Fail)

Fail Yield at Both ends of A-Arm

Max Von Mises = 106,500 psi > 6000

(Full detail of results in appendix)

Part needs to be re modeled

+ Add  to Frame to give the A-arm an I-Beam  
in cross section

Then re-run simulation →

Flexural  
modulus

Figure 13 First Step in FEA of A-Arm 1.0

→ continued analysis of A-Arm

A-Arm 1.02 Analysis

Fail: Yielded only at one end this time but still yielded.

Min Safety Factor: .07      Max Von Mises Stress: 57 Ksi  
Max displacement: .0097"

\* Total redesign of part, part needs to be more triangular with a wider base

Figure 14 FEA of A-Arm 1.02 part 2

Michael Cox MET 495a

A-Arm analysis → A-Arm 2.0 ABS (Printed)

Given:

Printed ABS Specs (Matweb and MET 419 provided)

$S_u = 3200 \text{ ksi}$

Fracture Strength (modulus of rupture) = 6000 Psi

Elastic Modulus: 236 ksi

Density: .03793366 lb/in<sup>3</sup>

Force: 586 lbf

(Dimensions in Appendix under drawings A-Arm 2.0 ABS)

Find: Determine if part will fail.

Sol'n:

Use FEA via Solidworks  
(complicated geometry)

Results: Fail

Yielded at rear pin, and near fail at front outside pin.

Max Von Mises = 11.815 ksi

Max displacement = .09842"

Lowest Factor of Safety: .05 Fail

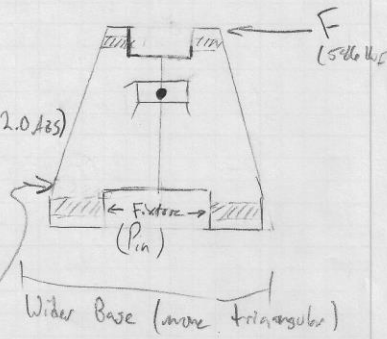

(Redesign

New Material

Steel + (Reduce thickness  
to .25")

Figure 15 FEA A-arm Part 3 (2.0 ABS)

Michael Cox MET 495  
 A-Arm analysis → A-Arm 2.02 Steel  
 Given: Mat specs of low carbon steel (Mat Web)  
 1023 carbon steel  
 $S_y = 41 \text{ ksi}$     $S_u = 61.641 \text{ ksi}$     $E_{mod} = 29732735 \text{ Psi}$   
 Density: .283888  
 $F = 586 \text{ lbf}$   
 Find: Use FEA to determine if part will  
 Fail  
 Sol'n:  
     Success  
 No Yield  
 Max Von missis 12.205 Psi  
 Safety Factor (lowest) = 3.3 \*  
     Success

Figure 16 Final FEA of A-Arm 2.0 STEEL



Michael Cox MET 495a

Steering Geometry: Steering angle

Given Geometry →

Find: Determine  
Theta (steering angle)

Sol'n:

$$\phi = \tan^{-1} \left( \frac{1''}{3.65'' + 1'' + .25''} \right)$$
$$\phi = 73.3^\circ$$

Adjust geometry of steering arm

$$68.5^\circ - 73.3^\circ = -4.8^\circ$$

Adjustment of  $4.8^\circ$  to steering arm

Difference between inside and outside lanes at a 50" turn radius,

$$.25 \times 2 + 1 \times 2 + 3.65 \times 2 = 9.8'' \quad 50 - 9.8'' = 40.2''$$

Use 50" radius circle and 40.2"

radius circle to determine wheel turn angle,

★ Sol. use solid works for geometry  
(very accurate no mistakes)

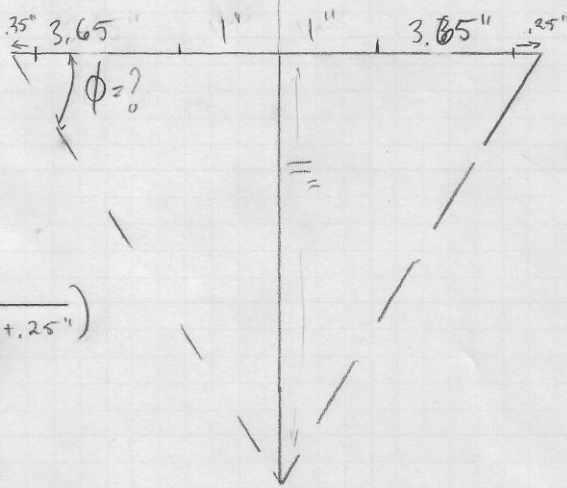
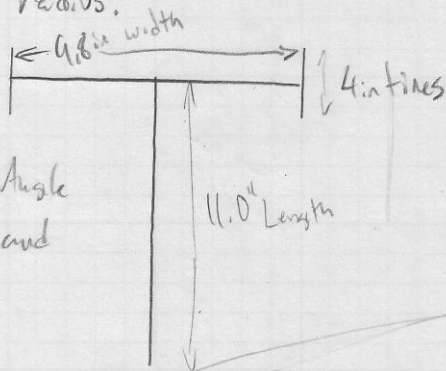

Figure 17 Steering Knuckle Modification Geometry

Michael Cox MET 495a

Given: A 50" turn radius.

Figure →



Find: Determine Ackerman Angle  
(angular difference between inside and  
outside wheels)

Sol'n:

Use slidworks to  
Model and measure  
angular change  
See Appendix  
For ackerman  
angles

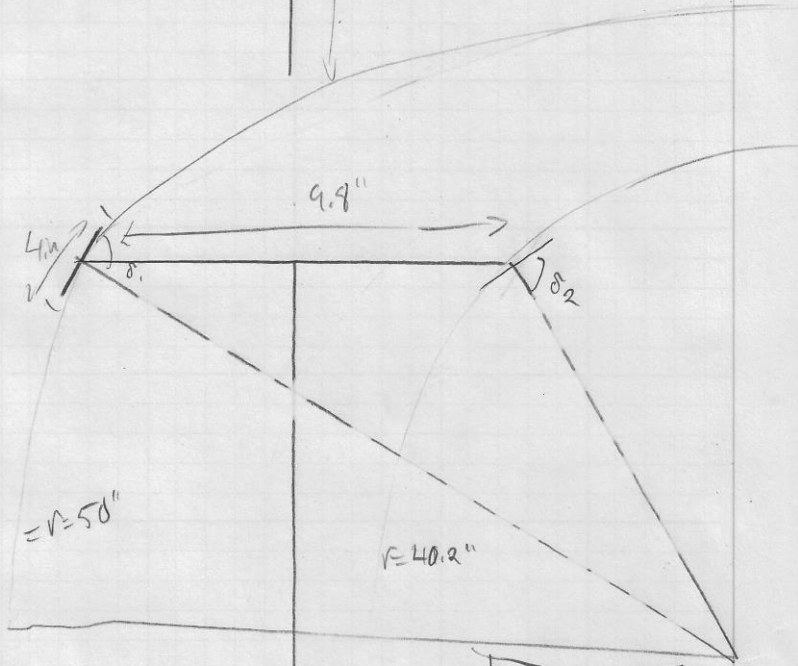

1st @ 50" radius turn angular difference = .6°

2nd @ 25" radius turn angular difference = 3°

Figure 18 Ackerman Angle Part 1

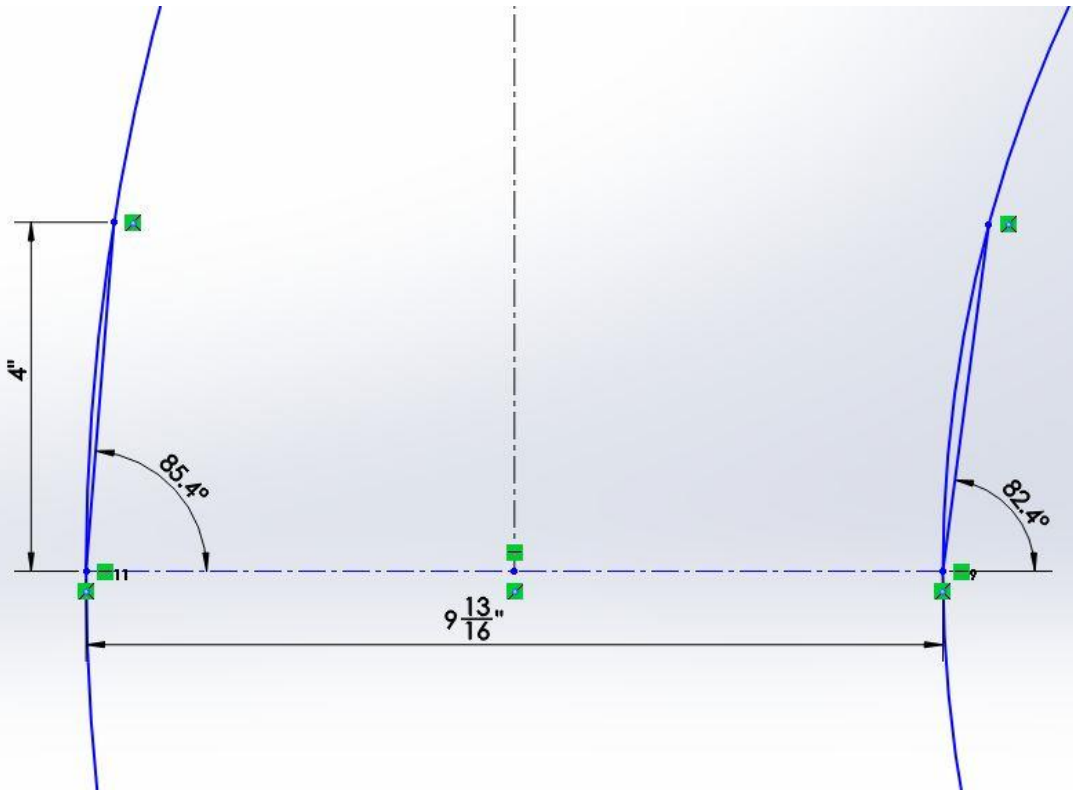

Figure 19 Ackerman Angle Part 2

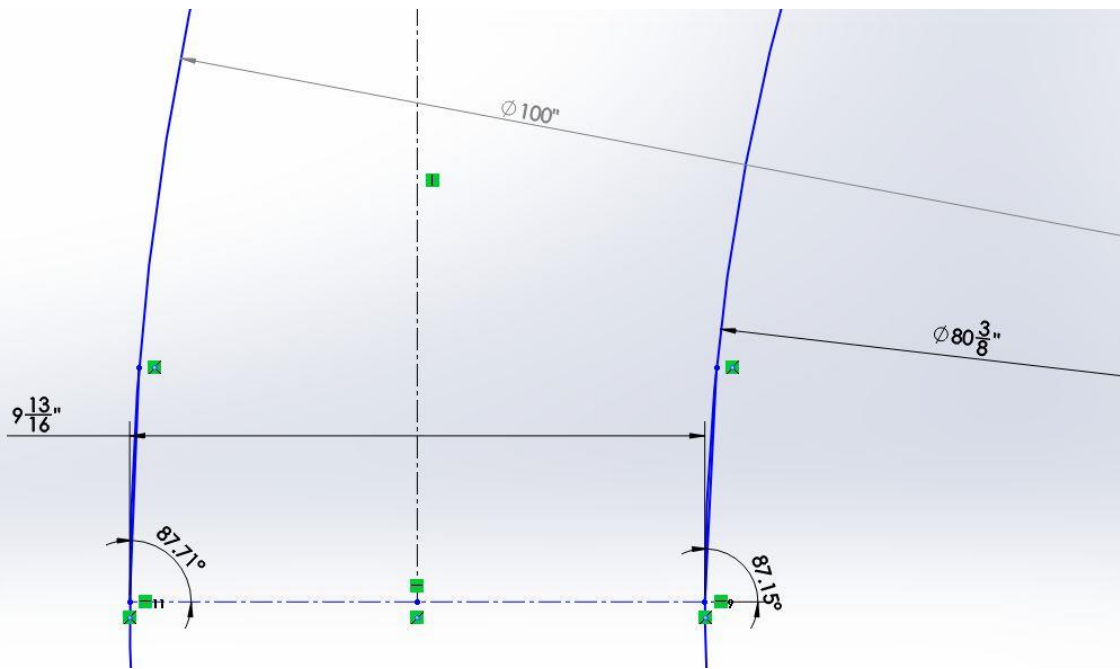

Figure 20 Ackerman Angle Part 3

Michael Cox	MET	495	10-28-15	1/1
-------------	-----	-----	----------	-----

Energy Analysis for a 4lb can dropping 2ft.

Given:  $M = 4 \text{ lb}_m$   $H = 2 \text{ ft}$

Find: Energy @ impact

Sol'n:

PE = KE  
 $mgz = kv$

~~$(4 \text{ lb}_m) (32.2 \frac{\text{ft}}{\text{sec}^2}) (2 \text{ ft})$~~  = make things easy convert to metric

$(m) (\frac{\text{ft}}{\text{sec}^2}) (\text{ft}) = m \cdot \frac{\text{ft}}{\text{sec}^2}$

$(1.8143 \text{ kg}) (\frac{9.81 \text{ m}}{\text{sec}^2}) (.6096)$

$= 10.8498 (\frac{\text{kg} \cdot \text{m}}{\text{sec}^2}) (\text{m}) = 10.84 \text{ N} \cdot \text{m}$

$\frac{2 \text{ ft}}{\text{sec}^2} = \frac{16 \text{ ft}}{\text{ft}}$

$H_g = 2.2046 \text{ lb}_m$

$\frac{1 \text{ ft}}{\text{sec}^2} = .3048 \frac{\text{m}}{\text{sec}^2}$

$1 \text{ ft} = .3048 \text{ m}$

$(1 \text{ Newton}) = \frac{1 \text{ kg} \cdot \text{m}}{\text{sec}^2}$

$1 \text{ lb} = 1000 \text{ N} \cdot \text{m}$

$1 \text{ in} = 39.370 \text{ in}$

$(4 \text{ lb}_m) (\frac{1 \text{ kg}}{2.2046}) = 1.8143 \text{ kg}$

$(32.2 \frac{\text{ft}}{\text{sec}^2}) (\frac{.3048}{1 \frac{\text{ft}}{\text{sec}^2}}) = 9.81 \frac{\text{m}}{\text{sec}^2}$

$(2 \text{ ft}) (\frac{.3048}{1 \text{ ft}}) = .6096$

$10.84 \text{ N} \cdot \text{m} \times \frac{1 \text{ J}}{1 \text{ N} \cdot \text{m}} = 10.84 \text{ J}$

Work Done By A 2inch Linear Spring

$W_{\text{spring}} = \frac{1}{2} k (x_1^2 - x_2^2)$

Given: Energy of Impact = 10.84 J

$\Delta x = 2 \text{ in} (\frac{1 \text{ in}}{39.370}) = .0508 \text{ m}$

Find: k

$\frac{(10.8498 \text{ J}) 2}{.0508} = k = 427.157 \frac{\text{J}}{\text{m}} = 427.157 \frac{\text{N}}{\text{m}}$

For 2inch Spring Need A  $k = 427.157 \frac{\text{N}}{\text{m}}$

Figure 21: Analysis of energy developed from a drop from a height of 2ft. and the calculations for k factor of a 2 inch spring. (Unused design iteration)



Michael Cox 10/18/15

# Steering Linkage

## Ackerman Angle

$\delta_o$  = Outer steering angle     $\delta_i$  = inner steering angle

R = turn Radius

L = wheel base

t = distance between tires

Simple  $\delta = \frac{L}{R}$

(High Speed)  
 $\delta = \frac{L}{R} + \alpha_f - \alpha_r$

Given: L = 12"  
R = 45"  
t = 4.5"

$$\alpha_f = \frac{W_f \cdot V^2}{C_{\alpha f} \cdot g \cdot R}$$

$$\alpha_r = \frac{W_r \cdot V^2}{C_{\alpha r} \cdot g \cdot R}$$

$W_f$  = Tire weight  
 $C_{\alpha}$  = cornering stiffness  
 $g$  = gravity  
 $V$  = vehicle velocity

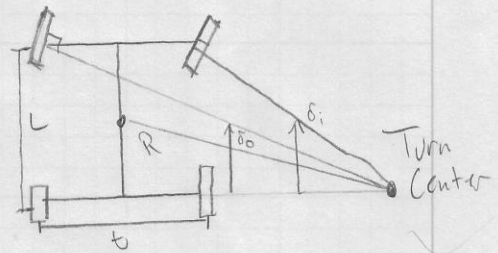

Find: Low Speed  
Ackerman angle

$\delta = 12/45$   
 $\delta = .2666?$

$$C_{\alpha} = \frac{\Delta F_y \text{ Lateral force}}{\Delta \alpha \text{ tire angle}}$$

Figure 22: First attempt at determining the Ackerman Angle for a 45"(r) turn. (Unused design iteration)

# LEAF Spring Blocks MEC MET 495A

Given: →

Determine:  
Force applied at C

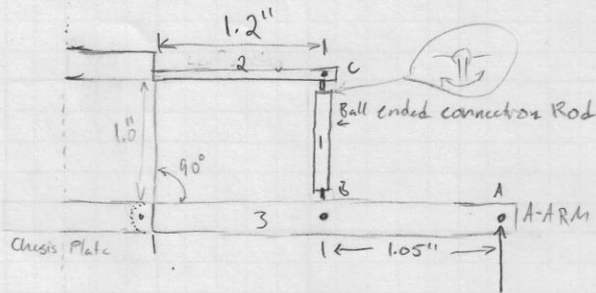

$$F = 18 N = \frac{18 N \times 1 \text{ lb}_f}{4.448 N} = 4.0416$$

Sol:

F.B.D.

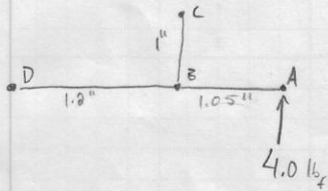

Equations of Equ.

$$\sum M_B = 0; -F_B(1.2") + 4.016(2.25) = 0$$

$$F_B = \frac{4.016(2.25)"}{1.2"} = 7.5 \text{ lb}_f$$

$$F_B = F_C = 7.5 \text{ lb}_f$$

Option A:

Replace Member 1 with vertical travel spring

Determine: k-Factor of springs with 1" of travel. Expect spring to do

Sol'n: Work of spring =  $\frac{1}{2} k(dx) \Rightarrow$  Work =  $F \times d$   $F = 7.5 \text{ lb}_f$   $d = 2 \text{ ft}$   
 Force  $\times$  distance  
 $15 = .5 (k) (1/2")$   
 $15 = 15 \text{ lb}_f \cdot \text{ft}$

$$k = \frac{15 \text{ lb}_f \cdot \text{ft}}{.5 \times (1/2) \text{ ft}} = 360 \frac{\text{lb}_f \cdot \text{ft}}{\text{ft}}$$

Option B: keep Rod use leaf spring for member 2

Given: I for leaf spring =  $I_x = \frac{1}{12} b h^3 = \frac{1}{12} (1") (\frac{1}{8}")^3 = .00016276 \text{ in}^4$

Find: Determine exceed modulus E for a 1" deflection at C

Sol'n:  $y_c = y_{max} = \frac{-PL^3}{3EI} \Rightarrow 1" = \frac{-(7.5)(1.2")^3}{(3)(E)(.00016276 \text{ in}^4)}$

Spring steel  
E = 30,500 ksi

Erwin

$$E = 26542.14 \text{ lb/in}^2 = 26.5 \text{ ksi}$$

Figure 23 First attempt at leaf spring statics (unused design iteration)

Michael Cox	MET	495	10-28-15	1/1
-------------	-----	-----	----------	-----

Energy Analysis for a 4lb car dropping 2ft.

Given:  $M = 4 \text{ lb}_m$   $H = 2 \text{ ft}$

Find: Energy @ impact

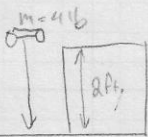

Sol'n:

PE = KE  
 $m g z = k e$

~~$(4 \text{ lb}_m) (32.2 \frac{\text{ft}}{\text{sec}^2}) (2 \text{ ft})$~~  = make things easy convert to metric

$(m) (\frac{\text{ft}}{\text{sec}^2}) (\text{ft}) = m \cdot \frac{\text{ft}^2}{\text{sec}^2}$        $(4 \text{ lb}_m) (\frac{1 \text{ kg}}{2.2046}) = 1.8143 \text{ kg}$

$(\frac{32.2 \text{ ft}}{\text{sec}^2}) (\frac{.3048}{1 \text{ ft}}) = 9.81 \text{ m/sec}^2$

$(1.8143 \text{ kg}) (\frac{9.81 \text{ m}}{\text{sec}^2}) (.6096) = 10.8498 (\frac{\text{kg} \cdot \text{m}}{\text{sec}^2}) = 10.84 \text{ N} \cdot \text{m}$

$(2 \text{ ft}) (\frac{.3048}{1 \text{ ft}}) = .6096$

$\frac{1 \text{ ft}}{\text{sec}^2} = .3048 \frac{\text{m}}{\text{sec}^2}$

$1 \text{ ft} = .3048 \text{ m}$

$1 \text{ Newton} = \frac{\text{kg} \cdot \text{m}}{\text{sec}^2}$

$1 \text{ kJ} = 1000 \text{ N} \cdot \text{m}$

$1 \text{ m} = 39.370 \text{ in}$

$\frac{10.84 \text{ N} \cdot \text{m}}{10 \text{ N} \cdot \text{m}} = 10.84 \text{ J}$

Work Done By A Linear Spring

$W_{\text{spring}} = \frac{1}{2} k (x_1^2 - x_2^2)$

Given: Energy if impact = 10.84 J

$\Delta x = 2 \text{ in} (\frac{1 \text{ m}}{39.370}) = .0508 \text{ m}$

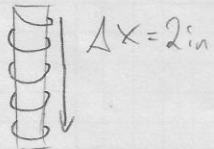

Find: k

$\frac{(10.8498 \text{ J}) 2}{.0508} = k = 427.157 \frac{\text{J}}{\text{m}} = 427.157 \frac{\text{N}}{\text{m}}$

For Linear Spring Need A  $k = 427.157 \frac{\text{N}}{\text{m}}$

Figure 24 K value of a linear Spring (unused design iteration)



Michael Cox

MET 495A

11-7-15

Given! Spring Steel  $E = 29,000$  ksi (MATWeb oil quenched and tempered)  
AISI 1095

$$L = 4.25''$$

$$\text{Thickness} = .015''$$

$$\Delta x = 1.5''$$

$$F = 4 \text{ lb}_f$$

A leaf spring experiences a force of 4 lb.

Find: Determine geometry of leaf spring so that it will travel 1.5'' when subjected to a 4 lb<sub>f</sub>.

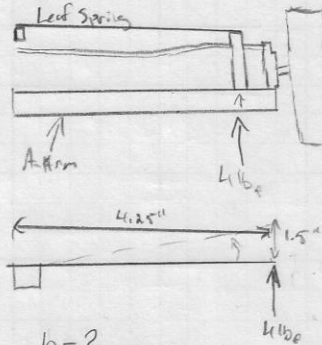

Sol'n!

moment of inertia for rectangular beam.

$$I_x = \frac{1}{12} b h^3$$

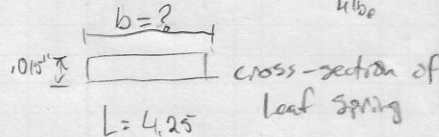

Use beam analysis appendix A(4-2 Mech design (Mat))

$$y_{\max} = \frac{-PL^3}{3EI}$$

$$P = 4 \text{ lb} \quad L = 4.25''$$

$$E = 29000 \text{ ksi} \quad y_{\max} = 1.5''$$

$$1.5'' = \frac{-(4 \text{ lb}_f)(4.25'')^3}{3(29,000 \text{ ksi})\left(\frac{1}{12}(b)(.015'')^3\right)}$$

$$b = 8.5'' ?$$

?

Metric

$$.05081 \text{ m} = \frac{-(14 \text{ N})(.10795 \text{ m})^3}{3(200 \times 10^9 \text{ Pa})\left(\frac{1}{12}(b)(.000381 \text{ m})^3\right)}$$

$$b = .2149 \text{ m}$$

$$= 8.5''$$

Need stiffer material

\* Equation placed into excel for optimization \*

\* Using a thickness of .025'' Spring base = 1.80'' \*

Leaf Spring dimensions =	Length	width	thickness
	4.25''	1.80''	.025''

Figure 25 First attempt at leaf spring dimensions (unused design iteration)



# Appendix B - Sketches and Drawings

## SKETCHES

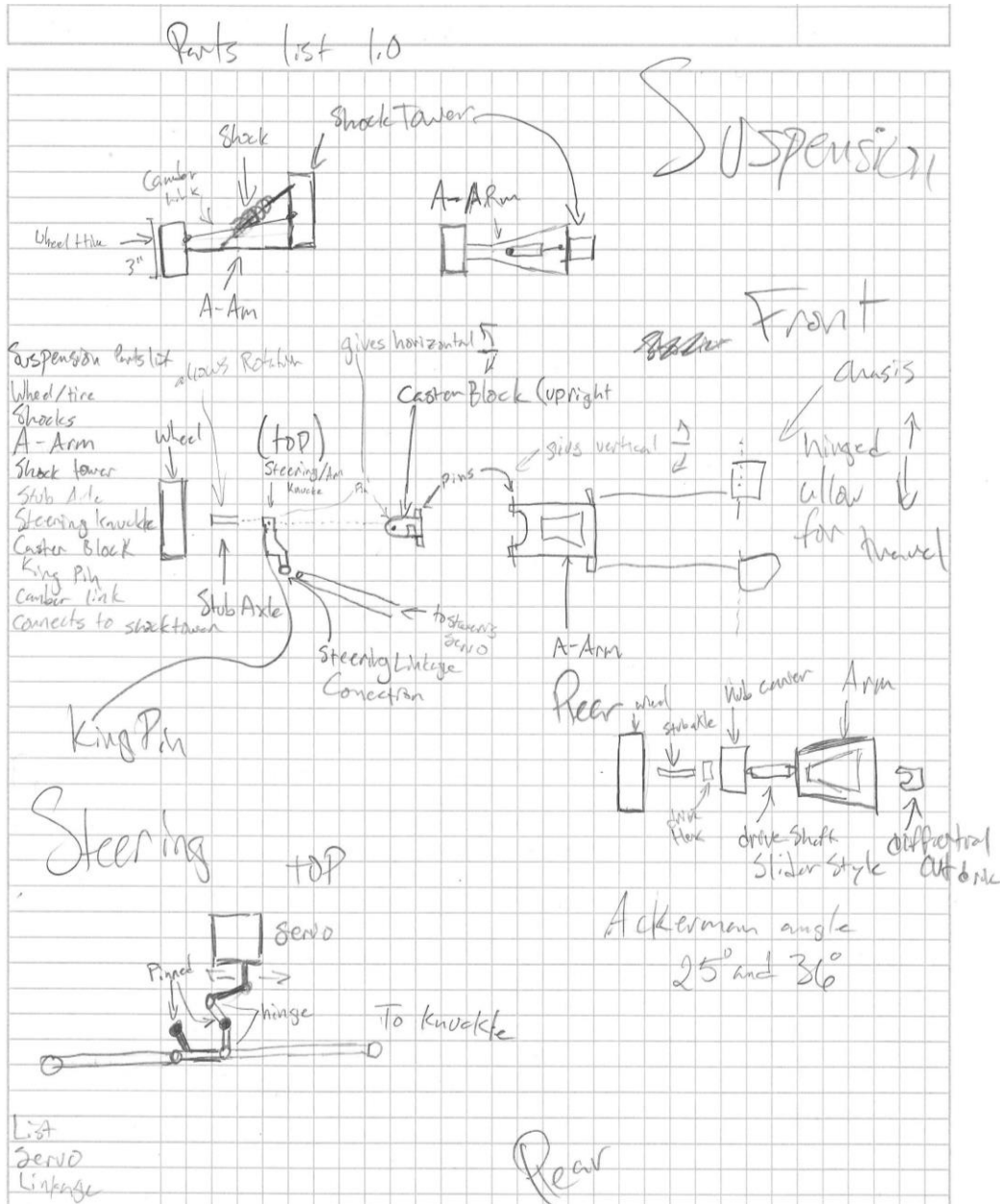
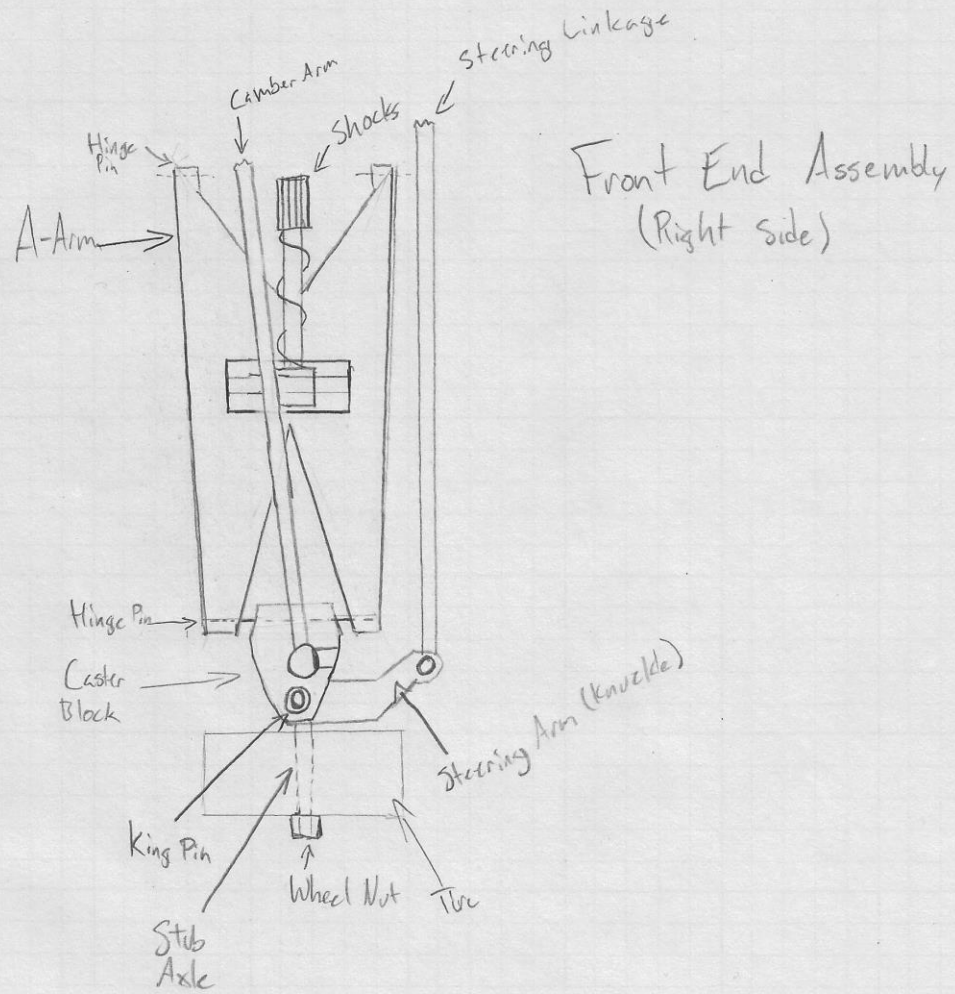

Figure 26: Parts list and preliminary assembly sketch.

Michael Cox

10/16/15

Figure A



Front End Assembly  
(Right side)

Figure 27 Initial Sketch of Assembly (unused design iteration)

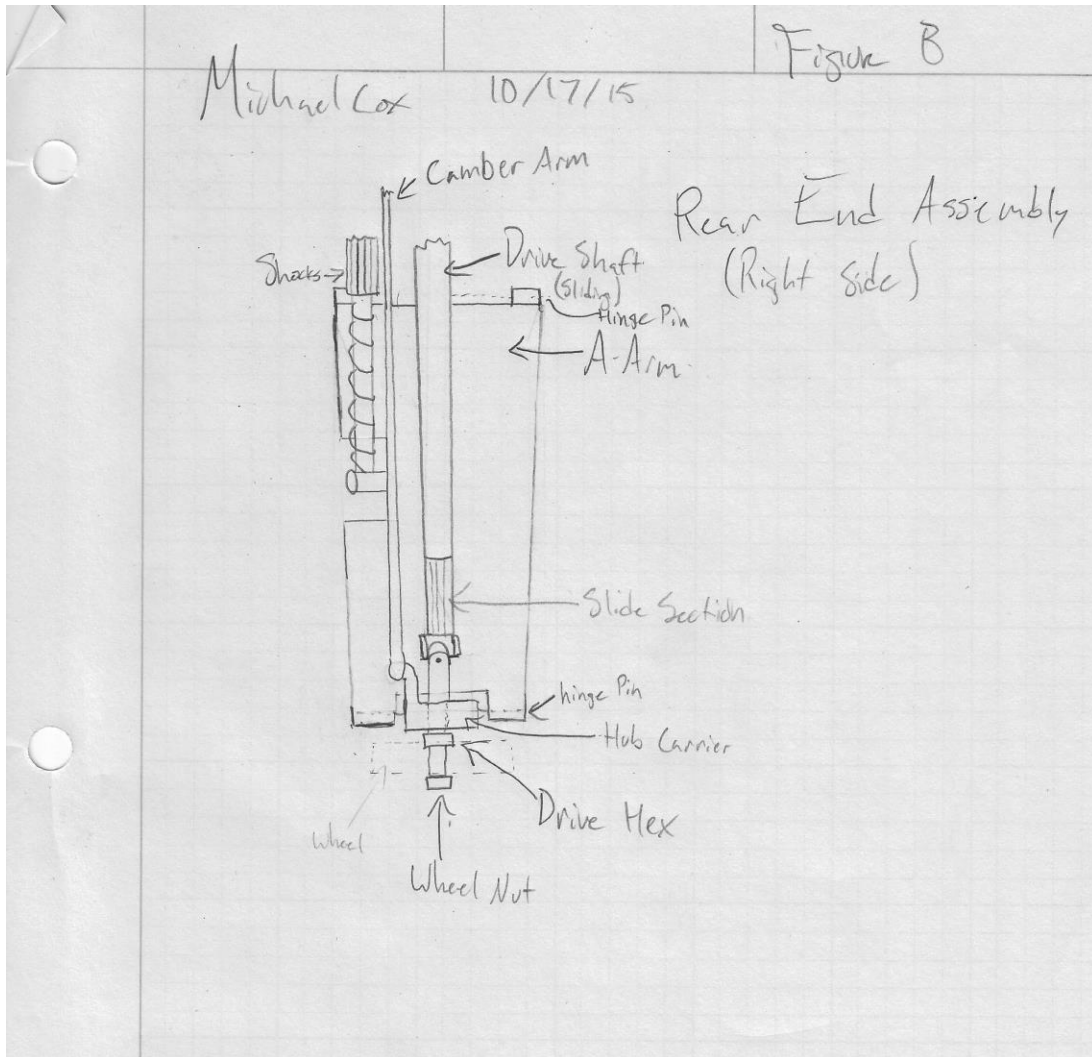

Figure 28 Initial Design of Rear Assembly (unused design iteration)

# DRAWINGS

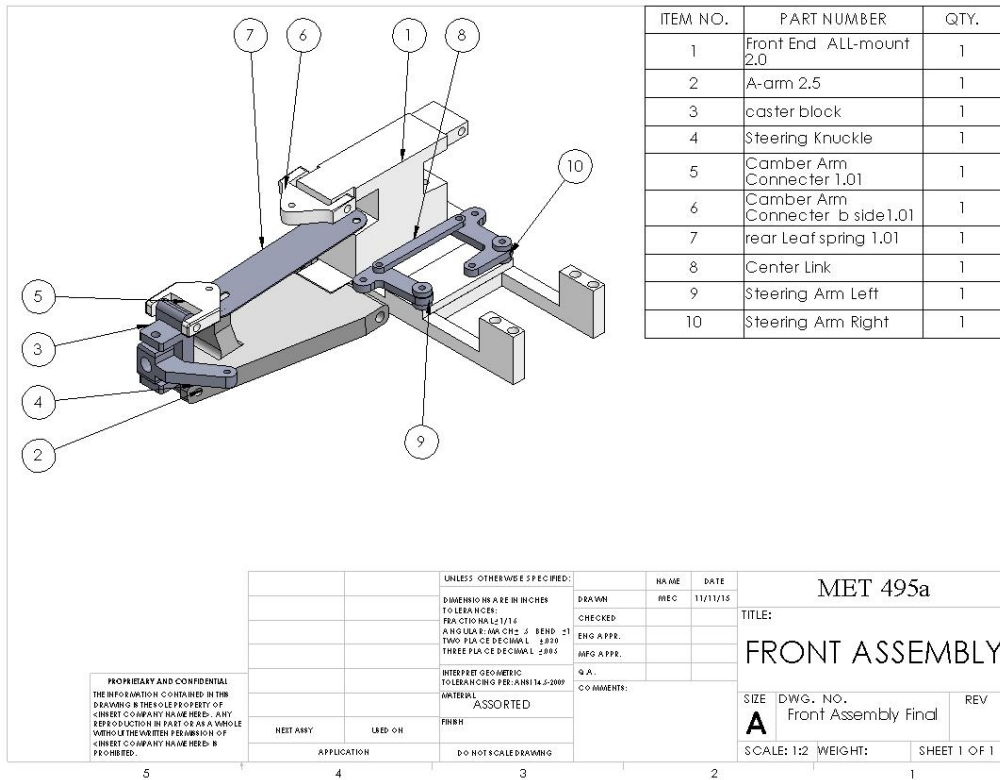

Figure 29 FRONT ASSEMBLY

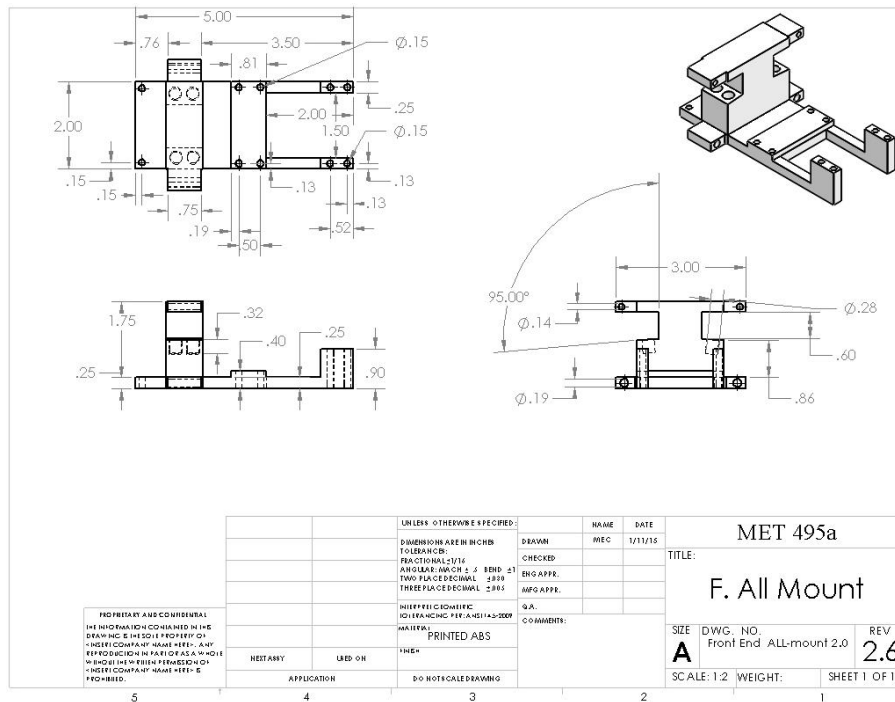

Figure 30 FRONT END ALL-MOUNT

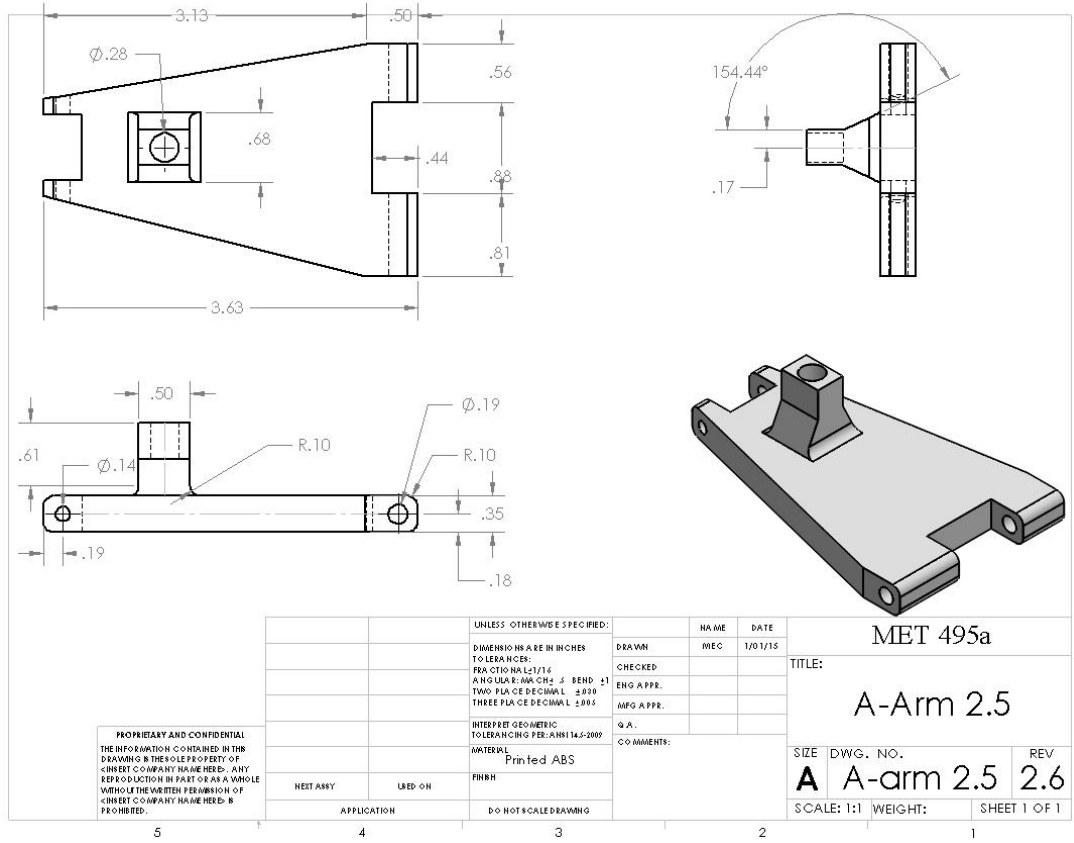

Figure 31 A-ARM (FINAL REVISION)

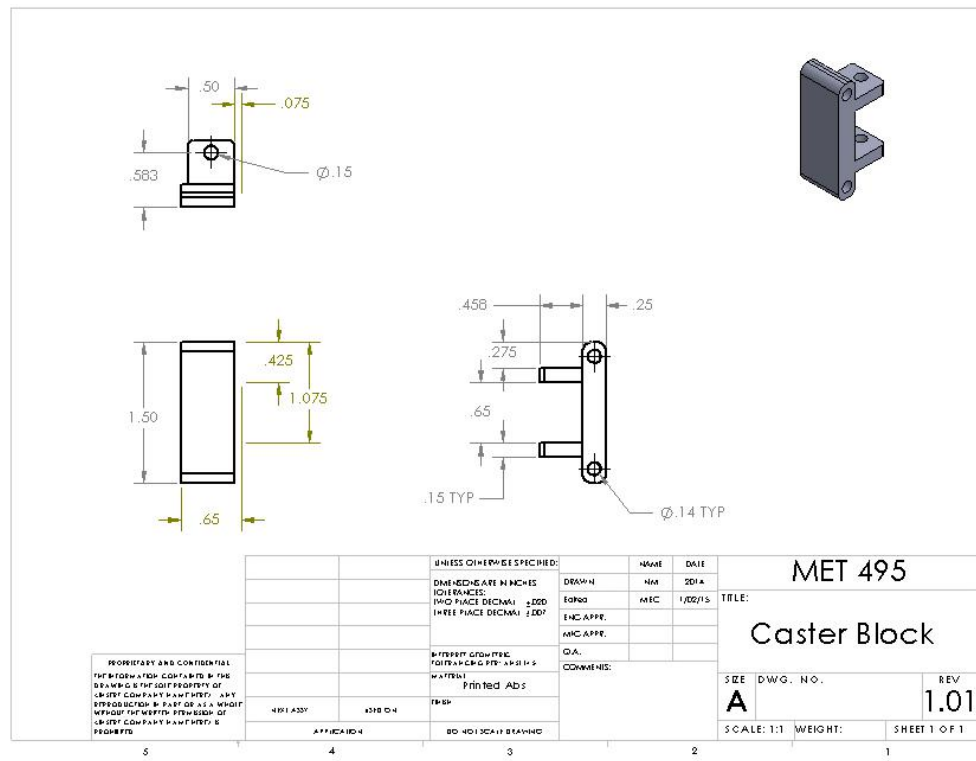

Figure 32 CASTER BLOCK



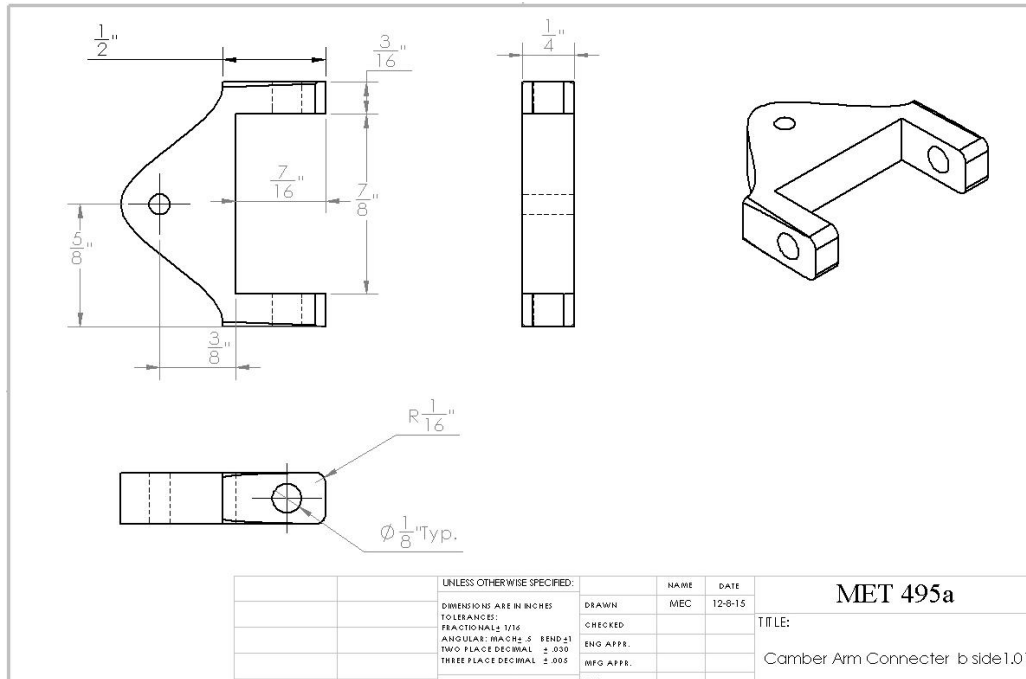

Figure 33 CAMBER ARM CONNECTOR B SIDE

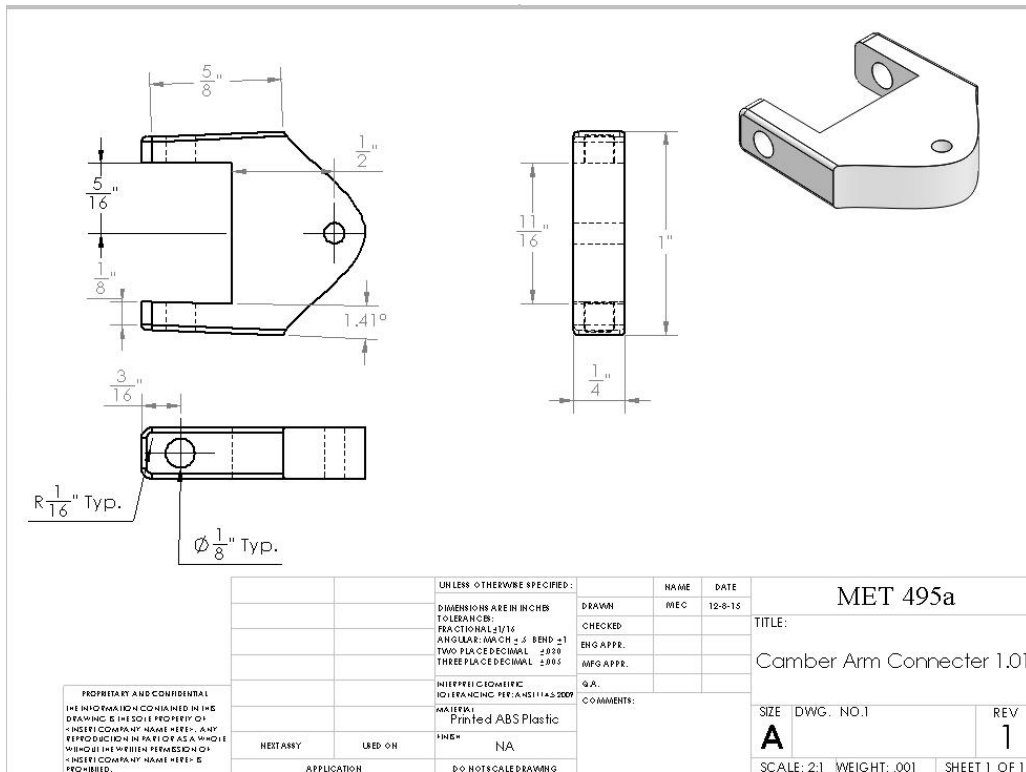

Figure 34 CAMBER ARM CONNECTOR C SIDE

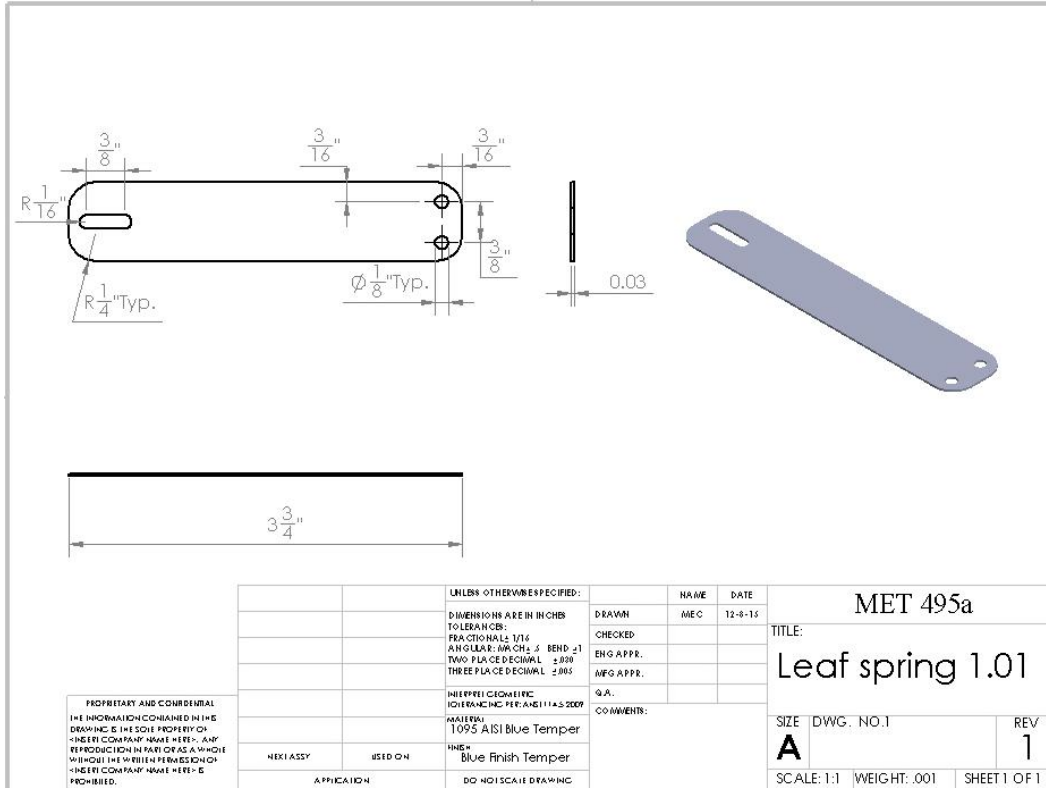

Figure 35 LEAF SPRING FRONT AND REAR

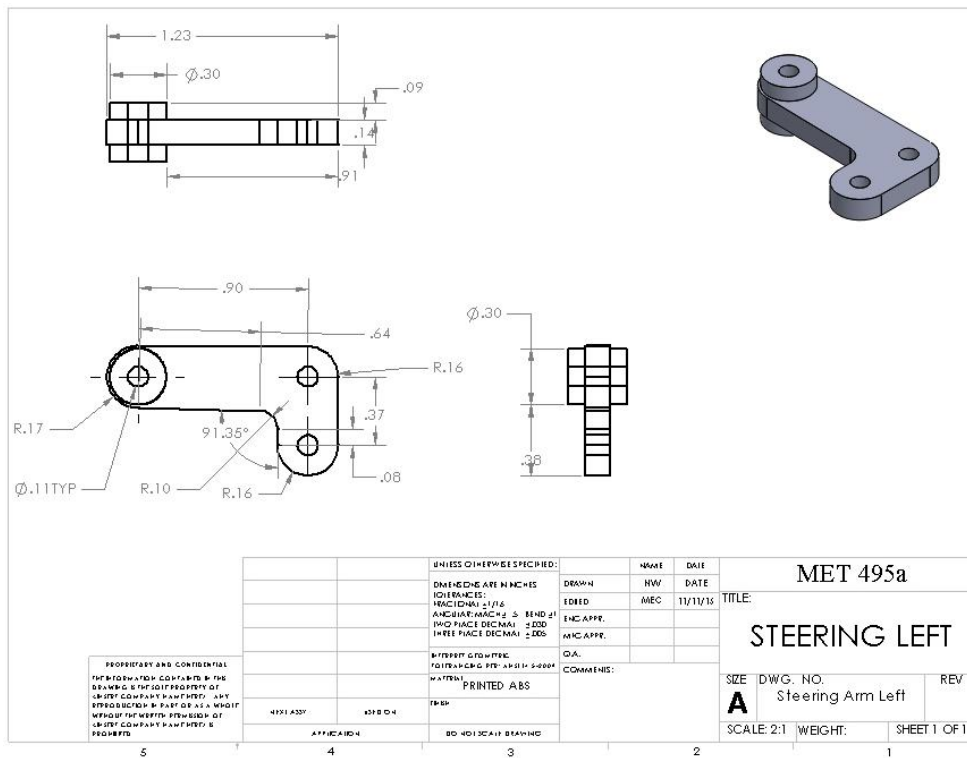

Figure 36 STEERING KNUCKLE LEFT

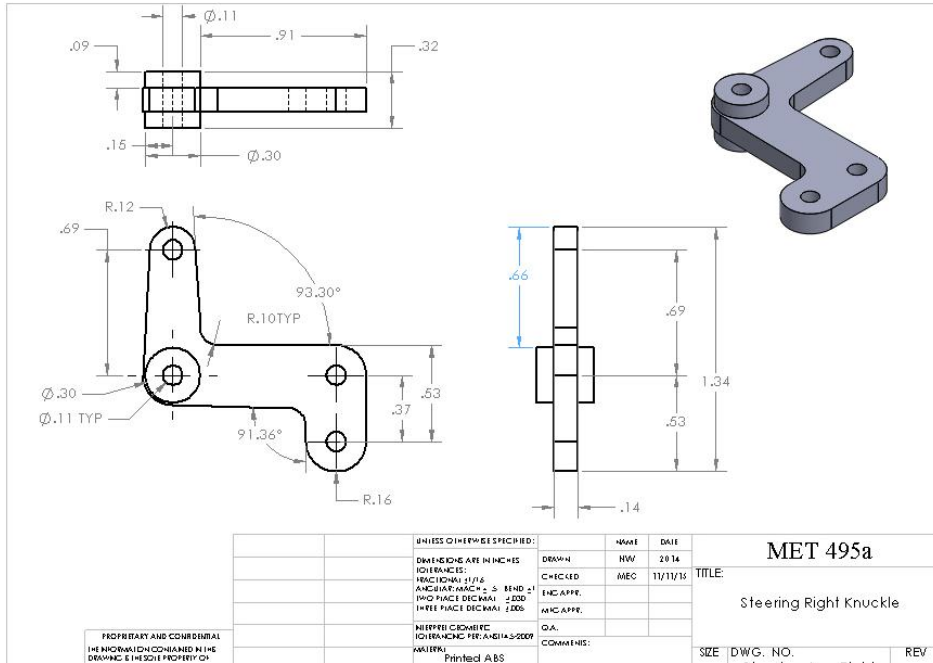

Figure 37 STEERING KNUCKLE RIGHT

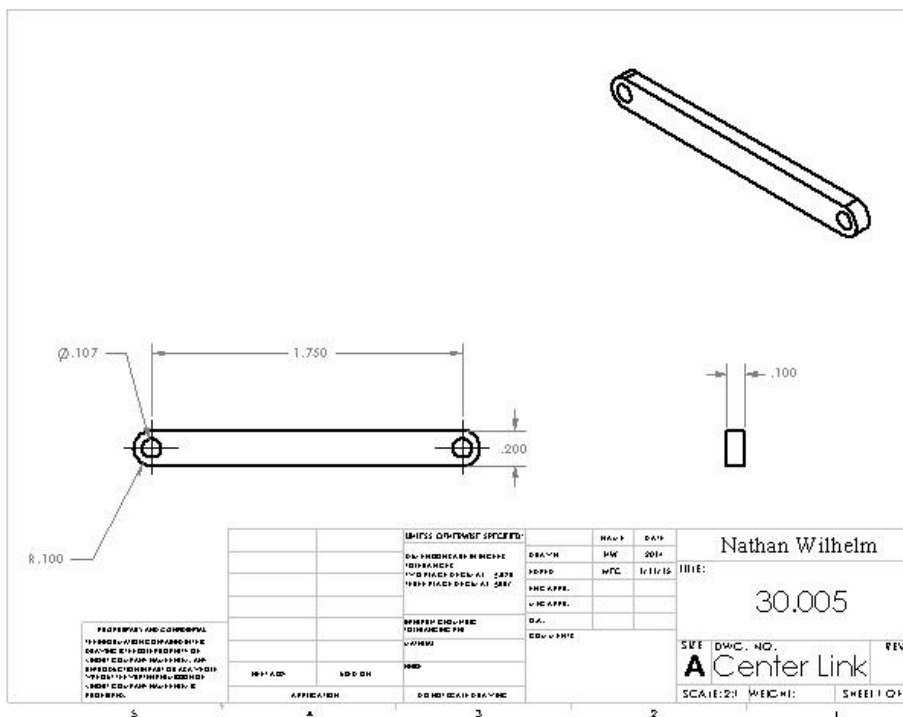

Figure 38 CENTER LINK



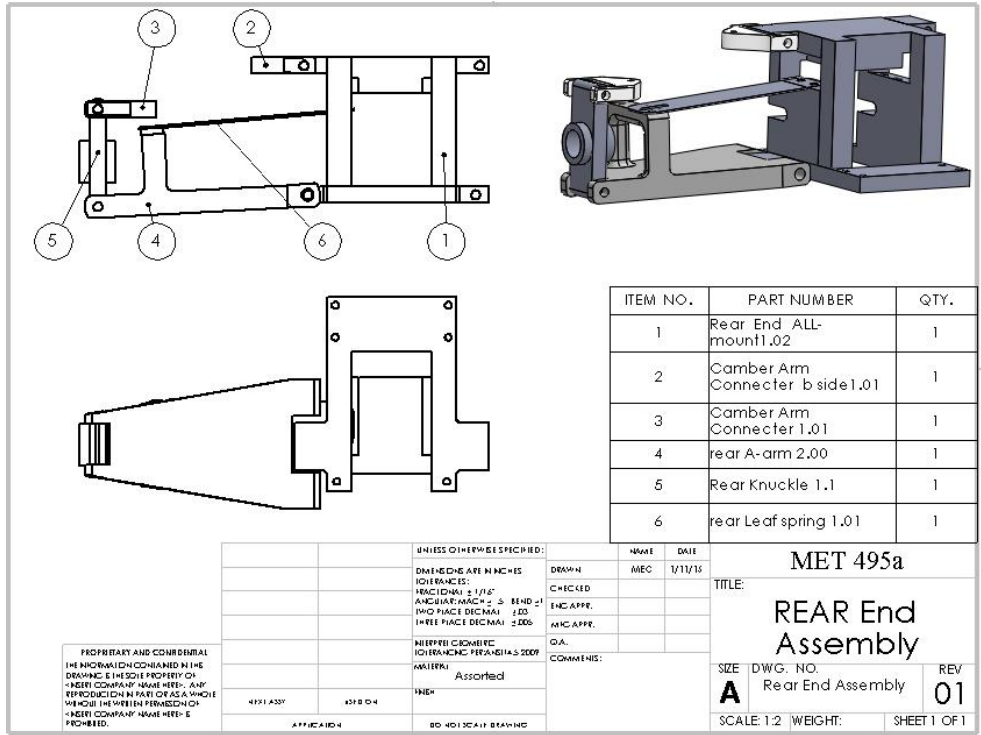

Figure 39 REAR ASSEMBLY

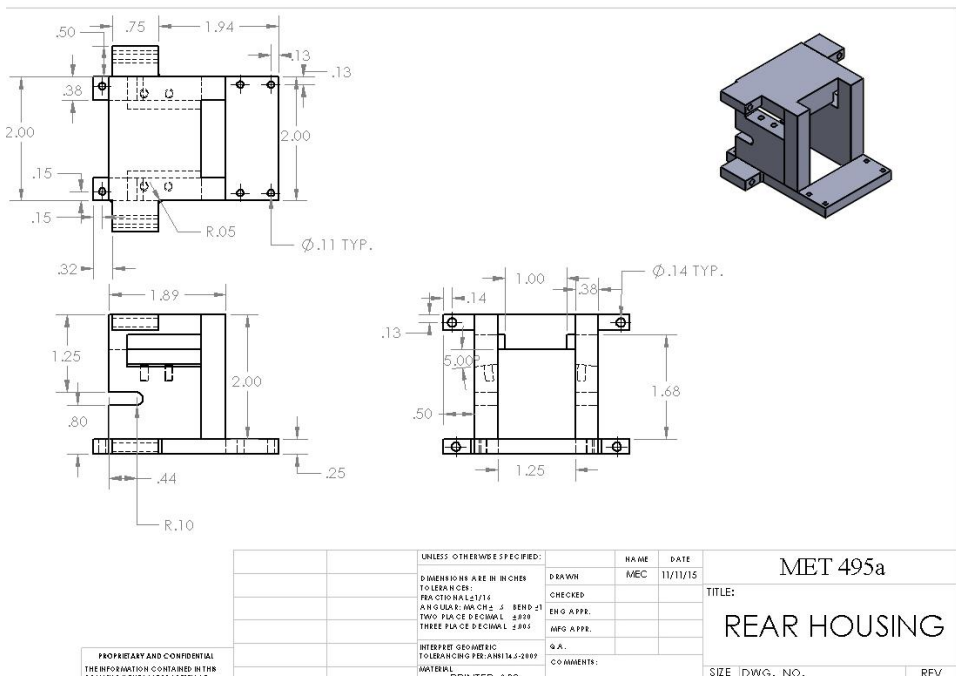

Figure 40 REAR ALLMOUNT/HOUSING

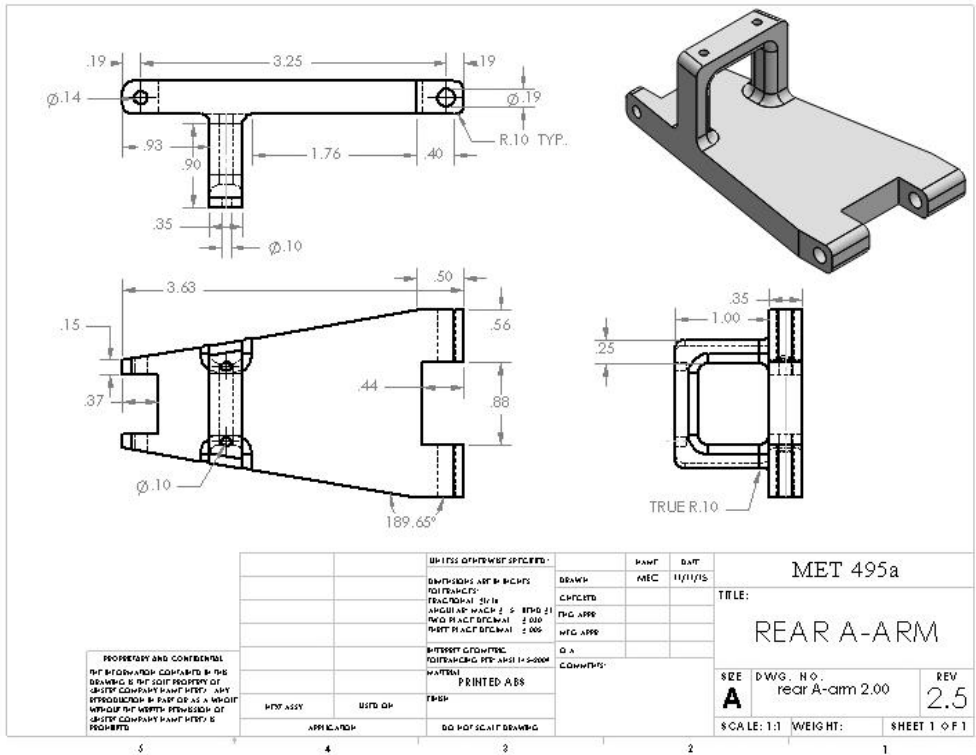

Figure 41 REAR A-ARM

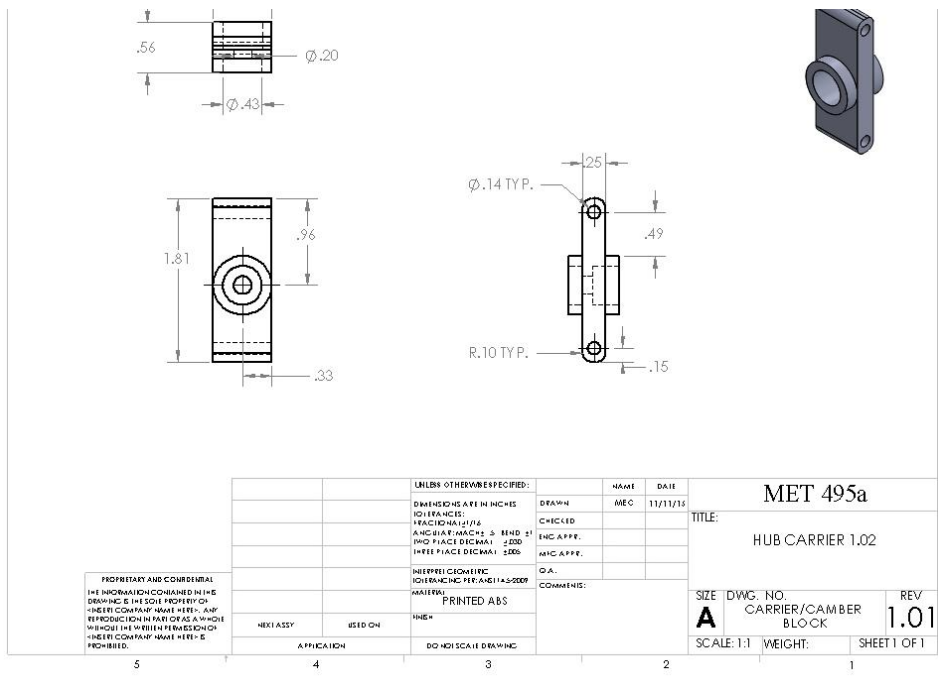

Figure 42 HUB CARRIER

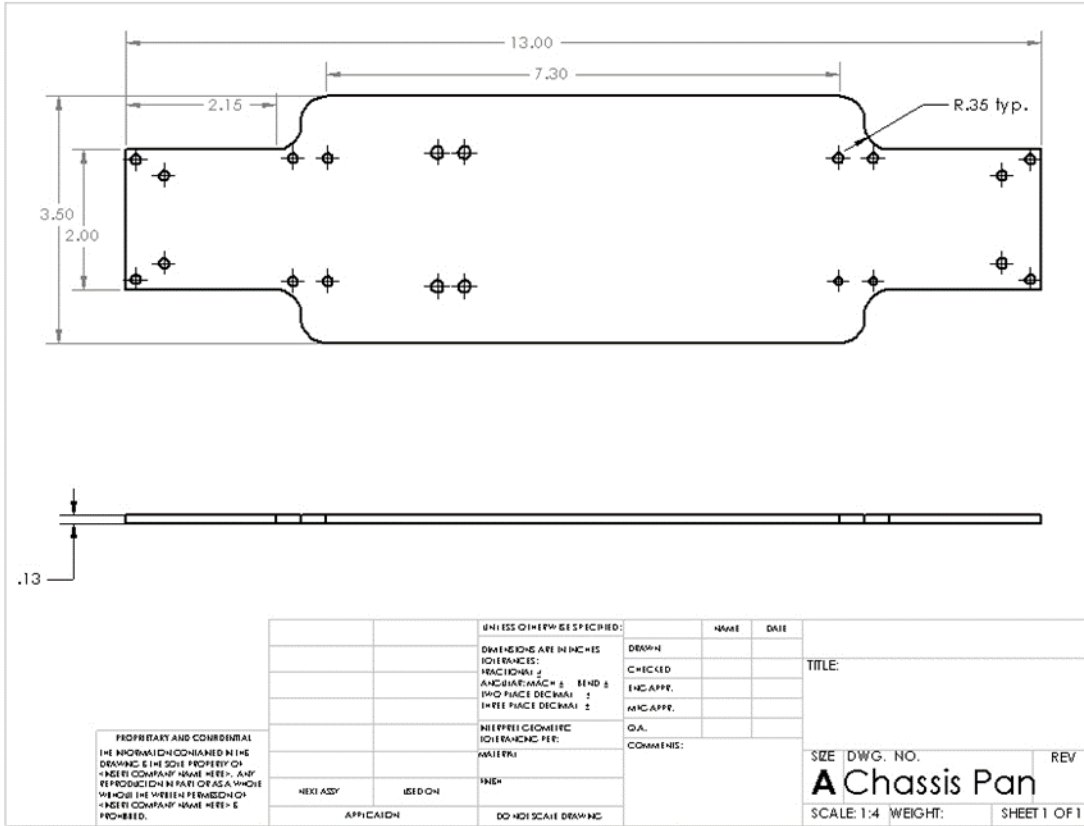

Figure 43 CHASSIS PAN

## Appendix C – Parts List

Parts and Estimated Cost List							
Part #	Name	Material	Stock	Manufacture method (or Purchase)	Unit Cost (\$)	Quantity	Total Cost
1	A-arm	1061 Aluminum	1/4" Plate	Water-jet	\$ 25.00	4	\$ 100.00
2	Caster Block	Printed ABS	null	3-D Printed	\$ 5.00	2	\$ 10.00
3	Steering knuckle	Printed ABS	null	3-D Printed	\$ 3.00	2	\$ 6.00
4	Hub Carrier	Printed ABS	null	3-D Printed	\$ 5.00	2	\$ 10.00
5	Stub Axle	Stainless Steel	1/2"x 3/16" D	Purchase	\$ 4.00	4	\$ 16.00
6	King pin	Stainless Steel		Purchase	\$ 5.00	2	\$ 10.00
7	Wheel Nut	1045 Steel	1/4" D	Purchase	\$ 4.00	4	\$ 16.00
8	Threaded Camber Link	Abs/stainless		Purchase	\$ 10.00	2	\$ 20.00
9	Shock Tower	1061 Aluminum	1/4" Plate	Water-jet	\$ 25.00	2	\$ 50.00
10	Drive Hex	1045 Steel		Purchase	\$ 2.00	2	\$ 4.00
11	Tires+Wheels	Rubber+plastic	4" D	Purchase	\$ 5.00	4	\$ 20.00
12	Shocks	Plastic+Steel Piston	2"	Purchase	\$ 4.00	8	\$ 32.00
13	Steering Servo	Steel Gearbox Plastic Housing	6 in^3	Purchase	\$ 30.00	1	\$ 30.00
14	Steering Arm	Printed ABS	null	Purchase	\$ 3.00	2	\$ 6.00
15	Threaded Steering Linkage	Steel rod + plastic boot	2"	Purchase	\$ 5.00	2	\$ 10.00
16	Threaded Steering Linkage	Steel rod + plastic boot	4"	Purchase	\$ 9.00	2	\$ 18.00
17	Sterring Pin	Stainless Steel	1 1/4"	Purchase	\$ 4.00	4	\$ 16.00
18	Base Plate	1061 Aluminum	1/4" Plate	Purchase	\$ 20.00	1	\$ 20.00
19	Support Structure	1061 Aluminum	1/4" Plate	Purchase	\$ 10.00	1	\$ 10.00
20	Hub Nut	Stainless Steel	3/16"	Purchase	\$ 2.00	2	\$ 4.00
						Total	\$ 408.00

Table 3 Early parts list and estimate on budget.

## Appendix D – Budget

Steering and Suspension Parts List					
Part #	Name	Manufacture method (or Purchase)	Unit Cost (\$)	Quantity	Total Cost
1	A-arm	3-D Printed	\$ 6.00	3.96	\$ 23.76
2	Rear A-arm	3-D Printed	\$ 6.00	3.84	\$ 23.04
3	Caster Block	3-D Printed	\$ 6.00	0.52	\$ 3.12
4	Steering knuckle Left	3-D Printed	\$ 6.00	0.3	\$ 1.80
5	Steering knuckle Right	3-D Printed	\$ 6.00	0.3	\$ 1.80
6	Hub Carrier	3-D Printed	\$ 6.00	0.6	\$ 3.60
7	Front All mount	3-D Printed	\$ 6.00	4.88	\$ 29.28
8	Rear All mount	3-D Printed	\$ 6.00	4.92	\$ 29.52
9	Hex Nut,Stub axle,washers	Purchase	\$ 13.00	1	\$ 13.00
10	Tires+Wheels	Purchase	\$ 19.99	1	\$ 19.99
11	Steering Servo	Purchase	\$ 19.90	1	\$ 19.90
12	Threaded Steering Linkage 3.3'	Purchase	\$ 3.99	2	\$ 7.98
13	Threaded Steering Linkage 2"	Purchase	\$ 7.58	3	\$ 22.74
14	Chassis Plate	Purchase	\$ -	1	\$ -
15	Camber Rod connector b side	3-D Printed	\$ 6.00	0.52	\$ 3.12
16	Camber Rod connector c side	3-D Printed	\$ 6.00	0.52	\$ 3.12
17	leaf spring	Cut/Grind	\$ 20.00	1	\$ 20.00
				Total	\$ 205.77

Table 4 Budget

## Appendix E -- Schedule

Fall Schedule		Fall (Weeks)											Finals
Task (Milestone)	Description	1	2	3	4	5	6	7	8	9	10	11	Finals
Proposal URL / Problem Statement	Turn In Website URL	█											
<a href="#">Proposal Project Approval</a>	Get Project Approved		◀										
Proposal Function Statements	Turn In Function Statements			█									
Proposal Requirement Statements	Turn In Requirement Statements				█								
Proposal Design/Radd	Turn in Section Design					█							
Proposal Analysis	Turn in Analysis Section						█						
Proposal Methods/Construction	Turn in Methods Section							█					
Proposal Testing/Predictions	Turn in Testing Section								█				
Proposal Testing Methods	Turn in Predictions Under testing									█			
Proposal Schedule	Turn in Schedule Section										█		
Proposal Budget	Turn in Budget Section											█	
Proposal Drawings	Turn in and prepare all drawings												█
Proposal Presentation	Turn in PP Presentation of Proposal												█
<a href="#">Complete Proposal</a>	Turn in Completed Proposal												◀

Figure 44 Fall Schedule

		Winter (weeks)										
Winter Schedule		1	2	3	4	5	6	7	8	9	10	Finals
Updated Proposal	Polished Proposal	█										
Water Jet Cutting Drawings	Prepare orders for Manufacturer	█	█									
Water Jet Cutting Orders in	Turn in Manufacturer orders		█	█								
Printing Steering prepared to print	Prepare STL files for printing		█	█	█							
Print Parts	Turn in Print Orders		█	█	█							
Assemble Suspension System	Complete Suspension assembly					◊						
Print Steering Knuckle and Arm	Prepare Stls and turn in to Print				█	█	█					
Assembling Steering Linkage	Steering System				█	█	█	█				
Assemble Steering System	Completed Steering System								◊			
Webpage	Complete Webpage		█						█	█		
Combine assemblies on Chassis pan	Combine All Systems										◊	
Completed Systems Driving	Full Assembly Driving											◊

(a)

Detailed Winter Schedule		Week										
Task		1	2	3	4	5	6	7	8	9	10	Finals
Updated Proposal	Polished Proposal	█										
Order Parts	Steering linkage, Servo,Tires,Hex Nut, Leaf spring mat		█									
Prepare STL Files For Print	All Printed Parts		█									
Drill out and dry fit all printed parts	Post Print Processing on 3-d Printed Parts			█	█							
	Ream Front end all mount			█	█							
	Ream Front A-Arms			█	█							
	Ream Front End Camber Block			█	█							
	Ream Rear end All Mount			█	█							
	Rear end A-Arm			█	█							
	Rear End Hub Knuckle			█	█							
Cut leaf springs	Cut/grind leaf springs		█									
Assemble Suspension System	Complete Suspension assembly					◊						
Print Steering Knuckle and Arm	Prepare Stls and turn in to Print					█	█					
Drill out and dry fit steering components	Post Print Processing on 3-d Printed Parts					█	█					
	Ream Steering Knuckles					█	█					
	Ream Steering Connector					█	█					
	Ream Steering Servo Connector					█	█					
	Dry fit all components					█	█					
Suspension Tuning	Suspension System adjustments					█	█					
Steering Linkage nTuning	Steering System adjustments					█	█					
Assemble Steering System	Completed Steering System								◊			
Webpage	Complete Webpage								█	█		
Combine assemblies on Chassis pan	Combine All Systems										◊	
Completed Systems Driving	Full Assembly Driving											◊

Figure 45 Winter Schedule (a) and Detailed

		Spring (weeks)										
Spring Schedule		1	2	3	4	5	6	7	8	9	10	Finals
Testing Course slalom and speed	Test the Slalom/Speed capabilities of Baja Car	█	█	█	█							
Testing Drop Test	Drop Baja Car to test suspension capabilities	█	█	█	█							
Testing Terrain	Test vehicle in different conditions and terrain	█	█	█	█							
Competition	Compete in competition						◊					
Source Presentaion	Prepare a source poster and present								█	█		
Project End	Finish Whoo hoo											End

Figure 46 Spring Schedule

Project Milestone Schedule		Fall				Winter					Spring	
Milestone	Description	Week 3	Week 7	Week 10	Finals Week	Week 4	Week 8	Week 8	Week 9	Week 10	Week 5	Week 10
Project Approval	Get Project Approved	◁										
Testing Methods	Turn in Predictions		◁									
Analysis	Turn in Analysis Section			◁								
Complete Proposal	Turn in Completed Proposal				◁							
Assemble Suspension System	Complete Suspension assembly					◁						
Assemble Steering System	Completed Steering System						◁					
Webpage	Complete Webpage							◁				
Combine all assemblies	Combine All Systems								◁			
Completed Systems Driving	Full Assembly Driving									◁		
Competition	Compete in competition										◁	
Project End	Completion											◁

Figure 47 Milestone Schedule

Project Schedule		Approx. Hrs	Fall (Weeks)											Winter (weeks)										Spring (weeks)																										
Task (Milestone)	Description		1	2	3	4	5	6	7	8	9	10	11	Finals	1	2	3	4	5	6	7	8	9	10	Finals	1	2	3	4	5	6	7	8	9	10	Finals														
Proposal URL / Problem Statement	Turn In Website URL	4	█																																															
Proposal Project Approval	Get Project Approved	2		█																																														
Proposal Function Statements	Turn In Function Statements	8		█	█	█	█	█	█	█	█	█	█	█																																				
Proposal Requirement Statements	Turn In Requirement Statements	6			█	█	█	█	█	█	█	█	█	█																																				
Proposal Design/Radd	Turn in Section Design	12				█	█	█	█	█	█	█	█	█																																				
Proposal Analysis	Turn in Analysis Section	10					█	█	█	█	█	█	█	█																																				
Proposal Methods/Construction	Turn in Methods Section	6						█	█	█	█	█	█	█																																				
Proposal Testing/Predictions	Turn in Testing Section	6								█	█	█	█	█																																				
Proposal Testing Methods	Turn in Predictions Under testing	6																																																
Proposal Schedule	Turn in Schedule Section	6																																																
Proposal Budget	Turn in Budget Section	6																																																
Proposal Drawings	Turn in and prepare all drawings	12																																																
Proposal Presentation	Turn in PP Presentation of Proposal	4																																																
Complete Proposal	Turn in Completed Proposal	10																																																
Winter Schedule																																																		
Updated Proposal	Polished Proposal	10																																																
Water Jet Cutting Drawings	Prepare orders for Manufacturer	7																																																
Water Jet Cutting Orders in	Turn in Manufacturer orders	4																																																
Printing Steering prepared to print	Prepare STL files for printing	7																																																
Print Parts	Turn in Print Orders	8																																																
Assemble Suspension System	Complete Suspension assembly	8																																																
Print Steering Knuckle and Arm	Prepare Stls and turn in to Print	5																																																
Assembling Steering Linkage	Steering System	5																																																
Assemble Steering System	Completed Steering System	5																																																
Webpage	Complete Webpage	7																																																
Combine assemblies on Chassis pan	Combine All Systems	2																																																
Completed Systems Driving	Full Assembly Driving	10																																																
Spring Schedule																																																		
Testing Course slalom and speed	Test the Slalom/Speed capabilities of Baja Car	10																																																
Testing Drop Test	Drop Baja Car to test suspension capabilities	10																																																
Testing Terrain	Test vehicle in different conditions and terrain	10																																																
Competition	Compete in competition	6																																																
Source Presentaion	Prepare a source poster and present	3																																																
Project End	Project is complete and turned in																																																	
	Total Hrs.	215																																																

Figure 48 Full Year Schedule

## Appendix F- Test Summary Data Sheets

Baja Car Test Data Summary Sheet	Michael Cox MET 495A
<i>Drop Test</i>	<i>Date:</i> <i>Location:</i>
Vehicle weight	4 lb.
Drop Height	24"
Requirement:	No failure and full function after a 24" Drop
Pass	
Fail	
Failure Location(s)	
Notes:	

Figure 49 Drop Test Data Summary Sheet



## Appendix G- Resume/Vita

MICHAEL E. COX

310 North Main Street | Ellensburg, WA | 509-899-5358 | [coxmi@cwu.edu](mailto:coxmi@cwu.edu)

### OBJECTIVE

An entry level position or internship that utilizes my training and education in the field of engineering.

### EDUCATION

Bachelor of Science , Mechanical Engineering Technologies  
Central Washington University, Ellensburg WA.

Graduation June 2016

Major: Mechanical Engineering Technologies current cumulative GPA 3.308

### SKILLS & ABILITIES

#### [Management]

- Engineering Project Cost and Management Courses: Central Washington University,
- Su Chef, Starlight Lounge, Ellensburg, WA, 989826. Managed numerous employees, performed ordering, menu planning, cost analysis.

#### [Leadership]

- President of the American Society of Mechanical Engineers C.W.U. Chapter (2015-16)
- Secretary of the American Society of Mechanical Engineers C.W.U. Chapter (2014-15)

#### [Certifications/Skills]

- Certified SOLIDWORKS Associate (2013): C.S.W.A. Experience and working knowledge of 3-dimensional modeling, drafting, rapid prototyping and engineering fundamentals.
- Experience Machining (through coursework @ CWU): Working knowledge of various machining equipment including Mills (horizontal/vertical), Engine Lathe, Bench Grinder, Band Saw, etc. Also can apply layouts, scribe measure and mark according to drawings.
- Experience CNC Machining (through coursework @ CWU): Working knowledge of multiple 3-dimensional modeling programs as well as experience operating and writing code for CNC lathe and Mill.

### EXPERIENCE

CAD Technician: CWU Facilities Management: Projects and Planning Dept.

06/06/15 - Present

400 E University Way, Ellensburg, WA 98926 (509)933-3000

Direct Supervisor : Shane Scott (ext. 1289)

- Drawing, modeling, and dimensioning numerous construction projects from large fencing to office remodels.
- Prepared numerous reports including AimCAD, trip hazard, departmental space, construction progress and other types of reports.

Cook: Bleachers Sports Bar and Grill

10/10/10 -06/01/14

730 E University Way, Ellensburg, WA 98926 (509) 962-2337

Direct Supervisor: Charlie Simpson (Owner)

- Cooked, prepared, portioned food for restaurant. Also ordered supplies, and scheduled employees.
- Letter of Recommendation available from owner Charlie Simpson

Figure 50: General Resume

## Appendix H FEA (Finite Element Analysis Reports)

FEA REPORT 1.01

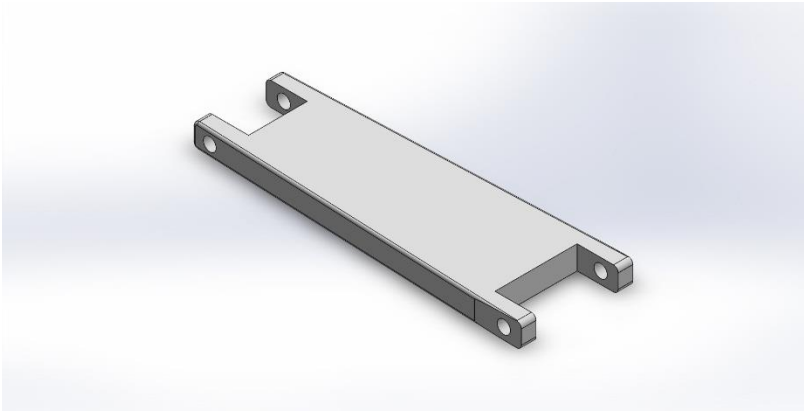

# Description

FEA analysis of Part A-arm 1.01

## Simulation of A-arm 1.01

**Date:** Tuesday, December 08, 2015  
**Designer:** Michael Cox  
**Study name:** SimulationXpress Study  
**Analysis type:** Static

### Table of Contents

Description	57
Assumptions	58
Model Information	58
Material Properties	59
Loads and Fixtures	59
Mesh Information	60
Study Results	61
Conclusion	63

# Assumptions

## Model Information

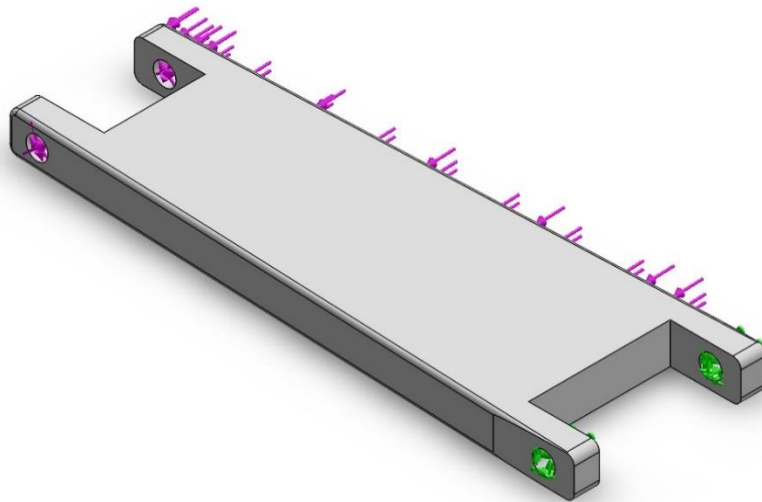

Model name: A-arm 1.01  
Current Configuration: Default

### Solid Bodies

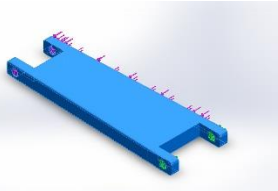
Document Name and Reference	Treated As	Volumetric Properties	Document Path/Date Modified
<p>Cut-Extrude3</p> 	Solid Body	Mass:0.0138003 kg Volume:1.31431e-005 m <sup>3</sup> Density:1050 kg/m <sup>3</sup> Weight:0.135243 N	N:\CoxMI\SENIOR PROJECT\Suspension Solidworks\A-arm 1.01.SLDPRT Dec 07 16:05:02 2015

# Material Properties

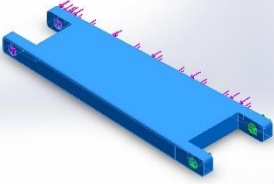
Model Reference	Properties	Components
	Name: <b>Printed ABS</b> Model type: <b>Linear Elastic Isotropic</b> Default failure criterion: <b>Max von Mises Stress</b> Yield strength: <b>4.13685e+007 N/m<sup>2</sup></b> Tensile strength: <b>2.20632e+007 N/m<sup>2</sup></b>	<b>SolidBody 1(Cut-Extrude3)(A-arm 1.01)</b>

# Loads and Fixtures

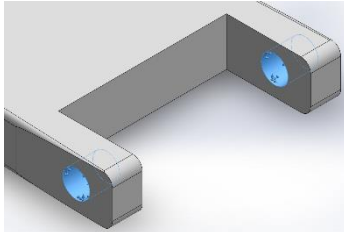
Fixture name	Fixture Image	Fixture Details
Fixed-1		Entities: <b>2 face(s)</b> Type: <b>Fixed Geometry</b>

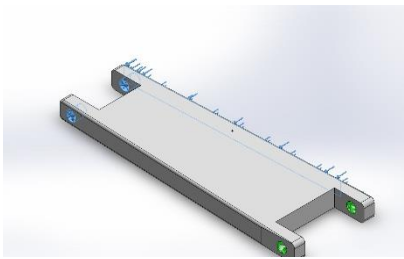
Load name	Load Image	Load Details
Force-1		Entities: <b>3 face(s)</b> Type: <b>Apply normal force</b> Value: <b>586 lbf</b>

# Mesh Information

<b>Mesh type</b>	Solid Mesh
<b>Mesher Used:</b>	Curvature based mesh
<b>Jacobian points</b>	4 Points
<b>Maximum element size</b>	0 in
<b>Minimum element size</b>	0 in
<b>Mesh Quality</b>	High

## Mesh Information - Details

<b>Total Nodes</b>	13170
<b>Total Elements</b>	7805
<b>Maximum Aspect Ratio</b>	11.602
<b>% of elements with Aspect Ratio &lt; 3</b>	97.3
<b>% of elements with Aspect Ratio &gt; 10</b>	0.115
<b>% of distorted elements(Jacobian)</b>	0
<b>Time to complete mesh(hh:mm:ss):</b>	00:00:01
<b>Computer name:</b>	TURTLE-PC

Model name: A-1.m 1.01  
Study name: Simulation(press) Study(-Default)  
Mesh type: Solid mesh

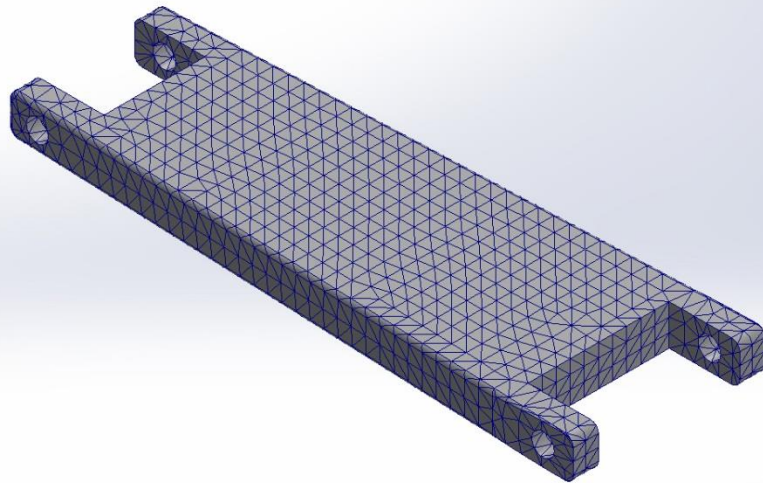

# Study Results

Name	Type	Min	Max
Stress	VON: von Mises Stress	385023 N/m <sup>2</sup> Node: 2765	4.5724e+008 N/m <sup>2</sup> Node: 20

Model name: A-arm 1.01  
 Study name: SimulationXpress Study-Default  
 Plot type: Static nodal stress Stress  
 Deformation scale: 0.59838

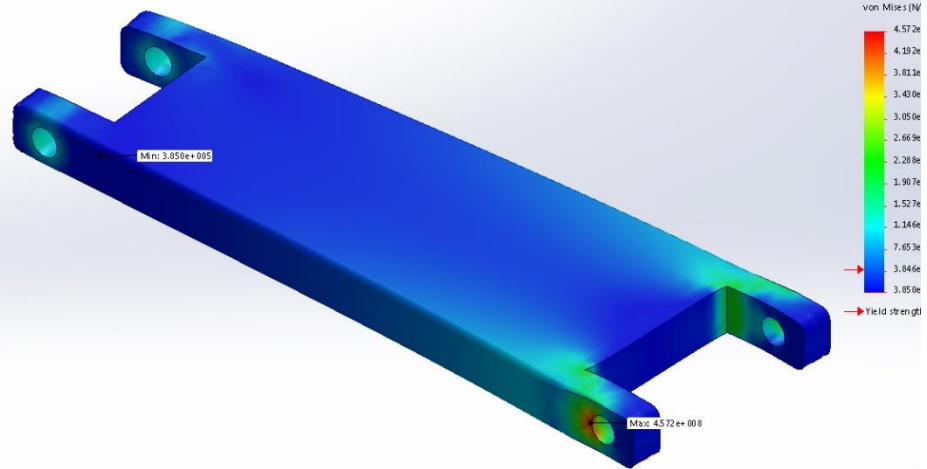

A-arm 1.01-SimulationXpress Study-Stress-Stress

Name	Type	Min	Max
Displacement	URES: Resultant Displacement	0 mm Node: 1	15.5685 mm Node: 263



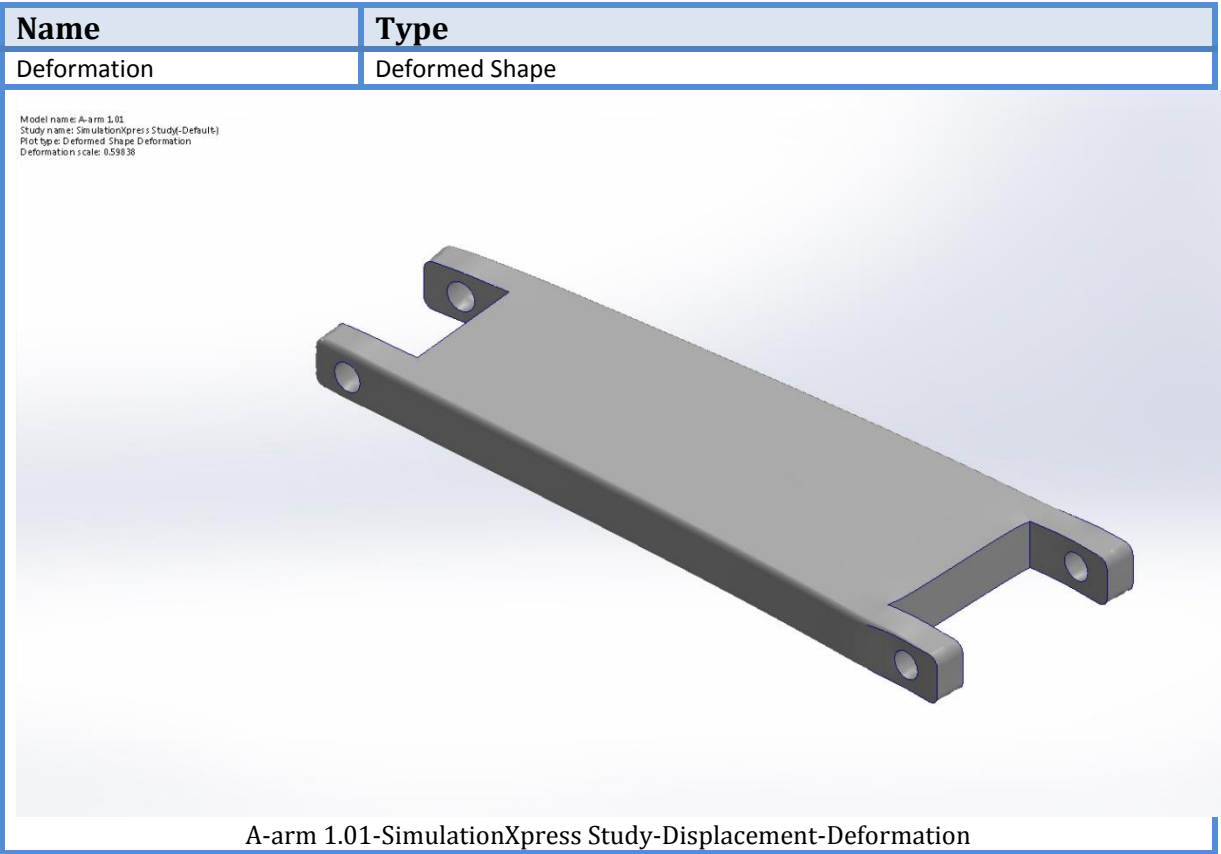
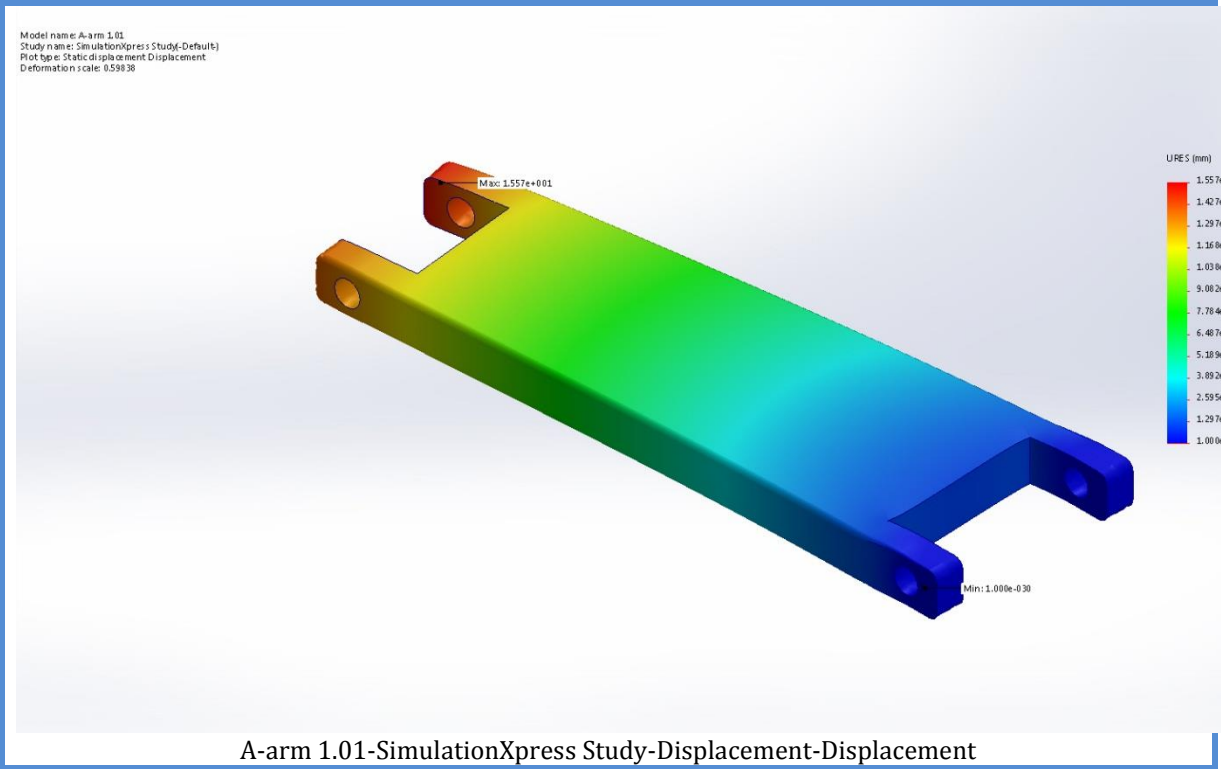

Name	Type	Min	Max
Factor of Safety	Max von Mises Stress	0.0904744 Node: 20	107.444 Node: 2765

Model name: A-arm 1.01  
Study name: SimulationXpress Study-Default  
Plot type: Factor of Safety Factor of Safety  
Criterion : Max von Mises Stress  
Red = FOS = 1 = Blue

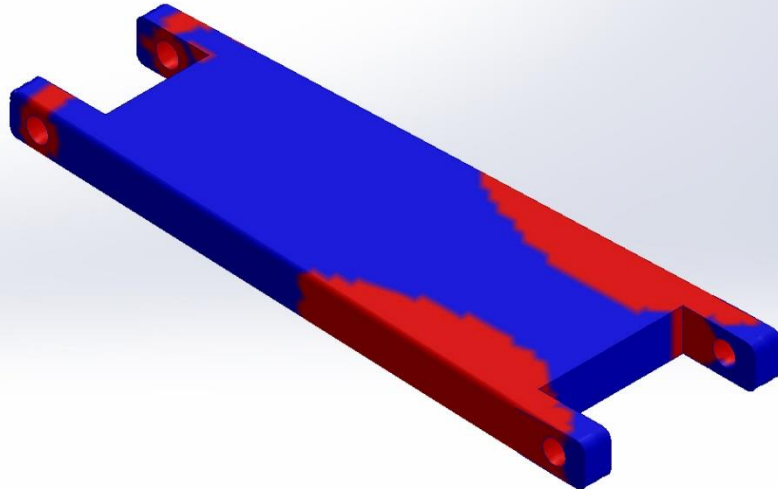

A-arm 1.01-SimulationXpress Study-Factor of Safety-Factor of Safety

## Conclusion

Fail

Re-design with channels to increase yield strength at points of failure.

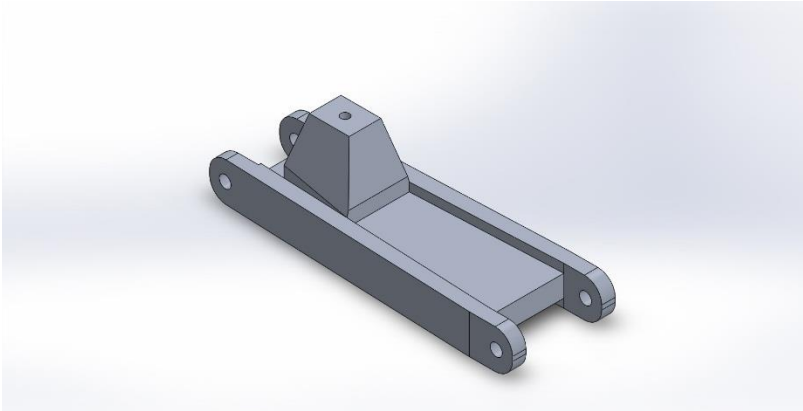

## Description

FEA A-Arm 1.02 Printed ABS

## Simulation of A-arm 1.02

**Date:** Tuesday, December 08, 2015  
**Designer:** Michael Cox  
**Study name:** SimulationXpress Study  
**Analysis type:** Static

### Table of Contents

Description	64
Assumptions	65
Model Information	65
Material Properties	66
Loads and Fixtures	66
Mesh Information	67
Study Results	68
Conclusion	70

# Assumptions

## Model Information

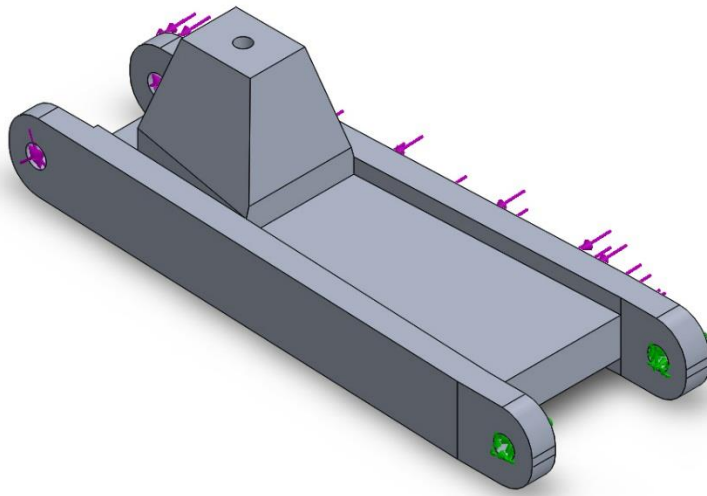

Model name: A-arm 1.02  
Current Configuration: Default

### Solid Bodies

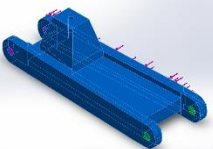
Document Name and Reference	Treated As	Volumetric Properties	Document Path/Date Modified
 Cut-Extrude10	Solid Body	Mass:0.127065 lb Volume:1.30265 in <sup>3</sup> Density:0.0975437 lb/in <sup>3</sup> Weight:0.126979 lbf	N:\CoxMI\SENIOR PROJECT\Suspension Solidworks\A-arm 1.02.SLDPRT Dec 07 22:26:51 2015

# Material Properties

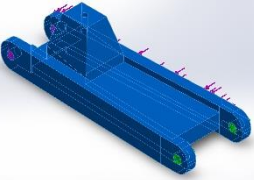
Model Reference	Properties	Components
	Name: <b>1060 Alloy</b> Model type: <b>Linear Elastic Isotropic</b> Default failure criterion: <b>Max von Mises Stress</b> Yield strength: <b>3999.3 psi</b> Tensile strength: <b>9998.26 psi</b>	<b>SolidBody 1(Cut-Extrude10)(A-arm 1.02)</b>

# Loads and Fixtures

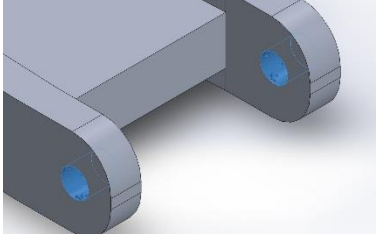
Fixture name	Fixture Image	Fixture Details
Fixed-1		Entities: <b>2 face(s)</b> Type: <b>Fixed Geometry</b>

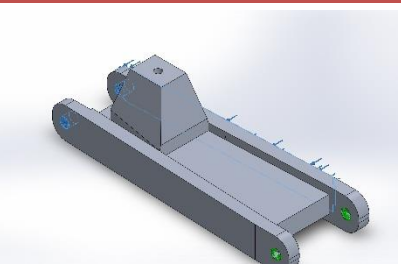
Load name	Load Image	Load Details
Force-1		Entities: <b>3 face(s)</b> Type: <b>Apply normal force</b> Value: <b>586 lbf</b>



# Mesh Information

<b>Mesh type</b>	Solid Mesh
<b>Mesher Used:</b>	Curvature based mesh
<b>Jacobian points</b>	4 Points
<b>Maximum element size</b>	0 in
<b>Minimum element size</b>	0 in
<b>Mesh Quality</b>	High

## Mesh Information - Details

<b>Total Nodes</b>	13781
<b>Total Elements</b>	8438
<b>Maximum Aspect Ratio</b>	11.919
<b>% of elements with Aspect Ratio &lt; 3</b>	98.6
<b>% of elements with Aspect Ratio &gt; 10</b>	0.0119
<b>% of distorted elements(Jacobian)</b>	0
<b>Time to complete mesh(hh:mm:ss):</b>	00:00:01
<b>Computer name:</b>	TURTLE-PC

Model name: A-arm 1.02  
Study name: Simulation(press Study-Default)  
Mesh type: Solid mesh

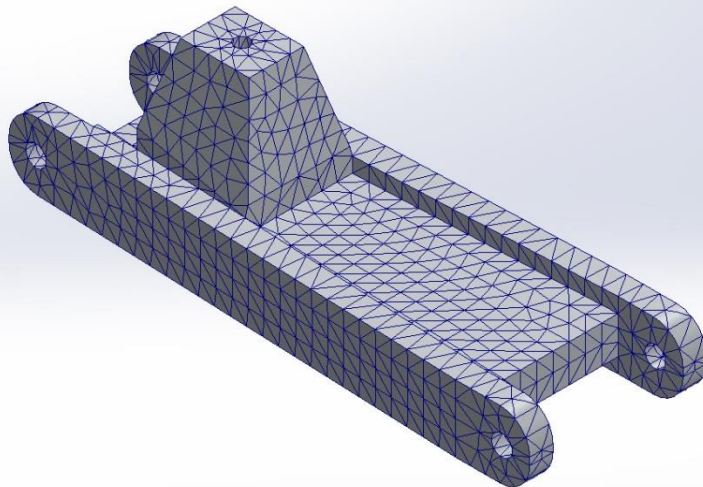

# Study Results

Name	Type	Min	Max
Stress	VON: von Mises Stress	7.62641 psi Node: 299	57131 psi Node: 13449

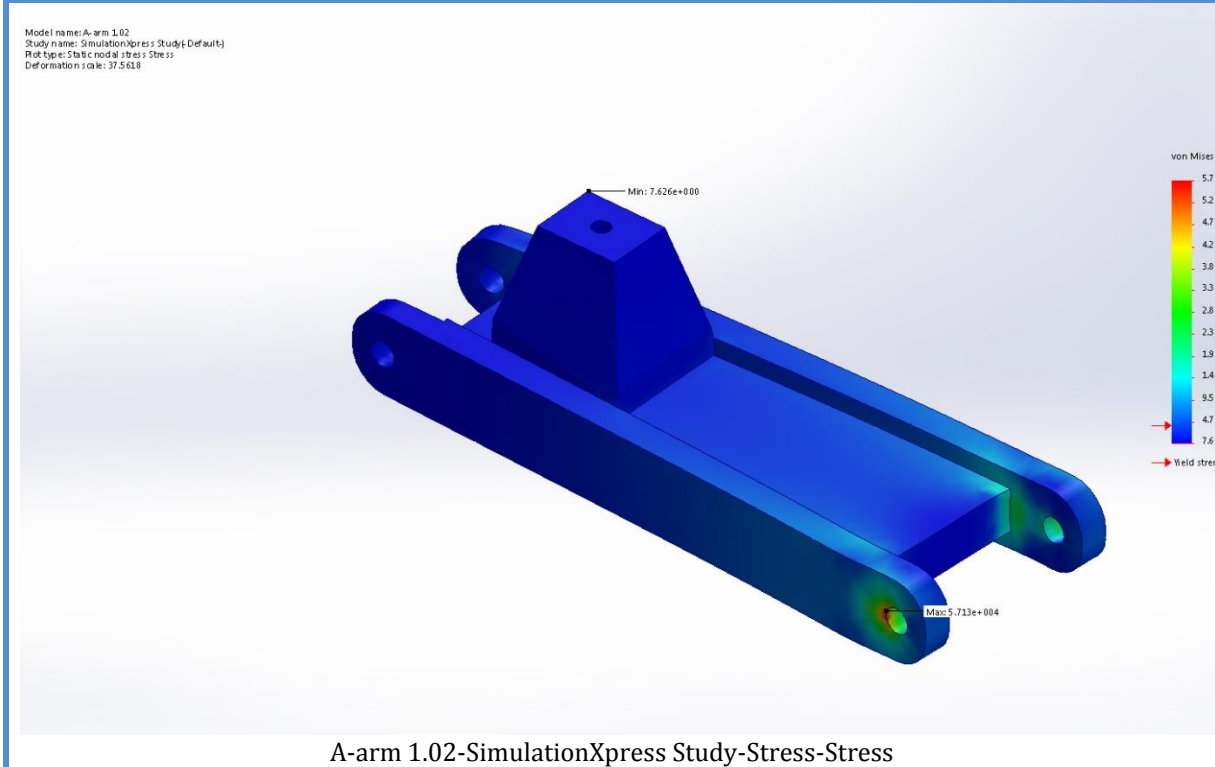

Name	Type	Min	Max
Displacement	URES: Resultant Displacement	0 in Node: 27	0.00975828 in Node: 872

Model name: A-arm 1.02  
 Study name: SimulationXpress Study-Default  
 Plot type: Static displacement-Displacement  
 Deformation scale: 37.5x18

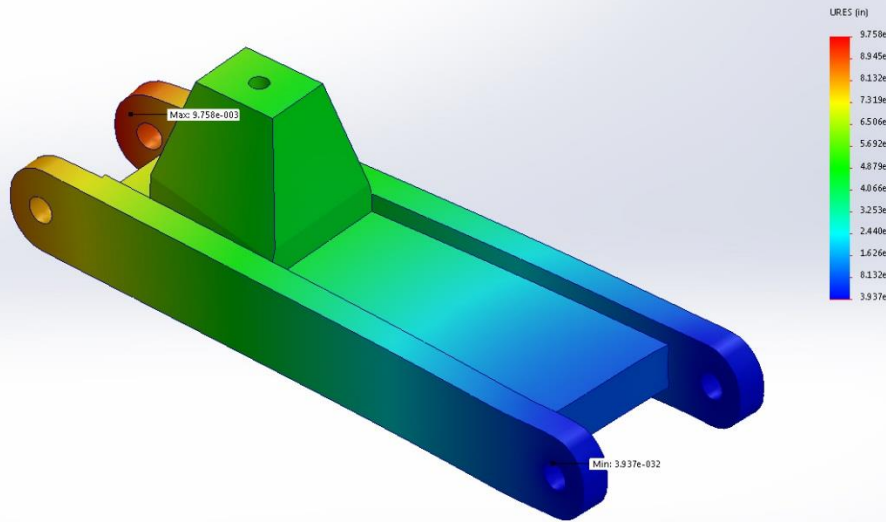

A-arm 1.02-SimulationXpress Study-Displacement-Displacement

Name	Type
Deformation	Deformed Shape

Model name: A-arm 1.02  
 Study name: SimulationXpress Study-Default  
 Plot type: Deformed Shape-Deformation  
 Deformation scale: 37.5x18

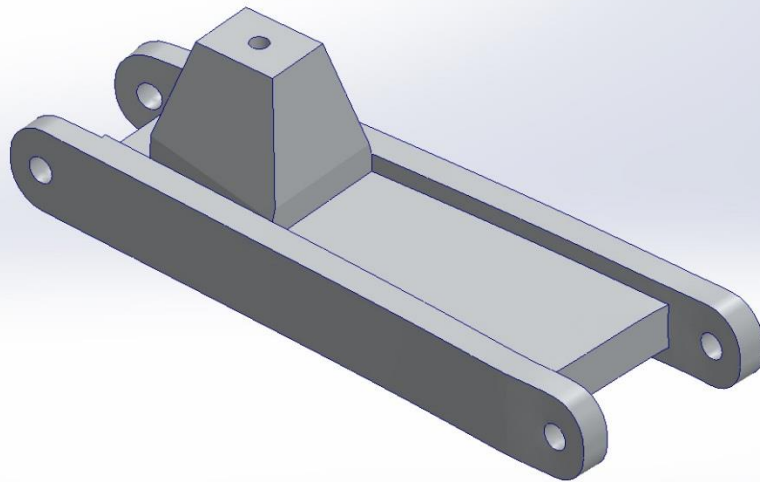

A-arm 1.02-SimulationXpress Study-Displacement-Deformation

Name	Type	Min	Max
Factor of Safety	Max von Mises Stress	0.0700023 Node: 13449	524.401 Node: 299

Model name: A-arm 1.02  
Study name: SimulationXpress Study1 (Default)  
Plot type: Factor of Safety/ Factor of Safety  
Criterion: Max von Mises Stress  
Red < FOS = 1 < Blue

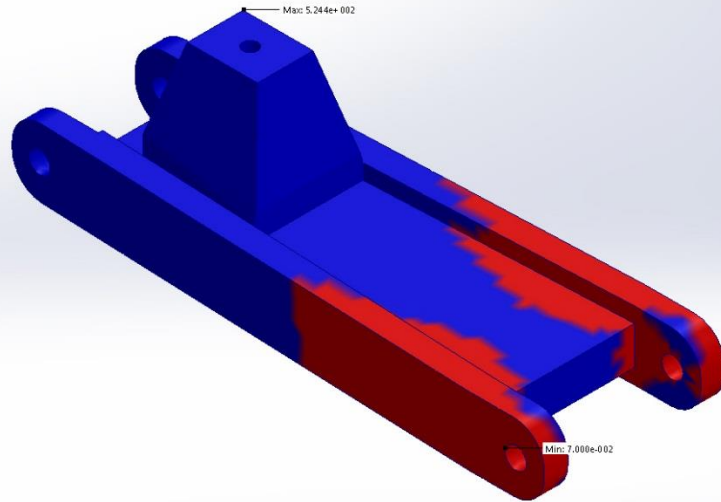

A-arm 1.02-SimulationXpress Study-Factor of Safety-Factor of Safety

## Conclusion

**FAIL**

Even With added Channels part still cannot withstand forces upon impact at 20 mph.

Total redesign of part necessary. Part Needs to be More symmetrical, triangular in shape and wider at the base.

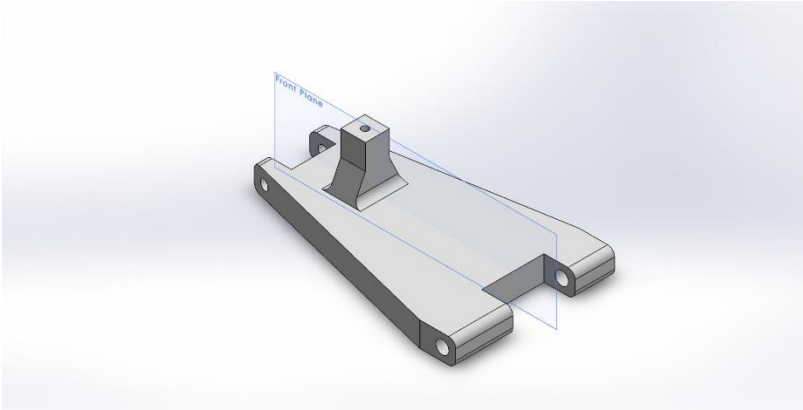

## Description

FEA analysis of Part A-arm 1.01

## Simulation of A-arm 2.50

**Date:** Tuesday, January 05, 2016

**Designer:** Michael Cox

**Study name:** SimulationXpress Study

**Analysis type:** Static

### Table of Contents

Description	71
Assumptions	72
Model Information	72
Material Properties	73
Loads and Fixtures	73
Mesh Information	74
Study Results	75
Conclusion	77

# Assumptions

## Model Information

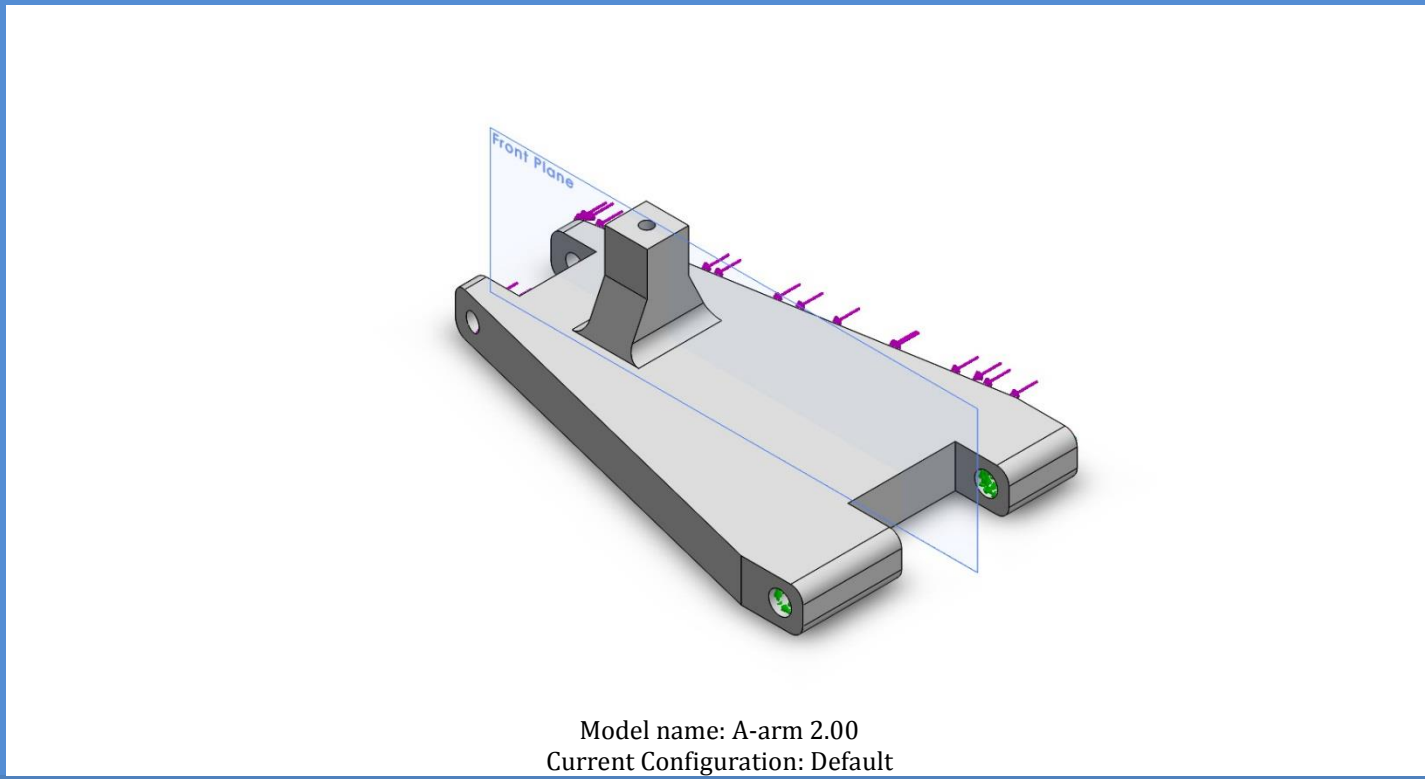

Model name: A-arm 2.00  
Current Configuration: Default

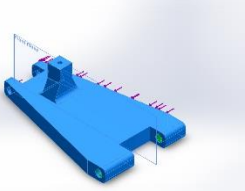
Solid Bodies			
Document Name and Reference	Treated As	Volumetric Properties	Document Path/Date Modified
Fillet2 	Solid Body	Mass:0.0750533 lb Volume:1.97854 in <sup>3</sup> Density:0.0379337 lb/in <sup>3</sup> Weight:0.0750024 lbf	N:\CoxMI\SENIOR PROJECT\Suspension Solidworks\A-arm 2.00.SLDPRT Jan 05 22:26:01 2016

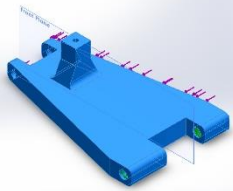

# Material Properties

Model Reference	Properties	Components
	Name: <b>Printed ABS</b> Model type: <b>Linear Elastic Isotropic</b> Default failure criterion: <b>Max von Mises Stress</b> Yield strength: <b>6000 psi</b> Tensile strength: <b>3200 psi</b>	<b>SolidBody 1(Fillet2)(A-arm 2.00</b>

# Loads and Fixtures

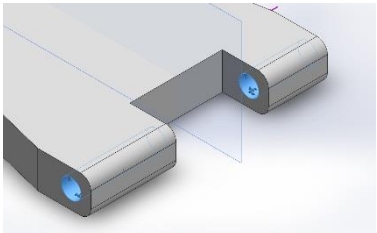
Fixture name	Fixture Image	Fixture Details
Fixed-3		Entities: <b>2 face(s)</b> Type: <b>Fixed Geometry</b>

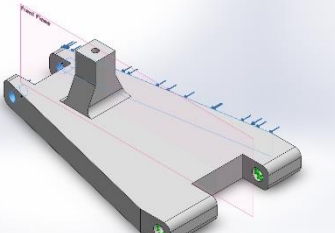
Load name	Load Image	Load Details
Force-3		Entities: <b>3 face(s), 1 plane(s)</b> Reference: <b>Front Plane</b> Type: <b>Apply force</b> Values: <b>---, ---, 290 lbf</b>

# Mesh Information

<b>Mesh type</b>	Solid Mesh
<b>Mesher Used:</b>	Standard mesh
<b>Automatic Transition:</b>	Off
<b>Include Mesh Auto Loops:</b>	Off
<b>Jacobian points</b>	4 Points
<b>Element Size</b>	0.0929445 in
<b>Tolerance</b>	0.00464723 in
<b>Mesh Quality</b>	High

## Mesh information - Details

<b>Total Nodes</b>	28246
<b>Total Elements</b>	17998
<b>Maximum Aspect Ratio</b>	4.5401
<b>% of elements with Aspect Ratio &lt; 3</b>	99.6
<b>% of elements with Aspect Ratio &gt; 10</b>	0
<b>% of distorted elements(Jacobian)</b>	0
<b>Time to complete mesh(hh:mm:ss):</b>	00:00:02
<b>Computer name:</b>	TURTLE-PC

# Study Results

Name	Type	Min	Max
Stress	VON: von Mises Stress	0.247426 psi Node: 15087	5353.77 psi Node: 44

Model name: A-arm 2.00  
 Study name: SimulationXpress Study-Default-  
 Plot type: Static nodal stress Stress  
 Deformation scale: 6.07557

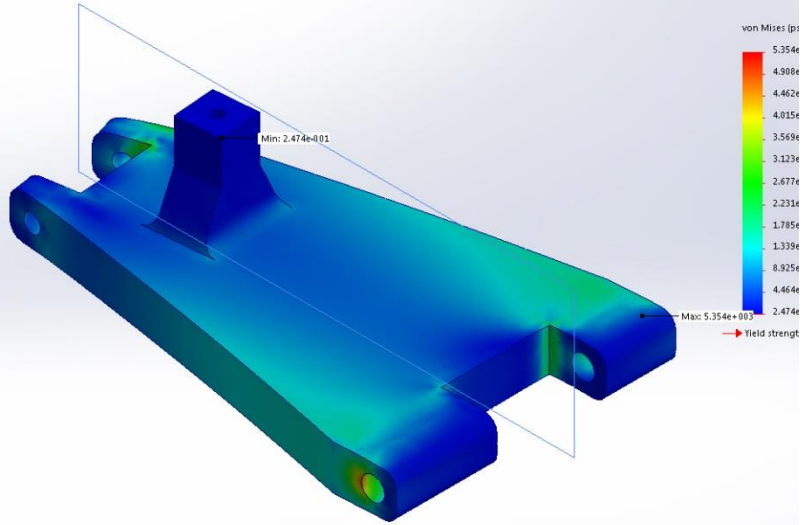

A-arm 2.00-SimulationXpress Study-Stress-Stress

Name	Type	Min	Max
Displacement	URES: Resultant Displacement	0 mm Node: 20	1.54657 mm Node: 22260

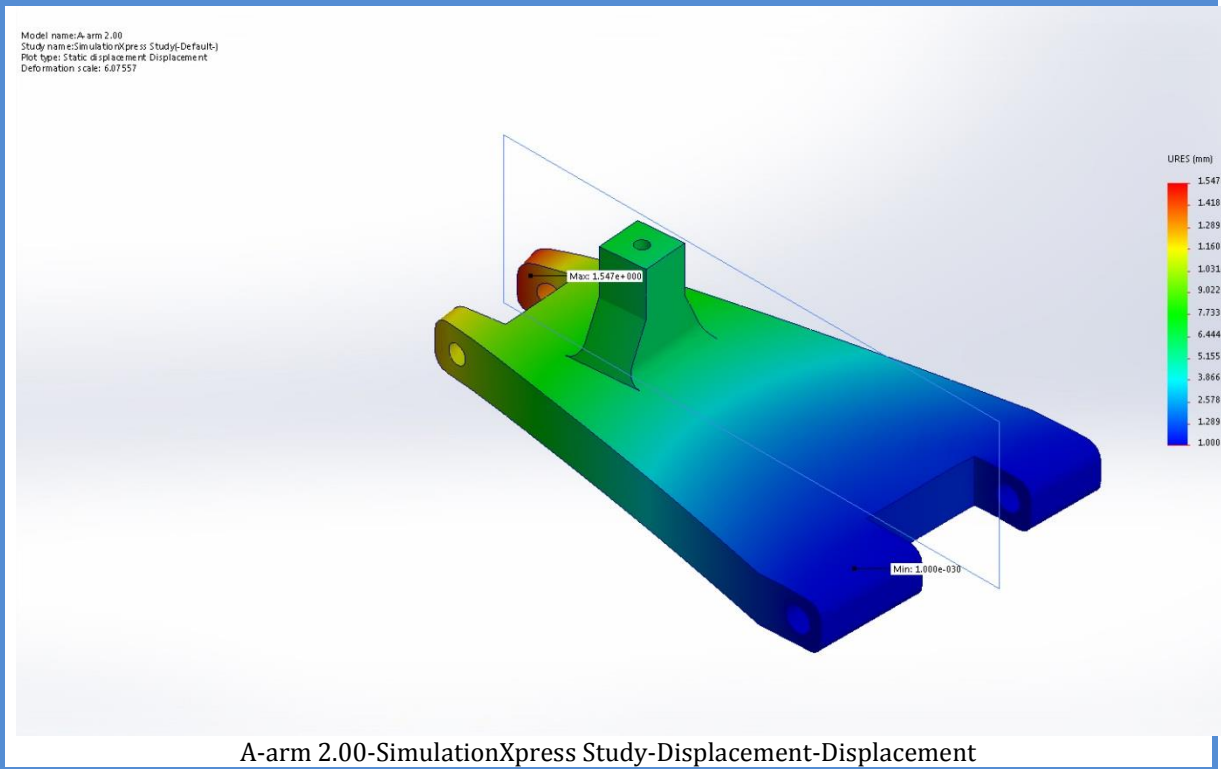

Name	Type
Deformation	Deformed shape

Model name: A-arm 2.00  
 Study name: SimulationXpress Study-Default  
 Plot type: Deformed shape Deformation  
 Deformation scale: 6.07557

A-arm 2.00-SimulationXpress Study-Displacement-Deformation

Name	Type	Min	Max
Factor of Safety	Max von Mises Stress	1.12071 Node: 44	24249.7 Node: 15087

Model name: A-arm 2.00  
 Study name: SimulationXpress Study (Default)  
 Plot type: Factor of Safety Factor of Safety  
 Criterion: Max vonMises Stress  
 Red < FOS = 1 < Blue

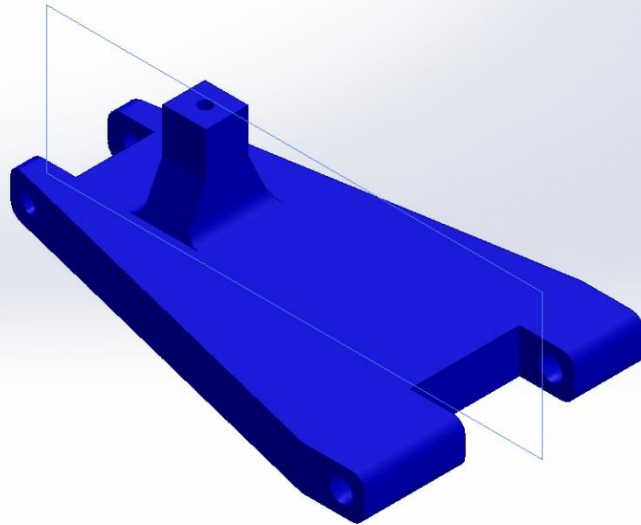

A-arm 2.00-SimulationXpress Study-Factor of Safety-Factor of Safety

## Conclusion

Success

Min. Safety Factor of 1.12

## **Appendix I** FINAL TESTING DOCUMENT

Michael Cox: Steering and suspension.

(Jason More: Drive train)

MET 495c

4/6/16

### Testing Design Guide: ASME Mini-Baja Car

#### Steering and Suspension Systems

##### **Introduction:**

The purpose of this testing guide is to determine if our project, the ASME mini-baja RC car can meet the requirements that were our target goal for the vehicle. The basic requirements are as follows:

- Shocks will have to be designed that can dampen the force of a drop from up to 24 inches.
- Suspension must support up to four pounds from a drop of 24 inches without chassis.
- Suspension must have at least 1.5" of up travel.
- Steering and suspension systems must operate, and articulate fully without interference between components.
- Steering system must allow vehicle to turn 180 Deg. in a 50" radius
- As per competition rules a minimum 20% of steering components must be store bought.
- As per competition rules design 50% of parts for interchangeability to allow for smaller parts stock.
- Systems must be fastened together with easily sourced fasteners.

The parameters of interest are performance of the vehicle, this entails the suspension must be able to withstand the rigors of the competition's course by supporting the vehicle without bottoming out and absorb shock sufficiently enough to prevent damage to any parts of vehicle. The steering must operate in a predictable manner and turn the vehicle in a fairly small radius so it will be easy to steer through complex obstacles and terrain.

It is predicted that the vehicle will meet or exceed all of the above listed requirements. Data Acquisition will be performed by my partner Jason Moore, and myself depending on the test, the primary method of acquisition will be filming, a stop watch and written records of performance.



		Spring (weeks)										
Spring Schedule		1	2	3	4	5	6	7	8	9	10	Finals
Testing Course slalom and speed	Test the Slalom/Speed capabilities of Baja Car											
Testing Drop Test	Drop Baja Car to test suspension capabilities											
Testing Terrain	Test vehicle in different conditions and terrain											
Competition	Compete in competition											
Source Presentaion	Prepare a source poster and present											
Project End	Finish Whoo hoo											End

Figure 51 Proposed Testing Schedule

**Method/Approach:**

Most of the test environment and resources for testing the vehicle systems will be found on campus or constructed on campus in the Hogue FLUKE lab. The indoor lab is a convenient location for testing, it is free, out of the weather and generally at a consistent humidity and temperature. A variety of different surfaces such as bark, grass, gravel, concrete, asphalt, and wood sheeting can all be found and is readily available on campus, these will be used to simulate the competition course. Card board boxes, 2x4 and a bottle jack will be used to make a platform of adjustable height, to test vehicle drops from different levels. A measuring tape will be needed to measure obstacle lengths and heights. Calipers will be used to measure the amount of travel of the steering. The following is an overview of testing procedures:

1. To test the ability of the shocks to dampen the force developed in a 24” drop without any parts failing, the vehicle will be dropped from a measured height. The vehicle must have its weight recorded as well as all of the heights as well. The test is pass/fail. If all systems on the vehicle operate after the drop than it is a pass if there is failure then it is a fail.
2. To determine if the vehicle is interacting with the track surface upon impact after a 24” drop the bottom of the vehicle will be brushed with a surface stain. The vehicle will then be dropped from 24” onto a clean paper surface. The surface stain will mark the clean paper and indicate if the vehicle is contacting the surface after the impact. This test is pass/fail.
3. To test the vehicles ability to climb over a 1.5” height differential. A 2x4x1.5 piece of lumber will be weighted to the floor in the Hogue fluke lab and the vehicle will attempt to climb over the obstacle. The test is pass/fail. If the suspension articulates the desired 1.5 inches and the vehicle is able to climb over the obstacle then the test is a pass if not a fail.
4. To test the vehicles ability to drive in a predictable matter a straight lane 12’ wide and 25 feet long will be outlined in masking tape on the FLUKE lab floor. The vehicle will be placed in the center of the lane and will have to drive from on end to the other without steering and without driving outside of lane, or otherwise deviating more than 6” off course either of which will be considered failing the test.

5. To test the turning radius an arc with a 50" Radius will be outlined on the FLUKE lab floor in masking tape. The vehicle will have to complete a turn without exceeding the radius of the turn. The test is pass/fail, if vehicle stays within outlined arc it is a pass.

The bulk of our testing is pass or fail, and our device is not very precise so a measuring tape should provide sufficient precision for the bulk of our testing. Data will be recorded on green sheets and then uploaded to customized test result sheets, which will then be used to present the data. Those test result sheets will then be stored online via the CWU's student drives.

*Formal Test Procedures:*

1. *Shock Dampening test/ Bottom-out Test (tests 1 and 2 from overview above)*

Location: Hogue technology fluke lab.

- ✓ Step 1: Record Mass of vehicle, and drop heights.
- ✓ Step 2: Place carbon paper at vehicle landing zone (this will test to see if vehicle bottoms out during drop).
- ✓ Step 3: Mark 12", 18", and 24" heights on wall, mark locations with masking tape.
- ✓ Step 4: Drop vehicle from lowest height 1<sup>st</sup>, then drive to ensure all components still are operational. Record if vehicle is unharmed and system components are functional.
- ✓ Step 5: Record if there was interference with carbon paper at landing area (ie bottoming out)
- ✓ Step 6: Repeat steps 4 and 5 with greater heights.

Risk (safety) : Little risk of safety issues, but to be sure wear safety glasses during drop test should any components come flying off of vehicle.

2. *1.5" Obstacle test( #3 from overview above)*

Location: Hogue technology fluke lab.

- ✓ Step 1: Place a 2x4 (standard 2x4 is approximately 1.5" tall) on floor of lab.
- ✓ Step 2: Weight 2x4 so that it will not move, when the vehicle drives over it.  
(A person standing on each side of it will be sufficient)
- ✓ Step 3: Attempt to drive vehicle over 2x4.
- ✓ Step 4: Record if vehicle is successful or not.

Risk (safety): Little risk of safety issues, be sure to keep balance while standing on 2x4.

3. *Vehicle predictability & Straightness test (tests 4 from overview above)*

Location: Hogue technology fluke lab.

- ✓ Step 1: Outline a 12" wide 25' long lane on lab floor in masking tape.

- ✓ Step 2: Place vehicle in center of lane at one end.
- ✓ Step 3: Straighten wheels so that they are not turning in one direction or the other.
- ✓ Step 4: Depress acceleration but do not touch steering wheel, until the vehicle veers out of lane or it reaches the end.
- ✓ Step 5: Record if test was successful, if unsuccessful record location of veering out of lane.  
(Success is determined by the vehicle making it to the end of the lane without veering 6" in either direction.)
- ✓ Step 6: Repeat steps 4-5 five times to determine an average operating predictability.

Risk (safety) : Little risk of safety issues, but to be sure to be wary of runaway vehicles.

To test the turning radius an arc with a 50" Radius will be outlined on the FLUKE lab floor in masking tape. The vehicle will have to complete a turn without exceeding the radius of the turn. The test is pass/fail, if vehicle stays within outlined arc it is a pass.

#### 4. Turning radius Test (tests 5 from overview above)

Location: Hogue technology fluke lab.

- ✓ Step 1: Mark a starting location on fluke lab floor with masking tape.
- ✓ Step 2: Mark a location 50 inches to either side of start point on fluke lab floor with masking tape.
- ✓ Step 3: Place vehicle centered on starting location.
- ✓ Step 4: Rotate steering all the way to the right.
- ✓ Step 5: Depress accelerator while maintaining full right turn.
- ✓ Step 6: Record if turn was inside or outside of the 50" turn radius, as well as total turn radius for that turn.
- ✓ Step 7: Repeat 3-6 five times to obtain averages.
- ✓ Step 8: Repeat steps 3-7 except turning vehicle to the left.

Risk (safety): Little risk of safety issues.

#### Deliverables:

Deliverables				
Test	Calculated Value	Actual Parameter Value	Success Criteria	Pass/Fail
Shock Dampening test/ Bottom-out Test	Support Vehicle	Didn't Bottom Out After 24" Drop	Pass/fail	Pass
1.5" Obstacle test	1.5" Min. Vehicle Travel	Went over all obstacles.	Pass/fail	Pass
Vehicle predictability & Straightness test	Straight Travel over 20ft	Straight Travel Avg. 152"	Straight Travel Avg. 240"	Fail
Turning radius Test	Turn Inside of 50"	Left Avg. Turn radius:72.6" Right Avg:35.5"	Turn radius:< 50" 81	Fail

Figure 52 Sum of deliverables.

The vehicle performed well during the first test which was to determine if the suspension system could support the vehicle. The calculated impulse from the vehicle dropping 24" in was [REDACTED]. Though the test did not determine the actual impulse it did determine that during that impulse the suspension system is functional enough to avoid bottoming out during that drop height and to support the vehicle during normal use.

The second test was the 1.5" static obstacle. This was considered the minimum obstacle size that the vehicle would have to drive over. We determined the overall travel for the front suspension to be 1.67" of travel. Which was greater than the estimated value of 1.5", however it passed this test so easily we then upped the differential to 2" which it also passed.

The third test was to determine straightness of driving and predictability of steering. It was estimated that the sprint course for the competition would be approximately 20ft long, so that was the target distance for a straight away drive length, and the target was to have a less than six inches of deviation during that 20 ft.

**Conclusion:**

**Appendix: Section I Testing Sheets & Testing Schedule**

		Spring (weeks)										
Spring Schedule		1	2	3	4	5	6	7	8	9	10	Finals
Testing Course slalom and speed	Test the Slalom/Speed capabilities of Baja Car	■										
Testing Drop Test	Drop Baja Car to test suspension capabilities	■										
Testing Terrain	Test vehicle in different conditions and terrain	■										
Fix Vehicle					■							
Staight Path Test					■							
Competition	Compete in competition		◁									
Update webpage/Testing Doc							■	■				
Source Presentaion	Prepare a source poster and present							■				
Project End	Finish Whoo hoo											■ End

Figure 53 Updated Schedule

Michael Cox

MET 495c

ASME Mini-Baja Car (steering and suspension)

Testing: Steering Turn Radius

The Purpose of this test is to determine the turn radius of the vehicle.

Target Requirement: <50" Turn Radius

Location: Hogue technology fluke lab.

- Step 1: Mark a starting location on fluke lab floor with masking tape.
- Step 2: Mark a location 50 inches to either side of start point on fluke lab floor with masking tape.
- Step 3: Place vehicle centered on starting location.
- Step 4: Rotate steering all the way to the right.
- Step 5: Depress accelerator while maintaining full right turn.
- Step 6: Record if turn was inside or outside of the 50" turn radius, as well as total turn radius for that turn.
- Step 7: Repeat 3-6 f3 three times to obtain averages.
- Step 8: Repeat steps 3-7 except turning vehicle to the left.

Equipment: Vehicle, remote, masking tape, measuring tape, and camera (documentation).

Risk (safety): Little risk of safety issues.

Steering Radius Test			
Left (in.)		Right (in.)	
73		36	
73		35	
72		35.5	
Average:72.67" Target< 50"	Fail	Average:35.5" Target<50"	Pass

Figure 54 Radius test



Michael Cox

MET 495c

ASME Mini-Baja Car (steering and suspension)

Testing: 1.5 in obstacle

The Purpose of this test is to determine if the vehicle can pass over a static climb of 1.5 (in).

Target Requirement: Pass over obstacle without getting stuck or needing assistance.

**Formal Test Procedures:**

1.5" Obstacle test( #3 from overview above)

Location: Hogue technology fluke lab.

- ✓ Step 1: Place a 2x4 (standard 2x4 is approximately 1.5" tall) on floor of lab.
- ✓ Step 2: Weight 2x4 so that it will not move, when the vehicle drives over it.  
(A person standing on each side of it will be sufficient)
- ✓ Step 3: Attempt to drive vehicle over 2x4.
- ✓ Step 4: Record if vehicle is successful or not.

Risk (safety): Little risk of safety issues, be sure to keep balance while standing on 2x4.

**Results:**

Differential Height (in.)	over obstacle (y/n)	Pass/Fail
1.5	y	Pass
1.5	y	Pass
1.5	y	Pass
1.5	y	Pass
1.5	y	Pass
2	y	Pass
2	y	Pass
2	y	Pass
2	y	Pass
2	y	Pass
Total overall Score		Pass

Figure 55 obstacle test

Michael Cox

MET 495c

ASME Mini-Baja Car (steering and suspension)

Testing: Drop test

The Purpose of this test is to determine if the vehicle will bottom out from a specified drop height.

Target Requirement: No bottom out when dropped from 24+ in.

Formal Test Procedures:

1. Shock Dampening test/ Bottom-out Test (tests 1 and 2 from overview above)

Location: Hogue technology fluke lab.

- ✓ Step 1: Record Mass of vehicle, and drop heights.
- ✓ Step 2: Place carbon paper at vehicle landing zone (this will test to see if vehicle bottoms out during drop).
- ✓ Step 3: Mark 12", 18", and 24" heights on wall, mark locations with masking tape.
- ✓ Step 4: Drop vehicle from lowest height 1<sup>st</sup>, then drive to ensure all components still are operational. Record if vehicle is unharmed and system components are functional.
- ✓ Step 5: Record if there was interference with carbon paper at landing area (ie bottoming out)
- ✓ Step 6: Repeat steps 4 and 5 with greater heights.

Risk (safety) : Little risk of safety issues, but to be sure wear safety glasses during drop test should any components come flying off of vehicle.

Results:

Drop Height (in.)	Bottom out (y/n)	Pass/Fail
18	n	P
24	n	P
30	n	P
Total overall Score		Pass

Figure 56 Drop Test.

Michael Cox

MET 495c

ASME Mini-Baja Car (steering and suspension)

Testing: Straight away Test

The Purpose of this test is to determine if the vehicle will drive straight over a 20ft length with <6 (in) of deviation from a straight line without assistance from driver.

Target Requirement: Drive 20ft. without deviating 6" in either direction.

Formal Test Procedures:

Location: Hogue technology fluke lab.

- ✓ Step 1: Outline a 12" wide 25' long lane on lab floor in masking tape.
- ✓ Step 2: Place vehicle in center of lane at one end.
- ✓ Step 3: Straighten wheels so that they are not turning in one direction or the other.
- ✓ Step 4: Depress acceleration but do not touch steering wheel, until the vehicle veers out of lane or it reaches the end.
- ✓ Step 5: Record if test was successful, if unsuccessful record location of veering out of lane.  
(Success is determined by the vehicle making it to the end of the lane without veering 6" in either direction.)
- ✓ Step 6: Repeat steps 4-5 five times to determine an average operating predictability.

Risk (safety): Little risk of safety issues, but to be sure to be wary of runaway vehicles.

Results:

Straight Away TEST		
Trial	Length (in.)	Pass/fail
1	88	Fail
2	113	Fail
3	240	Pass
4	128	Fail
5	240	Pass
6	73	Fail
7	123	Fail
8	240	Pass
9	146	Fail
10	129	Fail
Avg.	152	Fail

Figure 57 Straight away test