

UNCLASSIFIED

AD NUMBER
AD887548
NEW LIMITATION CHANGE
TO Approved for public release, distribution unlimited
FROM Distribution authorized to U.S. Gov't. agencies only; Test and Evaluation; AUG 1971. Other requests shall be referred to Air Force Weapons Laboratory, Attn: DEZ, Kirtland AFB West, NM 87117.
AUTHORITY
AFWL ltr, 24 Aug 1973

THIS PAGE IS UNCLASSIFIED

2

# SILICATE TREATMENT TO INHIBIT CORROSION OF HOT, POTABLE WATER SYSTEMS, PHASE I

R. W. Lane      C. H. Neff      S. W. Schilsky  
Illinois State Water Survey

AD887548



TECHNICAL REPORT NO. AFWL-TR-71-58

August 1971

**AIR FORCE WEAPONS LABORATORY**  
Air Force Systems Command  
Kirtland Air Force Base  
New Mexico

D D C  
RECEIVED  
AUG 17 1971  
RECEIVED  
A

Distribution limited to US Government agencies only because test and evaluation information is discussed in the report (August 1971). Other requests for this document must be referred to AFWL (DEZ), Kirtland AFB West, NM, 87117.

1086 #6

LEG FILE COPY

AIR FORCE WEAPONS LABORATORY  
Air Force Systems Command  
Kirtland Air Force Base  
New Mexico 87117

When US Government drawings, specifications, or other data are used for any purpose other than a definitely related Government procurement operation, the Government thereby incurs no responsibility nor any obligation whatsoever, and the fact that the Government may have formulated, furnished, or in any way supplied the said drawings, specifications, or other data, is not to be regarded by implication or otherwise, as in any manner licensing the holder or any other person or corporation, or conveying any rights or permission to manufacture, use, or sell any patented invention that may in any way be related thereto.

This report is made available for study with the understanding that proprietary interests in and relating thereto will not be impaired. In case of apparent conflict or any other questions between the Government's rights and those of others, notify the Judge Advocate, Air Force Systems Command, Andrews Air Force Base, Washington, DC 20331.

DO NOT RETURN THIS COPY. RETAIN OR DESTROY.

WHITE SECTION   
BUFF SECTION   
... GEN ...  
...  
... AVAILABILITY CODES ...  
... APPL. and/or SPECIAL ...  
B

DOCUMENT CONTROL DATA - R & D

(Security classification of title, body of abstract and indexing annotation must be entered when the overall report is classified)

1. ORIGINATING ACTIVITY (Corporate author) Illinois State Water Survey Urbana, Illinois 61801		2a. REPORT SECURITY CLASSIFICATION UNCLASSIFIED	
2b. GROUP			
3. REPORT TITLE SILICATE TREATMENT TO INHIBIT CORROSION OF HOT, POTABLE WATER SYSTEMS, PHASE I			
4. DESCRIPTIVE NOTES (Type of report and inclusive dates) March 1969-December 1970			
5. AUTHOR(S) (First name, middle initial, last name) R. W. Lane; C. H. Neff; S. W. Schilsky			
6. REPORT DATE August 1971	7a. TOTAL NO. OF PAGES 106	7b. NO. OF REFS 14	
8a. CONTRACT OR GRANT NO. F29601-69-C-0071	9a. ORIGINATOR'S REPORT NUMBER(S) AFWL-TR-71-58		
b. PROJECT NO. 683JM	9b. OTHER REPORT NO(S) (Any other numbers that may be assigned this report)		
c. Task No. 5	d.		
10. DISTRIBUTION STATEMENT Distribution limited to US Government agencies only because test and evaluation information is discussed in the report (August 1971). Other requests for this document must be referred to AFWL (DEZ), Kirtland AFB West, NM, 87117.			
11. SUPPLEMENTARY NOTES		12. SPONSORING MILITARY ACTIVITY AFWL (DEZ) Kirtland AFB West, NM 87117	
13. ABSTRACT (Distribution Limitation Statement B) Research has been conducted to determine the variables involved in the use of the sodium silicate treatment technique and in the design of a system which utilizes or controls these variables for the efficient control of corrosion of steel, galvanized steel, and copper piping exposed to hot, potable water. Test loops were designed and constructed at nine selected sites to investigate the influence that temperature flow velocity, water chemistry, and silicate formulation and dosage have on the effectiveness of sodium silicate as a corrosion inhibitor for steel, galvanized steel, and copper piping exposed to heat (140°F and 180°F) in aggressive, potable water of four different compositions. Recommendations are made to conduct further research to determine (1) silicate treatment variables involved in treating low alkalinity and low hardness water; (2) the practicality of employing silicate treatment of hard water; (3) the effectiveness of zinc salts as a supplement to silicate; and (4) the corrosion resistance of ASTM A-268 Grade 409 stainless steel.			

14. KEY WORDS	LINK A		LINK B		LINK C	
	ROLE	WT	ROLE	WT	ROLE	WT
Civil engineering Corrosion prevention Hot, potable water corrosion inhibitors						

AFWL-TR-71-58

SILICATE TREATMENT TO INHIBIT CORROSION  
OF HCT, POTABLE WATER SYSTEMS, PHASE I

R. W. Lane      C. H. Neff  
S. W. Schilsky  
Illinois State Water Survey

TECHNICAL REPORT NO. AFWL-TR-71-58

Distribution limited to US Government agencies only because test and evaluation information is discussed in the report (August 1971). Other requests for this document must be referred to AFWL (DEZ), Kirtland AFB West, NM, 37117.

FOREWORD

This report was prepared by the Illinois State Water Survey, Urbana, Illinois, under Contract F29601-69-C-0071. The research was performed under Program Element 63723F, Project 683JM, Task 5.

Inclusive dates of research were March 1969 through December 1970. The report was submitted 30 July 1971 by the Air Force Weapons Laboratory Project Officer, Lt Colonel D. S. Morrisey (DEZ). The former project officer was Captain B. F. Ruggles (DEZ).

The authors wish to acknowledge the important role contributed by Dr. F. W. Sollo in the design and construction of the corrosion tester for measuring polarization resistance and in the supervision and assistance given in the screening corrosion testing. Also the authors wish to acknowledge the advice and guidance given by Dr. T. E. Larson in conducting this research.

This technical report has been reviewed and is approved.

*Doctor D. Morrisey*  
D. S. MORRISEY  
Lt Colonel, USAF  
Project Officer

*Clarence E. Teske*  
CLARENCE E. TESKE  
Lt Colonel, USAF  
Chief, Aerospace Facilities  
Branch

*Jean M. Marchand*  
JEAN M. MARCHAND  
Lt Colonel, USAF  
Chief, Civil Engineering Research  
Division

ABSTRACT

(Distribution Limitation Statement B)

Research has been conducted to determine the variables involved in the use of the sodium silicate treatment technique and in the design of a system which utilizes or controls these variables for the efficient control of corrosion of steel, galvanized steel, and copper piping exposed to hot, potable water. Test loops were designed and constructed at nine selected sites to investigate the influence that temperature, flow velocity, water chemistry, and silicate formulation and dosage have on the effectiveness of sodium silicate as a corrosion inhibitor for steel, galvanized steel, and copper piping exposed to heat (140°F and 180°F) in aggressive, potable water of four different compositions. Recommendations are made to conduct further research to determine (1) silicate treatment variables involved in treating low alkalinity and low hardness water; (2) the practicality of employing silicate treatment of hard water; (3) the effectiveness of zinc salts as a supplement to silicate; and (4) the corrosion resistance of ASTM A-268 Grade 409 stainless steel.



## CONTENTS

<u>Section</u>		<u>Page</u>
I	INTRODUCTION	1
II	DESIGN OF TESTS AND METHODS OF TESTING	4
III	DISCUSSION OF RESULTS	7
IV	CONCLUSIONS AND RECOMMENDATIONS	14
	APPENDIXES	
	I. Design of Corrosion Test Assemblies	16
	II. Corrosion Test Methods	18
	III. Tests on Galvanized Piping	20
	IV. Crevice and Galvanic Corrosion Testing	21
	V. Screening Corrosion Tests	23
	VI. Typical Sodium Silicate Water Treating System	26
	REFERENCES	92
	BIBLIOGRAPHY	93

## ILLUSTRATIONS

<u>Figure</u>		<u>Page</u>
1	Basic Corrosion Test Assembly	28
2	Diagrams of Research Corrosion Apparatus, (a) Research Corrosion Test Unit and (b) Corrosion Test Assembly	29
3	Corrosion of Steel, Site A <sub>1</sub> Run I, Soft Water Plus Added Chloride and Sulfate	30
4	Corrosion of Steel, Site A <sub>1</sub> Run II, Soft Water Plus Added Chloride, Sulfate, and 11 ppm Silica, pH 8.0	31
5	Corrosion of Steel, Site A <sub>1</sub> Run III, Blended Hardness Plus Added Chloride, Sulfate, and 11 ppm Silica, pH 8.1	32
6	Corrosion of Steel, Site A <sub>2</sub> Run I, Soft Water Plus Added Chloride and Sulfate	33
7	Corrosion of Steel, Site A <sub>2</sub> Run II, Soft Water Plus Added Chloride, Sulfate, and 20 ppm Silica, pH 8.3	34
8	Corrosion of Steel, Site A <sub>2</sub> Run III, Blended Hardness Plus Added Chloride, Sulfate, 25 ppm Silica, and 2 ppm Tannin, pH 8.2	35
9	Corrosion of Steel and Copper, Site B <sub>1</sub> Run I, Hard Water Plus Added Chloride, Sulfate, 18 ppm Silica, and 5 ppm Polyphosphate	36
10	Corrosion of Steel and Copper, Site B <sub>1</sub> Run II, Hard Water	37
11	Corrosion of Steel and Copper, Site B <sub>1</sub> Run III, Hard Water Plus Added Chloride, Sulfate, and Caustic Soda, pH 8.0	38
12	Corrosion of Steel and Copper, Site B <sub>2</sub> Run I, Hard Water Plus Added Chloride, Sulfate, 18 ppm Silica, and 6 ppm Polyphosphate	39
13	Corrosion of Steel and Copper, Site B <sub>2</sub> Run II, Hard Water	40
14	Corrosion of Steel and Copper, Site B <sub>2</sub> Run III, Hard Water Plus Added Chloride, Sulfate, and Caustic Soda, pH 8.0	41

ILLUSTRATIONS (CONTINUED)

<u>Figure</u>		<u>Page</u>
15	Corrosion of Steel and Copper, Site C <sub>1</sub> Run I, Soft Water	42
16	Corrosion of Steel and Copper, Site C <sub>1</sub> Run II, Blended Hardness, Added 10 ppm Silica, pH 8.0	43
17	Corrosion of Steel and Copper, Site C <sub>1</sub> Run III, Soft Water, Added 6 ppm Silica, and 3.5 ppm Tannin, pH 8.1	44
18	Corrosion of Steel and Copper, Site C <sub>2</sub> Run I, Soft Water	45
19	Corrosion of Steel and Copper, Site C <sub>2</sub> Run II, Blended Hardness, Added 10 ppm Silica, pH 7.8	46
20	Corrosion of Steel and Copper, Site C <sub>2</sub> Run III, Soft Water, Added 6 ppm Silica, and 3.5 ppm Tannin, pH 8.1	47
21	Corrosion of Steel and Copper, Site D <sub>1</sub> Run I, Blended Hardness	48
22	Corrosion of Steel and Copper, Site D <sub>1</sub> Run II, Blended Hardness, Added 22 ppm Silica, pH 8.1	49
23	Corrosion of Steel and Copper, Site D <sub>1</sub> Run III, Blended Hardness, Added 11 ppm Silica, pH 8.1	50
24	Corrosion of Steel and Copper, Site D <sub>2</sub> Run I, Blended Hardness	51
25	Corrosion of Steel and Copper, Site D <sub>2</sub> Run II, Blended Hardness, Added 22 ppm Silica, pH 8.1	52
26	Corrosion of Steel and Copper, Site D <sub>2</sub> Run III, Blended Hardness, Added 11 ppm Silica, pH 8.0	53
27	Corrosion of Steel and Copper, Site E Run I, Blended Hardness	54
28	Corrosion of Steel and Copper, Site E Run II, Blended Hardness, Added 10 ppm Silica, pH 8.1	55
29	Corrosion of Steel and Copper, Site E Run III, Blended Hardness, Added 5 ppm Silica, pH 8.2	56
30	Corrosion of Galvanized Steel, Site A <sub>1</sub> Run I, Soft Water Plus Added Chloride and Sulfate	57

ILLUSTRATIONS (CONTINUED)

<u>Figure</u>		<u>Page</u>
31	Corrosion of Galvanized Steel, Site A <sub>1</sub> Run II, Soft Water Plus Added Chloride, Sulfate, and 11 ppm Silica, pH 8.0	58
32	Corrosion of Galvanized Steel, Site A <sub>1</sub> Run III, Blended Hardness Plus Added Chloride, Sulfate, and 11 ppm Silica, pH 8.1	59
33	Corrosion of Galvanized Steel, Site A <sub>2</sub> Run I, Soft Water Plus Added Chloride and Sulfate	60
34	Corrosion of Galvanized Steel, Site A <sub>2</sub> Run II, Soft Water Plus Added Chloride, Sulfate, and 20 ppm Silica, pH 8.3	61
35	Corrosion of Galvanized Steel, Site A <sub>2</sub> Run III, Blended Hardness, Added 25 ppm Silica, and 2 ppm Tannin, pH 8.2	62
36	Corrosion of Galvanized Steel, Site B <sub>1</sub> Run I, Hard Water Plus Added Chloride, Sulfate, 18 ppm Silica, and 5 ppm Polyphosphate	63
37	Corrosion of Galvanized Steel, Site B <sub>1</sub> Run II, Hard Water	64
38	Corrosion of Galvanized Steel, Site B <sub>1</sub> Run III, Hard Water Plus Added Chloride, Sulfate, and Caustic Soda, pH 8.0	65
39	Corrosion of Galvanized Steel, Site B <sub>2</sub> Run I, Hard Water Plus Added Chloride and Sulfate, 18 ppm Silica, and 6 ppm Polyphosphate	66
40	Corrosion of Galvanized Steel, Site B <sub>2</sub> Run II, Hard Water	67
41	Corrosion of Galvanized Steel, Site B <sub>2</sub> Run III, Hard Water Plus Added Chloride, Sulfate, and Caustic Soda, pH 8.0	68
42	Corrosion of Galvanized Steel, Site C <sub>1</sub> Run I, Soft Water	69
43	Corrosion of Galvanized Steel, Site C <sub>1</sub> Run II, Blended Hardness, Added 10 ppm Silica, pH 8.0	70
44	Corrosion of Galvanized Steel, Site C <sub>1</sub> Run III, Soft Water, Added 6 ppm Silica, and 3.5 ppm Tannin, pH 8.1	71

ILLUSTRATIONS (CONTINUED)

<u>Figure</u>		<u>Page</u>
45	Corrosion of Galvanized Steel, Site C <sub>2</sub> Run I, Soft Water	72
46	Corrosion of Galvanized Steel, Site C <sub>2</sub> Run II, Blended Hardness, Added 10 ppm Silica, pH 7.8	73
47	Corrosion of Galvanized Steel, Site C <sub>2</sub> Run III, Soft Water, Added 6 ppm Silica, and 3.5 ppm Tannin, pH 8.1	74
48	Corrosion of Galvanized Steel, Site D <sub>1</sub> Run I, Blended Hardness	75
49	Corrosion of Galvanized Steel, Site D <sub>1</sub> Run II, Blended Hardness, Added 22 ppm Silica, pH 8.1	76
50	Corrosion of Galvanized Steel, Site D <sub>1</sub> Run III, Blended Hardness, Added 11 ppm Silica, pH 8.1	77
51	Corrosion of Galvanized Steel, Site D <sub>2</sub> Run I, Blended Hardness	78
52	Corrosion of Galvanized Steel, Site D <sub>2</sub> Run II, Blended Hardness, Added 22 ppm Silica, pH 8.1	79
53	Corrosion of Galvanized Steel, Site D <sub>2</sub> Run III, Blended Hardness, Added 11 ppm Silica, pH 8.0	80
54	Corrosion of Galvanized Steel, Site E Run I, Blended Hardness	81
55	Corrosion of Galvanized Steel, Site E Run II, Blended Hardness, Added 10 ppm Silica, pH 8.1	82
56	Corrosion of Galvanized Steel, Site E Run III, Added 5 ppm Silica, pH 8.2	83

TABLES

<u>Table</u>		<u>Page</u>
1	Pertinent Data on Galvanized Steel Specimens	84
2	Pertinent Data on Copper Corrosion Specimens	86
3	Pertinent Data on Crevice and Galvanic Corrosion Specimens	88
4	Analyses of Deposits on Galvanized Steel Specimens	89
5	Summary of Test Conditions and Results, (a) Water Composition, Treatment and Corrosion Test Variables and (b) Hypothetical Combinations of Deposits on Galvanized Steel Specimens	91

## ABBREVIATIONS AND SYMBOLS

ppm	Parts per million
epm	Equivalents per million
ft/sec	Velocity
Test sites	A <sub>1</sub> ,A <sub>2</sub> ,B <sub>1</sub> ,B <sub>2</sub> ,C <sub>1</sub> ,C <sub>2</sub> ,D <sub>1</sub> ,D <sub>2</sub> ,E
A <sub>1</sub> -I-1	Site A <sub>1</sub> , Run I, Circuit 1
X,Y,Z	Different Institutions
AB	Corrosion rate (in MDD) by weight loss (dry weight on removal minus final weight after cleaning)
D	Corrosion rate (in MDD) by weight loss (weight including tight scale minus original weight)
E	Corrosion rate (in MDD) by weight loss (original weight minus the final weight after cleaning)
MDD	Milligrams per square decimeter per day
MPY	Mils penetration per year
SiO <sub>2</sub>	Silica
NaOH	Caustic Soda
Zn	Zinc
Fe	Iron
sl.	Slight
def.	Definite
consid.	Considerable
galv.	Galvanized

SECTION I  
INTRODUCTION

The purpose of this investigation has been to determine the factors involved and to design treatment methods for obtaining greater effectiveness of silicate in treating hot potable waters of varied composition. Corrosion has been a problem in large central hot domestic water systems ever since their inception. Although properly applied silicate treatment has provided an acceptable solution, a complete understanding of the technology involved and the full effectiveness of this method of treatment have not been attained. Experience in the State of Illinois institutions (Ref. 1) had disclosed that sodium silicate (8 ppm added silica) treatment applied to water of blended hardness content of 60-90 ppm and the pH adjustment to 8.2, were effective in controlling the corrosion of galvanized steel and copper in corrosive waters. This study has been designed largely to verify this conclusion and to further investigate variables associated with the corrosion process involved.

Research conducted in closed circulatory systems has not yielded the same corrosive conditions experienced in actual hot water systems in which appreciable make-up water is added continuously to the system. Accordingly, this fact and the cost of the wastage of large volumes of hot water were recognized as important in the designing of the experimental apparatus. The test sites and test equipment were therefore generally designed into actual institutional hot water systems, in which the water and heat losses were considered a part of the cost of the operation of the system and did not need to be considered. It was planned to conduct tests at three Illinois state institutions and at Chanute Air Force Base, Illinois.

In addition, a research unit in which chemicals would be applied that might deleteriously affect a large institutional hot water system was necessary. This smaller unit was designed so that results would be comparable to the large institutional systems and the water wastage and heat losses would be reasonable.



Comparison of the results obtained with this unit and an institutional type test unit in the same water supply was provided at the Chanut Air Force Base and indicated that equivalent results could be obtained with both units.

Past research indicated that the protective deposits in Eastern waters of low hardness and alkalinity content (10-50 ppm) are composed mainly of silica (Ref. 2); whereas protective deposits in the Midwestern waters of high hardness (approximate 10-170 ppm) and of high alkalinity (200-400 ppm) (Ref. 3) are composed mainly of zinc carbonate and zinc oxide.

The influence of velocity in the normal range of 0.5-6 ft/sec had not been studied; also, the effect of various water quality factors (such as hardness, alkalinity, chloride, sulfate, dissolved oxygen, pH, calcium carbonate saturation index, silica, copper, etc.) on the corrosion of steel, galvanized steel, and copper piping required further study. Primarily the concern had been with corrosion at 140°F (the normal temperature of domestic hot water); however, the corrosion of 180°F water, as employed for dishwashing and laundry use, also required study since there was little information on the proper materials or practices for controlling corrosion at this temperature.

The necessity of studying the available methods of determining the corrosivity of water at these temperatures and deciding on the best method was recognized. In addition, the role of crevice and galvanic corrosion in this corrosion process was recognized to be of importance, and development of appropriate test methods was required.

Past research has shown that lengthy tests of 6-24 months were necessary to differentiate between methods of treatment. This meant that few tests could be conducted on the planned systems during the 1-year test period allotted. Accordingly, it was decided that screening type tests should be conducted to determine the most significant tests to run to obtain indicative results within the year period.

The design of a chemical feeding system, based on experience in the Illinois State Institutions, was also to be provided for a typical Air Force installation. This is presented as Appendix VI.

The text of this report includes a brief description of the test design and testing methods, a discussion of the results and recommendations for further research. Details of the test unit assembly and the testing methods used are given in Appendixes I-V; tables of data and illustrations are grouped at the end of the appendix sections.

## SECTION II

### DESIGN OF TESTS AND METHODS OF TESTING

Corrosion test assemblies, as shown in Figures 1 and 2, were located at the following test sites.

<u>Test site</u>	<u>Location</u>	<u>Temperature (°F)</u>
A <sub>1</sub> , A <sub>2</sub>	Chanute Water Plant (research unit)	140, 180
B <sub>1</sub> , B <sub>2</sub>	Chanute Base Exchange (P22)	140, 180
	Lincoln State School Annex	
C <sub>1</sub>	Delivery to system	140
C <sub>2</sub>	Return from system	140
D <sub>1</sub> , D <sub>2</sub>	Dwight State Reformatory	140, 180
E	Pontiac Penitentiary	140

These test sites were chosen because of the different water qualities available at these locations and because of their proximity to the State Water Survey laboratory at Urbana. Specifically, Chanute was chosen because it was an Air Force facility having a hard, blended, and soft water supply for testing. The Lincoln supply was chosen because of its rather high carbon dioxide and its reported corrosiveness to copper and galvanized steel. The Dwight supply was chosen because of its high chloride and sulfate content and its known high degree of corrosiveness to metals. The Pontiac supply was chosen because of its known corrosiveness and because of its being a surface water supply containing high dissolved oxygen.

The research unit, shown in Figure 2, was located at the Chanute Air Force Base Water Plant where untreated well water, blended water, and completely softened water were available for testing. This unit was designed, as described in Appendix I, to provide flow rates, water usage, and metal contact similar to those in large institutional hot water systems.

The test units were designed to include circulatory pumps in order that the effect of constant low to high velocities (0.5-6.0 ft/sec) could be studied.

Since weight loss procedures have received the most acceptance in corrosion rate measurement and since the laboratory had had the most experience with the weight loss method described in ASTM D2688 Method C (Ref. 4), it was decided that this method should be the basic method for the determination of the corrosion rates, as discussed in Appendix II. Need for a continuous instantaneous measurement, such as the linear polarization method described in ASTM D2776 Method B (Ref. 5), was also recognized. Accordingly a portable tester (Ref. 6) was constructed. This method was later shown to lack correlation with actual corrosion occurring in the piping. This is because of the distinct difference in velocity and environment at the probe in the middle of the piping and at the scaled pipe wall. The portable tester did serve a useful function in indicating when the corrosion rate had decreased to a steady constant rate, at which time the tared specimens could be removed to obtain the most pertinent information on the corrosion rate.

Since galvanized pipe had been reported to be nonuniform in galvanizing, the piping used for corrosion testing was tested for zinc content and uniformity of coating (Appendix III). Also a 24-inch length of galvanized piping was included in each run so that results could be compared with the results obtained with the shorter pipe inserts and probes required in the above test methods.

To evaluate galvanic corrosion between copper and steel, test probes of these metals were installed and current measurements were made to determine the galvanic corrosion rate. In addition, alternate 1-inch length copper and galvanized steel inserts were installed in place of the 4-inch inserts used in the ASTM D2688 method. These shorter inserts were connected electrically to provide good contact between the specimens and to ensure a more accurate galvanic corrosion rate.

Crevice corrosion of the galvanized steel inserts was evaluated by exposing unpainted steel areas, as described in Appendix IV.

To determine the optimum pH and the proper preparation of silicate solutions for application in water treatment, screening tests were conducted in the laboratory corrosion testing equipment (Refs. 6,7,8). These tests, described in Appendix V, revealed that equal results were obtained with any one of four solutions: namely, 0.5 or 5.0% solutions of liquid sodium silicate (41° Baume, 28.8% SiO<sub>2</sub>, 9.2% Na<sub>2</sub>O, alkali-silica ratio 1:3.22); preparation by neutralizing the alkalinity with acid and ageing; or preparation by neutralizing the solution by ion exchange. These results seem to be verified by a recent article (Ref. 9) which has disclosed that activated, partially neutralized, or excessively prediluted sodium silicate solutions were not as effective as fresh and concentrated preparations in stabilizing iron solutions or in providing desired characteristics of surface absorption. Surface absorption characteristics (Ref. 10) are considered important in the inhibition of corrosion of potable waters by silicates.

### SECTION III

#### DISCUSSION OF RESULTS

Because of the limited testing time, it has been difficult to develop definite conclusions on the effectiveness of silicate in the different water supplies. Corrosion rates in distribution water piping systems are highly variable in early stages and decrease slowly to a steady rate. The normal piping materials employed must be relatively corrosion resistant because of the high cost of installation and replacement.

In the Illinois State Institutions, piping specimens are normally exposed for at least a 24-month period in order to attain sufficient weight losses for significant corrosion results. Various techniques have been employed to speed up the results, namely:

- (1) Employing relatively high rate corrosive waters.
- (2) Employing polarization methods of corrosion measurement in order to observe when the corrosion rate had reached a steady state.
- (3) Employing steel (the base metal of galvanized steel and a relatively noncorrosion-resistant metal) to determine corrosion results upon perforation of the galvanizing.
- (4) Employing screening corrosion tests in order to learn the most pertinent tests to conduct.

After the study was completed, it was recognized that all water supplies studied were high in alkalinity (200-400 ppm) and that it would have been preferable to have included waters of lower alkalinity (50-200 ppm). This is planned in Phase II of the project which is now under consideration for final approval.

In using the computer in analyzing the test results when corrosion inhibitors were not applied, correlation values of 0.6-0.95 were obtained for the following water quality and mechanical factors when related to corrosion (weight loss) test methods.

<u>Water Quality Variables</u>	<u>Metals</u>
EPM Chloride + Sulfate	Galvanized Steel, Steel, and Copper
Dissolved Oxygen	Steel
Hardness (as CaCO <sub>3</sub> )	Galvanized Steel, Steel, and Copper
Hydrogen Ion	Galvanized Steel, Steel, and Copper
Instantaneous Calcium Carbonate Index (Ref. 11)	Galvanized Steel, Steel
Velocity	Copper

These results were not unexpected since it has been known for some time that these variables are important in determining the corrosion rate of the metals studied.

Further determination of correlation values was less indicative when water treatment variables were included in the program. Analyzing the data in groups composed of waters of similar analysis, velocity, and temperature revealed more information; however, the information desired on actual causative factors was often obscured by conflicting data. Accordingly, careful tabulation of the different corrosion rates obtained by weight loss (as total scale and corrosion products, and tight scale, specifically) has been provided along with the results of the water analyses, the results of inspection of the corrosion specimens, and observations during the tests.

It appears that the corrosion inhibition of galvanized steel in silicate treated water is largely dependent on the amount and uniformity of the zinc and calcium carbonate scale formed on the metal surface. Undoubtedly galvanic corrosion is involved between the zinc and the iron, as well as the intermediate zinc-iron alloy layer, since initial corrosion may indicate numerous small black pits, which apparently do not penetrate to the steel, whereas later the entire surface may acquire a gray-black and generally smooth appearance. Silicate-caustic soda treatment is most effective when partially softened water (about 50-120 ppm hardness) is employed. The formation of zinc carbonate, zinc pyrosilicate, and calcium carbonate on the surface apparently provides the necessary

protective layer to inhibit dissolution of the zinc by carbon dioxide at the lower pH of the untreated water.

Careful examination of the data reveals that liquid silicate is the most effective inhibitor of galvanized steel in high alkalinity aggressive waters, while less aggressive waters (perhaps total chloride and sulfate content below 100 ppm) might be adequately treated with caustic soda by raising the pH to about 8.2. Perhaps the role of silicate is in initially chelating the zinc (iron in Eastern waters) so that a more immediate and continuous protective film is formed in situ instead of the immediate precipitation in the water or the development of a loosely adherent scale.

Reflecting on the three metals involved in this study of inhibition by silicate, it is realized that the mechanisms of inhibition may be entirely different for each. Whereas galvanized steel may depend largely on the formation of a protective layer of basic zinc carbonate for inhibition, it is likely the corrosion of steel would be most effectively inhibited by the formation of a tightly adhering oxide film. Copper which is subject to erosion-corrosion above 3 ft/sec (or lower, at 180°F) may possibly be inhibited at reasonable velocities by high silicate treatment or by the formation of a complete film of calcium carbonate.

Pertinent data obtained at the different sites are revealed in Tables 1-5. Because of the prescribed short test periods and the required long periods for development of steady-state corrosion rates, some of the observed results at first appeared anomalous and could not be verified from corrosion theory and practice. However, with recognition of the importance of bulk scale and corrosion products in inhibiting corrosion of galvanized steel, the importance of determining corrosion rates without complete corrosion product removal and using these values along with total scale and corrosion products in interpretation was recognized. Along with this information, corroboration has been obtained from test observations, the results of inspection of corrosion specimens, and the results of water analyses for corrosion products.



In studying the specific data at the different sites as revealed in Tables 1-5, the following observations and conclusions were made.

(1) Galvanized Steel

With soft water (0-20 ppm hardness) plus added chloride and sulfate at sites A<sub>1</sub>, B<sub>1</sub> (140°F), silicate-caustic soda treatment (as shown in Table 1) provided a lower corrosion rate (AB) and a higher amount of scale and corrosion products (D) than the untreated water test. At 180°F, the corrosion rate was somewhat similar to that at 140°F even though a greater amount of scale was formed. At sites C<sub>1</sub>, C<sub>2</sub>, definite advantage was shown in treating soft water (10-19 ppm hardness) with 6 ppm silicate plus caustic soda to pH 8.1.

With blended hard water (63-77 ppm hardness) at sites D<sub>1</sub> (140°F) and D<sub>2</sub> (180°F), the corrosion rate results did not verify the known advantages of silicate treatment. However, the observed reduced plugging of flow meters with iron corrosion products, the lower iron in the water analyses shown in Table 1, and the known reduced maintenance experienced at this institution by this treatment of highly mineralized water provide evidence that silicate is effective. Greater amounts of scale and corrosion products for the development of a protective film were recorded for the treated water. Therefore, it is expected that a longer test period would be required to show the treatment advantages, particularly since the test location was far removed from the point of treatment application. Also, the low corrosion rate shown for the untreated water test for the first 30 days of exposure confirms the fact that residual inhibition was being provided from past treatment with silicate, resulting in an untreated water test (run I) which was lower than should have been expected. At site E, advantage was shown with 5 ppm silica compared with 10 ppm at equivalent pH.

With hard water (117-179 ppm hardness) plus added chloride and sulfate at sites A<sub>1</sub>, B<sub>1</sub> (140°F) and at A<sub>2</sub>, B<sub>2</sub> (180°F), silicate treated water provided a lower corrosion rate than caustic soda treated water and formed a greater amount of apparently protective scale. The hard water plus chloride and sulfate at sites B<sub>1</sub>, B<sub>2</sub>

treated with polyphosphate and silicate provided a low corrosion rate; however, it is not considered practical to operate with this condition of excessive scale formation.

In reviewing the results of these limited tests, it appears that waters of lower chloride and sulfate content, as C<sub>1</sub>, C<sub>2</sub>, E, were effectively treated with lower silica and caustic soda to pH 8.0; whereas, the waters of higher chloride and sulfate required higher silica at an equivalent pH.

### (2) Steel

As expected, steel was shown to be seriously corroded by all waters studied at 140° and 180°F. It cannot be considered as a suitable material for the waters studied because of its lack of corrosion resistance and the resulting "red water" problems.

No serious attempt has been made to correlate steel corrosion rates with caustic soda-silicate treatment since the degree of corrosion inhibition provided by this treatment was insufficient to make the use of this material practical in the waters studied.

### (3) Copper

In analyzing these results, it was apparent that two different types of corrosion were being encountered, erosion-corrosion at the high flows and dissolution of copper by the natural corrosive factors (carbon dioxide at low pH, high chloride-sulfate, and the lack of a film of calcium carbonate scale) at the lower flows.

In general, the erosion-corrosion at the high flow rates (3.0-5.6 ft/sec) was observed to be more serious at 180°F than at 140°F. Tests in which significant scale development occurred, as hydroxyapatite at B<sub>1</sub>, B<sub>2</sub> runs I, and as calcium carbonate at D<sub>1</sub>, D<sub>2</sub> runs II and III, were most effective in reducing erosion-corrosion. At B<sub>1</sub>, B<sub>2</sub>, runs II and III, considerable evidence of erosion-corrosion was observed because of the lack of formation of a protective scale of calcium carbonate. The practice of applying polyphosphate at the Chanute Water Plant caused the natural scale forming tendency of this blended water to be inhibited. At C<sub>1</sub>, C<sub>2</sub> run III, chestnut tannin, caustic soda, and silicate treatment

provided a thin continuous protective deposit which reduced erosion-corrosion significantly. At site E, the caustic soda-silicate was found to be ineffective, likely because the treated water tests were conducted (Ref. 12) at somewhat higher temperatures and flows and also because of the lack of an adequate calcium carbonate scale layer.

At the low flow rates (0.5 ft/sec), similar observations were made, that is, tests providing significant scale development produced lower corrosion rates. This was again illustrated in the case of B<sub>1</sub>, B<sub>2</sub> run III compared with run II, in which a pH increase provided by caustic soda treatment reduced the corrosion rate and would likely have been even more effective if the polyphosphate treatment employed at the institution had not inhibited the formation of the desired calcium carbonate scale. At site E, 10 ppm silicate seemed to be more effective than 5 ppm silicate at an equivalent pH; however, the higher temperature and flow rate may have influenced this observation. Treated water having a higher calcium carbonate saturation index would likely have been more effective in reducing the corrosion rates at either the low or high flow rates.

#### (4) Crevice Corrosion Specimens

There was generally less crevice corrosion observed at 180°F than at 140°F.

With exception of the B<sub>1</sub>, B<sub>2</sub> run I tests in which excessive scaling occurred, no advantage in caustic soda-silicate treatment was indicated at temperatures of 140° and 180°F at A<sub>1</sub>, A<sub>2</sub>, B<sub>1</sub>, and B<sub>2</sub> sites. Also, at D<sub>1</sub>, D<sub>2</sub>, no treatment advantage was shown at 140° and 180°F.

At C<sub>1</sub>, C<sub>2</sub>, 10 ppm silicate treatment at pH 8.0 in treatment of this blended hardness water provided a decrease in crevice corrosion. At E, 5 ppm silicate treatment at pH 8.2 in treatment of this blended hardness water also provided a decrease in crevice corrosion.

This difference in effectiveness of silicate-caustic soda treatment on crevice corrosion may be explained by the high

chloride and sulfate contents of the waters generally employed at A<sub>1</sub>, A<sub>2</sub>, B<sub>1</sub>, B<sub>2</sub>, D<sub>1</sub>, D<sub>2</sub>. Chloride and sulfate content is known to increase crevice corrosion, so a higher concentration or the use of more effective inhibitors would be required for its control.

(5) Galvanic Corrosion Specimens

There was somewhat less galvanic corrosion observed at 180°F than at 140°F.

Reduced galvanic corrosion resulted from caustic soda treatment at B<sub>1</sub>, B<sub>2</sub>, from 10 ppm silica plus caustic soda treatment (to pH 8.0) of blended hardness water at C<sub>1</sub>, C<sub>2</sub> and at D<sub>1</sub> (140°F), and from 5 ppm silica plus caustic soda treatment (to pH 8.2) of blended hardness water at site E.

Caustic soda-silicate treatment was not effective at D<sub>2</sub> (180°F), where possibly the high temperature and high salt content may be too severe for the concentration of inhibitor employed or the effectiveness of the treatment applied. Also at this temperature, the reversal of the zinc-iron potential may occur and affect the galvanic corrosion process. Increased conductivity as evidenced in the D<sub>1</sub>, D<sub>2</sub> supply is known to increase galvanic corrosion.

Minimal galvanic corrosion was observed at B<sub>1</sub> run I (140°F) in which high hardness and phosphate treatment caused excessive scaling. At 180°F, however, galvanic corrosion was in evidence.

## SECTION IV

### CONCLUSION AND RECOMMENDATIONS

#### 1. Conclusions (for waters of 200-400 ppm alkalinity)

a. For 140°F temperature systems, 4-6 ppm silica with pH adjusted to about 8.0 is effective in reducing corrosion of water of approximately 10-170 ppm hardness and chloride plus sulfate content below 150 ppm. Higher silica (6-10 ppm) is required when the chloride plus sulfate content is above this level.

b. Although a longer test period would have been desirable in determining the (general, pitting, concentrated cell, and galvanic) corrosion rate at 180°F, adequate inhibition is provided at the treatment level of 10-20 ppm silica. Because of the tendency for serious erosion-corrosion of copper to occur at this temperature, galvanized steel may be preferred however adequate silicate treatment must be applied.

c. The corrosion of steel is not effectively inhibited by silicate at dosage levels up to 25 ppm.

d. The erosion-corrosion of copper is observed at flow rates of 3 ft/sec or above, particularly at 180°F. A thick scale layer of calcium carbonate or a continuous protective film produced by caustic soda-silicate-tannin treatment appears to be effective in reducing this corrosion. At lower flow rates, a significant scale layer is also most effective in reducing corrosion apparently caused by carbon dioxide and the chloride and sulfate content of untreated water.

#### 2. Recommendations

a. That steel not be used in hot potable water systems with silicate dosage of 25 ppm or below.

b. That further research be conducted to include the following:

(1) Determination of the silicate treatment variables involved in treating low alkalinity (10-50 ppm) and low hardness (10-50 ppm) waters (as on the East Coast).

(2) Determination of the practicality of employing silicate treatment of hard waters (250 ppm up) with pH adjustment to the 6.5-7.5 range.

(3) Determination of the effectiveness of zinc salts (Ref. 13) as a supplement to silicate.

(4) Determination of the corrosion resistance of ASTM A-268 Grade 409 stainless steel.

## APPENDIX I

### DESIGN OF CORROSION TEST ASSEMBLIES

The corrosion test units were designed to provide three different flow rates of 0.5, 2.0, and 5 ft/sec in the institutional systems at sites B<sub>1</sub>, B<sub>2</sub>, C<sub>1</sub>, C<sub>2</sub>, D<sub>1</sub>, D<sub>2</sub>, and E. The velocities were controlled by installation of a circulating pump and adjustment of valves in the individual circuits.

These test units, shown in Figure 1, are labeled to show the location of the ASTM testers containing steel, galvanized steel, and copper inserts, as well as galvanic and crevice type test inserts. The steel, galvanized steel, and galvanic probes for determining the corrosion rate by linear polarization and the 24-inch pipe specimen are also shown.

In designing the research unit, the central domestic hot water systems in the Illinois State Institutions were studied so that this smaller test assembly would provide approximately the same corrosive conditions experienced in the state systems. Information from these systems and for the research unit is summarized as follows.

	Institutions			Research unit design
	(X)	(Y)	(Z)	
System volume (gal.)	26,000	13,000	1,500	200
Surface area of metal exposed (ft <sup>2</sup> )	18,000	9,000	60	40
Ratio of surface area to capacity (ft <sup>2</sup> /gal.)	0.7	0.7	0.04	0.2
Time required for system volume to circulate (avg. hrs.)	2.9	2.1	No Circula- tion	3.5
Time required for replacement with fresh make-up (hrs.)	4.3	7.2	8.3	8.9
Number of times system volume is replaced daily	5.5	3.3	2.9	2.7

These factors were considered of particular importance in the design of the research unit because fresh water entering the system contains dissolved oxygen and carbon dioxide, important chemical constituents that are usually instrumental in determining and sustaining the corrosion reaction of fresh waters on metals.

The research unit (Figure 2) was designed to limit water wastage because of the cost of water and heat. Flow rates of 1.3, 4.8 and 5.9 ft/sec were obtained by employing 3/8-, 1/2-, and 1-inch piping specimens. Galvanized storage tanks were included to provide the desired ratio of surface area to capacity. In addition, softening, water treating and heating equipment, and means for controlled wastage were provided.



## APPENDIX II

### CORROSION TEST METHODS

Figures 3-56 show the corrosion rate results obtained by the polarization resistance method with steel and galvanized steel probes, by the galvanic method with steel and copper probes, and by weight loss methods in all the corrosion tests conducted at sites A-E. In examining these figures, it should be pointed out that soft water refers to water hardness below 20 ppm, blended water refers to water which has been blended with hard water to provide hardness of 55-120 ppm, hard water refers to waters of 140-285 ppm, and added chloride and sulfate refers to the addition of approximately 100 ppm of chloride and sulfate.

The polarization resistance or linear polarization method is described in ASTM D2776 and by the National Association of Corrosion Engineers committee T-3D-1 (Ref. 14). Three similar steel or galvanized steel electrodes are employed, and the corrosion rate is measured by applying a change in potential (10 mv) between the test and auxiliary test electrodes and measuring the corrosion current between these electrodes while the third freely corroding electrode is employed as the reference electrode. The current flow is then reversed and again measured, and the average of the two corrosion currents is the measured corrosion rate in the system.

The galvanic method consists of two electrodes, one steel and one copper, and includes a 200-ohm resistor in the circuit. The current flow between these two electrodes is considered only as a measure of the relative corrosion rate.

The weight loss method is fully described in ASTM D2688 method C. Corrosion rates for steel obtained by this method are included in Figures 3-29, those for copper in Figures 9-29, and those for galvanized steel in Figures 30-56. To obtain the corrosion rate of copper in MPY, multiply MDD results by 0.161.

In this weight loss procedure, four weighings are made in the test and cleaning procedure; namely, the original weight, the dry weight after removal from the environment, the weight

after removal of loose scale, and the weight after removal of all scale and corrosion products. Certain metals, such as galvanized steel, hold tenaciously to the corrosion products (zinc carbonate), which should possibly not be considered a corrosion loss since this corrosion product may be mainly effective in stifling the corrosion process. Accordingly this value (D) obtained from weight including tight scale minus the original weight is considered a more accurate evaluation of the corrosion rate of galvanized steel than the conventional way of removing all corrosion products. Another value (AB) obtained from dry weight on removal minus final weight after cleaning is considered significant because it measures the total scale and corrosion products covering the metal surface. These values along with corrosion rate (E), obtained from the original weight minus the final weight, have important functions in the diagnosis of this corrosion problem.

Originally it was thought that the results obtained by the linear polarization method would be the main ones employed in reaching the final conclusion; however, when the results from the whole project were completed, it was seen that the weight loss results were more indicative. Inhibition of corrosion is frequently attained by voluminous scale and corrosion products, often soft and thick. The probes of the linear polarization method protrude into the middle of the pipe where such deposits are easily removed from the probes by erosion. This difference may be illustrated by comparing the corrosion rates obtained at the different flow rates by the weight loss and the polarization methods. Reference to Figure 43, illustrating run II at site C<sub>1</sub>, will show that at 90 days weight loss results of galvanized steel increase by 400% from low to high flow, while polarization results increase by only 70%. Variations in flow at the pipe wall are more important in determining the corrosion rate since it is here that the corrosion process is occurring. The flow at the pipe wall is known to be virtually stagnant compared with the flow at the probe and accordingly the difference in corrosion rate measurement obtained by the two test methods should not be unexpected.

### APPENDIX III

#### TESTS ON GALVANIZED PIPING

The analysis and the determination of the uniformity of the zinc coating of 12- to 20-foot lengths of 1-inch schedule 40 galvanized piping (ASTM A120) were conducted to determine their suitability for use as corrosion specimens. In the first test (specimens 1E-9E), 4-inch lengths were taken from the ends (E) and the middle (M) of 3- to 20-foot lengths; in the second test (specimens 12-52), 4-inch lengths were taken from the middle of the remaining nine pipes.

<u>Specimen No.</u>	<u>Zinc</u>		<u>Specimen No.</u>	<u>Zinc</u>	
	<u>oz/ft<sup>2</sup></u>	<u>mils</u>		<u>oz/ft<sup>2</sup></u>	<u>mils</u>
1E	2.15	3.6	12	1.99	3.4
2M	2.07	3.5	17	2.07	3.5
3E	2.16	3.6	22	2.63	4.4
4E	2.14	3.6	27	2.52	4.3
5M	2.10	3.6	32	2.15	3.6
6E	1.40	2.4	37	2.22	3.5
7E	2.08	3.5	42	2.76	4.7
8M	2.42	4.1	47	2.02	3.4
9E	2.00	3.4	52	2.46	4.2

The test method described in the ASTM (A90) method indicated that one 10-foot length represented by specimen 6E should be removed from the lot as being nonrepresentative. The rest of the piping met the ASTM A120 specifications, which call for a minimum of 2 ounces of zinc per square foot, and was therefore used for preparing inserts for the ASTM D2688 method of test and for the 24-inch length specimens.

## APPENDIX IV

### CREVICE AND GALVANIC CORROSION TESTING

In initial crevice corrosion tests (runs I and II), the ends of the short 1- and 2-inch galvanized inserts in the ASTM testers were left unpainted to assimilate threads. The degree of crevice corrosion observed was minimal in these tests; therefore it was concluded that this method of testing apparently did not provide the measure of crevice corrosion desired.

In run III, 1/2-inch length steel inserts were installed between the 1- and 2-inch length galvanized steel specimens. By providing this large crevice area, it seems that a more realistic value of crevice corrosion or a better evaluation of the galvanic corrosion occurring between galvanized steel and steel is provided. Since the zinc (or galvanizing) is largely removed in the pipe threading operation, essentially a combination of a galvanic cell and crevice is provided in the threads. When this larger steel area is employed, the zinc area is probably near the minimum required for providing cathodic protection for steel, and thus a better test of galvanic or crevice corrosion is attained. Therefore it is planned to continue this procedure in future runs.

Crevice corrosion rates obtained by weight loss are included in Table 3 and in Figures 30-56. These tests were conducted at the following velocities.

Site	Velocity (ft/sec)
A <sub>1</sub> ,A <sub>2</sub>	1.3
B <sub>1</sub> ,B <sub>2</sub> ,C <sub>1</sub> ,C <sub>2</sub> ,D <sub>1</sub> ,D <sub>2</sub>	2.0
E	0.5

For galvanic corrosion testing, four short inserts of 1-inch lengths of copper and galvanized steel installed alternately have been employed in the ASTM tester. This assembly of 4-inch overall length fits into the allotted 4-inch space in the plastic sleeve of the ASTM tester. The ends of these short inserts were not painted in order to allow electrical contact in runs I; however, to assure electrical contact, two of the four inserts were

connected with copper strips in runs II and III. In general, this change did not affect the corrosion rates appreciably.

Galvanic corrosion rates obtained by weight loss are included in Table 3 and in Figures 36-56.

## APPENDIX V

### SCREENING CORROSION TESTS

A standard type (Refs. 4,6,8) of corrosion testing apparatus for total-immersion tests, which includes continuous aeration, velocity and pH control was employed in which steel specimens were exposed to a synthetic water of the following composition (similar to Dwight water, D<sub>1</sub>, D<sub>2</sub>):

	<u>ppm</u>		<u>ppm</u>	<u>pH</u>
Calcium (Ca)	16	Alkalinity (CaCO <sub>3</sub> )	275	8.2
Magnesium (Mg)	9	Chloride (Cl)	360	
		Sulfate (SO <sub>4</sub> )	240	

#### Test I

The purpose of this test was to determine whether the concentration, pH, and method of preparation of silicate solutions would affect the corrosion inhibition of steel by silicate.

The solutions tested were:

- Jar 1. 12 ppm silica (SiO<sub>2</sub>) added as 5% solution of N brand sodium silicate.
- Jar 2. 12 ppm silica (SiO<sub>2</sub>) added as 0.5% solution of N brand sodium silicate.
- Jar 3. 12 ppm silica (SiO<sub>2</sub>) added as 5% solution of N brand sodium silicate, neutralized with sulfuric acid, aged 2 hours, added as 0.5% solution.
- Jar 4. 12 ppm silica (SiO<sub>2</sub>) added as 5% solution of N brand sodium silicate, neutralized with sulfuric acid, aged 2 hours, added as 2.5% solution.
- Jar 5. 12 ppm silica (SiO<sub>2</sub>) added as 5% solution of N brand sodium silicate, passed through a hydrogen exchanger, aged 2 hours, added as 5% solution.
- Jar 6. No treatment

Silica concentration was kept within 10% of specified 12 ppm level. Supplemental treatment was required approximately every 10 days. The tests were conducted for 25 days and no appreciable difference in corrosion rate (range of 63-77 MDD by weight loss) was observed between the five differently prepared silicate

solutions. Linear polarization tests gave results approximately 10% higher than weight loss results. The corrosion rate without treatment was 123 MDD (by weight loss), which indicated that the silicate treatment inhibited corrosion in all cases.

Test II

Test I was repeated with the treatment increased to 32 ppm silica in jars 1-5. This test was conducted for 24 days, but no appreciable difference in corrosion inhibition was observed between the silicate solutions. The corrosion rate was at the same level as in test I. Silica concentration was kept within 10% of specified 32 ppm level. Supplemental treatment was required about every 10 days.

Test III

The purpose of this test was to determine whether zinc sulfamate (Ref. 7) increased the inhibition provided by silicate treatment.

The results of the test were as follows:

	pH	Corrosion rate (MDD)			
		Linear polarization		Weight loss	
		43	76	112	136
Jar 1. Steel, no treatment	7.5	80	85	50	45
Jar 2. Steel, 10 ppm SiO <sub>2</sub>	8.2	50	23	18.8	30
Jar 3. Steel, 10 ppm SiO <sub>2</sub> , 3 ppm zinc sulfamate (as Zn)	8.2	15	16	18.0	17
Jar 4. Galv. steel, no treatment	7.5	3	2	7.1	7.5
Jar 5. Galv. steel, 10 ppm SiO <sub>2</sub>	8.2	20	4	5.2	11
Jar 6. Galv. steel, 10 ppm SiO <sub>2</sub> , 3 ppm zinc sulfamate (as Zn)	8.2	3	4	7.4	5.6

This test indicated that the silicate inhibition of the corrosion of steel was increased initially by the addition of zinc sulfamate but on longer exposure no advantage was shown. Silica concentration was kept within 10% of specified 10 ppm level. Zinc precipitated rather rapidly requiring supplemental addition of zinc

sulfate every 2 to 3 days to raise the zinc content from 0.5-1.0 ppm to the specified 3 ppm level. Supplemental addition of silica was required every 10 days.

This method of testing seems to be unsatisfactory for evaluating the small differences in the corrosion of galvanized steel observed with different treatments. In this procedure, the water is changed only every two weeks and, as a result, the accumulation of corrosion products may limit the corrosion rate. Apparently the corrosion of galvanized steel should be investigated under continuous flowing conditions, as in a piping distribution system.



## APPENDIX VI

### TYPICAL SODIUM SILICATE WATER TREATING SYSTEM

An institutional water supply that is corrosive at both cold and hot water temperatures can best be treated as the water is pumped from the well system or as the water enters the institution through a water meter from the city water supply. If only the hot water requires treatment and a central domestic hot water heating system is located in the power plant, proportional treatment can be applied there. If the institution has numerous domestic hot water systems in separate buildings, it will likely prove best to treat the entire supply regardless of the treatment requirements of the cold water.

If the hardness of the supply exceeds 150 ppm, sodium zeolite softeners should be installed to soften the water to the 60-90 ppm level by completely softening the desired percentage of water and blending sufficient hard water to provide 60-90 ppm hardness in the effluent. In waters of appreciable chloride and sulfate content >150-300 ppm, application of liquid sodium silicate (41° Baume, 28.8% SiO<sub>2</sub>, 9.2% Na<sub>2</sub>O, alkali-silica ratio 1:3.22) at 6-10 ppm silica (SiO<sub>2</sub>) plus caustic soda to provide pH of about 8.2 is recommended.

An institution using 500,000 gallons of water per day and having a well supplying 500 gpm would require treatment equipment as follows:

- 1 Electrical connection from well pump magnetic starter to chemical pump magnetic starter to initiate chemical pump operation whenever well pump operates
- 1 Chemical pump starter
- 1 Chemical pump of following specifications: Constant adjustable volume diaphragm pump of corrosion resistant construction to handle chemicals specified, maximum pressure 100 psi, specified capacity of 0-3.0 gph. It should include electric motor and plastic tubing for introduction of chemical solution from vat to discharge point in water line.
- 1 Chemical tank and mixer of the following specifications: 200 gallon tank of polyethylene construction or approved equivalent. An electric mixer which must be sturdily mounted, have a separate electrical switch, and be of proper

corrosion resistant properties to handle chemicals specified.

If metered city water rather than institutional well water is to be treated, then an electriccontact water meter and timer will be necessary to provide proportional chemical feed to the water line. Based on a maximum flow of 500 gpm, a 6-inch meter with electriccontact likely will be required; however, engineering interpretation may be required on the type and size of water meter to obtain since the accuracy of the meter under low and average flows must be given consideration. In addition to the equipment specified previously, the following will be required:

- 1 6-inch electriccontact water meter with electriccontact every 1000 gallons
- 1 Timer, electric, adjustable, 0-15 minute, for initiating chemical pump operation for set number of minutes each time it is actuated by the water meter, for turning off chemical pump and re-setting in order that the chemical pump operation will be actuated the next time that water meter contact is made.

In placing these systems in operation, 20 gallons of the liquid sodium silicate and 100 pounds caustic soda would be dissolved and well mixed in the water (softened, preferably) in the 200 gallon tank. Dosage would be based on the application of 20 gallons of liquid sodium silicate and 50 pounds of caustic soda per 1,000,000 gallons of water or sufficient to apply 8 ppm silica ( $\text{SiO}_2$ ) and to provide a significant pH increase. The quantity of caustic soda required will depend on the alkalinity and pH of the water being treated. The chemical pump would be set at 2 gph if the water meter and timer were not required and would be set at 2.7 gph if the meter and timer were required. In this case the timer would be set at  $1\frac{1}{2}$  minutes to allow 30% of the time interval between meter contacts at 500 gpm flow for re-setting.

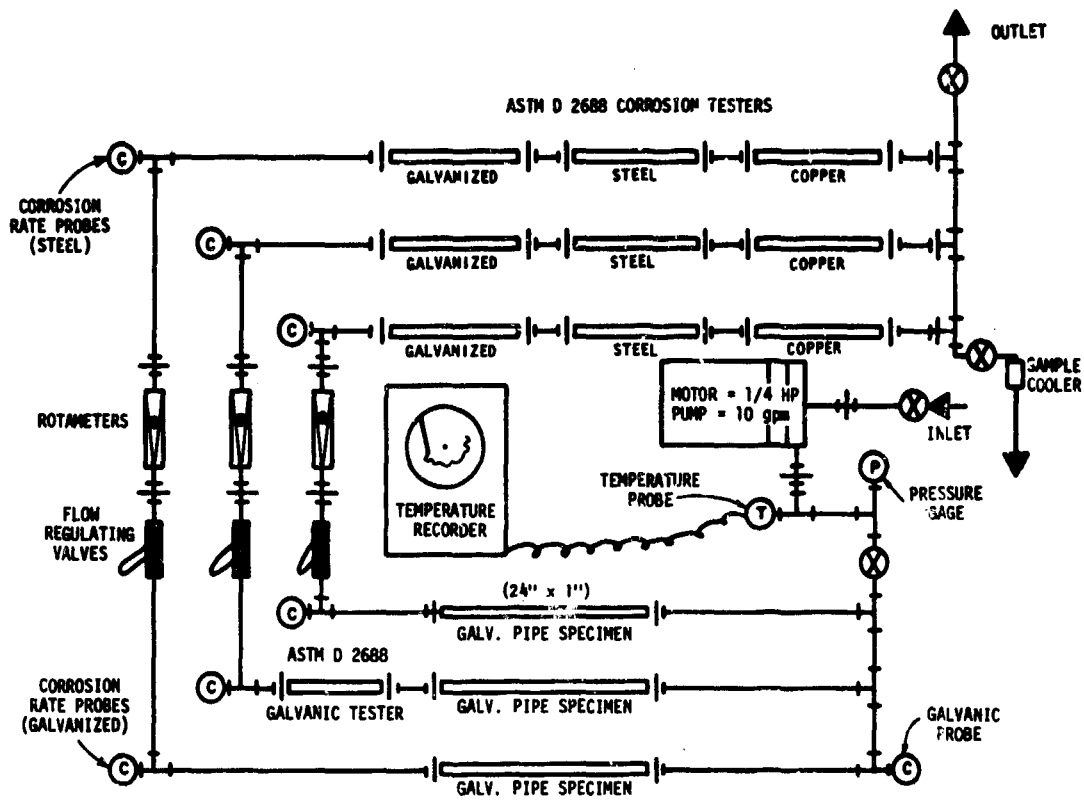
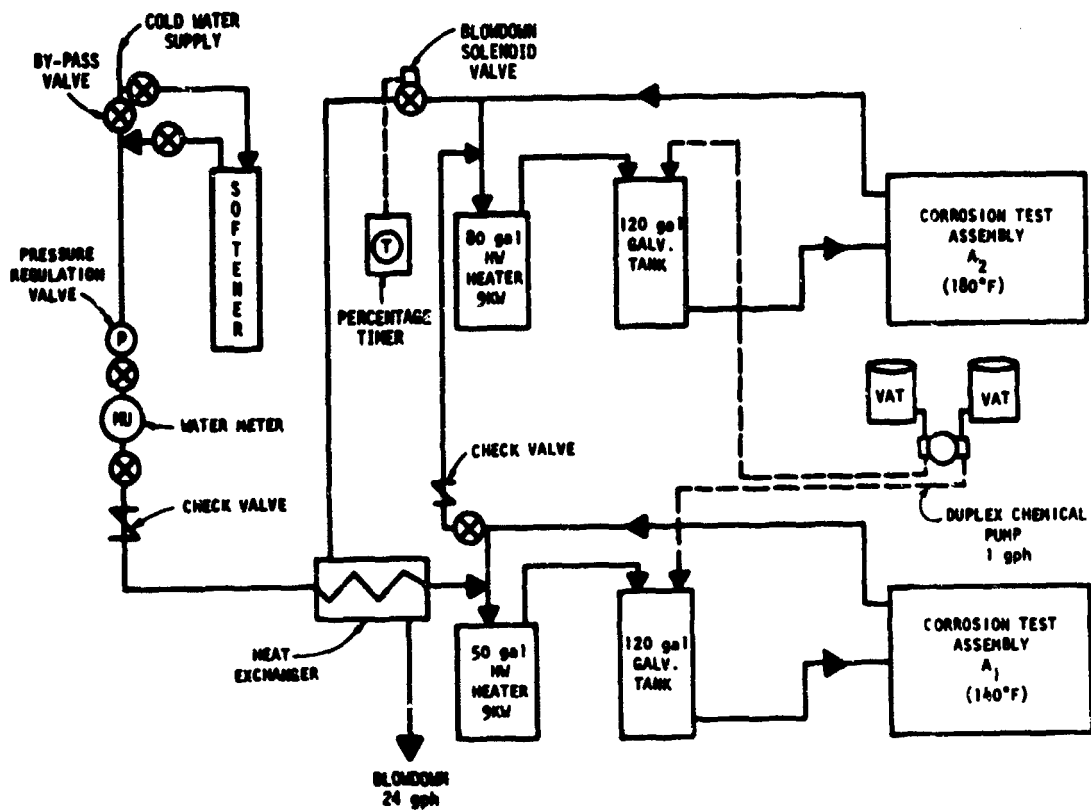
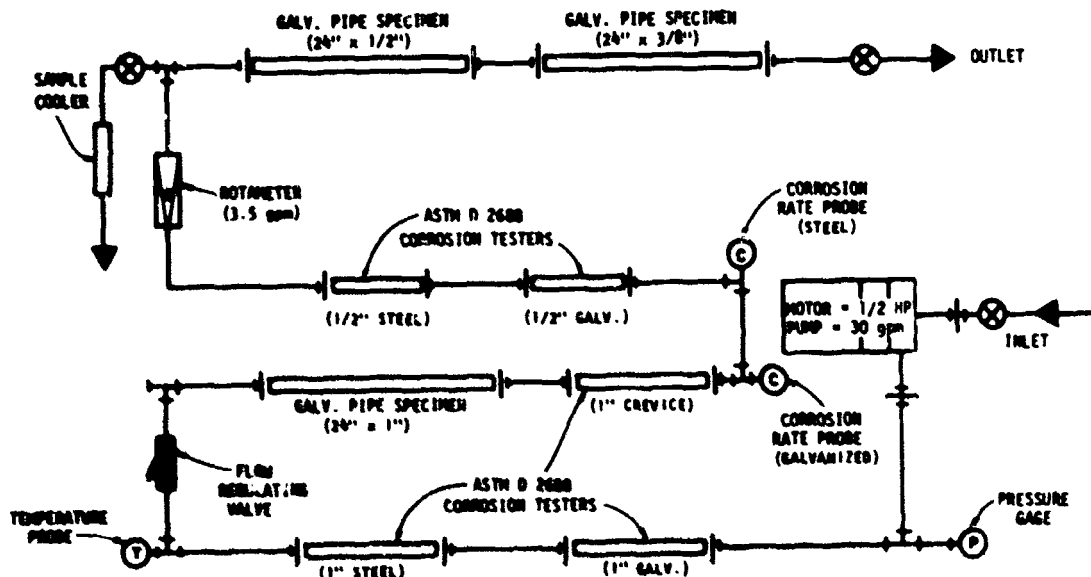

Figure 1. Basic Corrosion Test Assembly



(a) Research Corrosion Test Unit



(b) Corrosion Test Assembly

Figure 2. Diagrams of Research Corrosion Apparatus

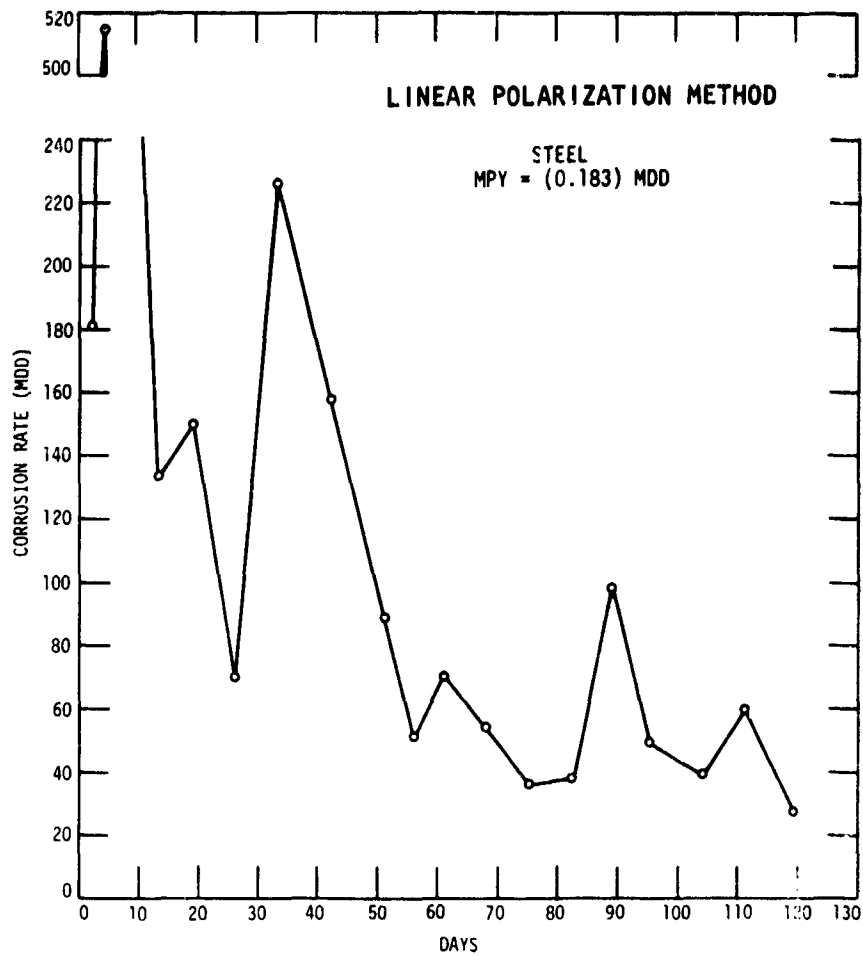

VELOCITY AND DIAMETER	STEEL CORROSION BY WEIGHT LOSS (ASTM, D 2688-C) MDD		
	29 days	90 days	119 days
1" dia 1.3 ft/sec	68	64	50
1/2" dia 4.8 ft/sec	158	55	55

AVERAGE ANALYSIS (ppm)															
Iron (Fe)	Copper (Cu)	Zinc (Zn)	Calcium (Ca)	Magnesium (Mg)	Hardness (as CaCO <sub>3</sub> )	Phosphate (as PO <sub>4</sub> <sup>total</sup> )	Silica (SiO <sub>2</sub> )	Chloride (Cl)	Sulphate (SO <sub>4</sub> )	Nitrate (NO <sub>3</sub> )	Alkalinity (as CaCO <sub>3</sub> )	Dissolved Solids	Dissolved Oxygen	pH	Temperature (°F)
0.5	.02	.60	1.0	0.8	4	0.3	14	112	106	0.8	305	800	1.8	7.6	143

Figure 3. Corrosion of Steel, Site A<sub>1</sub> Run 1, Soft Water Plus Added Chloride and Sulfate

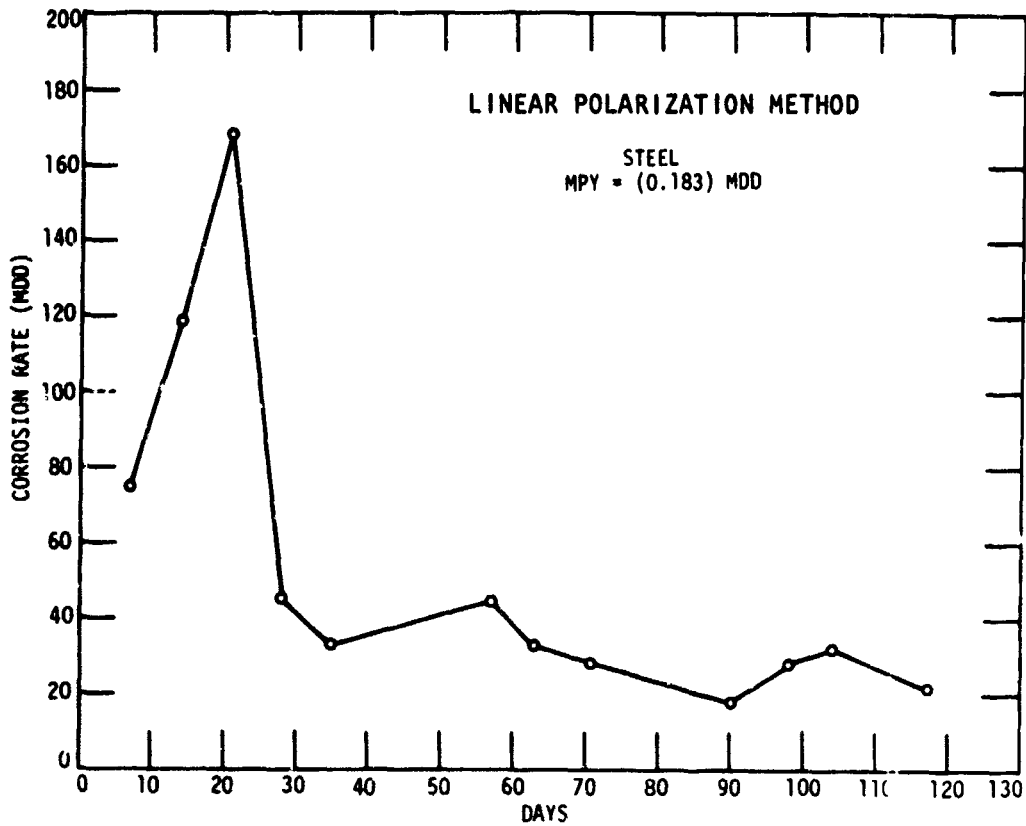

VELOCITY AND DIAMETER	STEEL CORROSION BY WEIGHT LOSS (ASTM, D 2688-C) MDD		
	28 days	93 days	121 days
	1" dia 1.3 ft/sec	150	88
1/2" dia 4.6 ft/sec	105	73	--

AVERAGE ANALYSIS (ppm)															
Iron (Fe)	Copper (Cu)	Zinc (Zn)	Calcium (Ca)	Magnesium (Mg)	Hardness (as CaCO <sub>3</sub> )	Phosphate (as Total)	Silica (SiO <sub>2</sub> )	Chloride (Cl)	Sulfate (SO <sub>4</sub> )	Nitrate (NO <sub>3</sub> )	Alkalinity (as CaCO <sub>3</sub> )	Dissolved Solids	Dissolved Oxygen	pH	Temperature (°F)
0.1	.63	.50	1.0	0.7	3	0.7	23	131	111	0.6	357	667	2.7	8.0	143

Figure 4. Corrosion of Steel, Site A<sub>1</sub> Run II, Soft Water Plus Added Chloride, Sulfate, and 11 ppm Silica, pH 8.0

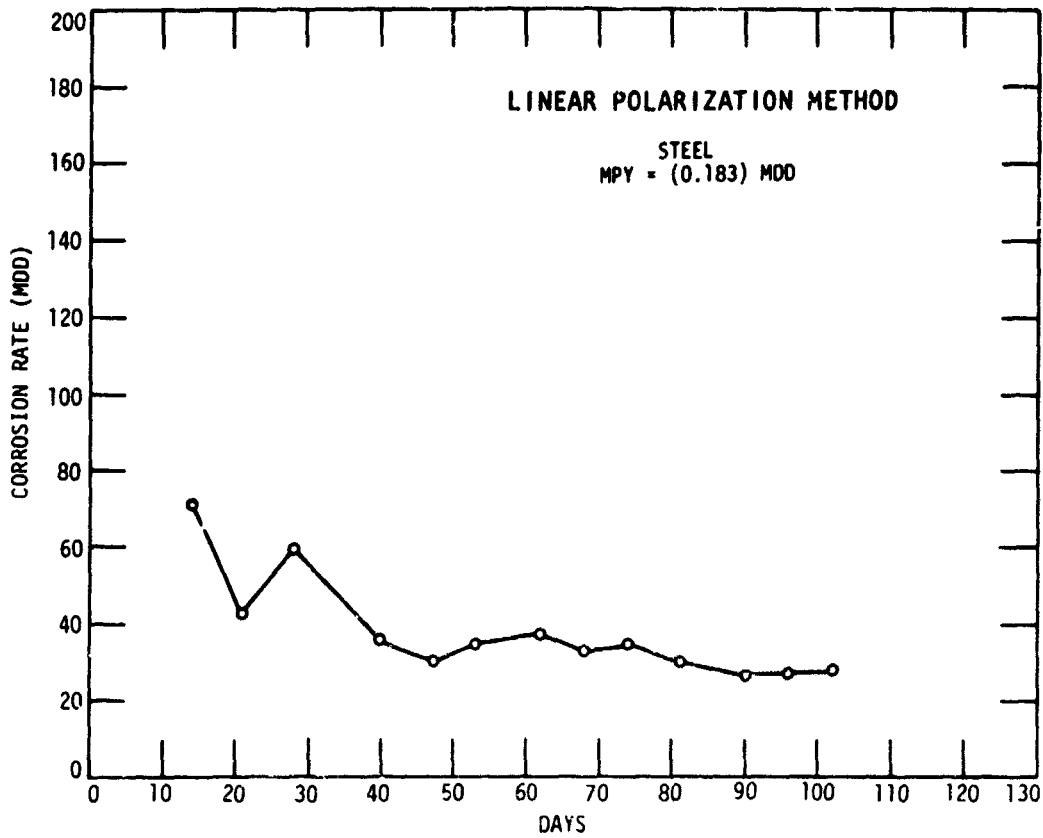

VELOCITY AND DIAMETER	STEEL CORROSION BY WEIGHT LOSS (ASTM, D 2688-C) MDD		
	28 days	74 days	102 days
1" dia 1.3 ft/sec	184	101	68
1/2" dia 4.6 ft/sec	118	63	39

AVERAGE ANALYSIS (ppm)															
Iron (Fe)	Copper (Cu)	Zinc (Zn)	Calcium (Ca)	Magnesium (Mg)	Hardness (as CaCO <sub>3</sub> )	Phosphate (as Total PO <sub>4</sub> )	Silica (SiO <sub>2</sub> )	Chloride (Cl)	Sulphate (SO <sub>4</sub> )	Nitrate (NO <sub>3</sub> )	Alkalinity (as CaCO <sub>3</sub> )	Dissolved Solids	Dissolved Oxygen	pH	Temperature (°F)
0.2	.01	.20	24	12	117	0.6	21	109	94	0.0	338	703	1.7	8.1	137

Figure 5. Corrosion of Steel, Site A<sub>1</sub> Run III, Blended Hardness Plus Added Chloride, Sulfate, and 11 ppm Silica, pH 8.1

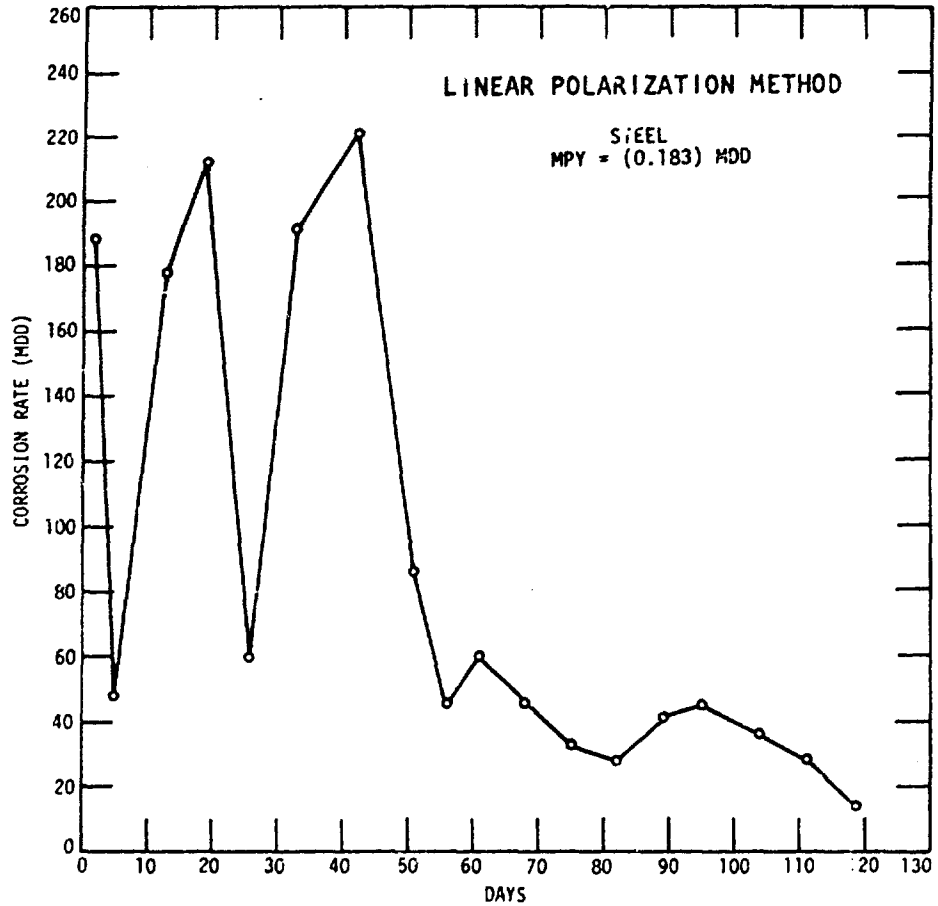

VELOCITY AND DIAMETER	STEEL CORROSION BY WEIGHT LOSS (ASTM, D 2688-C) MDD		
	29 days	90 days	119 days
1" dia 1.3 ft/sec	56	128	98
1" dia 4.8 ft/sec	109	72	49

AVERAGE ANALYSIS (ppm)															
Iron (Fe)	Copper (Cu)	Zinc (Zn)	Calcium (Ca)	Magnesium (Mg)	Hardness (as CaCO <sub>3</sub> )	Phosphate (as Total PO <sub>4</sub> )	Silica (SiO <sub>2</sub> )	Chloride (Cl)	Sulphate (SO <sub>4</sub> )	Nitrate (NO <sub>3</sub> )	Alkalinity (as CaCO <sub>3</sub> )	Dissolved Solids	Dissolved Oxygen	pH	Temperature (°F)
0.6	.02	.63	1.0	0.8	5	0.3	13	116	106	0.7	306	755	0.9	7.7	174

Figure 6. Corrosion of Steel, Site A<sub>2</sub> Run I, Soft Water Plus Added Chloride and Sulfate



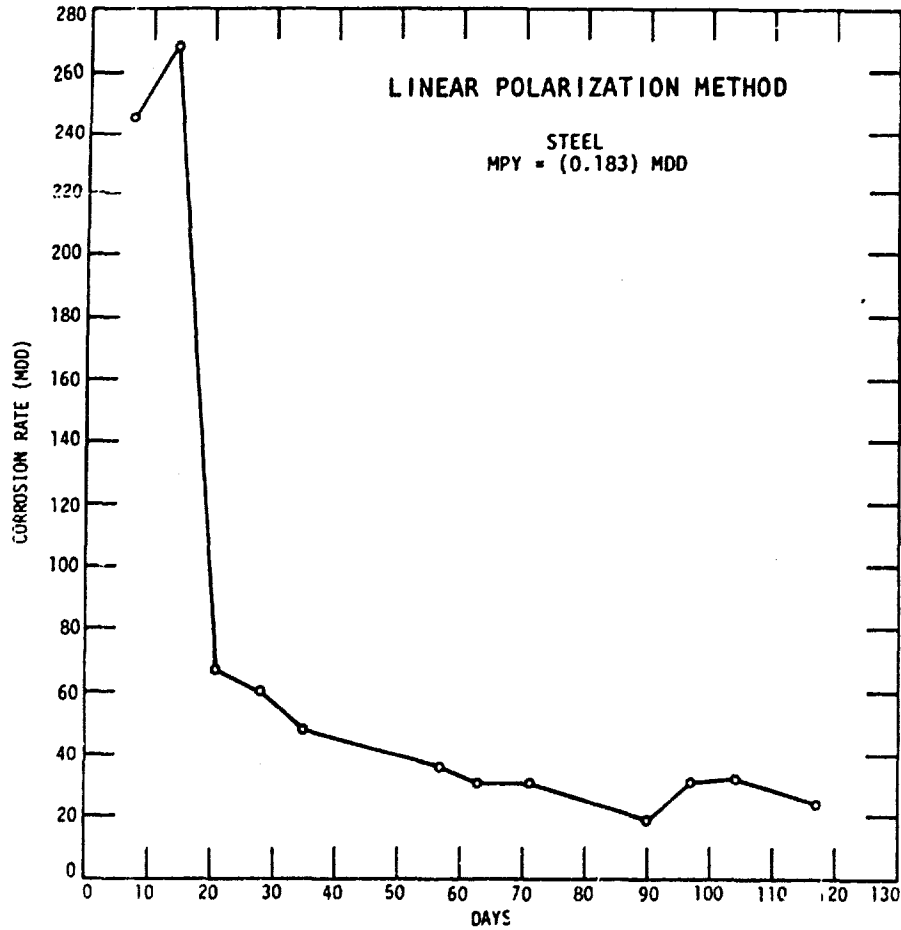

VELOCITY AND DIAMETER	STEEL CORROSION BY WEIGHT LOSS (ASTM, D 2688-C) MDD		
	28 days	93 days	121 days
1" dia 1.3 ft/sec	156	93	63
1/2" dia 4.8 ft/sec	121	66	43

AVERAGE ANALYSIS (ppm)															
Iron (Fe)	Copper (Cu)	Zinc (Zn)	Calcium (Ca)	Magnesium (Mg)	Hardness (as CaCO <sub>3</sub> )	Phosphate (as total P <sub>04</sub> )	Silica (SiO <sub>2</sub> )	Chloride (Cl)	Sulphate (SO <sub>4</sub> )	Nitrate (NO <sub>3</sub> )	Alkalinity (as CaCO <sub>3</sub> )	Dissolved Solids	Dissolved Oxygen	PH	Temperature (°F)
0.4	.02	.34	0.7	0.6	4	0.7	31	115	102	0.7	360	672	1.4	8.3	168

Figure 7. Corrosion of Steel, Site A<sub>2</sub> Run II, Soft Water Plus Added Chloride, Sulfate, and 20 ppm Silica, pH 8.3

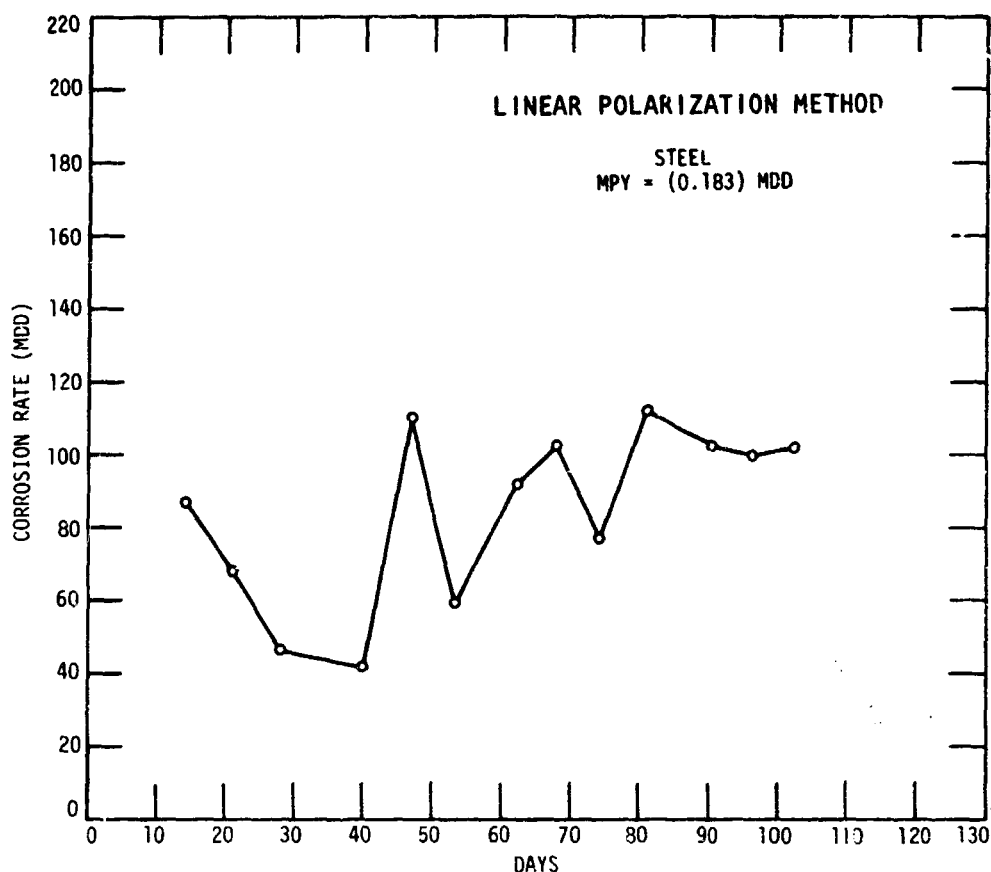

VELOCITY AND DIAMETER	STEEL CORROSION BY WEIGHT LOSS (ASTM, D 2688-C) MDD		
	28 days	74 days	102 days
1" dia 1.3 ft/sec	221	100	115
1/2" dia 4.8 ft/sec	195	55	74

AVERAGE ANALYSIS (ppm)															
Iron (Fe)	Copper (Cu)	Zinc (Zn)	Calcium (Ca)	Magnesium (Mg)	Hardness (as CaCO <sub>3</sub> )	Phosphate (as Total PO <sub>4</sub> )	Silica (SiO <sub>2</sub> )	Chloride (Cl)	Sulphate (SO <sub>4</sub> )	Nitrate (NO <sub>3</sub> )	Alkalinity (as CaCO <sub>3</sub> )	Dissolved Solids	Dissolved Oxygen	pH	Temperature (°F)
0.2	.07	.50	24	13	117	0.6	.37	112	94	0.0	349	715	0.8	8.2	167

Figure 8. Corrosion of Steel, Site A2 Run III, Blended Hardness Plus Added Chloride, Sulfate, 25 ppm Silica, and 2 ppm Tannin, pH 8.2

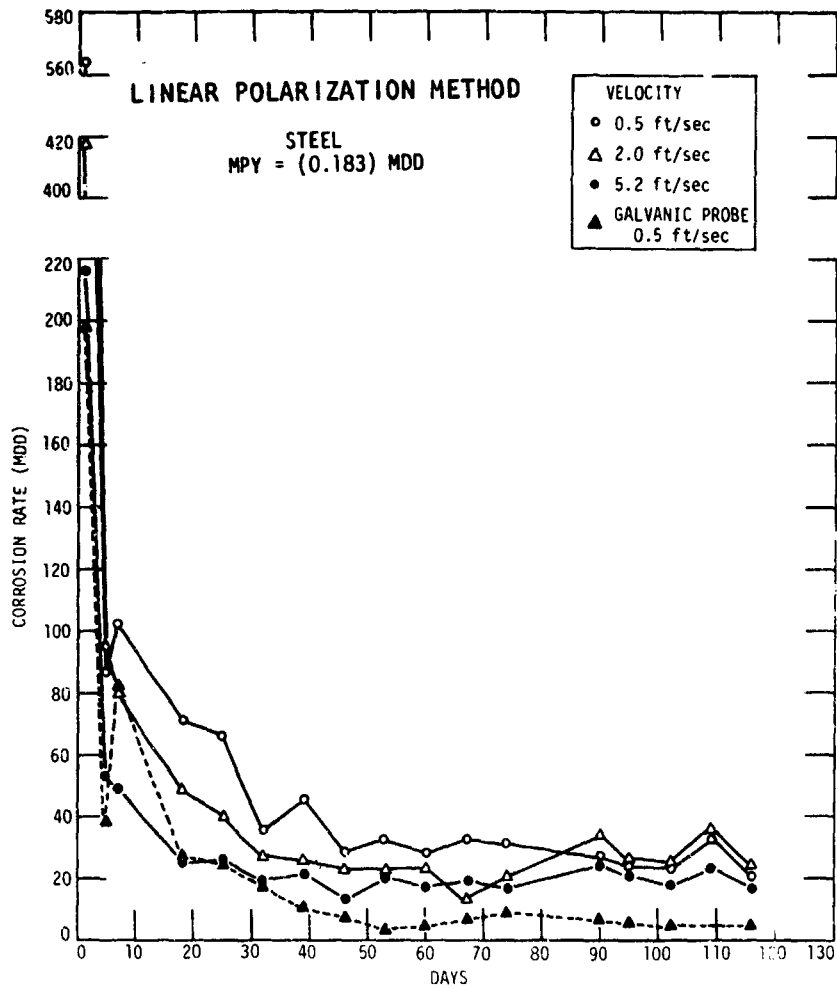

VELOCITY ft/sec	STEEL CORROSION BY WEIGHT LOSS (ASTM, D 2688-C) MDD		
	29 days	91 days	120 days
0.5	75	36	28
2.0	103	48	40
5.2	89	30	31

VELOCITY ft/sec	COPPER CORROSION BY WEIGHT LOSS (ASTM, D 2688-C) MDD		
	29 days	91 days	120 days
0.5	3.5	2.3	2.3
2.0	4.7	2.8	3.9
5.2	5.4	4.9	5.2

AVERAGE ANALYSIS (ppm)												
Iron (Fe)	Copper (Cu)	Zinc (Zn)	Calcium (Ca)	Magnesium (Mg)	Hardness (as CaCO <sub>3</sub> )	Phosphate (as Total PO <sub>4</sub> )	Silica (SiO <sub>2</sub> )	Chloride (Cl)	Sulphate (SO <sub>4</sub> )	Nitrate (NO <sub>3</sub> )	Alkalinity (as CaCO <sub>3</sub> )	Temperature (°F)
1.6	.02	.45	68	26	285	5.1	25	102	105	4.0	348	142

Figure 9. Corrosion of Steel and Copper, Site B<sub>1</sub> Run I, Hard Water Plus Added Chloride, Sulfate, 18 ppm Silica, and 5 ppm Polyphosphate

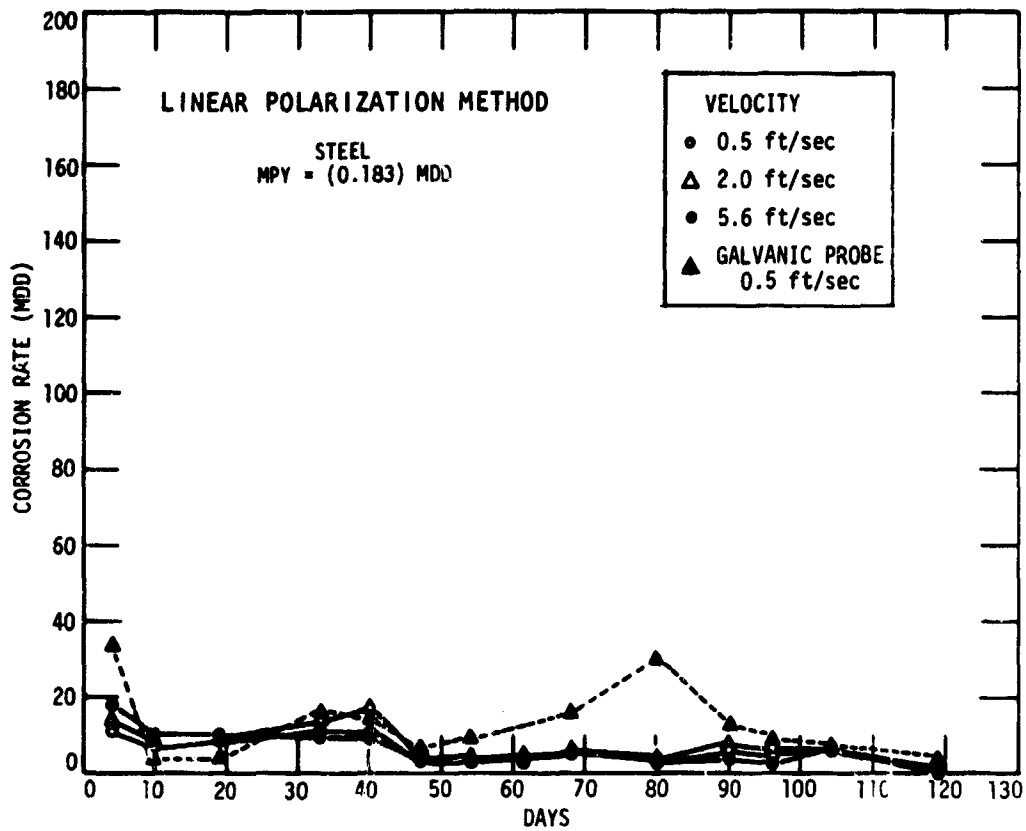

VELOCITY ft/sec	STEEL CORROSION BY WEIGHT LOSS (ASTM, D 2688-C) MDD		
	27 days	92 days	119 days
0.5	49	23	14
2.0	95	—	34
5.6	87	36	29

VELOCITY ft/sec	COPPER CORROSION BY WEIGHT LOSS (ASTM, D 2688-C) MDD		
	27 days	92 days	119 days
0.5	7.4	9.6	8.3
2.0	15	19	17
5.6	21	26	22

AVERAGE ANALYSIS (ppm)															
Iron (Fe)	Copper (Cu)	Zinc (Zn)	Calcium (Ca)	Magnesium (Mg)	Hardness (as CaCO <sub>3</sub> )	Phosphate (as Total PO <sub>4</sub> )	Silica (SiO <sub>2</sub> )	Chloride (Cl)	Sulphate (SO <sub>4</sub> )	Nitrate (NO <sub>3</sub> )	Alkalinity (as CaCO <sub>3</sub> )	Dissolved Solids	Dissolved Oxygen	pH	Temperature (°F)
0.3	.02	.23	26	23	197	0.2	16	4	1	4.5	344	397	4.4	7.7	140

Figure 10. Corrosion of Steel and Copper,  
Site B<sub>1</sub> Run II, Hard Water

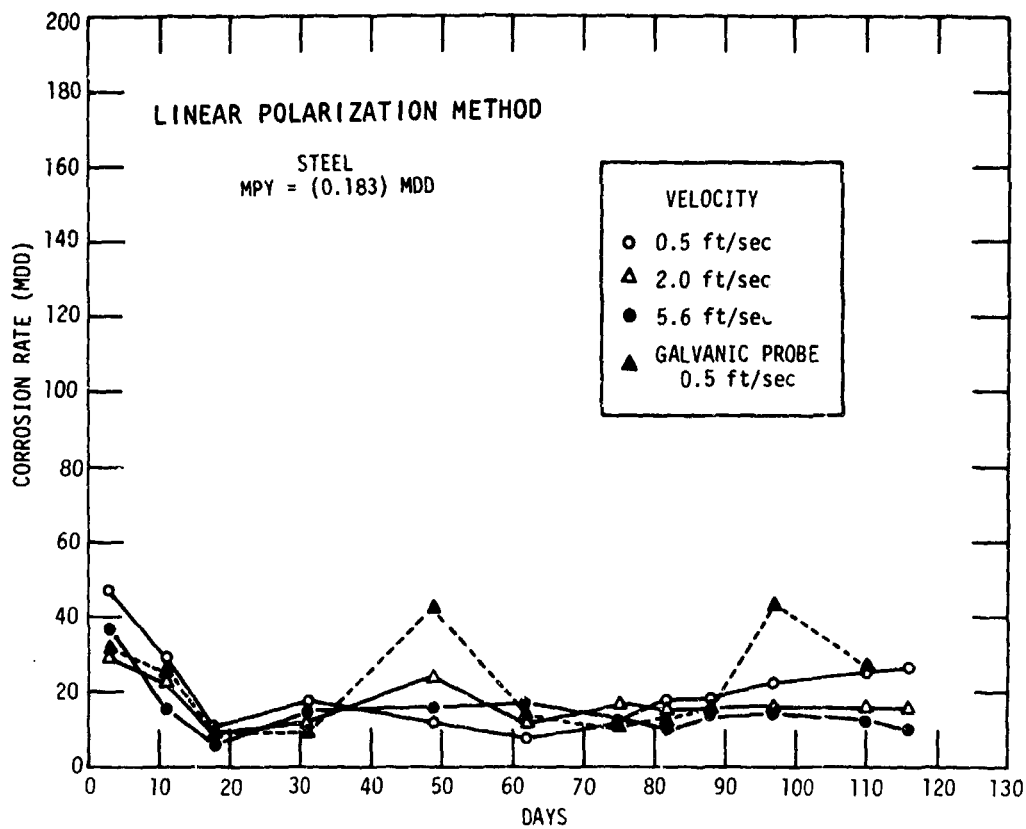

VELOCITY ft/sec	STEEL CORROSION BY WEIGHT LOSS (ASTM, D 2688-C) MDD		
	28 days	94 days	122 days
0.5	78	78	60
2.0	195	77	55
5.6	130	41	42

VELOCITY ft/sec	COPPER CORROSION BY WEIGHT LOSS (ASTM, D 2688-C) MDD		
	28 days	94 days	122 days
0.5	8.2	7.8	6.5
2.0	16	37	26
5.6	22	47	42

AVERAGE ANALYSIS (ppm)															
Iron (Fe)	Copper (Cu)	Zinc (Zn)	Calcium (Ca)	Magnesium (Mg)	Hardness (as CaCO <sub>3</sub> )	Phosphate (as Total P <sub>04</sub> )	Silica (SiO <sub>2</sub> )	Chloride (Cl)	Sulphate (SO <sub>4</sub> )	Nitrate (NO <sub>3</sub> )	Alkalinity (as CaCO <sub>3</sub> )	Dissolved Solids	Dissolved Oxygen	pH	Temperature (°F)
0.5	0.03	17	33	18	140	1.4	14	96	85	3.4	367	669	5.7	8.0	141

Figure 11. Corrosion of Steel and Copper, Site 3<sub>1</sub> Run III, Hard Water Plus Added Chloride, Sulfate, and Caustic Soda, pH 8.0

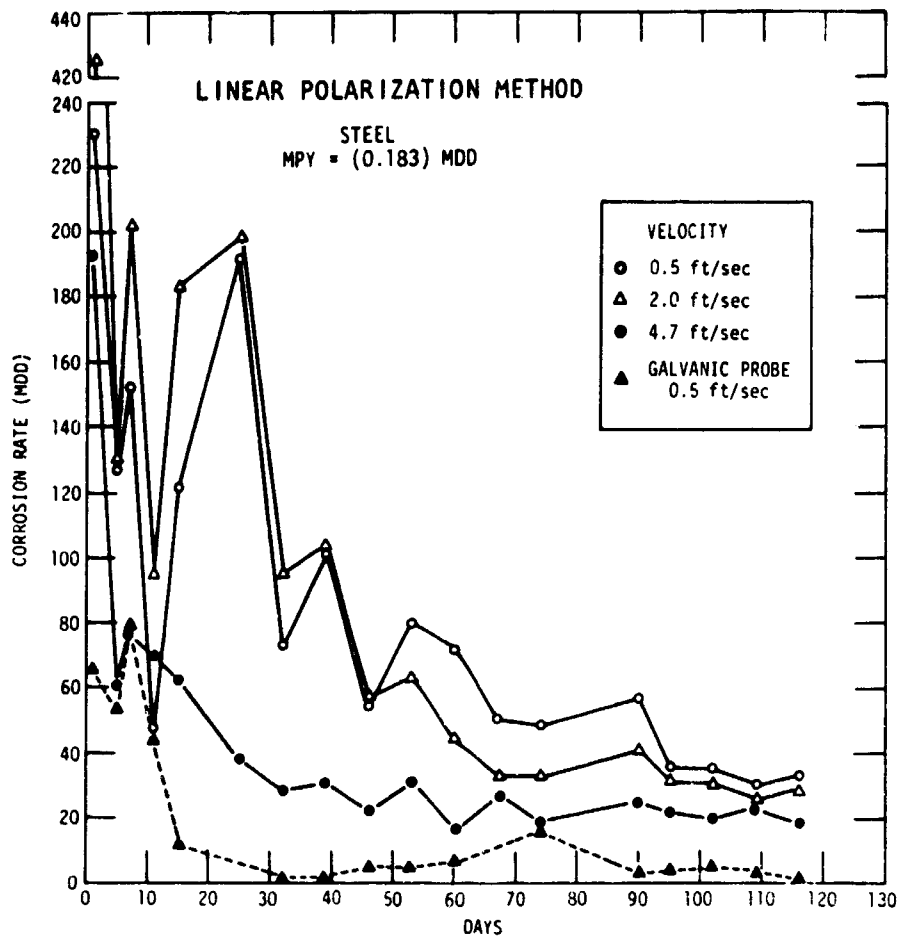

VELOCITY ft/sec	STEEL CORROSION BY WEIGHT LOSS (ASTM, D 2688-C) MDD		
	29 days	91 days	120 days
0.5	76	37	34
2.0	147	63	53
4.7	125	42	40

VELOCITY ft/sec	COPPER CORROSION BY WEIGHT LOSS (ASTM, D 2688-C) MDD		
	29 days	91 days	120 days
0.5	1.5	0.9	0.9
2.0	1.3	1.7	1.8
4.7	2.0	2.2	2.3

AVERAGE ANALYSIS (ppm)															
Iron (Fe)	Copper (Cu)	Zinc (Zn)	Calcium (Ca)	Magnesium (Mg)	Hardness (as CaCO <sub>3</sub> )	Phosphate (as Total PO <sub>4</sub> )	Silica (SiO <sub>2</sub> )	Chloride (Cl)	Sulphate (SO <sub>4</sub> )	Nitrate (NO <sub>3</sub> )	Alkalinity (as CaCO <sub>3</sub> )	Dissolved Solids	Dissolved Oxygen	pH	Temperature (°F)
1.2	.02	.34	64	26	266	7.5	3.0	104	103	4.2	341	620	2.1	7.8	180

Figure 12. Corrosion of Steel and Copper, Site B<sub>2</sub> Run I, Hard Water Plus Added Chloride, Sulfate, 18 ppm Silica, and 6 ppm Polyphosphate

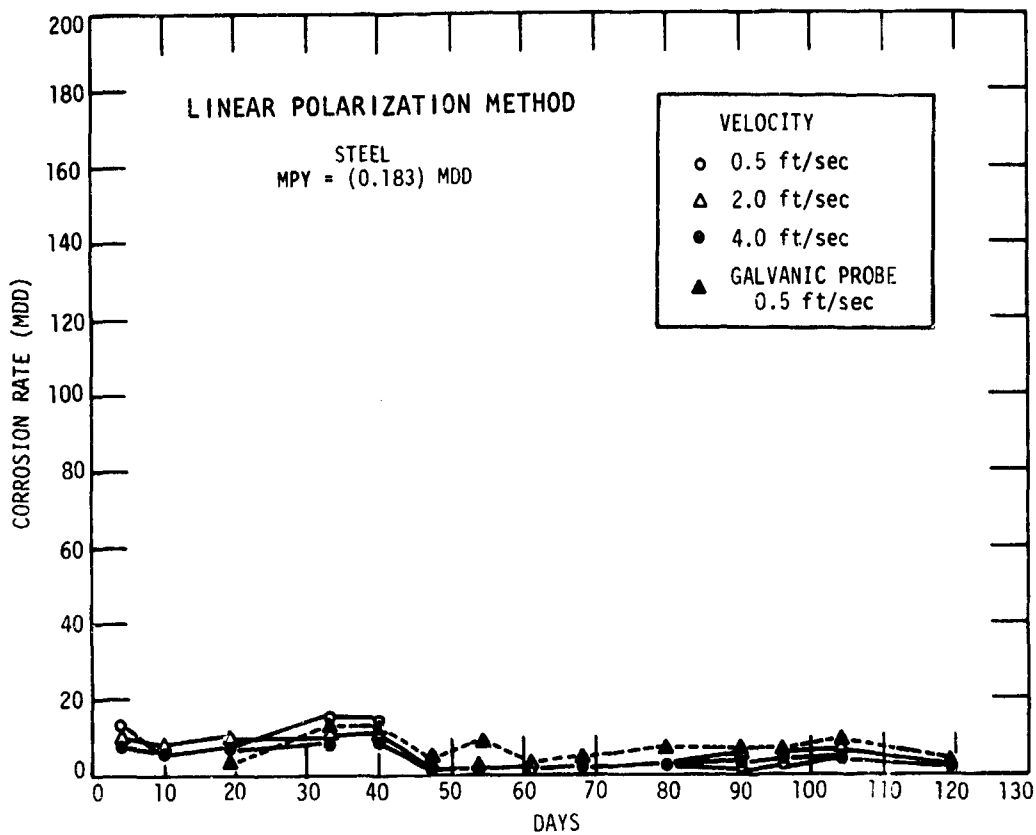

VELOCITY ft/sec	STEEL CORROSION BY WEIGHT LOSS (ASTM, D 2688-C) MDD		
	27 days	92 days	119 days
0.5	28	13	8.3
2.0	62	13	22
4.0	90	29	19

VELOCITY ft/sec	COPPER CORROSION BY WEIGHT LOSS (ASTM, D 2688-C) MDD		
	27 days	92 days	119 days
0.5	6.0	8.3	9.1
2.0	25	34	28
4.0	30	45	42

AVERAGE ANALYSIS (ppm)															
Iron (Fe)	Copper (Cu)	Zinc (Zn)	Calcium (Ca)	Magnesium (Mg)	Hardness (as CaCO <sub>3</sub> )	Phosphate (as Total P <sub>04</sub> )	Silica (SiO <sub>2</sub> )	Chloride (Cl)	Sulphate (SO <sub>4</sub> )	Nitrate (NO <sub>3</sub> )	Alkalinity (as CaCO <sub>3</sub> )	Dissolved Solids	Dissolved Oxygen	pH	Temperature (°F)
0.3	.03	.30	27	25	170	1.4	15	4	1	4.4	342	393	3.6	7.7	178

Figure 13. Corrosion of Steel and Copper, Site B<sub>2</sub> Run II, Hard Water

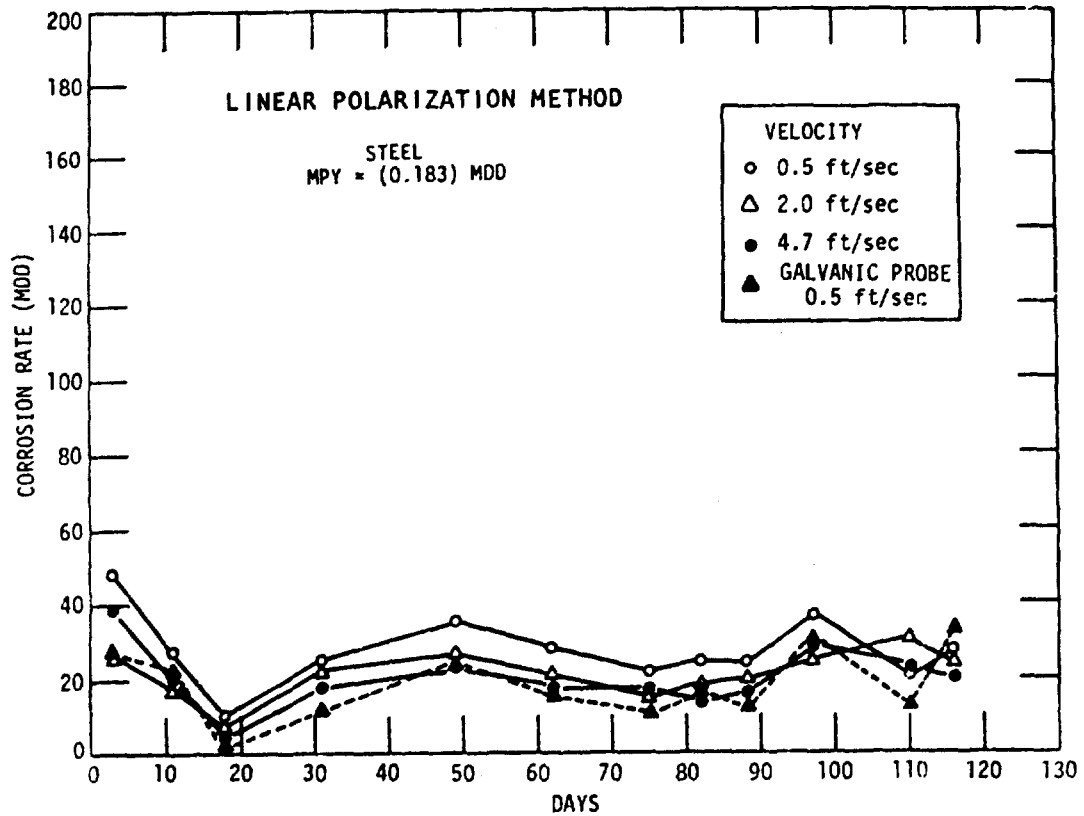

VELOCITY ft/sec	STEEL CORROSION BY WEIGHT LOSS (ASTM, D 2688-C) MDD		
	28 days	94 days	122days
0.5	94	156	77
2.0	209	112	69
4.7	233	80	56

VELOCITY ft/sec	COPPER CORROSION BY WEIGHT LOSS (ASTM, D 2688-C) MDD		
	28 days	94 days	122days
0.5	11	6.2	7.1
2.0	30	40	35
4.7	34	61	56

AVERAGE ANALYSIS (ppm)															
Iron (Fe)	Copper (Cu)	Zinc (Zn)	Calcium (Ca)	Magnesium (Mg)	Hardness (as CaCO <sub>3</sub> )	Phosphate (as Total PO <sub>4</sub> )	Silica (SiO <sub>2</sub> )	Chloride (Cl)	Sulphate (SO <sub>4</sub> )	Nitrate (NO <sub>3</sub> )	Alkalinity (as CaCO <sub>3</sub> )	Dissolved Solids	Dissolved Oxygen	pH	Temperature (°F)
0.4	.04	.16	29	18	145	1.4	15	95	81	3.3	367	655	2.8	8.0	179

Figure 14. Corrosion of Steel and Copper, Site B<sub>2</sub> Run III, Hard Water Plus Added Chloride, Sulfate, and Caustic Soda, pH 8.0



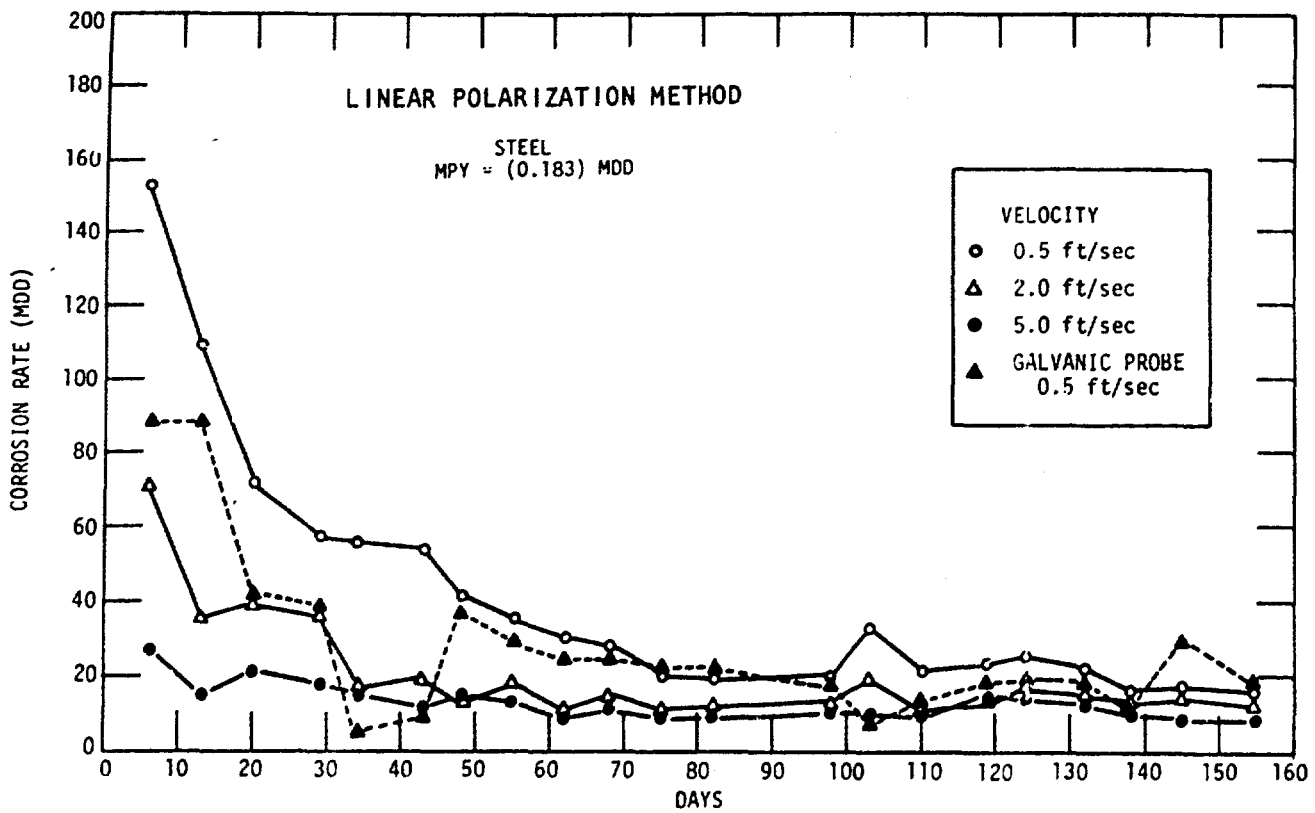

VELOCITY ft/sec	STEEL CORROSION BY WEIGHT LOSS (ASTM, D 2688-C) MDD		
	33 days	86 days	119 days
0.5	95	70	74
2.0	170	57	49
5.0	99	58	31

VELOCITY ft/sec	COPPER CORROSION BY WEIGHT LOSS (ASTM, D 2688-C) MDD		
	33 days	86 days	119 days
0.5	6.1	9.9	8.6
2.0	8.4	14	11
5.0	8.2	21	28

AVERAGE ANALYSIS (ppm)															
Iron (Fe)	Copper (Cu)	Zinc (Zn)	Calcium (Ca)	Magnesium (Mg)	Hardness (as CaCO <sub>3</sub> )	Phosphate (as Total PO <sub>4</sub> )	Silica (SiO <sub>2</sub> )	Chloride (Cl)	Sulphate (SO <sub>4</sub> )	Nitrate (NO <sub>3</sub> )	Alkalinity (as CaCO <sub>3</sub> )	Dissolved Solids	Dissolved Oxygen	pH	Temperature (°F)
0.31	.18	.25	3.5	1.3	16	0.0	7	19	51	8.1	247	403	2.0	7.6	133

Figure 15. Corrosion of Steel and Copper, Site C<sub>1</sub> Run I, Soft Water

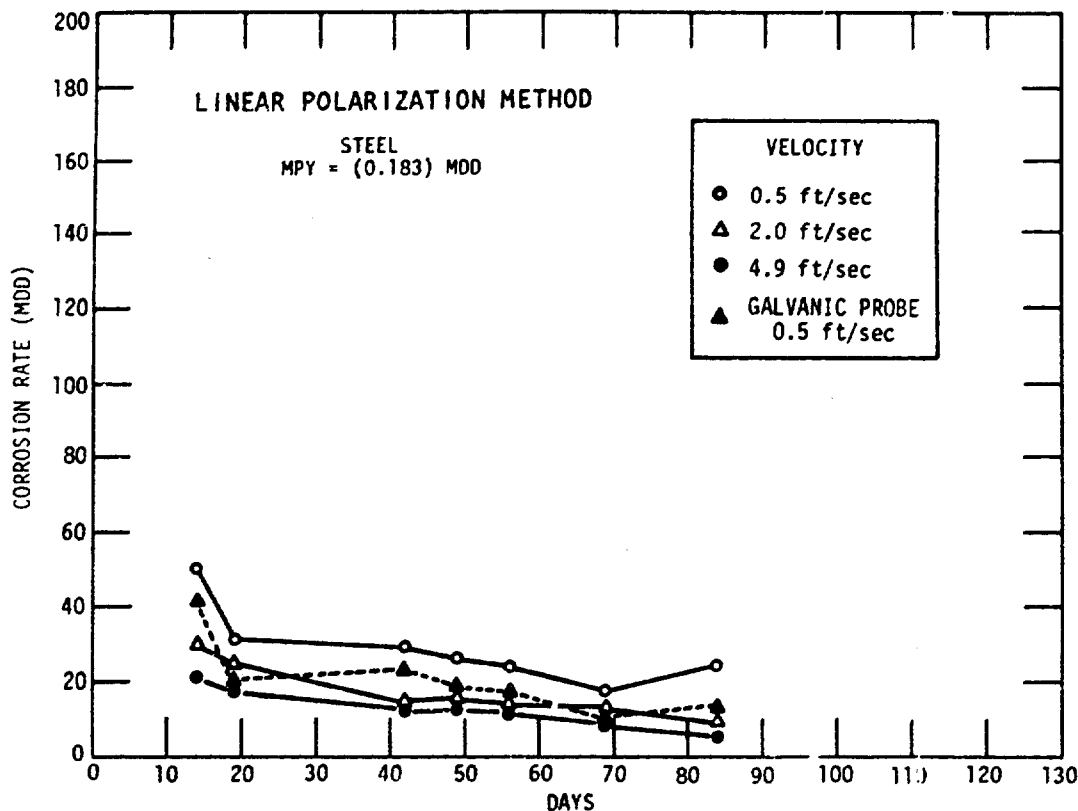

VELOCITY ft/sec	STEEL CORROSION BY WEIGHT LOSS (ASTM, D 2688-C) MDD		
	28 days	62 days	90 days
0.5	90	50	53
2.0	146	89	51
4.9	95	47	35

VELOCITY ft/sec	COPPER CORROSION BY WEIGHT LOSS (ASTM, D 2688-C) MDD		
	28 days	62 days	90 days
0.5	9.3	6.6	8.1
2.0	11	12	13
4.9	16	15	17

AVERAGE ANALYSIS (ppm)															
Iron (Fe)	Copper (Cu)	Zinc (Zn)	Calcium (Ca)	Magnesium (Mg)	Hardness (as CaCO <sub>3</sub> )	Phosphate (as Total PO <sub>4</sub> )	Silica (SiO <sub>2</sub> )	Chloride (Cl)	Sulphate (SO <sub>4</sub> )	Nitrate (NO <sub>3</sub> )	Alkalinity (as CaCO <sub>3</sub> )	Dissolved Solids	Dissolved Oxygen	pH	Temperature (°F)
0.0	.14	.04	12	7	62	0.0	13	21	44	3.9	275	413	1.4	8.0	143

Figure 16. Corrosion of Steel and Copper, Site C<sub>1</sub> Run II, Blended Hardness, Added 10 ppm Silica, pH 8.0

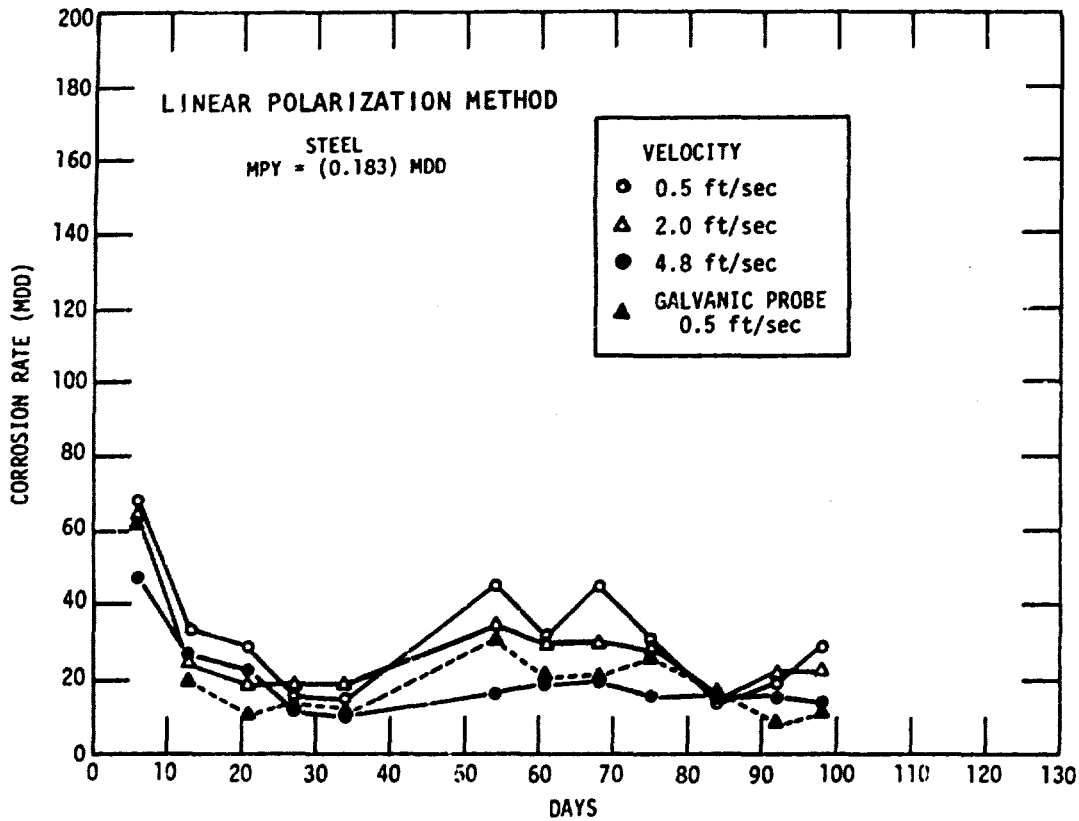

VELOCITY ft/sec	STEEL CORROSION BY WEIGHT LOSS (ASTM, D 2688-C) MDD		
	27 days	71 days	98 days
0.5	46	41	33
2.0	72	60	37
4.8	115	38	45

VELOCITY ft/sec	COPPER CORROSION BY WEIGHT LOSS (ASTM, D 2688-C) MDD		
	27 days	71 days	98 days
0.5	5.1	6.9	6.7
2.0	9.5	13	11
4.8	11	17	13

AVERAGE ANALYSIS (ppm)															
Iron (Fe)	Copper (Cu)	Zinc (Zn)	Calcium (Ca)	Magnesium (Mg)	Hardness (as CaCO <sub>3</sub> )	Phosphate (as Total PO <sub>4</sub> )	Silica (SiO <sub>2</sub> )	Chloride (Cl)	Sulphate (SO <sub>4</sub> )	Nitrate (NO <sub>3</sub> )	Alkalinity (as CaCO <sub>3</sub> )	Dissolved Solids	Dissolved Oxygen	pH	Temperature (°F)
0.1	.15	.04	2.5	1.2	10	0.0	11	21	42	1.0	286	444	0.6	8.1	144

Figure 17. Corrosion of Steel and Copper, Site C<sub>1</sub> Run III, Soft Water, Added 6 ppm Silica, and 3.5 ppm Tannin, pH 8.1

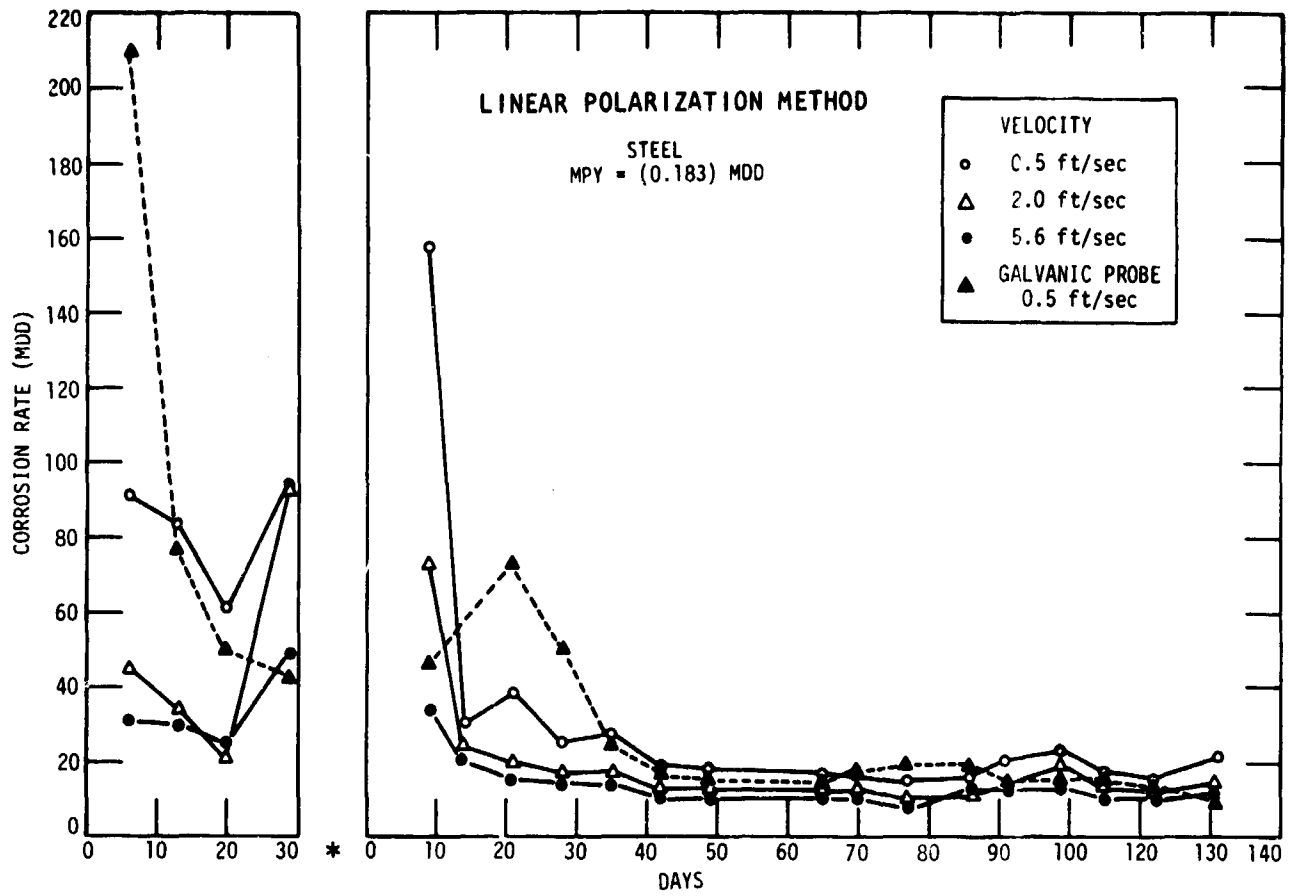

VELOCITY ft/sec	STEEL CORROSION BY WEIGHT LOSS (ASTM, D 2688-C) MDD		
	28 days	91 days	119 days
0.5	109	58	51
2.0	106	61	40
5.6	114	50	36

VELOCITY ft/sec	COPPER CORROSION BY WEIGHT LOSS (ASTM, D 2588-C) MDD		
	28 days	91 days	119 days
0.5	4.9	8.0	7.1
2.0	6.3	9.9	8.6
5.6	8.7	11	11

AVERAGE ANALYSIS (ppm)															
Iron (Fe)	Copper (Cu)	Zinc (Zn)	Calcium (Ca)	Magnesium (Mg)	Hardness (as CaCO <sub>3</sub> )	Phosphate (as Total PO <sub>4</sub> )	Silica (SiO <sub>2</sub> )	Chloride (Cl)	Sulphate (SO <sub>4</sub> )	Nitrate (NO <sub>3</sub> )	Alkalinity (as CaCO <sub>3</sub> )	Dissolved Solids	Dissolved Oxygen	pH	Temperature (°F)
0.1	.26	.28	4.0	1.2	19	0.0	7	18	52	7.4	248	388	2.2	7.7	126

Figure 18. Corrosion of Steel and Copper,  
Site C<sub>2</sub> Run I, Soft Water  
\* Run Restarted After Velocities Corrected

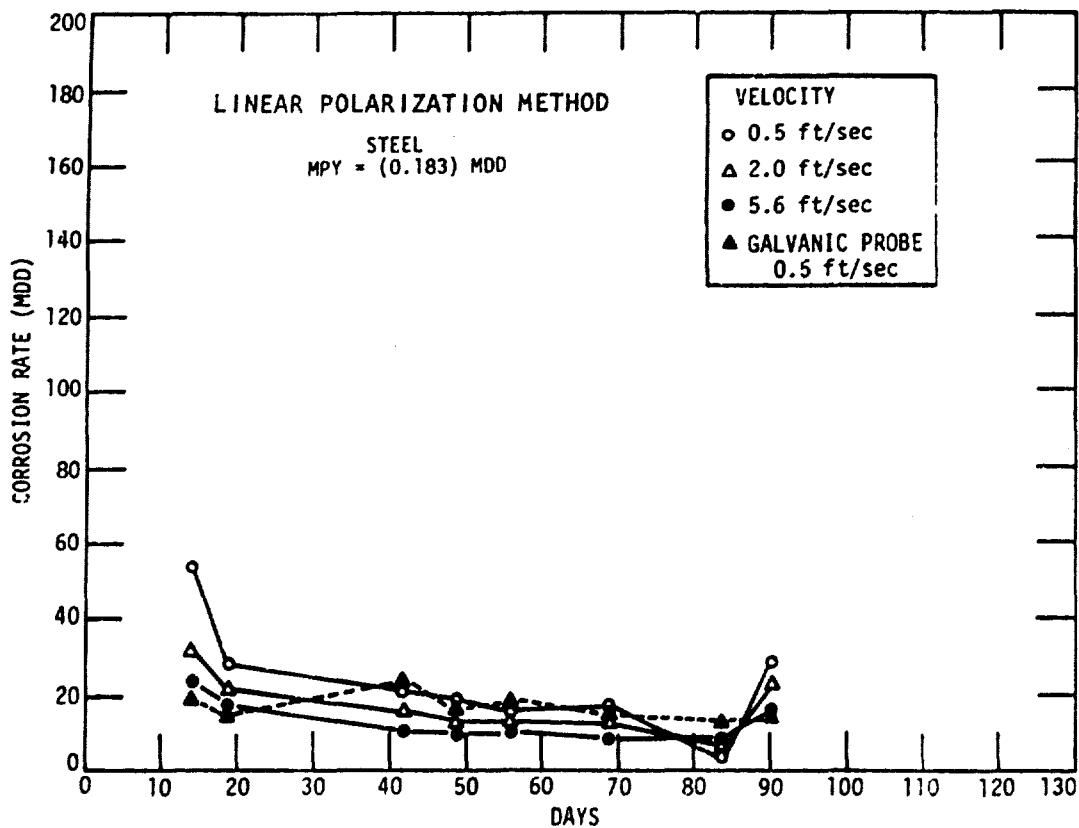

VELOCITY ft/sec	STEEL CORROSION BY WEIGHT LOSS (ASTM, D 2688-C) MDD		
	28 days	62 days	90 days
0.5	61	40	61
2.0	88	73	53
5.6	143	46	33

VELOCITY ft/sec	COPPER CORROSION BY WEIGHT LOSS (ASTM, D 2688-C) MDD		
	28 days	62 days	90 days
0.5	7.0	6.4	7.3
2.0	6.0	11	8.1
5.6	9.9	17	13

AVERAGE ANALYSIS (ppm)															
Iron (Fe)	Copper (Cu)	Zinc (Zn)	Calcium (Ca)	Magnesium (Mg)	Hardness (as CaCO <sub>3</sub> )	Phosphate (as Total PO <sub>4</sub> )	Silica (SiO <sub>2</sub> )	Chloride (Cl)	Sulphate (SO <sub>4</sub> )	Nitrate (NO <sub>3</sub> )	Alkalinity (as CaCO <sub>3</sub> )	Dissolved Solids	Dissolved Oxygen	pH	Temperature (°F)
0.0	.20	.06	15	7	56	0.0	13	20	44	4.9	274	403	1.2	7.8	132

Figure 19. Corrosion of Steel and Copper, Site C<sub>2</sub> Run II, Blended Hardness, Added 10 ppm Silica, pH 7.8

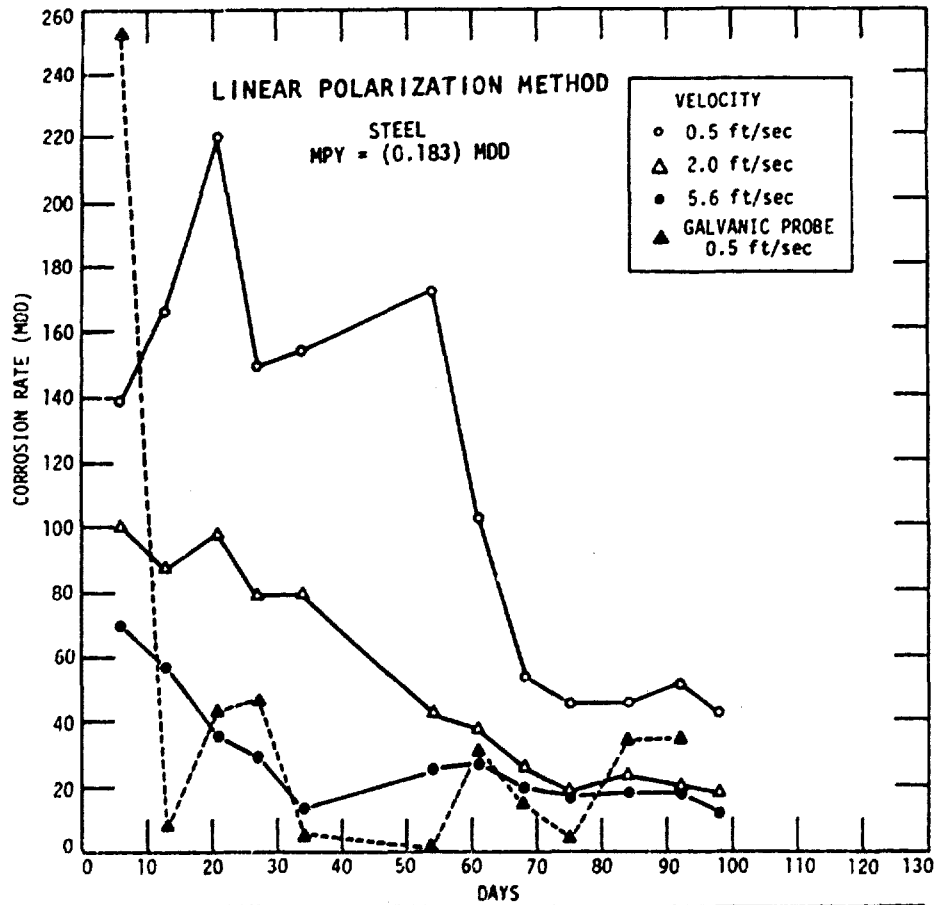

VELOCITY ft/sec	STEEL CORROSION BY WEIGHT LOSS (ASTM, D 2688-C) MDD		
	27 days	71 days	98 days
0.5	41	44	30
2.0	64	62	34
5.6	133	31	41

VELOCITY ft/sec	COPPER CORROSION BY WEIGHT LOSS (ASTM, D 2688-C) MDD		
	27 days	71 days	98 days
0.5	1.4	3.6	3.7
2.0	1.3	6.9	4.2
5.6	1.8	12	6.8

AVERAGE ANALYSIS (ppm)															
Iron (Fe)	Copper (Cu)	Zinc (Zn)	Calcium (Ca)	Magnesium (Mg)	Hardness (as CaCO <sub>3</sub> )	Phosphate (as PO <sub>4</sub> Total)	Silica (SiO <sub>2</sub> )	Chloride (Cl)	Sulphate (SO <sub>4</sub> )	Nitrate (NO <sub>3</sub> )	Alkalinity (as CaCO <sub>3</sub> )	Dissolved Solids	Dissolved Oxygen	pH	Temperature (°F)
0.1	.17	.04	2.6	1.0	10	0.0	11	20	42	1.0	284	437	0.5	8.1	135

Figure 20. Corrosion of Steel and Copper, Site C<sub>2</sub> Run III, Soft Water, Added 6 ppm Silica, and 3.5 ppm Tannin, pH 8.1

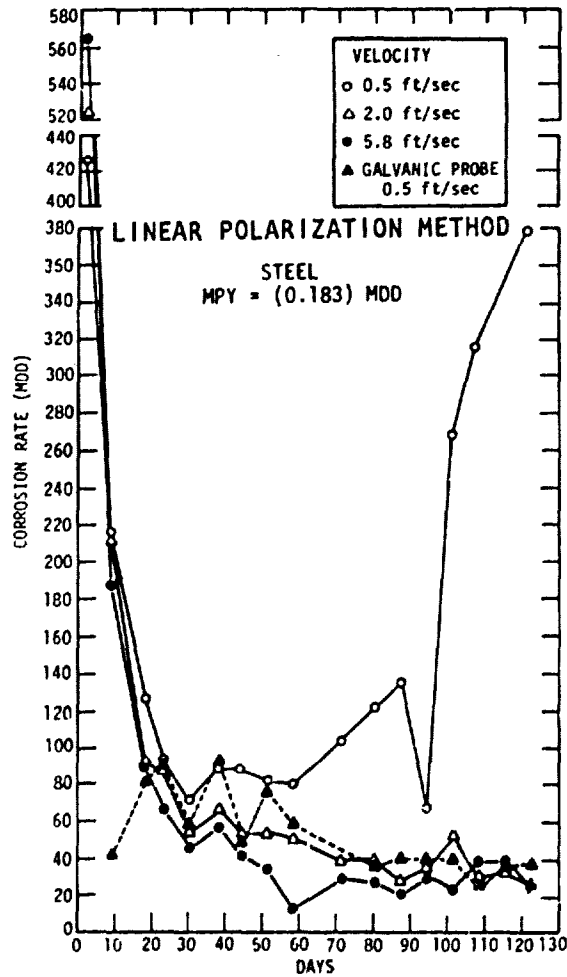

VELOCITY ft/sec	STEEL CORROSION BY WEIGHT LOSS (ASTM, D 2688-C) MDD			VELOCITY ft/sec	COPPER CORROSION BY WEIGHT LOSS (ASTM, D 2688-C) MDG		
	30 days	92 days	122 days		30 days	92 days	122 days
0.5	155	120	102	0.5	31	26	14
2.0	393	162	151	2.0	42	18	15
5.8	358	103	119	5.8	45	22	16

AVERAGE ANALYSIS (ppm)															
Iron (Fe)	Copper (Cu)	Zinc (Zn)	Calcium (Ca)	Magnesium (Mg)	Hardness (as CaCO <sub>3</sub> )	Phosphate (as P <sub>2</sub> O <sub>4</sub> Total)	Silica (SiO <sub>2</sub> )	Chloride (Cl)	Sulphate (SO <sub>4</sub> )	Nitrate (NO <sub>3</sub> )	Alkalinity (as CaCO <sub>3</sub> )	Dissolved Solids	Dissolved Oxygen	pH	Temperature (°F)
1.2	.02	.50	15	8	71	0.0	8	431	207	1.1	264	1337	6.3	7.8	132

Figure 21. Corrosion of Steel and Copper, Site D<sub>1</sub> Run I, Blended Hardness

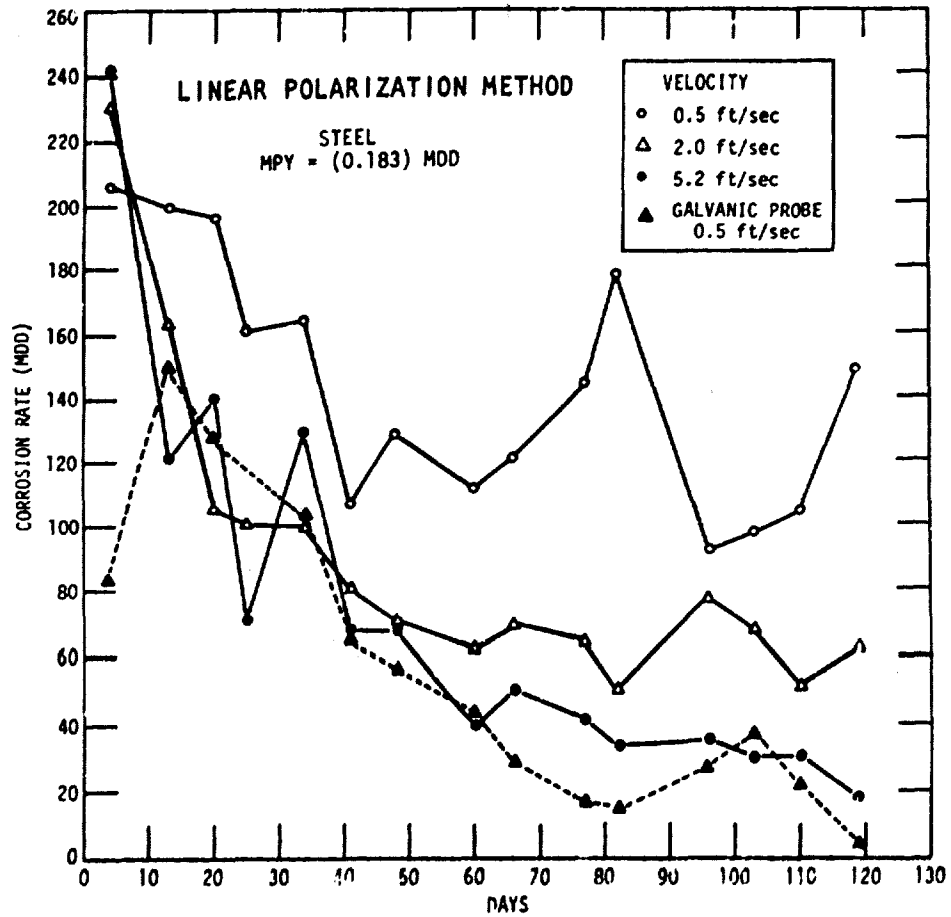

VELOCITY ft/sec	STEEL CORROSION BY WEIGHT LOSS (ASTM, D 2688-C) MDD		
	28 days	91 days	119 days
0.5	292	128	115
2.0	363	150	105
5.2	315	106	85

VELOCITY ft/sec	COPPER CORROSION BY WEIGHT LOSS (ASTM, D 2688-C) MDD		
	28 days	91 days	119 days
0.5	3.0	4.5	3.4
2.0	11	6.3	3.7
5.2	12	6.6	4.0

AVERAGE ANALYSIS (ppm)															
Iron (Fe)	Copper (Cu)	Zinc (Zn)	Calcium (Ca)	Magnesium (Mg)	Hardness (as CaCO <sub>3</sub> )	Phosphate (as Total PO <sub>4</sub> )	Silica (SiO <sub>2</sub> )	Chloride (Cl)	Sulphate (SO <sub>4</sub> )	Nitrate (NO <sub>3</sub> )	Alkalinity (as CaCO <sub>3</sub> )	Dissolved Solids	Dissolved Oxygen	pH	Temperature (°F)
0.3	.01	.10	14	8	66	0.0	28	390	201	0.0	281	1338	6.1	8.1	118

Figure 22. Corrosion of Steel and Copper, Site D<sub>1</sub> Run II, Blended Hardness, Added 22 ppm Silica, pH 8.1



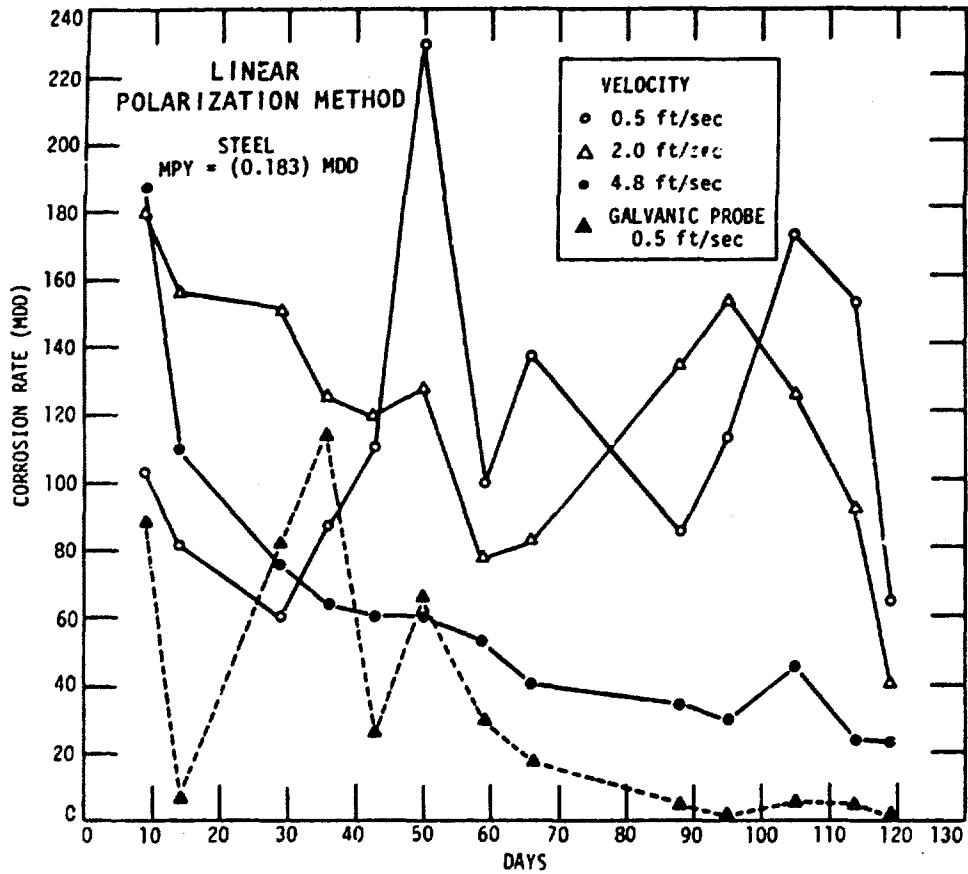

VELOCITY ft/sec	STEEL CORROSION BY WEIGHT LOSS (ASTM, D 2688-C) MDD		
	29 days	90 days	119 days
0.5	141	99	84
2.0	294	131	107
4.8	277	93	95

VELOCITY ft/sec	COPPER CORROSION BY WEIGHT LOSS (ASTM, D 2688-C) MDD		
	29 days	90 days	119 days
0.5	7.1	5.7	3.2
2.0	9.8	5.5	3.5
4.8	9.7	5.8	3.6

AVERAGE ANALYSIS (ppm)															
Iron (Fe)	Copper (Cu)	Zinc (Zn)	Calcium (Ca)	Magnesium (Mg)	Hardness (as CaCO <sub>3</sub> )	Phosphate (as Total PO <sub>4</sub> )	Silica (SiO <sub>2</sub> )	Chloride (Cl)	Sulphate (SO <sub>4</sub> )	Nitrate (NO <sub>3</sub> )	Alkalinity (as CaCO <sub>3</sub> )	Dissolved Solids	Dissolved Oxygen	pH	Temperature (°F)
0.1	.01	.03	16	9	77	0.0	14	363	223	0.0	277	1294	6.8	8.1	132

Figure 23. Corrosion of Steel and Copper, Site D<sub>1</sub> Run III, Blended Hardness, Added 11 ppm Silica, pH 8.1

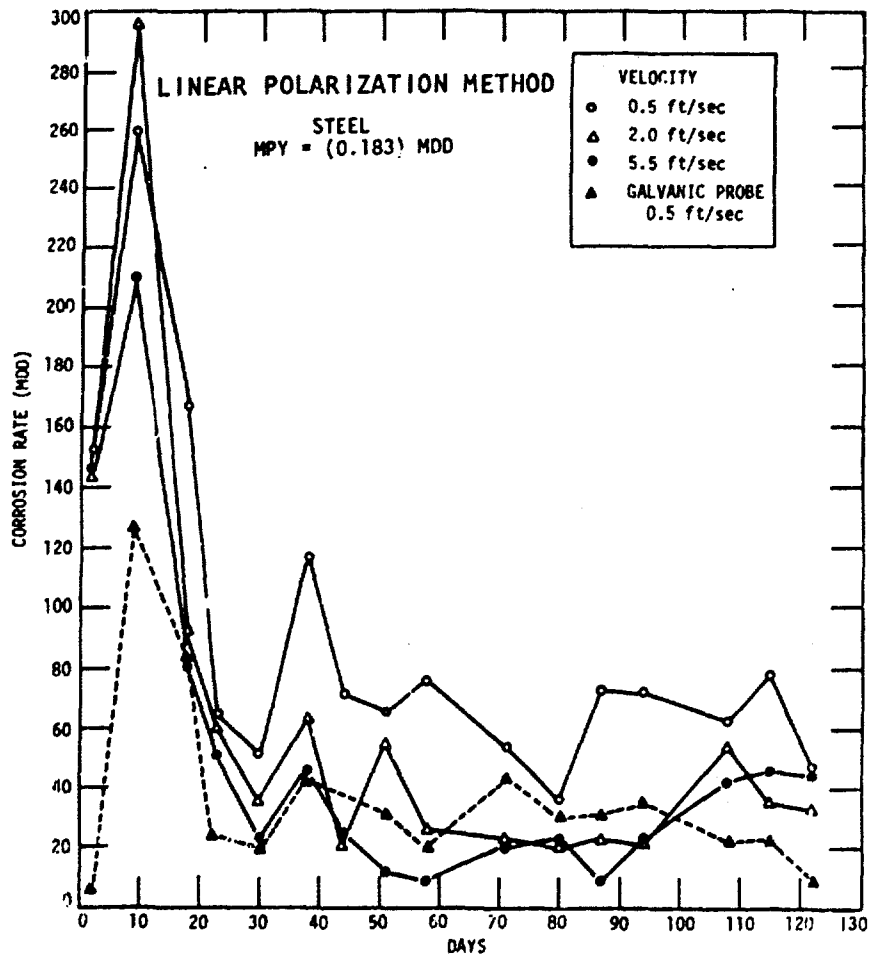

VELOCITY ft/sec	STEEL CORROSION BY WEIGHT LOSS (ASTM, D 2688-C) MDD		
	30 days	92 days	122 days
0.5	123	78	67
2.0	155	104	81
5.5	171	106	61

VELOCITY ft/sec	COPPER CORROSION BY WEIGHT LOSS (ASTM, D 2688-C) MDD		
	30 days	92 days	122 days
0.5	26	14	10
2.0	35	19	15
5.5	36	25	17

AVERAGE ANALYSIS (ppm)															
Iron (Fe)	Copper (Cu)	Zinc (Zn)	Calcium (Ca)	Magnesium (Mg)	Hardness (as CaCO <sub>3</sub> )	Phosphate (as PO <sub>4</sub> )	Silica (SiO <sub>2</sub> )	Chloride (Cl)	Sulphate (SO <sub>4</sub> )	Nitrate (NO <sub>3</sub> )	Alkalinity (as CaCO <sub>3</sub> )	Dissolved Solids	Dissolved Oxygen	pH	Temperature (°F)
1.0	.02	.80	12	7.6	63	0.0	7	434	203	1.1	256	1336	1.8	7.8	181

Figure 24. Corrosion of Steel and Copper, Site D2 Run I, Blended Hardness

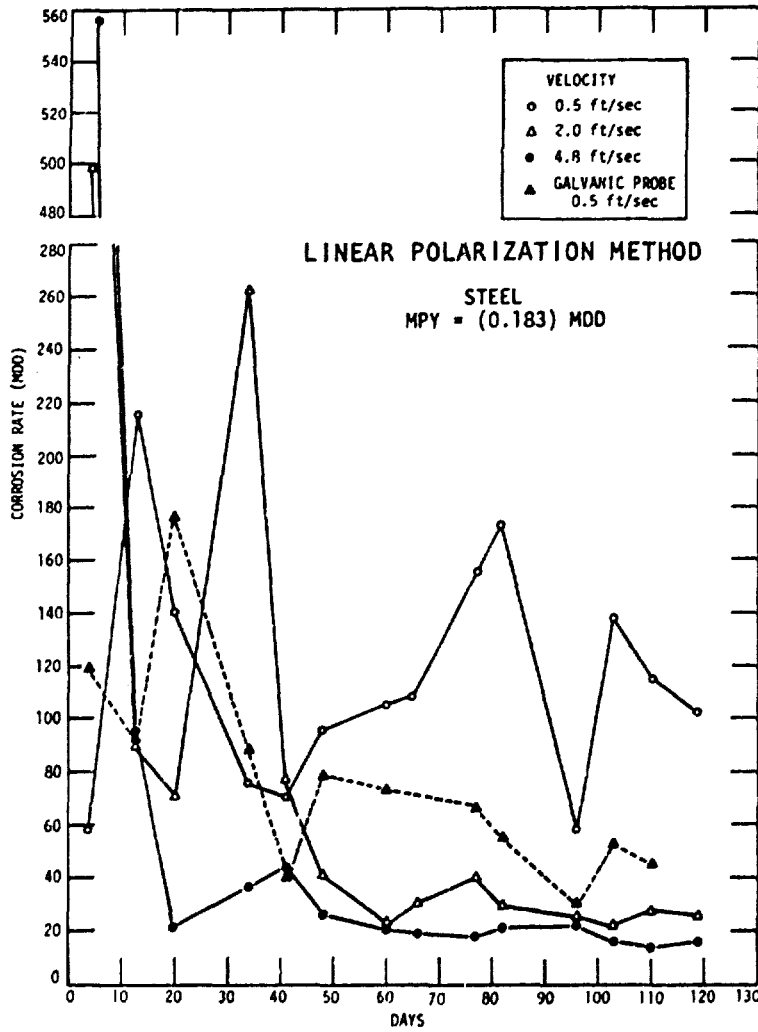

VELOCITY ft/sec	STEEL CORROSION BY WEIGHT LOSS (ASTM, D 2688-C) MDD			VELOCITY ft/sec	COPPER CORROSION BY WEIGHT LOSS (ASTM, D 2688-C) MDD		
	28 days	91 days	119 days		28 days	91 days	119 days
0.5	140	82	67	0.5	16	6.1	5.1
2.0	173	113	77	2.0	27	16	9.1
4.8	170	114	71	4.8	34	16	13

AVERAGE ANALYSIS (ppm)											
Iron (Fe)	Copper (Cu)	Zinc (Zn)	Calcium (Ca)	Magnesium (Mg)	Hardness (as CaCO <sub>3</sub> )	Phosphate (as Total P <sub>2</sub> O <sub>5</sub> )	Silica (SiO <sub>2</sub> )	Chloride (Cl)	Sulphate (SO <sub>4</sub> )	Nitrate (NO <sub>3</sub> )	Alkalinity (as CaCO <sub>3</sub> )
0.2	1.01	60	13	9	70	0.023	1395	202	0.0	279	1326
											3.5
											Dissolved Solids
											Dissolved Oxygen
											pH
											Temperature (°F)
											8.1
											181

Figure 25. Corrosion of Steel and Copper, Site D<sub>2</sub> Run II, Blended Hardness, Added 22 ppm Silica, pH 8.1

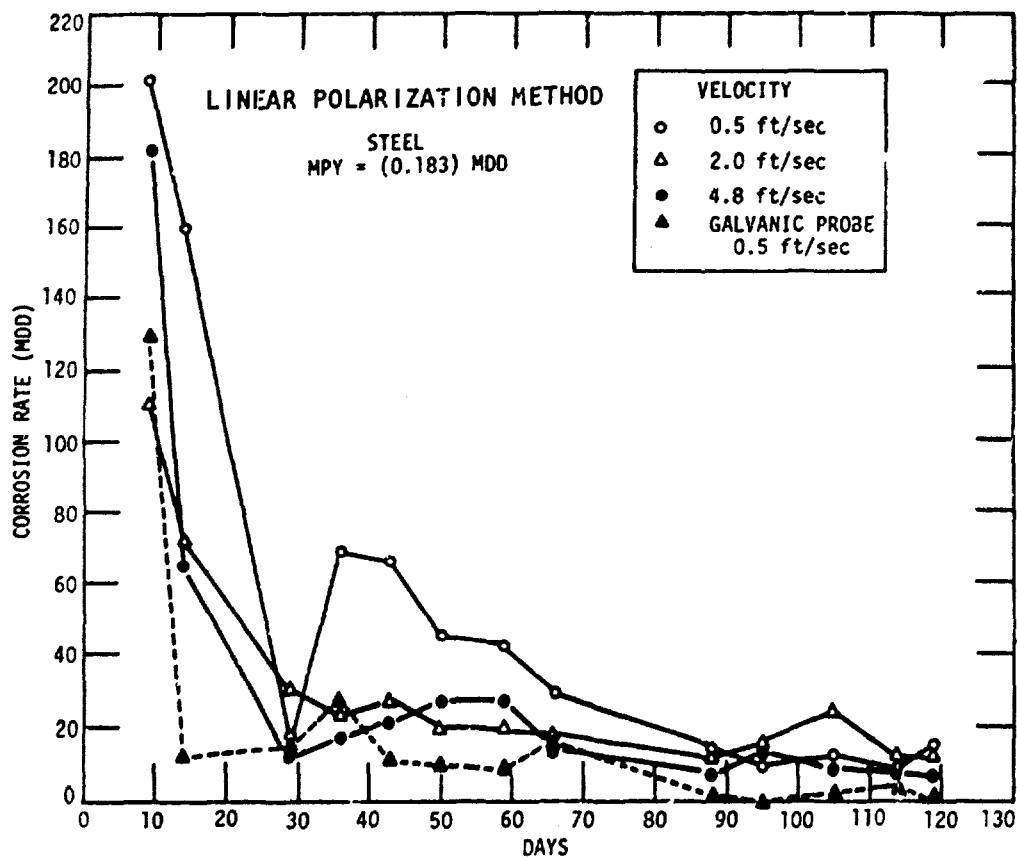

VELOCITY ft/sec	STEEL CORROSION BY WEIGHT LOSS (ASTM, D 2688-C) MDD		
	29 days	90 days	119 days
0.5	160	108	83
2.0	201	136	85
4.8	229	145	98

VELOCITY ft/sec	COPPER CORROSION BY WEIGHT LOSS (ASTM, D 2688-C) MDD		
	29 days	90 days	119 days
0.5	17	6.1	5.6
2.0	31	13	10
4.8	31	15	13

AVERAGE ANALYSIS (ppm)															
Iron (Fe)	Copper (Cu)	Zinc (Zn)	Calcium (Ca)	Magnesium (Mg)	Hardness (as CaCO <sub>3</sub> )	Phosphate (as Total PO <sub>4</sub> )	Silica (SiO <sub>2</sub> )	Chloride (Cl)	Sulphate (SO <sub>4</sub> )	Nitrate (NO <sub>3</sub> )	Alkalinity (as CaCO <sub>3</sub> )	Dissolved Solids	Dissolved Oxygen	pH	Temperature (°F)
0.1	.01	.04	10	8.7	66	0.0	15	403	209	0.0	277	1284	4.4	8.0	181

Figure 26. Corrosion of Steel and Copper, Site D<sub>2</sub> Run III, Blended Hardness, Added 11 ppm Silica, pH 8.0

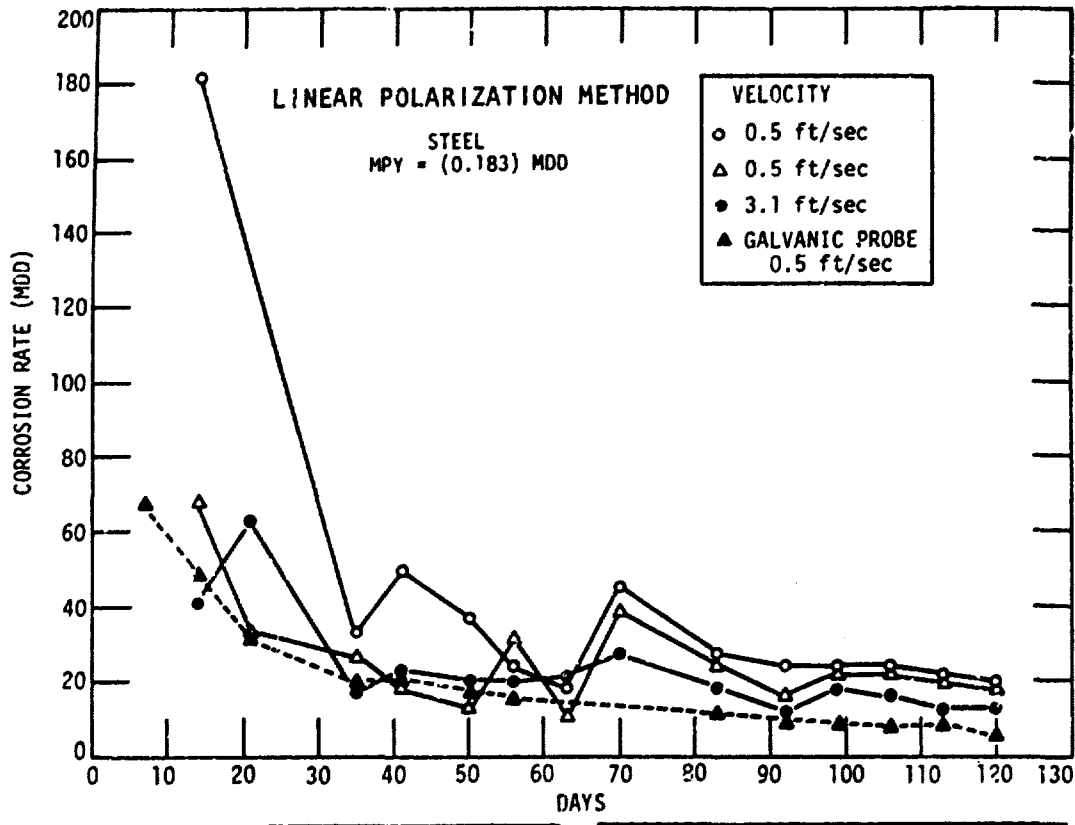

VELOCITY ft/sec	STEEL CORROSION BY WEIGHT LOSS (ASTM, D 2688-C) MDD		
	30 days	90days	120 days
0.5	243	120	87
0.5	226	105	89
3.1	166	86	63

VELOCITY ft/sec	COPPER CORROSION BY WEIGHT LOSS (ASTM, D 2688-C) MDD		
	30 days	90 days	120days
0.5	3.0	6.0	3.4
0.5	3.0	6.1	4.6
3.1	4.0	8.3	5.1

AVERAGE ANALYSIS (ppm)															
Iron (Fe)	Copper (Cu)	Zinc (Zn)	Calcium (Ca)	Magnesium (Mg)	Hardness (as CaCO <sub>3</sub> )	Phosphate (as Total PO <sub>4</sub> )	Silica (SiO <sub>2</sub> )	Chloride (Cl)	Sulphate (SO <sub>4</sub> )	Nitrate (NO <sub>3</sub> )	Alkalinity (as CaCO <sub>3</sub> )	Dissolved Solids	Dissolved Oxygen	pH	Temperature (°F)
0.5	.40	.30	11	6	54	0.1	3	30	127	30	236	518	5.7	7.7	144

Figure 27. Corrosion of Steel and Copper, Cite E Run I, Blended Hardness

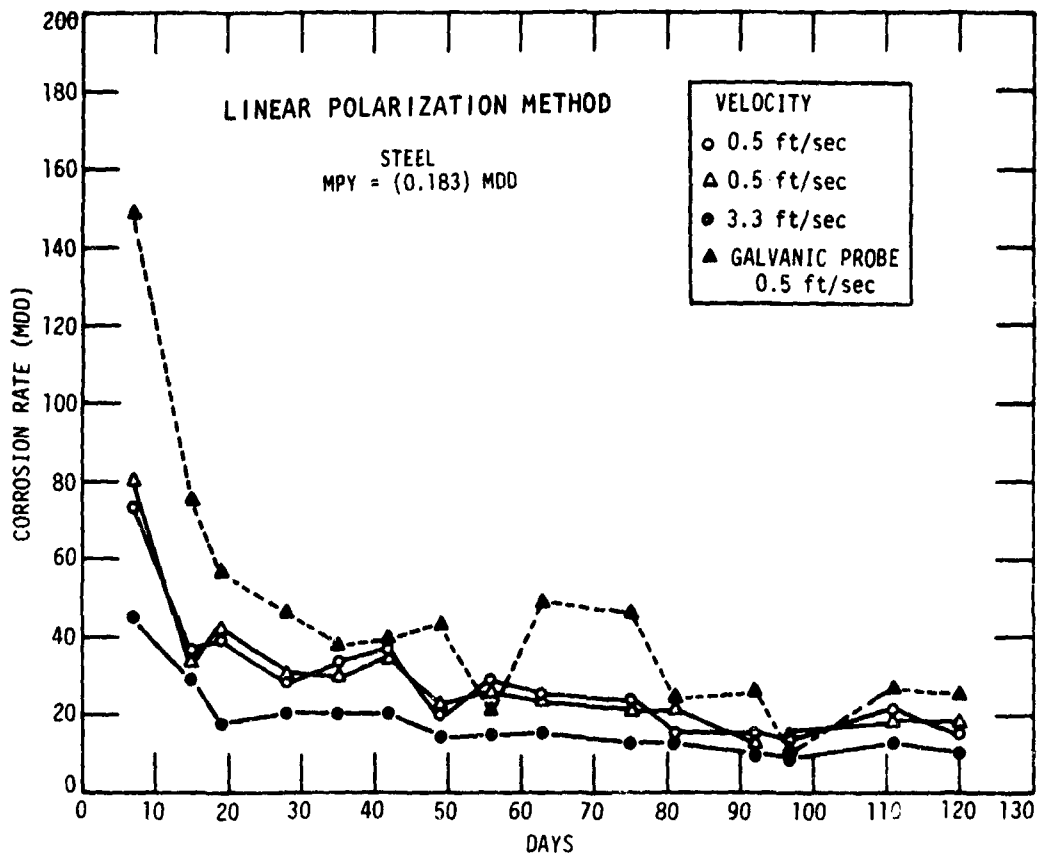

VELOCITY ft/sec	STEEL CORROSION BY WEIGHT LOSS (ASTM, D 2688-C) MDD		
	32 days	88 days	120days
	0.5	267	114
0.5	256	106	105
3.3	186	76	71

VELOCITY ft/sec	COPPER CORROSION BY WEIGHT LOSS (ASTM, D 2688-C) MDD		
	32 days	88 days	120days
	0.5	4.4	3.7
0.5	3.6	5.4	4.1
3.3	6.3	13	8.1

AVERAGE ANALYSIS (ppm)															
Iron (Fe)	Copper (Cu)	Zinc (Zn)	Calcium (Ca)	Magnesium (Mg)	Hardness (as CaCO <sub>3</sub> )	Phosphate (as Total PO <sub>4</sub> )	Silica (SiO <sub>2</sub> )	Chloride (Cl)	Sulphate (SO <sub>4</sub> )	Nitrate (NO <sub>3</sub> )	Alkalinity (as CaCO <sub>3</sub> )	Dissolved Solids	Dissolved Oxygen	pH	Temperature (°F)
0.5	.27	.15	12	8	55	0.1	10	25	106	51	195	492	6.8	8.1	46

Figure 28. Corrosion of Steel and Copper, Site E Run II, Blended Hardness, Added 10 ppm Silica, pH 3.1

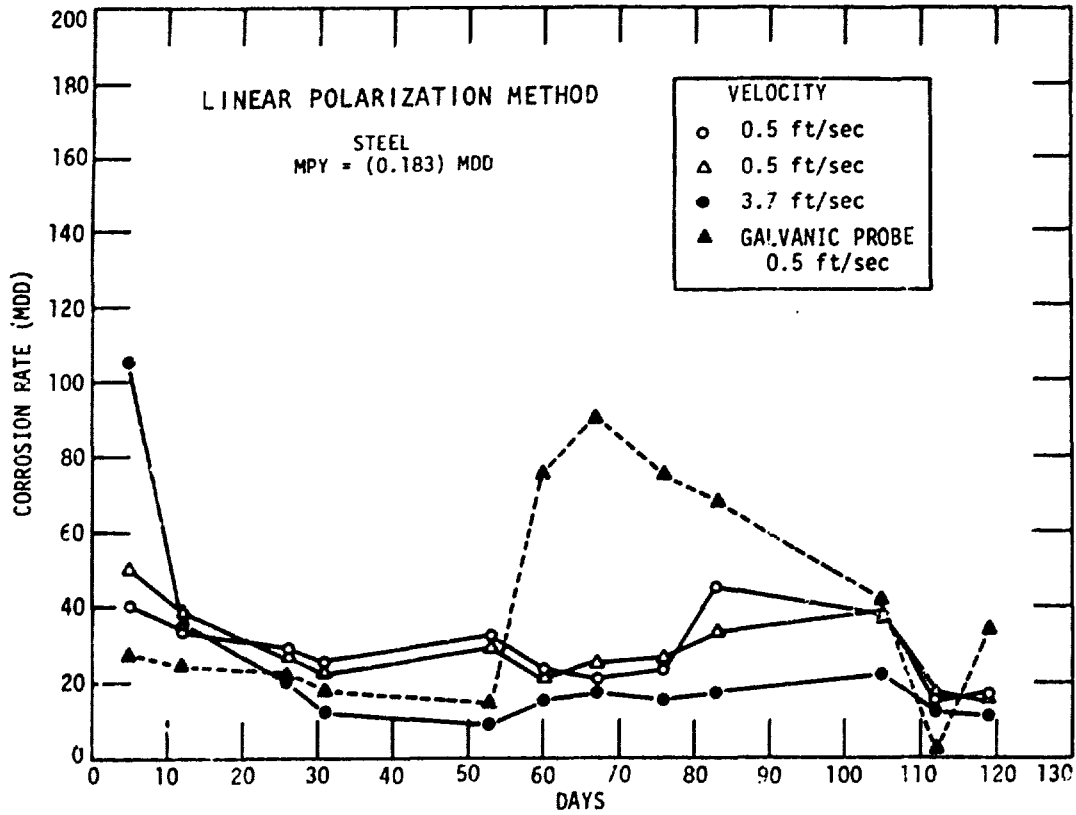

VELOCITY ft/sec	STEEL CORROSION BY WEIGHT LOSS (ASTM, D 2688-C) MDD		
	31 days	88 days	119 days
0.5	224	120	77
0.5	222	106	85
3.7	184	75	66

VELOCITY ft/sec	COPPER CORROSION BY WEIGHT LOSS (ASTM, D 2688-C) MDD		
	31 days	88 days	119 days
0.5	6.8	12	9.6
0.5	8.2	15	12
3.7	5.0	36	12

AVERAGE ANALYSIS (ppm)															
Iron (Fe)	Copper (Cu)	Zinc (Zn)	Calcium (Ca)	Magnesium (Mg)	Hardness (as CaCO <sub>3</sub> )	Phosphate (as Total PO <sub>4</sub> )	Silica (SiO <sub>2</sub> )	Chloride (Cl)	Sulphate (SO <sub>4</sub> )	Nitrate (NO <sub>3</sub> )	Alkalinity (as CaCO <sub>3</sub> )	Dissolved Solids	Dissolved Oxygen	pH	Temperature (°F)
0.1	.13	.04	15	9	73	0.0	9	26	87	35	235	500	6.2	8.2	153

Figure 29. Corrosion of Steel and Copper, Site E Run III, Blended Hardness, Added 5 ppm Silica, pH 8.2

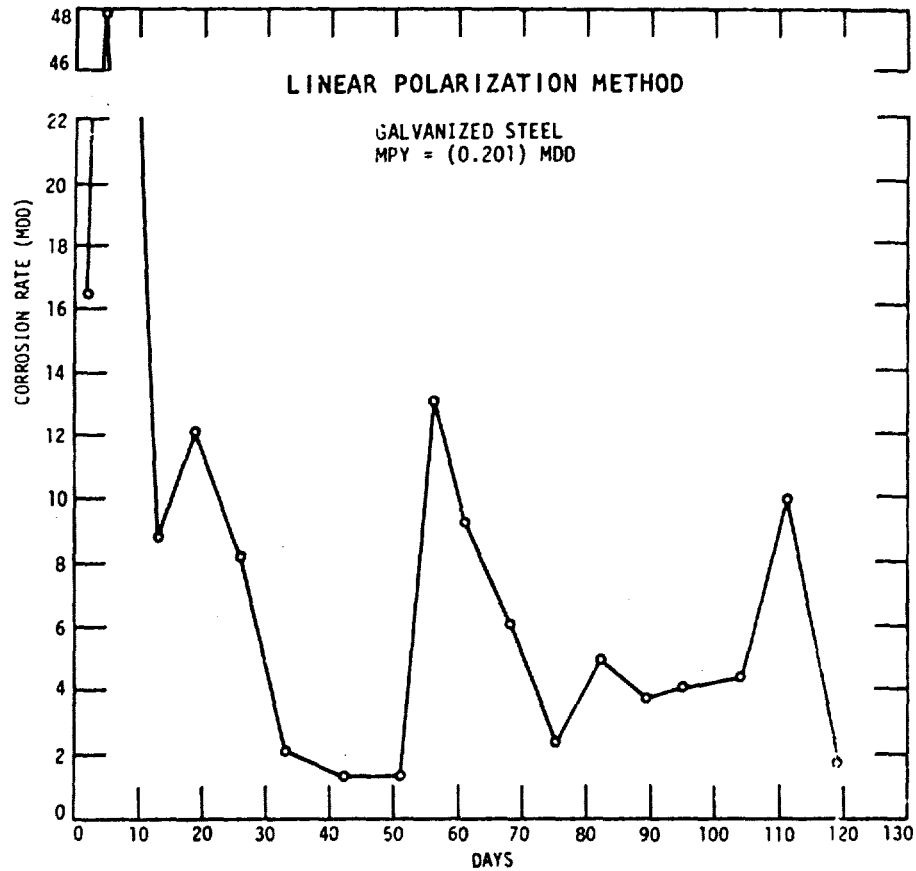

VELOCITY AND DIAMETER	GALVANIZED CORROSION BY WEIGHT LOSS (ASTM, D 2688-C) MDD		
	29 days	90 days	119 days
1" dia 1.3 ft/sec	46	27	20
1/2" dia 4.8 ft/sec	39	16	11

TIME days	CREVICE CORROSION BY WEIGHT LOSS (ASTM, D 2688-C) MDD VELOCITY: 1.3 ft/sec		
	1" Zn	1" Zn	2" Zn
29	38	46	49
90	25	21	30
119	23	17	18

AVERAGE ANALYSIS (ppm)															
Iron (Fe)	Copper (Cu)	Zinc (Zn)	Calcium (Ca)	Magnesium (Mg)	Hardness (as CaCO <sub>3</sub> )	Phosphate (as total P <sub>04</sub> )	Silica (SiO <sub>2</sub> )	Chloride (Cl)	Sulphate (SO <sub>4</sub> )	Nitrate (NO <sub>3</sub> )	Alkalinity (as CaCO <sub>3</sub> )	Dissolved Solids	Dissolved Oxygen	pH	Temperature (°F)
0.5	0.02	1.60	1.0	0.8	4	0.3	14	112	106	0.8	305	800	1.8	7.6	141

Figure 30. Corrosion of Galvanized Steel, Site A<sub>1</sub> Run I, Soft Water Plus Added Chloride and Sulfate



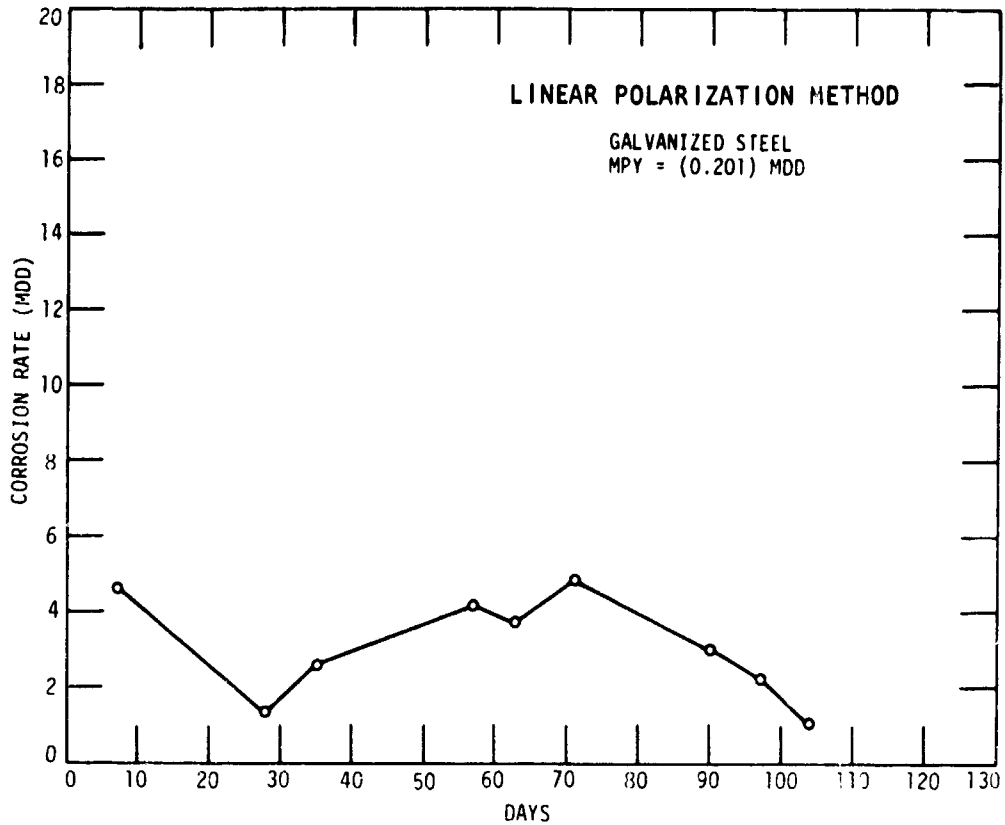

VELOCITY AND DIAMETER	GALVANIZED CORROSION BY WEIGHT LOSS (ASTM, D 2688-C) MDD		
	28 days	93 days	121 days
1" dia 1.3 ft/sec	78	20	24
1/2" dia 4.8 ft/sec	45	22	19

TIME days	CREVICE CORROSION BY WEIGHT LOSS (ASTM, D 2688-C) MDD VELOCITY: 1.3 ft/sec		
	1" Zn	1" Zn	2" Zn
28	72	80	74
93	21	31	32
121	22	26	23

AVERAGE ANALYSIS (ppm)															
Iron (Fe)	Copper (Cu)	Zinc (Zn)	Calcium (Ca)	Magnesium (Mg)	Hardness (as CaCO <sub>3</sub> )	Phosphate (as total P <sub>04</sub> )	Silica (SiO <sub>2</sub> )	Chloride (Cl)	Sulphate (SO <sub>4</sub> )	Nitrate (NO <sub>3</sub> )	Alkalinity (as CaCO <sub>3</sub> )	Dissolved Solids	Dissolved Oxygen	pH	Temperature (°F)
0.4	.03	.50	1.0	0.7	3	0.7	23	131	111	0.6	357	667	2.7	8.0	143

Figure 31. Corrosion of Galvanized Steel, Site A<sub>1</sub>  
Run II, Soft Water Plus Added Chloride,  
Sulfate, and 11 ppm Silica, pH 8.0

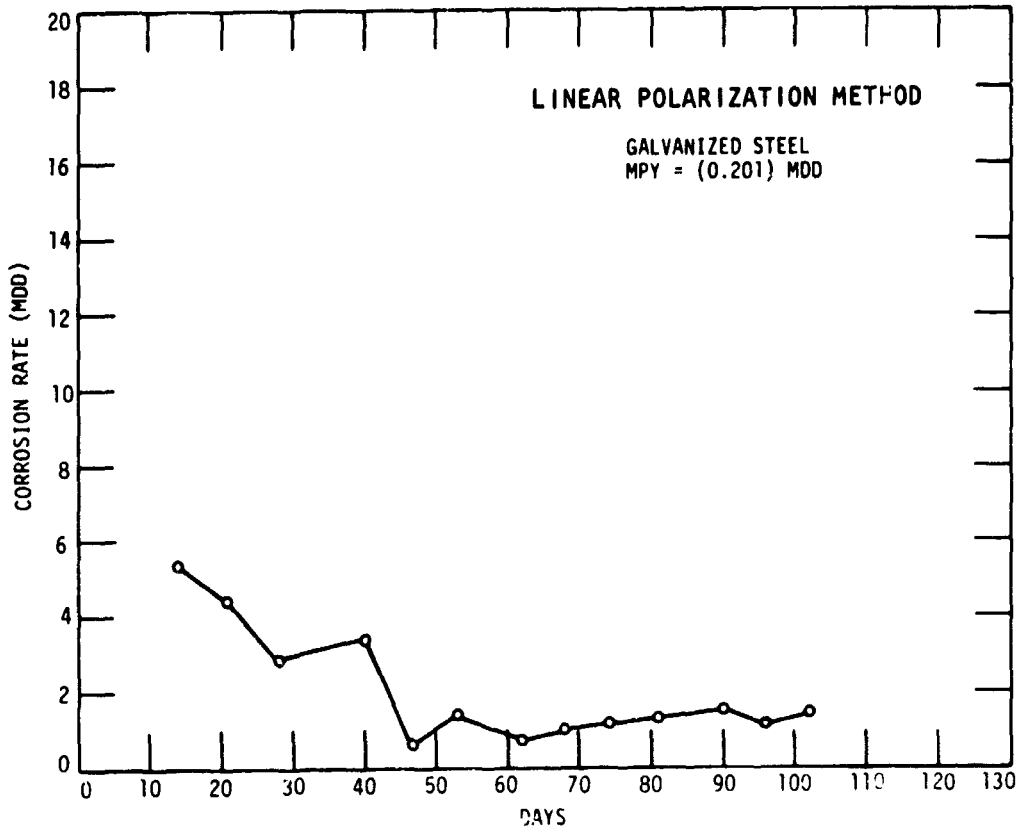

VELOCITY AND DIAMETER	GALVANIZED CORROSION BY WEIGHT LOSS (ASTM, D 2688-C) MDD		
	28 days	74 days	102 days
1" dia 1.3 ft/sec	66	31	20
½" dia 4.8 ft/sec	116	19	24

TIME days	CREVICE CORROSION BY WEIGHT LOSS (ASTM, D 2688-C) MDD VELOCITY: 1.3 ft/sec			
	½"Fe	1"Zn	½"Fe	2"Zn
28	184	241	146	167
74	81	44	44	42
102	50	44	61	37

AVERAGE ANALYSIS (ppm)															
Iron (Fe)	Copper (Cu)	Zinc (Zn)	Calcium (Ca)	Magnesium (Mg)	Hardness (as CaCO <sub>3</sub> )	Phosphate (as Total P <sub>04</sub> )	Silica (SiO <sub>2</sub> )	Chloride (Cl)	Sulphate (SO <sub>4</sub> )	Nitrate (NO <sub>3</sub> )	Alkalinity (as CaCO <sub>3</sub> )	Dissolved Solids	Dissolved Oxygen	pH	Temperature (°F)
0.2	.01	.20	24	12	117	0.6	21	109	94	0.0	338	703	1.7	8.1	117

Figure 32. Corrosion of Galvanized Steel, Site A<sub>1</sub>  
Run III, Blended Hardness Plus Added Chloride,  
Sulfate, and 11 ppm Silica, pH 8.1

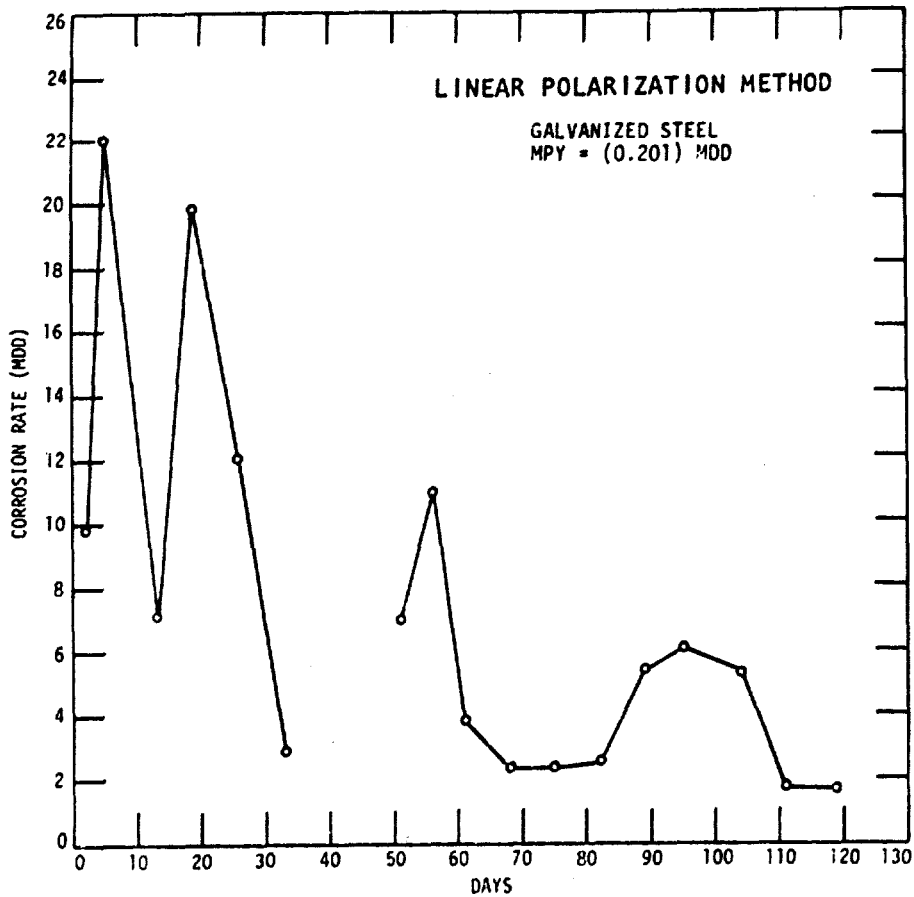

VELOCITY AND DIAMETER	GALVANIZED CORROSION: BY WEIGHT LOSS (ASTM, D 2688-C) MDD		
	29 days	90 days	119 days
1" dia 1.3 ft/sec	37	14	8.2
1" dia 4.8 ft/sec	16	12	6.6

TIME days	CREVICE CORROSION BY WEIGHT LOSS (ASTM, D 2688-C) MDD VELOCITY: 1.3 ft/sec		
	1" Zn	1" Zn	1" Zn
29	34	41	38
90	26	21	22
119	10	9	11

AVERAGE ANALYSIS (ppm)															
Iron (Fe)	Copper (Cu)	Zinc (Zn)	Calcium (Ca)	Magnesium (Mg)	Hardness (as CaCO <sub>3</sub> )	Phosphate (as Total PO <sub>4</sub> )	Silica (SiO <sub>2</sub> )	Chloride (Cl)	Sulphate (SO <sub>4</sub> )	Nitrate (NO <sub>3</sub> )	Alkalinity (as CaCO <sub>3</sub> )	Dissolved Solids	Dissolved Oxygen	pH	Temperature (°F)
0.6	.02	.63	1.0	0.8	5	0.3	13	116	106	0.7	306	755	0.9	7.7	71

Figure 33. Corrosion of Galvanized Steel, Site A<sub>2</sub> Run I, Soft Water Plus Added Chloride and Sulfate<sup>2</sup>

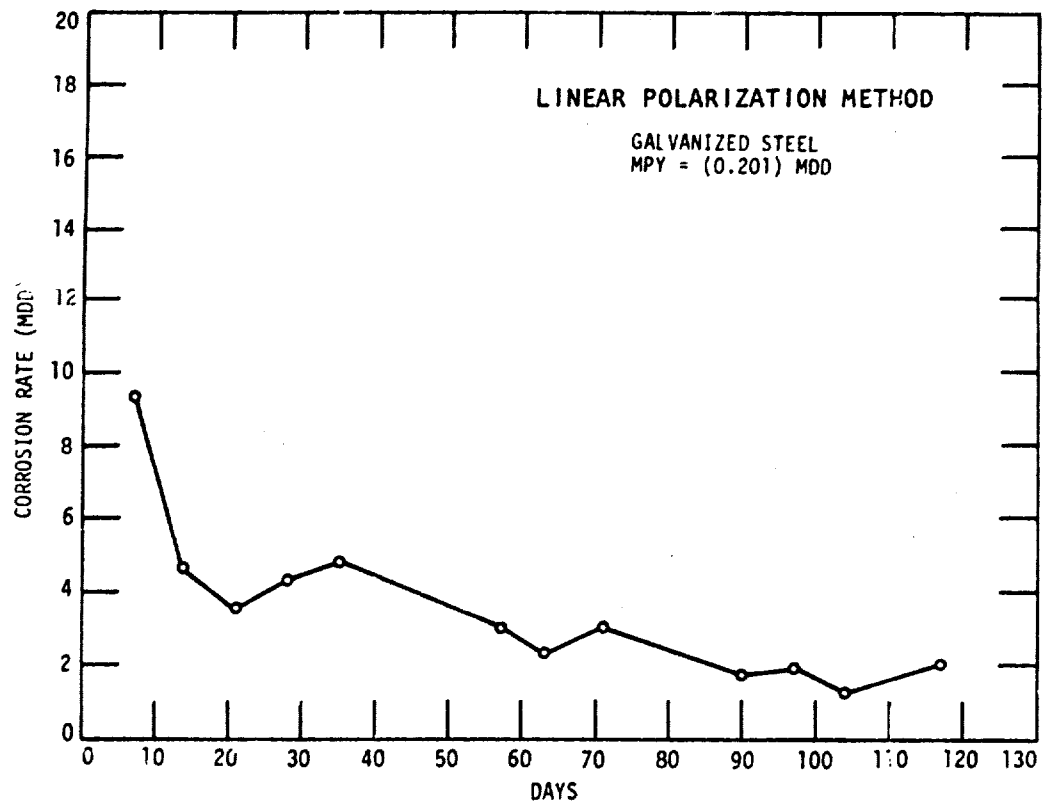

VELOCITY AND DIAMETER	GALVANIZED CORROSION BY WEIGHT LOSS (ASTM, D 2688-C) MDD		
	28 days	93 days	121 days
1" dia 1.3 ft/sec	52	26	13
1/2" dia 4.8 ft/sec	--	36	16

TIME days	CREVICE CORROSION BY WEIGHT LOSS (ASTM, D 2688-C) MDD VELOCITY: 1.3 ft/sec		
	1" Zn	1" Zn	2" Zn
28	96	95	53
93	20	18	43
121	22	27	24

AVERAGE ANALYSIS (ppm)															
Iron (Fe)	Copper (Cu)	Zinc (Zn)	Calcium (Ca)	Magnesium (Mg)	Hardness (as CaCO <sub>3</sub> )	Phosphate (as Total P <sub>04</sub> )	Silica (SiO <sub>2</sub> )	Chloride (Cl)	Sulphate (SO <sub>4</sub> )	Nitrate (NO <sub>3</sub> )	Alkalinity (as CaCO <sub>3</sub> )	Dissolved Solids	Dissolved Oxygen	pH	Temperature (°F)
0.4	.02	.34	0.7	0.8	4	0.7	31	115	102	0.7	360	672	1.4	8.3	168

Figure 34. Corrosion of Galvanized Steel, Site A<sub>2</sub> Run II, Soft Water Plus Added Chloride, Sulfate, and 20 ppm Silica, pH 8.3

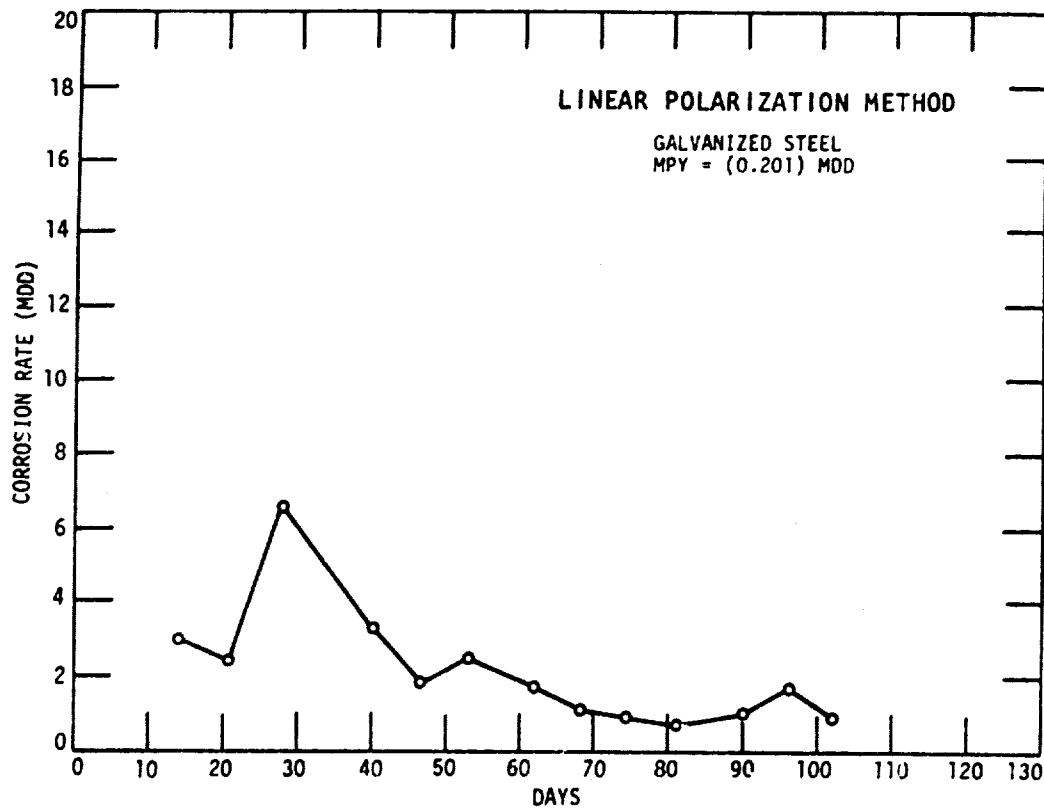

VELOCITY AND DIAMETER	GALVANIZED CORROSION BY WEIGHT LOSS (ASTM, D 2688-C) MDD		
	28 days	74 days	102 days
1" dia 1.3 ft/sec	110	4.2	17
1/2" dia 4.8 ft/sec	62	15	7.5

TIME days	CREVICE CORROSION BY WEIGHT LOSS (ASTM, D 2688-C) MDD VELOCITY: 1.3 ft/sec			
	1/2"Fe	1"Zn	1/2"Fe	2"Zn
28	25	87	3.1	220
74	73	14	44	39
102	28	33	52	21

AVERAGE ANALYSIS (ppm)															
Iron (Fe)	Copper (Cu)	Zinc (Zn)	Calcium (Ca)	Magnesium (Mg)	Hardness (as CaCO <sub>3</sub> )	Phosphate (as Total PO <sub>4</sub> )	Silica (SiO <sub>2</sub> )	Chloride (Cl)	Sulphate (SO <sub>4</sub> )	Nitrate (NO <sub>3</sub> )	Alkalinity (as CaCO <sub>3</sub> )	Dissolved Solids	Dissolved Oxygen	pH	Temperature (°F)
0.2	.07	.50	24	13	117	0.6	37	112	94	0.0	349	715	0.8	8.2	167

Figure 35. Corrosion of Galvanized Steel, Site A<sub>2</sub> Run III, Blended Hardness, Added 25 ppm Silica, and 2 ppm Tannin, pH 8.2

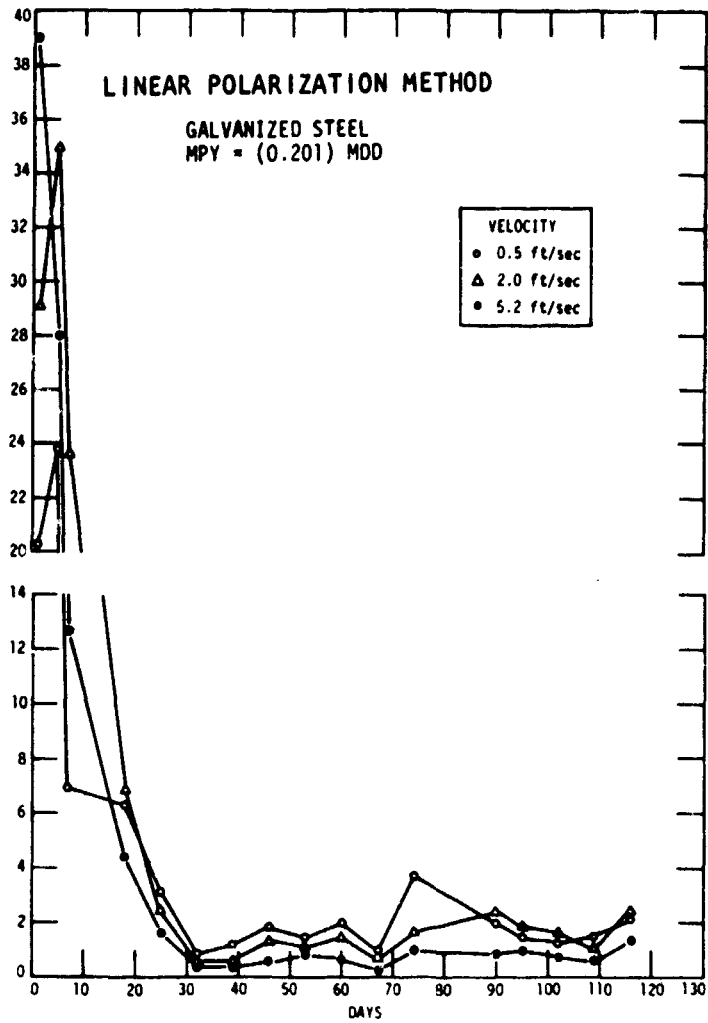

VELOCITY ft/sec	GALVANIZED CORROSION BY WEIGHT LOSS (ASTM, D 2688-C) MDD		
	29 days	91 days	120 days
0.5	18	12	8.7
2.0	19	9.4	9.5
5.2	18	1.0	11

CORROSION BY WEIGHT LOSS (ASTM, D 2688-C) MDD		
DAYS-120 VELOCITY: 2.0 ft/sec		
CREVICE		
5.3	4.9	7.7
1"Zn	1"Zn	2"Zn
GALVANIC		
2.3	7.6	1.4
1"Cu	1"Zn	1"Cu

AVERAGE ANALYSIS (ppm)															
Iron (Fe)	Copper (Cu)	Zinc (Zn)	Calcium (Ca)	Magnesium (Mg)	Hardness (as CaCO <sub>3</sub> )	Phosphate (as PO <sub>4</sub> )	Silica (SiO <sub>2</sub> )	Chloride (Cl)	Sulfate (SO <sub>4</sub> )	Nitrate (NO <sub>3</sub> )	Alkalinity (as CaCO <sub>3</sub> )	Dissolved Solids	Dissolved Oxygen	pH	Temperature (°F)
1.4	0.02	45	68	26	285	5.1	25	102	105	4.0	146	26	8.0	7	142

Figure 36. Corrosion of Galvanized Steel, Site B<sub>1</sub>  
Run I, Hard Water Plus Added Chloride,  
Sulfate, 18 ppm Silica, and 5 ppm Polyphosphate

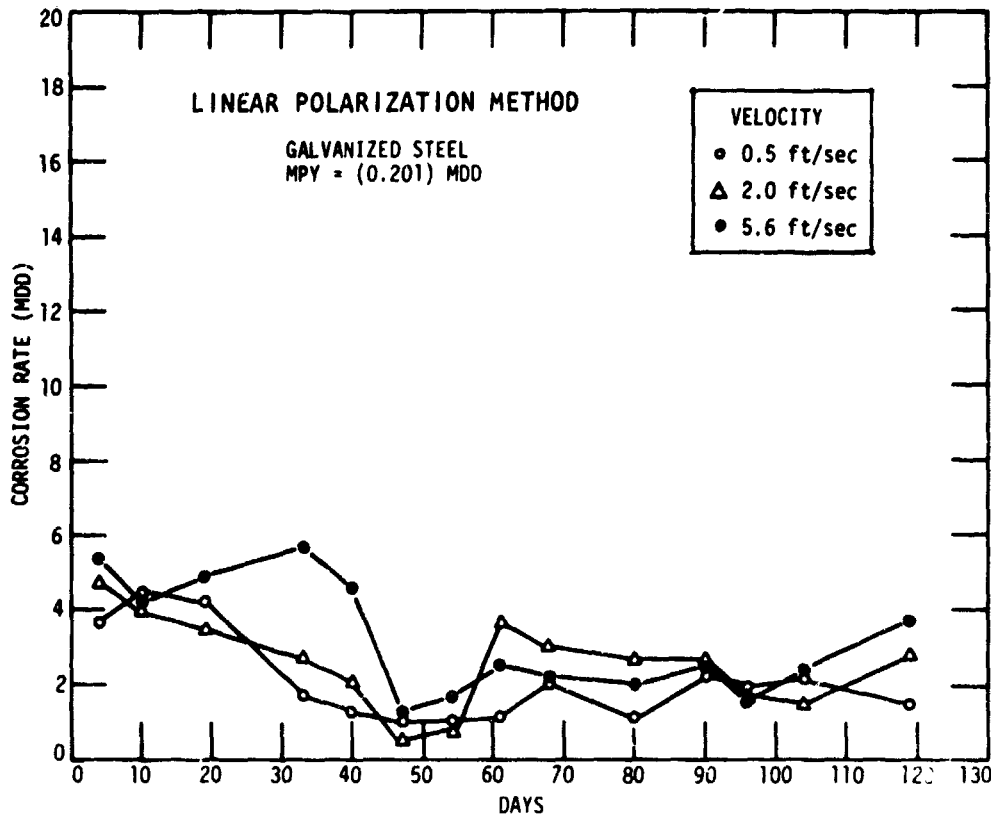

VELOCITY ft/sec	GALVANIZED CORROSION BY WEIGHT LOSS (ASTM, D 2688-C) MDD		
	27 days	92 days	119 days
0.5	6.4	4.0	2.6
2.0	11	12	8.2
5.6	4.6	15	10

**CORROSION BY WEIGHT LOSS**  
(ASTM, D 2688-C) MDD

DAYS: 119 VELOCITY: 2.0 ft/sec  
CREVICE

10	10	6.6
1"Zn	1"Zn	2"Zn

GALVANIC

22	11	19	9.1
1"Cu	1"Zn	1"Cu	1"Zn

AVERAGE ANALYSIS (ppm)															
Iron (Fe)	Copper (Cu)	Zinc (Zn)	Calcium (Ca)	Magnesium (Mg)	Hardness (as CaCO <sub>3</sub> )	Phosphate (as Total)	Silica (SiO <sub>2</sub> )	Chloride (Cl)	Sulphate (SO <sub>4</sub> )	Nitrate (NO <sub>3</sub> )	Alkalinity (as CaCO <sub>3</sub> )	Dissolved Solids	Dissolved Oxygen	pH	Temperature (°F)
0.3	.02	.23	26	23	197	0.2	16	4	1	4.5	344	397	4.4	7.7	140

Figure 37. Corrosion of Galvanized Steel,  
Site B1 Run II, Hard Water

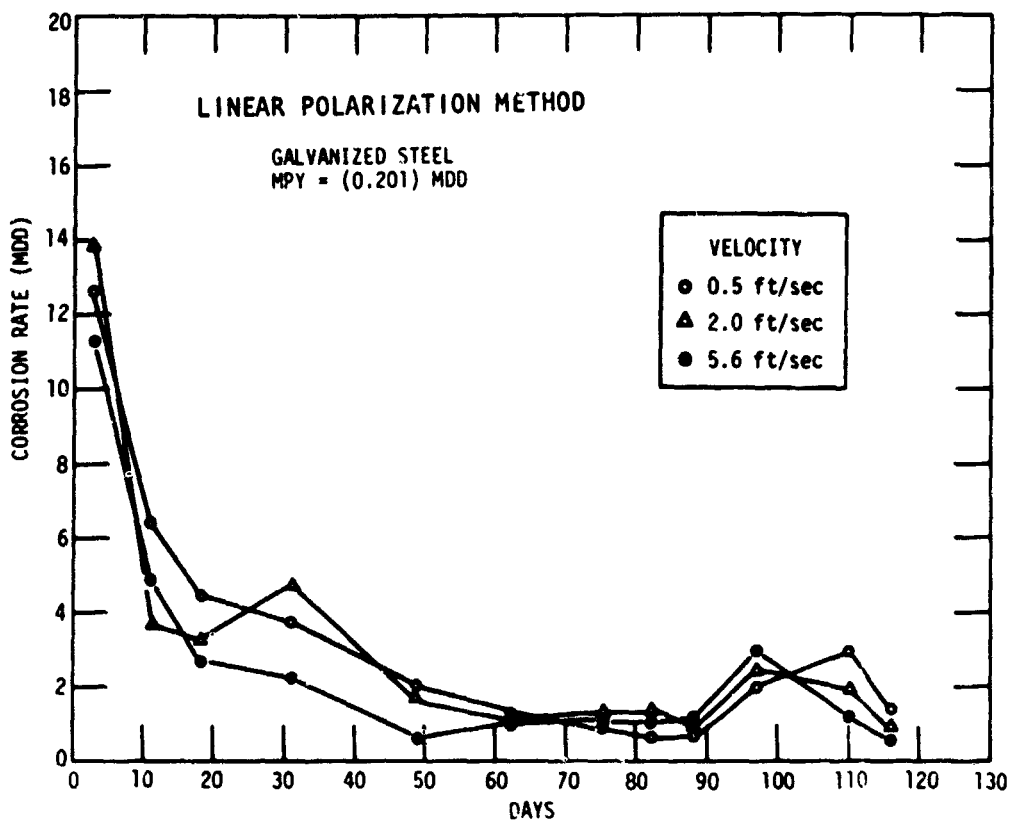

VELOCITY ft/sec	GALVANIZED CORROSION BY WEIGHT LOSS (ASTM, D 2688-C) MDD		
	28 days	94 days	122 days
0.5	25	31	19
2.0	30	38	30
5.6	55	26	24

CORROSION BY WEIGHT LOSS (ASTM, D 2688-C) MDD			
DAYS: 122		VELOCITY: 2.0 ft/sec	
CREVICE			
37	34	27	30
1/2"Fe	1"Zn	1/2"Fe	2"Zn
GALVANIC			
17	40	6.4	11
1"Cu	1"Zn	1"Cu	1"Zn

AVERAGE ANALYSIS (ppm)															
Iron (Fe)	Copper (Cu)	Zinc (Zn)	Calcium (Ca)	Magnesium (Mg)	Hardness (as CaCO <sub>3</sub> )	Phosphate (as Total PO <sub>4</sub> )	Silica (SiO <sub>2</sub> )	Chloride (Cl)	Sulfate (SO <sub>4</sub> )	Nitrate (NO <sub>3</sub> )	Alkalinity (as CaCO <sub>3</sub> )	Dissolved Solids	Dissolved Oxygen	pH	Temperature (°F)
0.5	.03	.17	33	18	140	1.4	14	96	85	3.4	367	669	5.7	8.3	141

Figure 38. Corrosion of Galvanized Steel, Site B<sub>1</sub> Run III, Hard Water Plus Added Chloride, Sulfate, and Caustic Soda, pH 8.0



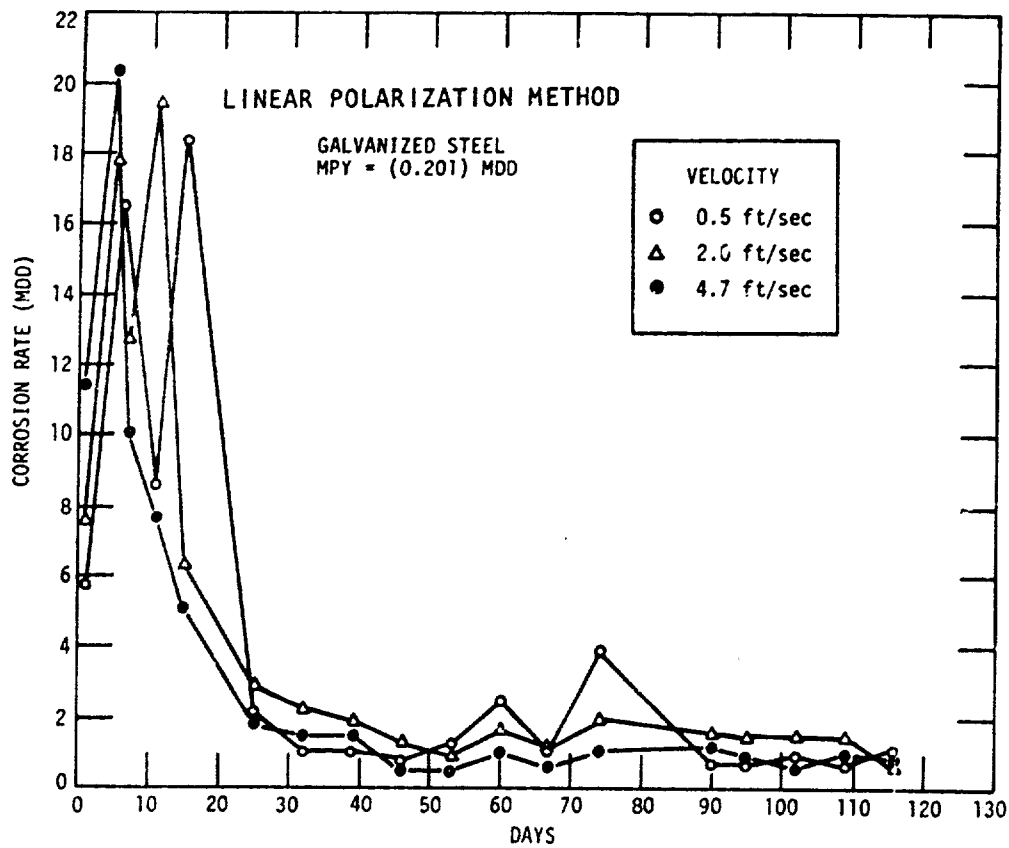

VELOCITY ft/sec	GALVANIZED CORROSION BY WEIGHT LOSS (ASTM, D 2638-C) MDD		
	29 days	91 days	120days
0.5	30	12	5.4
2.0	41	21	15
4.7	33	18	12

CORROSION BY WEIGHT LOSS (ASTM, D 2688-C) MDD		
DAYS: 120 VELOCITY: 2.0 ft/sec		
CREVICE		
6.6	8.0	5.5
1"Zn	1"Zn	2"
GALVANIC		
1.9	18	1.4
1"Cu	1"Zn	1"Cu

AVERAGE ANALYSIS (ppm)															
Iron (Fe)	Copper (Cu)	Zinc (Zn)	Calcium (Ca)	Magnesium (Mg)	Hardness (as CaCO <sub>3</sub> )	Phosphate (as total PO <sub>4</sub> )	Silica (SiO <sub>2</sub> )	Chloride (Cl)	Sulphate (SO <sub>4</sub> )	Nitrate (NO <sub>3</sub> )	Alkalinity (as CaCO <sub>3</sub> )	Dissolved Solids	Dissolved Oxygen	pH	Temperature (°F)
1.2	.02	.34	64	26	266	7.5	30	104	103	4.2	341	620	2.1	7.8	180

Figure 39. Corrosion of Galvanized Steel, Site B<sub>2</sub> Run I, Hard Water Plus Added Chloride and Sulfate, 18 ppm Silica, and 6 ppm Polyphosphate

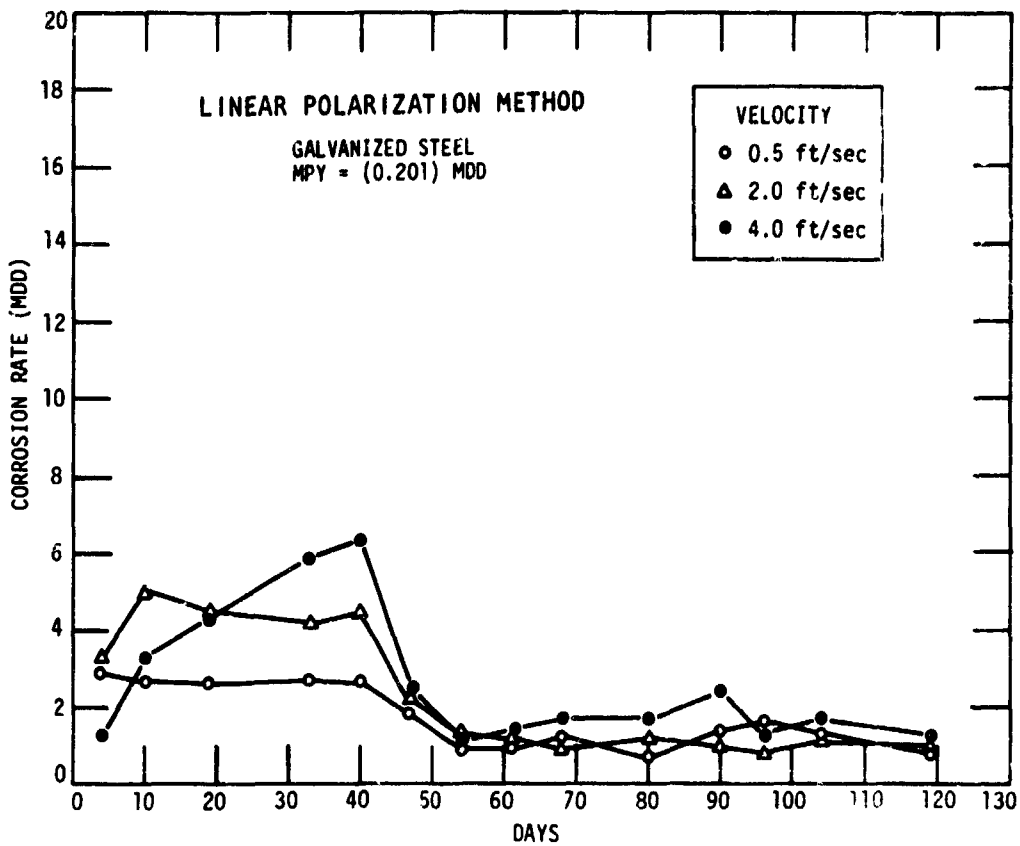

VELOCITY ft/sec	GALVANIZED CORROSION BY WEIGHT LOSS (ASTM, D 2688-C) MDD		
	27 days	92 days	119 days
0.5	9.5	1.9	1.4
2.0	5.8	3.2	---
4.0	3.9	7.2	2.4

CORROSION BY WEIGHT LOSS (ASTM, D 2688-C) MDD			
DAYS: 119		VELOCITY: 2.0 ft/sec	
CREVICE			
1.8	3.1	1.9	
1"Zn	1"Zn	2"Zn	
GALVANIC			
32	6.5	21	7.6
1"Cu	1"Zn	1"Cu	1"Zn

AVERAGE ANALYSIS (ppm)															
Iron (Fe)	Copper (Cu)	Zinc (Zn)	Calcium (Ca)	Magnesium (Mg)	Hardness (as CaCO <sub>3</sub> )	Phosphate (as Total PO <sub>4</sub> )	Silica (SiO <sub>2</sub> )	Chloride (Cl)	Sulphate (SO <sub>4</sub> )	Nitrate (NO <sub>3</sub> )	Alkalinity (as CaCO <sub>3</sub> )	Dissolved Solids	Dissolved Oxygen	pH	Temperature (°F)
0.3	.03	.30	27	25	170	1.4	15	4	1	4.4	342	393	3.6	7.7	178

Figure 40. Corrosion of Galvanized Steel, Site B2 Run II, Hard Water

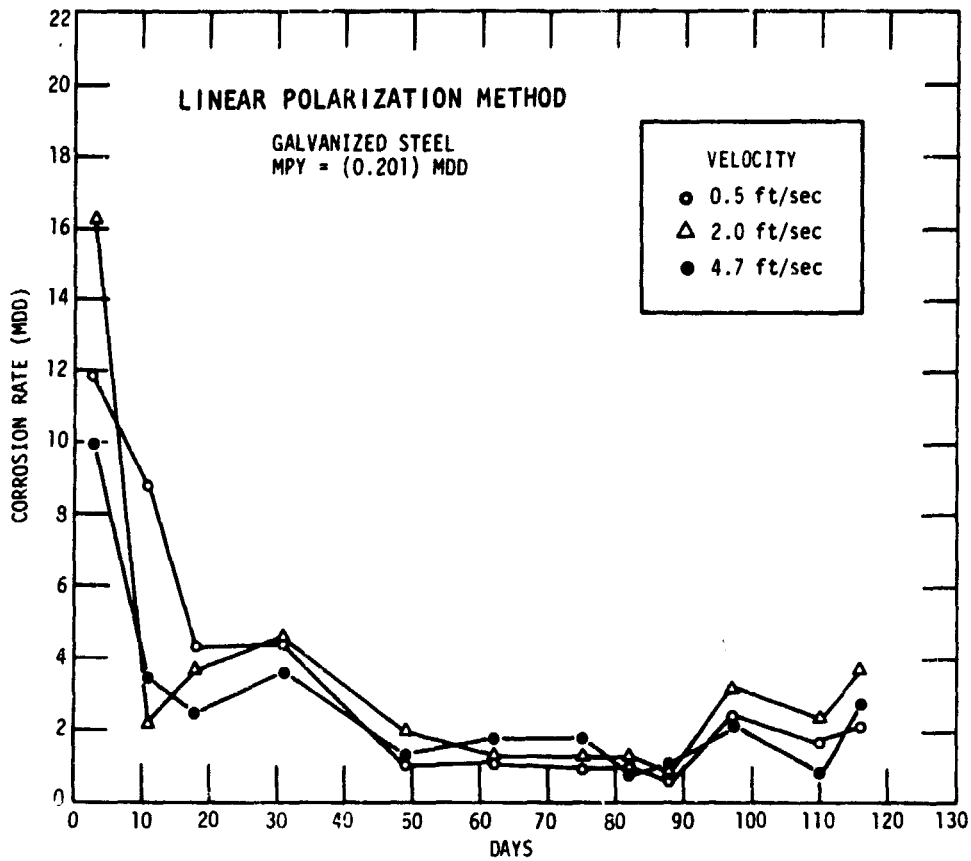

VELOCITY ft/sec	GALVANIZED CORROSION BY WEIGHT LOSS (ASTM, D 2688-C) MDD		
	28 days	94 days	122 days
0.5	66	44	18
2.0	79	58	41
4.7	29	62	40

CORROSION BY WEIGHT LOSS (ASTM, D 2688-C) MDD			
DAYS: 122		VELOCITY: 2.0 ft/sec	
CREVICE			
57	22	50	25
1/2" Fe	1" Zn	1/2" Fe	2" Zn
GALVANIC			
30	45	6.6	4
1" Cu	1" Zn	1" Cu	1" Zn

AVERAGE ANALYSIS (ppm)															
Iron (Fe)	Copper (Cu)	Zinc (Zn)	Calcium (Ca)	Magnesium (Mg)	Hardness (as CaCO <sub>3</sub> )	Phosphate (as Total PO <sub>4</sub> )	Silica (SiO <sub>2</sub> )	Chloride (Cl)	Sulphate (SO <sub>4</sub> )	Nitrate (NO <sub>3</sub> )	Alkalinity (as CaCO <sub>3</sub> )	Dissolved Solids	Dissolved Oxygen	pH	Temperature (°F)
0.4	.04	.16	29	18	145	1.4	15	95	81	3.3	357	655	2.8	8.0	179

Figure 41. Corrosion of Galvanized Steel, Site B<sub>2</sub> Run III, Hard Water Plus Added Chloride, Sulfate, and Caustic Soda, pH 8.0

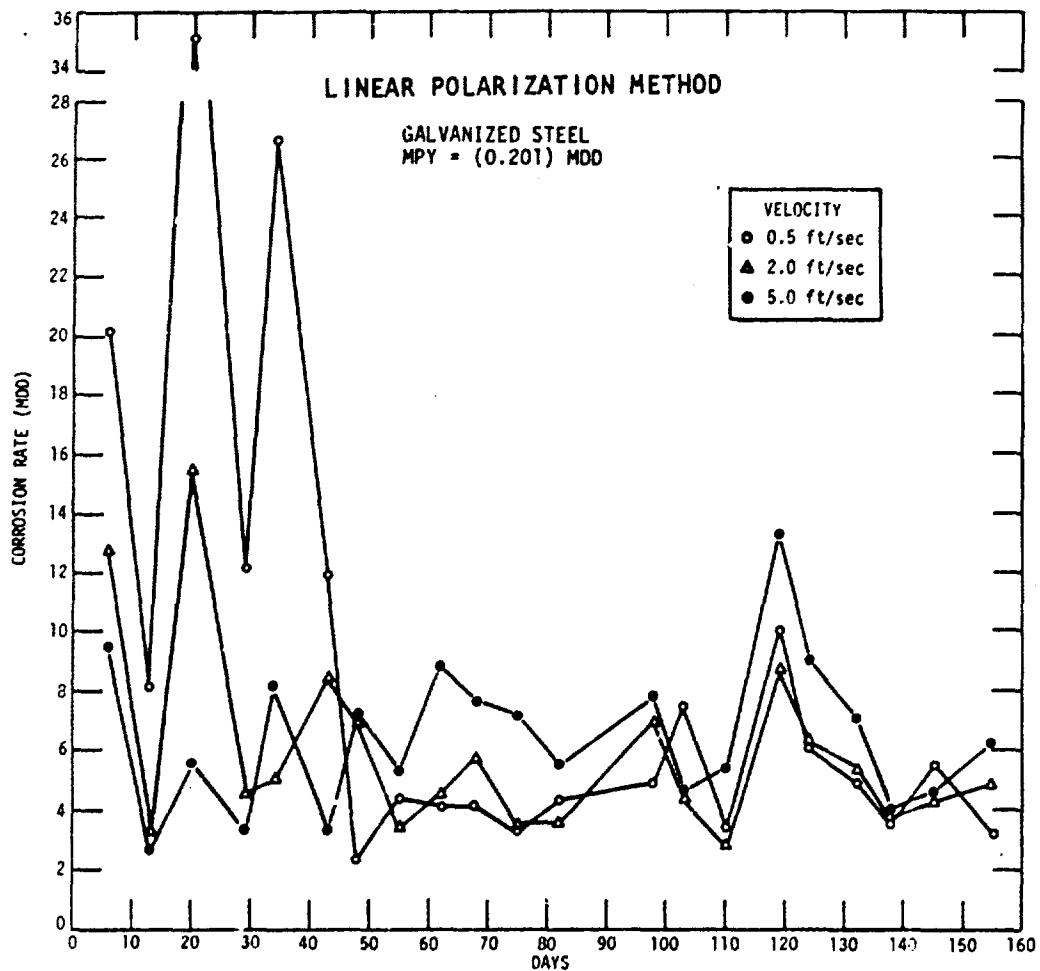

VELOCITY ft/sec	GALVANIZED CORROSION BY WEIGHT LOSS (ASTM, D 2688-C) MDD		
	33 days	86 days	119 days
0.5	33	8.2	16
2.0	33	27	21
5.0	42	35	25

CORROSION BY WEIGHT LOSS (ASTM, D 2688-C) MDD					
DAYS: 124 VELOCITY: 2.0 ft/sec					
CREVICE					
20	21	15			
1"Zn	1"Zn	2"Zn			
GALVANIC					
0.2	24	0.1	26		
1"Cu	1"Zn	1"Cu	1"Zn		

AVERAGE ANALYSIS (ppm)															
Iron (Fe)	Copper (Cu)	Zinc (Zn)	Calcium (Ca)	Magnesium (Mg)	Hardness (as CaCO <sub>3</sub> )	Phosphate (as Total PO <sub>4</sub> )	Silica (SiO <sub>2</sub> )	Chloride (Cl)	Sulphate (SO <sub>4</sub> )	Nitrate (NO <sub>3</sub> )	Alkalinity (as CaCO <sub>3</sub> )	Dissolved Solids	Dissolved Oxygen	pH	Temperature (°F)
0.3	.18	.25	3.5	1.3	16	0.0	7	19	51	8.	247	403	2.0	7.6	133

Figure 42. Corrosion of Galvanized Steel, Site C<sub>1</sub> Run I, Soft Water

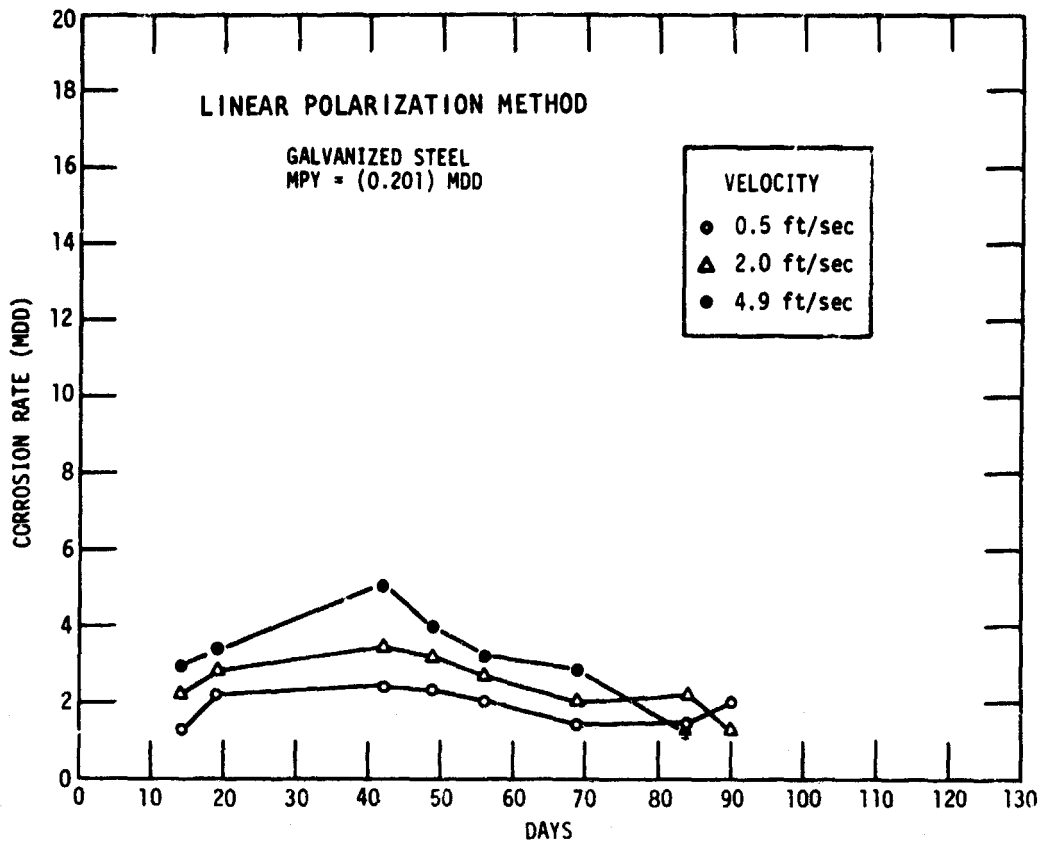

VELOCITY ft/sec	GALVANIZED CORROSION BY WEIGHT LOSS (ASTM, D 2688-C) MDD		
	28 days	62 days	90 days
0.5	9.3	4.4	3.8
2.0	19	14	7.9
4.9	20	7.4	19

CORROSION BY WEIGHT LOSS (ASTM, D 2688-C) MDD			
DAYS: 90		VELOCITY: 2.0 ft/sec	
CREVICE			
8.2	7.9	6.4	
1"Cu	1"Zn	2"Zn	
GALVANIC			
0.2	11	0.7	11
1"Cu	1"Zn	1"Cu	1"Zn

AVERAGE ANALYSIS (ppm)															
Iron (Fe)	Copper (Cu)	Zinc (Zn)	Calcium (Ca)	Magnesium (Mg)	Hardness (as CaCO <sub>3</sub> )	Phosphate (as Total PO <sub>4</sub> )	Silica (SiO <sub>2</sub> )	Chloride (Cl)	Sulphate (SO <sub>4</sub> )	Nitrate (NO <sub>3</sub> )	Alkalinity (as CaCO <sub>3</sub> )	Dissolved Solids	Dissolved Oxygen	pH	Temperature (°F)
0.0	.14	.04	12	7	62	0.0	13	21	44	3.9	275	413	1.4	8.0	143

Figure 43. Corrosion of Galvanized Steel, Site C<sub>1</sub>, Run II, Blended Hardness, Added 10 ppm Silica, pH 8.0

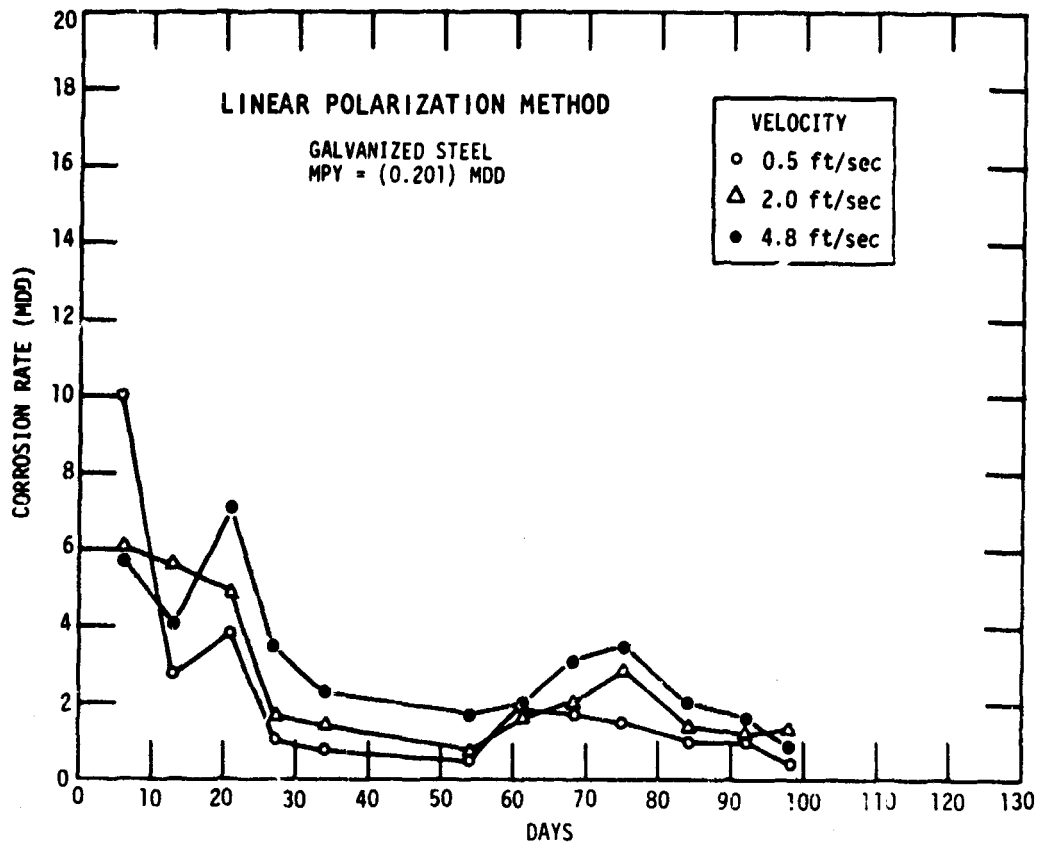

VELOCITY ft/sec	GALVANIZED CORROSION BY WEIGHT LOSS (ASTM, D 2688-C) MDD		
	27 days	71 days	98 days
0.5	29	16	12
2.0	29	22	15
4.8	37	24	20

CORROSION BY WEIGHT LOSS (ASTM, D 2688-C) MDD			
DAYS: 98		VELOCITY: 2.0 ft/sec	
CREVICE			
41	23	-	17
1"Fe	1"Zn	1"Fe	1"Zn
GALVANIC			
13	18	9.4	24
1"Cu	1"Zn	1"Cu	1"Zn

AVERAGE ANALYSIS (ppm)															
Iron (Fe)	Copper (Cu)	Zinc (Zn)	Calcium (Ca)	Magnesium (Mg)	Hardness (as CaCO <sub>3</sub> )	Phosphate (as Total PO <sub>4</sub> )	Silica (SiO <sub>2</sub> )	Chloride (Cl)	Sulphate (SO <sub>4</sub> )	Nitrate (NO <sub>3</sub> )	Alkalinity (as CaCO <sub>3</sub> )	Dissolved Solids	Dissolved Oxygen	Temperature (°F)	
0.1	.15	.04	2.5	1.2	10	0.0	11	21	42	1.0	286	444	0.6	8.1	144

Figure 44. Corrosion of Galvanized Steel, Site C<sub>1</sub> Run III, Soft Water, Added 6 ppm Silica, and 3.5 ppm Tannin, pH 8.1

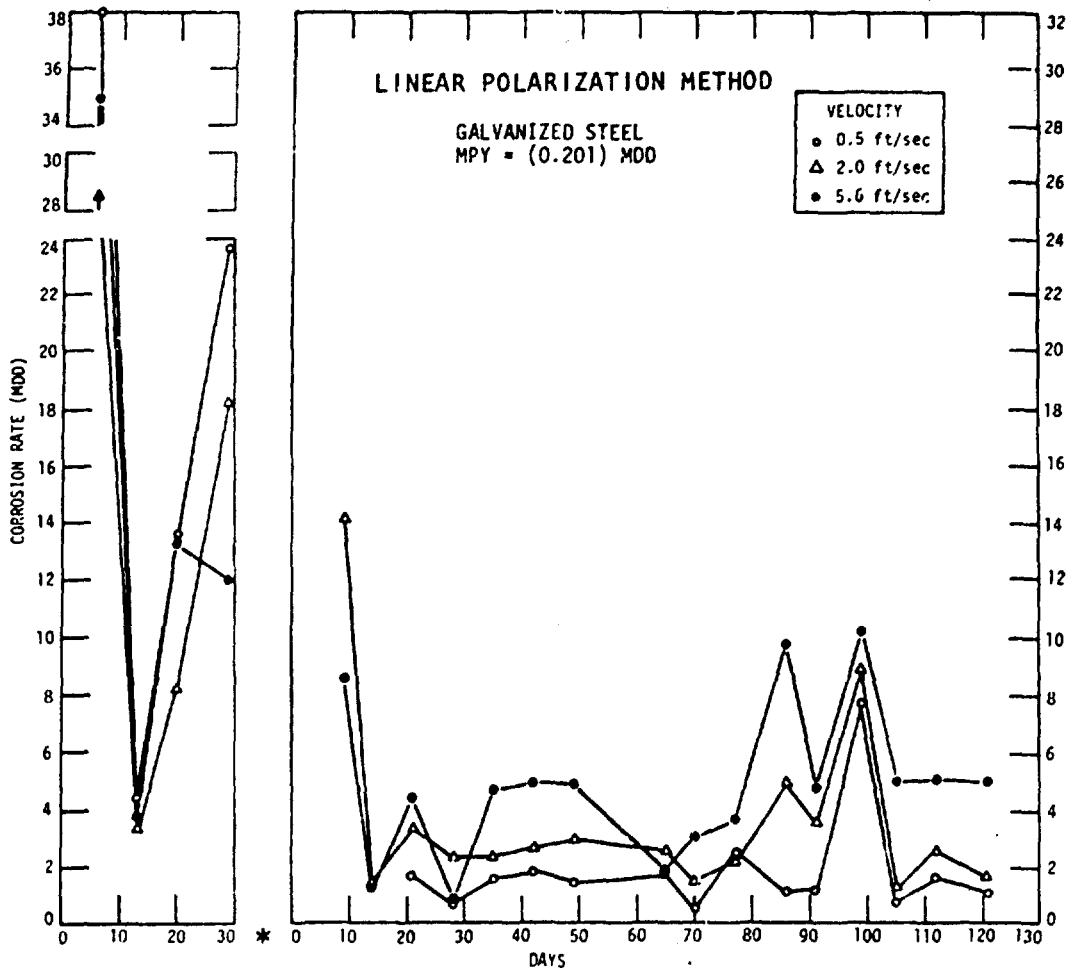

VELOCITY ft/sec	GALVANIZED CORROSION BY WEIGHT LOSS (ASTM, D 2688-C) MDD		
	26 days	91 days	119 days
0.5	42	7.6	5.2
2.0	50	16	5.7
5.6	68	23	16

CORROSION BY WEIGHT LOSS (ASTM, D 2688-C) MDD		
DAYS: 124 VELOCITY: 2.0 ft/sec		
CREVICE		
21	20	18
1"Zn	1"Zn	2"Zn
GALVANIC		
0.0	23	0.0
1"Cu	1"Zn	1"Cu
	1"Zn	1"Zn

AVERAGE ANALYSIS (ppm)												
Iron (Fe)	Copper (Cu)	Zinc (Zn)	Calcium (Ca)	Magnesium (Mg)	Hardness (as CaCO <sub>3</sub> )	Phosphate (as total PO <sub>4</sub> )	Silica (SiO <sub>2</sub> )	Chloride (Cl)	Sulphate (SO <sub>4</sub> )	Nitrate (NO <sub>3</sub> )	Alkalinity (as CaCO <sub>3</sub> )	Dissolved Solids
0.1	.26	.28	4.0	1.2	19	0.0	7	18	52	7.4	248	388
												Dissolved Oxygen
												2.2
												pH
												7.7
												Temperature (°F)
												126

Figure 45. Corrosion of Galvanized Steel,  
 Site C<sub>2</sub> Run I, Soft Water  
 \* Run Restarted After Velocities Corrected

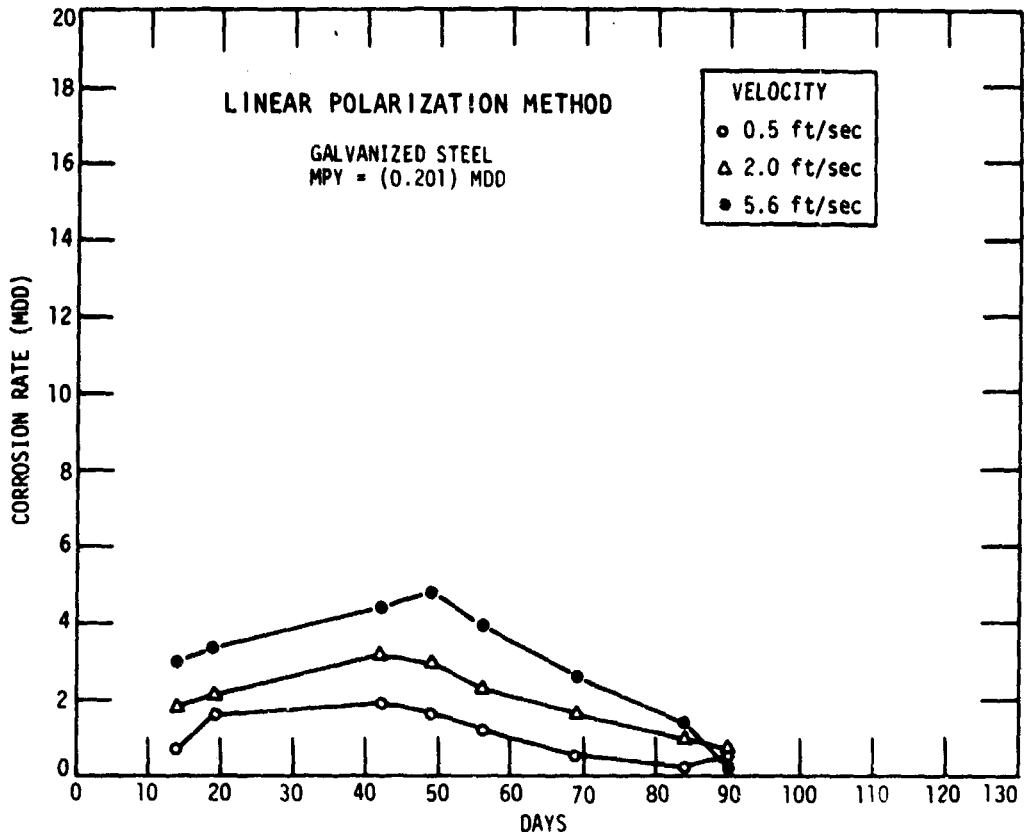

VELOCITY ft/sec	GALVANIZED CORROSION BY WEIGHT LOSS (ASTM, D 2688-C) MDD		
	28 days	62 days	90 days
0.5	16	3.9	2.2
2.0	16	6.5	8.8
5.6	26	10	11

CORROSION BY WEIGHT LOSS (ASTM, D 2688-C) MDD		
DAYS: 90 VELOCITY: 2.0 ft/sec		
CREVICE		
5.3	9.1	5.5
1"Zn	1"Zn	2"Zn
GALVANIC		
1.5	10	3.8
1"Cu	1"Zn	1"Cu 1"Zn

AVERAGE ANALYSIS (ppm)															
Iron (Fe)	Copper (Cu)	Zinc (Zn)	Calcium (Ca)	Magnesium (Mg)	Hardness (as CaCO <sub>3</sub> )	Phosphate (as Total P <sub>04</sub> )	Silica (SiO <sub>2</sub> )	Chloride (Cl)	Sulphate (SO <sub>4</sub> )	Nitrate (NO <sub>3</sub> )	Alkalinity (as CaCO <sub>3</sub> )	Dissolved Solids	Dissolved Oxygen	pH	Temperature (°F)
0.0	.20	.06	15	7	56	0.0	13	20	44	4.9	274	403	1.2	7.8	132

Figure 46. Corrosion of Galvanized Steel, Site C<sub>2</sub> Run II, Blended Hardness, Added 10 ppm Silica, pH 7.8



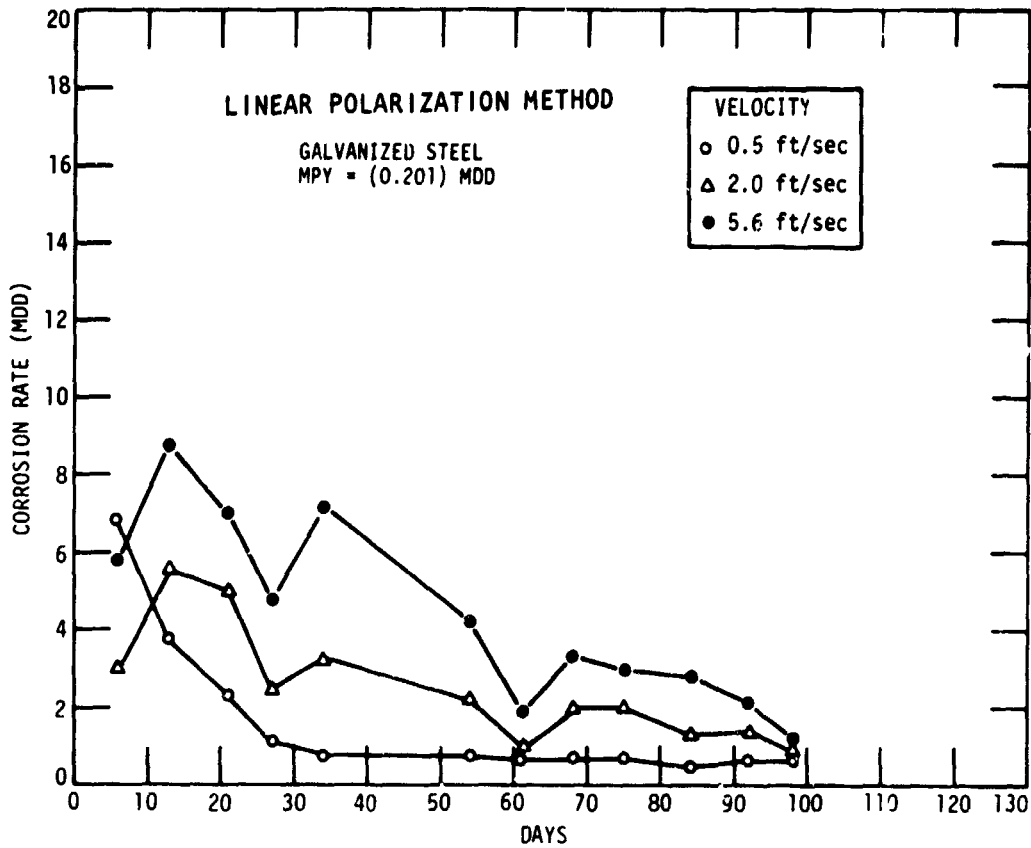

VELOCITY ft/sec	GALVANIZED CORROSION BY WEIGHT LOSS (ASTM, D 2688-C) MDD		
	27 days	71 days	98 days
0.5	29	18	11
2.0	38	23	16
5.6	50	29	16

CORROSION BY WEIGHT LOSS (ASTM, D 2688-C) MDD			
DAYS: 98		VELOCITY: 2.0 ft/sec	
CREVICE			
31	20	31	17
1/2"Fe	1"Zn	1/2"Fe	2"Zn
GALVANIC			
4.4	29	1.8	22
1"Cu	1"Zn	1"Cu	1"Zn

AVERAGE ANALYSIS (ppm)															
Iron (Fe)	Copper (Cu)	Zinc (Zn)	Calcium (Ca)	Magnesium (Mg)	Hardness (as CaCO <sub>3</sub> )	Phosphate (as Total PO <sub>4</sub> )	Silica (SiO <sub>2</sub> )	Chloride (Cl)	Sulphate (SO <sub>4</sub> )	Nitrate (NO <sub>3</sub> )	Alkalinity (as CaCO <sub>3</sub> )	Dissolved Solids	Dissolved Oxygen	pH	Temperature (°F)
0.1	.17	.04	2.6	1.0	10	0.0	11	20	42	1.0	284	437	0.5	8.1	135

Figure 47. Corrosion of Galvanized Steel, Site C<sub>2</sub> Run III, Soft Water, Added 6 ppm Silica, and 3.5 ppm Tannin, pH 8.1

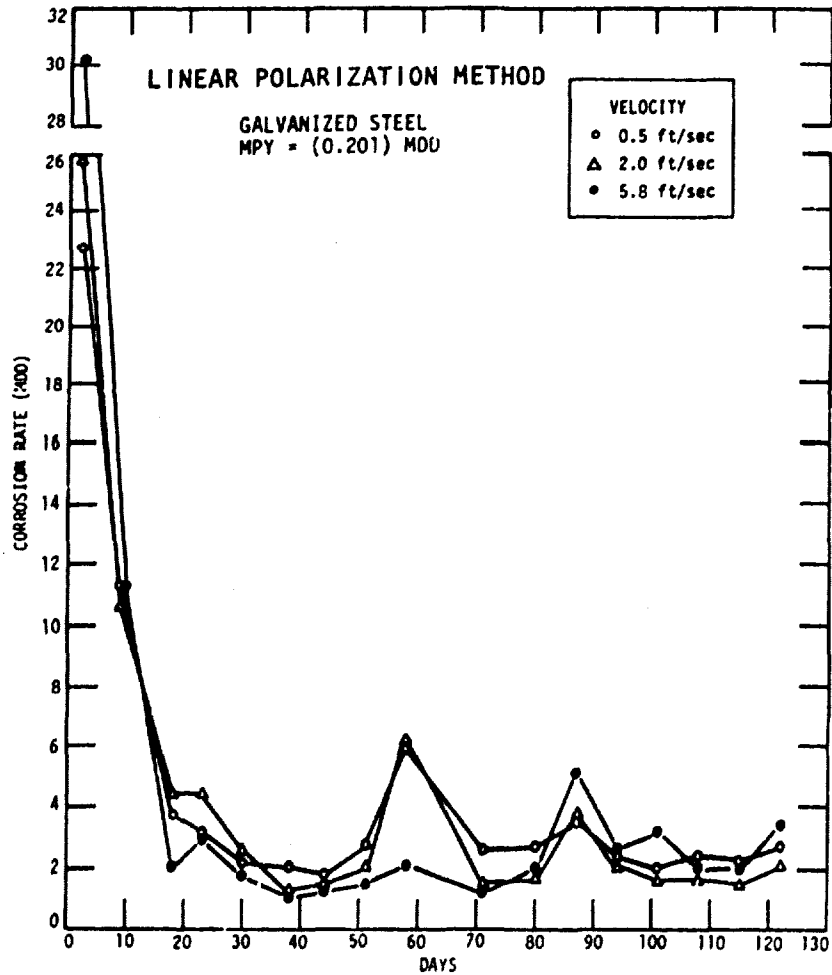

VELOCITY ft/sec	GALVANIZED CORROSION BY WEIGHT LOSS (ASTM, D 2688-C) MDU		
	30 days	92 days	122 days
0.5	15	14	15
2.0	35	25	18
5.8	35	37	24

CORROSION BY WEIGHT LOSS (ASTM, D 2688-C) MDU		
DAYS: 122 VELOCITY: 2.0 ft/sec		
CREVICE		
12	10	9.6
1"Zn	1"Zn	2"Zn
GALVANIC		
0.8	68	0.6
1"Cu	1"Zn	1"Cu

AVERAGE ANALYSIS (ppm)															
Iron (Fe)	Copper (Cu)	Zinc (Zn)	Calcium (Ca)	Magnesium (Mg)	Hardness (as CaCO <sub>3</sub> )	Phosphate (as total PO <sub>4</sub> )	Silica (SiO <sub>2</sub> )	Chloride (Cl)	Sulphate (SO <sub>4</sub> )	Nitrate (NO <sub>3</sub> )	Alkalinity (as CaCO <sub>3</sub> )	Dissolved Solids	Dissolved Oxygen	pH	Temperature (°F)
1.2	.02	.50	15	8	71	0.0	8	431	207	1.1	264	1337	6.3	7.8	132

Figure 48. Corrosion of Galvanized Steel, Site D<sub>1</sub> Run I, Blended Hardness

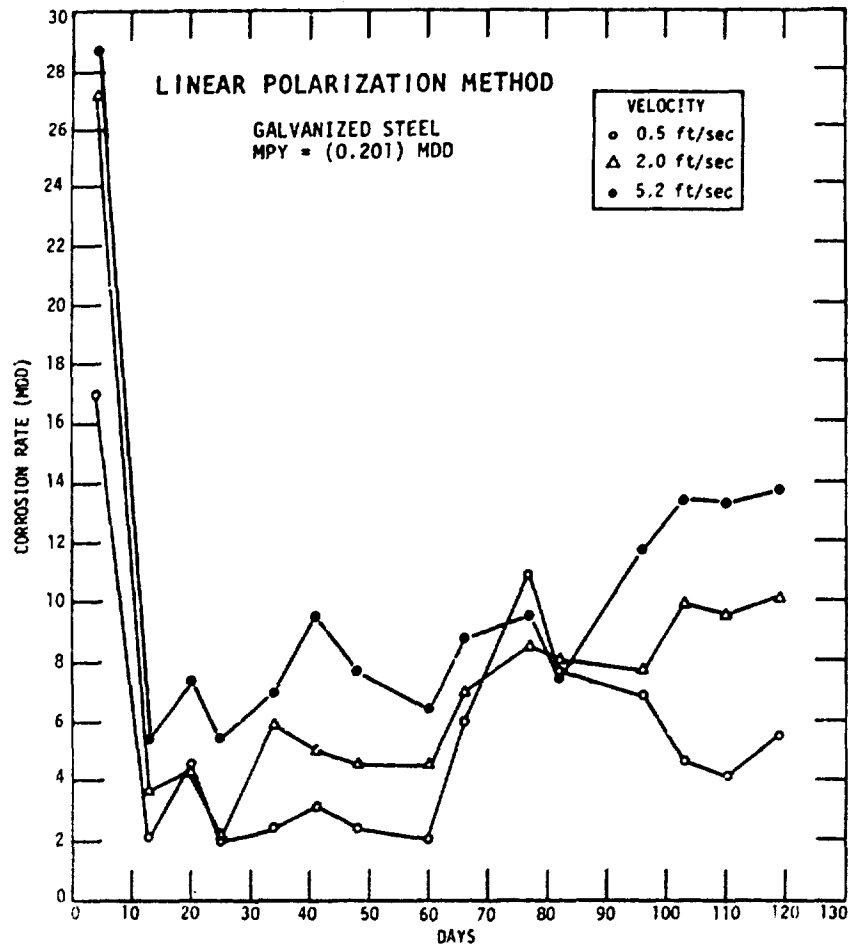

VELOCITY ft/sec	GALVANIZED CORROSION BY WEIGHT LOSS (ASTM, D 2688-C) MDD		
	28 days	91 days	119 days
0.5	32	9.5	12
2.0	37	19	15
5.2	61	23	25

CORROSION BY WEIGHT LOSS (ASTM, D 2688-C) MDD			
DAYS: 119 VELOCITY: 2.0 ft/sec			
CREVICE			
8.6	26	30	
1"Zn	1"Zn	2"Zn	
GALVANIC			
0.8	110	1.6	93
1"Cu	1"Zn	1"Cu	1"Zn

AVERAGE ANALYSIS (ppm)															
Iron (Fe)	Copper (Cu)	Zinc (Zn)	Calcium (Ca)	Magnesium (Mg)	Hardness (as CaCO <sub>3</sub> )	Phosphate (as PO <sub>4</sub> Total)	Silica (SiO <sub>2</sub> )	Chloride (Cl)	Sulphate (SO <sub>4</sub> )	Nitrate (NO <sub>3</sub> )	Alkalinity (as CaCO <sub>3</sub> )	Dissolved Solids	Dissolved Oxygen	pH	Temperature (°F)
0.3	.01	.10	14	8	66	0.0	28	390	201	0.0	281	1338	6.1	8.1	132

Figure 49. Corrosion of Galvanized Steel, Site D<sub>1</sub> Run II, Blended Hardness, Added 22 ppm Silica, pH 8.1

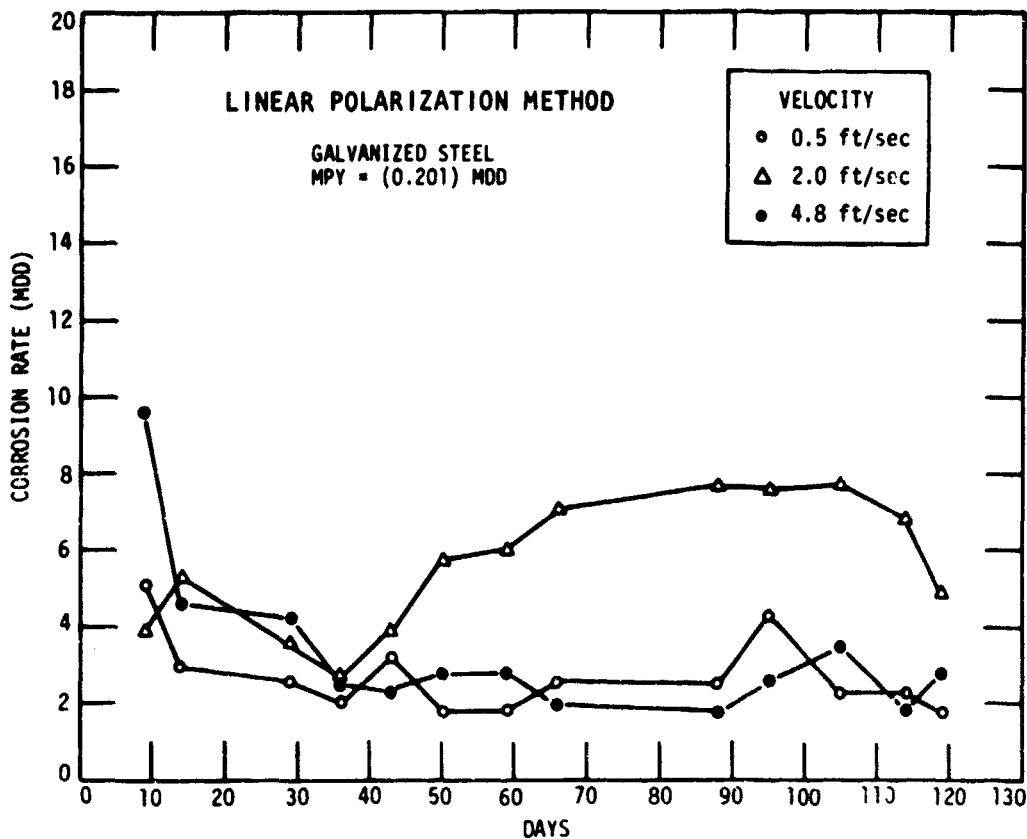

VELOCITY ft/sec	GALVANIZED CORROSION BY WEIGHT LOSS (ASTM, D 2688-C) MDD		
	29 days	90 days	119 days
0.5	30	14	14
2.0	44	28	18
4.8	41	29	26

CORROSION BY WEIGHT LOSS (ASTM, D 2688-C) MDD			
DAYS: 119 VELOCITY: 2.0 ft/sec			
CREVICE			
7.4	35	4.6	55
1/2"Fe	1"Zn	1/2"Fe	2"Zn
GALVANIC			
0.3	62	0.3	50
1"Cu	1"Zn	1"Cu	1"Zn

AVERAGE ANALYSIS (ppm)															
Iron (Fe)	Copper (Cu)	Zinc (Zn)	Calcium (Ca)	Magnesium (Mg)	Hardness (as CaCO <sub>3</sub> )	Phosphate (as Total PO <sub>4</sub> )	Silica (SiO <sub>2</sub> )	Chloride (Cl)	Sulphate (SO <sub>4</sub> )	Nitrate (NO <sub>3</sub> )	Alkalinity (as CaCO <sub>3</sub> )	Disolved Solids	Disolved Oxygen	pH	Temperature (°F)
0.1	.01	.03	16	9	77	0.0	14	363	223	0.0	277	1294	6.8	8.1	132

Figure 50. Corrosion of Galvanized Steel, Site D<sub>1</sub> Run III, Blended Hardness, Added 11 ppm Silica, pH 8.1

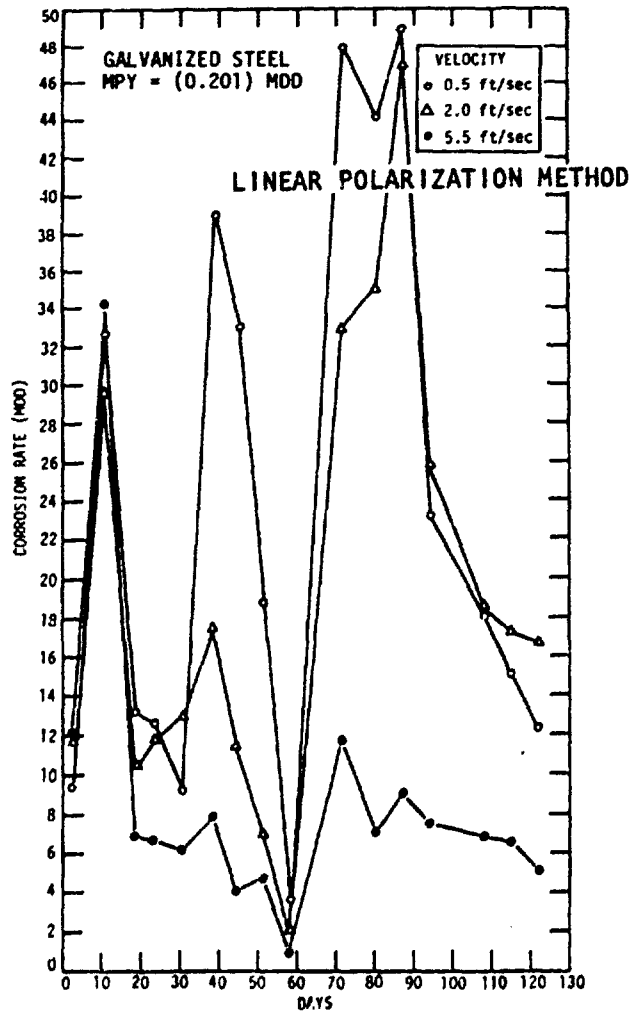

VELOCITY ft/sec	GALVANIZED CORROSION BY WEIGHT LOSS (ASTM, D 2688-C) MDD		
	30 days	92 days	122days
0.5	26	12	33
2.0	31	18	33
5.5	25	18	8

CORROSION BY WEIGHT LOSS (ASTM, D 2688-C) MDD			
DAYS: 122		VELOCITY: 2.0 ft/sec	
CREVICE			
9.1	13	7.1	
1"Zn	1"Zn	2"Zn	
GALVANIC			
0.3	11	0.2	18
1"Cu	1"Zn	1"Cu	1"Zn

AVERAGE ANALYSIS (ppm)												
Iron (Fe)	Copper (Cu)	Zinc (Zn)	Calcium (Ca)	Magnesium (Mg)	Hardness (as CaCO <sub>3</sub> )	Phosphate (as total PO <sub>4</sub> )	Silica (SiO <sub>2</sub> )	Chloride (Cl)	Sulphate (SO <sub>4</sub> )	Nitrate (NO <sub>3</sub> )	Alkalinity (as CaCO <sub>3</sub> )	Dissolved Solids
1.0	.02	.80	12	8	63	0.0	7	434	203	1.1	256	1336
												Dissolved Oxygen
												pH
												Temperature (°F)
												7.9
												181

Figure 51. Corrosion of Galvanized Steel, Site D<sub>2</sub> Run I, Blended Hardness

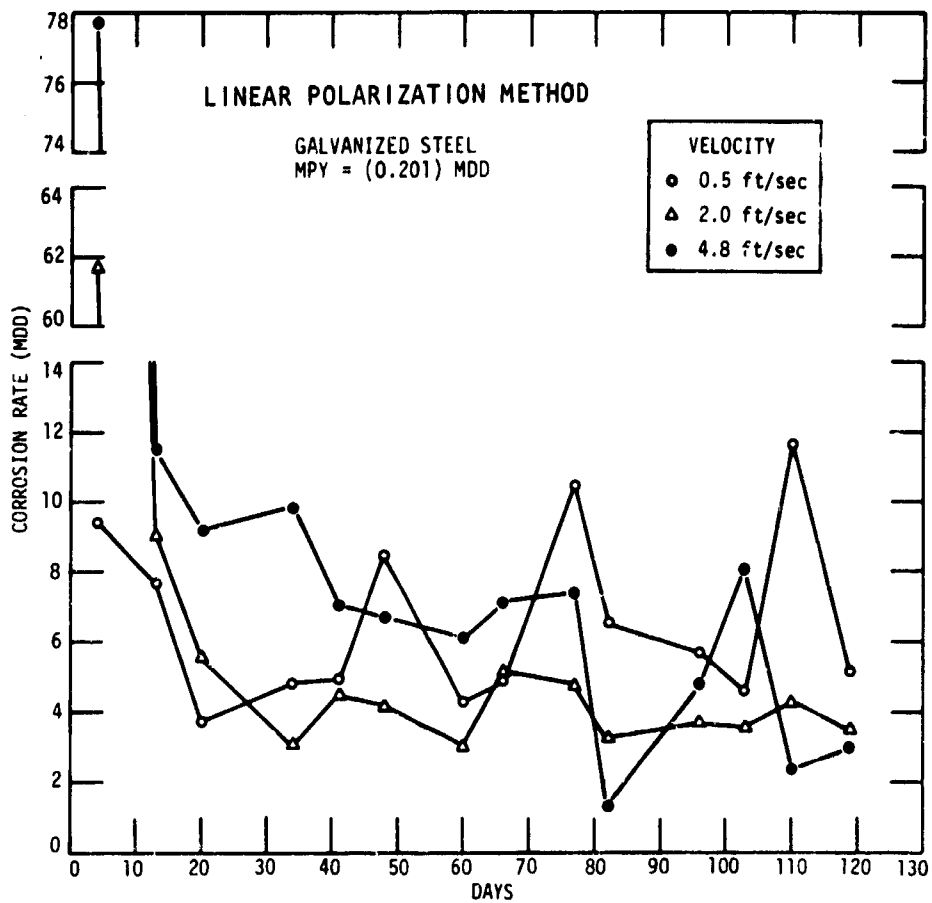

VELOCITY ft/sec	GALVANIZED CORROSION BY WEIGHT LOSS (ASTM, D 2688-C) MDD		
	28 days	91 days	119 days
0.5	46	18	9.5
2.0	52	15	11
4.8	49	17	14

CORROSION BY WEIGHT LOSS (ASTM, D 2688-C) MDD		
DAYS: 119 VELOCITY: 2.0 ft/sec		
CREVICE		
13	14	9.7
1"Zn	1"Zn	2"Zn
GALVANIC		
0.2	16	0.7 23
1"Cu	1"Zn	1"Cu 1"Zn

AVERAGE ANALYSIS (ppm)															
Iron (Fe)	Copper (Cu)	Zinc (Zn)	Calcium (Ca)	Magnesium (Mg)	Hardness (as CaCO <sub>3</sub> )	Phosphate (as Total PO <sub>4</sub> )	Silica (SiO <sub>2</sub> )	Chloride (Cl)	Sulphate (SO <sub>4</sub> )	Nitrate (NO <sub>3</sub> )	Alkalinity (as CaCO <sub>3</sub> )	Dissolved Solids	Dissolved Oxygen	pH	Temperature (°F)
0.2	.01	.60	13	9	70	0.0	23	395	202	0.0	279	1326	3.5	8.1	181

Figure 52. Corrosion of Galvanized Steel, Site D<sub>2</sub> Run II, Blended Hardness, Added 22 ppm Silica, pH 8.1

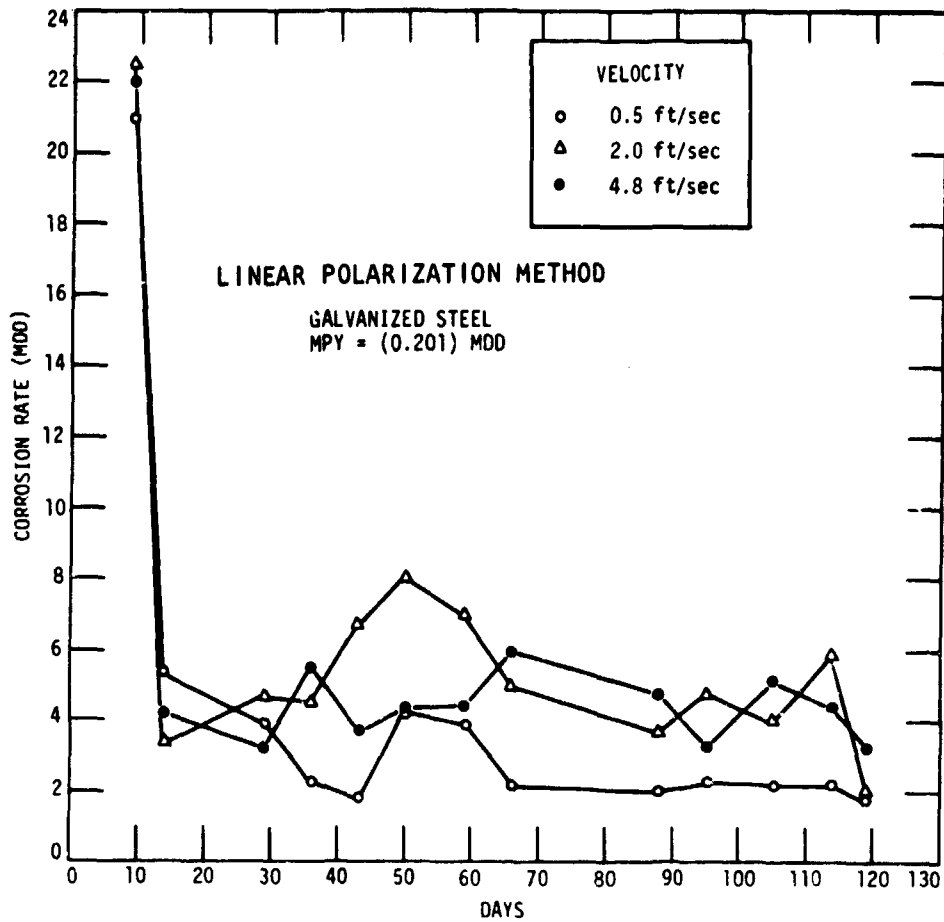

VELOCITY ft/sec	GALVANIZED CORROSION BY WEIGHT LOSS (ASTM, D 2688-C) MDD		
	29 days	90 days	119 days
0.5	37	42	28
2.0	49	48	24
4.8	62	44	29

CORROSION BY WEIGHT LOSS (ASTM, D 2688-C) MDD			
DAYS: 119		VELOCITY: 2.0 ft/sec	
CREVICE			
60	27	57	44
1/2" Fe	1" Zn	1/2" Fe	2" Zn
GALVANIC			
0.5	35	0.2	39
1" Cu	1" Zn	1" Cu	1" Zn

AVERAGE ANALYSIS (ppm)															
Iron (Fe)	Copper (Cu)	Zinc (Zn)	Calcium (Ca)	Magnesium (Mg)	Hardness (as CaCO <sub>3</sub> )	Phosphate (as Total PO <sub>4</sub> )	Silica (SiO <sub>2</sub> )	Chloride (Cl)	Sulphate (SO <sub>4</sub> )	Nitrate (NO <sub>3</sub> )	Alkalinity (as CaCO <sub>3</sub> )	Dissolved Solids	Dissolved Oxygen	pH	Temperature (°F)
0.1	.01	.04	10	8.7	66	0.0	15	403	209	0.0	277	1284	4.4	8.0	81

Figure 53. Corrosion of Galvanized Steel, Site D<sub>2</sub> Run III, Blended Hardness, Added 11 ppm Silica, pH 8.0

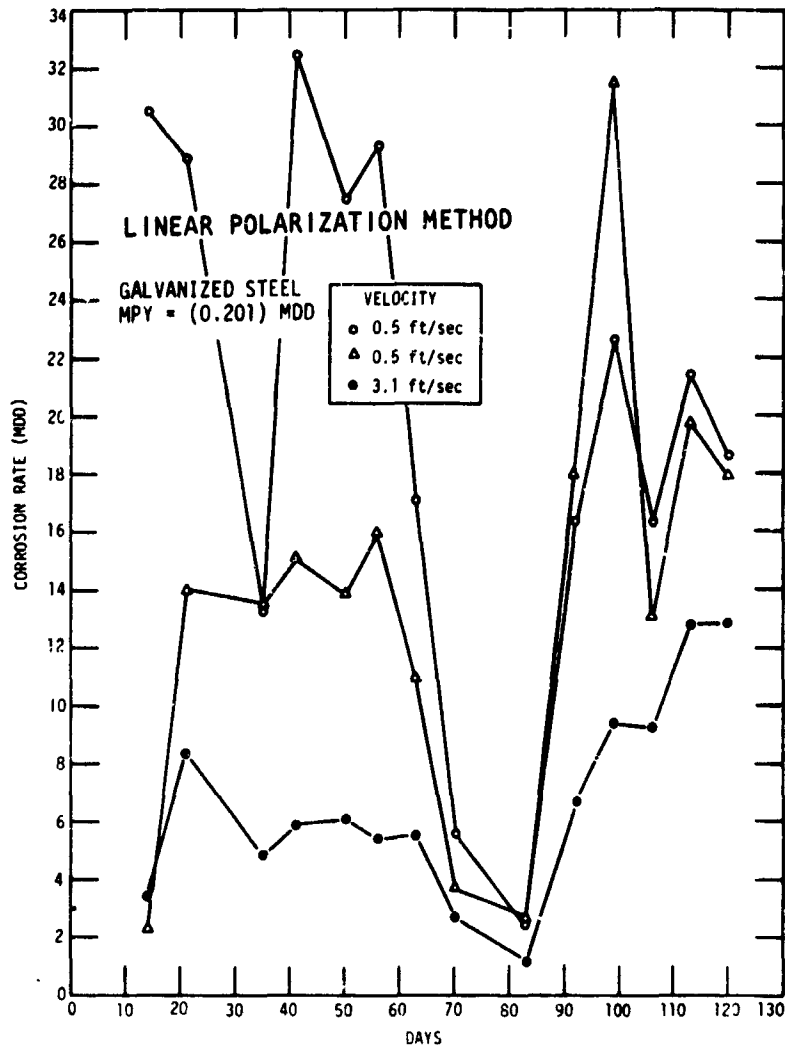

VELOCITY ft/sec	GALVANIZED CORROSION BY WEIGHT LOSS (ASTM, D 2688-C) MDD		
	30 days	90 days	120 days
0.5	55	55	43
0.5	76	64	42
3.1	16	32	12

CORROSION BY WEIGHT LOSS (ASTM, D 2688-C) MDD			
DAYS: 120 VELOCITY: 0.5 ft/sec			
CREVICE			
12	9.4	19	
1"Zn	1"Zn	2"Zn	
GALVANIC			
0.3	75	0.1	52
1"Cu	1"Zn	1"Cu	1"Zn

AVERAGE ANALYSIS (ppm)															
Iron (Fe)	Copper (Cu)	Zinc (Zn)	Calcium (Ca)	Magnesium (Mg)	Hardness (as CaCO <sub>3</sub> )	Phosphate (as PO <sub>4</sub> )	Silica (SiO <sub>2</sub> )	Chloride (Cl)	Sulphate (SO <sub>4</sub> )	Nitrate (NO <sub>3</sub> )	Alkalinity (as CaCO <sub>3</sub> )	Dissolved Solids	Dissolved Oxygen	pH	Temperature (°F)
2.5	40	30	11	6	54	0.1	1	30	1.7	1	236	518	5.7	7.2	144

Figure 54. Corrosion of Galvanized Steel, Site E Run I, Blended Hardness



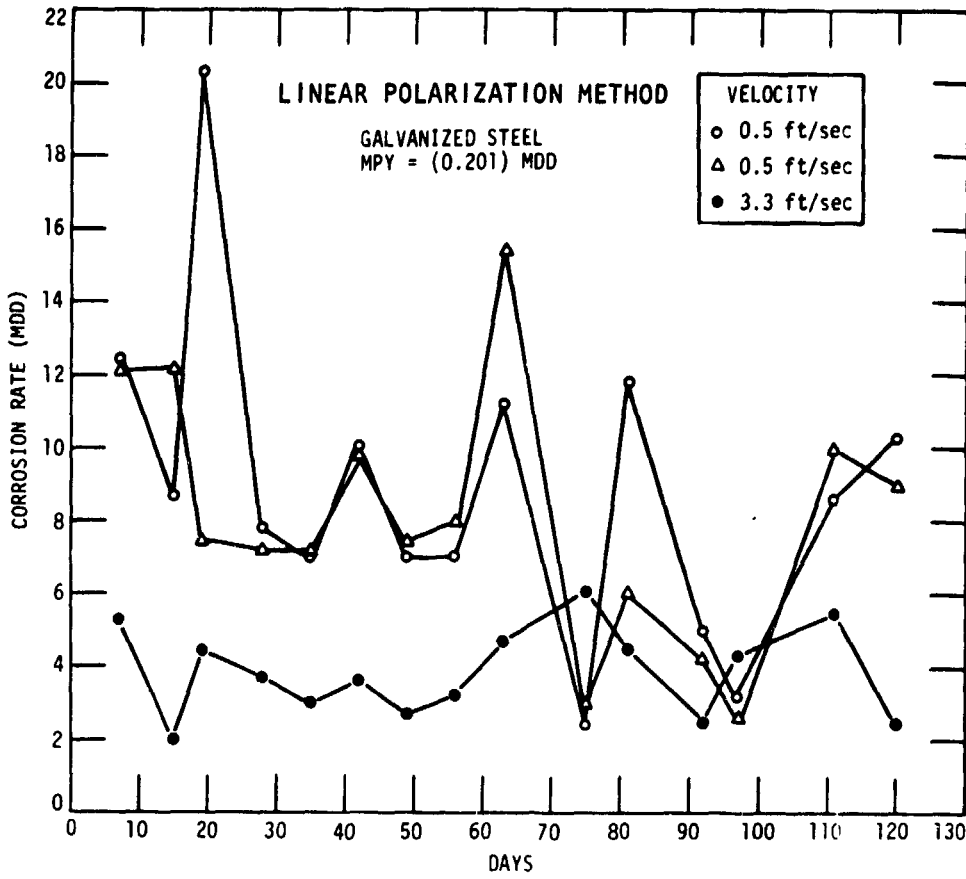

VELOCITY ft/sec	GALVANIZED CORROSION BY WEIGHT LOSS (ASTM, D 2688-C) MDD		
	32 days	88 days	120 days
0.5	81	22	8.6
0.5	72	23	4.7
3.3	38	26	16

CORROSION BY WEIGHT LOSS (ASTM, D 2688-C) MDD			
DAYS: 120 VELOCITY: 0.5 ft/sec			
CREVICE			
25	6.1	??	
1"Zn	1"Zn	2"Zn	
GALVANIC			
1.4	37	0.3	39
1"Cu	1"Zn	1"Cu	1"Zn

AVERAGE ANALYSIS (ppm)															
Iron (Fe)	Copper (Cu)	Zinc (Zn)	Calcium (Ca)	Magnesium (Mg)	Hardness (as CaCO <sub>3</sub> )	Phosphate (as Total PO <sub>4</sub> )	Silica (SiO <sub>2</sub> )	Chloride (Cl)	Sulphate (SO <sub>4</sub> )	Nitrate (NO <sub>3</sub> )	Alkalinity (as CaCO <sub>3</sub> )	Dissolved Solids	Dissolved Oxygen	pH	Temperature (°F)
0.5	.27	.15	12	8	55	0.1	10	25	106	51	195	492	6.8	8.1	146

Figure 55. Corrosion of Galvanized Steel, Site E Run II, Blended Hardness, Added 10 ppm Silica, pH 8.1

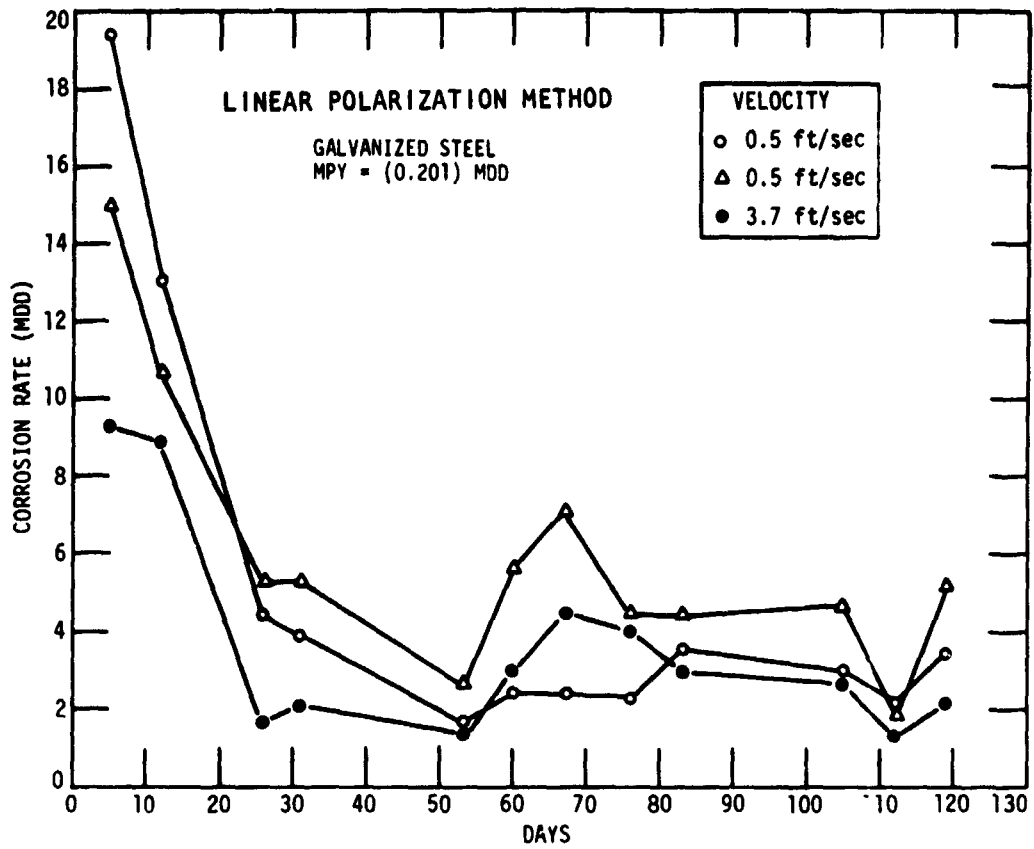

VELOCITY ft/sec	GALVANIZED CORROSION BY WEIGHT LOSS (ASTM, D 2688-C) MDD		
	31 days	88 days	119 days
0.5	93	42	41
0.5	85	41	42
3.7	79	21	51

CORROSION BY WEIGHT LOSS (ASTM, D 2688-C) MDD			
DAYS: 119		VELOCITY: 0.5 ft/sec	
CREVICE			
85	44	70	24
½"Fe	1"Zn	½"Fe	2"Zn
GALVANIC			
11	52	5.4	41
1"Cu	1"Zn	1"Cu	1"Zn

AVERAGE ANALYSIS (ppm)															
Iron (Fe)	Copper (Cu)	Zinc (Zn)	Calcium (Ca)	Magnesium (Mg)	Hardness (as CaCO <sub>3</sub> )	Phosphate (as total PO <sub>4</sub> )	Silica (SiO <sub>2</sub> )	Chloride (Cl)	Sulphate (SO <sub>4</sub> )	Nitrate (NO <sub>3</sub> )	Alkalinity (as CaCO <sub>3</sub> )	Dissolved Solids	Dissolved Oxygen	pH	Temperature (°F)
0.1	.13	.04	15	9	73	0.0	9	26	87	35	235	500	6.2	8.2	153

Figure 56. Corrosion of Galvanized Steel, Site E  
Run III, Added 5 ppm Silica, pH 8.2

Table 1. Pertinent Data on Galvanized Steel Specimens

Site Run	Velocity ft/sec	Temp. °F	Water	H	Added SiO <sub>2</sub>	Added NaOH	pH	Water Analysis		Corrosion Rate (MD/D)			24" Specimen and Deposit Description
								Iron (Fe)	Zinc (Zn)	F <sub>2</sub>	AB	D	
A <sub>1</sub> I	1.3	141	Soft+Cl,SO <sub>2</sub>	4	0	0	7.6	0.5	0.60	20	1.5	19.1	Light brown, fairly continuous
	4.8									11	4.4	7.3	
	5.9												
II	1.3	143	Soft+Cl,SO <sub>2</sub>	3	11	26	8.0	0.4	0.50	24	9.2	27.7	Tan, fairly continuous, little gray area exposed
	4.8									16	1.1	27.5	
	5.9												
III	1.3	137	Blended Hard+Cl,SO <sub>2</sub>	117	11	20	8.1	0.2	0.20	20	0.7	24.9	Brown, continuous, slight heavier scale
	4.8									24	2.9	25.7	
	5.9												
A <sub>2</sub> I	1.3	174	Soft+Cl,SO <sub>2</sub>	5	0	0	7.7	0.6	0.63	8	-4.6	14.4	Red brown, little gray metal exposed
	4.8									7	-5.2	12.2	
	5.9												
II	1.3	168	Soft+Cl,SO <sub>2</sub>	4	20	26	8.3	0.4	0.34	13	5.9	22.4	Tan, not as continuous, considerable galv. exposed
	4.8									16	-1.9	29.2	
	5.9												
III	1.3	167	Blended Hard+Cl,SO <sub>2</sub>	117	25	20	8.2	0.2	0.50	17	4.5	35.0	Brown, continuous, no galv. exposed
	4.8									8	-14.1	39.9	
	5.9												
B <sub>1</sub> I	0.5	142	Hard+Cl,SO <sub>2</sub>	285	18	0	7.8	1.6	0.45	9	3.2	8.0	Off-white, voluminous, non-adhering
	2.0									10	-0.4	13.8	
	5.2									11	-1.1	15.9	
II	0.5	140	Hard	179	0	0	7.7	0.3	0.23	3	1.3	1.0	Tan, fairly continuous, some galv. exposed
	2.0									8	5.5	3.0	
	5.6									10	8.7	2.2	
III	0.5	144	Hard+Cl,SO <sub>2</sub>	140	0	23	8.0	0.5	0.17	19	1.5	19.0	Brown, fairly continuous, thicker, little galv. exposed
	2.0									30	3.3	27.7	
	5.6									24	7.0	19.8	
B <sub>2</sub> I	0.5	180	Hard+Cl,SO <sub>2</sub>	266	18	0	7.8	1.2	0.34	5	-1.8	9.2	Off-white, voluminous, non adhering
	2.0									15	4.5	14.6	
	4.7									12	-2.5	53.7	
II	0.5	178	Hard	170	0	0	7.7	0.3	0.30	1	-2.3	4.4	Brown, fairly continuous, some galv. exposed
	2.0									1	-1.8	2.1	
	4.0									2	-1.1	4.2	
III	0.5	179	Hard+Cl,SO <sub>2</sub>	145	0	23	8.0	0.4	0.16	18	1.3	18.4	Red brown, heavier deposit, some galv. exposed
	2.0									41	3.3	39.9	
	4.7									40	4.2	37.3	
C <sub>1</sub> I	0.5	133	Soft	16	0	0	7.6	0.3	0.25	16	1.4	15.2	Cream-tan, considerable galv. exposed
	2.0									21	2.5	18.6	
	5.0									25	6.6	18.7	
II	0.5	143	Blended Hard	62	9.7	21	8.0	0.0	0.04	4	-6.4	15.0	Tan, continuous, little galv. exposed
	2.0									4	1.6	7.6	
	4.9									18	12.3	15.3	
III	0.5	144	Soft	10	5.9	37	8.1	0.1	0.04	12	0.7	12.4	Brown, continuous, no galv. exposed
	2.0									15	2.9	14.9	
	4.8									20	4.7	16.6	
C <sub>2</sub> I	0.5	126	Soft	19	0	0	7.7	0.1	0.28	5	1.0	5.0	Light brown, thin, continuous, pits starting (?)
	2.0									6	3.8	2.3	
	5.6									16	10.0	7.3	
II	0.5	132	Blended Hard	56	9.7	21	7.8	0.0	0.06	2	-0.2	3.3	Light tan, continuous, thicker, little galv. exposed
	2.0									9	2.3	7.4	
	5.6									11	5.6	6.1	
III	0.5	135	Soft	10	6	17	8.1	0.1	0.04	11	1.9	10.1	Dark tan, thin, continuous, no galv. exposed
	2.0									16	3.1	15.0	
	5.6									16	7.0	10.7	

Table 1. Pertinent Data on Galvanized Steel Specimens (Continued)

Site Run	Velocity ft/sec	Temp. °F	Water	N	Added SiO <sub>2</sub>	Added NaOH	pH	Water Analysis		Corrosion Rate (MDD <sup>a</sup> )			24" Specimen and Deposit Description
								Iron (Fe)	Zinc (Zn)	E <sup>b</sup>	AB	D	
D <sub>1</sub> I	0.5	132	Blended Hard	71	0	0	7.8	1.2	0.50	15	0.6	17.2	Tan, continuous, little galv. exposed
	2.0									-3.0	23.8		
	4.8									-5.3	30.4		
II	0.5	132	Blended Hard	66	22	0	8.1	0.3	0.10	12	1.8	21.4	Dark tan, continuous, no galv. exposed
	2.0									-1.4	25.1		
	5.2									5.7	34.6		
III	0.5	132	Blended Hard	77	11	13	8.1	0.1	0.03	14	-3.8	25.6	Dark tan, continuous, no galv. exposed
	2.0									-5.7	35.1		
	4.8									-3.9	47.4		
D <sub>2</sub> I	0.5	181	Blended Hard	63	0	0	7.8	1.0	0.80	33	-3.9	40.2	Light red brown, slight galv. exposed
	2.0									-6.9	41.6		
	5.5									-7.6	16.7		
II	0.5	181	Blended Hard	70	22	0	8.1	0.2	0.60	10	-1.0	17.9	Red brown, continuous, little galv. exposed
	2.0									-4.3	20.0		
	4.8									-0.6	21.2		
III	0.5	181	Blended Hard	66	11	13	8.0	0.1	0.04	28	-4.2	37.8	Gold brown, continuous, no galv. exposed
	2.0									-4.6	32.5		
	4.8									-4.0	37.2		
E I	0.5	144	Blended Hard	54	0	0	7.7	0.5	0.30	43	-7.5	51.4	Tan, some rust spots that could develop into pits
	0.5									-7.1	50.8		
	3.1									-1.4	14.2		
II	0.5	146	Blended Hard	55	10	26	8.1	0.5	0.15	9	-7.5	20.0	Tan, some rust spots that could develop into pits
	0.5									-6.7	14.7		
	3.3									3.1	14.6		
III	0.5	153	Blended Hard	73	5	18	8.2	0.1	0.04	41	-5.4	59.7	Tan, more deposit and protective than runs I and II
	0.5									-15.7	63.0		
	3.7									-6.8	75.6		

In addition to silicate and caustic soda treatment, 0.2-1.4 ppm of polyphosphate was applied by Chanute Water Plant to all three runs at Site A<sub>1</sub>, A<sub>2</sub>, B<sub>1</sub> and B<sub>2</sub>. Also 5.5 ppm polyphosphate was applied to B<sub>1</sub>, B<sub>2</sub> run I, 2 ppm chestnut tannin to A<sub>2</sub> run III and 3.5 ppm chestnut tannin to C<sub>1</sub>, C<sub>2</sub> run III.

At B<sub>1</sub>, B<sub>2</sub> run I, high hardness caused excessive scale formation in the system. Chanute softener system had become inoperative.

At B<sub>1</sub>, B<sub>2</sub> runs II and III, hardness was higher than desired because of insufficient softener capacity.

Accumulation of corrosion products in flow meters of D<sub>1</sub> runs I-II and D<sub>2</sub> run I made cleaning necessary monthly. D<sub>1</sub> run III and D<sub>2</sub> run II required cleaning every 60 days, while D<sub>2</sub> run III showed no accumulation. Experience at this State Institution has indicated that caustic soda-silicate treatment as applied in run III has reduced maintenance significantly in the past twenty years.

At E runs II and III, the higher temperatures and flow rates than run I undoubtedly increased the corrosion rate.

<sup>a</sup> 120 days, except A<sub>1</sub>, A<sub>2</sub> runs III are 102 days, C<sub>1</sub>, C<sub>2</sub> run II is 90 days and run III is 98 days.

<sup>b</sup> E - After cleaning to metal surface

AB - After cleaning to tight scale surface (Negative value indicates a weight gain on exposure and results from the weight of the scale and corrosion products exceeding the corrosion loss of the specimen.)

D - Total scale and corrosion products

Table 2. Pertinent Data on Copper Corrosion Specimens

Site Run	Velocity ft/sec	Temp. °F	Water	H	Added SiO <sub>2</sub>	Added NaOH	pH	Corrosion Rate			Corrosion Insert Description
								mm <sup>2</sup> Day	mg/ft <sup>2</sup> Day	D	
B <sub>1</sub> I	0.5	142	Hard+Cl,SO <sub>4</sub>	285	18	0	7.8	2.3	1.7	1.9	Dull, sl. fine scratches Red brown, def. fine scratches Red brown, some erosion corrosion
	2.0							3.1	2.7		
	5.2							4.5	4.5		
II	0.5	140	Hard	179	0	0	7.7	8.3	7.6	0.3	Shiny, sl. fine scratches Less shiny, sl. erosion corrosion Less shiny, consid. erosion corrosion
	2.0							16.3	0.2		
	5.6							21.3	0.2		
III	0.5	144	Hard+Cl,SO <sub>4</sub>	140	0.0	23	8.0	6.5	6.0	0.8	Dull, sl. fine scratches Blotchy, some erosion corrosion Shiny, consid. erosion corrosion
	2.0							25.4	0.2		
	5.6							42.1	0.1		
B <sub>2</sub> I	0.5	180	Hard+Cl,SO <sub>4</sub>	266	18	0	7.8	0.9	0.3	1.5	Red brown, sl. fine scratches Red brown, sl. fine scratches Red brown, consid. fine scratches
	2.0							1.9	67.2		
	4.7							1.8	44.1		
II	0.5	178	Hard	170	0	0	7.7	9.1	9.0	0.6	Shiny Less shiny, some erosion corrosion Rough, consid. erosion corrosion
	2.0							28.0	0.3		
	4.0							41.9	0.4		
III	0.5	179	Hard+Cl,SO <sub>4</sub>	145	0	23	8.0	7.1	6.7	0.8	Dull Dull, sl. erosion corrosion Sl. luster, consid. erosion corrosion
	2.0							34.3	0.2		
	4.7							55.5	0.3		
C <sub>1</sub> I	0.5	133	Soft	16	0	0	7.6	8.6	6.9	1.8	Red brown, dull, sl. fine scratches Sl. luster, some erosion corrosion Sl. shiny, consid. erosion corrosion
	2.0							11.0	0.8		
	5.0							27.2	0.5		
II	0.5	143	Blended Hard	62	9.7	21	8.0	8.1	7.9	1.7	Sl. luster, sl. fine scratches Sl. luster, sl. erosion corrosion Sl. tarnished, sl. erosion corrosion
	2.0							13.0	1.4		
	4.9							16.4	1.4		
III	0.5	144	Soft	10	5.9	37	8.1	6.7	6.5	0.7	Shiny, sl. fine scratches Shiny, some erosion corrosion Shiny, consid. erosion corrosion
	2.0							11.0	0.5		
	4.8							13.0	0.5		
C <sub>2</sub> I	0.5	126	Soft	19	0	0	7.7	7.1	5.6	1.7	Dull, sl. fine scratches Dull, some erosion corrosion Dull, consid. erosion corrosion
	2.0							8.6	1.4		
	5.6							11.0	0.6		
II	0.5	132	Blended Hard	56	9.7	21	7.8	7.1	7.1	0.8	Dull, sl. fine scratches Dull, some erosion corrosion Dull, consid. erosion corrosion
	2.0							8.1	0.6		
	5.6							13.2	0.6		
III	0.5	135	Soft	10	5.9	37	8.1	3.7	3.4	10.5	Shiny, sl. fine scratches Shiny, some erosion corrosion Shiny, some erosion corrosion
	2.0							4.2	3.9	15.6	
	5.6							6.8	6.6	10.7	

Table 2. Pertinent Data on Copper Corrosion Specimens  
(Continued)

Site Run	Velocity ft/sec	Temp. °F	Water	H	Added SiO <sub>2</sub>	Added NaOH	pH	Corrosion Rate*			Corrosion Insert Description***
								F**	AB	D	
D <sub>1</sub> I	0.5	132	Blended Hard	71	0	0	7.8	14.0	0.4	14.6	Dark Dark, some erosion corrosion Surface blemishes, some erosion corrosion
	2.0							6.7	9.4		
	4.8							16.0	6.4	10.9	
II	0.5	132	Blended Hard	66	22	0	8.1	3.4	1.1	4.4	Dull, def. fine scratches Dull, def. fine scratches Surface blemishes, def. fine scratches
	2.0							3.7	1.4	4.5	
	5.2							4.0	2.1	4.1	
III	0.5	132	Blended Hard	77	11	13	8.1	3.2	0.3	4.6	Dull, def. fine scratches Dull, sl. erosion corrosion Surface blemishes, sl. erosion corrosion
	2.0							3.3	-4.3	11.6	
	4.8							3.6	-3.8	11.2	
D <sub>2</sub> I	0.5	181	Blended Hard	63	0	0	7.8	10.0	7.8	8.6	Brown Blemished surface Blemished surface, sl. erosion corrosion
	2.0							15.0	11.7	9.0	
	5.5							17.0	13.7	9.2	
II	0.5	181	Blended Hard	70	22	0	8.1	5.1	1.4	6.0	Red brown Dull, sl. erosion corrosion Dull, sl. erosion corrosion
	2.0							9.1	-0.7	10.6	
	4.8							13.0	-1.3	15.9	
III	0.5	181	Blended Hard	66	11	13	8.0	5.6	1.1	8.6	Brown film Brown film, sl. erosion corrosion Brown film, some erosion corrosion
	2.0							10.0	-0.1	10.6	
	4.8							13.0	-1.8	14.6	
E I	0.5	144	Blended Hard	54	0	0	7.7	3.4	2.7	1.2	Sl. luster Dull, sl. fine scratches Dull, sl. fine scratches
	0.5							4.6	3.4	1.7	
	3.1							5.1	3.9	1.7	
II	0.5	146	Blended Hard	55	10	26	8.1	3.5	3.1	0.8	Spotted, sl. fine scratches Discolored, sl. fine scratches Spotted, some erosion corrosion
	0.5							4.1	3.7	0.7	
	3.3							8.1	7.9	0.8	
III	0.5	153	Blended Hard	73	5	18	8.2	10.0	9.5	0.7	Sl. luster, sl. fine scratches Sl. luster, sl. fine scratches Rough, consider. erosion corrosion
	0.5							12.0	11.2	0.9	
	3.7							12.0	11.6	0.7	

Temperature, water analysis data and specimen description is the same for all flows of one run.

In addition to silicate and caustic soda treatment 0.2-1.4 ppm of sodium polyphosphate was applied by Chanute Water Plant to A<sub>1</sub>, A<sub>2</sub>, B<sub>1</sub>, B<sub>2</sub> runs I-III. Also 5.5 ppm polyphosphate was applied to B<sub>1</sub>, B<sub>2</sub> run I, 2 ppm chestnut tannin to A<sub>2</sub> run III and 3.5 ppm chestnut tannin to C<sub>1</sub>, C<sub>2</sub> run III.

\* 120 days, except A<sub>1</sub>, A<sub>2</sub> runs III are 102 days, C<sub>1</sub>, C<sub>2</sub> run II is 90 days and run III is 98 days.

\*\* E - After cleaning to metal surface

AB - After cleaning to tight scale surface (Negative value indicates a weight gain on exposure and results from the weight of the scale and corrosion products exceeding the corrosion loss of the specimen.)

D - Total scale and corrosion products

\*\*\* Fine longitudinal scratches will be designated "slight" (abbrev. sl.) fine scratches and definite (abbreviation def.) fine scratches. Erosion corrosion will be graded slight, some and considerable, indicating increasing seriousness.

Table 3. Pertinent Data on Crevice and Galvanic Corrosion Specimens

Site Run	Temp. °F	Water	Hardness	Added SiO <sub>2</sub>	Added NaOH	pH	Crevice Corrosion Average Galvanized 120 Day*			Galvanic Corrosion Average Copper-Galvanized 120 Day*		
							E**	AB	D	E	AB	D
A <sub>1</sub> I	141	Soft+Cl,SO <sub>4</sub>	4	0	0	7.6	19.4	4.8	15.4	--	--	--
II	143	Soft+Cl,SO <sub>4</sub>	3	11	26	8.0	23.3	6.2	29.2	--	--	--
III	137	Blended Hard+Cl,SO <sub>4</sub>	117	11	20	8.1	42.0	8.2	42.6	--	--	--
A <sub>2</sub> I	174	Soft+Cl,SO <sub>4</sub>	5	0	0	7.7	9.9	0.3	15.2	--	--	--
II	168	Soft+Cl,SO <sub>4</sub>	4	20	26	8.3	24.3	5.7	36.1	--	--	--
III	167	Blended Hard+Cl,SO <sub>4</sub>	117	25	20	8.2	28.8	-3.4	55.7	--	--	--
B <sub>1</sub> I	142	Hard+Cl,SO <sub>4</sub>	285	18	0	7.8	6.0	+0.1	9.7	7.8	-0.3	10.0
II	140	Hard+Cl,SO <sub>4</sub>	179	0	0	7.7	8.9	6.6	2.9	15.4	13.6	2.4
III	144	Hard+Cl,SO <sub>4</sub>	140	0	23	8.0	32.5	9.3	24.6	18.8	7.1	12.6
B <sub>2</sub> I	180	Hard+Cl,SO <sub>4</sub>	266	18	0	7.8	6.7	0.3	37.7	9.8	11.6	35.7
II	178	Hard+Cl,SO <sub>4</sub>	170	0	0	7.7	2.3	0.3	3.9	17.0	14.3	2.8
III	179	Hard+Cl,SO <sub>4</sub>	145	0	23	8.0	22.9	3.0	25.6	30.4	5.3	28.8
C <sub>1</sub> I	133	Soft	16	0	0	7.6	18.5	2.5	16.8	12.6	1.3	11.7
II	143	Blended Hard	62	10	21	8.0	7.5	2.1	6.5	5.8	0.9	5.9
III	144	Soft	10	6	37	8.1	20.8	3.8	19.0	15.9	7.0	9.9
C <sub>2</sub> I	126	Soft	19	0	0	7.7	19.5	2.9	17.0	10.6	1.3	9.4
II	132	Blended Hard	50	10	21	7.8	6.6	0.6	7.1	5.7	2.8	3.8
III	135	Soft	10	6	37	8.1	18.7	4.0	16.2	14.4	4.0	11.5
D <sub>1</sub> I	132	Blended Hard	71	0	0	7.8	10.7	2.7	15.9	34.8	24.5	42.9
II	132	Blended Hard	66	22	0	8.1	21.5	2.2	29.5	51.5	38.3	17.4
III	132	Blended Hard	77	11	13	8.1	41.2	5.5	57.8	28.1	1.0	47.5
D <sub>2</sub> I	181	Blended Hard	63	0	0	7.8	9.6	-2.1	14.5	7.6	-3.3	15.5
II	181	Blended Hard	70	22	0	8.1	16.2	-0.7	20.3	11.0	0.6	17.1
III	181	Blended Hard	66	11	13	8.0	32.3	-1.3	45.1	18.7	-4.0	26.4
E I	144	Blended Hard	54	0	0	7.7	13.3	-2.5	7.0	31.7	7.6	38.0
II	146	Blended Hard	55	10	26	8.1	14.2	1.9	17.5	19.6	7.6	21.3
III	153	Blended Hard	73	5	16	8.2	37.0	-11.8	55.4	27.4	1.4	30.0

\* 120 days, except A<sub>1</sub>,A<sub>2</sub> runs III are 102 days, C<sub>1</sub>,C<sub>2</sub> run II is 90 days and run III is 96 days.

\*\* E - After cleaning to metal surface

AB - After cleaning to tight scale surface (Negative value indicates a weight gain on exposure and results from the weight of the scale and corrosion products exceeding the corrosion loss of the specimen.)

D - Total scale and corrosion products

Table 4. Analyses of Deposits on Galvanized Steel Specimens

Composition	A <sub>1</sub> -I-1	A <sub>1</sub> -II-1	A <sub>1</sub> -III-2	A <sub>2</sub> -III-1	B <sub>1</sub> -I-2	B <sub>1</sub> -III-2	B <sub>2</sub> -I-2	B <sub>2</sub> -II-2	B <sub>2</sub> -III-2	C <sub>1</sub> -I-2
% Loss on ignition	22.5	17.9	23.1	11.3	18.6	20.3	14.3	19.4	21.5	22.9
% Copper oxide (CuO)	0.87	0.28	0.06	0.20	0.16	0.19	0.07	1.40	0.40	0.79
% Iron oxide (Fe <sub>2</sub> O <sub>3</sub> )	1.31	1.88	2.16	3.83	1.39	3.10	1.24		4.17	1.68
% Zinc oxide (ZnO)	74.0	64.2	67.4	21.6	37.5	67.0	14.8	66.5	66.6	71.6
% Calcium oxide (CaO)	0.18	0.06	0.60	0.62	14.6	0.89	36.7	0.70	0.90	0.45
% Magnesium oxide (MgO)	0.13	0.54	0.83	19.30	1.90	0.77	3.13	2.40	1.07	0.34
% Alumina (Al <sub>2</sub> O <sub>3</sub> )	0.9	1.3	0.5	1.5	0.3			1.3	0.7	0.7
% Carbon dioxide (CO <sub>2</sub> )	6.7	5.0	6.1	2.1	4.1	7.2	5.2	5.5	7.5	8.0
% Sulfate (SO <sub>4</sub> )	1.5	0.4	1.2	1.0	0.0			0.0	0.8	1.5
% Phosphorus pentoxide (P <sub>2</sub> O <sub>5</sub> )	0.12	0.16	0.25	0.02	18.8	0.19	14.9	2.43	0.23	0.04
% Silica (SiO <sub>2</sub> )	1.66	14.3	6.07	40.9	1.07	1.62	0.35	1.26	3.05	1.30

Composition	C <sub>1</sub> -I-3	C <sub>2</sub> -III-3	D <sub>1</sub> -I-2	D <sub>1</sub> -II-2	D <sub>1</sub> -III-2	D <sub>2</sub> -I-2	D <sub>2</sub> -II-2	D <sub>2</sub> -III-2	E-I-2	E-II-2	E-III-3
% Loss on ignition	23.8	23.5	25.1	19.5	22.7	20.4	17.7	22.3	22.9	21.3	21.2
% Copper oxide (CuO)	0.92	3.30	0.19	0.07	0.11	0.11	0.27	0.13	2.20	2.40	1.57
% Iron oxide (Fe <sub>2</sub> O <sub>3</sub> )	1.36	2.77	2.05	3.26	1.56	2.11	5.30	5.34	2.48	2.00	2.15
% Zinc oxide (ZnO)	73.8	71.8	65.0	57.4	59.2	64.2	57.9	46.5	67.7	63.3	66.4
% Calcium oxide (CaO)	0.16	0.62	0.46	0.92	4.53	4.52	2.53	7.67	0.36	0.35	0.27
% Magnesium oxide (MgO)	0.19	0.41	0.21	1.33	0.96	0.54	1.57	3.52	0.12	0.73	0.76
% Alumina (Al <sub>2</sub> O <sub>3</sub> )	0.6	1.4	1.2	3.5	2.6	1.6	2.9		0.3	0.8	
% Carbon dioxide (CO <sub>2</sub> )	6.5	8.7	8.8	6.5	9.2	7.3	7.3	9.2	7.2	5.4	7.4
% Sulfate (SO <sub>4</sub> )	1.6	2.3	0.6	0.7	1.4	1.5	0.3	1.2	0.1	0.4	
% Phosphorus pentoxide (P <sub>2</sub> O <sub>5</sub> )	0.01	0.02	0.00	0.00	0.00	0.00	0.00	0.00	0.10	0.03	0.04
% Silica (SiO <sub>2</sub> )	1.14	1.14	1.41	9.88	5.57	4.61	10.4	11.2	0.24	2.24	2.31



Table 5. Summary of Test Conditions and Results

(a) Water Composition, Treatment and Corrosion Test Variables

PPM	A <sub>1</sub> -I-1	A <sub>1</sub> -II-1	A <sub>1</sub> -III-2	A <sub>2</sub> -III-1	B <sub>1</sub> -I-2	B <sub>1</sub> -III-2	B <sub>2</sub> -I-2	B <sub>2</sub> -II-2	B <sub>2</sub> -III-2	C <sub>1</sub> -I-2
Hardness (as CaCO <sub>3</sub> )	4	3	117	117	285	140	266	170	145	16
Alkalinity (as CaCO <sub>3</sub> )	305	357	338	349	348	367	341	342	367	247
Chloride (Cl)	112	131	109	112	102	96	104	4	95	19
Sulfate (SO <sub>4</sub> )	106	111	94	94	105	85	103	1	81	51
Dissolved oxygen	1.8	2.7	1.7	0.8	4.0	5.7	2.1	3.6	2.8	2.0
Carbon dioxide (CO <sub>2</sub> ) (from Alkalinity, pH)	11	5	4	4	8	5	11	13	7	10
Added silica (SiO <sub>2</sub> )	0.0	11	11	25	18	0.0	18	0.0	0.0	0.0
Added caustic soda (NaOH)	0	26	20	20	0	23	0	0	23	0
Added polyphos. (PO <sub>4</sub> )	0	0	0	0	5.5	0	5.5	0	0	0
Added tannin	0	0	0	2.0	0	0	0	0	0	0
Temp.	141	143	137	167	142	144	180	178	178	133
Flow, ft/sec	1.3	1.3	3.7	1.3	2.0	2.0	2.0	2.0	2.0	2.0

(b) Hypothetical Combinations of Deposits  
on Galvanized Steel Specimens

Basic zinc carbonate (4ZnO·CO <sub>2</sub> ·4H <sub>2</sub> O)*	67.3	36.7	59.2	16.1	41.2	67.3	20.1	48.2	70.3	78.3
Zinc oxide (ZnO)*	20.3	0.2	10.8	0.0	7.1	13.3	0.0	31.0	10.9	11.9
Basic zinc pyrosilicate hydrate (Zn <sub>4</sub> (OH) <sub>2</sub> ·Si <sub>2</sub> O <sub>7</sub> ·H <sub>2</sub> O)*	5.2	47.6	16.7	12.4	3.7	5.3	0.0	0.0	5.0	2.6
% Calcium carbonate (CaCO <sub>3</sub> )	0.0	0.0	0.5	1.1	0.0	1.1	30.5	1.0	1.1	0.4
% Hydroxyapatite (Ca <sub>10</sub> (PO <sub>4</sub> ) <sub>6</sub> (OH) <sub>2</sub> )	0.3	0.1	0.6	0.0	26.3	0.5	35.0	1.3	0.5	0.1
% Magnesium phosphate (Mg <sub>3</sub> (PO <sub>4</sub> ) <sub>2</sub> )	0.0	0.2	0.0	0.0	4.1	0.0	0.0	0.9	0.0	0.0
Magnesium silicate (MgSiO <sub>3</sub> )	0.3	1.1	2.1	44.2	0.0	1.9	0.6	2.2	2.7	0.1
% Magnesium hydroxide (Mg(OH) <sub>2</sub> )	0.0	0.0	0.0	0.0	0.0	0.0	4.2	1.7	0.0	0.1
% Copper oxide (CuO)	0.9	0.3	0.1	0.2	0.2	0.2	0.1	1.4	0.4	0.1
% Ferric oxide (Fe <sub>2</sub> O <sub>3</sub> )	1.3	1.9	2.2	3.8	1.4	3.1	1.2	--	4.2	1.7
% Alumina (Al <sub>2</sub> O <sub>3</sub> )	0.9	1.3	0.5	1.5	0.3	--	--	1.3	0.7	0.1
Water, organic, (unaccounted for)	10.6	3.7	10.4	5.6	11.1	7.1	--	11.1	4.7	2.5

\* by x-ray diffraction  
\*\* Silica (SiO<sub>2</sub>): A<sub>2</sub>-III-1 8.4

Table 5. Summary of Test Conditions and Results (Continued)

(a) Water Composition, Treatment and Corrosion Test Variables  
(Continued)

PPM	C <sub>1</sub> -I-3	C <sub>2</sub> -III-3	D <sub>1</sub> -I-2	D <sub>1</sub> -II-2	D <sub>1</sub> -III-2	D <sub>2</sub> -I-2	D <sub>2</sub> -II-2	D <sub>2</sub> -III-2	E-I-2	E-II-2	E-III-3
Hardness (as CaCO <sub>3</sub> )	16	10	71	66	77	63	70	66	54	55	73
Alkalinity (as CaCO <sub>3</sub> )	247	284	264	281	277	256	279	277	236	195	235
Chloride (Cl)	19	20	431	390	363	434	395	403	30	25	26
Sulfate (SO <sub>4</sub> )	51	42	207	201	223	203	202	209	127	106	87
Dissolved oxygen	2.0	0.5	6.3	6.1	6.8	1.8	3.5	4.4	5.7	6.8	6.2
Carbon dioxide (CO <sub>2</sub> ) (from Alkalinity, pH)	10	4	6	3	3	7	4	5	7	2	2
Added silica (SiO <sub>2</sub> )	0.0	6.0	0.0	22	11	0.0	22	11	0.0	10	5.0
Added caustic soda (NaOH)	0	37	0	0	13	0	0	13	0	26	18
Added polyphos. (PO <sub>4</sub> )	0	0	0	0	0	0	0	0	0	0	0
Added tannin	0	3.5	0	0	0	0	0	0	0	0	0
Temp.	133	135	132	132	132	181	181	181	144	146	153
Flow, ft/sec	5.0	5.6	2.0	2.0	2.0	2.0	2.0	2.0	0.5	0.5	3.7

(b) Hypothetical Combinations of Deposits  
on Galvanized Steel Specimens (Continued)

Basic zinc carbonate (4ZnO.CO <sub>2</sub> .4H <sub>2</sub> O)*	64.3	83.3	84.3	58.2	56.2	37.1	53.2	32.1	70.3	52.2	72.3
Zinc oxide (ZnO)*	24.1	8.9	0.0	0.0	6.6	29.5	0.0	6.7	15.7	19.5	0.0
Basic zinc pyrosilicate hydrate (Zn <sub>4</sub> (OH) <sub>2</sub> .Si <sub>2</sub> O <sub>7</sub> .H <sub>2</sub> O)*	2.9	1.9	3.9	18.6	14.4	9.5	24.0	20.6	0.2	5.7	4.1
% Calcium carbonate (CaCO <sub>3</sub> )	0.3	1.0	0.8	1.6	8.1	8.1	4.5	13.7	0.4	0.5	0.4
% Hydroxyapatite (Ca <sub>10</sub> (PO <sub>4</sub> ) <sub>6</sub> (OH) <sub>2</sub> )	0.0	0.1	0.0	0.0	0.0	0.0	0.0	0.0	0.2	0.1	0.1
% Magnesium phosphate (Mg <sub>3</sub> (PO <sub>4</sub> ) <sub>2</sub> )	0.0	0.0	0.0	0.0	0.0	0.0	0.0	0.0	0.0	0.0	0.0
Magnesium silicate (MgSiO <sub>3</sub> )	0.5	1.0	0.5	3.3	2.4	1.3	3.9	8.8	0.3	1.9	1.9
% Magnesium hydroxide (Mg(OH) <sub>2</sub> )	0.0	0.0	0.0	0.0	0.0	0.0	0.0	0.0	0.0	0.0	0.0
% Copper oxide (CuO)	0.9	3.3	0.2	0.1	0.1	0.1	0.3	0.1	2.2	2.4	1.7
% Ferric oxide (Fe <sub>2</sub> O <sub>3</sub> )	1.4	2.8	2.1	3.3	1.6	2.1	5.3	5.3	2.5	2.0	2.2
% Alumina (Al <sub>2</sub> O <sub>3</sub> )	0.6	1.4	1.2	3.5	2.6	1.6	2.9	--	0.3	0.8	--
Water, organic, (unaccounted for)	12.7	9.2	10.3	6.4	7.4	9.2	2.8	7.5	11.3	11.6	7.4

\* by x-ray diffraction

\*\* Silica (SiO<sub>2</sub>): D<sub>1</sub>-I-2 2.5, D<sub>2</sub>-II-2 1.9

## REFERENCES

1. Lane, R. W., and Neff, C. H., "Materials Selection for Piping in Chemically Treated Water Systems," Materials Protection, 8, No. 2, pp. 27-30, 1969.
2. Lehrman, L., and Shuldener, H. L., "Action of Sodium Silicate as a Corrosion Inhibitor in Water Piping," Ind. Eng. Chem., 44, pp. 1765-1769, 1952.
3. Lane, R. W., Ill. State Water Survey investigation, not published.
4. "Standard Methods of Test for Corrosivity of Water in the Absence of Heat Transfer (Weight Loss Methods) D2688-70," ASTM Standards, Part 23, pp. 854-875, 1970.
5. "Standard Methods of Test for Corrosivity of Water in the Absence of Heat Transfer (Electrical Methods) D2776-69T," ASTM Standards, Part 23.
6. Larson, T. E., and Skold, R., "Measurement of the Instantaneous Corrosion Rate," Corrosion, 13, pp. 139t-142t, 1957.
7. Larson, T. E., and King, R. M., "Corrosion by Water at Low Flow Velocity," Jour. AWWA, 46, pp. 1-9, 1954.
8. Fraser, O. B. J., Ackerman, D. E., and Sands, J. M., "Controlled Variables in the Quantitative Study of Submerged Corrosion of Metals," Ind. Eng. Chem., 19, pp. 332, 1927.
9. Dart, F. J., and Foley, P. L., "Preventing Iron Deposition with Sodium Silicate," Jour. AWWA, 62, pp. 663-668, 1970.
10. Champlin, R. L., Corrosion Inhibition of Iron by Silicates, Thesis Harvard University, Jan. 1969.
11. Larson, T. E., "Loss in Pipeline Carrying Capacity Due to Corrosion and Tuberculation," Jour. AWWA, 52, pp. 1263-1270, 1960.
12. Obrecht, M. F., and Quill, L. L., "Tests Show Effects of Water Quality at Various Temperatures, Velocities," Heating Piping and Air Conditioning, pp. 105-113, May 1960.
13. Murray, W. B., "A Corrosion Inhibitor Process for Domestic Water," Jour. AWWA, 62, pp. 659-662, 1970.
14. NACE Task Group T-3D-1 on Instruments for Corrosion Rate Measurement (Issued by NACE Technical Unit Committee T-3D on Instruments for Measuring Corrosion), Modern Electrical Methods for Determining Corrosion Rates, in review 1970.

## BIBLIOGRAPHY

- Britton, S. C., "The Resistance of Galvanized Iron to Corrosion by Domestic Water Supplies," Jour. Soc. Chem. Ind., pp. 19T-22T, Jan. 24, 1936.
- Economic Effects of Mineral Content in Municipal Water Supplies, Office of Saline Water Research and Development, Progress Report No. 26 1967.
- Eliassen, R., Skrinde, R. T., and David, W. B., "Experimental Studies of Corrosion Control By Silicates," New England Water Works Assn., 73, pp. 294-310, 1959.
- Hoxeng, F. B., and Prutton, C. F., "Electrochemical Behavior of Zinc and Steel in Aqueous Media," Part 1, Corrosion, 5, pp. 330-338, 1949; Part 2, Hoxeng, R. B., (only), Corrosion, 6, pp. 308-312, 1950.
- Kenworthy, L., "The Problem of Copper and Galvanized Iron in the Same Water System," Jour. Inst. Metals, 69, pp. 67-90, 1943.
- Larson, T. E., and Skold, R., "Measurement of the Instantaneous Corrosion Rate by Means of Polarization Data," Corrosion, 13, pp. 139t-142t, 1957.
- Rice, J. K., "How to Prevent Corrosion of Galvanized Steel Pipe," Heating, Piping and Air Conditioning, 34(5), pp. 114-116, June 1962.
- "Second Corrosion Study of Pipe Exposed to Domestic Waters," NACE Unit Committee T-7B-2, Materials Protection, 9, pp. 34-37, June 1970.
- "Service Life of Pipe Exposed to Domestic Waters," NACE Unit Committee T4E, Corrosion, 16, pp. 453t-456t, 1960.
- Shuldener, H. L., "Effect of Operating Conditions on Corrosion of Hot Water Piping in Buildings," Corrosion, 10, pp. 85-90, 1954.
- Shuldener, H. L., and Lehrman, L., "Influence of Bicarbonate Ion on Inhibition of Corrosion by Sodium Silicate in a Zinc-Iron System," Jour. AWWA, 49, pp. 1432-1440, 1957.
- Soluble Silicates, Properties and Applications, Philadelphia Quartz Co., Philadelphia, Pa., Bulletin 17-1, 1967.
- Stericker, W., "Protection of Small Water Systems from Corrosion," Ind. Eng. Chem., 37, pp. 716-722, August 1945.
- Stericker, W., "The Application of Soluble Silicates as Corrosion Inhibitors," Proc. 12th Annual Water Conf., Engineers' Society of W. Pa., pp. 109-114, 1951.

Stumm, W., Hüper, H., and Champlin, R. L., "Formation of Poly-  
silicates as Determined by Coagulation Effects," Environ.  
Sci. & Techn., 1, pp. 221-227, March 1967.