

Bangor University

DOCTOR OF PHILOSOPHY

Synthesis of Possible Anti-adhesives for the Treatment of Recurrent Urinary Tract Infections by the Uropathogenic E. coli

Ahmad, Shayma Muhsen

Award date:
2019

Awarding institution:
Bangor University

[Link to publication](#)

General rights

Copyright and moral rights for the publications made accessible in the public portal are retained by the authors and/or other copyright owners and it is a condition of accessing publications that users recognise and abide by the legal requirements associated with these rights.

- Users may download and print one copy of any publication from the public portal for the purpose of private study or research.
- You may not further distribute the material or use it for any profit-making activity or commercial gain
- You may freely distribute the URL identifying the publication in the public portal ?

Take down policy

If you believe that this document breaches copyright please contact us providing details, and we will remove access to the work immediately and investigate your claim.

Download date: 16. May. 2022

Synthesis of Possible Anti-adhesives for the Treatment of Recurrent Urinary Tract Infections by the Uropathogenic *E. coli*



PRIFYSGOL
BANGOR
UNIVERSITY

Shayma Muhsen Ahmad

School of Natural Sciences

Bangor University

A thesis submitted to Bangor University

for the degree of Doctor of Philosophy

© *September 2019*

الى من افنت عمرها لاجلنا
الى الشمعة المتقدة التي تنير ظلمتي

... امي

الى كل من كان سند لي
اخوتي... اخواتي... زوجي
الى قلدة كبدي... اولادي

Declaration and Consent

Details of the Work

I hereby agree to deposit the following item in the digital repository maintained by Bangor University and/or in any other repository authorized for use by Bangor University.

Author Name: Shayma Muhsen Ahmad

Title: Synthesis of Possible Anti-adhesives for the Treatment of Recurrent Urinary Tract Infection by Uropathogenic *E. coli*.

Supervisor/Department: Docent Dr Martina Lahmann/Chemistry

Funding body (if any): Ministry of Higher Education and Scientific Research (MOHESR)

Qualification/Degree obtained: PhD in Chemistry

This item is a product of my own research endeavours and is covered by the agreement below in which the item is referred to as “the Work”. It is identical in content to that deposited in the Library, subject to point 4 below.

Non-exclusive Rights

Rights granted to the digital repository through this agreement are entirely non-exclusive. I am free to publish the Work in its present version or future versions elsewhere.

I agree that Bangor University may electronically store, copy or translate the Work to any approved medium or format for the purpose of future preservation and accessibility. Bangor University is not under any obligation to reproduce or display the Work in the same formats or resolutions in which it was originally deposited.

Bangor University Digital Repository

I understand that work deposited in the digital repository will be accessible to a wide variety of people and institutions, including automated agents and search engines via the World Wide Web.

I understand that once the Work is deposited, the item and its metadata may be incorporated into public access catalogues or services, national databases of electronic theses and dissertations such as the British Library’s EThOS or any service provided by the National Library of Wales.

I understand that the Work may be made available via the National Library of Wales Online Electronic Theses Service under the declared terms and conditions of use (<http://www.llgc.org.uk/index.php?id=4676>). I agree that as part of this service the National Library of Wales may electronically store, copy or convert the Work to any approved medium

or format for the purpose of future preservation and accessibility. The National Library of Wales is not under any obligation to reproduce or display the Work in the same formats or resolutions in which it was originally deposited.

Statement 1:

This work has not previously been accepted in substance for any degree and is not being concurrently submitted in candidature for any degree unless as agreed by the University for approved dual awards.

Signed (candidate)

Date

Statement 2:

This thesis is the result of my own investigations, except where otherwise stated. Where correction services have been used, the extent and nature of the correction is clearly marked in a footnote(s). Other sources are acknowledged by footnotes giving explicit references. A bibliography is appended.

Signed (candidate)

Date

Statement 3:

I hereby give consent for my thesis, if accepted, to be available for photocopying, for inter-library loan and for electronic repositories, and for the title and summary to be made available to outside organisations.

Signed (candidate)

Date

NB: Candidates on whose behalf a bar on access has been approved by the Academic Registry should use the following version of **Statement 3:**

Statement 3 (bar):

I hereby give consent for my thesis, if accepted, to be available for photocopying, for inter-library loans and for electronic repositories after expiry of a bar on access.

Signed (candidate)

Date

Statement 4:

Choose one of the following options

<i>a) I agree to deposit an electronic copy of my thesis (the Work) in the Bangor University (BU) Institutional Digital Repository, the British Library ETHOS system, and/or in any other repository authorized for use by Bangor University and where necessary have gained the required permissions for the use of third party material.</i>	
<i>b) I agree to deposit an electronic copy of my thesis (the Work) in the Bangor University (BU) Institutional Digital Repository, the British Library ETHOS system, and/or in any other repository authorized for use by Bangor University when the approved bar on access has been lifted.</i>	
<i>c) I agree to submit my thesis (the Work) electronically via Bangor University's e-submission system, however I opt-out of the electronic deposit to the Bangor University (BU) Institutional Digital Repository, the British Library ETHOS system, and/or in any other repository authorized for use by Bangor University, due to lack of permissions for use of third party material.</i>	

Options B should only be used if a bar on access has been approved by the University.

In addition to the above I also agree to the following:

1. That I am the author or have the authority of the author(s) to make this agreement and do hereby give Bangor University the right to make available the Work in the way described above.
2. That the electronic copy of the Work deposited in the digital repository and covered by this agreement, is identical in content to the paper copy of the Work deposited in the Bangor University Library, subject to point 4 below.

3. That I have exercised reasonable care to ensure that the Work is original and, to the best of my knowledge, does not breach any laws – including those relating to defamation, libel and copyright.
4. That I have, in instances where the intellectual property of other authors or copyright holders is included in the Work, and where appropriate, gained explicit permission for the inclusion of that material in the Work, and in the electronic form of the Work as accessed through the open access digital repository, or that I have identified and removed that material for which adequate and appropriate permission has not been obtained and which will be inaccessible via the digital repository.
5. That Bangor University does not hold any obligation to take legal action on behalf of the Depositor, or other rights holders, in the event of a breach of intellectual property rights, or any other right, in the material deposited.
6. That I will indemnify and keep indemnified Bangor University and the National Library of Wales from and against any loss, liability, claim or damage, including without limitation any related legal fees and court costs (on a full indemnity bases), related to any breach by myself of any term of this agreement.

Signature:

Date :

Contents

Declaration and Consent	I
Acknowledgements	XII
Abbreviations	XIII
Abstract	XV
Dissemination	XIX
CHAPTER 1 - Carbohydrates	1
1.1 Carbohydrates in Our Life	1
1.2 Carbohydrates – Structure and Conventions	1
1.3 Protecting Groups	5
1.4 Glycosylation	6
1.5 C-Glycosides	8
1.6 Previous Synthesis of C-glycosides as Inhibitors	13
1.7 Participating Groups	15
CHAPTER 2 - <i>Escherichia coli</i> and lectins	18
2.1 <i>Escherichia Coli</i> (<i>E. coli</i>)	18
2.2 The Uropathogenic <i>E.coli</i> (UPEC)	18
2.3 High Affinity Ligands and Inhibition of Bacterial Binding	22
2.4 Inhibitions of The Lectin FimH	23
2.5 Comparison Between C-glycosides and O-glycosides	26
2.6 Multivalent Glycomimetics	27
CHAPTER 3 - Aim of the project	30
CHAPTER 4 - RESULTS AND DISCUSSIONS	32
PART 1 - Synthesis of the pseudo monosaccharide epitopes	32
4.1. Synthesis Design - Overview	32
4.2. Retrosynthetic Pathway Using A CM Reaction	34

4.3 The Synthesis of α -C-L/D-glycosides 92, 11, 103	35
4.3.1 Synthesis of 1'-Deoxy-L-rhamnosyl-1-propene Intermediate 92	36
4.3.2. Synthesis of 1'-Deoxy-D-mannosyl-1-propene Intermediate 11	38
4.3.3. Synthesis of 1'-Deoxy-D-rhamnosyl-1-propene Intermediate 103	39
4.4 Summary	42
4.5 The Synthesis of C-glycosides Using Cross-metathesis	45
4.5.1 Cross-metathesis (CM)	45
4.5.2 The Synthesis of α -C-L/D-glycosides 125, 126, 127 Using CM	49
4.5.3. The Synthesis of Azido L-rhamnose Derivative 130 via CM	53
4.5.4. Synthesis of Azido D-mannose Derivative 133 via CM	56
4.5.5. Synthesis of Azido D-rhamnose Derivative 136 via CM	57
4.6 Wittig Olefination	61
4.6.1. Synthesis of Aldehyde Compounds 141, 137, 143 by Ozonolysis	62
4.6.2. Synthesis of Phosphonium Salts	64
4.6.3 Synthesis of 138, 142, 144 Using Wittig Coupling Reaction	65
4.6.4 Synthesis of The Compounds 130, 133, 136	69
4.7 Summary	70
PART 2 - The synthesis of bifunctional linkers and attempted conjugations	72
4.8 The Synthesis of Bifunctional Linkers and Attempted Conjugation of The Pseudo Sugars to Alginate	72
4.9 Synthesis of The Bifunctional Linker 152	72
4.9.1 First Route for Synthesis of Linker 152 (Staudinger Reactions)	73
4.9.2 Second Route for Synthesis of The Bifunctional Linker 152	73
4.10 Summary	78
4.11 Hydrogels	80
4.11.1 Alginate - General	80
4.11.2 Attempted Synthesis of A Hydrogel	81

4.12 Summary	83
4.13 Gold Glyconanoparticles	84
4.13.1 Synthetic Pathway of Gold Nanoparticles	84
4.14 Synthesis of The Thio-Spacer.....	85
4.15 Click Chemistry Including Copper Mediated Click Reactions (CuAAC)	90
4.15.1 Synthesis of 1,2,3-Triazole Compounds.....	91
4.16 Summary	94
CHAPTER 5 - Conclusions and Future Work.....	95
5.1 Conclusions	95
5.2 Future Work	97
5.2.1 Synthesis of Multivalent of C-glycosides via Nanoparticles.....	97
5.3 Suggestions.....	98
5.3.1 Synthesis of Wittig Salt With A Linker of Aldehyde.....	98
CHAPTER 6 - EXPERIMENTAL	100
6.1 General Procedures	100
6.2 Experimentals for Individual Compounds	101
6.2.1 Methyl L-rhamnopyranoside 90	101
6.2.2 Methyl 2,3,4-Tri- <i>O</i> -benzyl-L-rhamnopyranoside 91	101
6.2.3 1,2,3,4-Tetra- <i>O</i> -acetyl-L-rhamnopyranose 93	102
6.2.4 3-(1'-Deoxy-2',3',4'-tri- <i>O</i> -acetyl-L-rhamnopyranose-1'-yl)-1-propene 94	103
6.2.5 3-(1'-Deoxy-L-rhamnopyranose-1'-yl)-1-propene 95	104
6.2.6 3-(1'-Deoxy-2',3',4'-tri- <i>O</i> -benzyl- α -L-rhamnopyranose-1'-yl)-1-propene 92	105
6.2.7 2-(1'-Deoxy-2',3',4'-tri- <i>O</i> -benzyl- α -L-rhamnopyranose-1'-yl)ethanal 141	106
6.2.8 6-((<i>tert</i> -Butyldiphenylsilyl)oxy)hexan-1-ol 81	107
6.2.9 6-((<i>tert</i> -Butyldiphenylsilyl)oxy)1-iodo-hexane 82	108
6.2.10 (6-((<i>tert</i> -Butyldiphenylsilyl)oxy)hexyl)triphenylphosphonium iodide 83	109
6.2.11 6-Bromohexan-1-ol 145	110

6.2.12 6-((<i>tert</i> -Butyldiphenylsilyl)oxy)-1-bromohexane 146	110
6.2.13 (6((<i>tert</i> -Butyldiphenylsilyl)oxy)hexyl)triphenylphosphoniumbromide 147	111
6.2.14 8-(2',3',4'-Tri- <i>O</i> -benzyl-1'-deoxy- α -L-rhamnopyranos-1'yl)-1-(<i>tert</i> - butyldiphenylsilyloxy)oct-6-ene 142	112
6.2.15 8-(2',3',4'-Tri- <i>O</i> -benzyl-1'-deoxy- α -L-rhamnopyranos-1'yl)-oct-6-en-1-ol 126	113
6.2.16 8-(2',3',4'-Tri- <i>O</i> -benzyl-1'-deoxy- α -L-rhamnopyranos-1'yl)-oct-6-en-1-yl tosylate 128	114
6.2.17 8-(1'-Deoxy- α -L-rhamnopyranos-1'yl)oct-1-yl tosylate 129	115
6.2.18 8-(1'-Deoxy- α -L-rhamnopyranos-1'yl)-oct-1-azide 130	115
6.2.19 1,2,3,4,6-Penta- <i>O</i> -acetyl- α,β -D-mannopyranose 27	116
6.2.20 3-(1'-Deoxy-2',3',4',6'-Tetra- <i>O</i> -acetyl-D-mannopyranose-1'-yl)-1-propene 96 ..	117
6.2.21 3-(1'-Deoxy-D-mannopyranos-1'-yl)-1-propene 97	118
6.2.22 3-(1'-Deoxy-2',3',4',6'-tetra- <i>O</i> -benzyl- α -D-mannopyranos-1'-yl)-1-propene 11	119
6.2.23 2',3',4',6'-Tetra- <i>O</i> -benzyl-2'- α -D-mannopyranosylethanal 137	120
6.2.24 8-(2',3',4',6'-Tetra- <i>O</i> -benzyl-1'-deoxy- α -D-mannopyranos-1'yl)-oct-6-en-1- (<i>tert</i> -butyldiphenylsilyl)oxy 138	121
6.2.25 8-(2',3',4',6'-Tetra- <i>O</i> -benzyl-1'-deoxy- α -D-mannopyranos-1'yl)-oct-6-en-1-ol 125	122
6.2.26 8-(2',3',4',6'-Tetra- <i>O</i> -benzyl-1'-deoxy- α -D-mannopyranos-1'yl)-oct-6-en-1-(4- Toluenesulfonyloxy) 131	123
6.2.27 8-(1'-Deoxy- α -D-mannopyranos-1'yl)-oct-1-(4-Toluenesulfonyloxy) 132	124
6.2.28 8-(1'-Deoxy- α -D-mannopyranos-1'yl)-oct-1-azide 133	124
6.2.29 Methyl 6- <i>O</i> - <i>tert</i> -Butyldiphenylsilyl- α -D-mannopyranoside 98	125
6.2.30 Methyl 2,3,4-Tri- <i>O</i> -benzyl-6- <i>O</i> - <i>tert</i> -butyldiphenylsilyl- α -D-manno-pyranoside 99	126
6.2.31 Methyl 2,3,4-Tri- <i>O</i> -benzyl- α -D-mannoside 100	127

6.2.32 Methyl 2,3,4-Tri- <i>O</i> -benzyl-6- <i>O</i> -tosyl- α -D-mannopyranose 101	128
6.2.33 Methyl 2,3,4-Tri- <i>O</i> -benzyl- α -D-rhamnopyranoside 102	129
6.2.34 3-(1'-Deoxy-2',3',4'-tri- <i>O</i> -benzyl- α -D-rhamnopyranose-1'-yl)-1-propene 103 ...	130
6.2.35 Methyl 6- <i>O</i> -tosyl- α -D-mannoside 106	131
6.2.36 Methyl- α -D-rhamnopyranose 107	131
6.2.37 2-(1'-Deoxy-2',3',4'-tri- <i>O</i> -benzyl- α -D-rhamnopyranose-1'-yl)ethanal 143	132
6.2.38 8-(2',3',4'-Tri- <i>O</i> -benzyl-1'-deoxy- α -D-rhamnopyranos-1'yl)-oct-6-en-1-(<i>tert</i> - butyldiphenylsilyloxy) 144	133
6.2.39 8-(2',3',4'-Tri- <i>O</i> -benzyl-1'-deoxy- α -D-rhamnopyranos-1'yl)-oct-6-en-1-ol 127	134
6.2.40 8-(2',3',4'-Tri- <i>O</i> -benzyl-1'-deoxy- α -D-rhamnopyranos-1'yl)-oct-6-en-1-(4-tosyl) 134	135
6.2.41 8-(1'-Deoxy- α -D-rhamnopyranos-1'yl)-oct-1-(4-tosyl) 135	136
6.2.42 8-(1'-Deoxy- α -L-rhamnopyranos-1'yl)-oct-1-azide 136	137
6.2.43 8'-((1,2,3-Triazol)-4-yl)methoxyethoxyethanthioacetate)-1- <i>C</i> - α -L- rhamnopyranose 173	138
6.2.44 8'-((1,2,3-Triazol)-4-yl)methoxyethoxyethanthioacetate)-1- <i>C</i> - α -D- mannopyranose 174	139
6.2.45 8'-((1,2,3-Triazol)-4-yl)methoxyethoxyethanthioacetate)-1- <i>C</i> - α -D- rhamnopyranose 175	140
6.3 Experimentals for Individual Compounds of CM.....	141
6.3.1 8-(2',3',4'-Tri- <i>O</i> -benzyl-1'-deoxy- α -L-rhamnopyranos-1'yl)-oct-6-en-1-ol 126- CM	141
6.3.2 8-(2',3',4'-Tri- <i>O</i> -benzyl-1'-deoxy- α -L-rhamnopyranos-1'yl)-oct-6-en-1-(4- toluenesulfonyloxy) 128-CM	141
6.3.3 8-(1'-Deoxy- α -L-rhamnopyranos-1'yl)-oct-1-(4-toluenesulfonyloxy) 129-CM ..	142
6.3.4 8-(1'-Deoxy- α -L-rhamnopyranos-1'yl)-oct-1-azide 130-CM	143

6.3.5 8-(2',3',4',6'-Tetra- <i>O</i> -benzyl-1'-deoxy- α -D-mannopyranos-1'yl)-oct-6-en-1-ol 125-CM	143
6.3.6 8-(2',3',4',6'-Tetra- <i>O</i> -benzyl-1'-deoxy- α -D-mannopyranos-1'yl)-oct-6-en-1-(4- toluenesulfonyloxy) 131-CM	144
6.3.7 8-(1'-Deoxy- α -D-mannopyranos-1'yl)-oct-1-(4-toluenesulfonyloxy) 132-CM ..	145
6.3.8 8-(1'-Deoxy- α -D-mannopyranos-1'yl)-oct-1-azide 133-CM	145
6.3.9 8-(2',3',4'-Tri- <i>O</i> -benzyl-1'-deoxy- α -D-rhamnopyranos-1'yl)-oct-6-en-1-ol 127- CM	146
6.3.10 8-(2',3',4'-Tri- <i>O</i> -benzyl-1'-deoxy- α -D-rhamnopyranos-1'yl)-oct-6-en-1-(4- toluenesulfonyloxy) 134-CM	147
6.3.11 8-(1'-Deoxy- α -D-rhamnopyranos-1'yl)-oct-1-(4-toluenesulfonyloxy) 135-CM	147
6.3.12 8-(1'-deoxy- α -D-rhamnopyranos-1'yl)-oct-1-azide 136-CM	148
6.4 Synthesis of The Bifunctional Spacer	149
6.4.1 2-(2-4-Toluenesulfonyloxy ethoxy)ethan-1-ol 149	149
6.4.2 2-(2-Azido ethoxy)ethan-1-ol 150	149
6.4.3 3-(2-(2-Azidoethoxy)ethoxy)prop-1-yne 151	150
6.4.4 2-(2-Prop-2-ynyloxy)ethoxy)ethan-1-ol 153	151
6.4.5 3-(2-4-Toluenesulfonyloxy ethoxy)prop-1-yne 154	151
6.4.6 3-(2-Phthalimideoxyethoxy)prop-1-yne 155	152
6.4.7 2-(2-(Prop-2-ynyloxy)ethoxy)ethanamine 152	153
6.4.8 2-(2-(Prop-2-ynyloxy)ethoxy)ethan thioacetate 171	154
CHAPTER 7 Appendices	155
7.1 Attempted Failed Coupling Reactions of Alginate With The Amino-Linker.....	155
7.1.1 Attempt to Synthesise Scaffold of Alginate With 2-(2-(Prop-2- ynyloxy)ethoxy)ethanamine	155
7.1.2 Attempt to Synthesise Scaffold of Alginate With Propargyl Amine.....	156
7.2. Attempt to Synthesise of Thio-Linker With Amide Bond	156

7.2.1 Testing The Dithiodiglycolic Acid With Benzyl Amine.....	156
7.3 Attempted The Coupling of Dithiodiglycolic Acid With Acetylated of 8-(1'-Deoxy- α -L-rhamnopyranos-1'yl)-oct-1-amine	158
7.4 Testing The Coupling of Dithiodiglycolic Acid With Propargyl Amine.....	160
7.5 Testing of Formation of Amide Bond With 2-aminoethane-1-thiol	160
7.6 Testing of The Thiol-ene Reaction.....	161
7.7 Testing of The Click Reaction	163
References	166

Acknowledgements

I would like to acknowledge my gratitude to the Ministry of Higher Education and Scientific Research (MOHESR) in Iraq for providing me with a Scholarship to study for a PhD in Chemistry for the academic years 2015–2019, which fully covered my tuition fees and my living expenses in UK. I would also like to thank the University of Al-Nahrain for their support.

I would like to express my special thanks to my well admirable supervisor, Dr Martina Lahmann for her guidance, support and patience throughout my time in completing my project.

I'm highly indebted to Dr Marc Bouillon for his guidance and help throughout my project. I would also like to extend my gratitude to Dr Juma'a R. Al-Dulayymi, Anna Cervi, Dr Deiniol Pritchard, and all the other members in the 10th floor to for their help and assistance.

I am thankful to my colleagues Mohammed Al-Mashhadani, Zahraa Al-Taie, and all the PhD students on the 5th floor for helping me to use the freeze dryer, pH meter and the Vortex shaker providing me with all facilities that were required.

My thanks and appreciation also go to the Staff members of the School of Natural Sciences for their invaluable help in the running of my NMR and Mass samples.

Many thanks also to my family which is the best thing in my life. Without you the world would be so dark.

Abbreviations

Ac	Acetyl
AIBN	Azobisisobutyronitrile
Asn	Asparagine
AuNPs	Gold nanoparticles
9-BBN	9-Borabicyclo[3.3.1]nonane
BF ₃ ·OEt ₂	Boron trifluoride diethyl etherate
Bn	Benzyl
CD	Crohn's disease
CDI	Carbonyldiimidazole
CM	Cross-metathesis
COSY	Correlation spectroscopy
δ	Chemical shift
d	Doublet
dd	Double doublet
DCC	<i>N,N'</i> -Dicyclohexylcarbodiimide
DCM	Dichloromethane
DE	Diethyl ether
DEPT	Distortionless Enhancement by Polarization Transfer
DEPTQ	DEPT including quaternary carbons
DIBAL	Diisobutylaluminium hydride
DIPEA	<i>N,N</i> -Diisopropylethylamine
DMAP	4-Dimethylaminopyridine
DMF	<i>N,N'</i> -Dimethylformamide
DMPU	<i>N,N'</i> -Dimethylpropylene urea
EA	Ethyl acetate
EDC	1-Ethyl-3-(3-dimethylaminopropyl)carbodiimide
<i>E. coli</i>	<i>Escherichia coli</i>
eq	Equivalent
ESI	Electrospray Ionisation
GlcNAc	<i>N</i> -Acetylglucosamine
Grubbs 1 st	Grubbs first generation catalyst
Grubbs 2 nd	Grubbs second generation catalyst
GNPs	Glyco nanoparticles
GAuNPs	Glycogold nanoparticles
HATU	1-[Bis(dimethylamino)methylene]-1 <i>H</i> -1,2,3-triazolo-[4,5- <i>b</i>]pyridinium 3-oxid hexafluorophosphate

HOBt.....	Hydroxybenzotriazole
HRMS	High resolution mass spectrometry
HSQC.....	Heteronuclear single-quantum correlation spectroscopy
Hex.....	Hexane
Ile	Isoleucine
IR.....	Infrared
ITC	Isothermal titration
<i>J</i>	Coupling constant
<i>K</i>	Equilibrium constant
<i>K</i> _d	Dissociation constant
LAH	Lithium aluminium hydride
LiHMDS	Lithium bis(trimethylsilyl)amide
<i>m</i>	Multiplet
Man.	Mannose
Me	Methyl
NHS.....	<i>N</i> -hydroxysuccinimide
NMR	Nuclear magnetic resonance
o/n	Overnight
Pd/C.....	Palladium on charcoal
PE.....	Petroleum ether
<i>R</i> _f	Ratio of fronts
Ph	Phenyl
rt.....	Room temperature
Ser	Serine
SPR	Surface plasmon resonance
<i>t</i>	Triplet
TBAF	Tetra- <i>n</i> -butylammonium fluoride
TBDPSCl	<i>tert</i> -Butyldiphenylsilylchloride
THF	Tetrahydrofuran
TLC	Thin layer chromatography
TMS	Trimethylsilane
TMSOTf.....	Trimethylsilyl trifluoromethanesulfonate
Tol.....	Toluene
TPAP.....	Tetrapropylammonium perruthenate
TsCl.....	4-Toluenesulfonyl chloride
Tyr.....	Tyrosine
UV.....	Ultraviolet
UPEC	Uropathogenic <i>Escherichia coli</i>
UPIa	Uroplakin Ia
UTIs	Urinary tract infections

Abstract

Carbohydrates play a crucial role in biological life. The synthesis of carbohydrate molecules in this work are for studying biological processes.

Uropathogenic *E. coli* (UPEC) is the major cause of urinary tract infections (UTIs). The majority of UTIs begin in the bladder, which is the main target organ, causing cystitis or acute inflammation (pyelonephritis) in the upper part of the urinary tract as a result of the bacterial colonisation. This colonisation can be initiated via the FimH adhesin located at the tip of type 1 pili. FimH can recognise a wide range of glycoprotein mannose structures. This knowledge can support the synthesis and design of receptor mimetics. A range of inhibitors have been synthesised to block or inhibit the FimH receptor interactions.

The *C*-monosaccharide derivatives described in this work (**Figure A**) have been synthesized as probes and as novel therapeutics for investigating the binding site of the uropathogenic *Escherichia coli* (UPEC) in urine, the major cause of urinary tract infections (UTIs).

In more detail, this work describes the synthesis of FimH anti-adhesives which are α -*C*-(8-azidoethyl)-mannoside, α -*D*-*C*-(8-azidoethyl)-rhamnoside and α -*L*-*C*-(8-azidoethyl)-rhamnoside. Compound α -*C*-(8-azidoethyl)-mannoside is an analogue of the terminal part of uroplakin 1a (UP1a), a protein found on the superficial epithelial umbrella cells of the bladder. While the other compounds **II** and **III** are intended as reference compounds (non-binder **II** and weak binder **III**).

The syntheses start all with the introduction of the pseudo anomeric *C*-allyl group using known procedures from an appropriate monosaccharide as intermediate. However, a chain of 8 atoms has been proposed to be effective for good binding to FimH. Therefore, the key step for the preparation of the target compounds is connecting the remaining linker atoms including an additional functional group that will allow for further conjugation, e.g. in order to achieve multivalent analogous, to the 3-(1'-deoxyglycopyranos-1'-yl)-1-propenes. Both the Wittig reaction and the cross metathesis (CM) were evaluated for this chain extension step and the Wittig reaction was found to superior over the CM which gave inseparable side products and thus impure target compounds. The final compounds **I**, **II**, and **III** were characterized by ¹H-NMR and ¹³C spectroscopy. In order to achieve multivalent presentation of the ligands and additional linker, 2-(2-(prop-2-ynyloxy)ethoxy)ethanthioacetate **171**, was attached via click chemistry to

these compound. *In situ* removal of the thioacetate enables conjugation to gold nanoparticles and thus multivalent conjugates.

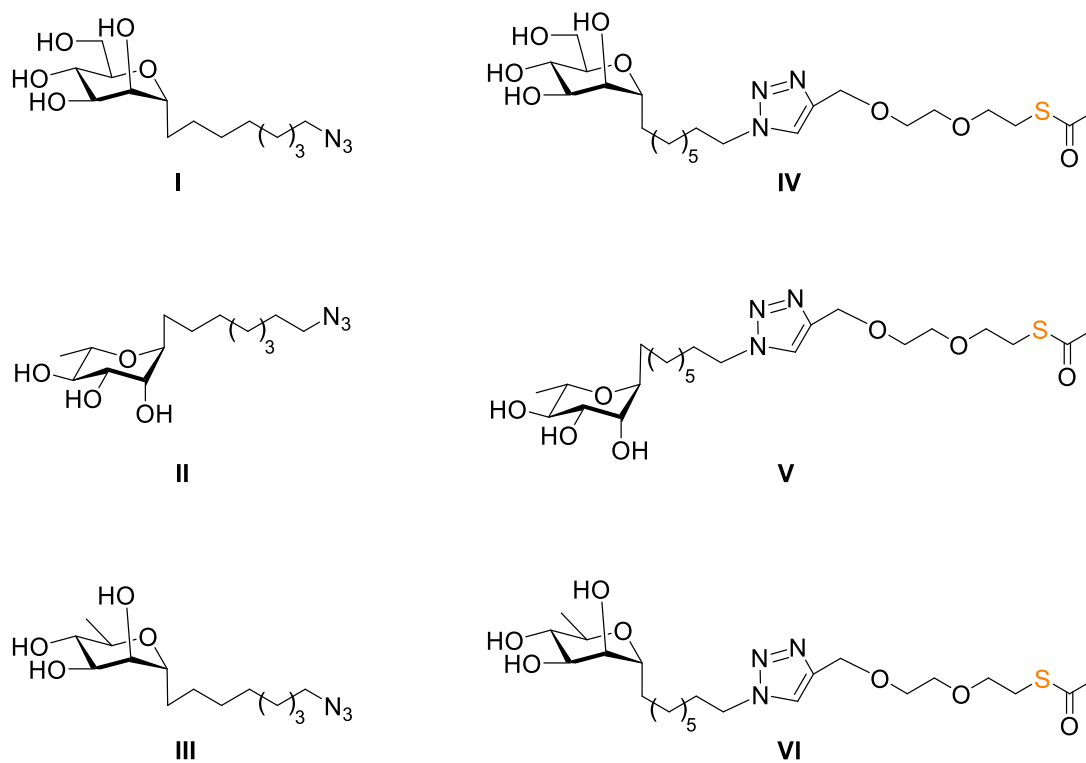

Figure A: Structures of the primary target compounds **I**, **II** and **III** and their derivatives **IV**, **V** and **VI** for gold nanoparticles binding to achieve multivalency.

نبذة مختصره

تلعب الكربوهيدرات دورًا مهمًا في الحياة البيولوجية. تخليق الجزيئات الكربوهيدراتية في هذا العمل هي لغرض دراسة العمليات البيولوجية.

البكتريا القولونية المسببه للمرض (UPEC) هي السبب الرئيسي لالتهابات المسالك البولية في المثانة (UTIs). وهي العضو الرئيسي المستهدف مسببة التهاب المثانة (cystitis) أو الالتهابات الحادة (التهاب الحويضة والكلية pyelonephritis) في الجزء العلوي من الجهاز البولي نتيجة الى الاستعمار الجرثومي. هذا الاستعمار يمكن ان يبدأ عن طريق اللواصق (FimH) الموجوده على قمه نوع بيلي 1 (pili 1). هذه اللواصق يمكن ان تتعرف على مجموعته واسعه من تراكيب المانوز البروتينيه السكريه. نتيجة الى هذه المعرفه يمكن تخليق وتصميم مستقبلات مقلده. عدد من المثبطات قد تم تخليقها لمنع او تثبيط تفاعلات مستقبلات Fim H.

المشتقات السكرية الاحادية المخلفة بذرة الكربون على المركز الانوميري قد وصفت في هذا المجال (شكل A) كمجسات وعلاجات جديده لغرض بحث ودراسه مواقع الارتباط الخاصه بالبكتريا القولونية المسببه للمرض في الاضرار والسبب الرئيسي لالتهابات المسالك البولية (UTIs).

مزيده من التفاصيل هذا العمل يصف تخليق مركبات مضاده الالتصاق لل FimH والتي هي

α -D-C-(8-azidooctyl)-mannoside, α -D-C-(8-azidooctyl)-rhamnoside and α -L-C-(8-uroplakin α -C-(8-azidooctyl)-mannoside المركب هو نظير للجزء النهائي ل UP1a) وهو بروتين موجود على خلايا المظله الظهاريه السطحيه للمثانه. بينما المركبات الاخرى II و III هي مخصصه كمركبات سلبيه (II لا يرتبط و III ضعيف الارتباط).

تخليق المركبات بدأ بتقديم مجموعه الاليل-كربون الشاده بواسطة طرائق عمل معروفه باستخدام سكريات احاديه مناسبه كمركبات وسطيه. ومع ذلك، فقد تم اقتراح سلسله من 8 ذرات كربون لتكون فعالة لربط جيد ل FimH. لذلك، تتمثل الخطوة الأساسية لتخليق المركبات المستهدفة في توصيل ذرات السلسله المتبقية و المتضمنه مجموعه وظيفية إضافية تسمح بمزيد من الارتباط، على سبيل المثال من أجل تحقيق النظائر المتعددة الارتباط الى مركبات 3-(1'-deoxyglycopyranos-1'-yl)-1-propenes

كلا التفاعلين Wittig reaction و Cross metathesis (CM) استخدمت لغرض تمديد السلسله وقد وجد بان Wittig reaction كان متفوقا على (CM) والذي اعطى نواتج جانبيه غير منفصله و بالتالي لوثت المركبات المستهدفه. المركبات النهائيه I, II, III تم تشخيصها بواسطة طيف الرنين المغناطيسي النووي ^1H ، ^{13}C . 2-(2-(prop-2-nyloxy)ethoxy)ethanthioacetate 171 تم تخليقه لغرض تحقيق تعدديه الارتباط مع المركبات النهائيه عن طريق تفاعل click chemistry ومن ثم سوف يتم ازاله مجموعه الثايو اسيتيت لتمكن ارتباطها مع جسيمات الذهب النانويه.

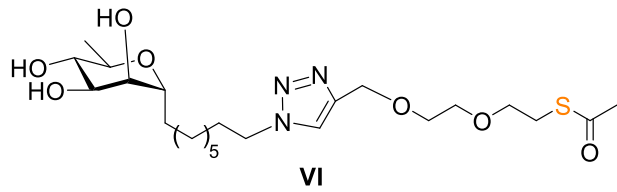
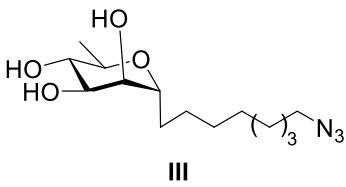
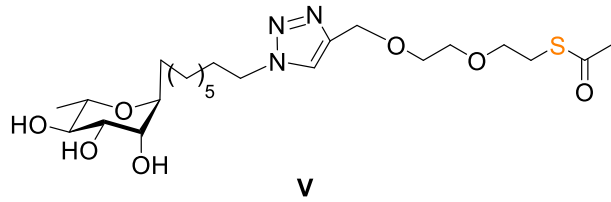
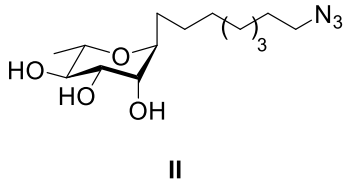
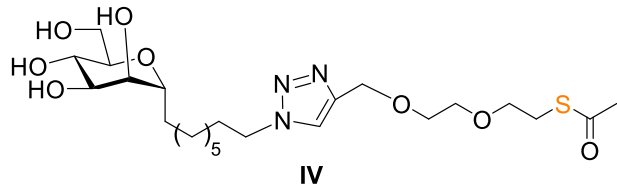
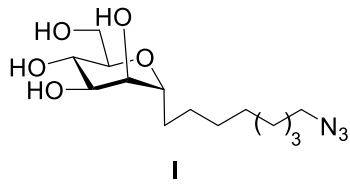

الشكل (أ): مركبات الهدف الأولية I , II , III , IV , V , VI لاجل ارتباط الجسيمات النانوية الملزمة لتحقيق التعددية.

Dissemination

The following presentations were based on work described in this thesis:

1. The 34th Annual Young Scientist Symposium, Bangor University on 28th June 2019, oral presentation.
 - The first prize for the best oral presentation.
 - The Andrew Johnstone Prize 2019, presented by the School of Chemistry, Bangor University.
2. The Biological and Medicinal Sector (BMCS) postgraduate biological and medicinal chemistry Symposium of the Royal Society of Chemistry, Cambridge University on 11th December 2018, poster and short oral presentation.
3. Glycobiotechnology 2018 (IBCARB), University of Manchester, 3-4 September 2018, participated at the meeting and part of work described here was presented by Dr M. Lahmann.
4. The 33rd Young Scientist Symposium, Bangor University on 22nd June 2018, poster and short oral presentation.
5. The 32nd Annual Young Scientist Symposium, Bangor University on 3rd July 2017, oral presentation.
6. The 31st Annual Young Scientist Symposium, Bangor University on 19th July 2016, oral presentation.
7. University College Dublin, Trinity University Dublin, Bangor University Carbohydrate Chemistry Meeting, Bangor University, 9-10 June 2016, oral presentation.

CHAPTER 1

Carbohydrates

1.1 Carbohydrates in Our Life

Carbohydrates, e.g. glucose and *N*-acetyl glucosamine, are one of the most important class of organic molecules in Nature. Carbohydrates play a crucial role in biological life, e.g. cellulose and *N*-acetylmuramic acids are carbohydrates that are important for structural characteristics of the cell wall of plants and bacteria. Monosaccharides can be linked together to form oligosaccharides and can differ in the stereochemical configuration and in size. Carbohydrates can also be linked to lipids and proteins. These glycoconjugates can take part in cell-cell interactions biological processes which makes carbohydrates one of the most important biomolecules in the cellular environment.^{1, 2}

1.2 Carbohydrates – Structure and Conventions

Carbohydrates are simple organic compounds. The name comes from ‘hydrated carbon’. The empirical formula of common carbohydrates is $C_n (H_2O)_n$. In their structures, carbohydrates, have many hydroxyl groups and usually either an aldehyde or ketone group (**Figure 1**). Two typical examples are D-glucose and D-fructose (**Figure 1 i, ii**). Every sugar is classified as either D or L isomer depending on the anomeric reference atom in Fischer projection. Glycer-aldehyde is the smallest monosaccharide with one stereogenic centre. It occurs as the D sugar where the hydroxy group at the configurational atom is drawn to the right while this hydroxy group is located to the left in the L form (**Figure1 iii, iv**). The number of stereogenic centres increase as the chain length increases. The stereochemistry of monosaccharides is often depicted in Fischer projections. It is a very helpful projection for distinguishing between enantiomers and diastereomers of sugar molecules. However, commonly monosaccharides occur in their cyclic forms as hemiacetals, and in most cases only small amounts of the open chain sugars are present in this equilibrium.³ The cyclisation of monosaccharides gives preferentially 5- or 6-membered rings with a new stereogenic centre at the hemiacetal position (**Figure 2**). The hemiacetal is formed as two epimers, the α and β anomers (**Figure 1 v, vi**). In the Fischer projection, the α anomer is the stereoisomer where the exocyclic oxygen atom at the anomeric

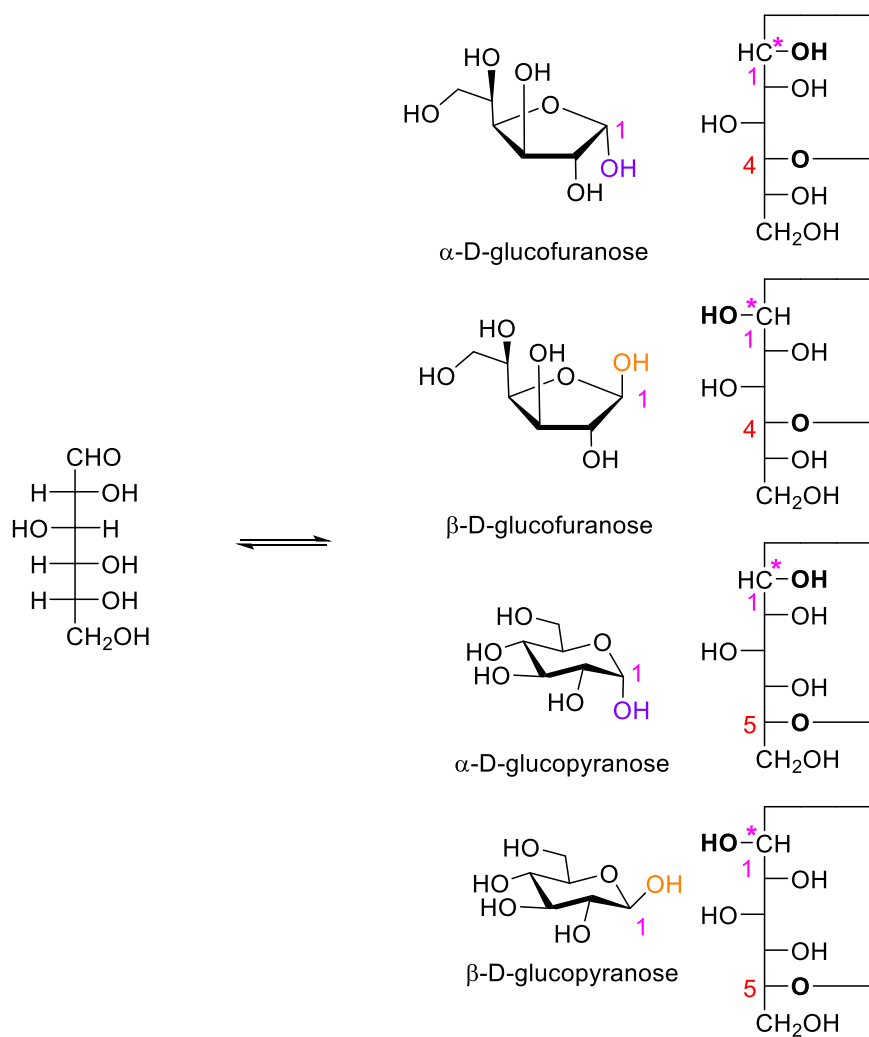

Figure 2: All five D-glucose isomers are in equilibrium in an aqueous solution. Pyranose and furanose are formed for both anomers. The anomeric carbon is indicated with *. Position 4 or 5 are the configurational reference atoms.⁴

In the process of mutarotation, the ratio of the α and β anomers in their pyranose and furanose forms are in equilibrium with each other depending on the stability and hence the anomeric effect (**Figure 3**).

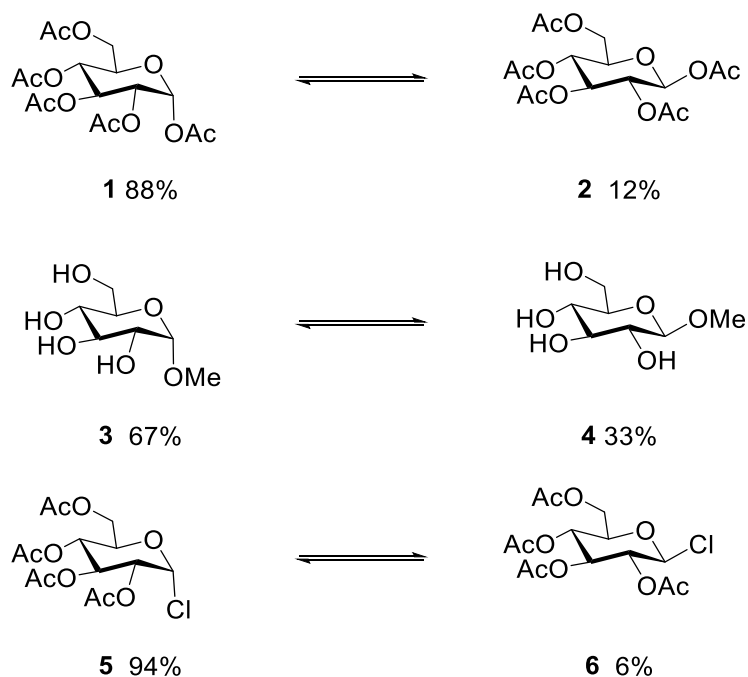

Figure 3: The equilibrium of α - and β -D-glucopyranose derivatives.

A pyranose ring with electronegative substituents on the anomeric carbon atom such as alkoxy, acetoxy, and halogen prefers an axial rather than equatorial orientation.⁵ One of the oxygen's non-bonding electron pairs in the ring stands anti-periplanar to the C-X bond if the electronegative substituent is positioned axial at the anomeric carbon. The possibility of this lone pair to contribute to resonance structures and thus increasing stability is called the anomeric effect (**Figure 4**).^{6,7}

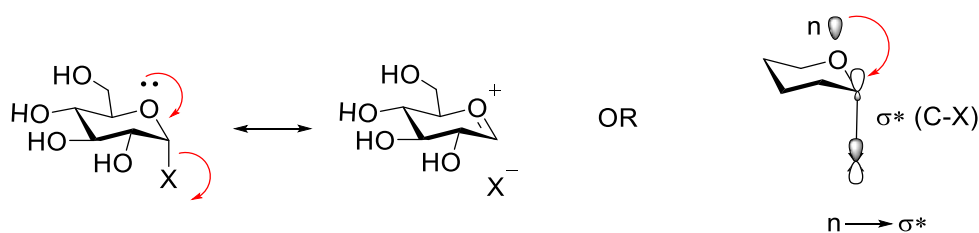

Figure 4: An orbital description of the anomeric effect: Overlap of a non-bonding lone pair with the σ^* orbital of an axial substituent.

1.3 Protecting Groups

Protecting groups are one of the most powerful tools for controlling regio- and stereo- selectivity in organic reactions. Sometimes, several reactive functional groups would react unselectively under specific reaction conditions. In order to achieve selectivity, protection groups are introduced to mask a functional group when a chemical reaction requires selectivity in a multifunctional molecule. Protecting groups should be stable to a broad range of conditions, easily separated from other products and removed in good yields under appropriate conditions.⁸ An orthogonal protection strategy allows the selective deprotection of a protecting group in the presence of other protective groups. This applies to both temporary and permanent protecting groups. Protecting groups also affect the reactivity of carbohydrates by electronic and steric effects (**Figure 5**).

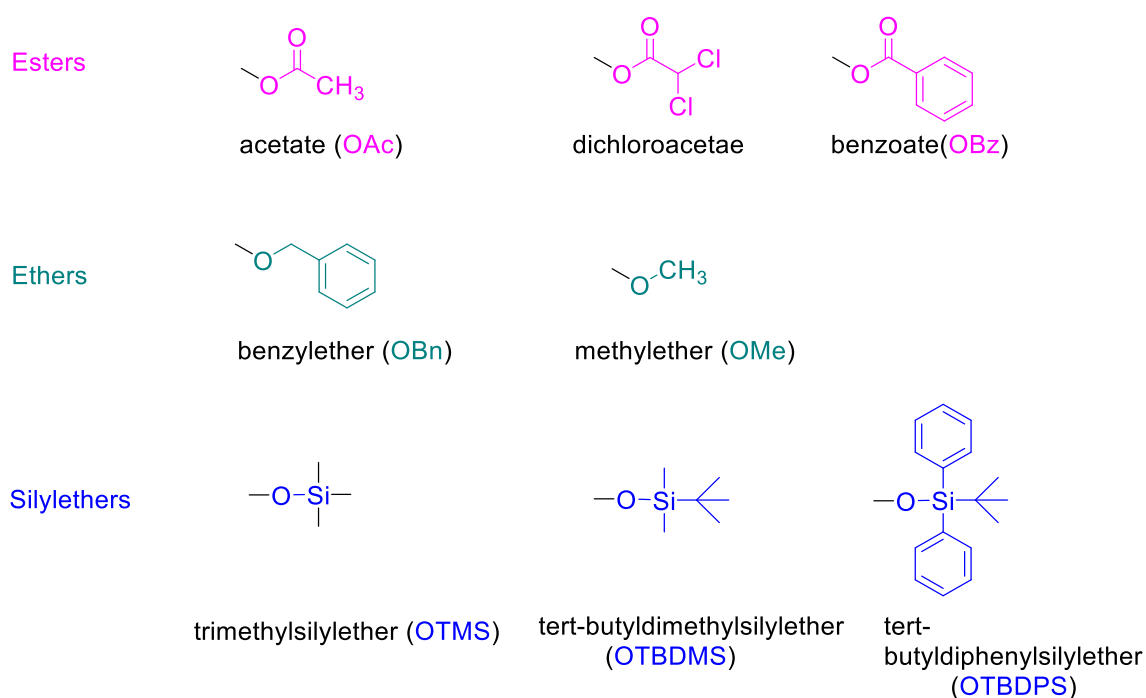

Figure 5: Some common and very efficient groups used to protect hydroxyl groups with permanent and temporary protecting groups.

A challenge in carbohydrate chemistry is the control of the stereospecificity when forming glycosidic bonds. Glycosidic linkage formation requires a reactive electrophile formed by activation of a glycosyl donor that in turn reacts with a nucleophile, the glycosyl acceptor, to produce α/β -glycosides.⁹

Regioselectivity can be controlled via participating group effects, e.g., on the 2-or 6-position.¹⁰

Cleavage of the leaving group on the anomeric centre leads to the formation of a stabilised oxocarbenium ion as intermediate. Participating groups like esters in the 2-position, block the nucleophilic attack to one face of the ring depending on the orientation of the participating group due to the possibility to form an acyl-oxonium intermediate (**Figure 6**).¹¹

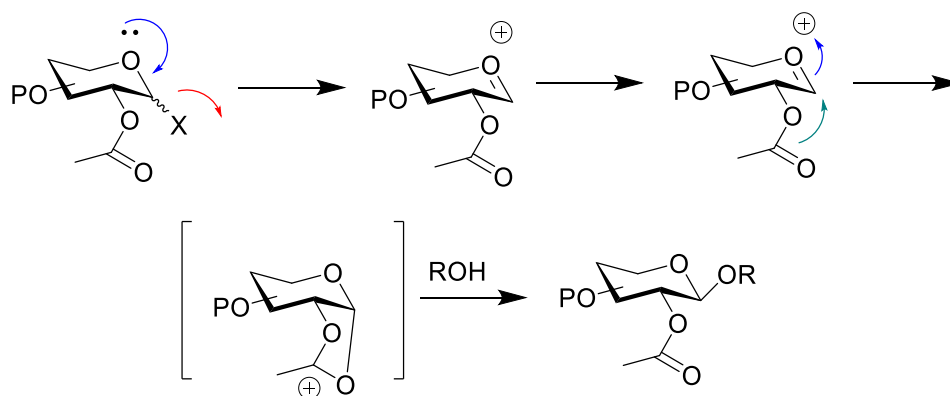

Figure 6: Participation of a protecting group to control the orientation of the anomeric linkage.

P= protecting group, X= LG, ROH= glycosyl acceptor.

1.4 Glycosylation

Most larger carbohydrate containing compounds, as oligosaccharides, polysaccharides and glycoconjugates contain glycosidic linkages (**Figure 7**).¹ This linkage can join two sugars or non-sugars in a process known as glycosylation. A glycosylation takes place when displacing the leaving group of a glycosyl donor with a hydroxyl or another functional group of the glycosyl acceptor to create a new chiral centre and a new glycosidic linkage. These reactions play therefore an important role in carbohydrates synthesis.

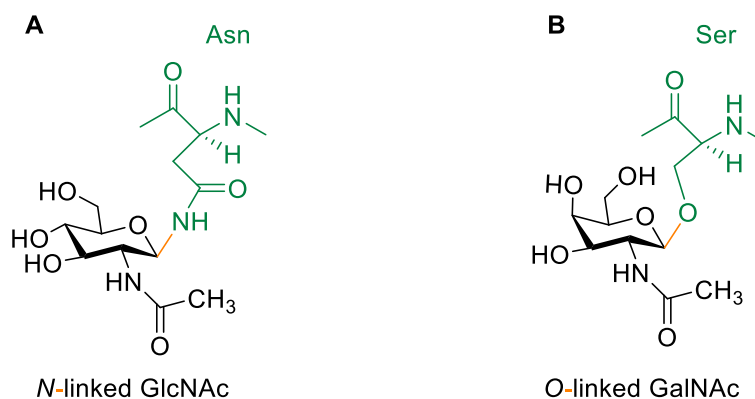

Figure 7: The side chain of proteins links a carbohydrate via a glycosidic bond, here asparagine (*N*-linked) or serine (*O*-linked).¹

O-glycosides, *N*-glycosides or *C*-glycosides are types of glycosides with α - and β - or 1,2-*cis* and 1,2-*trans* glycosidic linkages depending on nomenclature. α -Glycosides such as D-glucose, D-galactose and β -glycosyl for D-mannose are 1,2-*cis* glycosyl residues as well as 1,2-*trans* glycosyl residues such as, β -glycosides for (D-galactose and D-glucose) and D-mannose for α -glycoside. There are other types of glycosides that are neither *cis* nor *trans* when the C-2 position is not substituted by a heteroatom (deoxy-glycoside) (**Figure 8**).¹²

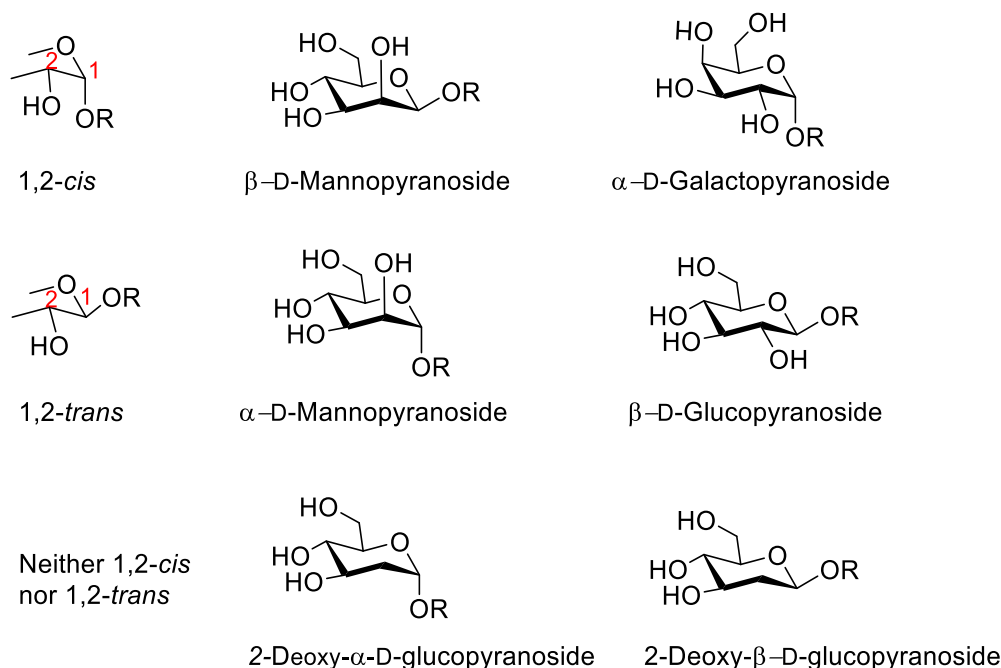

Figure 8: Examples of 1,2-*cis*, 1,2-*trans* and neither 1,2-*cis* nor 1,2-*trans* *O*-glycosides.¹²

In the glycosylation reaction, nucleophilic displacement occurs at the anomeric centre. This reaction follows formally according to a S_N1 mechanism and forms either a *cis* or *trans* glycosidic linkage depending on the presence of a participating or a nonparticipating group at the glycosyl donor. During this reaction, a carbocation, glycosyl cation, forms due to departure of the anomeric leaving group from the glycosyl donor initiated by an activator (**Figure 9**).

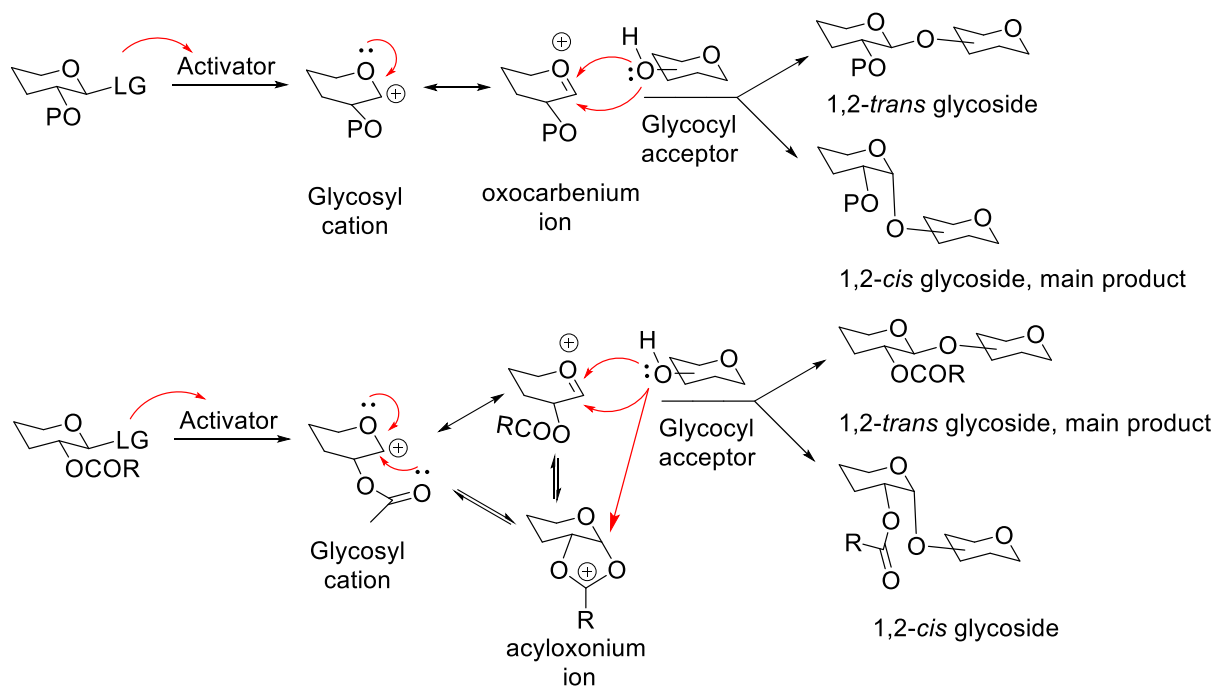
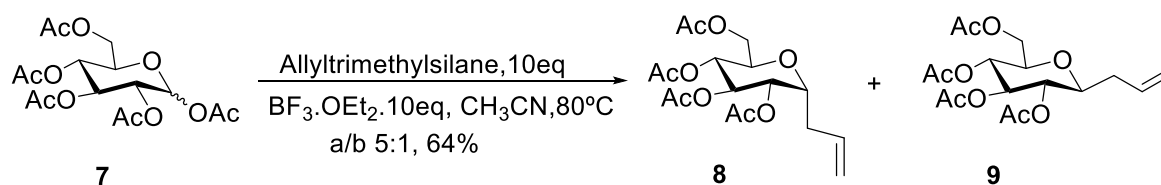

Figure 9: The mechanism of a glycosylation with and without participation of neighbouring groups.

1.5 C-Glycosides

Other types of glycosides can be defined if the binding partner is not an alcohol but an amine or thiol leading to so-called *N*- and *S*-glycosides.¹³ The term *C*-glycoside is frequently used in the literature for compounds where a carbon-carbon bond forms a glycoside-like structure at the pseudo-anomeric position (e.g. see compound **8** and **9** in **Scheme 1**). However, the usage of the term '*C*-glycoside' is "strongly discouraged" by the IUPAC recommendations on the carbohydrate nomenclature from 1996 because "glycosides are hydrolysable whereas the C-C bond of '*C*-glycosides' is usually not".¹⁴ Hence, this term is a misnomer and should not be used. According to IUPAC, the preferred name for this type of compound is "*C*-glycosyl compound". Nevertheless, the term "*C*-glycoside" found its way into the formal chemistry terminology and literature and will be used throughout this thesis to describe this kind of compounds.



Scheme 1: Example of an allyl-*C*-glycoside, the peracetylated 3-(1'-deoxy- α -D-glycopyranos-1'-yl)-1-propene **8** and **9**.¹⁵

While *O*-linked glycosides are metabolised by glycosidases by cleaving the glycosidic bonds,¹⁶ *S*-glycosides are stable to enzymatic hydrolysis but not to acidic conditions, which leads to saccharides and free thiols.¹³ *C*-glycosides differ from *O*-glycosides and *S*-glycosides as they have no anomeric centre, i.e., 1-(α -D-mannopyranosyl)propane type linkage. Thus, *C*-glycosides are stable against enzymatic and acidic cleavage and therefore of interest due to their pharmacological stability, e.g. as enzyme inhibitors and glycomimetics^{13, 17, 18}

Methods for the preparation of *C*-glycosides have been known for a long time.¹⁹ A common way is to use either an acetate (**Scheme 1**) or methoxy group (**Scheme 2**) as leaving group in the anomeric centre in combination with a Lewis acid and allyltrimethylsilane.

Bertozzi and Bednarski in 1992 used the above method to synthesise the intermediate *C*-mannosyl compounds **11** and **12** from methyl tetra-*O*-benzyl- α -D-mannopyranoside **10** for studying their inhibitory activity towards the receptor-adhesion of *E. coli* to yeast cells.²⁰

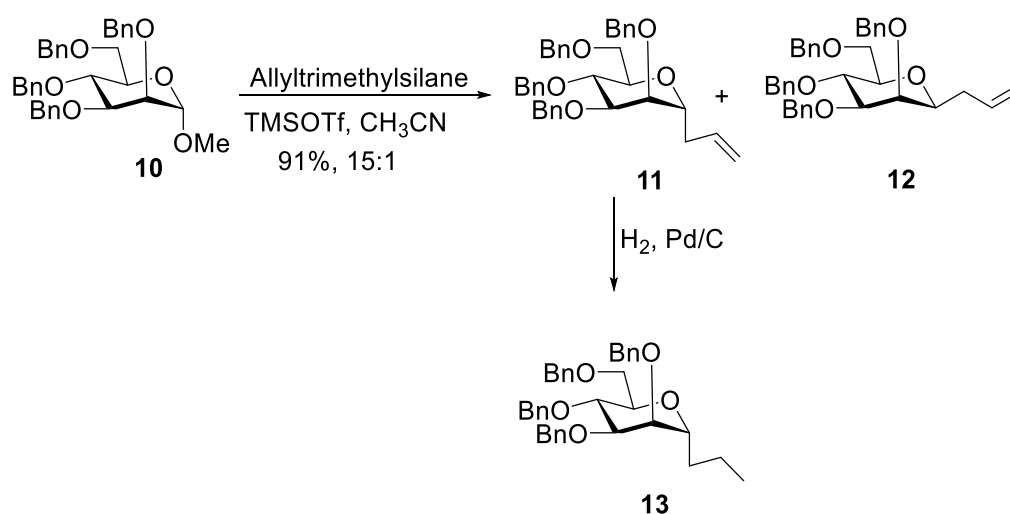

Scheme 2: Synthesis of 3-(tetra-*O*-benzyl- α -D-mannopyranosyl)propene using allyltrimethylsilane and TMSOTf. The ratio of α - and β - was 15:1 in an overall yield of 91%.

After reduction of the double bond in compound **11** using H₂ and Pd/C, 1-(α -D-mannopyranosyl)propane **13** achieved an inhibition of yeast cells at a concentration of 7mM with a relative inhibition compared to methyl α -D-mannopyranoside of 9.6. In the same publication, a biotinylated derivative of **16** was conjugated to avidin producing the tetravalent conjugate **17**, this compound showed a relative inhibition of 1340, indicating a multivalent effect (**Scheme 3**).

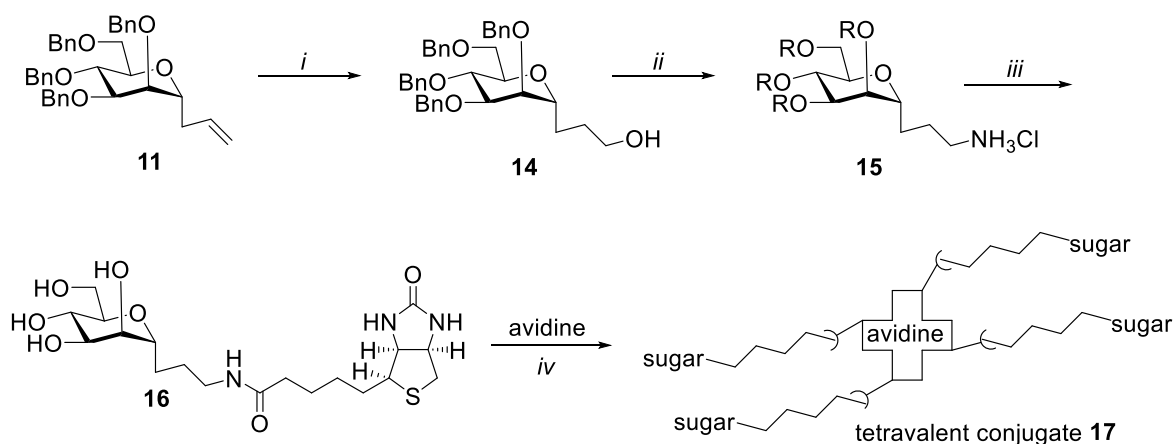

Scheme 3: Synthesis of 3-(tetra-*O*-benzyl- α -D-mannopyranosyl)propene. *i.* (a. hydroboration (9-BBN); b. H_2O_2); *ii.* (a. MeCl , Et_3N ; b. tetrabutylammonium azide, Bu_4NN_3 , CH_3CN ; c. H_2 , $\text{Pd}(\text{OH})_2$, HCl); *iii.* NHS-Biotin, Et_3N , 1:1 DMF-MeOH.²⁰

A similar approach has been used, when synthesising *C*-glucopyranosyl compound **20**. Here, the trichloroacetimidate group was used as a good leaving group at the anomeric centre. Only the β -anomer product was obtained from glycosyl donor **18** with resorcinol dimethyl ether **19** in the presence of $\text{BF}_3 \cdot \text{OEt}_2$ (70% yield, **Scheme 4**). In this study, it was observed that the choice of the Lewis acid (e.g. $\text{BF}_3 \cdot \text{OEt}_2$) and leaving group (e.g. trichloroacetimidate) was crucial to achieve an optimal yield.

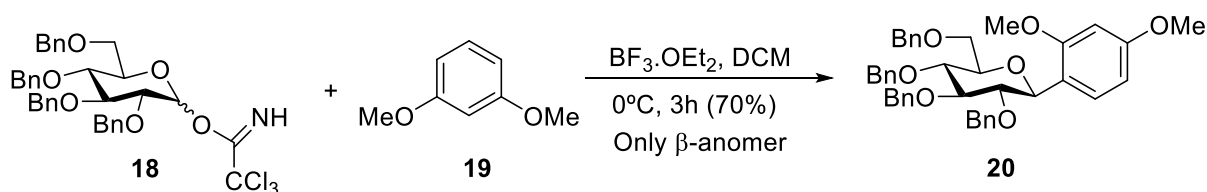

Scheme 4: Synthesis of β -*C*-glucopyranoside **20** using trichloroacetimidate in the presence the Lewis acid $\text{BF}_3 \cdot \text{OEt}_2$ to give **20** in 70% yield.²¹

Another way to synthesise *C*-glycoside compounds is via oxidation of the hydroxyl group on the anomeric centre (**Scheme 5**).²²

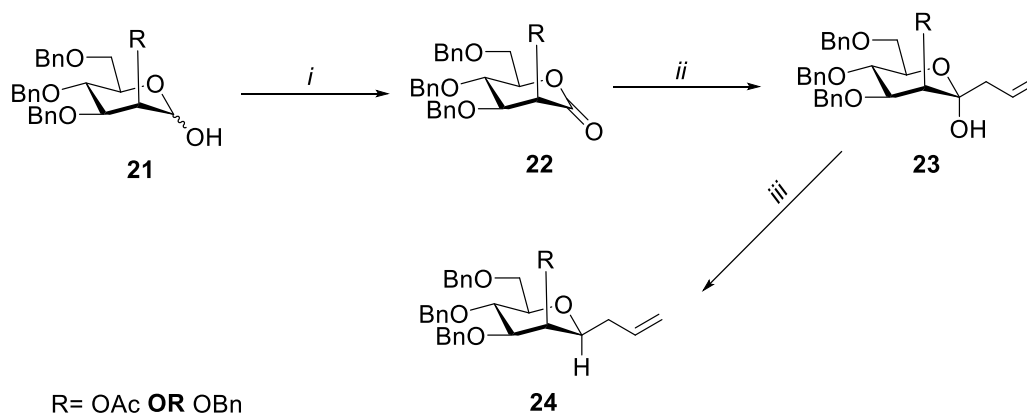

Scheme 5: Synthesis of allyl-*C*-glycosyl compounds via oxidation of secondary alcohol. Reagent and conditions: *i*. TPAP (5 mol %), CH₃CN, rt, 10 min, 90%; *ii*. (allyl)MgBr, THF, -78°C, 1.5 h, 70%; *iii*. Et₃SiH, TMSOTf **OR** BF₃.OEt₂, CH₃CN, rt, 5 min, 47%.

Differences in stereoselectivity depending on the protecting groups on C2 have also been observed. Due to anchimeric assistance the stereochemistry using acetyl groups in C2 gave a higher stereoselectivity (α : β 20:1) compared to using benzyl ethers at C2 (α : β 1:1).²²

Potassium organotrifluoroborate is one of the most stable organoboron reagents which exhibits wide-ranging applications in direct *C*-glycosylation chemistry. This method has been used for C-C bond formation by coupling potassium organotrifluoroborates with sugar oxocarbenium ions.¹⁷ Zeng *et al* employed this method evaluating different leaving groups at anomeric centre (**Scheme 6**).

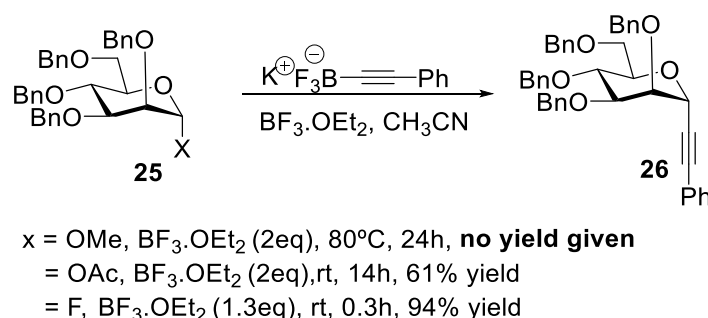

Scheme 6: Direct *C*-Glycosylation of Potassium Phenylethynyltrifluoroborate.

Another one-step method to obtain C-glycosyl compounds is via the synthesis of cyanoglycosyl compounds.²³

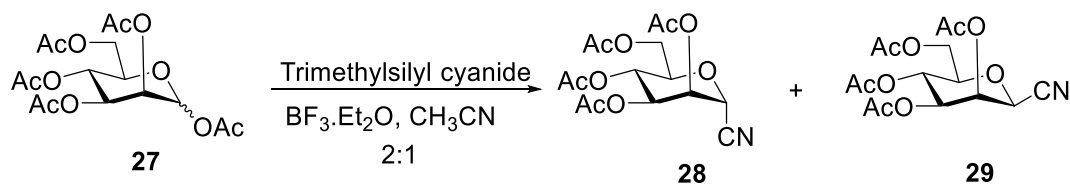

Scheme 7: Synthesis of cyanomannoside. The mixture of α/β isomers was 2:1 in this reaction.

These compounds exhibited good efficacy in mouse models for acute and chronic UTI (**Scheme 8**).

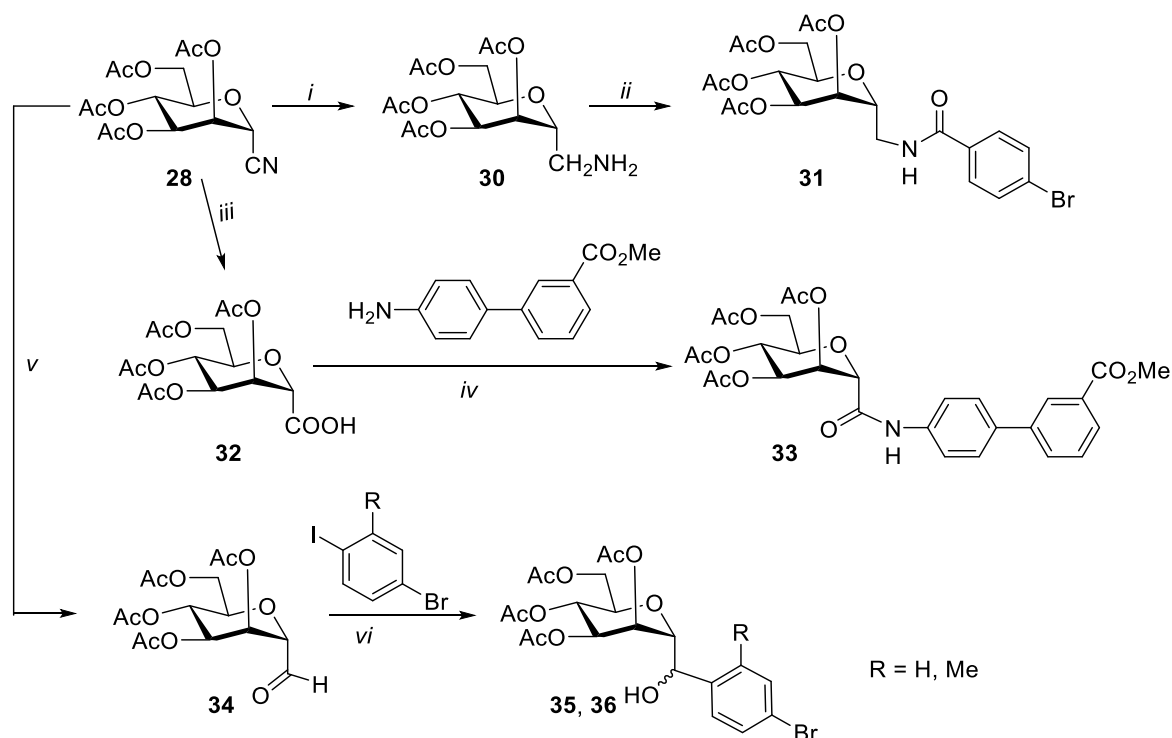

Scheme 8: Synthesis of C-mannosides from cyanomannoside: *i.* LiAlH₄, THF, rt; *ii.* 4-bromobenzoyl chloride, pyridine, rt; *iii.* 25% HCl aq, 50 °C; *iv.* HATU, DIPEA, 0 °C to rt, DMF; *v.* DIBAL, DCM, -78 °C; *vi.* BuLi Et₂O, -78 °C to -20 °C.

A fundamentally different approach to obtain C-glycosyl compounds is by using β -dicarbonyl compounds as 2,4-pentadienone in the presence of NaHCO₃ (**Scheme 9**).²⁴

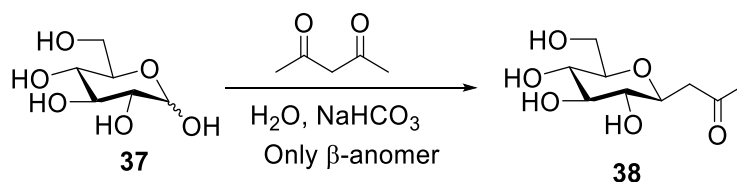

Scheme 9: Synthesis of 1-(α -D-Glucopyranosyl)-propan-2-one. The reagents and conditions: 2,4-pentadione, NaHCO₃ (4 eq), 8:2 water-THF, stirring at 90 °C, 24 h, **only** β isomer in yield of 85%.

The one-pot Knoevenagel condensation-retro Claisen-decarboxylation sequence is a useful addition to the repertoire of *C*-glycosides forming reactions. This reaction uses an (un)protected carbohydrate and β -diketone usually in aqueous media under basic conditions. The yield of this reaction is influenced by the reaction conditions such as reaction time, temperature and the nature of the base. Predominantly, this reaction leads to formation of β -*C*-glycoside compounds (**Scheme 10**).²⁵

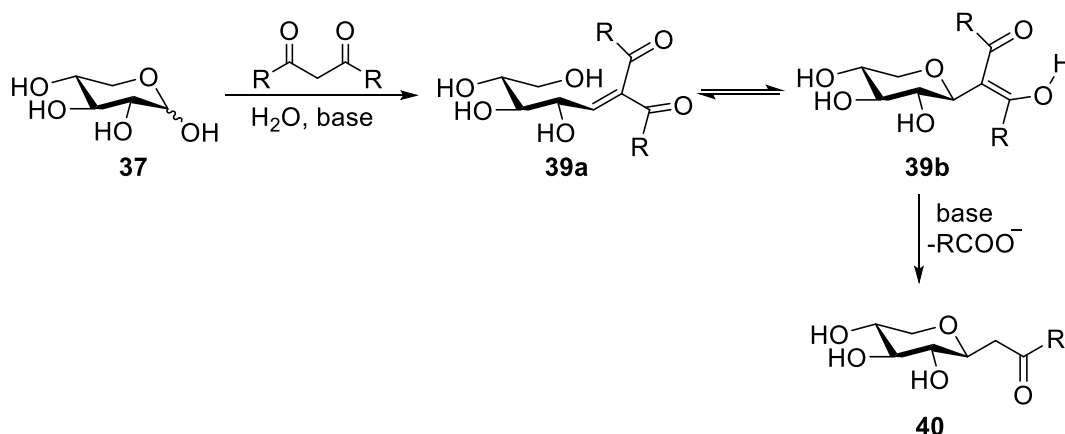

Scheme 10: The abbreviated mechanism of the formation of β -*C*-xylose compounds.²⁵

1.6 Previous Synthesis of *C*-glycosides as Inhibitors

The above presented methods for the preparation of *C*-glycoside compounds are primarily applicable for relatively simple aglycones. In order to synthesise compounds with more complex aglycones, generally extension at the easily introduced double bond of the propenyl group is carried out. There are a number of options. One option is using the cross-metathesis, e.g. using Grubbs catalysts which is widely used in synthetic organic chemistry.²⁶

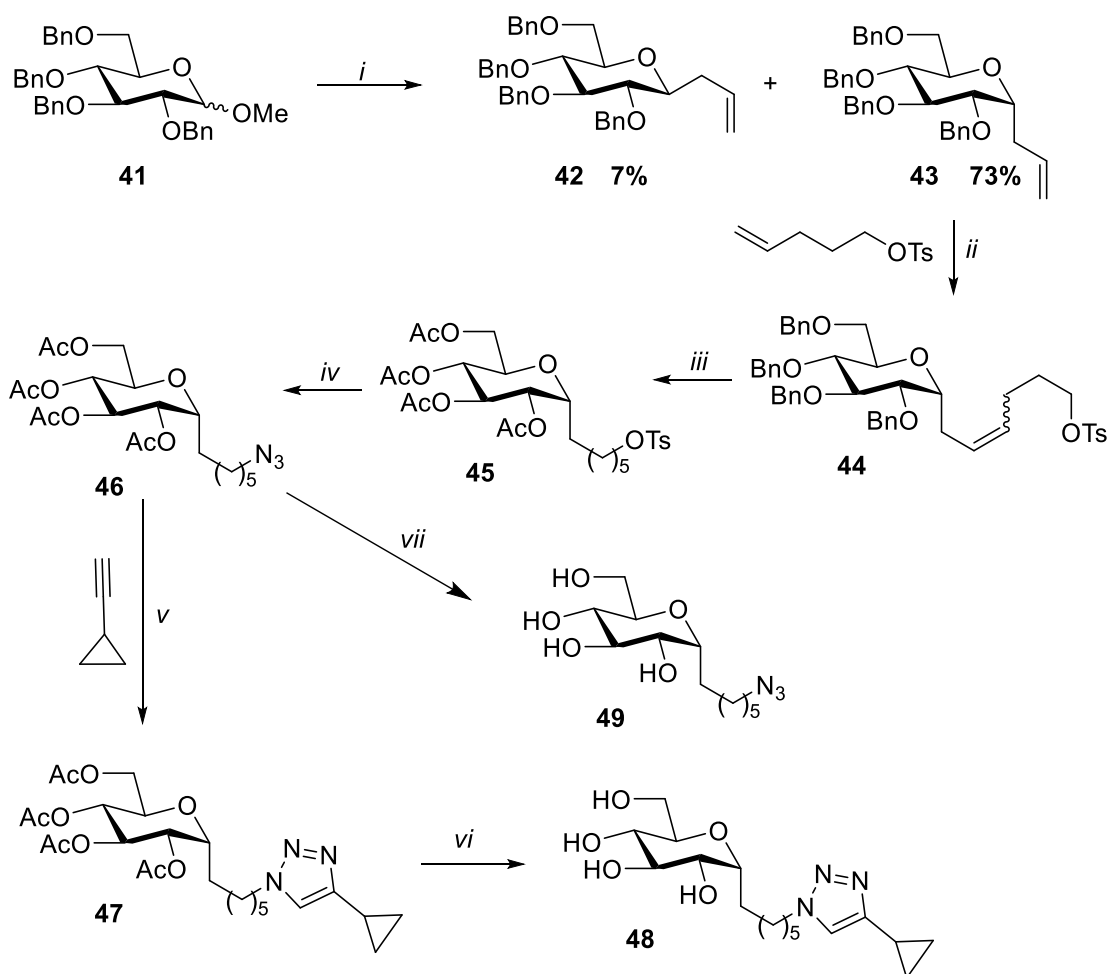

Scheme 11: Synthesis of azide-armed C-glycosides. Reagents and conditions: *i.* allylTMS, TMSOTf, MeCN, rt, 80%; *ii.* Grubbs II cat., DCM, rt, 68%. *iii.* Pd/C 10%, H₂, THF/MeOH, rt → Ac₂O, DMAP, pyridine, rt, 68%; *iv.* NaN₃, DMF, rt, 91%; *v.* CuSO₄·5H₂O, sodium asc., DMF/H₂O, 80°C, 90%; *vi.* MeOH, Amberlite IRA400, rt, 89%; *vii.* MeOH, Amberlite IRA400, rt, 85%.²⁶

In a recent publication, the first step was allylation of the methyl-benzylated glucoside **41** to obtain a pseudo anomeric mixture of C-glycoside **42** and **43**.²⁶ The linker was introduced using 4-penten-1-yl tosylate under cross-metathesis reaction conditions. While the Hoveyda-Grubbs II catalyst led to an inseparable mixture of the expected compound, the required product **44** was obtained using Grubbs II catalyst at room temperature in 68% yield (**Scheme 11**).

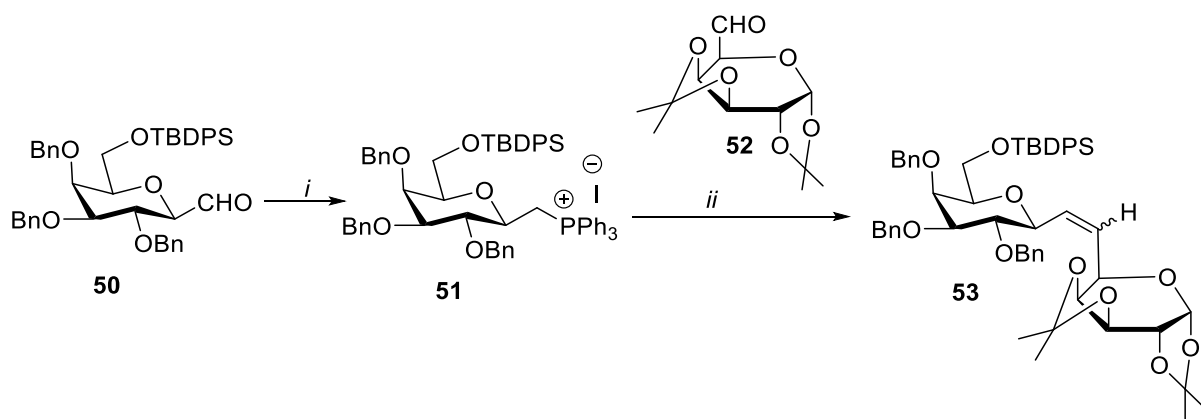

Scheme 12: *i.* a. NaBH₄, MeOH, rt b. imidazole, I₂, PPh₃, 80°C c. PPh₃, 120°C, 63%; *ii.* dialdogalactopyranoside, BuLi, THF, -50°C, mixture of *E/Z* geometric isomers in 1:9 ratio (*J* = 11.5 Hz), 70% overall yield.

Another alternative is to use the Wittig reaction, which requires a carbonyl component and a Wittig salt. Dondoni *et al* used the Wittig coupling by joining sugar aldehyde **52** and with the sugar derived Wittig salt **51** (**Scheme 12**).²⁷

1.7 Participating Groups

Benzyl (OBn) and azide (N₃) groups are the most common non-participating groups. In this case, the nucleophile will attack the anomeric centre from either the bottom or the top face of the ring and give limited selectivity.

In order to achieve selectivity, protecting groups of esters, e.g., OAc or OBz groups assist to form a stable glycosyl cation, oxocarbenium ion, via the resonance from O-5.¹²

As mentioned earlier, glycosylation can be influenced by the choice of the protecting groups in the C-2 position (see **Scheme 13**).²⁸

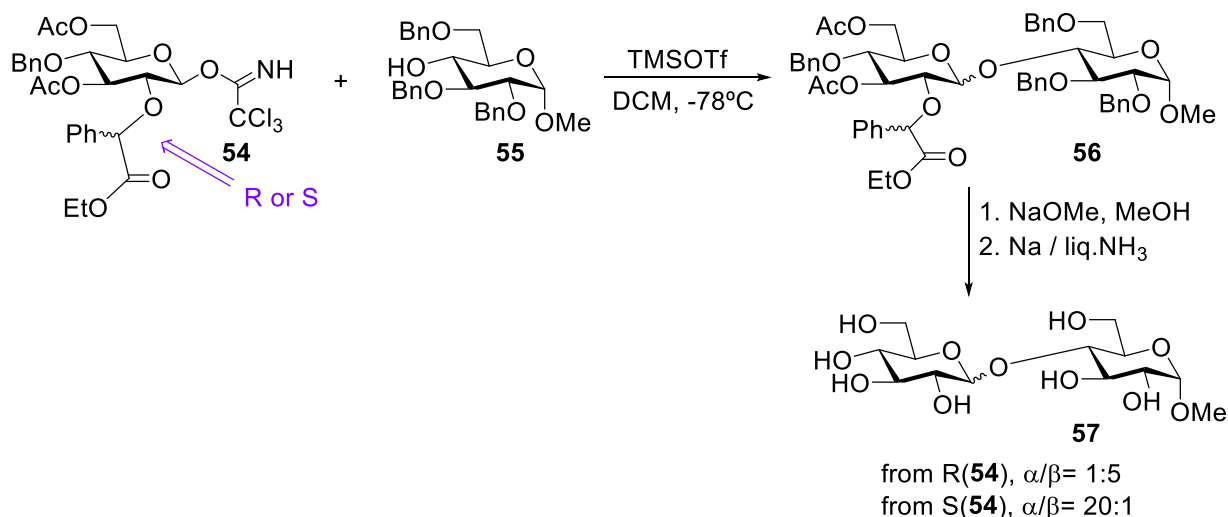

Scheme 13: Control of the stereoselectivity in the glycosylation depending on the chirality of the 2-protecting group in the glycosyl donor **54** to give high selectivity for S.²⁸

However, protecting groups at the C-3, C-4 or C-6 position can also affect the stereoselectivity via remote participation.²⁹ **Scheme 14** shows an example of a highly α -selective galactosylation using the thiol galactosyl donor **58** with a remote electron-donating group participation at C-4.³⁰

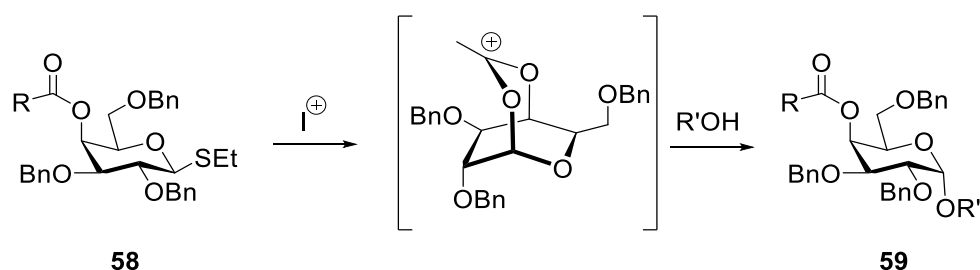

Scheme 14: Neighbouring group participation at C-4 of *O*-acyl group can perform highly α -Stereoselective glycosylation by a remote effect.²⁹

Another example of remote participation, the formation of an α -linkage has been achieved using a glycosyl donor with a (*S*)-(phenylthiomethyl)benzyl moiety **60** as protecting group at the C-6 position. On the other hand, the 6-*O*-benzyl ether and 6-*O*-acetyl ester derivatives provided only 1:1 and 4:1-mixtures of anomers, respectively (**Scheme 15**).³¹

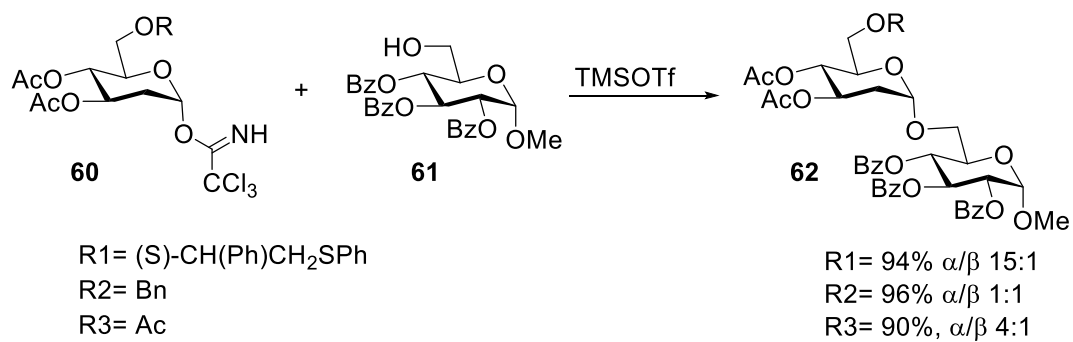

Scheme 15: Scheme of a stereoselective glycosylation with a (S)-(phenylthiomethyl)benzyl moiety at the C-6 yielding preferably the α -anomer.³¹

CHAPTER 2

Escherichia coli and lectins

2.1 *Escherichia Coli* (*E. coli*)

Escherichia coli (*E.coli*) (**Figure 10**)³² is a Gram-negative, anaerobic, rod-shaped bacterium, that is frequently found in anaerobic environments. The majority of *E.coli* are harmless and some of these strains are living in our gut and produce vitamin K2.³³ There are some serotypes that cause infections. Some *E. coli* strains cause gastric infection including food poisoning due to contaminated food.³³ Urinary tract infections (UTIs) can also be caused by *E.coli*.³⁴

E.coli have hairy surface organelles, the fimbriae and pili. Some *E.coli* can adhere to the normally sterile human uroepithelium and causes urinary tract infections (UTIs) using the adhesin found of the tip of the fimbriae, the FimH.^{35, 36}

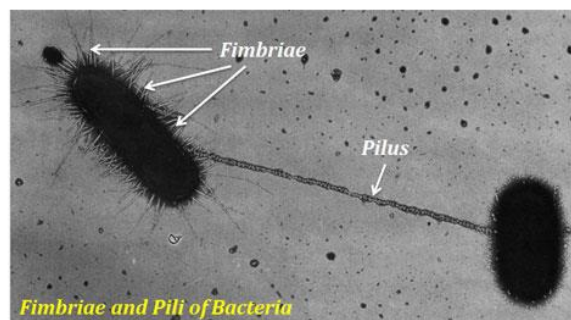

Figure 10: *E.coli* under an electronic microscope.³²

2.2 The Uropathogenic *E.coli* (UPEC)

Uropathogenic *E. coli* (UPEC) is the major cause of UTIs.³⁷ These bacteria have developed a mechanism to colonise a host through adhesion to the body's tissues. The majority of UTIs begin in the bladder, which is the main target organ, causing cystitis as a result of the bacterial colonisation.³⁸ However, the infection can ascend to the kidneys through the ureter causing acute inflammation (pyelonephritis) in the upper part of the urinary tract if a cystitis is not treated.³⁹

The urinary tract is a sterile environment⁴⁰ and protected primarily by the flow of urine and by antimicrobial compounds secreted by the body and neutrophils.⁴¹ However, UTIs have become an extremely prevalent problem despite these natural defences and the use of antibiotics.⁴²

Previous studies have shown that about 60% of women in the United States are infected by UPECs.⁴³ Women are the most vulnerable to UTIs caused by UPECs⁴⁴ because the urethra is shorter in women than in men.⁴⁵ The symptoms of UTI may include pain on urination and urgency (cystitis), pain, nausea and fever in the lower back (pyelonephritis) and the infection can become recurrent and chronic.⁴⁵

As mentioned above, colonisation of UPECs to host tissue is mediated by adhesins. These adhesins are components of proteinaceous threadlike organelles called pili or fimbriae. They are located on the bacterial surface within the outer membrane (Figure 12).⁴⁶ These adhesive structures are responsible for binding with D-mannosylated proteins located on epithelial cells in the bladder lining.⁴⁷ Adhesins commonly target host ligands⁴⁸ including protein structures and carbohydrate epitopes, the latter usually present as parts of glycoproteins or glycolipids.⁴⁹

The initial step for a UPEC infection is the interaction of the epithelial bladder cells with the bacterial adhesives and thus associated with the structure of the type1 pili of FimH.⁵⁰

Type 1 pili consist of a pilus rod, a tip fibrillum, and a transmembrane section. The short tip fibrillum consists of three subunits, FimF, FimG, and the FimH adhesin (**Figure 11**).^{51,52}

FimH is located at the tip of the fibrillum that recognises D-mannosyl residues on the host's glycoprotein.³⁹ This binding through *E. coli*'s FimH adhesin is a crucial step in the infection.⁵³

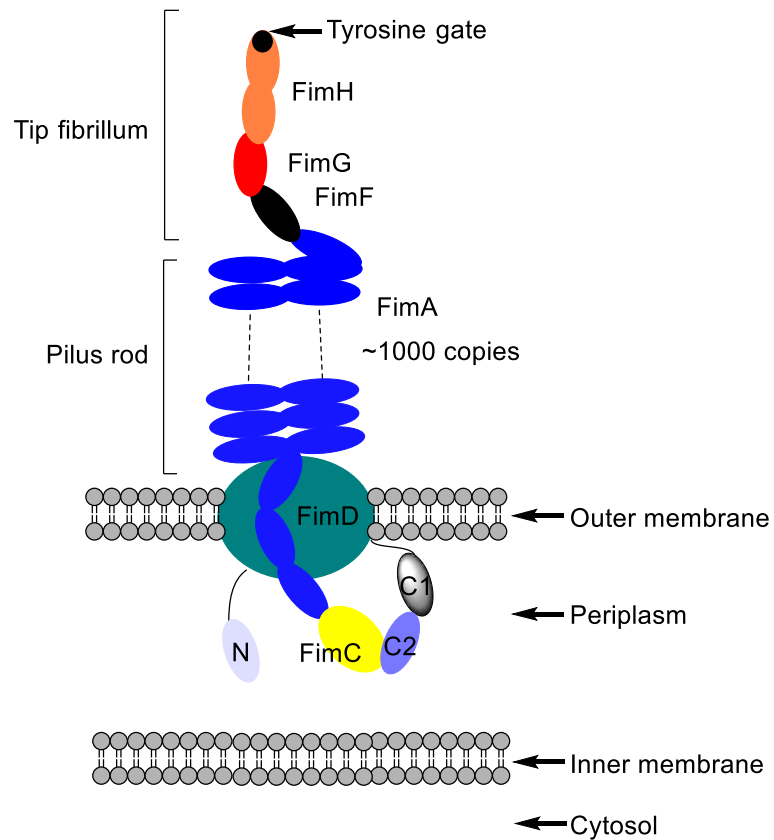

Figure 11: A schematic presentation of a fimbria in *E. coli*. Adaptation from ref.⁵²

UPECs can form intracellular bacterial communities (biofilms) inside the bladder by creating a protective environment of superficial umbrella cells. These cells can resist the host's immune system and antibiotics. Some surviving pathogens can leave these cells and establish a new location of infection and thus give way for recurrent infections despite proper use of antibiotics (**Figure 12**).⁵⁴

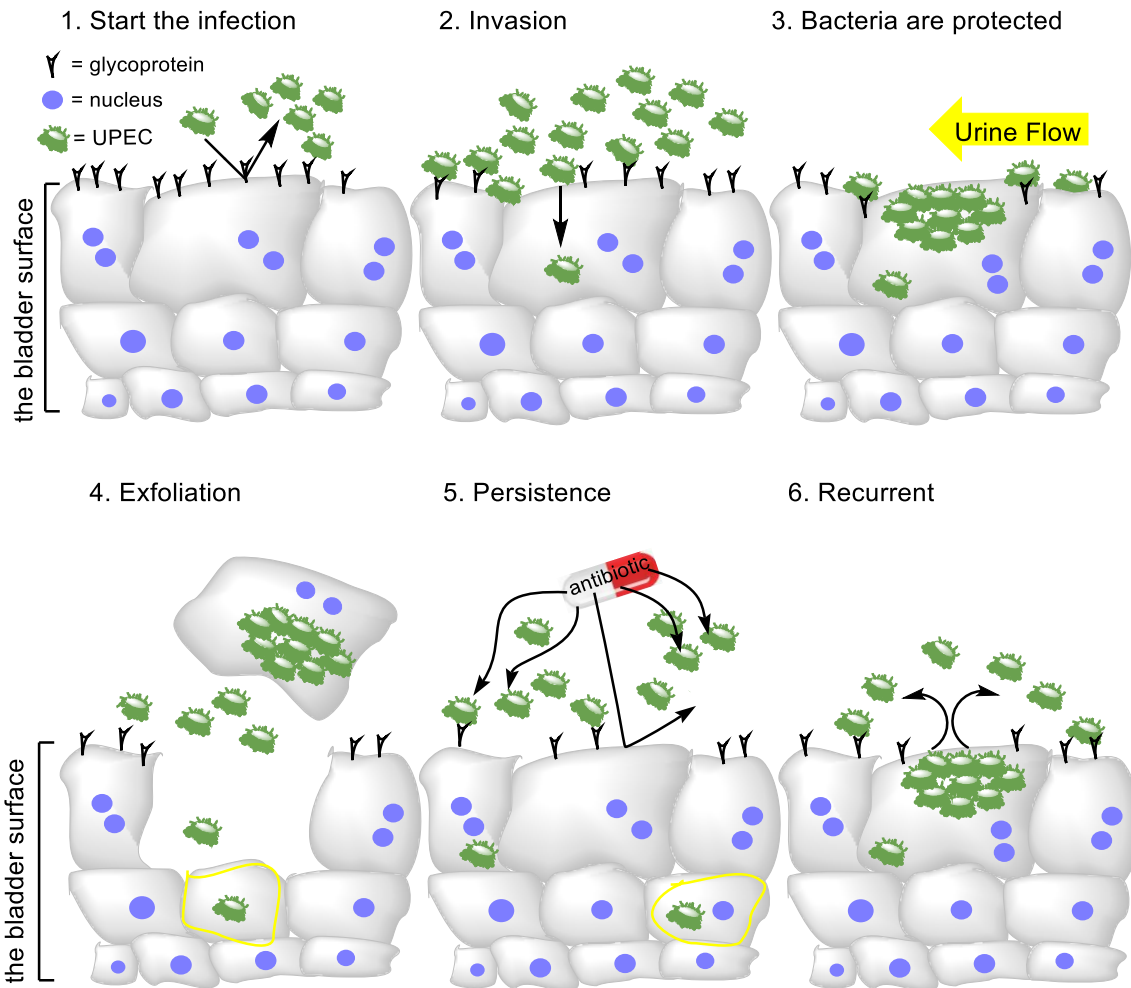

Figure 12: Schematic representation of the development of recurrent UPEC infections within the bladder. 1. UPECs entering the bladder lumen can multiply within the urine and attach to the bladder surface via exposed glycoproteins (UP 1a). 2. Some bacteria invade host's superficial cells. 3. Shearing forces from the urine flow can eliminate many bacteria in the lumen and on superficial cells, however, bacteria enclosed in umbrella cells can still rapidly multiply. 4. An exfoliation of the superficial cells can be induced by the infection, re-establishing bacterial presence within the bladder lumen. 5. Antibiotics can attack bacteria in the bladder lumen and at exposed surface cells but are inefficient towards trapped bacteria (within F-actin, the microfiber produced by actin). 6. Recurrence occurs when something triggers bacterial release back into the bladder lumen.⁴¹

There are two types of adhesins that are linked UTIs, type 1 fimbriae in the bladder and type P fimbriae in the kidney.⁵⁵ The dominant glycoproteins in the urinary tract are uroplakin 1a complexes (UP1a).⁵⁶ These glycoprotein complexes are the prevalent structures exhibited on the urothelium, the multi-layered epithelium found on the inner surface of the mammalian bladder, and thus cover most of the bladder from the inside.⁵⁷

2.3 High Affinity Ligands and Inhibition of Bacterial Binding

The binding site of a protein is the region, which interacts with a ligand to induce a biochemical response and are typically ligand specific (“lock and key”). The type of binding at the binding site is generally noncovalent, and the binding event is usually an equilibrium between a ligand binding or not binding to a receptor with the equilibrium constant defined as: ⁵⁸

$$K = [\text{ligand-receptor}]/[\text{ligand}][\text{receptor}].$$

Both the dissociation constant as well as the association constant can be measured. The monovalent binding of a carbohydrate ligand to a receptor lectin is usually weak ($K_d \approx \text{mMol}$), but can be enhanced to high affinity binding (μMol , nMol) by multivalent presentation of the ligand, the receptor or both. There are a number of methods to determine the K_d value, e.g. by surface plasmon resonance (SPR) or isothermal titration (ITC). During an ITC measurement a ligand is added in defined portions to a receptor. The heat produced during the binding event is measured. The ITC method (**Figure 13**)⁵⁹ has the advantage that it provides not only the K_d values but also thermodynamic data as enthalpy and entropy. It is also able to provide information on the binding mode (stoichiometry) which is of interest for multivalent binding.⁶⁰ A problem is the error associated with the K_d values, since different methods used for determination provide a range of values, e.g. both a K_d of 2.3 mmol ³⁹ and 1.6 mmol ⁶¹ for D-mannose has been reported.

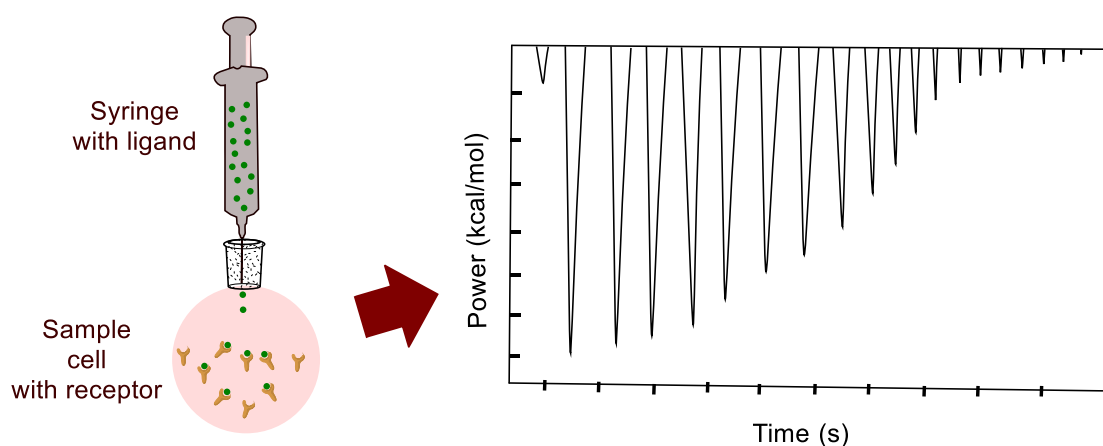

Figure 13: Schematic of ITC cell and injection syringe.⁵⁹

2.4 Inhibitions of The Lectin FimH

Lectins have generally shallow binding sites.⁶² However, FimH is an exception because this lectin has an unusually deep binding site.²³ A natural ligand of FimH are high mannose structures as the core pentasaccharide⁶³ (**Figure 16**)⁴⁷ which is found in almost all N-glycans and exposed also by the high mannose glycoprotein UP 1a expressed by the urinary epithelial cells. Deep in the pocket, seven amino acids are interacting via hydrogen bonding with, e.g., the α 1,3-D-mannoside (Man4) of the core pentasaccharide. Astonishingly, the Man3, and to some extent the GlcNAc2, have mainly a hydrophobic contact with the binding site. These saccharides are interacting with their unpolar pyranoside ring and the aromatic residues of the tyrosines Tyr48 and Tyr137.⁴⁷

An important feature of the FimH protein are the tyrosine residues, Tyr48 and Tyr137. They are lining the hydrophobic cavity of the binding site at the tip of the FimH and create the so-called tyrosine gate together with Ile52 (**Figure 14**). The non-polar face of the glycan sequence interacts with the tyrosine gate of FimH by aromatic stacking interactions (**Figure 16**). The Tyr48 assists to open or close the tyrosine gate in response to the nature of the ligand, whereas the polar mannose binding residues in the pocket are relatively rigid and remain nearly unchanged.⁶⁴

Butyl α -D-mannoside **65** is a high affinity ligand for FimH ($K_d = 0.15$ mM). Compared to α -D-mannose ($K_d = 2.3$ mM), the binding affinity increases to about 15 times with the introduction of the butyl chain. This impact of the additional alkyl chain demonstrates the importance of the hydrophobic contacts and the increased interaction with the tyrosine gate.³⁹

The alkyl tail of the butyl α -D-mannoside extends out of the binding site towards the tyrosine residues, Tyr48 and Tyr137, and isoleucine Ile52, via hydrophobic contacts.³⁹

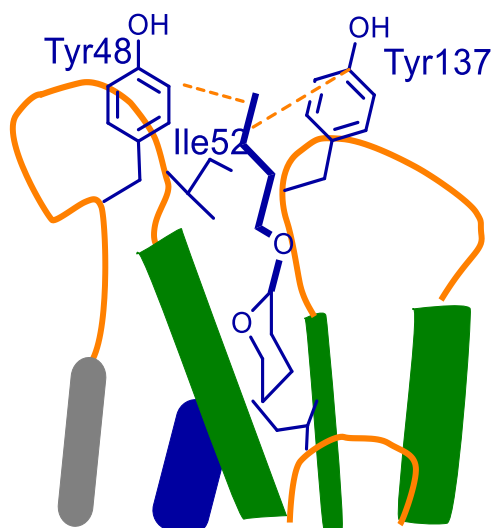

Figure 14: The mannose-binding pocket of FimH, showing the hydrophobic contacts with butyl α -D-mannoside and the Tyr48, Tyr137, and Ile52 residues.³⁹

Despite the larger flexibility expected from the alkyl chain, the affinity reaches its maximum first with seven carbon atoms in the chain (**Figure 15**).³⁹

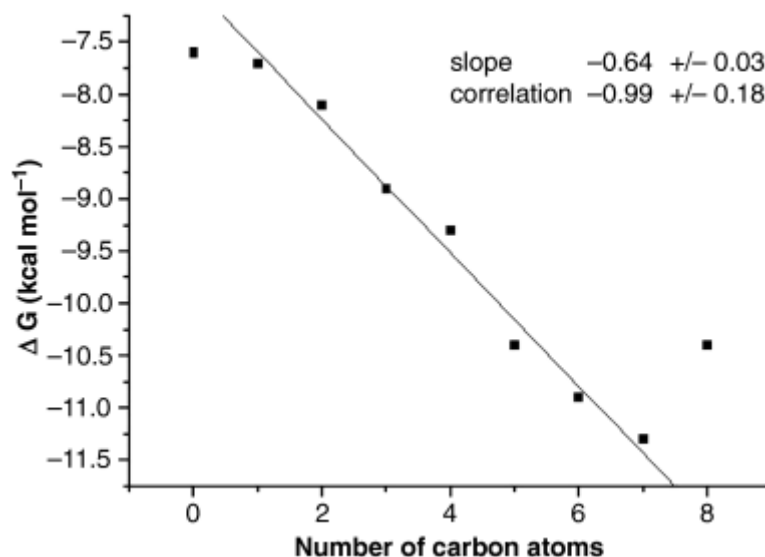

Figure 15: The relationship between the free energy and numbers of carbons.³⁹

Alkyl-*O*-D-mannosides have been demonstrated to be effective inhibitors of *E. coli*'s FimH adhesin. One example is heptyl-*O*-D-mannoside **64** which is a strong inhibitor of FimH, because **64** has an optimised alkyl chain length for interaction with the binding site of FimH.⁴⁷ In

a study, different chain lengths and additional functional groups were compared (**Figure 17**). It was found that the interactions of receptor with the binding site increases with chain length due to increased non-polar interactions with the tyrosine gate. Other examples of good inhibitors have used aromatic rings (e.g. **67**, **68**). Thus, alkyl and aryl mannopyranosides can induce increased dynamics in the tyrosine gate.^{64,62}

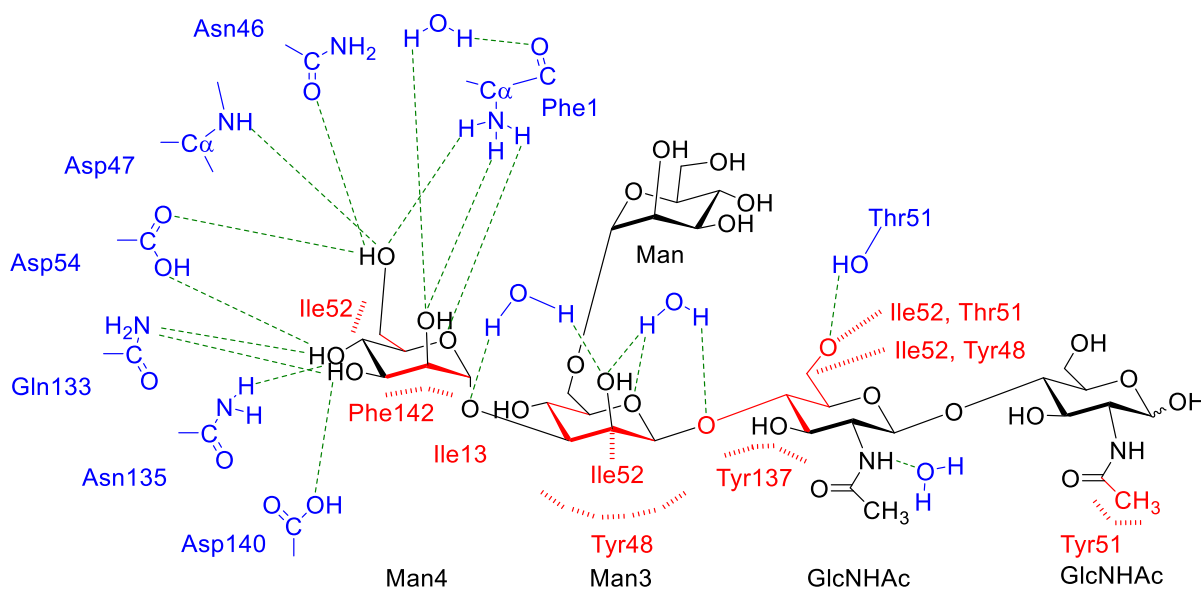

Figure 16: The interactions of FimH with the core pentasaccharide ligand.⁴⁷ A network of hydrogen bonds (green dashed lines) surround Man. Water molecules form hydrogen bonds along on side of oligomannose. The residues of the tyrosine gate, Tyr48, Ile52 and Tyr137, interact via aromatic stacking and hydrophobic contacts (all marked in red).

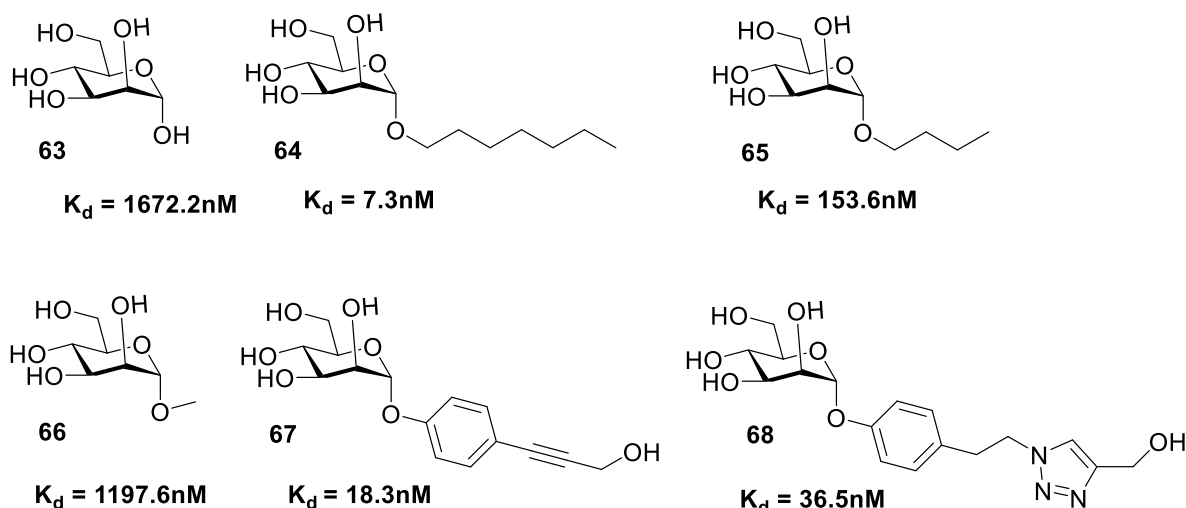

Figure 17: Monovalent mannopyranose derivatives as FimH inhibitors, K_d values provided as reported.⁶¹ No errors bars have been reported in this publication.

2.5 Comparison Between C-glycosides and O-glycosides

Carbon-linked glycosyl derivatives, so called *C*-glycosides, have also been found to be high affinity ligands for FimH and block the ability of UPECs to attach to the lower urinary tract by the FimH adhesion. For example, *C*-glycoside **70** has been reported having a K_d of 31nM whereas the corresponding *O*-linked analogue **69** has a K_d of 62 nM.²³ *C*-glycoside **72** showed to be active orally in reducing the levels of bacteria in the gut of mice by comparison to untreated mice. Furthermore, compound **72** showed low cytotoxicity and good water solubility at the concentration of 1 mM (**Figure 18**).⁶⁵

Other studies showed that *C*-linked mannosides possess a similar affinity compared to their *O*-mannoside analogues e.g. *C*-glycoside **74** ($K_d = 22$ nM) versus *O*-glycoside **73** ($K_d = 14$ nM), or *C*-glycoside **77** ($K_d = 6.9$ nM) versus *O*-glycoside **76** ($K_d = 4.3$) (**Figure 18**).⁶⁶

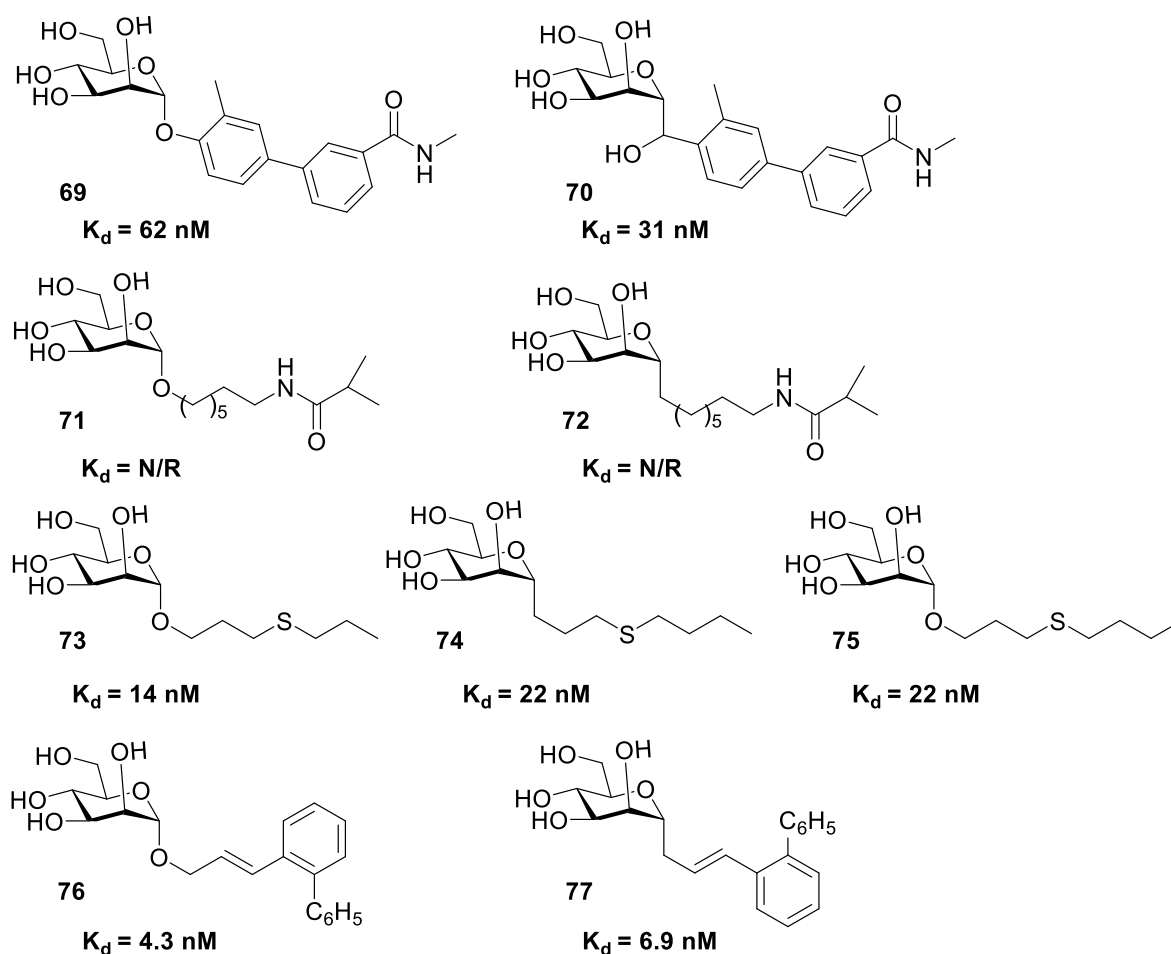

Figure 18: C-mannopyranose derivatives show high affinity towards FimH similar to O-mannopyranose. (N/R) is not reported.^{23,65,66}

Analogue C-glycosides inhibitors have been designed to reach the bladder safely without premature cleavage because there are no metabolic processes for these structures.⁶⁷ These molecules are soluble in aqueous systems and have low toxicity.⁶⁵ Therefore, the stability of these pseudoglycosides makes this class of compounds interesting, particularly for the design of inhibitors, therapeutics, and glycomimetics.⁶⁸

2.6 Multivalent Glycomimetics

The individual binding of carbohydrate ligands and protein receptors is usually very weak and in the micromolar range. In comparison, modern drugs inhibiting proteins usually exhibit K_d values in the nanomolar range.

The first synthetic monovalent compound to inhibit binding of FimH of *E. coli* was methyl α -D-mannoside **66** with a reported K_d of about $1.2 \mu\text{mol}$ (**Figure 17**).⁶⁹

Multivalent presentation of carbohydrate-based ligands has been seen as an option to increase the overall strength of interactions between a ligand and its receptor.⁷⁰ Since multivalent glycomimetics are often required to attain biological attachment strength and compound **78** “is currently one of the most promising antiadhesive drugs for the treatment of urinary tract infections under development” (**Figure 19**).⁷¹ Evaluation of compound **78** and **79** demonstrated that they are effective in terms of the inhibition of binding of *E. coli* to erythrocytes.

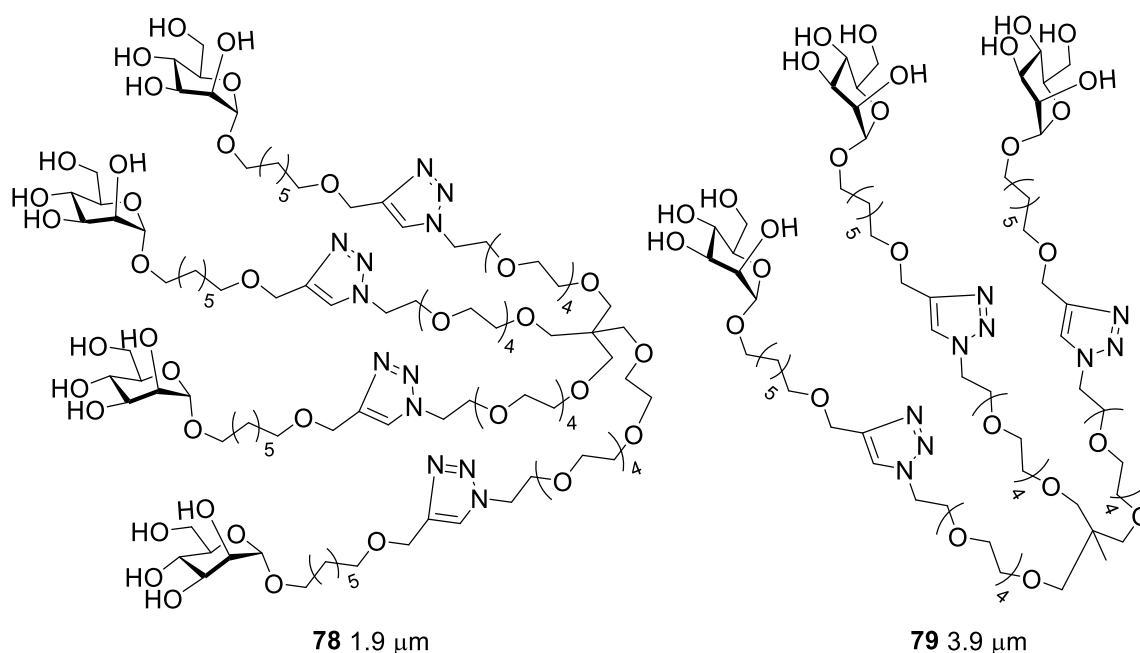

Figure 19: Examples of multivalent glycomimetic have been designed as inhibitors.⁷¹ These inhibitors are used for the design of multimeric glyco-clusters to inhibit the binding of *E.coli* and showing good inhibition (tetra-valent inhibitor **78**: $K_d = 1.9 \mu\text{m}$ and **79** K_d of $3.9 \mu\text{m}$ for the trivalent ligand.⁷² The tetra-valent compound **78** is eightfold better than monovalent analogue $K_d = 15.6 \mu\text{m}$ (not showed).

Multivalent interactions increase effectively affinity and adhesive forces to cell surfaces of the host. However, multivalency is generally defined by multiple non-covalent interactions between carbohydrate ligands and receptors for adhesion. Pathogenic *E.coli* bacteria are good example for this kind of interactions because they use fimbriae assisted attachment of their FimH lectin to α -D-mannopyranoside presenting tissues (umbrella cells). These fimbriae bind to the uroplakin presented on the umbrella cells in the bladder, and the large number of interactions can make the total binding stronger than the sum of the individual binding events. This

effect is called multivalency, which depends on many factors e.g. the type of interactions, spatial arrangement and size of ligands.^{73,74} Multivalency is important for several biological processes such as protein-ligand interactions⁷⁰ and especially in the relationship between bacteria and their host.⁷⁵

CHAPTER 3

Aim of the project

The uropathogenic *E.coli* (UPEC) is the major cause of urinary tract infections (UTIs). The binding through *E. coli*'s FimH adhesin is a crucial step in the infection. UPEC's FimH adhesin is binding to D-mannosides exhibited in the bladder lining.

The target of this work is the development of the synthetic route and synthesis of α -C-D-mannoside **I**, α -C-L-rhamnoside **II**, α -C-D-rhamnoside **III**. In order to achieve multivalency via conjugation to carriers as gold nanoparticles (GNPs) an additional suitable functionalised linker will have to be introduced. Several conjugation linkers will have to be evaluated. This will lead to the synthesis of conjugation linker 2-(2-(prop-2-ynoxy)ethoxy)ethanthioacetate **171** and the extended analogues **IV**, **V**, and **VI**. While compounds **II**, **III** and the analogues extended conjugates **V** and **VI** are intended as reference compounds. Compounds **III** and **VI** as possible weak binders and **II** and **V** as non-binders, compounds **I** and **V** are designed as prototypes for the development of novel therapeutics and as sensing probes for UPECs in urine. Thus, these compounds are designed as analogues to heptyl- α -O-D-mannoside **VII** which has been found to inhibit the binding of *E. coli* to the bladder lining with high affinity (**Figure 3-A**).⁶⁴

The synthesis starts all with the introduction of the pseudo anomeric C-allyl group using known procedures from an appropriate monosaccharide as intermediate. However, a chain of 8 carbon atoms has been proposed to be effective for good binding to FimH. Therefore, the key step for the preparation of the target compounds is connecting the remaining linker atoms including an additional functional group that will allow for further conjugation, e.g. in order to achieve multivalent analogous, to the 3-(1'-deoxyglycopyranos-1'-yl)-1-propenes. Both the Wittig reaction and the CM will be evaluated for this chain extension step. The final compounds **I**, **II**, and **III** will be characterized by ¹H NMR and ¹³C NMR spectroscopy. In order to achieve multivalent presentation of the ligands, additional bifunctional linker will be synthesised and conjugated to the azido derivatives **I**, **II**, and **III**. Attempts will be made to ligate those derivatives to a carrier.

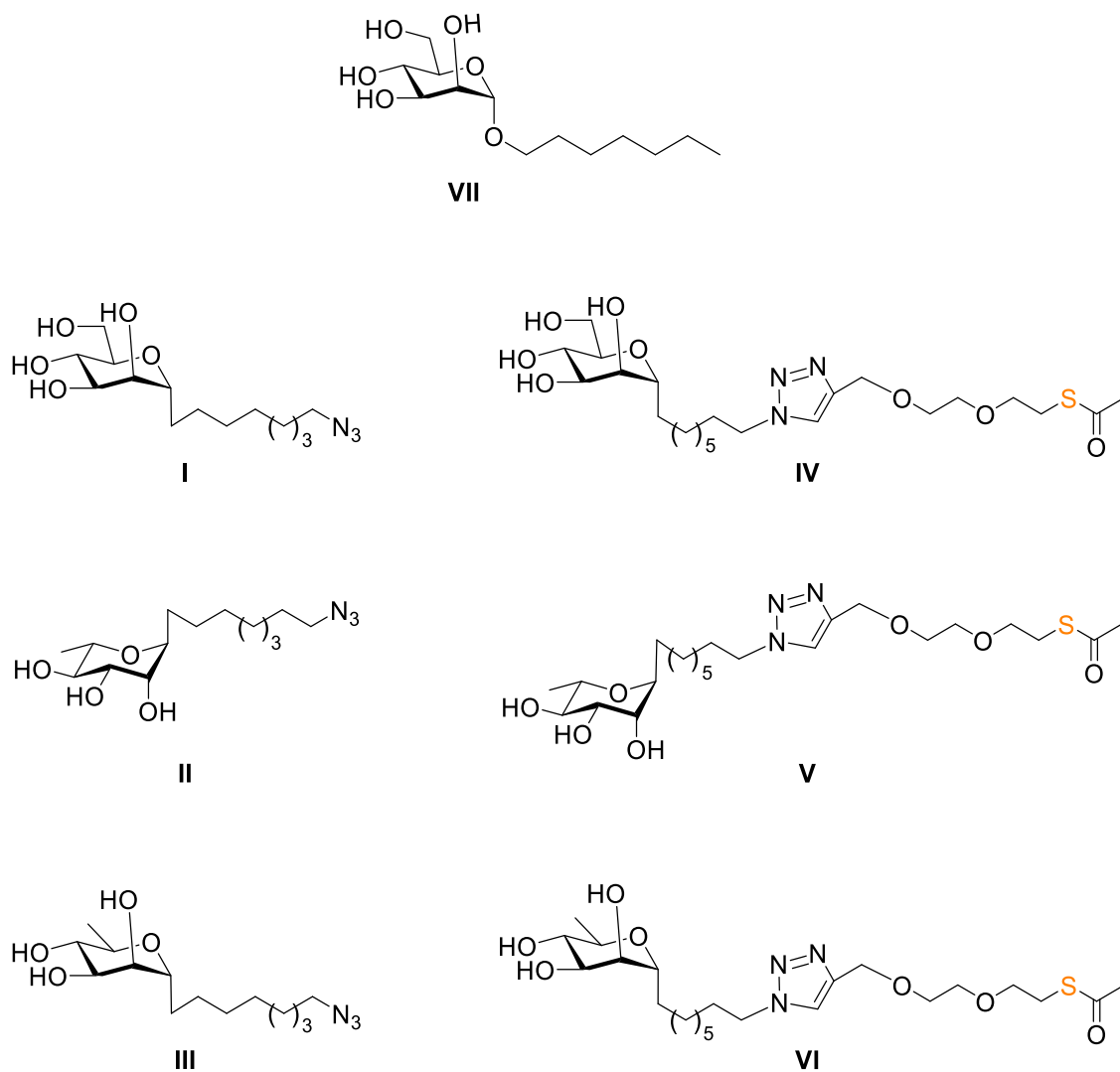

Figure 3-A: The final compounds. I (D-Man.), II (L-Rha.) and III (D-Rha.).

CHAPTER 4

RESULTS AND DISCUSSIONS – PART 1

Synthesis of the pseudo monosaccharide epitopes

4.1. Synthesis Design - Overview

While methyl- α -D-mannoside **66** and butyl- α -D-mannoside **65** have been known for a long time as inhibitors for FimH, the high affinity ligand heptyl- α -D-mannoside **64** has been found more recently.⁷² All compounds are *O*-glycosides and have been prepared by glycosylation chemistry with suitable alcohols according to standard procedures. The preparation of 1-deoxy glycosyl derivatives requires different methodologies compared to *O*-glycosides.

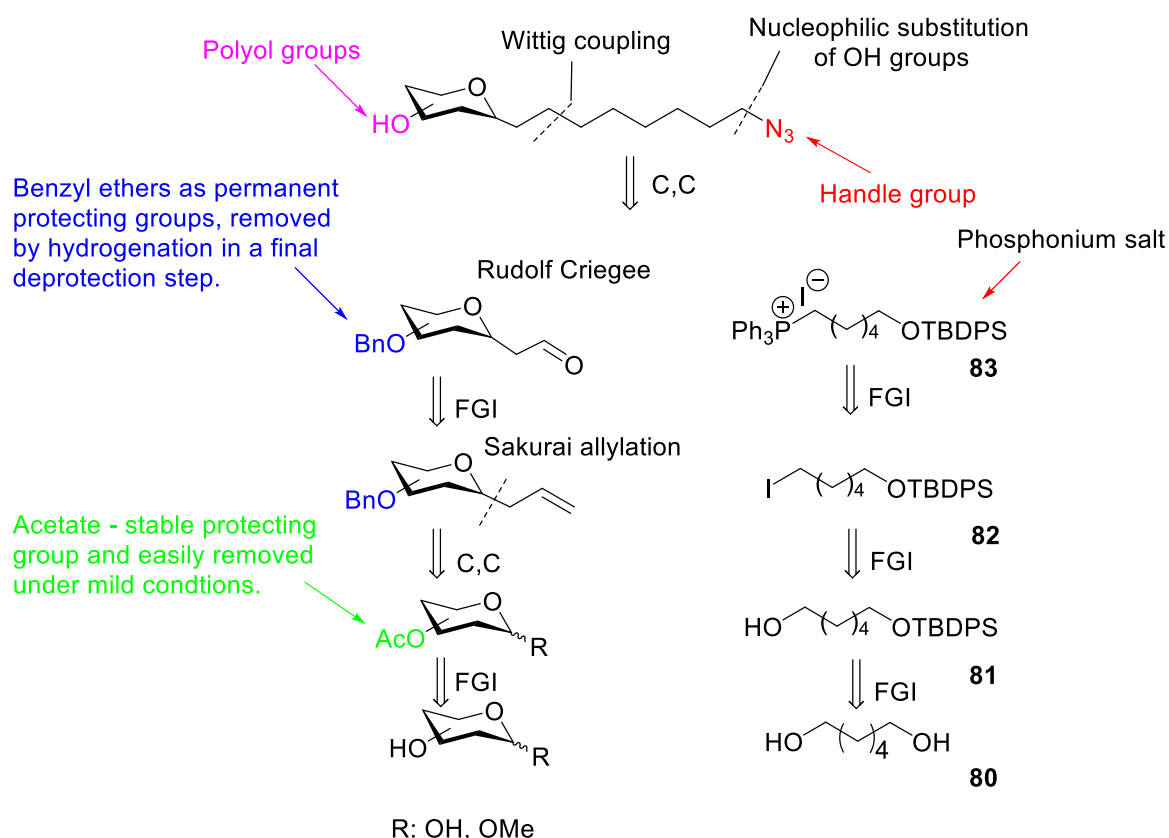

Scheme 16: A retrosynthetic pathway for the sugar target molecules. This strategy uses a sugar derivative with a phosphonium salt in a Wittig coupling.

During this work, both routes via the Wittig reaction and via the cross-metathesis (CM) reaction have been explored. Previous work in the group had trialed the Wittig route⁷⁶ but initial experiments using the corresponding L-rhamnose derivative **87** were low yielding and not exceeding 25% yield in the Wittig step (**Scheme 17**).

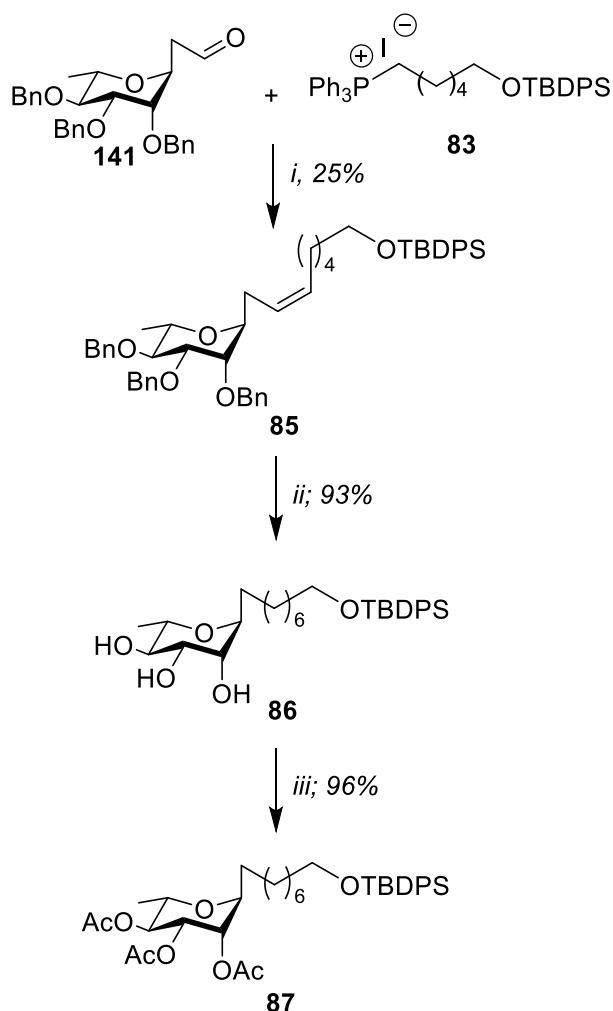

Scheme 17: *i.* LiHMDS, THF, DMPU, -78 °C; *ii.* Pd(OH)₂/C, EtOAc/ MeOH(1:1); *iii.* Ac₂O, pyridine.

Thus, our focus shifted towards the CM route. The pathway via the CM was evaluated for both the L-rhamnose derivative **130**, the D-mannose derivative **133** and the D-rhamnose derivative **136**. Unfortunately, it was not possible to achieve analytical pure samples via this pathway and all three compounds were eventually prepared via the Wittig route in satisfying yields and analytical pure qualities, and details about this approach will be discussed in section **4.6**.

4.2. Retrosynthetic Pathway Using A CM Reaction

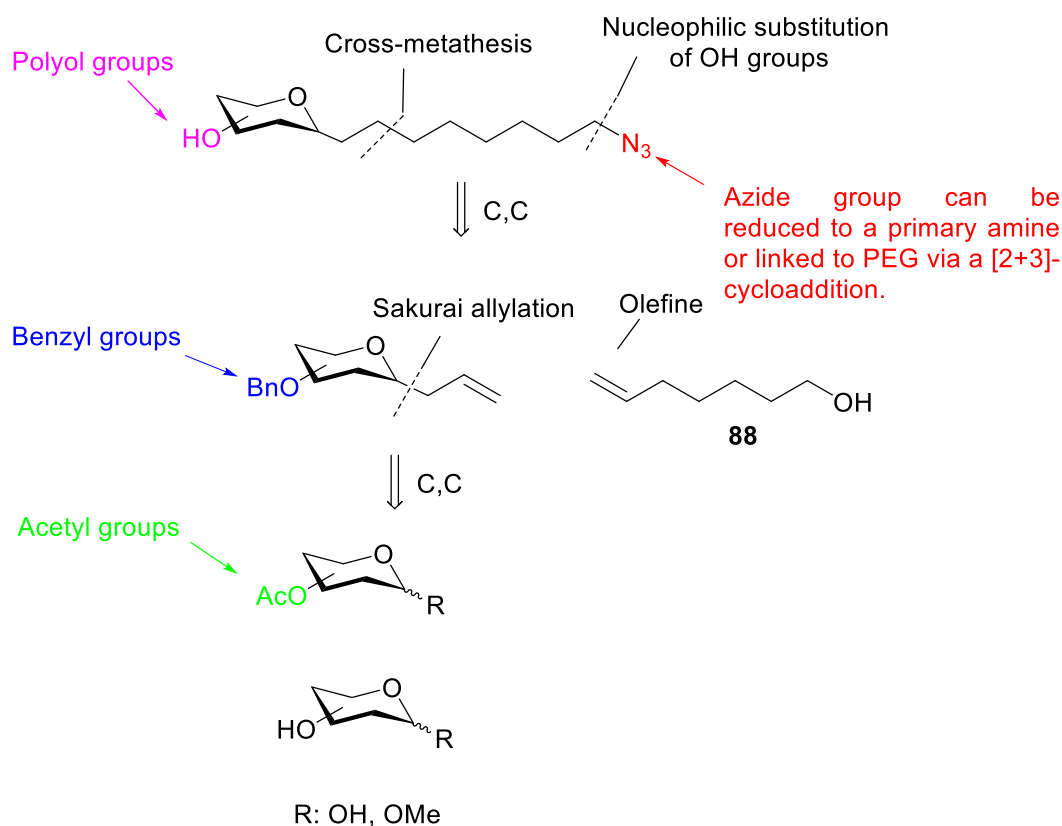

Scheme 18: A retrosynthetic pathway using a CM reaction for the sugar target molecules which requires overall fewer steps because the required linker **88** is commercially available.

The structures of synthesis required for the target molecules includes allyl sugar equipped with permanent protecting groups and allyl group for possible coupling reaction to produce a backbone of the target. This target could then be deprotected to remove its benzyl protecting groups by hydrogenation in final steps to obtain polyols sugar (**Scheme 18**).

The key steps in the Wittig pathway were the syntheses of the suitable protected sugar aldehydes and the linker as its Wittig salts. This was followed by the introduction of the azide group in order to have a handle for further conjugation. Global deprotection by hydrogenation produced the target azides **130**, **133**, and **136**. Some material was further conjugated to a diethylene glycol-based linker in order to achieve multivalent presentation after conjugation to GNPs.

4.3 The Synthesis of α -C-L/D-glycosides **92**, **11**, **103**

Due to ongoing work on rhamnosides – and thus expertise – in the research group, α -C-L-rhamnoside **130** was selected as first target compound to be synthesised from L-rhamnose **89** (**Figure 20**). While L-rhamnose shares the 2-axial hydroxy group with mannose, it lacks the hydroxy group in the 6-position and represents overall a mirror image of 6-deoxy D-mannose. Thus, binding to FimH is expected to be possibly low, and as such this compound should be useful as a negative reference. The synthesis started from cheap and commercially available L-rhamnose and was primarily intended as model for investigating the synthetic route for both D-mannose **133** and D-rhamnose **136** derivatives.

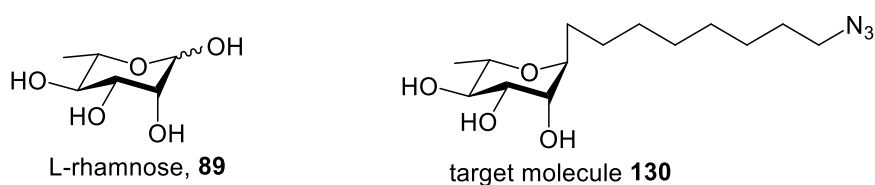

Figure 20: L-Rhamnose **89** and the target molecule **130**

Analysis of synthesised intermediates and target products was done by a range of analytical techniques. However, NMR analysis was employed for a rapid confirmation of the structural identity of the intermediates.

In this work many C-glycosides are prepared. C-glycosides differ significantly from O-glycosides in the NMR spectrum (**Figure 21**) because of the loss of the anomeric centre. A doublet around 4-6 ppm, generally with a lower chemical shift for the β -anomer, is usually clearly visible in the ^1H NMR and around 95-105 ppm in the ^{13}C NMR for O-glycosides. For the C-glycosides, the pseudo anomeric carbon is found in the ^{13}C NMR in the same shift range as all the ring carbons, generally between 70-80 ppm, and the pseudo anomeric proton is found between 3-4 ppm either as triplet or doublet or a multiplet.

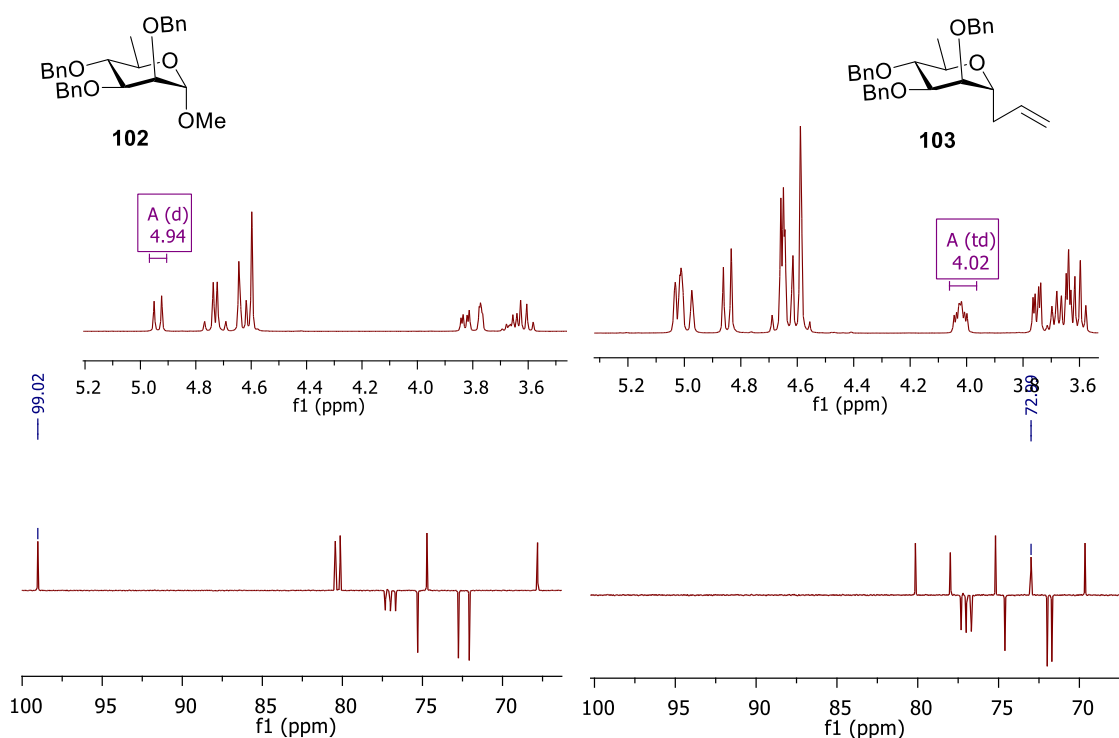

Figure 21: ^1H NMR and ^{13}C NMR spectra for *O*-glycoside **102** and *C*-glycoside **103**.

4.3.1 Synthesis of 1'-Deoxy-L-rhamnosyl-1-propene Intermediate **92**

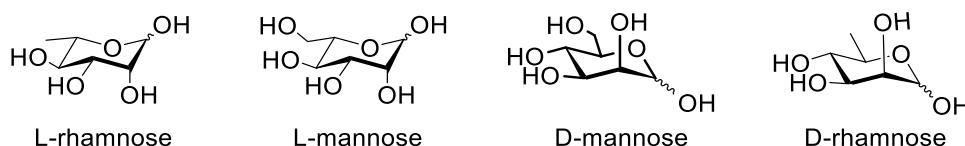
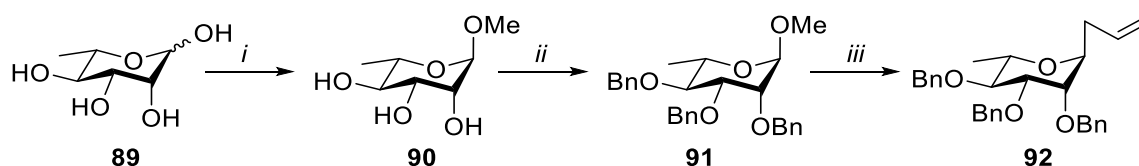

Figure 22: L-rhamnose, the 6-deoxy form of L-mannose, D-mannose and D-rhamnose.

The synthesis started with the preparation of the known compound 3-(1'-deoxy-2',3',4'-tri-*O*-benzyl- α -L-rhamnopyranos-1'-yl)-1-propene **92** following literature procedures (**Scheme 19**).^{77,78,79}



Scheme 19: Synthetic route from L-rhamnose to produce the corresponding *C*-glycoside in a yield of 25 % over 3 steps. *i.* CH_3OH , Amberlite[®] IR120-H, reflux, overnight, 85%; *ii.* BnBr , NaH , DMF , 1 h, 56%; *iii.* allyltrimethylsilane, $\text{BF}_3\cdot\text{Et}_2\text{O}$, TMSOTf , CH_3CN , 4 h, 52%.

In the first step L-rhamnose **89**, a naturally occurring deoxy sugar that can also be seen as 6-deoxy-L-mannose, was converted into methyl L-rhamnoside **90**. This step was performed in CH₃OH in the presence of ion exchange resin (Amberlite® IR120-H) under reflux giving **90** in a good yield (85%). The next step was to introduce the benzyl ethers as permanent protecting groups using benzyl bromide and sodium hydride in DMF giving **91** in a 56% yield. Hosomi-Sakurai reaction conditions,⁷⁹ were used to introduce the propenyl group giving the pseudo C-glycoside **92** in 52% yield as pure pseudo α -anomer according to NMR (**Scheme 19**).

Although this route is short, the total yield over three steps is only 25%. Thus, an alternative pathway was explored. This route, described below, turned out to be more efficient in terms of the total yield, giving C-glycoside **92** in a yield of 53% over 4 steps.

The alternative route to synthesize 3-(1'-deoxy-2',3',4'-tri-*O*-benzyl- α -L-rhamnopyranos-1'-yl)-1-propene **92** was done following literature procedures (**Scheme 20**).

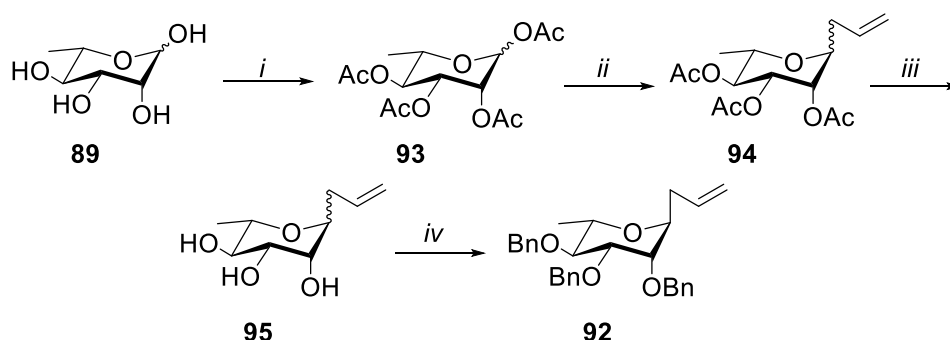

Scheme 20: An efficient synthetic route from L-rhamnose to produce the corresponding C-glycoside in a yield of 53 % over 4 steps. i. Ac₂O, pyridine, DMAP (rt, 3h), 96%; ii. allyltrimethylsilane, BF₃·Et₂O, TMSOTf, CH₃CN, 79%; iii. NaOMe, MeOH (rt), 98%; iv. BnBr, NaH, DMF, 71%.

L-rhamnose **89** was peracetylated to yield the *O*-acetyl protected L-rhamnopyranoside **93**. This was carried out using acetic anhydride (Ac₂O) and sodium acetate (NaOAc) giving a colourless oil in yield 60%.⁸⁰ Following an alternative approach, the acetylation was achieved with pyridine and DMAP in acetic anhydride to give a yield of 96% (anomeric mixture, 83:17 according to NMR) after 3 h.⁸¹ The obtained tetra-acetate **93** was converted into C-glycoside **94** by substituting the anomeric acetate with an allyl group under Hosomi-Sakurai reaction conditions⁷⁹. The introduction of this allylic group into the pseudo anomeric position was achieved

in high stereoselectivity using allyltrimethylsilane, $\text{BF}_3 \cdot \text{Et}_2\text{O}$ and TMSOTf, providing *C*-glycoside **94** a yellow oil in 79% (pseudo α /pseudo β 90:10). It was not possible to separate the anomers at this stage. The acetate groups were removed under transesterification conditions (Zemplén conditions)⁸² using NaOMe and MeOH giving triol **95** in 98% as a mixture (93:7) of pseudo anomers (**Scheme 20**). To introduce the benzyl ether protecting groups, benzyl bromide and sodium hydride was used to give 2,3,4-tri-*O*-benzyl- α -L-rhamnopyranoside **92** in a yield of 71%.⁸³ However, it was found that separation of the pseudo anomers for all examined monosaccharides was easier using the benzylated derivatives. Also, the subsequent oxidation to the aldehyde gave generally cleaner material than using the acetylated derivatives.

4.3.2. Synthesis of 1'-Deoxy-D-mannosyl-1-propene Intermediate **11**

Due to the satisfying results for the synthesis of the 1'-deoxy L-rhamnosyl-1-propene intermediate **92**, the procedures were adapted for the preparation of the known 1'-deoxy D-mannosyl-1-propene intermediate **11** (**Scheme 21**).⁸⁴

D-mannose **63** was treated with acetic anhydride in pyridine to give 1,2,3,4,6-penta-*O*-acetyl-D-mannopyranose **27** in a near quantitative 97% yield. The pentaacetate **27** was then converted into 1'-deoxy *C*-glycoside **96** under Hosomi-Sakurai conditions in 95% yield. A transesterification under Zemplén conditions using NaOMe and MeOH was carried out to remove the acetyl protecting groups giving triol **97** after 1 h in 91% as a mixture of pseudo anomers (89:11). Benzyl groups were introduced using benzyl bromide and sodium hydride giving **11** in 81% yield (**Scheme 21**). Separation of the pseudo anomers required an additional chromatographic step (Tol/DE 99:1 \rightarrow 95:5), $R_f = 0.11$ (PE/EtOAc 9:1) and provided the pseudo anomerically pure intermediate **11- α** in 90% yield.

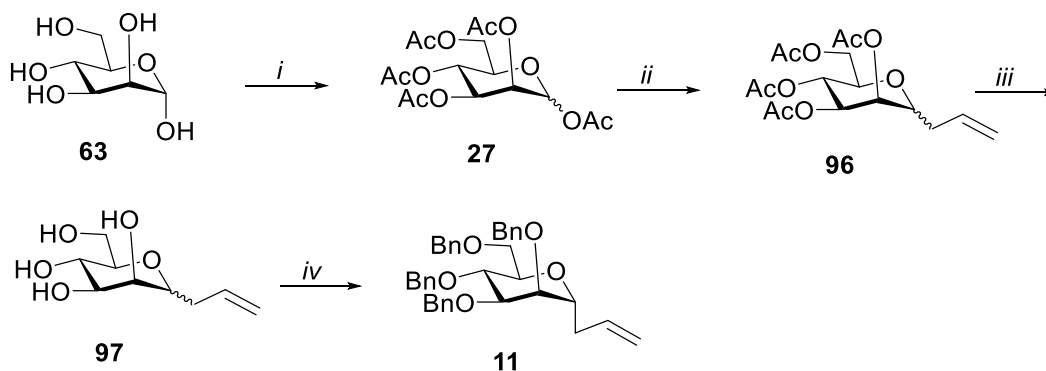

Scheme 21: i. Ac₂O, pyridine, DMAP (rt, 2h), 97%; ii. allyltrimethylsilane, BF₃·Et₂O, TMSOTf, CH₃CN, 95%; iii. NaOMe, MeOH (rt), 91%; iv. BnBr, NaH, DMF, 81%.

4.3.3. Synthesis of 1'-Deoxy-D-rhamnosyl-1-propene Intermediate 103

The third target was the novel compound D-rhamnoside **103** (Scheme 22) designed for this study. However, compound **103** may also serve as an interesting building block for carbohydrate chemistry and other lectin studies. To obtain compound **103**, α-D-methylmannoside **66** was used as starting material following published procedures until compound **102**.⁸⁵ Thus, the primary alcohol of methyl mannoside **66** was protected with *tert*-butyldiphenylsilyl chloride (TBDPSCl) in DMF to give *tert*-butyldiphenylsilyl ether **98** in a yield of 83%, before introduction of benzyl ethers with benzyl bromide and sodium hydride giving **99** (50%).

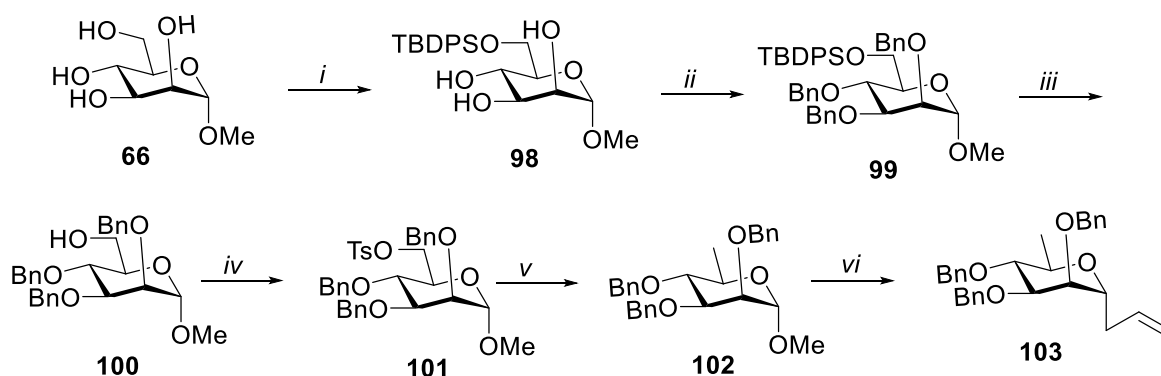

Scheme 22: i. TBDPSCl, imidazole, DMF, (rt, overnight), 83%; ii. BnBr, NaH, DMF, 50%; iii. TBAF, THF, 75%; iv. TsCl, DMAP, pyridine, DCM, 85%; v. LAH, ether, 62%; vi. allyltrimethylsilane, TMSOTf, CH₃CN, 86%.

The moderate yield was due to partial loss of the silyl ether group leading to the tetrabenzylated methyl mannoside **10** as major side product. This was clearly visible while monitoring the

reaction by TLC, where a second spot corresponding to the R_f value associated with compound **10** appeared. The formation of **10** was then supported by ^1H NMR analysis. Proton NMR confirmed the disappearance of the signal expected for the *tert*-butyl group integrating to 9 H at 0.97 ppm for compound **99**, and the appearance of an additional benzylic group. Also, only 20 protons corresponding to the phenyl groups were seen in the proton NMR for compound **10** while 25 protons of aromatic system were required for compound **99**.

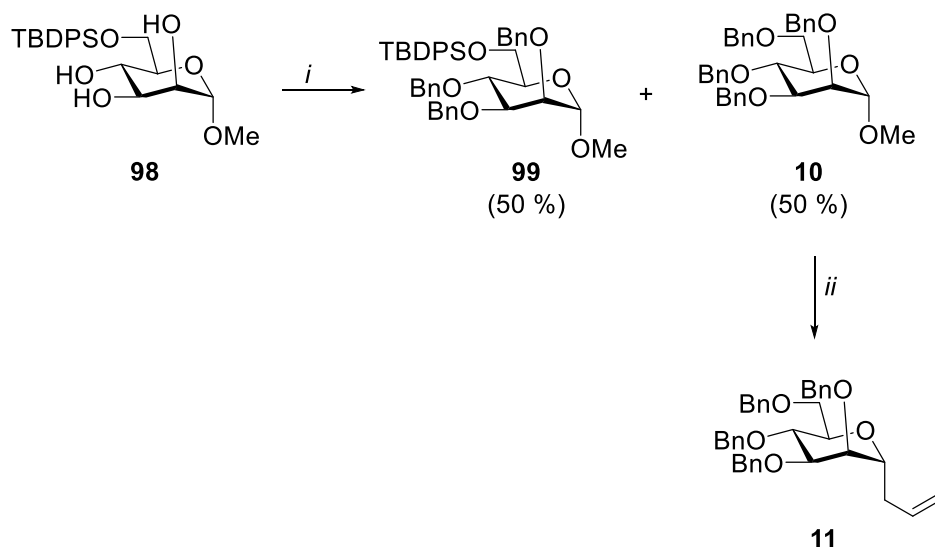

Scheme 23: *i.* BnBr, NaH, DMF, 50% and side product **10** 50%; *ii.* allyltrimethylsilane, TMSOTf, CH₃CN, 70%.

However, this material was isolated and converted into compound **11** (**Scheme 23**). The silyl ether of **99** was cleaved using tetrabutylammonium fluoride (Bu₄NF) to give **10** in a yield 75%. In order to be able to reduce the primary hydroxyl group to a methyl group a better leaving group had to be introduced. Initially, the primary hydroxyl group was changed for the iodine group as leaving group at the 6-position. However, this step gave a low yield of 20% and for this conversion and iodination was abandoned. Instead the introduction of a tosyl leaving group at 6-position was attempted to give **101** using tosyl chloride (TsCl) in pyridine in 85% yield which is not too far off the reported 96% yield. Subsequent reduction of the tosyl group has been reported using lithium triethylborohydride (LiEt₃BH) in THF to get to compound **102** as an intermediate. However, no yield had been reported because the intermediate was directly converted to methyl 6-deoxy- α -D-rhamnoside.⁸⁵

The reduction to the D-rhamnoside giving compound **102** in 62% yield was carried out using lithium aluminium hydride (LiAlH₄) in diethylether instead. LiAlH₄ was used as a reducing

agent instead of LiEt_3BH due to being easier to handle and because it was available in the lab. NMR analysis confirmed the disappearance of the methyl group of the 4-toluenesulfonyl group at 2.35 ppm and the presence of only three aromatic systems. Also, the significant doublet for the methyl group in the 6-position at 1.29 ppm for compound **102** appeared in the proton NMR spectrum.

Another step was required to obtain the pseudo *C*-glycoside of D-rhamnoside **103** by reacting methyl- α -D-rhamnopyranoside **102** with allyltrimethylsilane and TMSOTf in acetonitrile. Intermediate **103** was obtained in a 86% yield and the structure confirmed by NMR analysis (Scheme 22).

An alternative and shorter route to synthesise D-rhamnoside starts also with methyl mannoside **66**. Following a literature procedure,⁸⁶ the primary hydroxyl group was changed for the iodine group as leaving group at the 6-position using iodine, triphenylphosphine (PPh_3) and imidazole in THF. Unfortunately, this step gave a disappointing yield of 23% for compound **105**. Thus, instead a tosyl group was introduced regioselectively to give **106** in a better yield 75% yield. Due to the high polarity of **106**, an aqueous work-up had to be omitted. Instead, co-evaporation with toluene (3 \times) followed by chromatography gave **106** in an acceptable purity as confirmed by ^1H NMR, showing the methyl group of the tosyl group at 2.45 ppm and the protons of the phenyl group at 7.81 and 7.43 ppm integrating to 4Hs. Compound **106** was then reduced to **107** using LiAlH_4 , giving unprotected D-rhamnose in 94% yield. Since compound **107** is still rather polar, the solvent for the reaction had to be selected with care. Polar solvents as methanol, ethanol or even water had to be excluded due to the violent reaction of LiAlH_4 with any of those. However, less polar solvents as THF and diethyl ether are commonly used with these reduction conditions. However, a publication reported the reduction of benzyl 6-*O*-tosyl- α -D-mannopyranoside to benzyl 6-*O*- α -D-rhamnopyranoside using LiAlH_4 in THF.⁸⁷

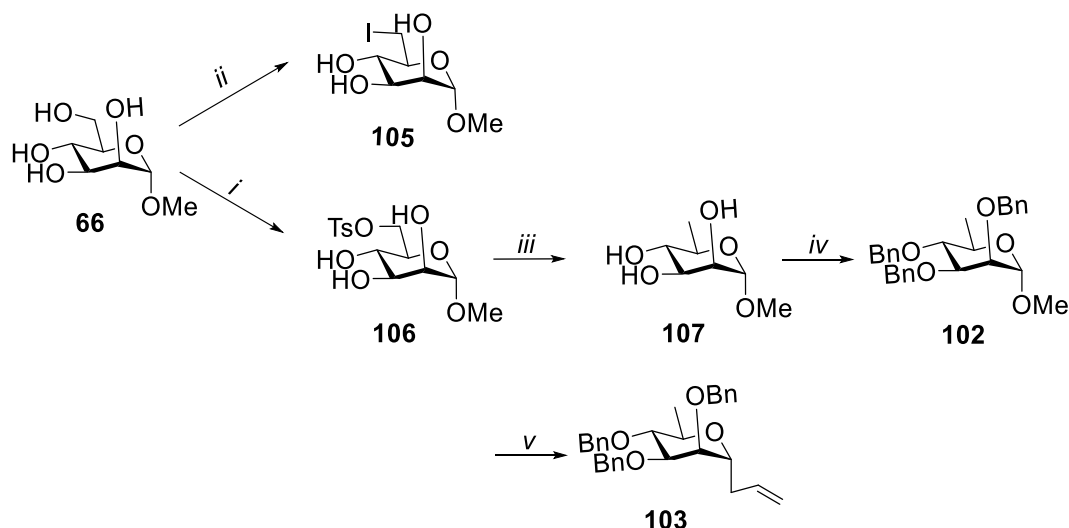

Scheme 24: *i.* TsCl, DMAP, pyridine, 75%; *ii.* I₂, PPh₃, imidazole, THF, 23%; *iii.* LAH, THF, 94%.
iv. BnBr, NaH, DMF, 79%; *v.* allyltrimethylsilane, TMSOTf, CH₃CN, 80%.

Thus, compound **106** was dissolved in THF and then added drop-wise to a slurry of LiAlH₄ at 0°C. NMR analysis confirmed the presence of a doublet for the methyl group in the 6-position at 1.23 ppm in ¹H NMR and at 17.99 ppm in ¹³C NMR. The hydroxyl groups were benzylated giving **102** in yield of 79%. The anomeric position was then converted into the C-glycoside **103** giving the allylic group in good yield of 80% (**Scheme 24**).

While both routes start from methyl α -D-mannoside (**66**), the shorter route via the direct reduction of the tosyl group of the unprotected mannoside **106** followed by benzylation and then C-glycoside formation appeared to be favourable, with total yield 45% over 4 steps compared to the first described route via the temporary silyl ether protection with total yield of 14% over 6 steps where the major drawback is the partial loss of the silyl ether group in the alkylation step.

4.4 Summary

In summary, the intermediate of L-rhamnoside **92** was produced from commercially L-rhamnose in 4 steps with an overall yield of 53% (**Scheme 20**). This synthetic pathway was then applied to commercial D-mannose **63** to produce the required C-glycoside of D-mannoside **11** with an overall yield 68%. The novel C-glycoside of D-rhamnoside **103** was prepared from the commercially available methyl α -D-mannoside (**66**) via two pathways. The direct reduction of

the unprotected tosylate produce a higher total yield (45%) than the route via employing a temporary silyl ether protecting group (total yield 14%).

NMR analysis confirmed the formation of the *C*-glycosides (**Figure 23, 24**). In the ^1H NMR of the intermediates, the signals for the allylic group in **92**, **11** and **103** can be seen clearly as doublet of doublet of triplet (ddt) at 5.75-5.64 ppm (**Figure 23**) for the allylic proton (blue arrow 2, $\text{CH}=\text{CH}_2$), and at range 5.01-4.87 ppm as either a doublet of doublet (dd) or a multiplet (m) for the terminal methylene group (green arrow 1, $\text{CH}=\text{CH}_2$). Interestingly, signals for the saturated methylene group (red arrow 3, $\text{CH}_2-\text{CH}=\text{}$) are forming a doublet of triplet (dt) for one proton at 2.31 ppm and a multiplet for the other at 2.23-2.13 ppm both for the *C*-glycosides of the *L/D*-rhamnoses (**92** and **103**). For the *C*-glycoside of *D*-mannose (**11**) only a multiplet at 2.42-2.25 ppm integrating for two protons is found. In addition, the spectrum shows the doublets for the methyl group on the 6-position belonging to the rhamnose derivatives **92** and **103** at 1.34 ppm. The appearance of this indicative signal was convenient to confirm the success of the reduction of the tosylated *D*-mannose derivative **101** to *D*-rhamnose derivative **103** (**Figure 23**).

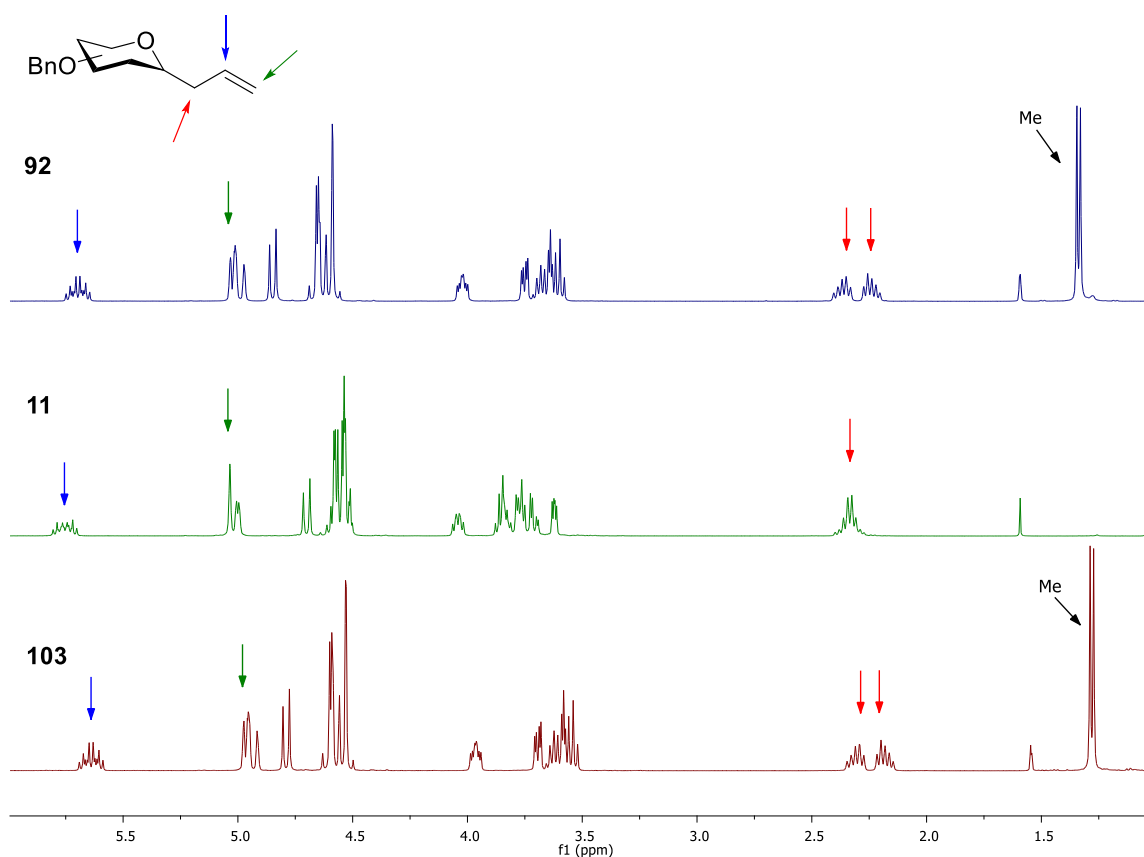

Figure 23: ^1H NMR spectra of **92**, **11** and **103**, the allyl group is seen for the anomeric centres. The interesting signal is the doublet of *D*-rhamnoside at 1.34 ppm (bottom).

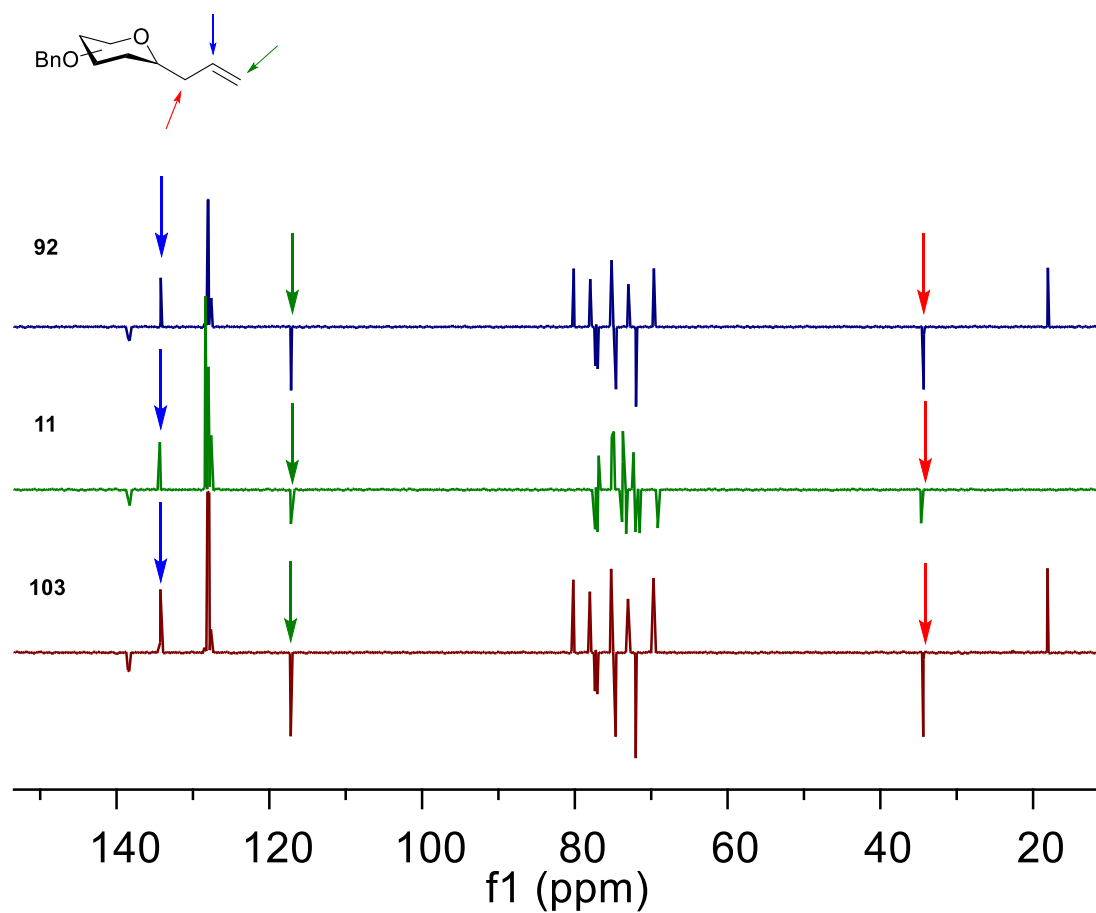

Figure 24: ^{13}C NMR spectra of **92**, **11** and **103**, the allyl group is seen for the anomeric centres. The signal of the methyl of D-rhamnoside at 18.1 ppm

4.5 The Synthesis of C-glycosides Using Cross-metathesis

4.5.1 Cross-metathesis (CM)

Cross-metathesis (CM) is a powerful tool for synthetic organic chemistry. The key of this methodology is the extension of a carbon chain by utilising two different substituted alkenes to construct a new carbon-carbon double bond and a larger molecule. Common side reactions are results of homodimer formation. Also, the formation of *E/Z* diastereomers is often observed.⁸⁸

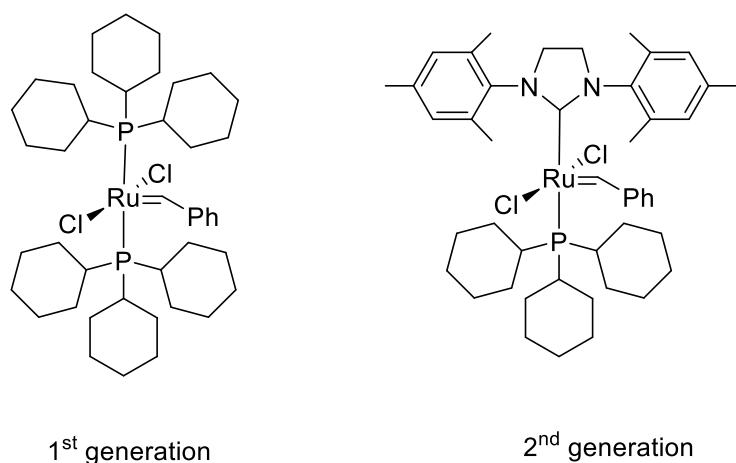

Figure 25: Grubbs 1st and 2nd generation catalysts.

Catalysts used for CM employ a transition metal based catalytic system, e.g. a N-heterocyclic ruthenium benzylidene unit for metal carbene-coordination.⁸⁹ Grubbs 1st and 2nd generation catalysts (**Figure 25**) are highly active and relatively stable which allow the cross-metathesis to proceed also in aqueous or buffer systems, and have thus acquired synthetic importance in domains such as biochemistry and biological chemistry. Olefin metathesis offers a shortcut for synthetic intermediates that in conventional organic synthesis would require several synthetic steps.^{90, 91}

The efficiency of cross metathesis reaction can be affected by the selectivity of the metallacyclobutane formation and the stability of the catalyst. Through the reaction, productive and unproductive olefin compounds are occurring. Due to cyclo-reversion (“retro-CM”) of a ruthenium methylidene intermediate, productive CM compounds will be generated from 1,2-disubstituted metallacyclobutane, while the coordination of the olefin with a catalyst leads to 1,3-disubstituted metallacyclobutane and therefore results unproductive CM reaction (**Figure 26**).⁹²

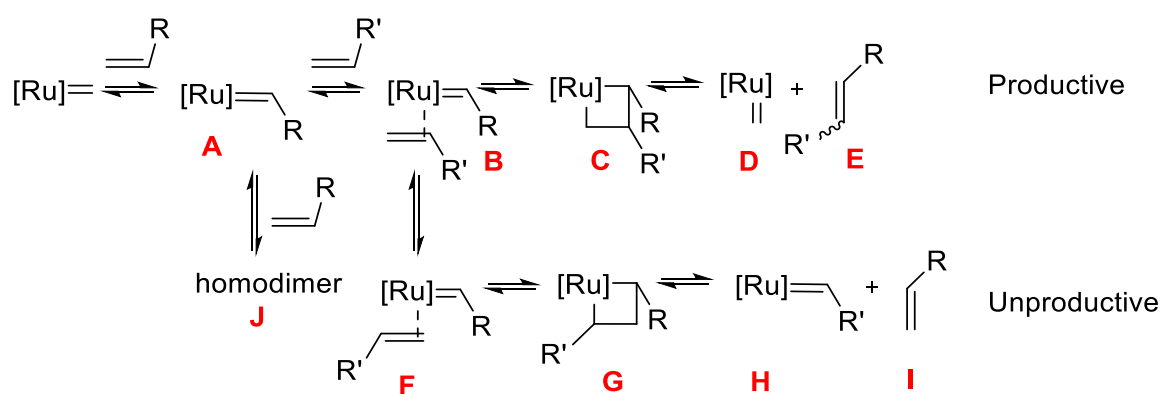
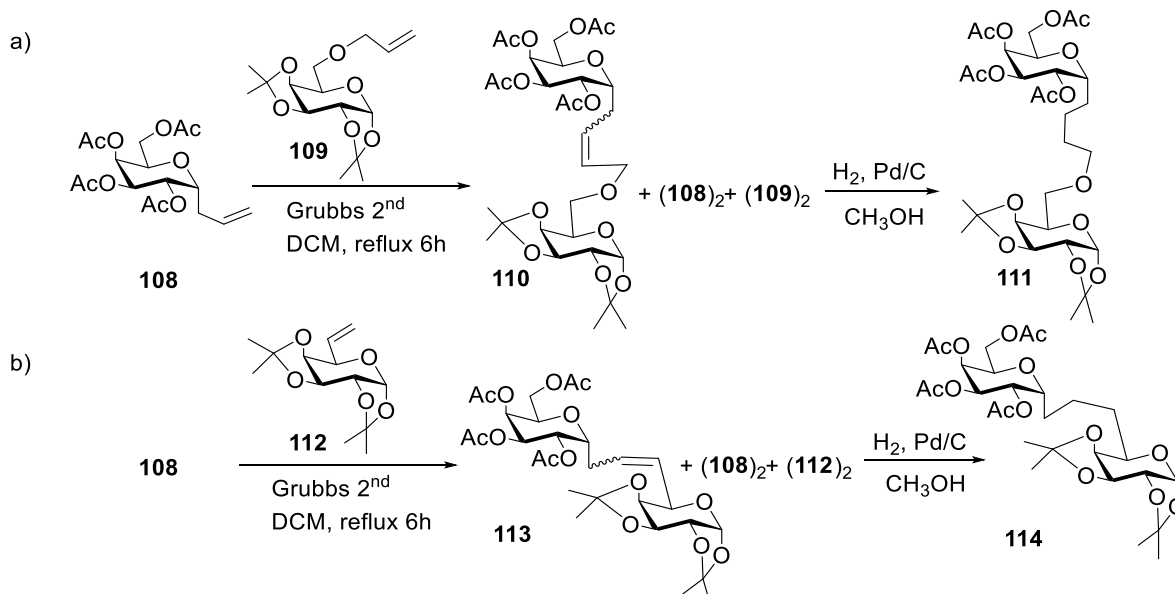

Figure 26: Pathways of the productive and unproductive olefin metathesis.⁹⁰

Roy and Sanjoy synthesised compound **108** using peracetylated D-galactopyranose with allyltrimethylsilane in the presence of $BF_3 \cdot OEt_2$ to give C-allyl- α -D-galactopyranose derivative **108** (Scheme 25).⁹³ The galactose derivative **108** and two equivalents of 6-O-allyl-1,2:3,4-di-O-isopropylidene- α -D-galactopyranoside **109** were reacted using Grubbs 2nd generation catalyst to synthesise **110**. In the same way, they also performed CM with two equivalents of 1,2:3,4-di-O-isopropylidene- α -D-galactopyranose **112** to give **113** in good yield. A disadvantage of this route is the formation of homodimers resulting from self-metathesis of the starting materials. This homodimer formation depends on the substrates and can substantially reduce the yield of the CM products. Also, mixtures of *E* and *Z* diastereoisomeric alkene are formed. However, as in this example, reduction using 10% Pd/C in methanol, under H_2 atmosphere at room temperature for 12 h gave quantitative yields of the uniformly saturated compounds **111** and **114**.⁹³



Scheme 25: Two examples using CM in carbohydrate chemistry yielding both the CM products and the homodimers. a) **110** (67 % cis/trans mixture) and homodimers $(108)_2(109)_2$ in overall 14%. b) **113** (89 % cis/trans mixture) and homodimers $(108)_2(112)_2$ in overall 6%.⁹³ (Scheme adapted from reference)

For the work presented in this thesis, *C*-glycosides were required as intermediates. The CM reactions were used to introduce the commercial linker hept-6-en-1-ol. The final products required a handle in order to perform reactions with other functionalised molecules, as scaffolds to enable multivalency or chromophores for detection. Thus, for the target *C*-glycoside molecules, an azido group was chosen as terminal group in order to have a handle that could either be directly coupled with an alkyne in a click reaction or converted to an amine group by hydrogenation for amide type based ligation.

While working on the synthesis of the target molecules, the synthesis of the acetylated 8-(1'-deoxy- α -D-mannopyranos-1'yl)-oct-1-azide **117** via CM was published.⁶⁵ The authors found that compound *C*-mannopyranose **72** is active orally in reducing of *E.coli* levels in the feces of mice much more than in untreated mice. An orally administered dose of this compound at 10 mg/kg completely removed *E.coli* from ileum and thus confirms the anti-adhesive concept. Also, reflecting the stability of *C*-glycoside derivatives against degradation by glycosidases, more of compound **72** was recovered in the faeces compared to its *O*-mannopyranoside analogue **71** (**Figure 18**).⁶⁵

A convergent approach, which is in general better for the atom economy, was employed by using a mesylated linker in the CM. However, using acetate protecting groups on the other

hand, added an additional synthetic step (**Scheme 26**).⁶⁵ In addition, from our experience, it is very difficult to obtain the pseudo-anomerically pure *C*-allyl mannose derivative **115**, and the pseudo anomeric ratio differs between saccharides. Thus, the main aim in this work was establishing a synthetic route that could be applied to a range of monosaccharides with good yields.

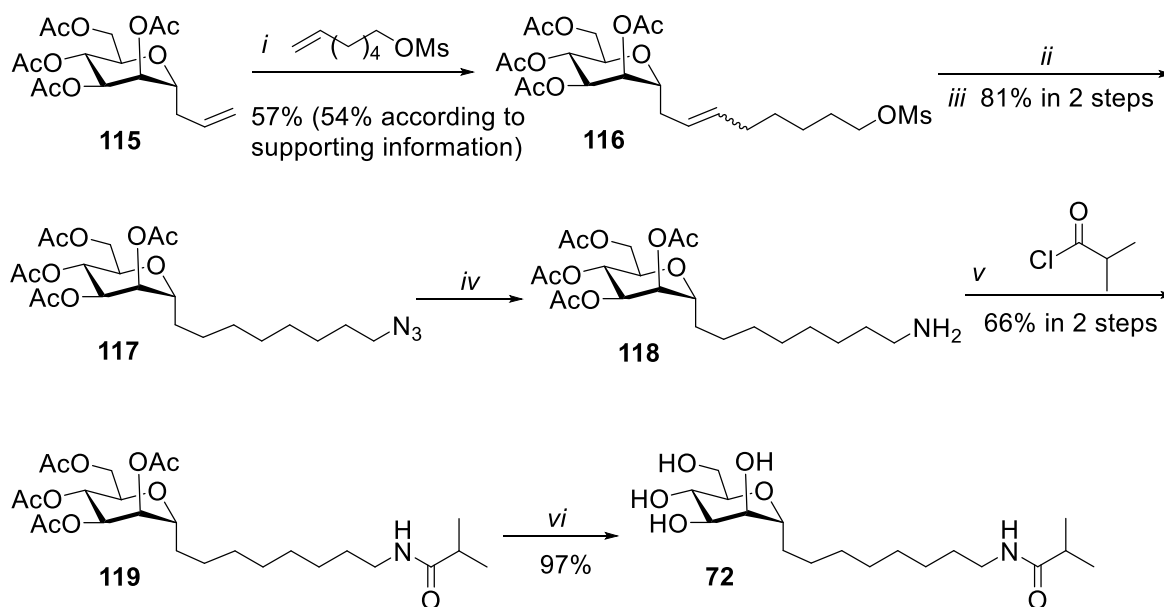

Scheme 26: Synthesis of the α -*C*-mannopyranoside. *i.* Grubbs 2nd, 10%, DCM, reflux, 8 h; *ii.* H₂, Pd/C, MeOH, 4 h; *iii.* NaN₃, DMF, 80°C, overnight; *iv.* H₂, Pd/C, MeOH, 10 h; *v.* isobutyric chloride, pyridine, DMAP, 5.h; *vi.* NaOMe, MeOH, 4 h, Amberlite IR120 (H).⁶⁵

4.5.2 The Synthesis of α -C-L/D-glycosides **125**, **126**, **127** Using CM

Due to the ease of the CM and the general reduction of synthesis steps, CM was the first choice to extend the chain of the intermediate compound **92**, **11** and **103** (Scheme 27).

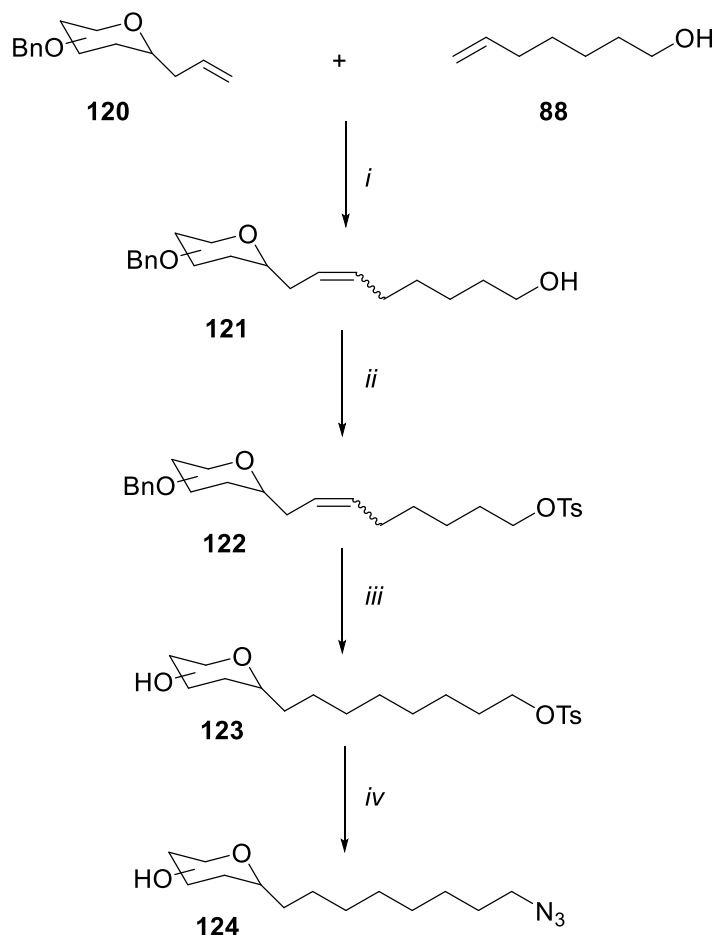

Scheme 27: Planned synthetic route towards the targets. *i*. Grubb's 2nd G., DCM, rt; *ii*. TsCl, pyridine; *iii*. Pd(OH)₂/C, EtOAc/ MeOH(1:1); *iv*. NaN₃, DMF, 130 °C.

To start, 50 mg scale test reactions were performed under CM reaction conditions⁹⁴ to optimise the yield of the desired coupling product **125** (Scheme 28). The table summarises the applied ratio of the heptenol **88** and the C-mannoside **18** starting materials in the CM reactions as well as the employed catalysts and the isolated yields of **125** after chromatographic purification (Table 1).

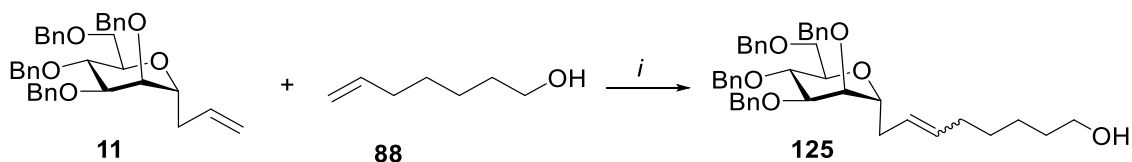

Scheme 28: *i.* Grubb's catalyst, DCM, rt, overnight, 32-73% yield.

Table 1: Ratio of the applied C-mannoside **11**, heptenol **88**, the catalyst used, and the obtained yields of CM product **125** in the CM test reactions (**Scheme 28**).

Entry	Ru-catalyst	ratio 11/88	125 , isolated yield %
1	1 st generation	1:5	32%
2	1 st generation	2:1	45%
3	2 nd generation	1:5	58%
4	2 nd generation	2:1	73%
5	2 nd generation	1:1	47%
6	2 nd generation	1:2	45%

Both *E/Z* diastereomers are usually formed in the CM but the geometry of the double bond is not important in this case because the double bond will be reduced in the next step.

Initially (entry 1), the 1st generation Grubb's catalyst was used with an excess of the linker **88** to reduce possible loss of yield of the more valuable mannose derivative **11** to homodimerization. While the yield was only moderate (32%) for the formation of **125**, increasing the ratio of **11** to **88** to 2:1 only marginally improved the yield for **125** (45%, entry 2). The first two experiments were repeated with the 2nd generation Grubb's catalyst giving in both cases substantially improved yields (entry 3: **11/88** 1:5, 58%, entry 4: **11/88** 2:1, 73%). However, reducing the excess of **11** decreased the yield (entry 5 and 6).

Based on these preliminary experiments, the reaction conditions for entry 4 were used for all subsequent CMs (**Scheme 29**). Thus, the CM of allyl compounds **11**, **92**, and **103** and 6-hepten-1-ol **88** were carried out to give olefins **125**, **126**, **127**. However, the yields in the up-scaled experiments were lower 57% (**125**), 53% (**126**) and 55% (**127**). In all cases, substantial formation of homodimers was observed both on TLC and ¹H NMR. This issue was not further

followed up because sufficient material was produced in order to perform the following reactions.

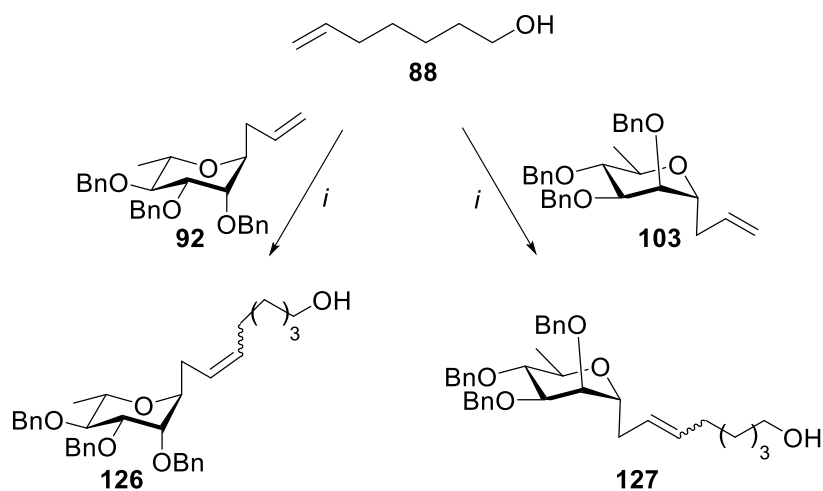

Scheme 29: *i.* Grubb's catalyst, DCM, rt, overnight, 53% -55% yields (L-rhamnose and D-rhamnose derivatives).

However, while the TLC showed only one spot after chromatography, the ^1H NMR spectrum of mannose derivative **125** revealed less clear signals overall and especially in the range (5.2-5.6 ppm) where signals for the double bond were expected for an *E/Z* isomeric mixture. The DEPTQ spectrum showed one set of signals derived from the ring carbons. At a closer inspection, small shoulders are visible for each signal. These signals could be linked to poor resolution but might indicate the presence of a second compound. However, the C-6 and C7, the two carbons forming the double bond, appear clearly as two sets of signals (C-6 133.3 and 132.1 ppm, C7 125.9 and 125.7 ppm) with one set substantially larger than the other. It was assumed that these signals might originate from the *E/Z* isomeric mixture combined with remaining small amounts of catalyst which could coordinate to the product forming a product-ruthenium complex, and additional signals (**Figure 27**). Since repeated chromatography did not produce any material of better purity, it was decided to continue with this material in the hope that after reduction of the double bond, the material would be uniform.

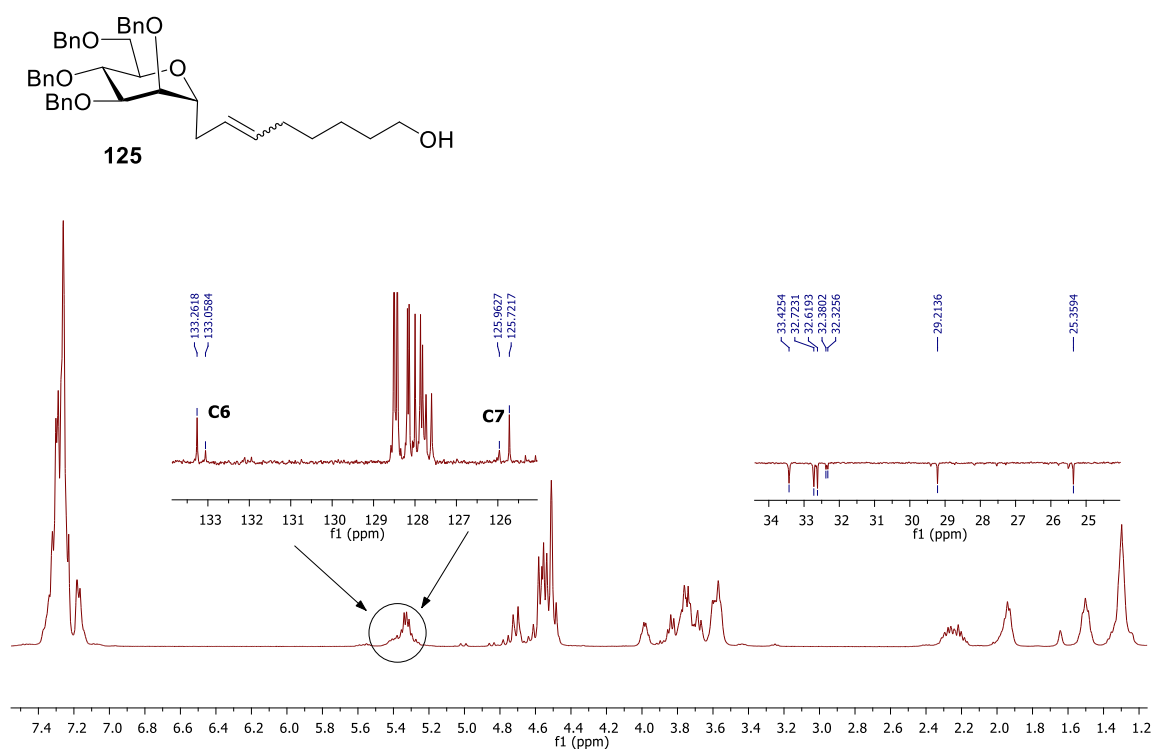
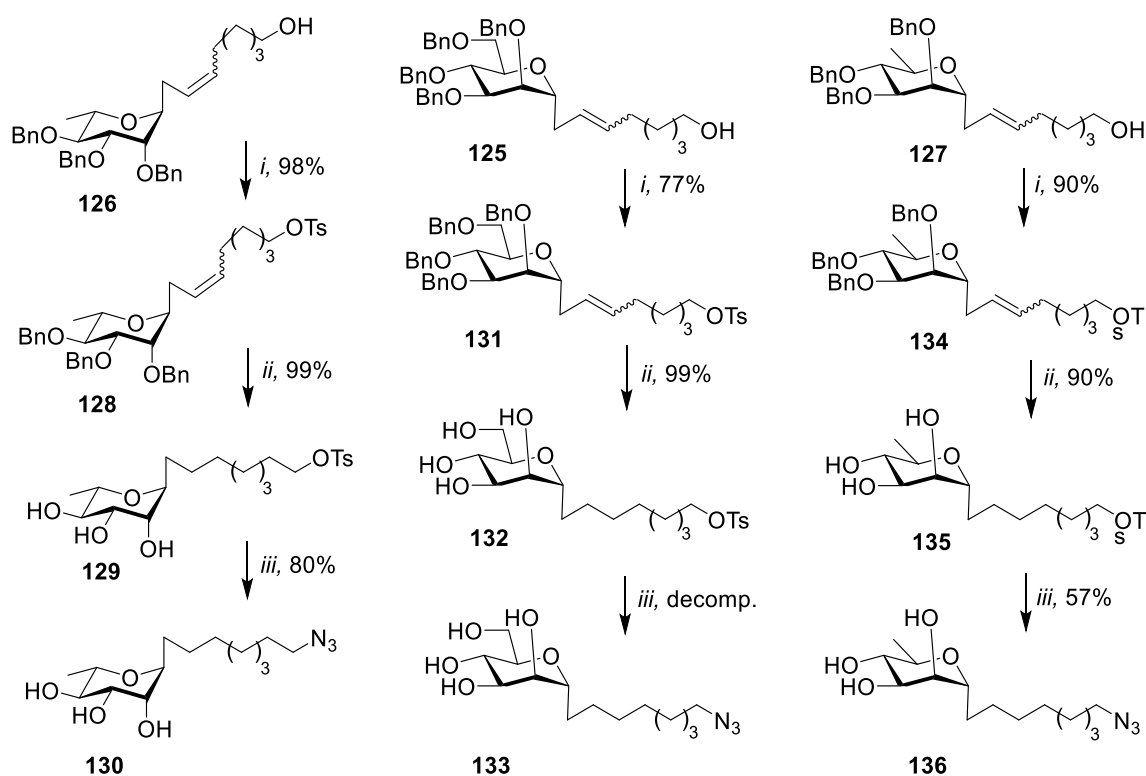

Figure 27: ^1H NMR and DEPTQ of the CM product **43**. Signals for the double bond were expected for an *E/Z* isomeric mixture.

Thus, starting with CM products **125**, **126**, and **127**, all three azido target compounds **130**, **133**, and **136** were prepared according to the general (Scheme 30). Compounds **128**, **131** and **134** were prepared by tosylation of the hydroxyl groups via $\text{S}_{\text{N}}2$ reaction.⁹⁵ The double bond of the alkenes **128**, **131** and **134** were hydrogenated to provide the saturated L-rhamnose derivative **129**, D-mannose derivative **132**, and D-rhamnose derivative **135**, respectively. Concomitantly, deprotection of the benzyl ethers was achieved. ^1H NMR analysis indicated that all benzyl ethers had been removed and that the typical signal for the double bond at 5.75-5.64 ppm had vanished. The final step was the nucleophilic substitution of the tosylate with azide. Both rhamnose derivatives **130** (80%) and **136** (57%) were isolated after purification by column chromatography. However, the introduction of the azido group in to the mannose derivative to produce **133** did not work.

The individual preparations are discussed in detail below.



Scheme 30: General scheme for all sugars, *i*. TsCl, pyridine; *ii*. Pd(OH)₂/C, EtOAc, MeOH; *iii*. NaN₃, DMF.

4.5.3. The Synthesis of Azido L-rhamnose Derivative 130 via CM

This synthesis started with the previously described L-rhamnose derivative **92**. Thus, compound **92** was reacted with 6-hepten-1-ol **88** in a 2:1 molar ratio to give the corresponding coupling product **126** in a CM reaction, using 2nd generation Grubb's catalyst, in 53% yield. The NMR showed the assumed *E/Z* diastereomeric mixture. Since, the double bond would be reduced in a later step and only one spot was visible on TLC, no further attempts were made to separate the assumed isomers. In order to introduce the terminal azido group, the ω-hydroxyl group of the chain in compound **126** was firstly substituted by a tosyl group at the ω-position, using tosyl chloride in pyridine and DMAP⁹⁶ giving tosyl derivative **128** in 98% yield using 10 equivalents of TsCl for one hour at room temperature, followed by chromatographic purification. This reaction was also tested with three equivalents of TsCl in pyridine in an overnight reaction at room temperature but only a yield of 45% of compound **128** was obtained (**Scheme 31**).

Next, the double bond of alkene **128** was reduced under H₂ atmosphere and Pd(OH)₂/C,⁹⁷ to give the saturated compound **129** in 99% yield. The benzyl ethers were also removed during this reaction. At this stage, we expected to obtain uniform material. While the DEPTQ clearly shows only the two expected quarternary signals at 146.4 and 134.6 ppm for the tosyl group and one set of signals for the ring carbon atoms, there are additional signals in the chemical shift range for the linker and also the pseudo anomeric is split. At the same time, the proton NMR is clearer than after the CM and integrates for one compound but the signals for the linker are not well resolved due to overlap. The possibility of conformational isomers, due to slow isomerisation compared to the NMR timescale, could later be excluded when uniform material was prepared via the Wittig approach. Thus, compound **129** is likely to contain an unknown impurity and is not a mixture of conformers.

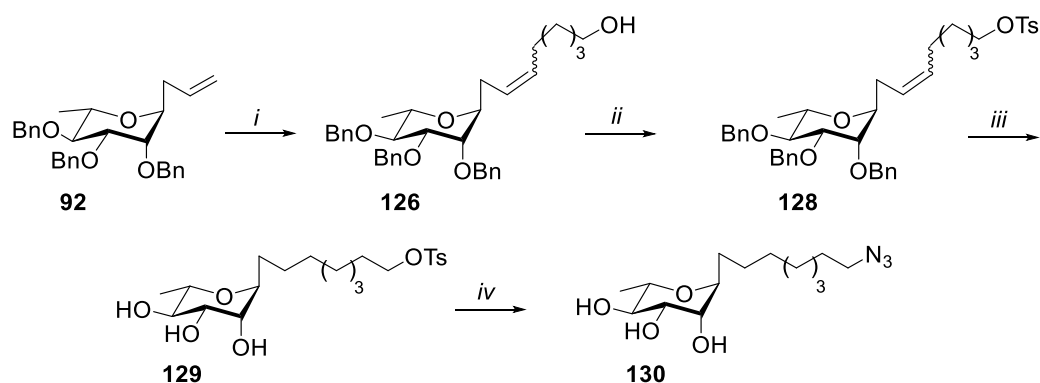

Scheme 31: *i.* hept-6-en-1-ol **88**, Grubb's 2nd G., DCM 53%; *ii.* TsCl, pyridine 1h, 98%; *iii.* Pd(OH)₂/C, EtOAc/ MeOH(1:1), overnight, 99%; *iv.* NaN₃, DMF, 2h, 130 °C, 80%.

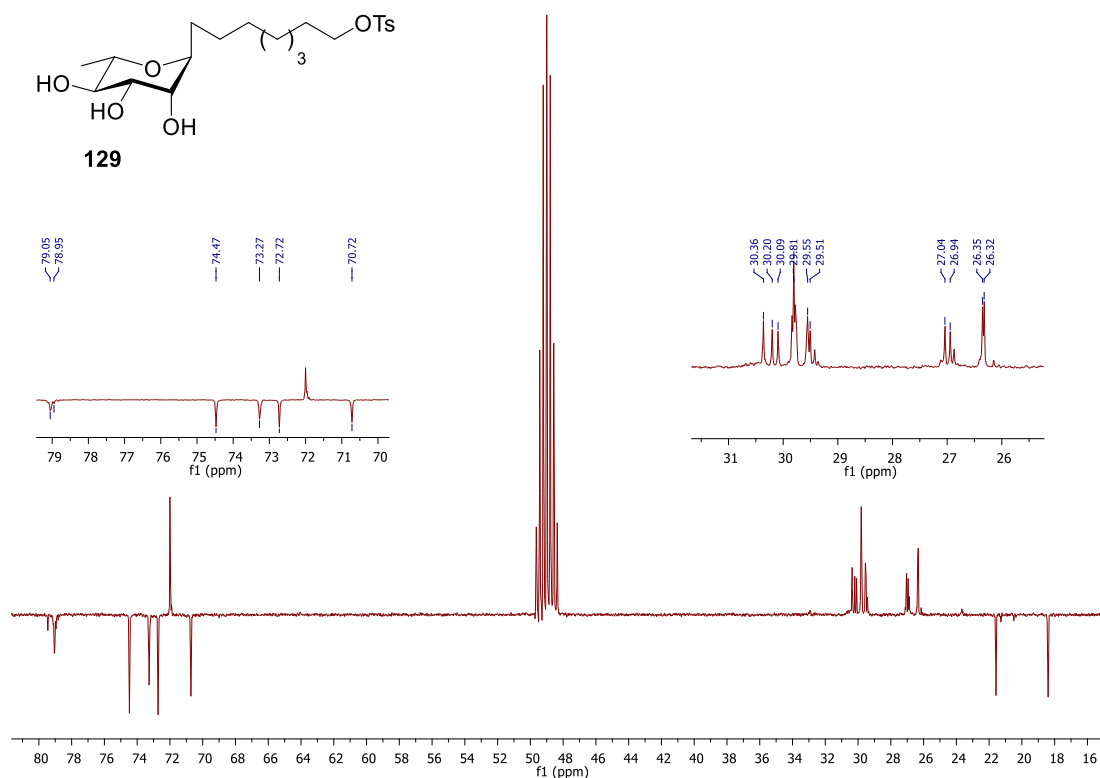

Figure 28: NMR after hydrogenation shows fewer signals.

Hoping that the unknown impurity could be removed at the last step, compound **129** was converted into the target compound **130** containing the terminal azide group by reacting **129** with NaN_3 in dry DMF ⁹⁸ giving compound **130** in an 80% yield (**Scheme 31**). However, while the ^1H NMR shows the expected signals. The DEPTQ clearly indicates an impurity due to additional signals in the chemical shift range of the linker.

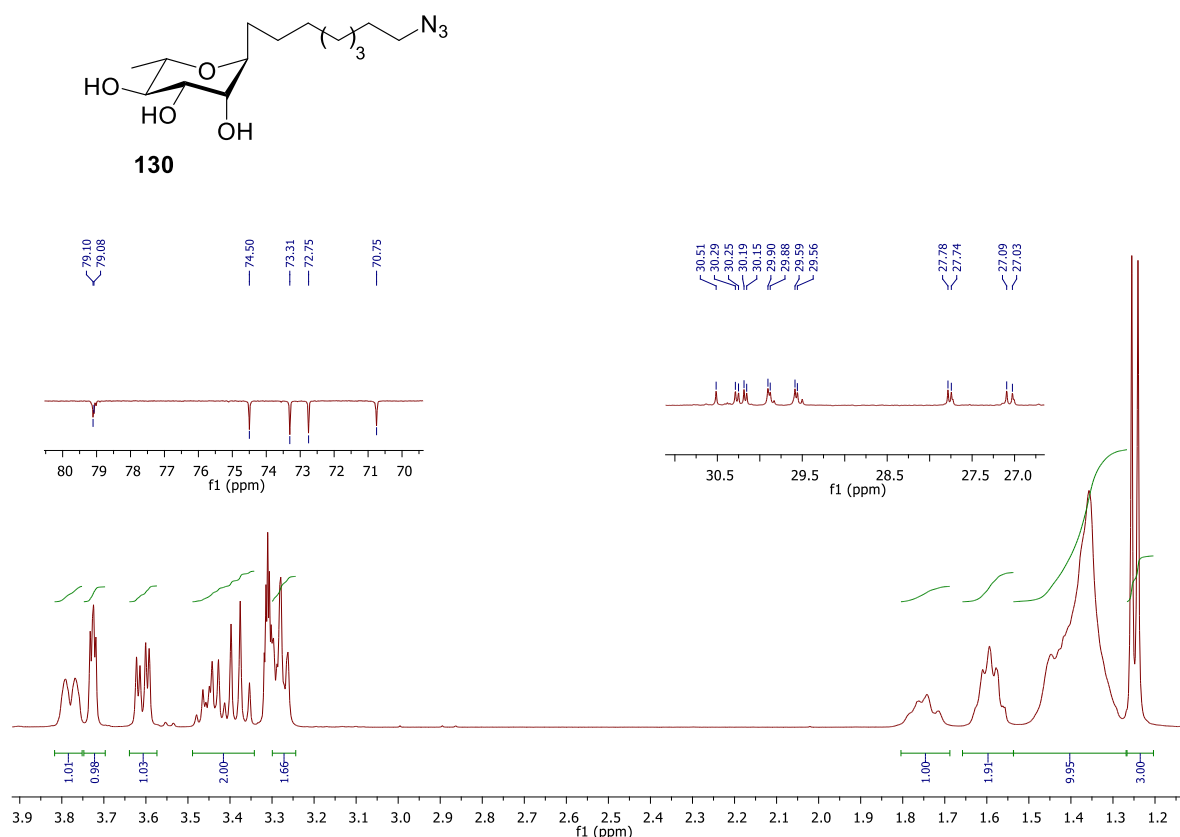

Figure 29: After the final step there are still extra peaks in the ^{13}C NMR.

4.5.4. Synthesis of Azido D-mannose Derivative **133** via CM

Following the procedure developed for the CM on a small scale, D-mannoside **125** (**Scheme 32**) was obtained by coupling compound **11** with 6-hepten-1-ol **88** in a 2:1 molar ratio to give compound **125** in 57% yield. Again, the NMR indicated the presence of an assumed *E/Z* mixture. Tosylate of compound **125** was then prepared by substitution of the ω -hydroxyl group of the chain with the tosyl group, giving **131** in 77% yield using 10 equivalents of TsCl.

The reduction of (8'-(4-Toluenesulfonyloxy)oct-2'-en)-2,3,4,6-tetra-*O*-benzyl-1-*C*- α -D-mannopyranose **131** carried out before the last step using $\text{Pd}(\text{OH})_2$ on charcoal to give **132** in 99% yield. In this step, both the double bond of alkene **131** and the benzyl ethers were removed.

In final step, the compound **132** then was reacted with sodium azide in DMF to give the target molecule **133**. However, during the substitution reaction the mannose derivative **133** did not work, the TLC showed many spots and no product was isolated (**Scheme 32**). Thus, **133** was not accessible via this route in our hands.

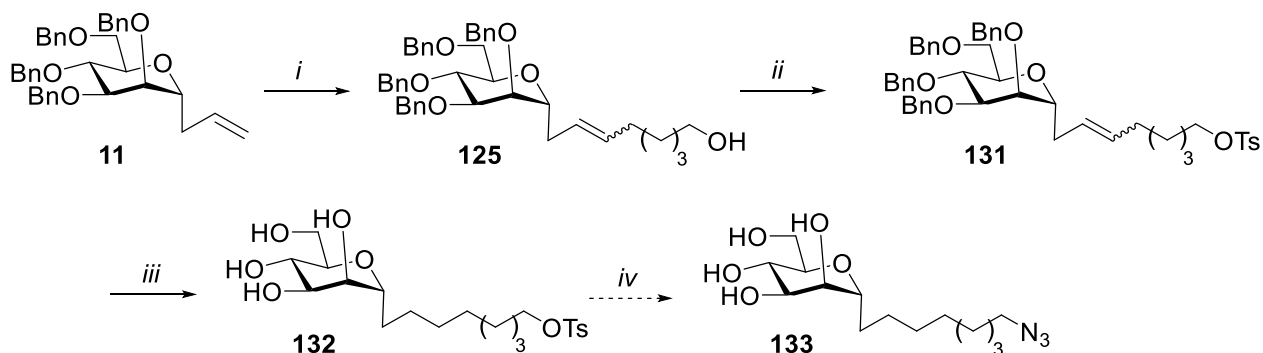

Scheme 32: *i.* hept-6-en-1-ol **88**, Grubb's 2nd G., DCM 57%; *ii.* TsCl, pyridine 1h, 77%; *iii.* Pd(OH)₂/C, EtOAc/ MeOH(1:1), overnight, 99%; *iv.* NaN₃, DMF (decomposition).

4.5.5. Synthesis of Azido D-rhamnose Derivative **136** via CM

In order to prepare the D-rhamnose derivative **136** (Scheme 33), the above described compound **103** was reacted with 6-hepten-1-ol **88** to give compound **127** by CM in 55% yield. As before, assumed *E/Z* diastereomers were visible in the NMR and the material used for the following steps. Compound **134** was then obtained by substituting ω-hydroxyl group with the tosyl group. A yield of 90% for **134** achieved with using 10 equivalents of tosyl chloride. Again, using only three equivalents TsCl gave only 45% of tosylate **134**. The reduction of the double bond and the removal of the benzyl ethers was carried out using H₂ atmosphere and Pd(OH)₂/C giving **135** in 90% yield. Substitution tosyl group with the azido group gave the target molecule **136** in 57% yield after chromatography.

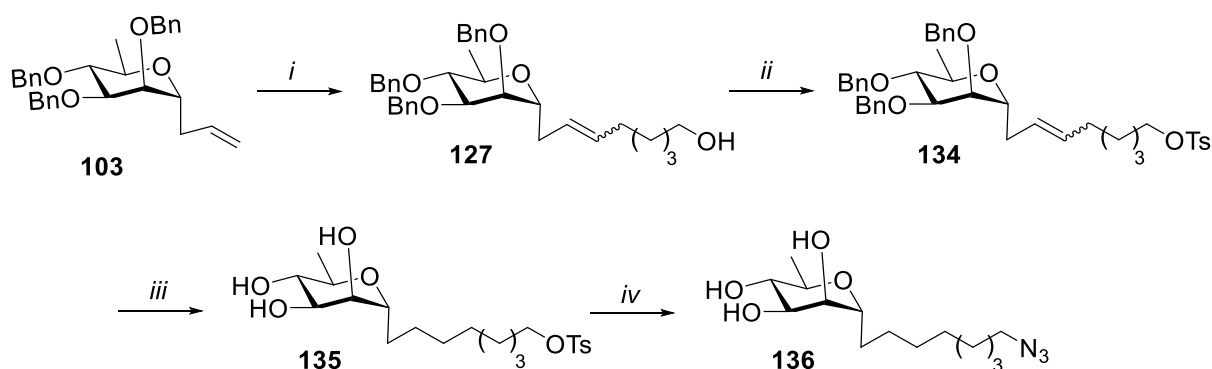

Scheme 33: *i.* hept-6-en-1-ol **88**, Grubb's 2nd G., DCM 55%; *ii.* TsCl, pyridine 90%; *iii.* Pd(OH)₂/C, EtOAc/ MeOH(1:1) 90%; *iv.* NaN₃, DMF 57%.

The proton NMR integrates again to a uniform compound, while the DEPTQ shows additional signal. However, the spectrum obtained is otherwise very clear, only the pseudo anomeric signal is split in an approximate ratio 2:1 and six of the eight linker carbon atoms are split in a similar ratio. While it is not possible with the obtained DEPTQ experiment to gain absolute integrals for all signals, signals with similar expected relaxation time - as most of the methylene groups in the linker - can be approximately compared with each other. Six of those seven comparable signals show the 2:1 split as for the pseudo anomeric centre and integrate approximately to 1.5 for the split signal, while the remaining CH₂-signal at 29.1 ppm integrates approximately to 1.

According to this NMR data, one carbon atom seemed to have gone missing during one of the reactions. Since the NMR for the hept-6-enol **88** showed a uniform compound, we assumed that the culprit is the CM reaction.

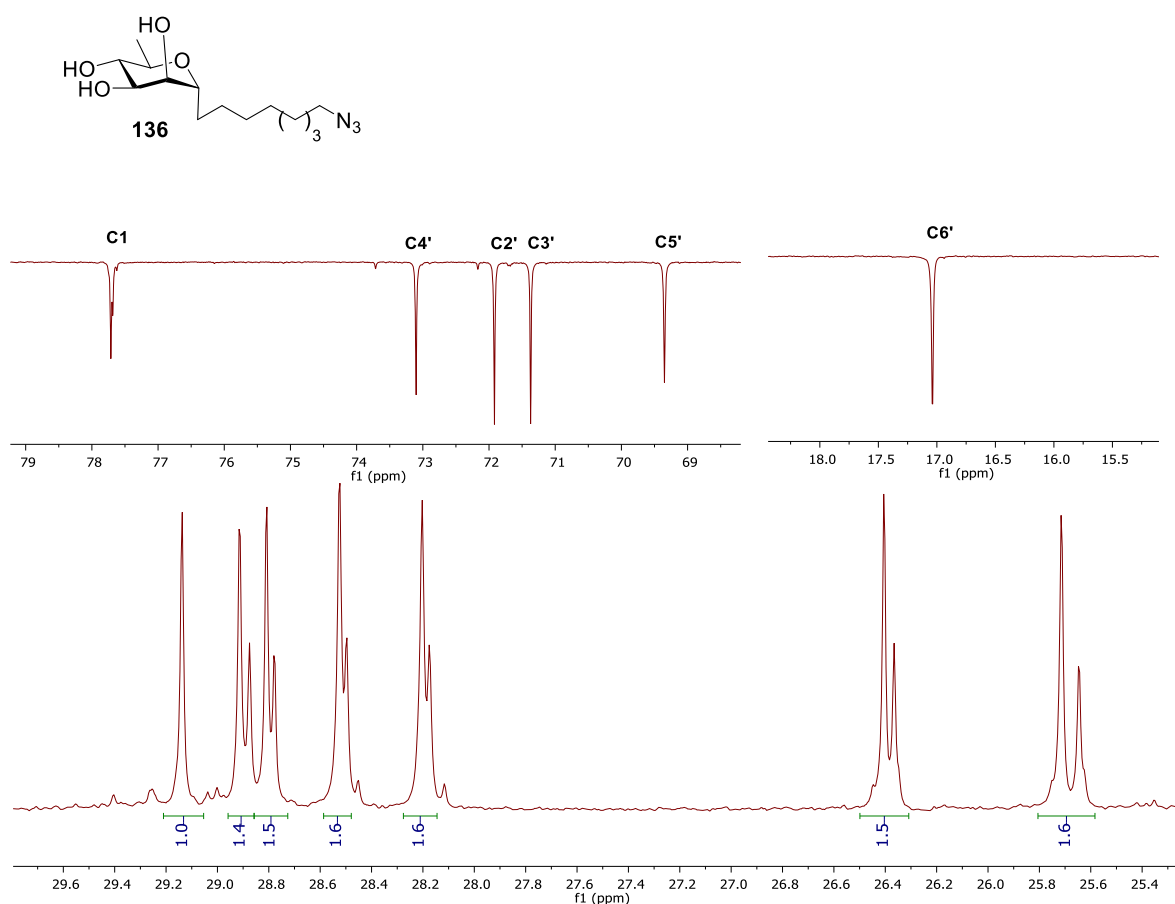
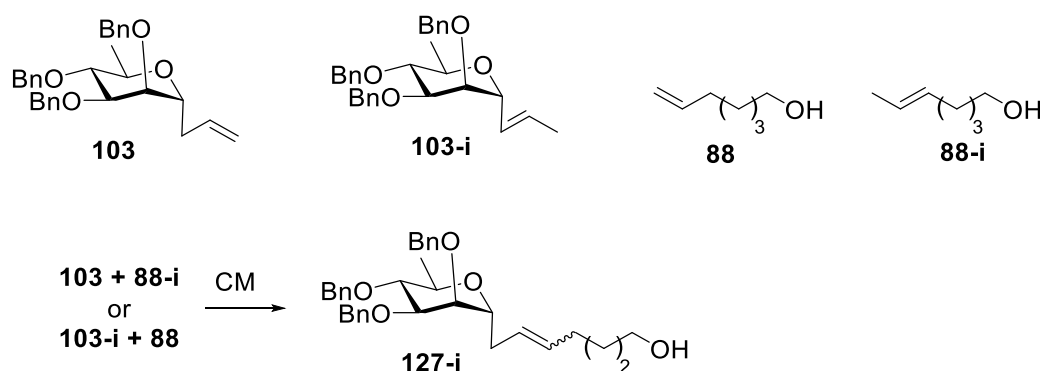

Figure 30: ¹H NMR and DEPTQ of the CM product **136** show split signals of anomeric centre and linker.

Olefin isomerization/migration is a known problem to occur during CM. This migration can produce side products which are generally difficult to separate from the desired CM products via standard purification techniques. Migration and isomerisation is observed when the CM is carried out in high temperature, long time or high dilution and thus reduce the yield of the CM products.⁹⁹ Since the reaction was run overnight in contrast to the suggested one hour in literature in order to obtain a high conversion, this could have been the case during our experiments. Isomerised starting materials **103-i** and **88-i** would produce the CM product **127-i** with one less carbon atom as the expected CM product **127** (**Scheme 33-i**).



Scheme 33-i: Possible isomers of the olefins **103** and **88** and the CM product **127-i** results in the loss of one carbon in the linker.

In conclusion, compounds **130**, **133**, **136** were made. However, additional signals were appeared in the ¹³C NMR. According to NMR data, carbon atoms seemed to have gone missing during one of the reactions and confirmed by mass analysis as shown below (**Figure 33-ii**).

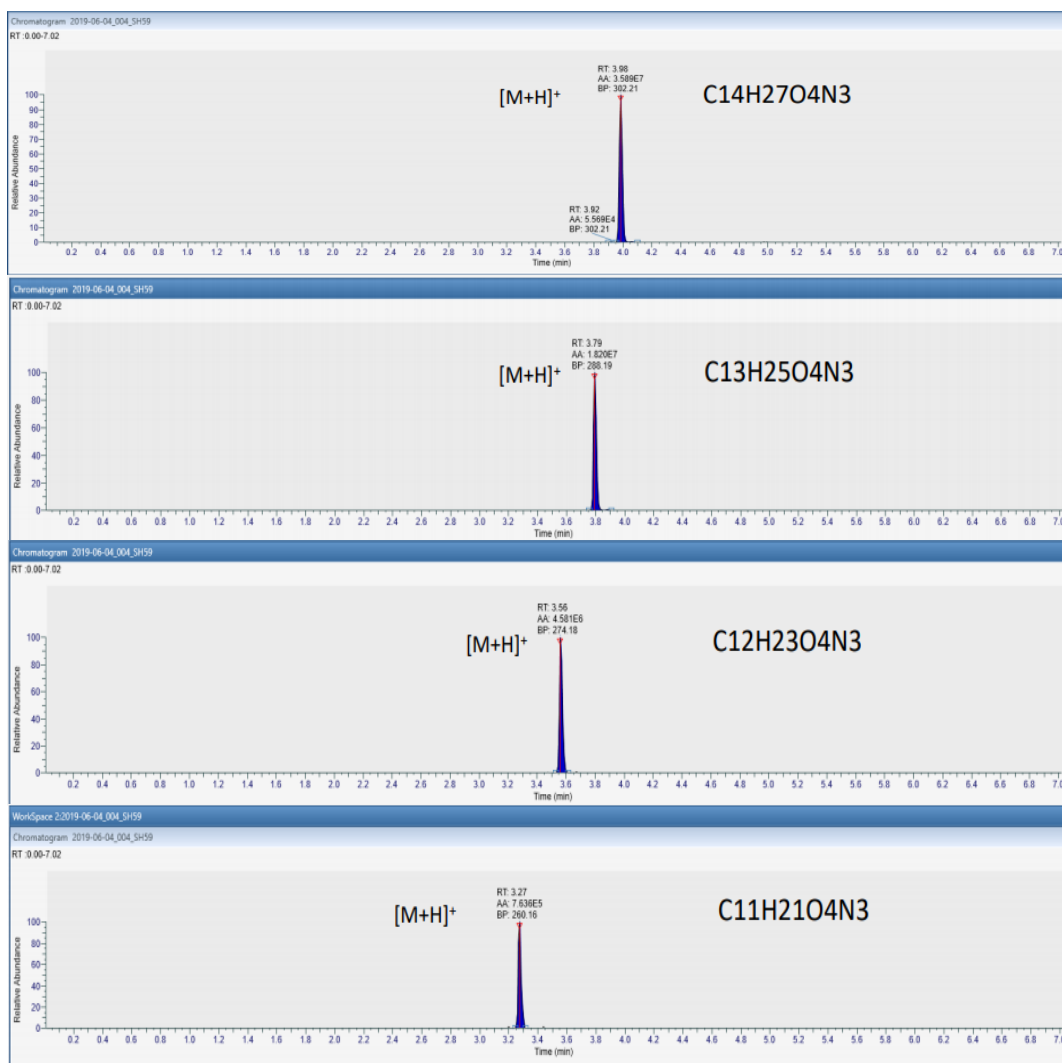
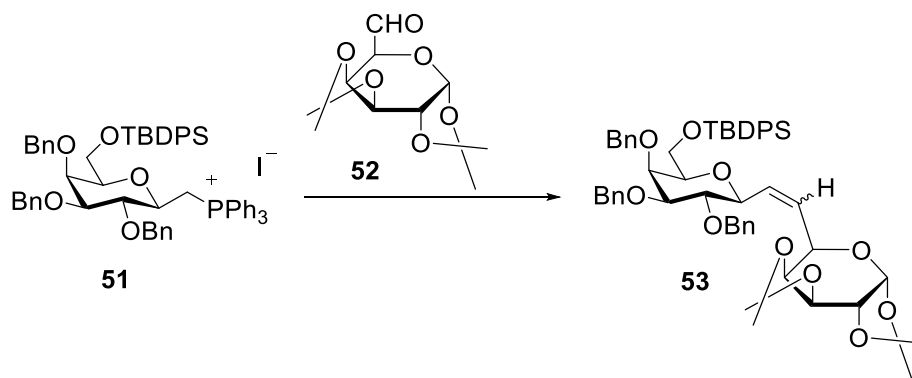

Figure 33-ii: Mass analysis shows different isomers due to migration during CM.

4.6 Wittig Olefination

The Wittig reaction is one of the most effective C-C coupling reactions in organic synthetic chemistry, reacting an aldehyde or ketone with a phosphonium ylide generating an alkene linkage between the two reactants. The general procedure for the Wittig reaction requires organolithium or strong base such as *n*-BuLi in anhydrous solvent (**Scheme 34**) to generate *in situ* the phosphonium ylide from the corresponding phosphonium salt which is also called Wittig salt. The stereochemistry of the double bond in the product relies on the structure of the ylide. Non-stabilised ylides produce primarily the *Z*-isomer which is the kinetic reaction product, while resonance stabilised ylides show a preference for the thermodynamic *E*-isomer. The Wittig salt is often prepared by the substitution of a suitable alkyl halide with triphenylphosphine. However, some Wittig salts are commercially available. The phosphonium salt is then deprotonated to give the ylide, followed by the addition of the carbonyl component. Although, betaine species, formed by a nucleophilic attack of the ylide to the carbonyl carbon, have not been ruled out by mechanistic studies, it is assumed that the carbonyl component reacts with the ylide in an [2+2]-cycloaddition forming a 4-membered ring, a oxaphosphetane. This intermediate then collapses to produce the alkene product and a phosphine oxide.^{100,101}



Scheme 34: Example of a Wittig coupling with BuLi, THF, -50 °C, 70%, giving a mixture of the *E* and *Z* diastereomers in a 1:9 ratio.²⁷

Previous work in our group (**Scheme 35**, unpublished results)⁷⁶ prepared the target azido compound **133** starting from D-mannoside **66** using the Wittig coupling reaction as a key step. A major drawback of this reaction sequence is the final step where the azido group was introduced by the substitution of a mesyl group, giving **133** in only 7% yield.

For this project, the L-rhamnose reference target **130** was chosen to find out whether this otherwise high yielding route could be improved. Then, these improved conditions were applied to the D-mannose and D-rhamnose targets **133** and **136**, respectively.

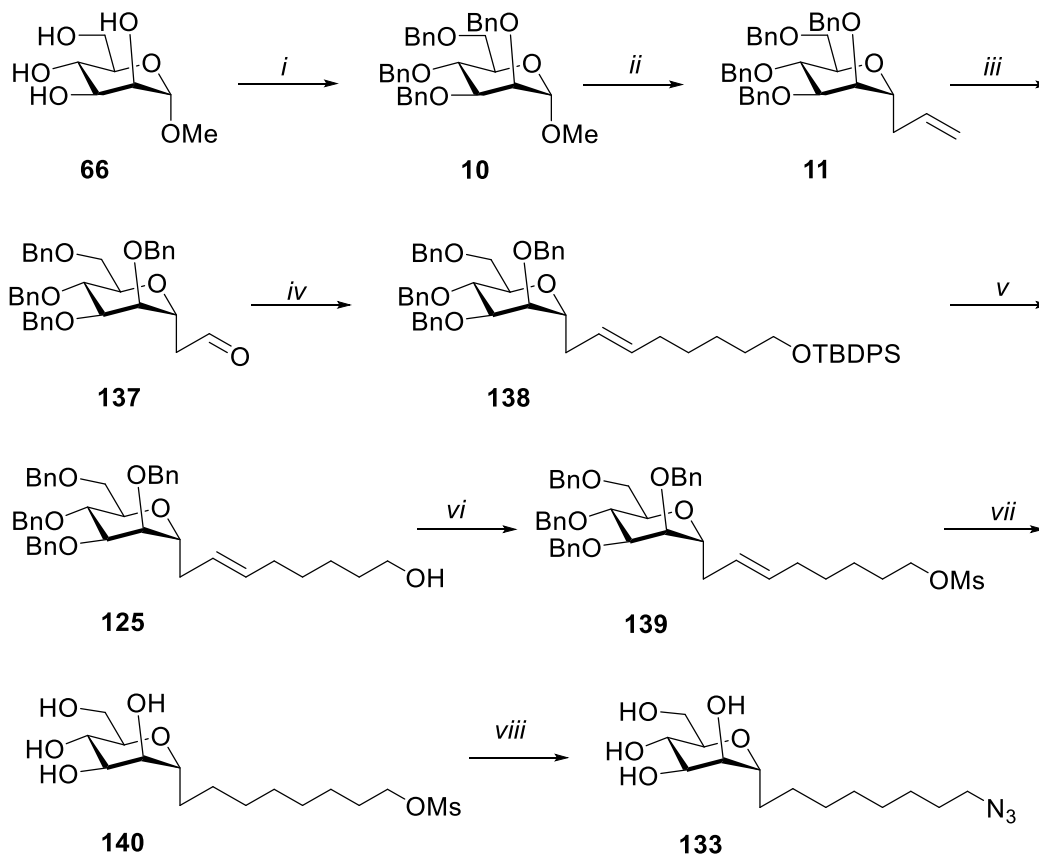

Scheme 35: Synthesis of 1-deoxy- α -1-(8'-azido-oct-1'-yl)-D-mannose. *i.* NaH (6eq), BnBr (5eq), DMF, 18h, rt, 88%; *ii.* AllylTMS (2.7eq), trimethylsilyltriflate (0.5eq), CH₃CN, 25h, rt, 80%; *iii.* O₃, PPh₃ (1.5eq), DCM, 78%; *iv.* LiHMDS (2eq), THF, DMPU, Wittig salt **83**, -78 °C, 84%; *v.* TBAF (3eq), THF, 3h, rt, 97%; *vi.* MsCl (1.5eq), Et₃N, DCM, 2h, rt, 97%; *vii.* Pd(OH)₂/C, EtOAc/MeOH(1:1), 2.5h, rt, 75%; *viii.* NaN₃ (3eq), DMF, 80°C, overnight, 7%.⁷⁶

4.6 1. Synthesis of Aldehyde Compounds **141**, **137**, **143** by Ozonolysis

In order to introduce the Wittig reaction required carbonyl group, the benzylated allyl intermediates **92**, **11**, and **103**, discussed previously for the CM approach, were oxidised to the corresponding aldehydes by ozonolysis applying a typical ozonolysis procedure.¹⁰² Thus, ozone was bubbled through a solution of an allyl pseudo sugar, at -78°C in DCM until a persistent blue colour was obtained. This colour indicated the complete consumption of the starting material,

thus excess of ozone accumulated in the DCM solution. After removal of the ozone source, the blue colour disappeared after a couple of minutes. At this stage a colourless solution was obtained and the formation of the intermediate secondary ozonide was assumed. In order to convert the intermediates to the desired aldehyde triphenylphosphine was added to the reaction mixture.

The mechanism of ozonolysis was proposed by Rudolf Criegee. In the first step of this mechanism, the primary ozonide is formed in an 1,3-dipolar cycloaddition giving the molozonide. Subsequent intermediates undergo a further 1,3-dipolar cycloaddition to give a 1,2,4-trioxolane which is also called the secondary ozonide. This ozonide is more stable than primary ozonide.¹⁰³

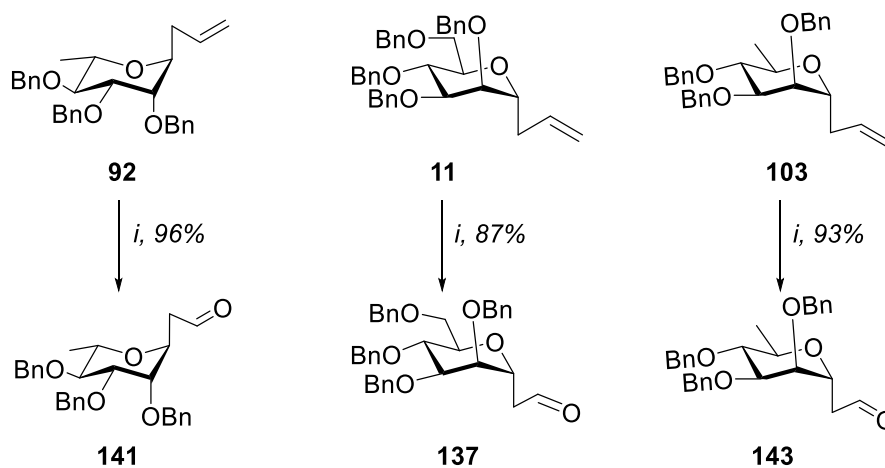

Scheme 36: Ozonolysis of compounds **92**, **11**, and **103** give the corresponding aldehydes **141**, **137**, **143**. *i.* O₃, PPh₃, DCM, -78°C.

The ozonolysis gave overall excellent yields. L-Rhamnose **141** was isolated in a yield of 96%. This product **141** was confirmed by ¹H NMR spectroscopy showing a triplet at δ_H 9.64 ppm belonging to the aldehyde proton (**Figure 31**). In addition, the ¹³C NMR spectrum showed a signal at δ_C 200.5 ppm indicative for the presence of an aldehyde group. In the same fashion D-rhamnose **143** was produced in a yield of 93% and analysed by NMR.

Ozonolysis of D-mannose **11** gave the corresponding aldehyde **137** in yield 87% as colourless syrup, and the successful conversion was again confirmed by NMR analysis showing the indicative the proton of aldehyde group as a triplet at 9.69 ppm in the ¹H NMR and a signal at 200.6 ppm in the DEPTq.

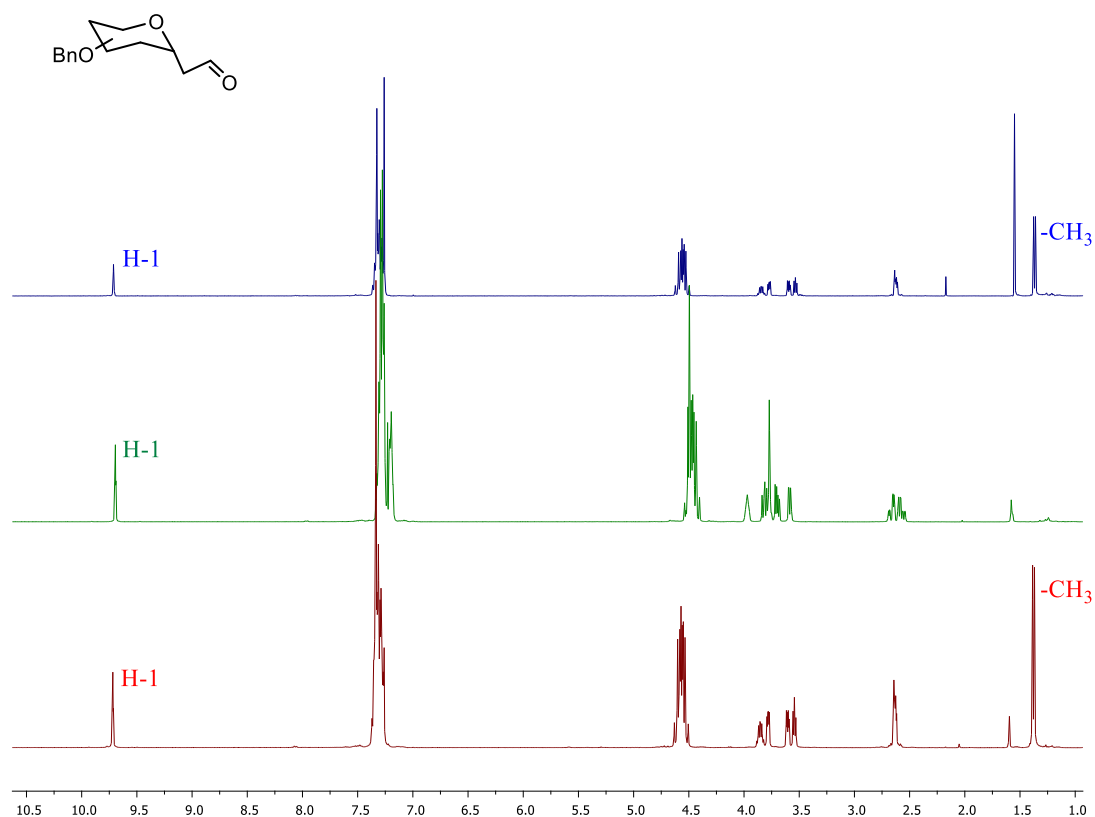
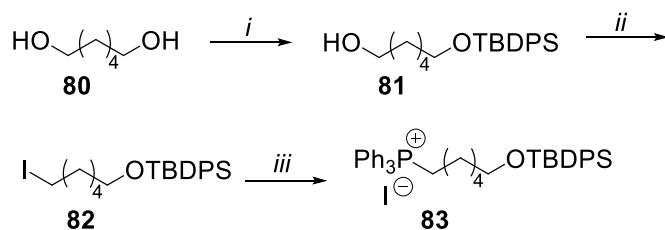

Figure 31: ^1H NMR of compounds **141**, **137**, **143** is shown a triplet signal in down field for the aldehyde group.

4.6.2. Synthesis of Phosponium Salts

Since the phosphonium salt for the C-C coupling reaction was not commercially available, 1,6-hexanediol **80** was converted into phosphonium salt **83** in three steps (**Scheme 37**).

Following a published procedure, the selective mono-*O*-TBDPS protection was accomplished in a biphasic reaction medium. Thus, *N,N*-diisopropylethylamine (DIPEA) was added to a solution of 1,6-hexanediol **80** in dry DMF forming a biphasic mixture at rt. Then TBDPSCl was added. The required mono-*O*-TBDPS protected hexanol **81** was isolated in 50% yield.¹⁰⁴



Scheme 37: *i.* TBDPSCl, DIPEA, DMF (overnight, rt), 50%; *ii.* imidazole, I₂, PPh₃, DCM (48h, rt), 93%; *iii.* PPh₃, CH₃CN (reflux, overnight), (64%-80%).

Silyl ether **81** was then converted into 6-((*tert*-butyldiphenylsilyl)oxy)-1-iodo-hexane **82** using I₂, imidazole and PPh₃ in DCM to give 93% yield after stirring overnight.¹⁰⁵ After reaction of **82** with PPh₃ in CH₃CN, the phosphonium salt **83** was isolated by column chromatography.¹⁰⁶ The oily product **83** was then precipitated from diethyl ether to give a white solid in 64 % yield. At a later stage, this reaction was repeated giving a yield of 80%.

In order to see whether the counter ion of the phosphonium salt has any impact on the Wittig coupling, the phosphonium bromide **147** was prepared as an alternative (**Scheme 38**). The conversion from **80** to **145** gave a yield of 54% using HBr (48%) in toluene. This reaction was stirred overnight in oil bath at 115 °C. The hydroxyl group was then protected with the silyl ether to give compound **146** in 97%, followed by substitution with PPh₃ giving **147** in 78% yield.^{107,108,109}

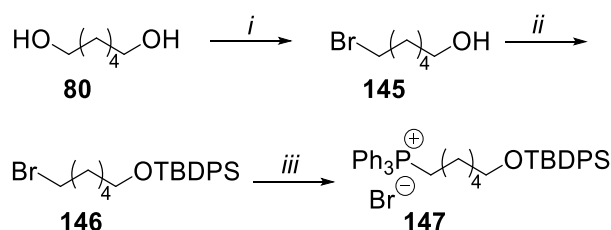

Scheme 38: *i.* HBr (48%), toluene, (reflux, overnight), 54%; *ii.* TBDPSCl, imidazole, DCM (overnight), 97%; *iii.* PPh₃, CH₃CN (reflux, overnight), 78%.

4.6.3 Synthesis of **138**, **142**, **144** Using Wittig Coupling Reaction

The Wittig reaction was the second choice to obtain 8-(1'-deoxy- α -L/D-glycopyranos-1'yl)-oct-1-azide compounds after failure to obtain the final compounds **130**, **133**, **136** as pure compounds.

Based on the previous work on D-mannose **133** in our group,⁷⁶ the Wittig reaction was carried out with the synthesised phosphonium salt **83** (Scheme 37) and the above described aldehydes **141**, **137**, **143** (Scheme 36) giving the corresponding coupling products **142**, **138** and **144** in yield 46%, 80% and 46% respectively (Scheme 40).

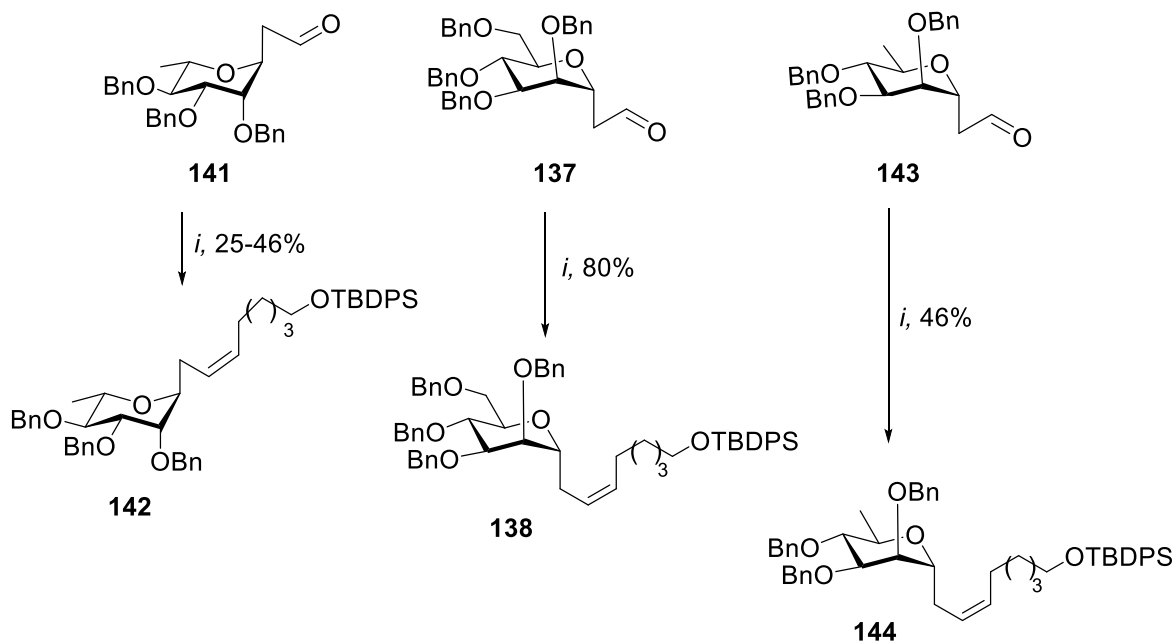

Scheme 40: Scheme shows synthesis of the coupling compounds **142** (46%), **138** (80%), **144** (46%).
LiHMDS, THF, DMPU, -78 °C and iodo phosphonium salt.

The same procedure was applied for the three Wittig couplings. Lithium hexamethyldisilane (LiHMDS) was used as a base in the presence of *N,N'*-dimethylpropylene urea (DMPU) for the ylide formation, and a bright orange colour was formed after adding the base to the phosphonium salt **83** at -70°C indicating the formation of the ylide. Then a solution of one of the aldehydes **141**, **137**, **143** was added to the reaction mixture. After work-up the products were purified by flash-chromatography and analysed by NMR.

While the reaction with the D-mannose derivative **137**, provided a satisfying yield, the reactions with both rhamnose derivatives (**141** and **143**) were only moderate. All reactions were monitored by TLC and gave independently of the starting aldehyde spot to spot reactions indicating complete conversion. Also, the chromatographic step seemed to work fine for all three reactions. However, the above results are still much better than the first trials with L-rhamnose **141** where only 25% yield was obtained after Wittig coupling. Also, using the alternative bromo Phosphonium salt **147** did not improve the yield of the Wittig coupling. It was speculated that

material could have been lost during the work-up procedure which seemed unlikely since the physical properties of the three Wittig products are quite similar. Since no side products were observed, extreme care was taken by keeping dry conditions during the reaction which eventually rose the yield to moderate 46% for the rhamnose derivatives. No further investigations were performed, since sufficient material had been produced.

In the ^1H NMR, signals for the double bonds appeared between δ_{H} 5.42-5.18 ppm while the triplet from the aldehyde between 9.72-9.64 ppm had disappeared (**Figure 32**). In addition, the successful conversion was also confirmed by ^{13}C NMR data which showed signals at about 132 ppm and about 125 ppm again indicative for the presence of double bond in the Wittig products. While inseparable impurities were obtained in the CM (**Figure 27**), the Wittig reaction provided clean compounds (**Figure 33**). From these results it was concluded that the synthesis via the Wittig reaction, although slightly longer, was the better sequence for the target compounds.

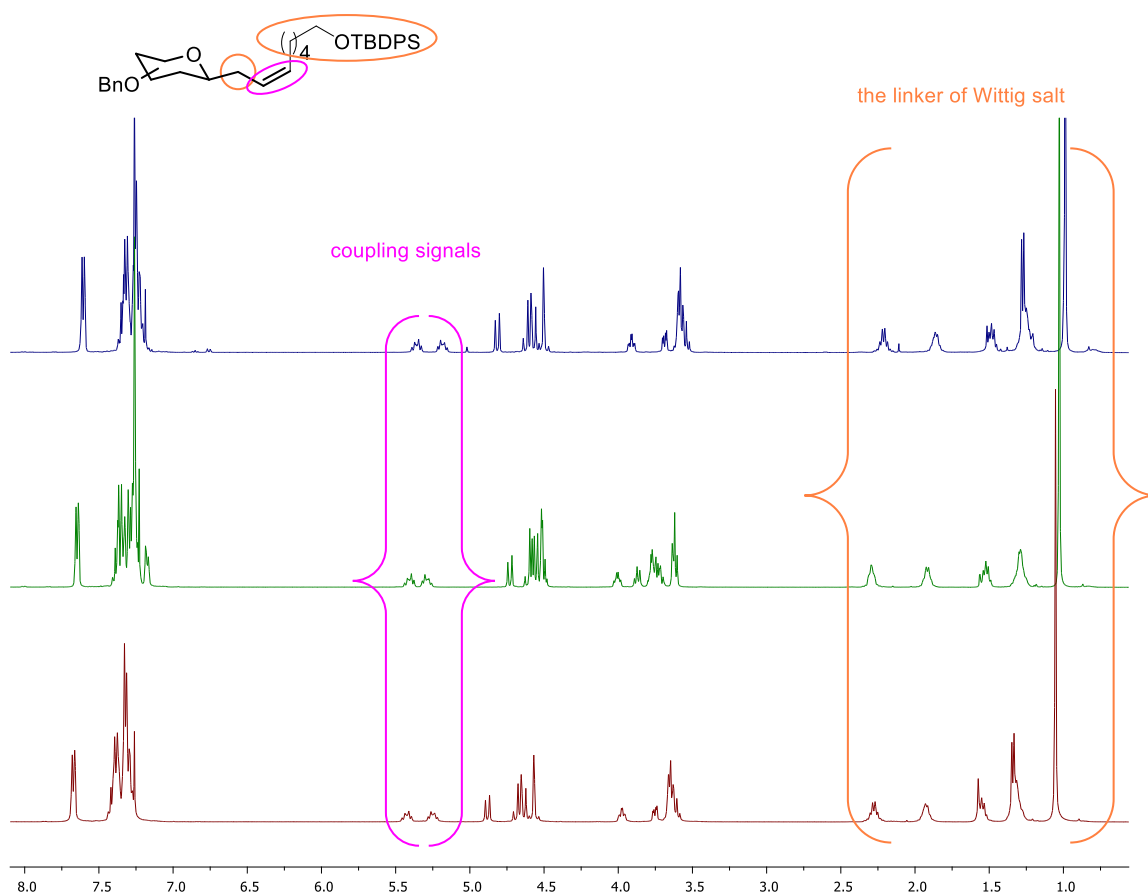
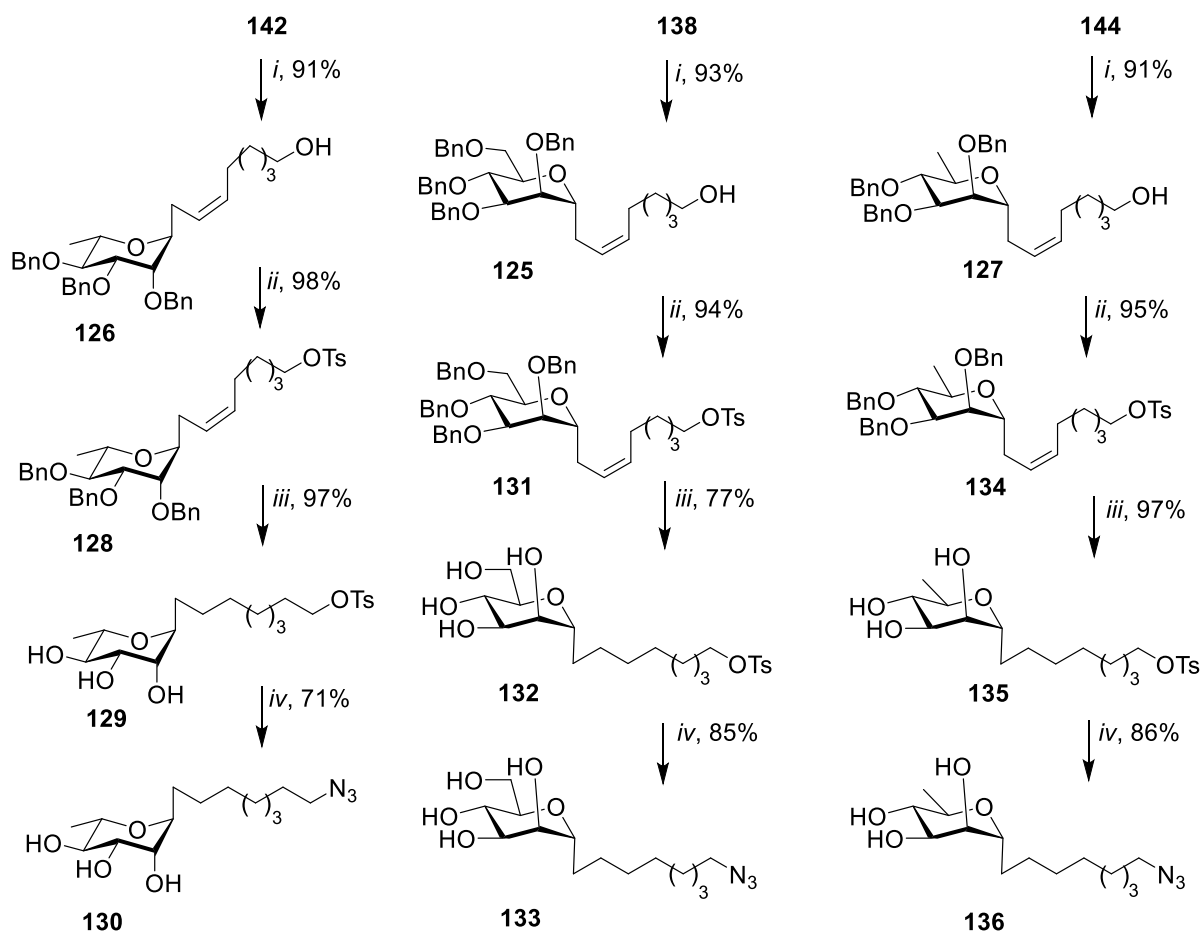

Figure 32: ^1H NMR of the Wittig compounds **142**, **138**, **144**. The alkene signals (purple brackets) are indicative the successful reaction.

4.6.4 Synthesis of The Compounds 130, 133, 136.

After the Wittig reactions, the TBDPS group of the Wittig products was selectively cleaved with TBAF¹¹⁰ giving the free alcohols **126**, **125**, **127** in excellent yields 91%, 93% and 91% respectively (**Scheme 41**).



Scheme 41: Conversion of the Wittig products into the final azido targets, *i.* Wittig compound, TBAF, THF; *ii.* TsCl, pyridine; *iii.* Pd(OH)₂/C, EtOAc, MeOH; *iv.* NaN₃, DMF, 130°C.

In order to introduce the terminal azido group, the ω -hydroxyl group of the chain in compounds **125**, **126**, **127**, the terminal alcohol group had to be converted into a good leaving group. Previous work⁷⁶ indicated problems with the substitution step using the mesyl group as leaving group. Thus, it was decided to try the tosyl group instead, and after chromatographic purification, the tosylated derivatives **128**, **131**, **134** were obtained in good yields of 98%, 94%, 95% respectively using 10 eq. of TsCl in pyridine.

The double bond of the olefinic compounds was reduced under H₂ atmosphere and Pd(OH₂)/C, to provide the saturated and fully deprotected 1-deoxy-alkyl- ω -tosyl pyranosides **129**, **132**, **135** in good yields 97%, 77% and 97% respectively. In the last step, the tosyl group was substituted in a straightforward fashion by sodium azide giving the target compounds L-rhamnose **130** and D-mannoside **133** and D-rhamnoside **136** in yield 71%, 85% and 86% (**Scheme 41**) in comparison to the previously obtained 7% yield for the mesylated D-mannose derivative.⁷⁶

The ¹H NMR analysis confirmed the conversion by the disappearance of the –CH₂-OTs triplet at about 4.02 ppm and the appearance of the –CH₂-N₃ triplet to 3.28 ppm which is overlapping with the MeOD signal.

4.7 Summary

Overall, the pathway via the Wittig reaction produced the better results, since NMR pure material for L-rhamnose **142** (46%), D-rhamnose **138** (46%), and D-mannose **144** (80%) was obtained after the Wittig couplings. The phosphonium iodide **83** was used in the successful Wittig coupling reaction. The phosphonium bromide **147** was trialled for the reaction with L-rhamnose **141** giving about 20% yield of **142**. However, since the couplings with the rhamnose derivatives gave generally much lower yields, not sufficient data has been collected to decide whether there is a difference for these reactions that depends on the counter ion. The target compounds **130**, **133**, **136** have been successfully synthesised and their structures confirmed by NMR spectrum (**Figure 34**). The C-glycoside target molecules of the azide compounds were synthesised in 13 steps for L-rhamnose **130** and D-mannose **133** respectively (total yield is 5% in each case), while D-rhamnose **136** required either 15 steps giving a total yield of 2% or 10 steps with an overall yield of 5% when using the direct reduction pathway (**Scheme 24, part 1**).

These positive results prompted us to move on to the synthesis of the bifunctional linker discussed in the following chapter.

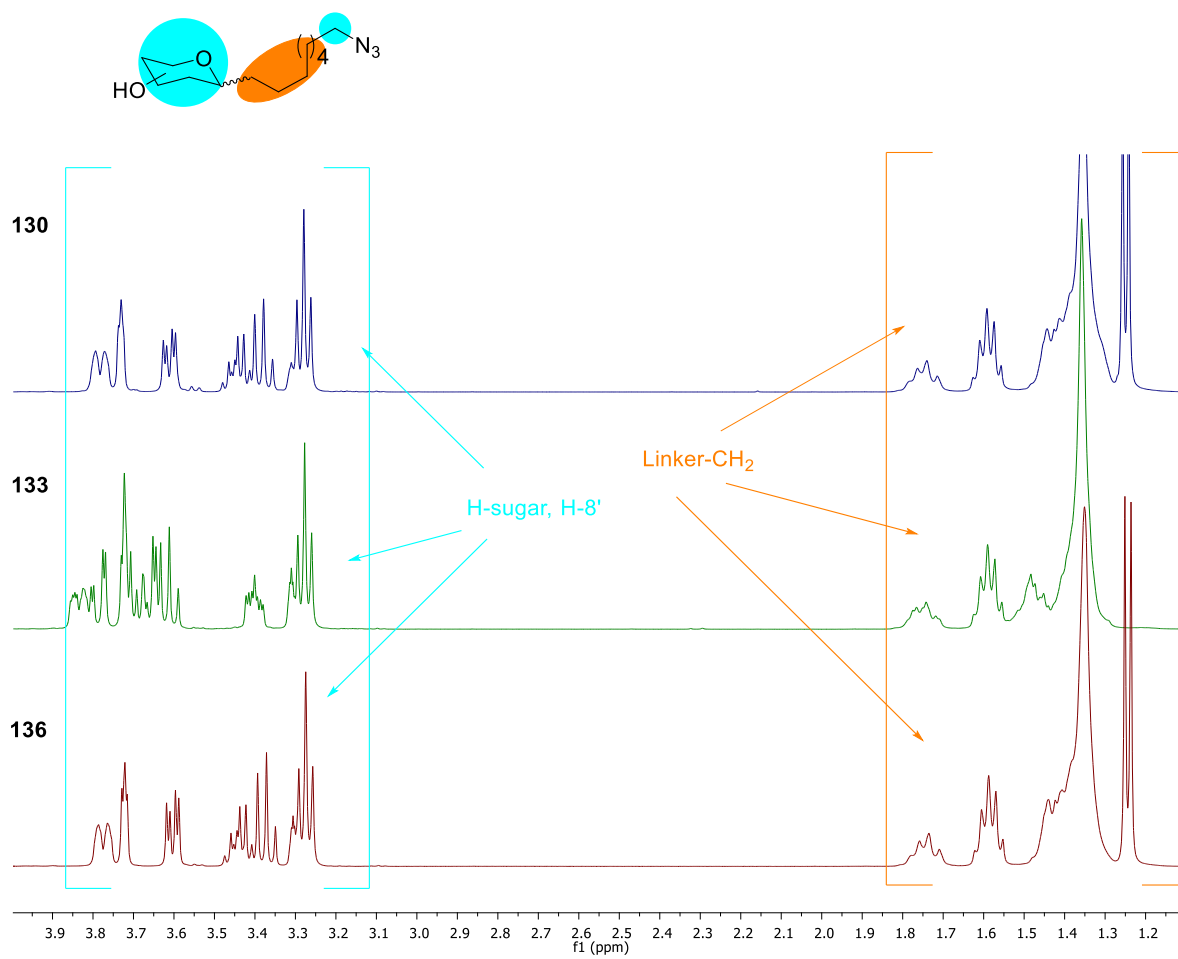

Figure 34: ^1H NMR of compounds **130**, **133**, **136**.

CHAPTER 4

RESULTS AND DISCUSSIONS - PART 2

The synthesis of bifunctional linkers and attempted conjugations

4.8 The Synthesis of Bifunctional Linkers and Attempted Conjugation of The Pseudo Sugars to Alginate

For this project, both alginates and gold nanoparticles were considered as carriers for the *C*-monosaccharide derivatives. Those conjugates would mimic the surface of the bladder lining, and thus provide multivalent presentation of the pseudo-sugar epitopes. Since the *C*-glycosidically 8 carbon linker had been designed to interact fully with the binding site of FimH, an additional spacer, keeping distance between the carrier and the ligand, is required. For this purpose, two small bifunctional DEG-based linkers had to be prepared that can link to, *e.g.*, an alginate via an amide bond or via a thiol group with a gold surface, and also react in an orthogonal fashion with the pseudo-sugar epitopes via a click reaction. In the next section, the synthesis of the bifunctional linker **152** and **171** is discussed. Further, attempts to ligate the linker **152** to alginate is reported, as well as the click reaction of linker **171** to the pseudo-sugar epitopes **130**, **133**, and **136**, producing the conjugates **173**, **174**, and **175** ready for ligation with the gold nanoparticles.

4.9 Synthesis of The Bifunctional Linker 152

Diethylene glycol (DEG) was chosen as the cross-linking starting material due to its properties. A DEG based cross-linker is advantageous due to its biocompatibility and high hydrophilicity. In addition, it is commercially available, soluble in many organic and aqueous systems and easily modified. The flexible DEG, as longer polyethylene glycols, provide elasticity of hydrogel when linking it to the relatively stiff alginate.^{111,112}

4.9.1 First Route for Synthesis of Linker **152** (Staudinger Reactions)

To synthesise the required conjugation linker, DEG was used as starting material to obtain the bifunctional linker **152** in a total yield of 35% over 4 steps following a literature procedure (**Scheme 42**). All yields were in a similar range as reported previously.¹¹³

In the first step, DEG was reacted with tosylchloride giving the tosylate ester **149** in 78% yield using excess of DEG in DCM in the presence Et₃N. Tosylate **149** was then reacted with sodium azide in dry DMF at 130°C for 2 hours to give azide **150** in 90% yield. The hydroxyl group in **150** was then converted into the corresponding alkyne using propargyl bromide to give azide **151** in 78% yield. The last step was reducing the azido group of **151** to the required amino group under Staudinger conditions to produce the bifunctional linker **152** in 63% yield.

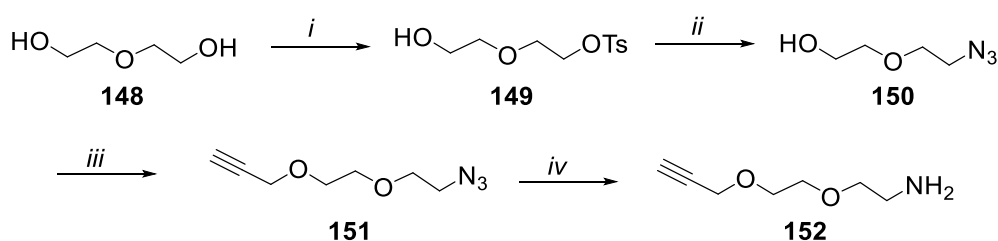

Scheme 42: A synthetic route from DEG to produce the bifunctional linker **152** in a yield of 34 % over 4 steps. *i.* TsCl, Et₃N, DCM, 78%; *ii.* NaN₃, DMF, 90%; *iii.* propargyl bromide, NaH, DMF, 78%; *iv.* PPh₃, H₂O, 63%.

According to TLC analysis, the Staudinger reaction produced a spot to spot reaction with the new spot belonging to the amino product **152**. However, as reported in the literature,¹¹⁴ the ¹H NMR confirmed impurities associated with the triphenyl phosphine and the during the reaction formed triphenylphosphine oxide. Several unsuccessful attempts were made to remove these impurities by column chromatography. For this reason, another synthetic pathway was chosen.

4.9.2 Second Route for Synthesis of The Bifunctional Linker **152**

Using ethylene diamine in ethanol under reflux is a common reaction condition for removal of phthalimido groups, and considered as a safer method than using hydrazine hydrate. However, the side product is often more difficult to be removed. The reaction was tried several times but did not go to completion. Thus, hydrazine was used to convert phthalimide compound into amino compound (**Scheme 43**). The published procedure involved converting the hydroxyl group into the corresponding allyl compound using allyl bromide in 0.33 eq and NaH in THF

to give 73% yield after 1 hour. The second hydroxyl was then converted into tosylate group using tosyl chloride in 1.5 eq and Et₃N to give 80% yield. After preparing the tosyl compound from tetraethylene glycol, next step was synthesised by substitution with phthalimide in DMF to afford 84% yield of the corresponding product. The last step was adding hydrazine hydrate to solution of phthalimide in DCM with stirring at room temperature for overnight to give amine compound in 83% yield.¹¹⁵

The second approach for the synthesis of **152** avoided the problems of the Staudinger reaction by introducing the amine via a Gabriel synthesis. Thus, DEG **148** was alkylated using NaH in THF at 0 °C, followed by addition of propargyl bromide. TLC showed complete conversion after 1 h to give 77% yield of compound **153**. Overnight tosylation of **153** using tosyl chloride in pyridine at 0°C gave tosylate **154** in 54% yield. For the Gabriel synthesis, the substitution of the tosylate in **154** was carried out with sodium phthalimide at 100 °C. This overnight reaction gave compound **155** in yield of 93%. The free amino group was obtained in 91% yield by reacting **155** with excess of hydrazine hydrate in DCM (**Scheme 43**). All steps were followed by TLC and the obtained compounds analysed by NMR.

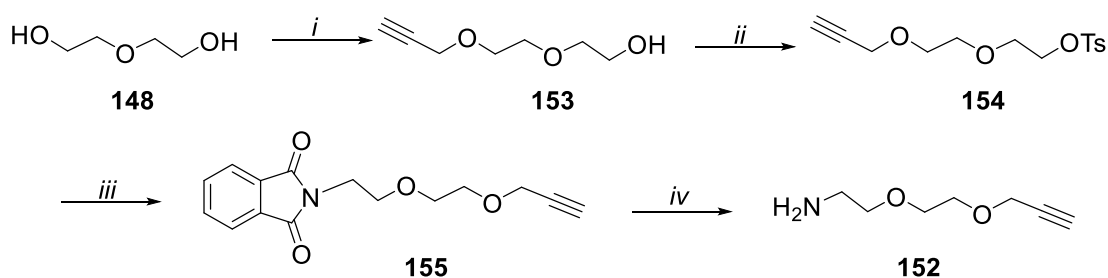

Scheme 43: *i.* Propargyl bromide, NaH, DMF, 77%; *ii.* TsCl, pyridine, 54%; *iii.* Potassium phthalimide, DMF, 93%; *iv.* Hydrazine hydrate, DCM, 91%.

During the hydrazinolysis, we observed the formation of an allyl ether side-product (**156**) together with the main compound **152** (see **Figure 35**), possibly due to transfer hydrogenation.

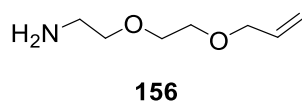

Figure 35: The allyl ether side-product **156** obtained during hydrazinolysis.

This transfer hydrogenation has recently been reported as a new synthetic method but can be avoided by carefully selecting the reaction conditions. It has been found that it is possible to reduce the triple bond of the propargyl group to the corresponding allyl and propyl group. Extended reaction times in combination with large excess of hydrazine hydrate at reflux temperature in ethanol can drive the reaction towards the quantitative formation of the propyl group.¹¹⁶ Thus, several attempts were made to optimise the yield and reduce the formation of the allyl ether side-product **156** (See Table 2). As alcohols are a common solvent for the hydrazinolysis, the first attempt (entry 1) was made using methanol as solvent and two equivalents of hydrazine hydrate. Those conditions gave full conversion after leaving the reaction under reflux overnight, however, 38% of the hydrogen transfer product **156** was formed as well. Anticipating that a non-protic solvent would reduce the hydrogen transfer reaction, diethyl ether tried instead (entries 2-5). The reactions with two equivalents of the hydrazine hydrate gave complete conversion according to NMR after removal of the hydrazone by-product by filtration and subsequent removal of the solvent by rotary evaporation on the trial scale of 25 mg of starting material **155**. However, when scaling up the reaction to 100 mg of **155**, some side product was formed (entries 4 and 5).

For the NMR analysis distinct non-overlapping signals had to be selected. Thus, the aromatic signal at 7.8 ppm for **155** was compared with the combined integral of the allylic methylene groups (5.0-5.2 ppm) for **156** and the CH₂NH₂-triplet of **152** at 2.9 ppm. For all integration errors, an error of about 5% due to human error had to be accepted. The characteristic allylic hedgehog was not selected because the integration error was very large when only small quantities of **156** had been formed.

In order to investigate whether the hydrogen transfer could be further reduced, DCM was trialled. It was clear from initial experiments (entries 6 to 9 and 12 to 15) that using only one or two equivalents of the hydrazine hydrate did not give complete conversion. However, leaving the reaction overnight, produced a similar conversion for the reactions with one and two equivalents of hydrazine hydrate between about 40 to 45% (entries 12 to 15). Heating the reaction to reflux overnight gave a slight increase of the formation of the side product **156** from less than 10% (entries 12 and 14) to above 10% (entries 13 and 15). Increasing the equivalence of hydrazine hydrate to 10 equivalents gave complete conversion of the starting material **155** (entries 10-11 and 16-17) with little difference whether the reaction was left for 4 h or overnight. Also, the hydrogen transfer reaction was fairly well suppressed with less than 10% of it formed according to NMR. This was independent of whether the reaction was stirred at room

temperature or kept under reflux. This reaction was then scaled to 200 mg which was the minimum required for the subsequent steps. Almost full conversion with little side product formation was achieved already after 4 h stirring at room temperature (entry 18) and full conversion was reached overnight (entry 19). Overall, less side product **156** was formed than in the comparing reactions with diethyl ether (entries 4 and 5).

Using these robust reaction conditions, amine **152** was successfully prepared to be used for the following conjugation reactions.

Table 2: The hydrazinolysis was run under different reaction conditions using 25 mg of **155**.

All reactions were monitored by TLC but carried out as overnight reactions in order to achieve complete conversion. For the NMR analysis, the aromatic signal at 7.8 ppm for **155** was compared with the combined integral of the allylic methylene groups (5.0-5.2 ppm) for **156** and the CH₂NH₂-triplet of **152** at 2.9 ppm. There is an integration error (not calculated) when small signals were integrated.

Entry	N ₂ H ₄ ·H ₂ O/ equivalents	155/152/156 ^a	Solvent	Temp	Time
1	2	0/62/38	MeOH	reflux	o/n
2	2	0/100/0	Et ₂ O	rt	4 h
3	2	0/100/0	Et ₂ O	rt	o/n
4 ^b	2	0/89/11	Et ₂ O	rt	4 h
5 ^b	2	0/87/13	Et ₂ O	rt	o/n
6	1	81/13/6	DCM	rt	4 h
7	1	84/8/8	DCM	reflux	4 h
8	2	79/16/5	DCM	rt	4 h
9	2	64/28/8	DCM	reflux	4 h
10	10	0/94/6	DCM	rt	4 h
11	10	0/92/8	DCM	reflux	4 h
12	1	49/42/9	DCM	rt	o/n
13	1	50/37/13	DCM	reflux	o/n
14	2	50/44/6	DCM	rt	o/n
15	2	35/48/17	DCM	reflux	o/n
16	10	0/92/8	DCM	rt	o/n
17	10	0/91/9	DCM	reflux	o/n
18 ^c	10	1/94/5	DCM	rt	4 h
19 ^c	10	0/93/7	DCM	rt	o/n

^aRatio determined by ¹H NMR after removal of the insoluble hydrazone by-product and concentration of the reaction mixture. ^b100 mg scale. ^c200 mg scale.

4.10 Summary

While preparation of the DEG spacer **152** via the Staudinger reaction did not produce analytically pure product, employing a Gabriel synthesis instead gave the bifunctional spacer **152** in 35% over 4 steps. In the latter, cleavage of the phthalimido group was hampered by side product formation due to a hydrogen transfer side reaction. An investigation into the reaction conditions, provided reliable conditions by using 10 equivalents of hydrazine hydrate in dichloromethane. The structure was supported by NMR analysis. However, while the ^1H NMR in CDCl_3 displayed the expected signals (See **Figure 36**), the proton experiment in D_2O lacked the characteristic alkyne proton.

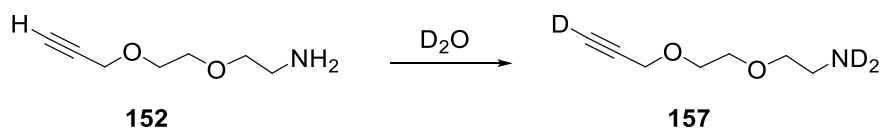

Scheme 44: Possible deuterium-proton exchange of the alkyne proton of **152** in D_2O .

Interestingly, the proton experiment using alcohol spacer **153** is clearly showing the propargyl proton in D_2O (See **Figure 37**). Our only explanation is that in this case a deuterium/proton exchange is happening, although, the pK_a of a propargyl proton at around 24 is not sufficiently acidic to be exchanged in an aqueous medium. We speculate that this might be due to the presence of the amino group assisting in the deprotonation of the propargyl proton.

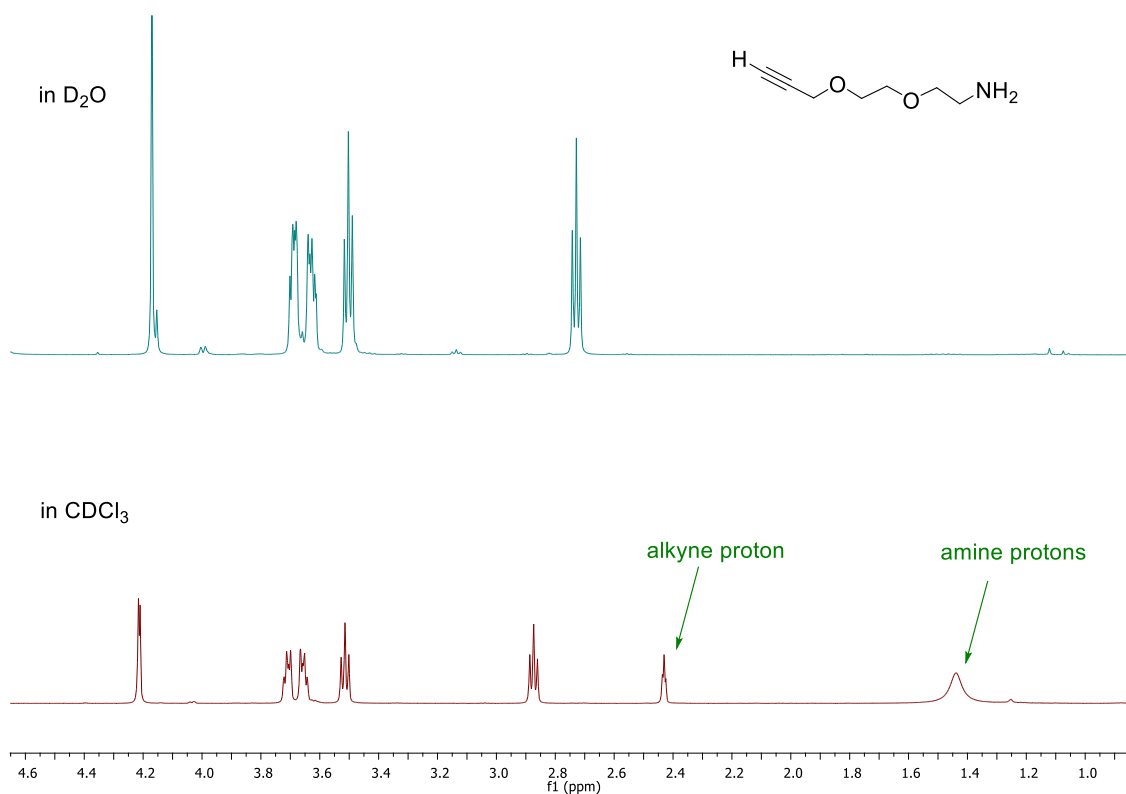

Figure 36: ¹H NMR of compound **152**. The ¹H NMR shows disappearance of the alkyne proton signal in D₂O (top), whereas all signals of this linker were confirmed using CDCl₃ (bottom).

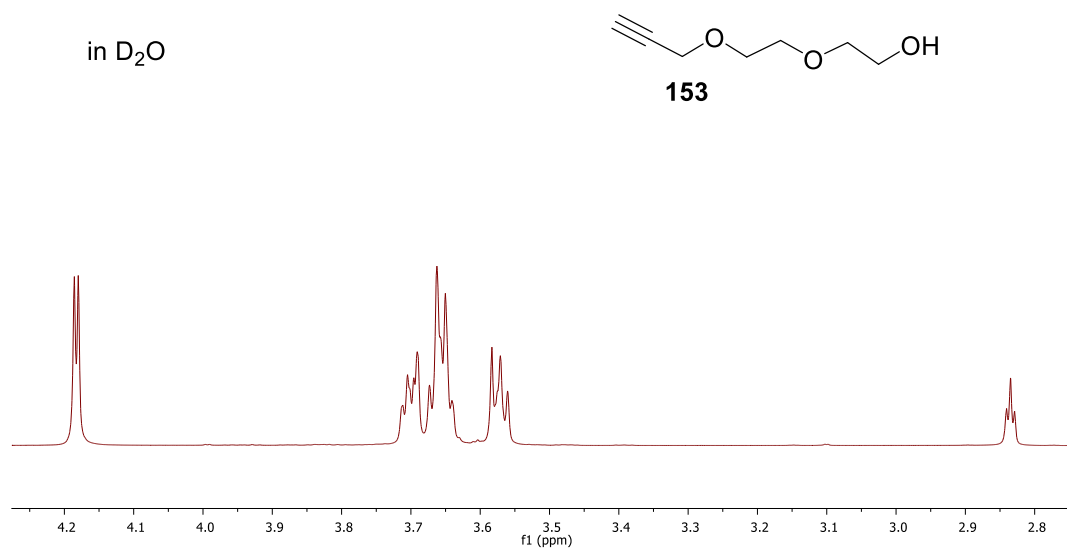

Figure 37: ¹H NMR of compound **153**. The ¹H NMR shows the signal of the alkyne proton in D₂O.

4.11 Hydrogels

Hydrogels are a family of cross-linked hydrophilic polymers capable of absorbing large quantities of water and swell up as a result. In their swollen state, they offer good physical, chemical, and mechanical stability making them fairly resistant to structural change. Their high water content makes them not too dissimilar in many respects to body tissues. Their flexibility, high biocompatibility and biodegradability makes them particularly attractive candidates for biomedical applications such as tissue engineering and drug delivery. These applications can for example serve patients suffering damage or failure of bone tissues by acting as scaffolding or meshing to promote bone regrowth.¹¹⁷

In drug delivery, hydrogels can provide localised and time-controlled delivery of a wide range of drugs and therapeutic agents whilst at the same time dissolving into non-toxic components in the body. The therapeutics delivered in hydrogels range from small to large macromolecules and even whole cell systems have been gel-encapsulated.¹¹⁸

4.11.1 Alginate - General

Alginates are polysaccharides obtained from renewable sources, mainly brown algae.¹¹⁹ Sodium alginate has numerous food related applications due to its gelling properties.¹²⁰ It is also used in many biomedical applications as a hydrogel. Alginates are composed of α -L-guluronate (G block) and β -D-mannuronate (M block) units (**Figure 38**). In order to tune the alginate properties, chemical modification is commonly used. Backbone modification of alginate can increase the stability of hydrogels via the introduction of covalent cross-linkages. Generally, modifications are done at the carboxylic acid group either the D-mannuronate or L-guluronate.¹²¹ For example, the stability of alginate increases via covalent cross-linking through the carboxylate with poly ethylene glycol (PEG). Alginate hydrogels are also formed via coordination to divalent metal cations, e.g. Ca^{2+} . The obtained chelation allows inclusion of water molecules, thus forming gelling bridges of aqueous alginate.¹²²

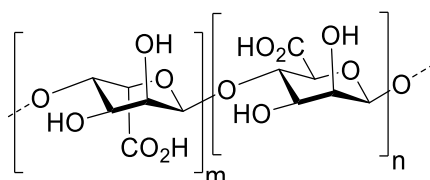
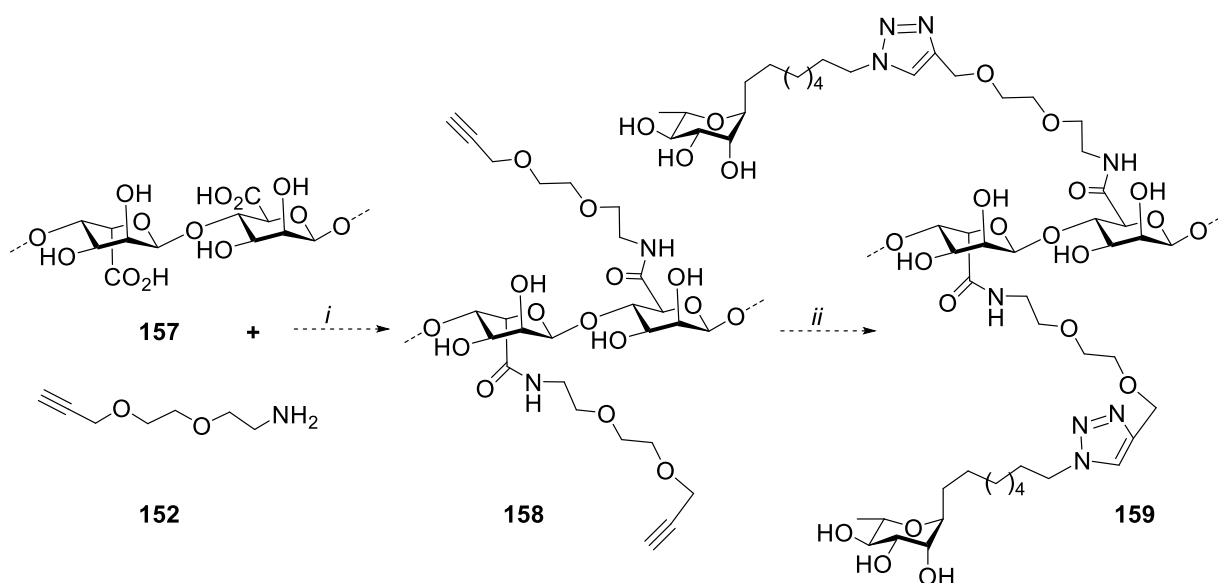

Figure 38: Alginate is a linear copolymer of (1-4) linked β -D-mannuronate (M) and the C-5 is epimer of α -L-guluronate (G).¹²³

For this project, alginates could be used as a carrier for the C-monosaccharide derivatives mimicking the surface of the bladder lining and thus providing multivalent presentation of the pseudo-sugar epitopes. Since the C-glycosidically 8 carbon linker is designed to interact fully with the binding site of FimH, and additional spacer, keeping distance between the carrier and the ligand, is required. For this purpose, the small bifunctional DEG-based linker **152** had been prepared that can link to the alginate via an amide bond and react with the pseudo-sugar epitopes via a click reaction. In the next section, attempts to ligate the linker **152** to alginate are discussed (**158** in **Scheme 45**).

4.11.2 Attempted Synthesis of A Hydrogel

Retrosynthesis for compound **159** suggested alginate **157** and amino linker **152** as possible starting materials. The synthesis of the hydrogel **158** would therefore involve a peptide coupling, followed by a click reaction with the azido pseudo-sugar derivatives (**Scheme 45**).



Scheme 45: The first approach towards synthesis of peptide compound **158**. *i*. EDC, NHS, H₂O (stirring, rt, overnight); *ii*. L-rhamnose **130**, CuSO₄, NaAsc, THF/H₂O, stirring, rt.

The coupling reaction of alginate with the linker **152** using EDC/NHS was attempted under various conditions (**See table 3**). The reaction mixture was left over night for the coupling step

and then dialysed over a period of three days while changing the water twice per day. The dialysed material was freeze dried and the residue subjected to NMR.

Table 3: Ratio of the applied alginate **157** and the spacer **152** as starting materials and the peptide-coupling reagent used.

Entry	Ratio Alginate 157 / Spacer 152	Equiv. EDC/ NHS
1	1:1.5	1.1:0.9
2	1:1	1.1:0.9
3	1:1	0.8:0.8

However, the ^1H NMR analysis of the product was inconclusive and did not confirm that the reaction delivered the desired product. Nevertheless, a click-coupling of L-rhamnoside **130** with the supposedly modified alginate was tried. The ^1H NMR analysis of the obtained material did not show the expected signals for the alginate part of the molecule. It rather suggested coupling between the linker and the L-rhamnosyl moiety occurred, supporting that the previous coupling of conjugating the linker to the alginate in fact failed (**Figure 39**). The sequence was also carried out in reversed order with a model sugar to confirm that the click reaction was working. However, again the conjugation to the alginate failed and had to be abandoned due to time constraints (**Scheme 46**).

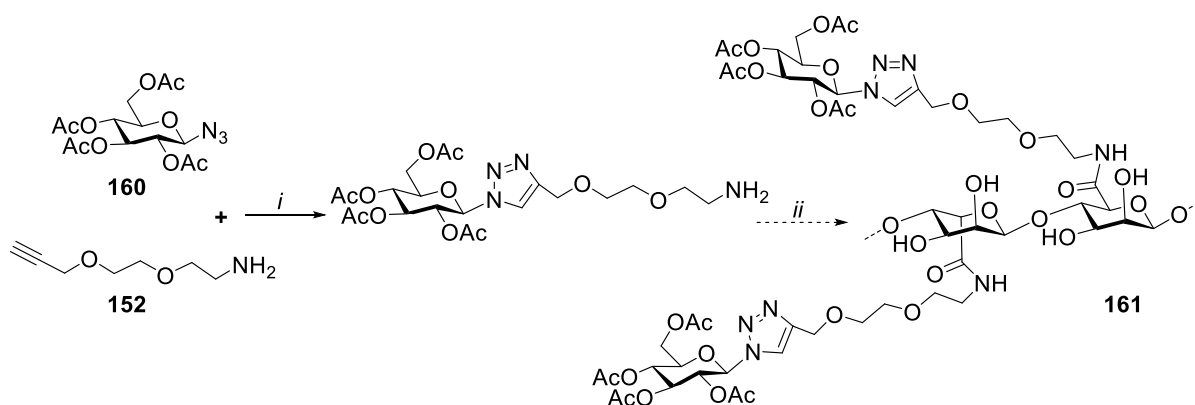

Scheme 46: A model sugar **160** to confirm that the click reaction was working. *i*. CuSO_4 , NaAsc, THF/ H_2O (1:1), stirring, rt., 1h; *ii*. EDC, NHS, H_2O (stirring, rt, overnight).

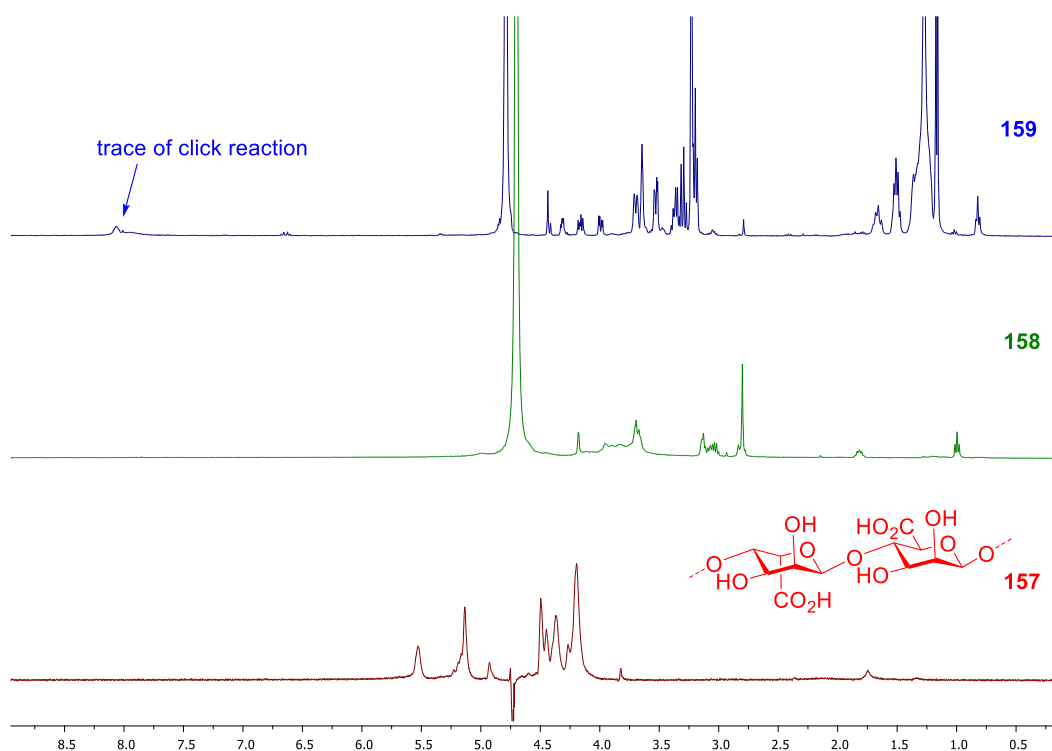
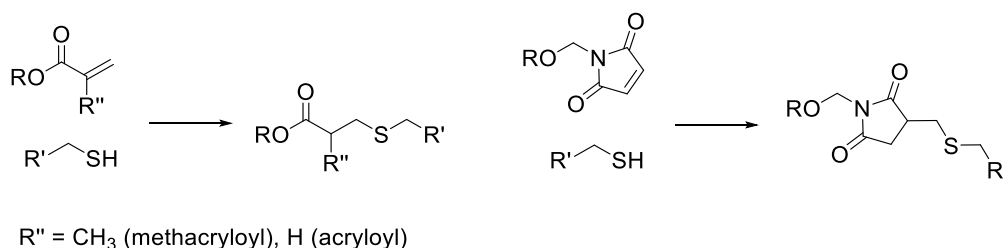

Figure 39: ^1H NMR spectra of compound **159**, **158**, and **157** (run with water suppression) in D_2O at 70°C .

4.12 Summary

Many attempts were made to produce alginate conjugate with linker **152**, the ^1H NMR analysis did not show the expected signals for the desired molecule. Based on the results described above with the alginate, it was decided to trial another route to achieve multivalent presentation of the pseudo sugars. Another type of ‘click chemistry’ is based on reactivity of thiols with alkenes and gold. Thus, the synthesis of a linker containing terminal thiol group was endeavoured. A terminal thiol group reacts both with olefins as in maleimides, acrylates and methacrylates, easily introduced into alginates, and with gold (**Scheme 47**). The latter allowing the synthesis of glyco nanoparticles (GNPs) which contain a metallic core, e.g. gold, surface-coated with an organic material.



Scheme 47: Conjugation by thioether formation.

4.13 Gold Glyconanoparticles

Glyco-gold nanoparticles (GAuNPs) are polyvalent structures that mimic multivalent networks and can interact with receptors in multivalent modes. AuNPs combine an inert inner metal core, e.g. gold, that is covered with a layer of spacers to which the biological interesting such as carbohydrate epitopes are attached (**Figure 40**). There are various ways to produce GAuNPs. The overall process depends on self-assembling, e.g. by mixing thiol-terminated glycoconjugates with gold nanoparticles under reductive conditions.¹²⁴

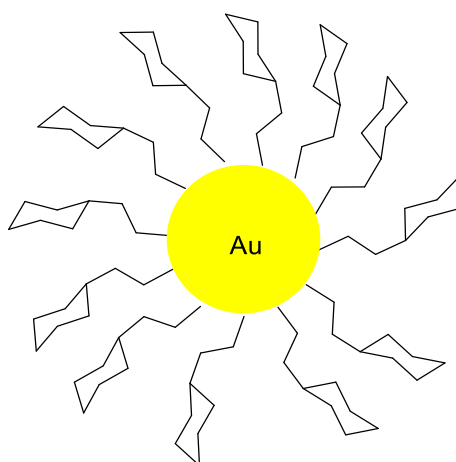

Figure 40: A schematic representation of a glyco-gold nanoparticle.¹²⁴

The design of AuNPs depends on many factors including the application for which they are to be used. AuNPs are widely used for biomedical applications where the size and the shape of the particles and the length and type (e.g. hydrophilic, hydrophobic) of the linker are influenced by the exact application. Three structures of AuNPs can be used (sphere, rod and star) differing in their biophysical properties. As an example, *E.coli* has exhibited a great avidity and sensitivity towards rod shaped mannose-AuNPs when analysing the surface interaction. This is advantageous for inhibiting binding of *E.coli*.^{125,126}

4.13.1 Synthetic Pathway of Gold Nanoparticles

In order to evaluate the multivalent binding affinities of the designed *C*-glycoside compounds and possibly for diagnostic purposes, the conjugation to AuNPs was envisioned. For this purpose, an additional linker had to be introduced containing a terminal thio group for conjugation to the AuNPs (**Figure 41**).

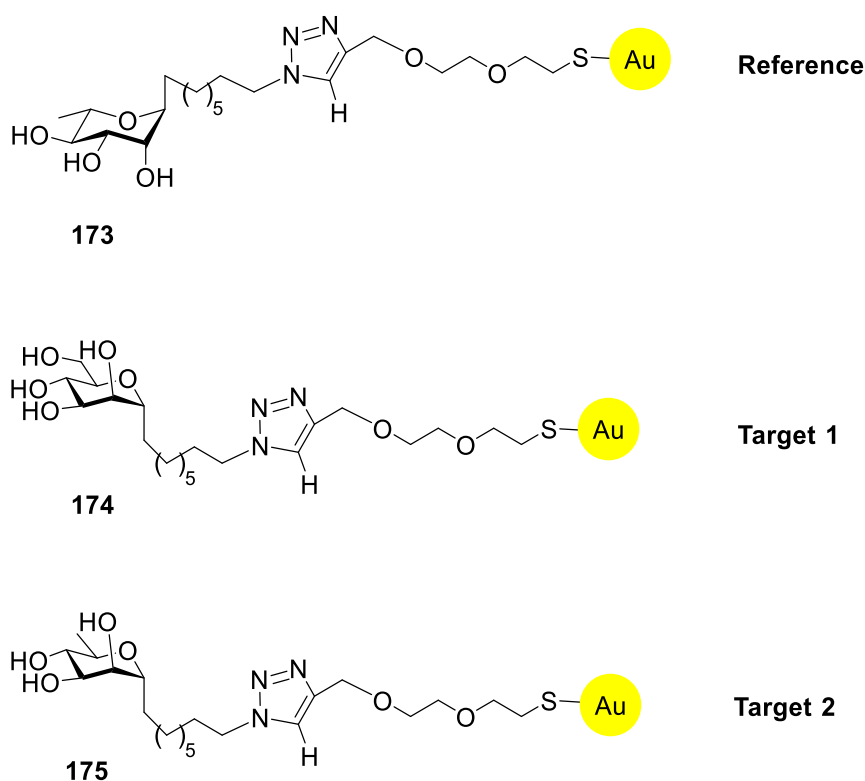
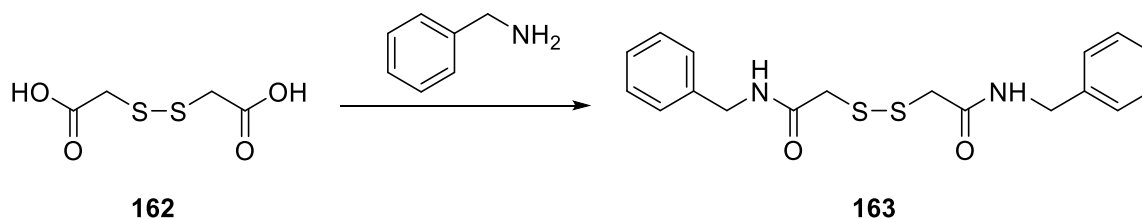

Figure 41: The three synthesised GNP structure types.

4.14 Synthesis of The Thio-Spacer

Several approaches were taken in order to produce a suitable linker. Dithiodiacetic acid **162** was used in the first attempt producing two units of C-2 linked thiols¹²⁷

As a model reaction, in order to find suitable reaction conditions, the diacid **162** was reacted with benzyl amine under a range of conditions (**Scheme 48, table 4**).



Scheme 48: The coupling reaction of dithiodiacetic acid **162** with benzyl amine.

Table 4: The coupling reaction of dithiodiacetic acid with benzyl amine under differing conditions.

Entry	BnNH ₂ /RCO ₂ H	Reagents	Equiv.	Solvents	Yield
1	2:1	EDC/DMAP	2:2	H ₂ O	-
2	2:1	EDC/Pyridine	2:2	Pyridine	-
3	2:1	EDC/NHS	2:2	H ₂ O	-
4	2:1	EDC/NHS	2:2	DMF	-
5	2:1	EDC/HOBt	2:2	Pyridine	-
6	2:1	HOBt/DCC	6:6	DMF	-
7	2:1	CDI	3	DMF	11%
8	2:1	CDI	3	THF	14%
9	2:1	SOCl ₂	4	DCM/DMF 10:1	50%

EDC, a common reagent for the amide bond formation with a carboxylic acid, was trialled (**table 4**, entry 1-2) with different bases and solvents but did not produce any desired product **163**. Neither did the addition of a second coupling reagent to improve the reaction (**table 4**, entry 3-5) work. Also, combining HOBt/DCC,¹²⁸ another classic peptide coupling reagent, did not work (entry 6). However, changing the coupling reagent from EDC to CDI (**table 4**, entry 7 and 8) provided the expected amide but in very low yields (11-14%). Using thionyl chloride instead, gave a moderate yield of **163** (**table 4**, entry 9, 50% yield). This yield is in line with a published yield for this reaction of 52%.¹²⁹ However, those reaction conditions would not be suitable for the *C*-glycoside compounds. Thus, using thionyl chloride with amino L-rhamnose **164** and diacid **162** (**Scheme 49**, **table 5**) was unsuccessful, while employing the EDC mediated amide formation gave an amide product in a poor yield (15% yield) and inconclusive NMR data.

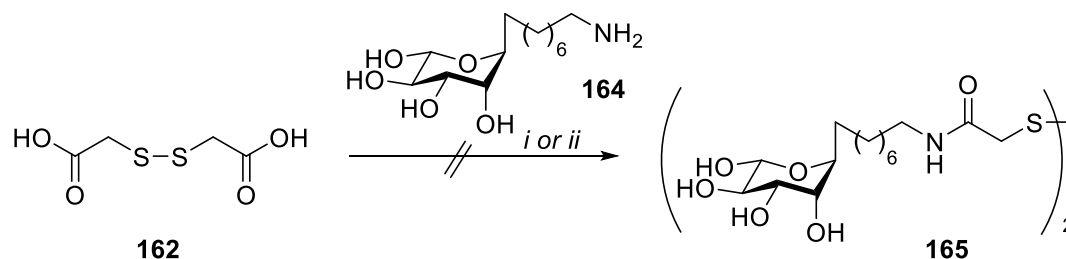

Scheme 49: Formation of amide bond via *i*. EDC, NHS, H₂O, overnight. *ii*. SOCl₂, DMF, DCM, reflux 3h, 0 °C. → r.t., no product formation

Table 5: The coupling reaction of dithiodiacetic acid with amino-L-rhamnoside.

Amino-L-rha.	Reagents	Equiv.	Solvents	Yield
1	EDC/NHS	2:2	H ₂ O	15%
2	SOCl ₂	2	DCM/DMF 10:1	-

Since amide formation under those conditions has been reported many times, another amine was trialled. Thus, diacid **162** was dissolved in THF, then DCC and HOBt were added. After formation of the white urea precipitate, propargyl amine was added to the reaction mixture. The reaction was monitored by TLC and showed only one spot after full conversion. In the first attempt, the reaction was left overnight. However, the ¹H NMR suggested that two compounds with the same R_f values (in the chromatographic systems tested) had been formed in a 1:1 ratio. Reducing the reaction time to 3h, favoured the formation of the desired product **166** (ratio **166/167 2:1**), while shorter reaction times did not lead to full conversion (**Figure 42**). The side product showed similar signals in the NMR spectrum but differed in the shift and integrals. While the desired product **166** gave the expected 1:2:2 ratio for the integrals, the side product produced a ratio of 0.5:1:2. This led to the assumption that the 1,3-dioxoazacyclo **167**¹³⁰ had been formed as well. Unfortunately, it was difficult to isolate product **166** from **167** despite several attempts (**Scheme 50**).

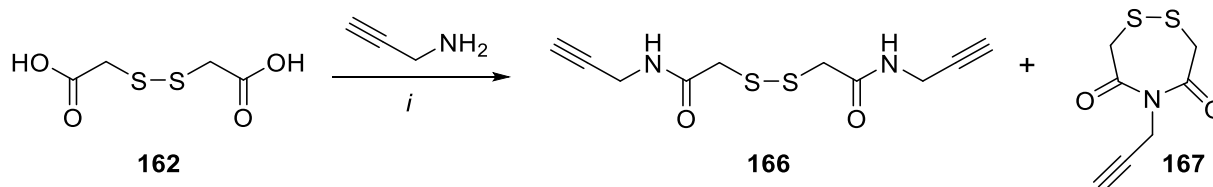

Scheme 50: The reaction of dithiodiacetic acid with propargyl amine which accompanied by the 1,3-dioxoazacyclo. *i*. HOBt, DCC, THF, r.t, 3h, 96% (two products).

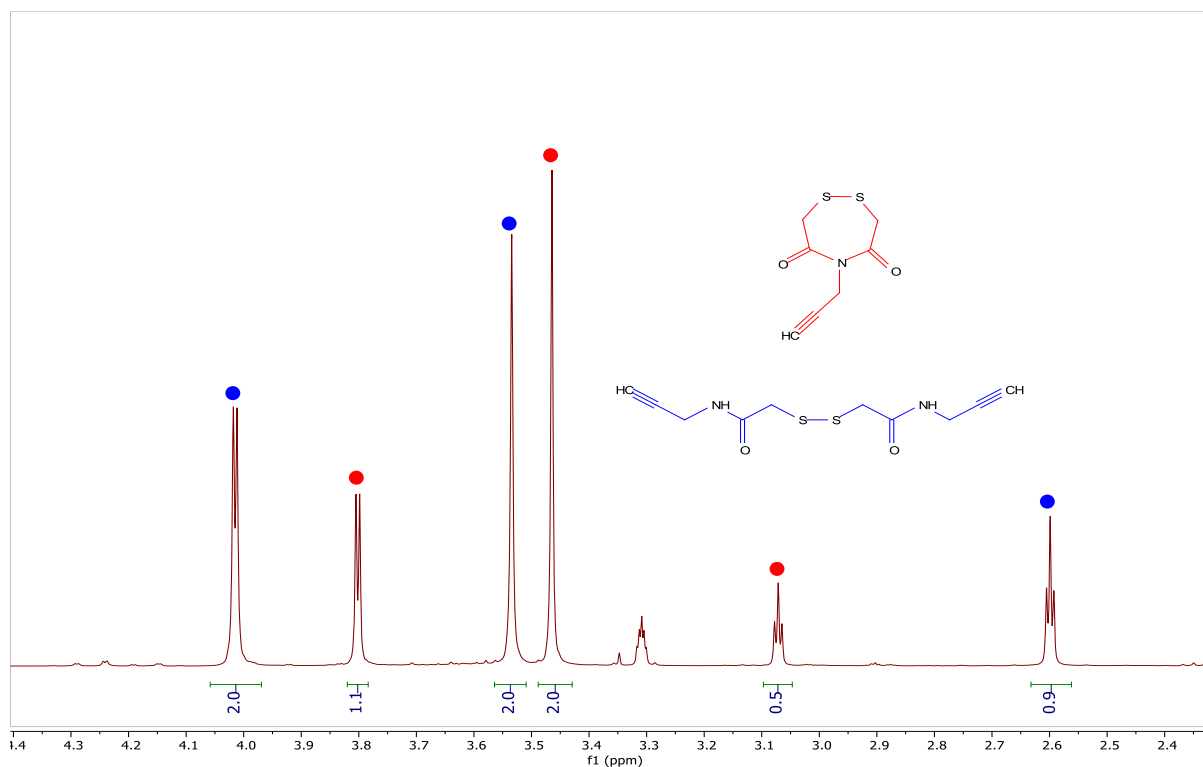
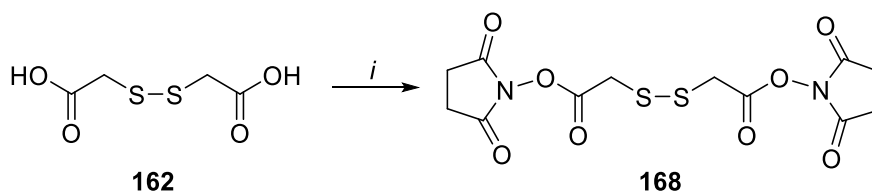

Figure 42: ¹H NMR shows two compounds.

A last attempt using the disulphide linker was made by preparing the active ester **168** (Scheme 51).¹³¹



Scheme 51: Synthesis of the active ester intermediate. *i*. NHS, DCC, DCM/(CH₃)₂CO, stirring overnight at r.t., 80% yield.

After obtaining the intermediate compound **168** in good yield (80%), coupling **168** with amino-L-rhamnose **164** using diisopropylamine¹³¹ was attempted but did not give any amide containing product (**Scheme 52**). After these failed results, this route was abandoned.

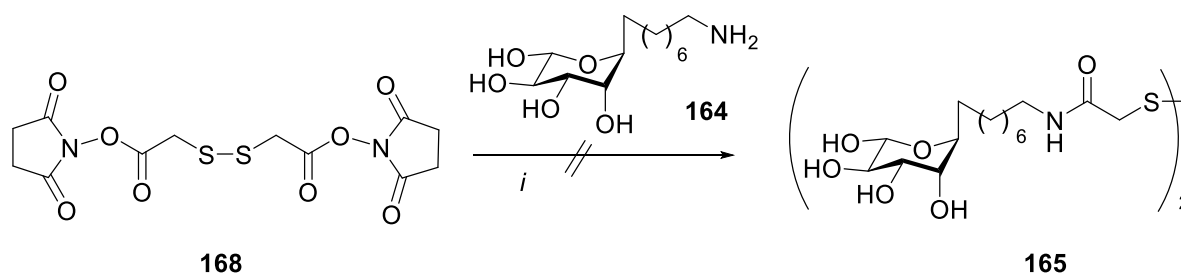

Scheme 52: Coupling attempt using the activated ester to form amide compound **165**. *i.* diisopropyl amine, DMF, overnight at room temperature.

As an alternative to the diacid **162**, 4-pentynoic acid was believed to be a good choice as conjugation linker between the pseudosugar epitope and the carrier because it offered two functional groups suitable for the planned chemistry: an alkyne group which could be used for click reaction with the pseudo sugar molecules and a carboxylic group for amide bond formation either directly with the carrier or with, e.g., allyl amine (**Scheme 53**). Using allyl amine allows to expand the conjugation chemistry because a thiol-ene click reaction giving thioethers could be carried out. This type of reactions has been widely applied to bioconjugate systems such as the delivery and release of therapeutics.¹³²

Allyl amine was thus reacted with 4-pentynoic acid **169** using HOBt and DCC in DCM. The unsaturated compound **170** was successfully synthesised in a good yield of 80% (**Scheme 53**). The next step was to then introduce a thio group using thiocresol as reagent. In order to trial the thiol-ene click reaction, thiocresol and thioacetic acid were used together with azobisisobutyronitrile (AIBN) under several conditions (**Scheme 53**).¹³³ Unfortunately, no desired product could be identified and isolated from those attempts despite using different equivalents of thio-compound during this reaction (**See Table 6**).

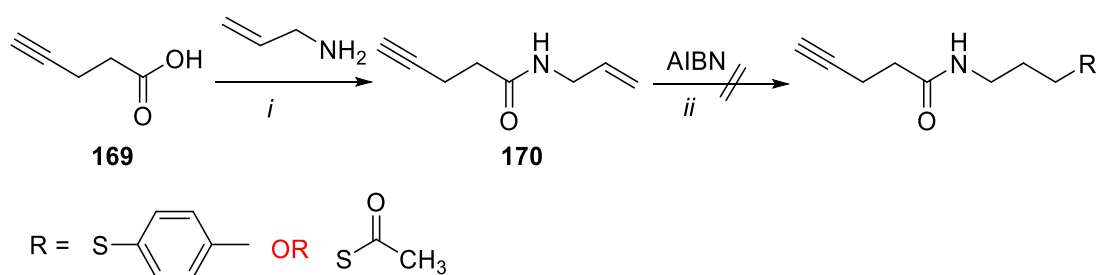

Scheme 53: Formation of peptide bond and thiol-ene reaction. *i.* HOBt, DCC, DCM, r.t, 1h, 80%; *ii.* *p*-thiocresol OR thio acetic acid, AIBN, THF, reflux.^{134,115}

Table 6: The thiol-ene click reaction using 0.1 eq. AIBN under different equivalents of thio-compound

Thio-compounds	Equiv.	Solvents	Conditions	Yield
Thiocresol	5	THF	Reflux 2h	-
	6	CH ₃ OH	Reflux overnight	-
	10	THF	Reflux overnight	-
Thioacetic acid	15	Dioxane	Reflux 2h	-
	10	THF	Reflux overnight	-

Due to these failed results also of the thiol-ene coupling reaction, the thioacetic acid was tried with the previously discussed intermediate compound **154** (see **Chapter 4, section 4.9.2**) for obtaining the required spacer using thioacetic acid or potassium thioacetate (**Scheme 54**).^{135,136}

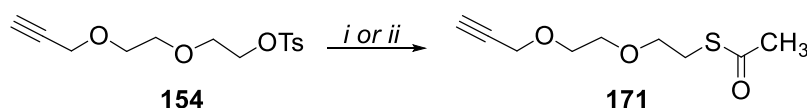

Scheme 54: Alternative synthetic pathway for the spacer **171**. *i.* thioacetic acid, Et₃N, DMF, overnight, 84%. *ii.* potassium thioacetate, DMF, 2h, 90%.

Both treatment of compound **154** with thioacetic acid or potassium thioacetate produced the desired bifunctional spacer **171** in good yields. *In situ* cleavage of the thioacetate group allows easy access to our desired route using gold nanoparticles and click reaction with our target pseudosugars.

4.15 Click Chemistry Including Copper Mediated Click Reactions (CuAAC)

‘Click chemistry’ is a relatively new approach in organic synthesis. This concept was introduced in 2001 by Sharpless and co-workers.¹³⁷ This reaction type can be applied in different fields of Science such as biological applications, e.g., for introducing detection or tracing labels on bio molecules.¹³⁸ The advantages of this type of reactions are that they generally do not require sophisticated reaction conditions as inert atmosphere and dry conditions (i), they need no or only very simple purification steps as filtration (ii), and they are often very fast and high

yielding reactions (iii). Many times, those reactions can be carried out in water or buffer solutions as reaction solvent.

The most common click reaction is the coupling of an azide functionalized compound with a terminal alkyne compound to produce a 1,2,3-triazole in an aqueous system under Cu(I) catalysis (**Scheme 55**).^{139,140} Discovered by Huisgen, the triazole formation was originally performed at elevated temperature in the presence of Cu(0). This 1,3-dipolar cycloaddition produced generally two isomers, the 1,4- and the 1,5-substituted products.¹³⁹ The by Sharpless and Meldal¹³⁷ introduced variation produces only the 1,4-substituted triazole and is dependent on the presence of an appropriate catalyst e.g. transition-metal ions such as Cu(I) and moves the reaction mechanism from a concerted cycloaddition to a step-wise mechanism via an intermediate copper acetylene, which isolated is an extremely hazardous species.¹⁴¹

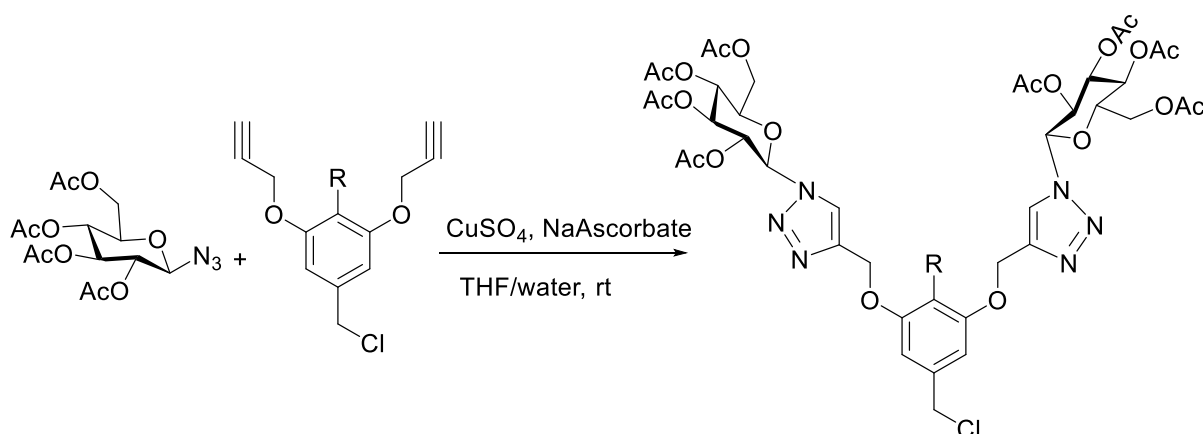

Scheme 55: Example explains formation of 1,2,3-triazole using the water as a solvent.

4.15.1 Synthesis of 1,2,3-Triazole Compounds

After having successfully synthesised the spacer **171**, the next step was to find suitable conditions to link it to the pseudo sugars **130**, **133**, and **136**.

The click coupling was attempted between azido-L-rhamnose **130** and compound **152** (**Scheme 56**). There several ways to introduce the catalytic Cu(I). In some cases Cu(I)Br is used, e.g. as [CuBr(PPh₃)₃].¹⁴² A common option is to produce the Cu(I) species *in situ* by adding both copper (II) sulphate and sodium ascorbate to the reaction mixture and was used for the click reactions discussed here.

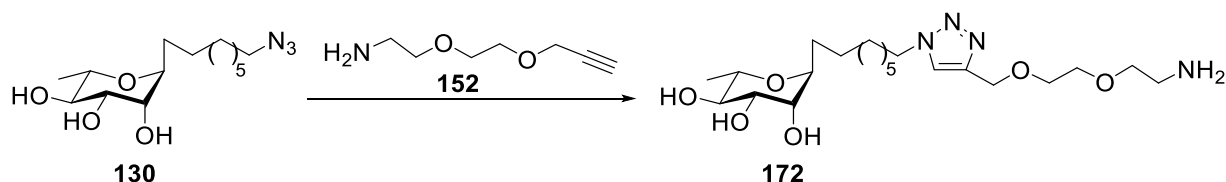

Scheme 56: The click reaction of the compound **130** with the linker **152** using CuSO_4 and sodium ascorbate.

Table 7: The click reaction using different equivalents of starting materials and catalysts.

Entry	Ratio azide-alkyne (130-152)	Equivalents CuSO_4 -Na-ascorbate	Ratio of solvents	Conditions	Yield
1	1:2	1:5	THF/ H_2O 1:1	r.t, 1h	20%
2	1:4	1:3	^t ButOH/ H_2O 1:1	45°C, 2h	15%
3	1:1.5	1:4	DMF/ H_2O 9:1	r.t, 1h	80%

The click reaction was first trialled under a range of reaction conditions with model systems (reported in **Chapter 7**) and the best reaction conditions (See **Table 7**) applied to one of the target pseudo sugars and spacer **171**.

While entry 1 and 2 did not produce any satisfactory yields, entry 3, using only a 1.5 equivalent excess of the spacer **152** and 4 equivalents of sodium ascorbate in a DMF/ H_2O 9:1 solvent mixture was effective at the formation of the click compound **172** (80%). In order to obtain good conversion, it was important to produce three different solutions, the starting materials in DMF, one aqueous copper sulfate and one aqueous sodium ascorbate solution. Next the copper sulfate solution was added to the solution of the starting materials before eventually addition the reducing agent sodium ascorbate to initiate the reaction.

Following this approach, the pseudo D-mannose **133**, pseudo D-rhamnose **136** and pseudo L-rhamnose **130** were reacted with the spacer **171** to obtain the final target triazoles in good yields (**Scheme 57**).

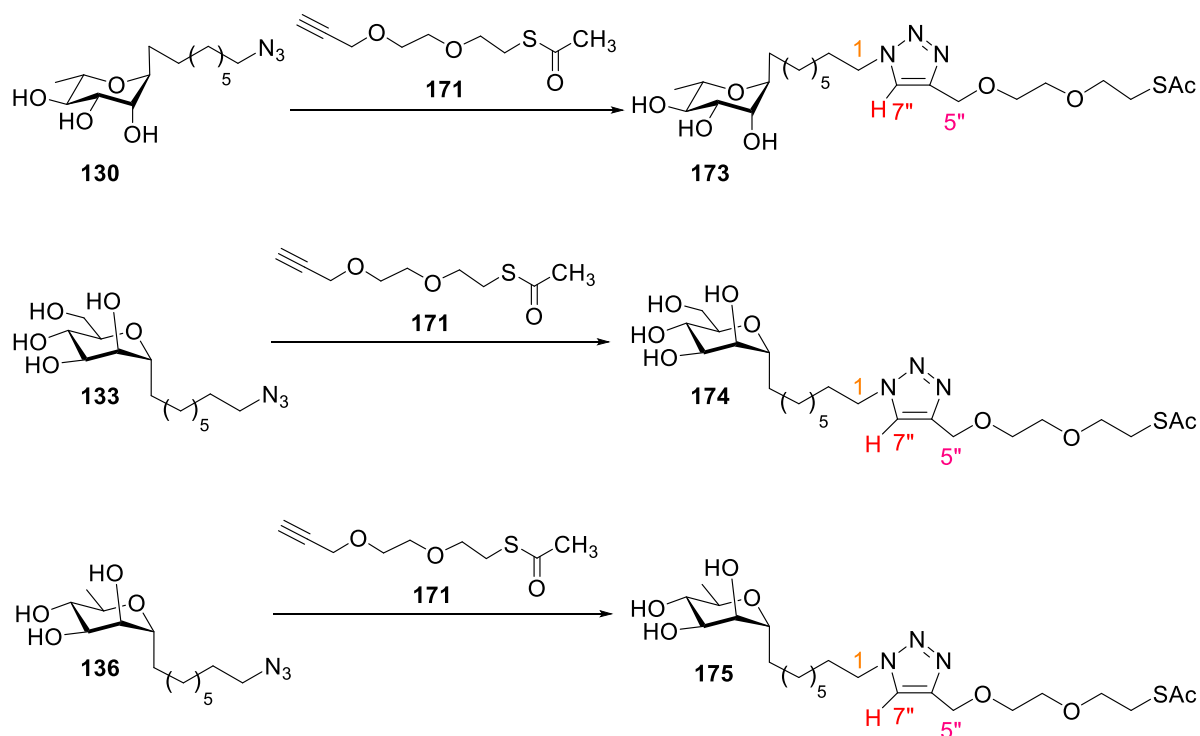

Scheme 57: the general method of click reaction for all azido-sugars with the spacer using CuSO_4 and Na-ascorbate.

Pseudo L-rhamnose **173** and pseudo D-rhamnose **175** were obtained in yields of 85% and 94% respectively, whereas the only 64% yield for D-mannose **174** were obtained. Due to time constraints, the reaction could not be repeated but the low yield is possibly due to material loss in aqueous phase. Attempts to retrieve product **174** from the aqueous phase were not successful. ^1H NMR experiments confirmed that the expected products **173**, **174** and **175** had been obtained. The methylene protons next to the azide group prior to the click reaction appear around 3.3 ppm. After click reaction, the triplet of the $-\text{CH}_2-\text{N}_3$ shifts from about 3.3 ppm to 4.4 ppm. Also, the doublet from the methylene group next to the acetylene group in the spacer **171** shifted from 4.2 ppm to 4.6 ppm in the product. The indicative acetylene proton signal, the triplet at 2.4 ppm, disappeared in the ^1H NMR and instead a singlet at 7.97 ppm appeared conforming to the single proton in the triazole ring (**Figure 43**).

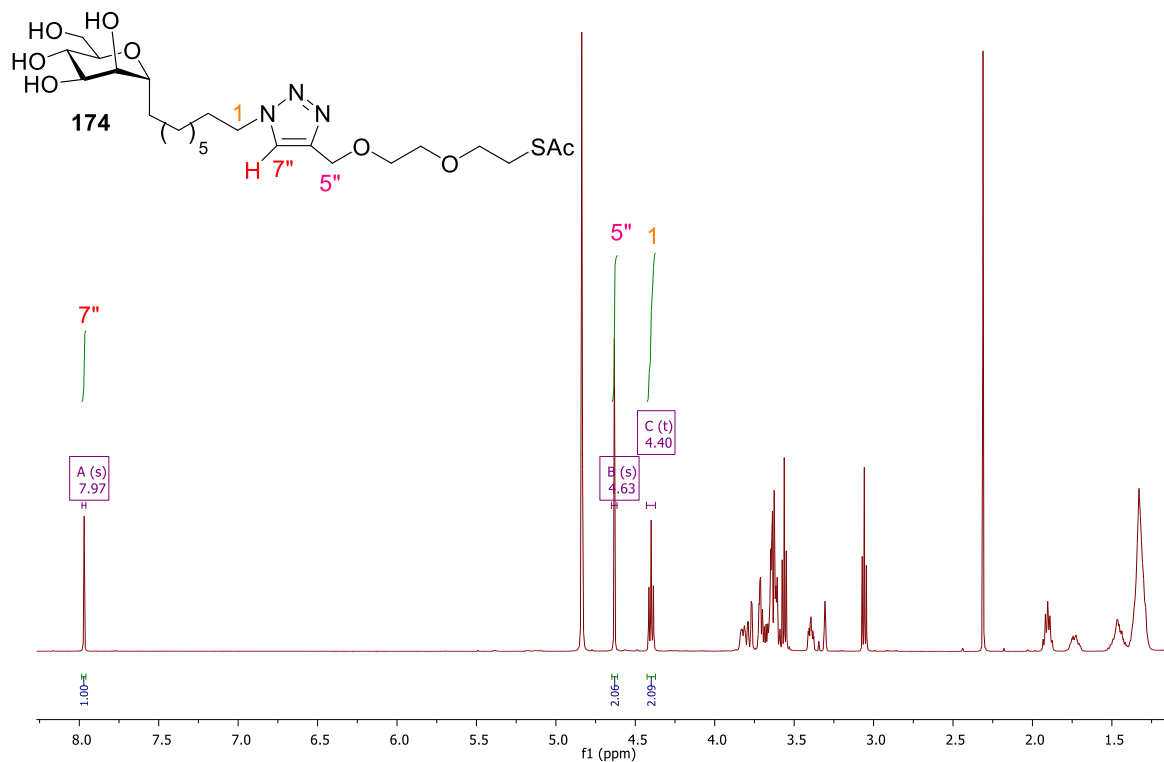

Figure 43: ^1H NMR of compound **174** shows the signal of triazole at 7.97 ppm.

4.16 Summary

The U.V. active compounds **173**, **174** and **175** have been successfully synthesised and their structures confirmed by NMR, optical rotation and MS.

In collaboration, these compounds will be conjugated to scaffolds and to gold nanoparticles in order to obtain multivalency. Due to the multivalent appearance of FimH on the bacteria,¹⁴³ the binding affinity could be increased by the multivalent presentation.

CHAPTER 5

Conclusions and Future Work

In this project novel compounds of **C-glycosides** with 8 carbon atoms at anomeric centre have been successfully synthesised.

5.1 Conclusions

The key of this project is the synthesis of **C-glycosides** of α -L-**C**-rhamnose, α -D-**C**-mannose and α -D-**C**-rhamnose (**Figure 5.1**), these intermediates have been successfully achieved in good yields using 4 steps starting from commercially available materials. The synthesis started with acetylation, allylation, deacetylation and then benzylation for α -L-**C**-rhamnose and α -D-**C**-mannose with an overall yield of 53% and 68% respectively. The novel **C-glycoside** of α -D-**C**-rhamnose was also prepared from the commercially available methyl α -D-**C**-mannoside via two pathways. The first method involved 6 steps while the second method involved 4 steps. Replacement of the secondary hydroxyl group with iodo group gave poor yield. Thus, tosylation was more efficient. The direct reduction of the unprotected tosylate in the second route, produced a higher total yield (45%) than the route via employing a temporary silyl ether protecting group (total yield 14%). NMR analysis confirmed the formation of the **C-glycosides** and with these results, **C-glycopyranoses** are in hand.

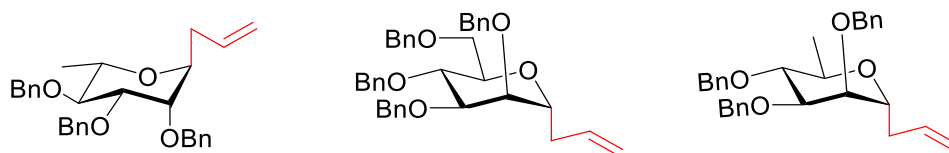

Figure 5.1: **C-glycopyranose** of α -L-**C**-rhamnose, α -D-**C**-mannose and α -D-**C**-rhamnose.

Synthetic methodologies to introduce an alkyl chain on the pseudo anomeric centre of **C-glycosides** were applied via two methods (Wittig coupling and cross metathesis).

Cross-metathesis reactions were performed with Grubb's 1st and 2nd generation catalyst to optimise the yield of desired coupling product of **C**-mannose, which reacted with the commercial

alkene, hept-6-en-1-ol. The ruthenium 2nd generation was then used as catalyst in reactions of CM for all **C-glycosides** due to the higher yield relative to the ruthenium catalyst 1st generation. The TLC of this reaction showed only one spot after chromatography; however, NMR data indicated a mixture. It was assumed that these signals might originate from the *E/Z* isomeric mixture combined with remaining small amounts of catalyst. Unfortunately, NMR data still suggested the presence of a mixture of compounds. Careful NMR analysis suggested the loss of one carbon in the chain of the linker and is the product of a possible side product of the cross metathesis.

Thus, as an alternative a pathway employing a Wittig reaction for the chain extension was pursued.

Oxidation was achieved in high yields for **C-glycosides** and iodo Wittig salt was used for the successful Wittig coupling. The target compounds have been successfully synthesised and their structures confirmed by NMR spectrum. The **C-glycoside** target molecules of the azide compounds were synthesised in 13 steps for L-rhamnose and D-mannose (total yield is 5% in each case), while D-rhamnose required either 15 steps giving a total yield of 2% or 10 steps with an overall yield of 5% when using the direct reduction pathway (**Figure 5.2**).

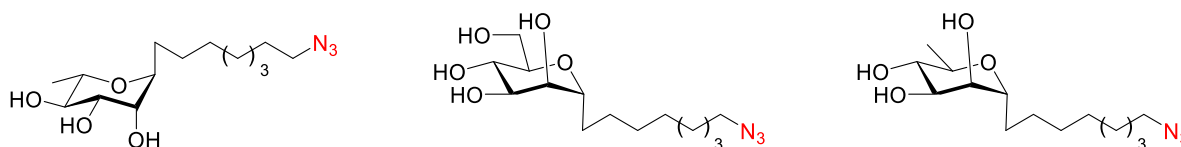

Figure 5.2: The target of **C-glycosides** with a handle group.

For further conjugation of the target compounds to a carrier, a bifunctional linker was required. The preparation of the DEG spacer via the Staudinger reaction did not produce analytically pure product but employing a Gabriel synthesis instead gave the bifunctional spacer over 4 steps. In the latter, cleavage of the phthalimido group was hampered by side product formation due to a hydrogen transfer side reaction. An investigation into the reaction conditions, provided reliable conditions by using 10 equivalents of hydrazine hydrate in dichloromethane and gave the spacer in good yield.

The prepared spacer from diethylglycol was attempted several times under various conditions to link with alginate by amide bond. Unfortunately, all attempts to link a carrier with alginate have so far been unsuccessful. Thus, the spacer was modified into a thio-spacer which

was successfully linked with the target molecules in using click reaction conditions (**Figure 5.3**).

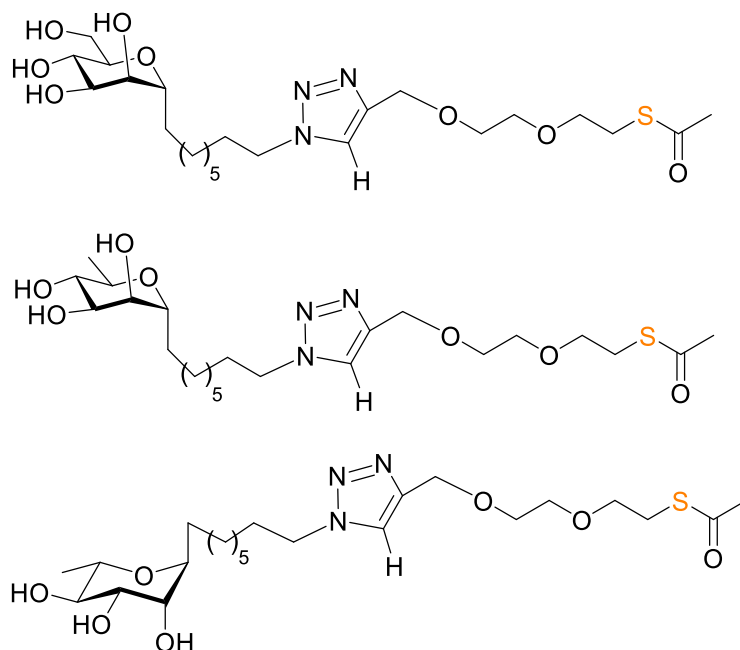

Figure 5.3: The target of **C-glycosides** with a thio group.

These U.V. active compounds have been successfully synthesised and their structures confirmed by NMR, optical rotation and MS.

5.2 Future Work

5.2.1 Synthesis of Multivalent of C-glycosides via Nanoparticles

The prepared compounds will be conjugated to scaffolds and to gold nanoparticles in order to obtain multivalency. Due to the multivalent appearance of FimH on the bacteria, the binding affinity could be increased by the multivalent presentation (**Figure 5.4**).

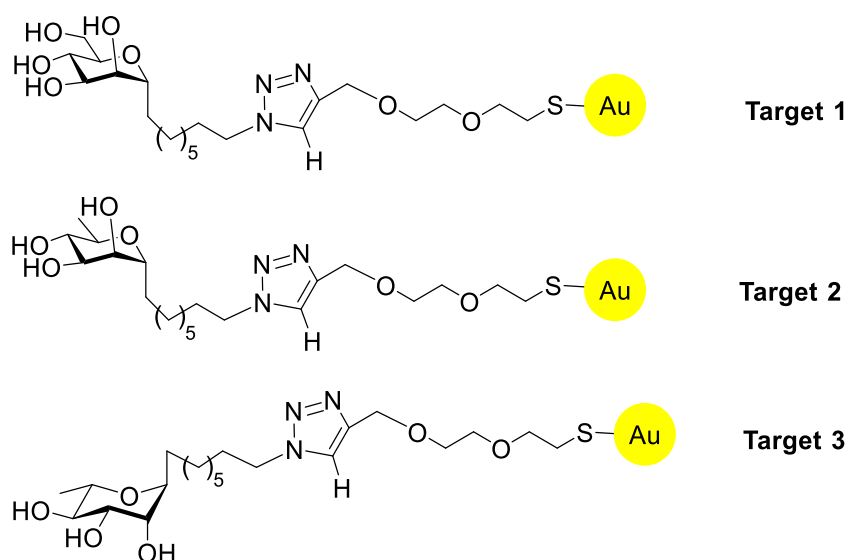

Figure 5.4: The targets with gold nano-particles.

5.3 Suggestions

5.3.1 Synthesis of Wittig Salt With A Linker of Aldehyde

C-glycosides could also be synthesised by other methods than a Hosomi-Sakurai reaction to introduce alkyl chains with different chain lengths. For example, acetyl **A** could be reacted with various potassium fluoro borates to give alkenyl-**C-glycosides B** with different chain lengths. Hydrogenation under mild conditions of the triple bond would then provide the desired alkyl-**C-glycosides C**.

On the other hand, nitrile **D**, which would prepare from compound **A**, could be hydrolysed to the carbonic acid **E** which, in turn, could be reduced to alcohol **F** with a strong reducing agent. This alcohol could subsequently be converted via a Garegg iodination to the known Wittig salt **H** (see Scheme 5.A).

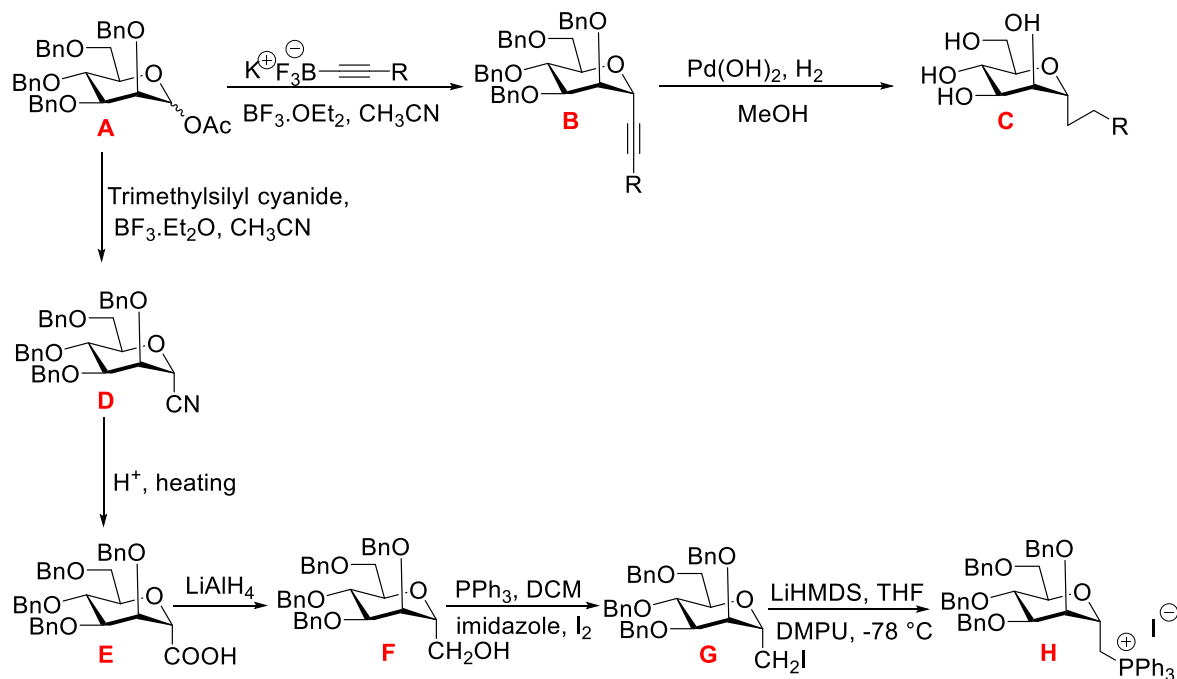

Scheme 5.A: Suggested synthetic route to Wittig salt **OR** coupling a Wittig salt **H** as coupling partner with a linker of aldehyde **I** (see **Scheme 5.B**).

Instead of using the azide as a terminal group discussed in this thesis, one could introduce a thio acetate into the linker which would allow direct conjugation to, e.g., a gold surface. However, the distance between the sugar epitope and the surface might be small in order to achieve good recognition or binding of the FimH. (see **Scheme 5.B**).

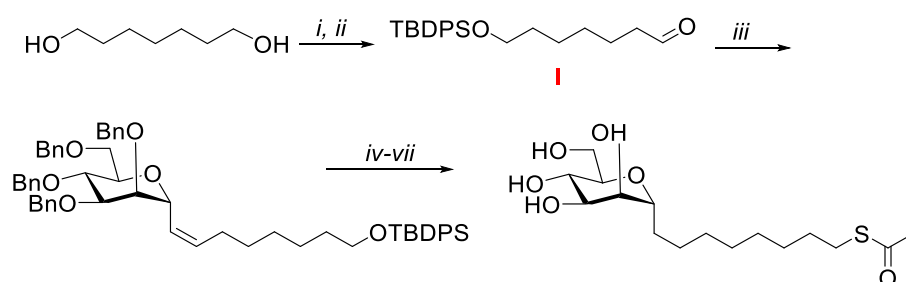

Scheme 5.B: Suggested synthetic route for Wittig coupling and a direct introduction of a thio acetate group. i. $TBDPSCl$, $DIPEA$, DMF , overnight, rt ; ii. Cr_2O_3 , H_2SO_4 , H_2O ; iii. **H**, $LiHMDS$, THF , $DMPU$, $-78^\circ C$; iv. $TBAF$, THF , rt ; v. $TsCl$, $pyridine$, rt ; vi. potassium thioacetate, DMF , rt ; vii. $Pd(OH)_2/C$, $EtOAc/MeOH(1:1)$, rt .

CHAPTER 6

EXPERIMENTAL

6.1 General Procedures

All reagents (Sigma-Aldrich, Acros Organics, and Fisher Scientific) were used as received, and run in purified solvents using glassware which was dried by heat provided by a heat gun, while being flushed by stream of dry nitrogen. Reactions were monitored by Thin layer chromatography (TLC). TLC was done using pre-coated Merck aluminium TLC-plates (silica gel 60 F254). Spots were visualized by UV light (254 nm) and by charring with a vanillin staining solution (1 g vanillin, 20 mL acetic acid, 200 mL MeOH, 10 mL conc. H₂SO₄). Column chromatography was carried out on silica gel (VWR Chemicals, 40-63 μ m). Anhydrous MgSO₄ was used to dry organic phases from extractions followed by concentration under reduced pressure at 45 °C (temperature of water bath). ¹H and ¹³C NMR spectra were recorded in CDCl₃ or CD₃OD₃ if not otherwise stated on a Bruker Avance III 400 MHz UltraShield Plus spectrometer or on a Bruker Avance-III 500 MHz Bruker spectrometer with tetramethylsilane as internal standard whenever available. NMR signal assignments are based on ¹H, ¹H-COSY, DEPTQ, HSQC and HMBC experiments. NMR spectra were referenced against the following TMS unless stated otherwise: CDCl₃, ¹H NMR, δ_{H} 7.260 ppm and ¹³C NMR, δ_{C} 77.160 ppm; CD₃OD, ¹H NMR, δ_{H} 3.31 ppm and ¹³C NMR, δ_{C} 49.000 ppm. All *J* couplings are given in Hz. Electrospray ionisation mass spectrometry (ESI) was performed with a Thermo Fisher Orbitrap Q Exactive Plus high-resolution mass spectrometer. The analyses were done in positive ionisation mode by direct injection to the source. Optical rotations were determined at a wavelength of 589.3 nm (sodium D line) using a 1 mL (0.25 dm) quartz cell with the Bellingham + Stanley ADP440 digital polarimeter at ambient temperature. OR values are stated in degrees.

Ozone for ozonolysis reactions was generated with the ozone generator COM-AD-01 from Anseros Ltd. set to 4 g O₃ per hour at a flowrate of 100 litres per hour. Excess ozone passing the reaction vessel was destroyed with a sodium thiosulfate / potassium iodide solution.

6.2 Experimentals for Individual Compounds

6.2.1 Methyl L-rhamnopyranoside **90**¹⁴⁴ (Route 1)

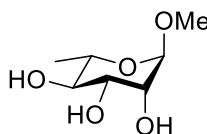

Methyl L-rhamnopyranoside **90** was prepared according to a published procedure, thus, monohydrate **89** (1 eq, 300 mg, 1.83 mmol) was dissolved in methanol (5 ml) followed by addition of Amberlite® (IR-120) resin (150 mg). The stirred reaction mixture was kept under reflux and monitored by TLC (DCM/MeOH 10:1) overnight. After complete conversion according to TLC, the resin was filtered off, and the crude was concentrated *in vacuo* to give product **90** as a yellow oil (277 mg, 1.55 mmol, 85%).

¹H NMR (400 MHz, CD₃OD) δ [ppm]: 3.80 (1H, s, H-sugar), 3.62 (1H, dd, *J* 9.4, 2.9, H-sugar), 3.56 (1H, dd, *J* 9.1, 6.2, H-sugar), 3.42-3.30 (5H, m, 2 x H-sugar, H-CH₃), 1.29 (3H, d, *J* 6.1, H-6). The NMR data is given in accordance with published data.¹⁴⁵

6.2.2 Methyl 2,3,4-Tri-*O*-benzyl-L-rhamnopyranoside **91**¹⁴⁶

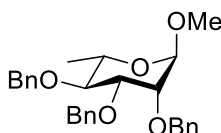

Methyl 2,3,4-tri-*O*-benzyl- α -L-rhamnopyranoside **91** was prepared according to a published procedure. Thus, compound **90** (1 eq, 260 mg, 1.46 mmol) was dissolved in dry DMF (5 ml) under N₂ atmosphere. NaH (4.5 eq, 261 mg, 60% dispersion in mineral oil, 6.53 mmol) was added to the stirred mixture at 0 °C. Benzyl bromide (4 eq, 0.7 ml, 5.8 mmol) was added slowly to the reaction mixture, then the mixture was allowed to warm up to rt. The reaction was monitored by TLC (Tol/ EtOAc 9:1, TLC samples were quenched in EtOAc and 2N HCl before applied to a TLC plate). After 1 h the reaction was quenched by careful addition of H₂O (5 ml) and then EtOAc (50 ml) was added. The organic layer was washed with brine (10 ml). After drying and concentration of the organic phase, the residue was purified by flash chromatography (Tol/EtOAc 50:1) giving a yellow syrup of **91** (396 mg, 0.83 mmol, 56%. R_f = 0.2 (Tol/ETOAc 50:1).

$[\alpha]_D^{23} = -28.7$ (c 4.0, CH_3Cl), reported: $[\alpha]_D^{20} = -27.8$ (c 1.5, CHCl_3).¹⁴⁷

^1H NMR (400 MHz, CD_3OD) δ [ppm]: 7.34-7.21 (15H, m, Ph-H), 4.95 (1H, d, J 10.9, Bn-H), 4.89 (1H, d, J 10.9, Bn-H), 4.76 (1H, d, J 12.5, Bn-H), 4.72 (1H, d, J 12.5, Bn-H), 4.65 (1H, s, H-1), 4.64 (1H, d, J 10.6, Bn-H), 4.61 (2H, s, Bn-H₂), 3.84 (1H, dd, J 8.8, 3.1, H-3), 3.78 (1H, dd, J 2.9, 1.8, H-2), 3.71-3.58 (2H, m, H-4 & H-5), 3.29 (1H, s, H₃-1'), 1.34 (3H, d, J 5.9, H₃-6).

^{13}C NMR (100 MHz, CDCl_3) δ [ppm]: 138.6, 138.6, 138.3 ($3 \times$ Ph-Cq), 128.5, 128.1, 128.0, 127.8, 127.7, 127.6 ($15 \times$ Ph-CH), 99.2 (CH, C-1), 80.6 (CH, C-4), 80.3 (CH, C-3), 75.5 (Bn-CH₂), 74.9 (CH, C-2), 72.9 (Bn-CH₂), 72.2 (Bn-CH₂), 68.0 (C-5), 54.7 (CH₃, C-1'), 18.1 (C-6). This data is given in accordance with the published data.¹⁴⁶

IR $\tilde{\nu}$ [cm^{-1}]: 3070, 3060, 3030, 2970, 2920, 2860, 1496, 1454, 1358, 1280, 1207, 1094, 1075, 1064, 915, 736, 697.

6.2.3 1,2,3,4-Tetra-*O*-acetyl-L-rhamnopyranose **93**

6.2.3.1 Alternative 1¹⁴⁸

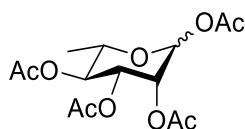

1,2,3,4-Tetra-*O*-acetyl-L-rhamnopyranose **93** was prepared according to a published procedure,¹⁴⁹ thus, monohydrate **89** (1 eq, 10.0 g, 60 mmol) was dissolved in pyridine (70 ml) followed by the addition of acetic anhydride (6 eq, 34 ml, 360 mmol) and DMAP (100 mg, \times mmol) under N_2 atmosphere. The mixture was stirred at rt for 3 hours and monitored by TLC (Tol/EtOAc 9:1). The solution was concentrated in vacuo and excess pyridine was removed by repeated (4 \times) co-evaporation with toluene. The residue was purified by flash chromatography (Tol/EtOAc 20:1 \rightarrow 9:1) to give a colourless oil (19.4 g, 58 mmol, 96% as a mixture of pseudo anomers 83:17). $R_f = 0.24$ (Tol / EtOAc 9:1).

$[\alpha]_D^{19} = -36.4$ (c 0.9, CH_3Cl), reported: $[\alpha]_D^{25} = -43.5$ (c 0.9, CHCl_3).

^1H NMR (400 MHz, CDCl_3) δ [ppm]: 5.96 (1 H, d, J 1.4, H-1), 5.25 (1 H, dd, J 10.1, 3.5, H-3), 5.20 (1 H, dd, J 3.4, 1.9, H-2), 5.05 (1 H, m, H-4), 3.89 (1 H, dq, J 12.4, 6.2, H-5), 2.12, 2.1, 2.01, 1.95 ($4 \times$ 3 H, s, $\text{CH}_3\text{-OAc}$), 1.18 (3 H, d, J 6.2, H-6).

^{13}C NMR(100 MHz, CDCl_3) δ [ppm]: 170.0, 169.8, 168.5, 168.4 (4 \times CO, OAc), 90.6 (CH, C-1), 71.5(CH, C-4), 70.7(CH, C-3), 70.5 (CH, C-2), 70.2 (CH, C-5), 21.0, 20.9, 20.7, 20.6 (4 \times CH_3 , OAc), 14.2 (C-6). This data is given for the major α -anomer and is in accordance with the published data.¹⁵⁰

IR $\tilde{\nu}$ [cm^{-1}]:2986, 1748, 1432, 1370, 1218, 1181, 1148, 1087, 1055, 1027, 974, 911, 889, 754, 601, 563.

6.2.3.2 Alternative 2

L-Rhamnose **93** was prepared according to a published procedure,¹⁵¹ thus, L-Rhamnose **89** (1 eq, 5.0 g, 30 mmol) was added in portions to a heated (130 $^\circ\text{C}$, oil bath temperature) mixture of NaOAc (2 eq, 5.0 g, 60 mmol) and acetic anhydride (6 eq, 17 ml, 180 mmol). The reaction was monitored by TLC (Tol/EtOAc 9:1). After 30 minutes, the reaction mixture was poured over finely crushed ice (30 ml). The mixture was extracted with EtOAc (2 \times 25 ml). The organic phase was washed with sat. NaHCO_3 solution (3 \times 25 ml) followed by brine (25 ml). After drying and concentration of the organic phase, the residue was purified by flash chromatography (Tol/EtOAc 20:1 \rightarrow 9:1) giving a colourless oil (6.0 g, 18 mmol, 60 %). $R_f = 0.24$ (Tol / EtOAc 9:1). The NMR data was as reported for alternative 1 and in accordance with published data.¹⁵²

6.2.4 3-(1'-Deoxy-2',3',4'-tri-O-acetyl-L-rhamnopyranose-1'-yl)-1-propene **94**¹⁵⁰

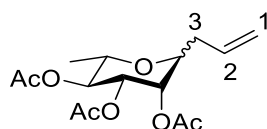

2,3,4-Tri-*O*-acetyl-1-allyl-L-rhamnopyranose **94** was prepared according to the in the compound title cited procedure, thus, $\text{BF}_3 \cdot \text{Et}_2\text{O}$ (14.3 ml, 114 mmol) and then TMSOTf (2.1 ml, 114 mmol) was added at 0 $^\circ\text{C}$ to a solution of rhamnoside **93** (1 eq, 19.0 g, 57 mmol) and allyltrimethylsilane (2 eq, 18.1 ml, 114 mmol) in dry CH_3CN (104 ml) under N_2 atmosphere. After addition of TMSOTf, the mixture changed immediately orange then deep brown after a couple of minutes. The reaction mixture was monitored by TLC (PE/ EtOAc 85:15), and the

reaction was completed after 3h. Et₂O (100 ml) was added to the reaction mixture prior quenching of the reaction with saturated NaHCO₃(aq) (50 ml). The organic phase was washed with H₂O (2 × 50 ml) then with brine (50 ml). The aqueous layer was extracted once with EtOAc (100 ml). The combined organic layers were washed once with brine (20 ml). After drying and concentration of the organic phase, the residue was purified by flash chromatography (PE/EtOAc 90:10 → 85:15) to give the title compound as a yellow oil **94** (14.3 g, 45 mmol, 79%, as a mixture of pseudo anomers α/β 90:10.). *R_f* = 0.25 (PE/EtOAc 85:15).

$[\alpha]_D^{19} = -5.9$ (*c* 0.7, CH₃Cl), reported: $[\alpha]_D^{25} = -7.4$ (*c* 1.0, CHCl₃).

¹H NMR(400 MHz, CDCl₃) δ [ppm]: 5.86-5.69 (1 H, ddt, *J* 17.1, 10.2, 6.9, H-2), 5.22 (2 H, m, H-3, H-2'), 5.17-4.96 (3 H, m, H-1, H-4'), 3.95 (1 H, ddd, *J* 8.8, 6.5, 2.3, H-1'), 3.77 (1 H, dq, *J* 12.6, 6.3, H-5'), 2.61-2.47 (1 H, m, H_A-3), 2.48-2.36 (1 H, m, H_B-3), 2.13 (3 H, s, CH₃-OAc), 2.06 (3 H, s, CH₃-OAc), 2.01 (3 H, s, CH₃-OAc), 1.23 (3 H, d, *J* 6.3, H-6').

δ ¹³C NMR(100 MHz, CDCl₃)[ppm]: 170.5, 170.3, 170.0 (3 × CO), 132.9 (C-2), 118.4 (C-1), 74.6 (C-1'), 71.7 (C-4'), 70.6 (C-3'), 69.2 (C-2'), 68.4 (C-5'), 33.8 (C-3), 21.1, 20.9, 20.8 (3 × CH₃-OAc), 17.8 (C-6'). The NMR data is given for the major α-anomer and is in accordance with published data.

IR $\tilde{\nu}$ [cm⁻¹]: 3080, 2981, 2940, 1741, 1642, 1435, 1370, 1244, 1220, 1115, 1049, 986, 928, 825, 761, 600, 544.

6.2.5 3-(1'-Deoxy-L-rhamnopyranose-1'-yl)-1-propene **95**¹⁵⁰

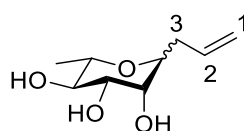

Compound **95** was prepared according to a published procedure. Thus, compound **94** (1 eq, 14.3 g, 45 mmol) was dissolved in methanol (90 ml). The mixture was then treated with NaOMe (0.24 g, pH ≈ 8-9) at rt and left stirring. The reaction mixture was monitored by TLC (DCM/MeOH 10:1) and the reaction was completed after 3 h. The mixture was neutralised by adding activated ion exchange resin (IR-120 Amberlite[®] resin) and gently stirred until pH ≈ 4 was reached. The resin was filtered off, and the crude was concentrated in vacuo to give product **95** as a yellow oil (8.3 g, 44 mmol, as a mixture of pseudo anomers 93/7, 98%, without purification). *R_f* = 0.25 (DCM/MeOH 10:1).

$[\alpha]_D^{19} = -35.1$ (*c* 0.8, CHCl₃), reported: $[\alpha]_D^{25} = -1.6$ (*c* 1.6, CHCl₃).

^1H NMR(400 MHz, CD_3OD) δ [ppm]: 5.76 (1 H, ddt, J 17.1, 10.2, 7.0, H-2), 5.20-5.03 (2 H, m, H-1), 3.80 (1 H, ddd, J 8.7, 6.4, 2.1, H-1'), 3.73-3.69 (1 H, m, H-2'), 3.58 (1 H, dd, J 8.8, 3.3, H-3'), 3.44 (1 H, dq, J 8.6, 6.1, H-5'), 3.34 (1 H, d, J 8.8, H-4'), 2.47-2.35 (1 H, m, H_A -3), 2.31-2.21 (1 H, m, H_B -3), 1.18 (1 H, d, J 6.1, H-6').

^{13}C NMR(100 MHz, CD_3OD) δ [ppm]: 135.9 (C-2), 117.4 (C-1), 78.6 (C-1'), 74.4 (C-5'), 72.5(C-3'), 72.3 (C-2'), 71.1 (C-4'), 34.8 (CH_2 , C-3), 18.3 (C-6'). The NMR data is given for the major α -anomer and is in accordance with published data.

IR $\tilde{\nu}$ [cm^{-1}]: 3376, 3079, 2976, 2933, 1642, 1445, 1417, 1382, 1256, 1139, 1099, 1059, 981, 870, 825, 779, 668.46, 551.

6.2.6 3-(1'-Deoxy-2',3',4'-tri-*O*-benzyl- α -L-rhamnopyranose-1'-yl)-1-propene **92**¹⁵³

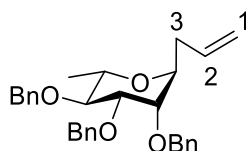

Procedure A: Compound **92** was prepared according to a published procedure. Thus, TMSOTf (0.6 eq, 100 μl , 0.5 mmol) was added at 0 $^\circ\text{C}$ to a solution of rhamnoside **91** (1 eq, 388 mg, 0.87 mmol) and allyltrimethylsilane (2.7 eq, 400 μl , 2.35 mmol) in dry CH_3CN (2 ml) under N_2 atmosphere. After addition of TMSOTf, the mixture changed immediately orange and then deep brown after a couple of minutes. The reaction mixture was monitored by TLC (PE/ EtOAc 90:10), and the reaction was completed after overnight. Et_2O (30 ml) was added to the reaction mixture prior quenching of the reaction with saturated $\text{NaHCO}_3(\text{aq})$ (5 ml). The organic phase was washed with H_2O (5 ml) then with brine (5 ml). After drying and concentration of the organic phase, the residue was purified by flash chromatography (PE/EtOAc 50:1 \rightarrow 25:1) to give the title compound **92** (210 mg, 0.45 mmol, 52%) as a colourless oil.

Procedure B: Compound **95** (1 eq, 8.0 g, 43 mmol) was dissolved in dry DMF (64 ml) under N_2 atmosphere. NaH (4.5 eq, 7.6 g, 60% dispersion in mineral oil, 190 mmol) was added to the stirred mixture at 0 $^\circ\text{C}$ in two portions to avoid foaming due to the emergence of H_2 gas. Benzyl bromide (4 eq, 20 ml, 170 mmol) was added slowly to the reaction mixture, then the mixture was allowed to warm up to rt. The reaction was monitored by TLC (Tol/ EtOAc 9:1, samples were quenched in EtOAc and 2N HCl before applied to a TLC plate). After 3 h the reaction

was quenched by careful addition of diethyl ether (500 ml) and subsequently dropwise addition of H₂O (100 ml). The organic layer was washed with brine (100 ml). After drying and concentration of the organic phase, the residue was purified by flash chromatography (PE/EtOAc 100:1 → 50:1 → 25:1 → 10:1) giving a yellow syrup (14.0 g, 30 mmol, 71% as a mixture of pseudo anomers α/β 91:9). $R_f = 0.62$ (Tol/ETOAc 9:1). A second column separation was performed to separate α and β anomers 9:1 (PE/ DE 90:10 → 85:15) giving a colourless syrup of the title compound **7** (12.6g, 27.6 mmol, 91%). $R_f = 0.16$ (PE/DE 85:15).

$[\alpha]_D^{24} = -8.8$ (c 4.15, CH₃Cl), reported: $[\alpha]_D^{25} = -7.7$ (c 1.50, CHCl₃).

¹H NMR(400 MHz, CDCl₃) δ [ppm]: 7.41-7.16 (15H, m, Ph-H), 5.64 (1H, ddt, J 17.1, 10.3, 6.9, H-2), 5.02-4.87 (2H, m, H₂-1), 4.79 (1H, d, J 11.1, Bn-H), 4.64-4.49 (5H, m, 5 \times Bn-H), 4.01 (1H, td, J 7.9, 3.5, H-1'), 3.74 (1H, dd, J 7.9, 3.1, H-3'), 3.67 (1H, dq, J 7.1, 6.5, H-5'), 3.62 (1H, t, J 3.3, H-2'), 3.58 (1H, t, J 7.7, H-4'), 2.35 (1H, dt, J 14.6, 7.4, H_B-3), 2.22 (1H, dt, J 14.1, 6.9, H_A-3), 1.32 (1H, d, J 6.2, H₃-6').

¹³C NMR (100 MHz, CDCl₃) δ [ppm]: 138.5, 138.3, 138.3 (3 \times Ph-Cq), 134.2 (C-1), 128.4-127.6 (Ph-CH), 117.2 (C-2), 80.2 (C-4'), 78.0 (C-2'), 75.2 (C-3'), 74.6 (Bn-CH₂), 73.0 (C-1'), 72.0, 71.7 (2 \times Bn-CH₂), 69.7 (C-5'), 34.3 (C-3), 18.1 (C-6').

IR $\tilde{\nu}$ [cm⁻¹]: 3064, 3030, 2975, 2932, 2871, 1951, 1812, 1641, 1496, 1454, 1358, 1280, 1207, 1094, 1075, 914, 736, 697.

HRMS (ESI) calculated for C₃₀H₃₅O₄ [M + H]⁺: 459.2529, found 459.2526.

6.2.7 2-(1'-Deoxy-2',3',4'-tri-*O*-benzyl- α -L-rhamnopyranose-1'-yl)ethanal

141

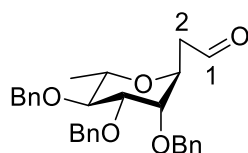

2,3,4-Tri-*O*-benzyl- α -L-rhamnopyranosylethanal **141** was prepared following a published procedure for an ozonolysis of α,β -unsaturated carbonyl compounds.¹⁵⁴ Thus, under dry conditions, alkene compound **92** (1 eq, 460 mg, 1 mmol) was dissolved in dry DCM (25 ml). Ozonised oxygen was bubbled at -78 °C through this solution. The end of the reaction was indicated (15 mins) by the persistence of a blue colour due to excess of ozone present and the flow of

ozonised oxygen stopped. Then, the reaction was continued to be stirred until the blue colour had disappeared before PPh₃ (1.5 eq, 393 mg, 1.5 mmol) was added. Stirring was continued until the mixture had reached 0 °C. TLC was applied in (PE/ EtOAc 9:1) The cooling bath was removed completely, and the crude compound was concentrated under reduced pressure. Purification by flash chromatography (PE/ DE 70:30 → 60:40) gave a colourless syrup of title compound **141** (443 mg, 1 mmol, 96%). This compound decomposes when stored at room temperature. Storage at -18 °C decelerates the process but does not prevent it. $R_f = 0.18$ (PE/EtOAc 9:1).

$$[\alpha]_D^{23} = -13.6 (c 5.2, \text{CH}_3\text{Cl}).$$

¹H NMR (400 MHz, CDCl₃) δ [ppm]: 9.70 (1H, t, J 2.0, H-1), 7.38-7.24 (15H, m, 15 × Ph-H), 4.60 (1H, d, J 11.8, Bn-H), 4.58-4.53 (5H, m, H-1', 4 × Bn-H), 4.51 (1H, d, J 11.9, Bn-H), 3.84 (1H, dq, J 6.6, 4.7, H-5'), 3.77 (1H, dd, J 5.5, 3.0, H-3'), 3.59 (1H, dd, J 6.6, 3.0, H-2'), 3.53 (1H, t, J 5.1, H-4'), 2.68-2.56 (2H, m, H₂-2), 1.37 (3H, d, J 6.8, H₃-6').

¹³C NMR (100 MHz, CDCl₃) δ [ppm]: 200.5 (CHO, C-1), 138.1, 138.0, 137.8 (3 × Ph-C_q), 128.5, 128.4, 128.3, 128.1, 127.9, 127.8, 127.8 (15 × Ph-CH), 78.5 (C-4'), 75.9 (C-2'), 75.3 (C-3'), 73.2 (Bn-CH₂), 72.4 (Bn-CH₂), 71.5 (Bn-CH₂), 71.0 (C-5'), 66.1 (C-1'), 45.1 (CH₂, C-2), 17.2 (C-6').

IR $\tilde{\nu}$ [cm⁻¹]: 3064, 3031, 2992, 2975, 2906, 2735, 1718, 1604, 1544, 1496, 1453, 1363, 1297, 1207, 1175, 1067, 741, 633.

HRMS (ESI) calculated for C₂₉H₃₂O₅Na [M + Na⁺]: 483.2147, found 483.2157.

6.2.8 6-((*tert*-Butyldiphenylsilyl)oxy)hexan-1-ol **81**¹⁰⁴

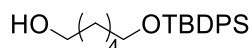

Compound **81** was prepared according to a published procedure, thus, co-solvent DIPEA (10 eq, 17.4 ml, 100 mmol) was added to a solution of hexane-1,6-diol **80** (1 eq, 1.2 g, 10 mmol) in anhydrous DMF (30 ml) forming a biphasic mixture at rt. Under N₂, TBDPSCl (1.1 eq, 2.5 ml, 11 mmol) was added drop-wise to the solution while stirring. The reaction progress was monitored by TLC (PE/EtOAc 70:30). After overnight stirring, the reaction was quenched with H₂O (40 ml) and extracted with EtOAc (2 × 100 ml). The extract was washed with 2N HCl

(150 ml) followed by sat. NaHCO₃ solution (100 ml). After drying and concentration of the organic phase, the residue was purified by flash chromatography (PE/EtOAc 90:10 → 85:15) giving a colourless oil **81** (1.8 g, 5 mmol, 50%). *R_f* = 0.35 (PE/ EA 70:30).

¹H NMR (400 MHz, CDCl₃) δ [ppm]: 7.67 (4H, dd, *J* 7.8, 1.5, Ph-H), 7.45-7.34 (6H, m, Ph-H), 3.64 (4H, dt, *J* 10.0, 6.3, H-6, H-1), 1.61-1.50 (4H, m, H-5, H-2), 1.44-1.29 (4H, m, H-4, H-3), 1.20 (1H, bd, *J* 4.5, H-OH), 1.05 (9H, s, *tert*-butyl).

¹³C NMR(100 MHz, CDCl₃) δ [ppm]: 135.6 (Ph-Cq), 134.1 (Ph-Cq), 129.5-127.6 (10 × Ph-CH), 63.8 (CH₂, C-6), 62.9 (CH₂, C-1), 32.8 (CH₂, C-2), 32.5 (CH₂, C-5), 26.9 (CH₃, *tert*-butyl), 25.6 (CH₂, C-4), 25.5 (CH₂, C-3), 19.2 (Cq, *tert*-butyl). The NMR data was in accordance with published data.

IR $\tilde{\nu}$ [cm⁻¹]: 3335, 3070, 3042, 2931, 2860, 1470, 1461, 1388, 1359, 1262, 1187, 1106, 1092, 1027, 1005, 994, 823, 736, 687, 613.

6.2.9 6-((*tert*-Butyldiphenylsilyl)oxy)1-iodo-hexane **82**¹⁰⁵

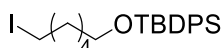

Iodide compound **82** was prepared according to a published procedure, thus, imidazole (1.5 eq, 0.5 g, 7.5 mmol) and I₂ (1.4 eq, 0.9 g, 7 mmol) were added to the stirred solution of PPh₃ (1.2 eq, 1.6 g, 6 mmol) in DCM (18 ml) at rt. This was followed by the slow addition of a solution of alcohol **81** (1 eq, 1.8 g, 5 mmol) in DCM (10 ml). The mixture was stirred for 2 days under N₂ atmosphere. The reaction mixture was monitored by TLC (PE/EtOAc 95:5). The mixture was then concentrated under reduced pressure and the residue purified by flash column chromatography (PE/DE 95:5 → 90:10) to give compound **82** as a colourless oil (2.4 g, 5 mmol, 93%). *R_f* = 0.7 (PE/EA 95:5).

¹H NMR (400 MHz, CDCl₃) δ [ppm]: 7.67 (4H, dd, *J* 7.8, 1.5, Ph-H), 7.46-7.28 (6H, m, Ph-H), 3.67 (2H, t, *J* 6.4, H-6), 3.17 (2H, t, *J* 7.1, H-1), 1.81 (2H, dd, *J* 8.9, 5.2, H-2), 1.61-1.52 (2H, m, H-5), 1.43-1.32 (4 H, m, H-3, H-4), 1.06 (9 H, s, *tert*-butyl).

¹³C NMR (100 MHz, CDCl₃) δ [ppm]: 135.7, 134.2 (2 × Ph-Cq), 133.9, 133.8, 129.7, 128.8, 128.7, 128.6, 127.7 (10 × Ph-CH), 63.8 (CH₂, C-6), 33.7 (CH₂, C-2), 32.4 (CH₂, C-5), 30.4 (CH₂, C-3), 27.0 (CH₃, *tert*-butyl), 24.9 (CH₂, C-4), 19.4 (Cq, *tert*-butyl), 7.2 (CH₂, C-1).

IR $\tilde{\nu}$ [cm^{-1}]: 3071, 3050, 2997, 2931, 2855, 1472, 1463, 1426, 1361, 1300, 1206, 1110, 1007, 938, 822, 736, 702, 614.

6.2.10 (6-((*tert*-Butyldiphenylsilyl)oxy)hexyl)triphenylphosphonium iodide **83**¹⁰⁶

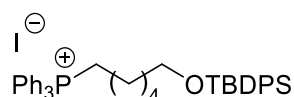

Wittig salt **83** was prepared according to a reported procedure for a similar Wittig salt. Thus, compound **82** (1 eq, 2.5 g, 5.4 mmol) and PPh_3 (1.2 eq, 1.7 g, 6.5 mmol) were dissolved in dry CH_3CN (20 ml) under N_2 atmosphere. The reaction was kept under reflux overnight. The reaction mixture was monitored by TLC (DCM/MeOH 10:1). The solvent was evaporated and the residue purified by flash chromatography (PE/EA 90:10 \rightarrow EA/MeOH 90:10) to give the product **83** as an oil. This oil was then dissolved in a minimum quantity of DCM forming a slurry, followed by addition of Et_2O (40 ml). After a few minutes stirring a white precipitate of **83** formed. The precipitate **83** was filtered and dried under high vacuum (2.5 g, 3.4 mmol 64%). $R_f = 0.6$ (PE/EA 95:5).

At a later stage, this reaction was repeated giving a yield of 80%.

^1H NMR (400 MHz, CDCl_3) δ [ppm]: 7.89-7.29 (25H, m, Ph-H), 3.75-3.66 (2H, m, H-6), 3.59 (2H, t, J 6.3, H-1), 1.69-1.59 (4H, m, H-5, H-2), 1.53-1.44 (2H, m, H-4), 1.34 (2H, dt, J 14.4, 7.0, H-3), 1.00 (9H, s, *tert*-butyl).

^{13}C NMR (100 MHz, CDCl_3) δ [ppm]: 135.5, 135.1, 135.0, (Ph-CH) 134.1 (Ph-Cq), 133.8, 133.7, 130.6, 130.5, 129.5, 127.6 (Ph-CH), 118.7, 117.9 (Ph-Cq), 63.7 (CH_2 , C-6), 32.0 (CH_2), 30.1 (d, J 15.6, CH_2 , C-1), 26.9 ($3 \times \text{CH}_3$, *tert*-butyl), 25.5 (CH_2), 22.8 (d, J 26.7 CH_2), 22.5 (CH_2), 19.2 (Cq, *tert*-butyl).

IR $\tilde{\nu}$ [cm^{-1}]: 3049, 3003, 2932, 2885, 2856, 2363, 1965, 1825, 1485, 1471, 1460, 1437, 1427, 1360, 1317, 1189, 1161, 1110, 1028, 995, 924, 825, 738, 728, 700, 685, 622, 614.

6.2.11 6-Bromohexan-1-ol **145**¹⁰⁷

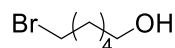

6-Bromohexan-1-ol **145** was prepared according to a reported procedure, thus, a solution of hexane-1,6-diol **80** (1 eq, 5.0 g, 42.3 mmol), 48% HBr (7.5 ml, 1.5 eq) and toluene (50 ml) was kept under reflux for overnight. The reaction mixture was monitored by TLC (PE/EtOAc 80:20). After cooling to rt, the mixture was diluted with Et₂O (100 ml), and washed with sat. NaHCO₃ (2 × 30 ml) and water (1 × 30 ml). After drying and concentration of the organic phase, the residue was purified by flash chromatography (PE/EA 90:10 → 80:20) to give the title compound as a colourless oil (4.0 g, 22 mmol, 52%). 1,6-dibromohexane was obtained as a side product in 24% yield. $R_f = 0.18$. (PE/EA 90:10).

¹H NMR (400 MHz, CDCl₃) δ [ppm]: 3.63 (2H, t, J 6.5, H-1), 3.40 (2H, t, J 6.8, H-6), 1.92-1.80 (2H, m, H-5), 1.62-1.32 (7H, m, H-2, H-3, H-4, OH-1).

¹³C NMR (100 MHz, CDCl₃) δ [ppm]: 62.7 (C-6), 33.8 (C-1), 32.7 (C-2), 32.4 (C-5), 27.9 (C-3), 24.9 (C-4).

IR $\tilde{\nu}$ [cm⁻¹]: 3322, 2932, 2858, 1459, 1430, 1372, 1298, 1258, 1132, 1051, 952, 891, 808, 727, 642, 560, 446.

6.2.12 6-((*tert*-Butyldiphenylsilyl)oxy)-1-bromohexane **146**¹⁰⁸

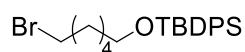

6-((*tert*-Butyldiphenylsilyl)oxy)-1-bromo-hexane **146** was prepared according to a published procedure. Thus, the monobromide **145** (1 eq, 7.3 g, 40 mmol) was dissolved in dry DCM (55 ml) and then imidazole (2 eq, 5.4 g, 80 mmol) and TBDPSCl (1.5 eq, 15.5 ml, 60 mmol) were added. The solution was stirred overnight at rt under N₂. The reaction mixture was monitored by TLC (PE/DE 99:1). After concentration of the reaction mixture, flash chromatography was used to purify the residue (PE/DE 99:1) giving silylether **146** as a yellow oil (15.0 g, 38 mmol, 95%). $R_f = 0.36$ (PE/ DE 99:1).

^1H NMR (400 MHz, CDCl_3) δ [ppm]: 7.72-7.64 (4H, "dd", 7.8, 1.5, Ph-H), 7.48-7.35 (6H, m, Ph-H), 3.68 (2H, t, J 6.4, H-1), 3.40 (2H, t, J 6.9, H-6), 1.89-1.78 (2H, m, H-5), 1.63-1.51 (2H, m, H-2), 1.48-1.34 (4H, m, H-3, H-4), 1.07 (9H, s, *tert*-butyl).

^{13}C NMR (100 MHz, CDCl_3) δ [ppm]: 135.6 (Ph-CH), 134.1 (Ph-Cq), 129.5, 127.6 ($2 \times$ Ph-CH), 63.7 (C-1), 33.9 (C-6), 32.8 (C-5), 32.3 (C-2), 27.9 (C-3), 26.9 ($3 \times$ CH_3 , *tert*-butyl), 24.9 (C-4), 19.2 (Cq, *tert*-butyl). The NMR data was in accordance with published data.

IR $\tilde{\nu}$ [cm^{-1}]: 3070, 3048, 2930, 2856, 1471, 1461, 1427, 1360, 1263, 1241, 1187, 1105, 1029, 1007, 997, 822, 792, 738, 699, 687, 612, 462, 542, 502, 486, 425.

6.2.13 (6((*tert*-Butyldiphenylsilyl)oxy)hexyl)triphenylphosphoniumbromide **147**¹⁰⁹

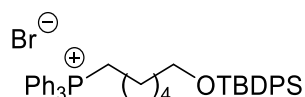

Compound **147** was prepared in a similar way as described for compound **83**. Thus, bromide **146** (1 eq, 2.0 g, 4.7 mmol) was dissolved in dry CH_3CN (25 ml) and PPh_3 (1.2 eq, 1.5 g, 5.6 mmol) was added. The reaction mixture was refluxed for overnight under N_2 atmosphere. The reaction mixture was monitored by TLC (EA/MeOH 90:10). After concentration of the reaction mixture, flash chromatography was used to purify the residue (PE/EtOAc 90:10 \rightarrow EA/MeOH 90:10). The reaction mixture was monitored by TLC (PE/DE 99:1). After concentration of the reaction mixture, flash chromatography was used to purify the residue (PE/EtOAc 90:10 \rightarrow EA/MeOH 90:10) giving a sticky white foam **147** (2.5 g, 3.7 mmol, 78%). $R_f = 0.23$ (EA/MeOH 90:10).

^1H (400 MHz, CDCl_3) δ [ppm]: 7.88-7.55 (19H, m, Ph-H), 7.40-7.28 (6H, m, Ph-H), 3.82-3.70 (2H, m, H-6), 3.57 (2H, t, J 6.3, H-1), 1.67-1.52 (4H, m, H-5, H-4), 1.51-1.40 (2H, m, H-2), 1.37-1.26 (2H, m, H-3), 0.99 (9H, s, *tert*-butyl).

^{13}C (100 MHz, CDCl_3) δ [ppm]: 135.5-135.0 (Ph-CH), 134.0 (Ph-Cq), 134.0-127.6 (Ph-CH), 118.8, 118.0 (Cq), 63.7 (C-1), 32.0 (C-2), 30.1-(d, J 15.6, C-5), 26.9 ($3 \times$ CH_3 , *tert*-butyl), 25.5 (C-3), 22.7 (d, J 49.7, C-6), 22.6 (d, J 4.5, C-4), 19.2 (Cq, *tert*-butyl).

IR $\tilde{\nu}$ [cm^{-1}]: 3047, 2929, 2853, 2791, 1587, 1483, 1470, 1437, 1390, 1360, 1186, 1156, 1107, 1029, 995, 923, 865, 794, 723, 702, 688, 612, 538, 529, 506, 491, 460, 435.

6.2.14 8-(2',3',4'-Tri-O-benzyl-1'-deoxy- α -L-rhamnopyranos-1'yl)-1-(*tert*-butyldiphenylsilyloxy)oct-6-ene **142**

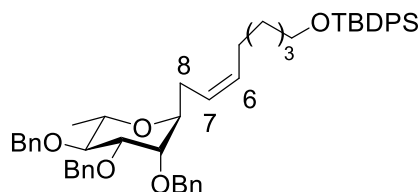

Wittig product **142** was prepared adapting a published procedure for a different compound,¹⁵⁵ To the Wittig salt **83** (2 eq, 42.3 g, 58 mmol) dry THF (200 ml) and dry DMPU (50 ml) was added. The slurry was then cooled to $-78\text{ }^{\circ}\text{C}$ under N_2 atmosphere. LiHMDS (2 eq, 58 ml, 58 mmol) was added drop-wise to the reaction mixture to keep the temperature below $-70\text{ }^{\circ}\text{C}$, while the mixture turned bright orange. Then a solution of aldehyde **141** (1 eq, 13.4 g, 29 mmol) in dry THF (50 ml) was added slowly to the stirred mixture while keeping the temperature below $-70\text{ }^{\circ}\text{C}$. The reaction mixture was monitored by TLC (DE/PE 50:50). The reaction mixture was allowed to slowly reach $0\text{ }^{\circ}\text{C}$ before quenched with 1M NH_4Cl (60 ml). After dilution with Et_2O (3×300 ml), washing with water (3×150 ml), the organic phase was dried and concentrated. The residue was purified by flash chromatography (PE /EA 90:10) to give colourless oil **142** (10.4 g, 13.28 mmol, 46%). $R_f = 0.6$ (DE/PE 50:50).

$[\alpha]_D^{29} = -8.8$ (c 1.0, CH_3Cl).

^1H NMR (400 MHz, CDCl_3) δ [ppm]: 7.66(4H, "dd", 7.7, 1.6, Ph-H), 7.44-7.24 (21H, m, Ph-H), 5.41 (1H, dt, 10.7, 7.3, H-6), 5.24 (1H, dt, 10.8, 7.1, H-7), 4.87 (1H, d, J 11.0, Bn- CH_2), 4.70-4.60 (3H, m, $3 \times$ Bn- CH_2), 4.57 (1H, d, J 12.0, Bn-H), 4.54 (1H, d, J 12.0, Bn- CH_2), 3.96 (1H, td, J 7.4, 2.7, H-1'), 3.74 (1H, dd, J 8.0, 3.1, H-3'), 3.69-3.56 (5H, m, H-2', H-4', H-5', H-1), 2.35-2.19 (2H, m, H-8), 1.99-1.84 (2H, m, H-5), 1.61-1.49 (2H, m, H-2), 1.40-1.25 (4H, m, H-4, H-3), 1.35 (3H, d, J 5.9, H-6'), 1.04 (9H, s, *tert*-butyl).

^{13}C NMR (100 MHz, CDCl_3) δ [ppm]: 138.5, 138.4, 138.3 ($3 \times$ Ph-Cq), 135.6 (Ph-CH), 134.1 (Ph-Cq), 132.2 (C-6), 129.5-127.6 (Ph-CH), 124.7 (C-7), 80.4 (C-4'), 78.8 (C-3'), 75.0 (C-2'), 74.9 (Bn- CH_2), 74.2 (C-1'), 71.9, 71.7 ($2 \times$ Bn- CH_2), 69.6 (C-5'), 63.9 (C-1), 32.5 (C-2), 29.3 (C-4), 27.7 (C-8), 27.5 (C-5), 26.9 ($3 \times$ CH_3 , *tert*-butyl), 25.5 (C-3), 19.2 (Cq, *tert*-butyl), 18.3 (C-6').

IR $\tilde{\nu}$ [cm^{-1}]: 3088, 3067, 3029, 2931, 2858, 1605, 1588, 1496, 1472, 1454, 1428, 1360, 1216, 1111, 1028, 911, 756, 700, 666, 613.

HRMS (ESI) calculated for $\text{C}_{51}\text{H}_{66}\text{NO}_5\text{Si}$ [$\text{M} + \text{NH}_4$] $^+$: 800.4704, found. 800.4709.

6.2.15 8-(2',3',4'-Tri-O-benzyl-1'-deoxy- α -L-rhamnopyranos-1'yl)-oct-6-en-1-ol **126**

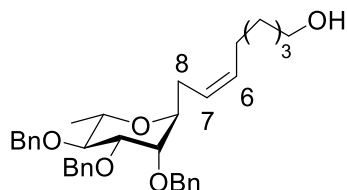

Deprotection of compound **126** was carried out by adapting a published procedure for the removal of a TBDPS group.¹⁵⁶ Thus, to a solution of Wittig product **142** (1 eq, 500 mg, 0.64 mmol) in THF (5 ml) TBAF (2 eq, 400 mg, 1.27 mmol) was added. The reaction mixture was monitored by TLC (PE/EtOAc 80:20) and then stirred at rt for 1 h under N₂ atmosphere. The resulting solution was concentrated under vacuum and purified by flash chromatography (PE/EA 80:20 → 70:30) to give colourless oil **126** (323 mg, 0.59 mmol, 93%). $R_f = 0.1$ (PE/EA 80:20)

$$[\alpha]_D^{22} = -8.0 \text{ (} c \text{ 2.8, CH}_3\text{Cl)}.$$

¹H NMR (400 MHz, CDCl₃) δ [ppm]: 7.40-7.22 (15H, m, H-Ph), 5.48-.5.38 (1H, m, H-6), 5.32-5.21 (1H, m, H-7), 4.85 (1H, d, J 11.0, Bn-H), 4.68 (1H, d, J 12.4 Bn-H), 4.65-4.60 (3H, m, Bn-H), 4.58 (1H, d, J 12.2, Bn-H), 4.54 (1H, d, J 12.3, Bn-H), 3.97 (1H, td, J 7.4, 3.0, H-1'), 3.75 (1H, dd, J 8.0, 3.1, H-3'), 3.69-3.62 (2H, m, H-2', H-5'), 3.62-3.56 (3H, m, H-4', H-1), 2.35-2.20 (2H, m, H-8), 2.01-1.89 (2H, m, H-5), 1.57-1.47 (2H, m, H-2), 1.39-1.29 (4H, m, H-4, H-3). 1.33 (3H, d, J 6.1, H-6').

¹³C NMR (100 MHz, CDCl₃) δ [ppm]: 138.4, 138.35, 138.3 (3 \times Ph-Cq), 132.0 (C-6), 128.4-127.6 (15 \times Ph-CH), 124.9 (C-7), 80.3 (C-4'), 78.7 (C-3'), 75.1 (C-2'), 74.9 (Bn-CH₂), 74.0 (C-1'), 71.9, 71.7 (2 \times Bn-CH₂), 69.7 (C-5'), 62.9 (C-1), 32.6 (C-2), 29.3 (C-4), 27.8 (C-8), 27.4 (C-5), 25.4 (C-3), 18.2 (C-6').

IR $\tilde{\nu}$ [cm⁻¹]: 3445, 3088, 3063, 3030, 3007, 2931, 2860, 1645, 1604, 1585, 1496, 1454, 1358, 1280, 1207, 1092, 1072, 1026, 909, 822, 777, 696.

HRMS (ESI) calculated for C₃₅H₄₅O₄ [M + H]⁺: 545.3261, found 545.3259.

6.2.16 8-(2',3',4'-Tri-O-benzyl-1'-deoxy- α -L-rhamnopyranos-1'-yl)-oct-6-en-1-yl tosylate **128**

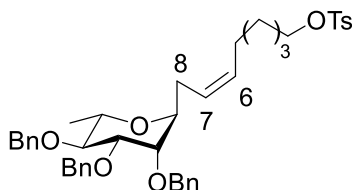

Tosylation of compound **126** was prepared by adapting a published procedure.¹⁵⁷ Thus, to a solution of alcohol **126** (1 eq, 480 mg, 0.9 mmol) in pyridine (8 ml), tosyl chloride (10 eq, 1.68 g, 9 mmol) was added at 0 °C. The reaction mixture was monitored by TLC (PE/EtOAc 70:30) and then stirred at rt for 1 h under N₂ atmosphere. The reaction mixture was co-evaporated with toluene (3×). The crude was purified by silica gel column chromatography (PE/EtOAc 100:0 → 90:10 → 80:20) to give a colourless syrup of the title tosylate **128** (630 mg, 0.8 mmol, 90%). R_f = 0.38 (PE/EtOAc 70:30).

$[\alpha]_D^{19} = -8.4$ (*c* 1.65, CH₃Cl).

¹H NMR (400 MHz, CDCl₃) δ [ppm]: 7.77 (2H, d, *J* 8.2, Ph-H), 7.38-7.24 (17H, m, Ph-H), 5.42-5.32 (1H, m, H-6), 5.29-5.22 (1H, m, H-7), 4.85 (1H, d, *J* 11.0, Bn-H), 4.67 (1H, d, *J* 12.4 Hz, Bn-H), 4.65-4.60 (3H, m, Bn-H), 4.58 (1H, d, *J* 12.6, Bn-H), 4.55 (1H, d, *J* 12.2, Bn-H), 3.99 (2H, t, *J* 6.5, H-1), 3.94 (1H, dt, *J* 7.3, 2.9, H-1'), 3.74 (1H, dd, *J* 7.9, 2.9, H-3'), 3.69-3.55 (3H, m, H-2', H-4', H-5'), 2.43 (3H, s, OTs-CH₃), 2.32-2.17 (2H, m, H-8), 1.95-1.82 (2H, m, H-5), 1.66-1.56 (2H, m, H-2), 1.32 (3H, d, *J* 6.0, H-6'), 1.36-1.20 (4H, m, H-4, H-3).

¹³C NMR (100 MHz, CDCl₃) δ [ppm]: 144.6, 138.4, 138.3, 138.2, 133.2, (5 × Ph-Cq), 131.6 (C-6), 129.8-127.6 (19 × Ph-CH), 125.2 (C-7), 80.3 (C-4'), 78.6 (C-3'), 75.2 (C-2'), 74.8 (Bn-CH₂), 73.9 (C-1'), 71.9, 71.7 (2 × Bn-CH₂), 70.5 (C-1), 69.7 (C-5'), 29.0 (C-4), 28.7 (C-2), 27.7 (C-8), 27.2 (C-5), 25.0 (C-3), 21.6 (Ts-CH₃), 18.2 (C-6').

IR $\tilde{\nu}$ [cm⁻¹]: 3062, 3029, 2970, 2928, 2860, 1598, 1495, 1453, 1356, 1306, 1291, 1208, 1188, 1174, 1094, 1074, 948, 814, 735, 697, 663, 554.

6.2.17 8-(1'-Deoxy- α -L-rhamnopyranos-1'yl)oct-1-yl tosylate **129**

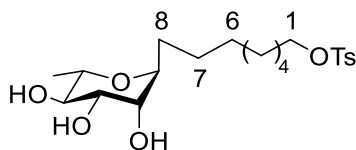

Hydrogenation of compound **128** was carried out by adapting a published procedure for deprotection of benzyl ether in the presence of a tosyl group.¹⁵⁸ Thus, Pd(OH)₂/C (100 mg) suspended in MeOH (25 ml) was added to a stirring mixture of compound **128** (1 eq, 550 mg, 0.78 mmol) in EtOAc (25 ml). The reaction mixture was monitored by TLC (DCM/MeOH 10:1) and then stirred at rt for overnight under H₂ atmosphere. The resulting mixture was filtered over Celite[®], then the filter pad was washed several times with MeOH (total volume 15 ml). The solution was concentrated under reduced pressure to give the deprotected tosylate **129** as a colourless oil (340 mg, 0.76 mmol, 97%). R_f = 0.4 (DCM/MeOH 10:1).

$[\alpha]_D^{19} = -10$ (*c* 1.7, CH₃OH).

¹H NMR (400 MHz, CD₃OD) δ [ppm]: 7.78 (2H, d, *J* 8.1, Ar-H), 7.45 (2H, d, *J* 8.1, Ar-H), 4.02 (2H, t, *J* 6.3, H-1), 3.76 (1H, br d, *J* 8.3, H-1'), 3.74-3.70 (1H, m, H-2'), 3.60 (1H, dd, *J* 8.7, 3.2, H-3'), 3.48-3.40 (1H, m, H-5'), 3.40-3.34 (1H, m, H-4'), 2.46 (3H, s, Ts-CH₃), 1.79-1.66 (1H, m, H_A-8), 1.66-1.55 (2H, m, H-2), 1.48-1.18 (11H, m, H-3-H_B-8), 1.24 (3H, d, *J* 5.9, H-6').

¹³C NMR (100 MHz, CD₃OD) δ [ppm]: 146.4, 134.7 (2 × Ar-Cq), 131.0, 129.0 (2 × Ar-CH), 79.1 (C-1'), 74.5 (C-4'), 73.3 (C-2'), 72.8 (C-3'), 72.1 (C-1), 70.8 (C-5'), 30.4, 30.3, 29.9, 29.8, 29.6, 27.1, 26.4 (7 × CH₂, C-2-C-8), 21.6 (Ts-CH₃), 18.5 (C-6').

IR $\tilde{\nu}$ [cm⁻¹]: 3374, 3080, 2928, 2856, 1495, 1435, 1355, 1214, 1188, 1174, 1122, 1095, 1061, 937, 814, 750.662.

6.2.18 8-(1'-Deoxy- α -L-rhamnopyranos-1'yl)-oct-1-azide **130**

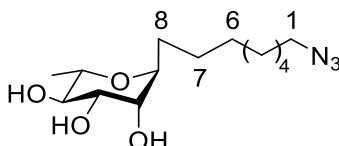

Azido compound **130** was prepared by adapting a published procedure for the substitution of a tosylate for an azide.¹⁵⁹ Thus, to a solution of compound **129** (1 eq, 3.5 g, 8 mmol) in dry DMF (30 ml), NaN₃ (3 eq, 1.6 g, 24 mmol) was added. The reaction mixture was heated at 130 °C

and monitored by TLC (DCM/MeOH 10:1) for 1.5 h. After the reaction mixture had been allowed to cool down to rt, it was taken between H₂O (100 ml) and EtOAc (300 ml). The organic phase was then washed with water (2 × 150 ml), dried and concentrated in vacuum. The residue was purified by flash chromatography (DCM/MeOH 30:1) to give the azide **130** as a colourless oil (1.7 g, 5.74 mmol, 71%). $R_f = 0.2$ (DCM/MeOH 10:1)

$$[\alpha]_D^{22} = -7 \text{ (} c \text{ 0.9, CH}_3\text{OH)}.$$

¹H NMR (400 MHz, CD₃OD) δ [ppm]: 3.78 (1H, br d, J 8.7, H-1'), 3.74-3.70 (1H, m, H-2'), 3.61 (1H, dd, J 8.7, 3.3, H-3'), 3.48-3.40 (1H, m, H-5'), 3.37 (1H, "t", J 8.8, H-4'), 3.27 (2H, t, J 6.8, H-1), 1.82-1.68 (1H, m, H_A-8), 1.64-1.53 (2H, m, H-2), 1.49-1.27 (11H, m, H-3-H_B-8), 1.24 (3H, d, J 5.9, H-6').

¹³C NMR (100 MHz, CD₃OD) δ [ppm]: 79.1 (C-1'), 74.4 (C-4'), 73.3 (C-2'), 72.7 (C-3'), 70.7 (C-5'), 52.4 (C-1), 30.5, 30.3, 30.2 (3 × CH₂, C-4, C-5, C-6), 29.9 (C-2), 29.6 (C-8), 27.8 (C-3), 27.1 (C-7), 18.4 (C-6').

IR $\tilde{\nu}$ [cm⁻¹]: 3363, 2931, 2856, 2094, 1646, 1455, 1463, 1379, 1347, 1259, 1062, 972, 902, 877, 825, 723, 653.

HRMS (ESI) calculated for C₁₄H₂₈N₃O₄ [M + H]⁺: 302.2074, found 302.2074.

6.2.19 1,2,3,4,6-Penta-O-acetyl- α,β -D-mannopyranose **27**

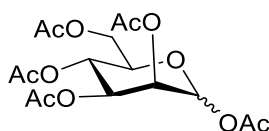

Peracetylated D-mannose **27** was prepared by adapting a published procedure.¹⁶⁰ Thus, D-mannose **63** (1 eq, 18.0 g, 100 mmol) was dissolved in pyridine (130 ml) followed by the addition of acetic anhydride (10 eq, 94 ml, 1 mol) and DMAP (200 mg). The mixture was stirred at rt under N₂ atmosphere and completed after 2 h according to TLC (PE/EtOAc 70:30). The solution was concentrated under reduced pressure. The residue was dissolved in EtOAc (100 ml) and washed with a solution of sat. of CuSO_{4(aq)} (3×100 ml) in order to remove excess pyridine. A saturated aqueous solution of NaHCO₃ was added to the organic phase until pH 7 was attained (ca 50 ml), followed by washing with brine (30 ml). After drying, the organic phase was concentrated under reduced pressure, giving sufficiently pure **27** as a colourless foam (38.0 g, 97 mmol, 97% as a mixture of pseudo anomers α/β 87:13). $R_f = 0.18$ (PE/EtOAc 70:30).

$[\alpha]_D^{21} = +53.8$ (c 1.0, CH_3Cl), reported: $[\alpha]_D^{20} = +53$ (c 1.0, CHCl_3).¹⁶¹

^1H (400 MHz, CDCl_3) δ [ppm]: 6.09 (1H, d, J 1.7, H-1), 5.37-5.33 (2H, m, H-3, H-4), 5.26 (1H, t, J 2.0, H-2), 4.29 (1H, dd, J 12.3, 4.8, H_A -6), 4.10 (1H, dd, J 12.4, 2.4, H_B -6), 4.10 - 4.02 (1H, m, H-5), 2.18, 2.17, 2.10, 2.06, 2.01 (15H, 5s, $5 \times \text{OAc-CH}_3$).

^{13}C (100 MHz, CDCl_3) δ [ppm]: 170.5, 169.9, 169.7, 169.5, 168.0 ($5 \times \text{CO-OAc}$), 90.6 (CH, C-1), 70.6 (C-5), 68.7 (C-3), 68.3 (C-2), 65.5 (C-4), 62.1 (C-6), 20.8, 20.7, 20.7, 20.6, 20.6 ($5 \times \text{CH}_3\text{-OAc}$). The NMR data is given for the major α -anomer and is in accordance with published data.

IR $\tilde{\nu}$ [cm^{-1}]: 2964, 1748, 1653, 1435, 1370, 1217, 1149, 1087, 1053, 1027, 974, 755, 668, 600, 555.

6.2.20 3-(1'-Deoxy-2',3',4',6'-Tetra-O-acetyl-D-mannopyranose-1'-yl)-1-propene **96**¹⁶²

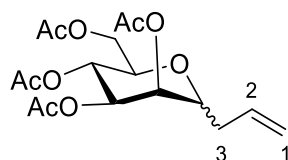

Allylation of compound **27** was prepared by adapting a published procedure. Thus, $\text{BF}_3 \cdot \text{Et}_2\text{O}$ (38 ml, 300 mmol) and TMSOTf (2.2 ml, 12 mmol) were added at 0 °C to a solution of mannoside **27** (1 eq, 23.0 g, 60 mmol) and allyltrimethylsilane (4 eq, 38 ml, 240 mmol) in dry CH_3CN (250 ml) under N_2 atmosphere. After addition of TMSOTf, the mixture changed to an orange colour. The reaction was left stirring overnight at rt (TLC: PE/EtOAc 1:1). Then, diethyl ether (1 L) was added to the reaction mixture and saturated $\text{NaHCO}_3(\text{aq})$ (250 ml) was added to quench the reaction. The resulting mixture was washed with H_2O (2×250 ml), brine (250 ml), dried, and concentrated under reduced pressure. The crude was purified by flash chromatography (PE/ EtOAc 80:20 \rightarrow 70:30) giving the product **96** as a yellow oil (15.0 g, 40 mmol, 67 % as a mixture of pseudo anomers α/β 83:17). $R_f = 0.1$ (PE/EtOAc 80:20).

$[\alpha]_D^{22} = +1.3$ (c 0.7, CH_3Cl), reported: $[\alpha]_D^{25} = +1.6$ (c 1.2, CHCl_3).¹⁶³

^1H (400 MHz, CDCl_3) δ [ppm]: 5.76 (1H, ddt, J 17.1, 10.3, 6.9, H-2), 5.25 (1H, dd, J 8.9, 3.2, H-3'), 5.22-5.06 (4H, m, H-1, H-2', H-4'), 4.31 (1H, dd, J 12.1, 6.3, H_A -6'), 4.09 (1H, dd, J 12.1, 2.9, H_B -6'), , 4.03 (1H, ddd, J 9.0, 6.0, 3.2, H-1'), 3.92-3.84 (1H, m, H-5'), 2.51 (1H, "dt", J 15.8, 8.0, H_B -3), 2.45-2.34 (1H m, H_A -3), 2.11, 2.07, 2.05, 2.01 ($4 \times 3\text{H}$, 4s, $\text{CH}_3\text{-OAc}$).

^{13}C NMR (100 MHz, CDCl_3) δ [ppm]: 170.8, 170.3, 170.1, 169.8 ($4 \times \text{CO-OAc}$), 132.6 (C-2), 118.4 (C-1), 74.3 (C-1'), 70.7 (C-5'), 70.1 (C-2'), 68.9 (C-3'), 67.1 (C-4'), 62.5 (C-6'), 33.7 (CH_2 , C-3), 21.1, 20.9, 20.8 ($4 \times \text{CH}_3\text{-OAc}$). The NMR data is given for the major α -anomer and is in accordance with published data.

IR $\tilde{\nu}$ [cm^{-1}]: 3085, 2958, 1744, 1644, 1557, 1506, 1435, 1370, 1226, 1115, 1049, 917, 764, 668, 602, 548.

6.2.21 3-(1'-Deoxy-D-mannopyranos-1'-yl)-1-propene **97**¹⁶⁴

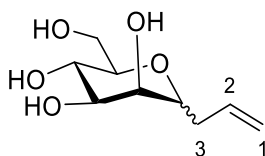

Deacetylation of compound **97** was prepared by adapting a published procedure. Thus, compound **96** (1 eq, 14.0 g, 37.5 mmol) was dissolved in methanol (130 ml). Then a solution of NaOMe (66ml, 3.7mmol, $\text{pH} \approx 8$ or 9) was added at rt and the reaction mixture left stirring. The reaction was monitored by TLC (DCM/MeOH 9:1) for 1 h. The mixture was then neutralised by adding Amberlite[®] resin and gently stirred until pH paper indicated a $\text{pH} \approx 4$. The resin was filtered off, and the crude was concentrated in vacuum to give the product **97** as a yellow oil (7.0 g, 34 mmol, 91%, as a mixture of pseudo anomers 86:14). $R_f = 0.12$ (DCM/MeOH 9:1).

$[\alpha]_D^{22} = +38.7$ (c 0.9, CH_3OH), reported: $[\alpha]_D^{25} = +38.2$ (c 1.0, CH_3OH).⁶⁶

^1H NMR (400 MHz, CD_3OD) δ [ppm]: 5.86 (1H, ddt, J 17.1, 10.2, 6.9 H-2), 5.09 (2H, ddd, J 18.7, 13.1, 5.0, H-1), 3.94-3.88 (1H, m, H-1'), 3.80-3.74 (2H, m, $\text{H}_B\text{-6'}$, H-2'), 3.74-3.61 (3H, m, $\text{H}_A\text{-6'}$, H-3', H-4'), 3.49-3.43 (1H, m, H-5'), 2.49 (1H, ddd, J 14.8, 8.1, 7.0, $\text{H}_B\text{-3}$), 2.39-2.30 (2H, m, $\text{H}_A\text{-3}$).

^{13}C NMR (100 MHz, CD_3OD) δ [ppm]: 135.8 (C-2), 117.5 (C-1), 78.5 (C-1'), 76.0 (C-5'), 72.6 (C-3'), 72.1 (C-2'), 69.2 (C-4'), 62.9 (C-6'), 34.8 (C-3). The NMR data is given for the major α -anomer and is in accordance with published data.¹⁶²

IR $\tilde{\nu}$ [cm^{-1}]: 3358, 3079, 2970, 2925, 1764, 1643, 1558, 1506, 1436, 1369, 1226, 1066, 976, 916, 839, 780, 668, 554.

6.2.22 3-(1'-Deoxy-2',3',4',6'-tetra-O-benzyl- α -D-mannopyranos-1'-yl)-1-propene **11**⁷⁸

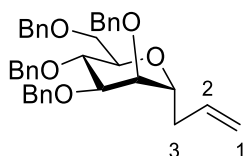

Benzylation of compound **97** was prepared by adapting a published procedure. Thus, compound **97** (1 eq, 5.0 g, 24 mmol) was dissolved in dry DMF (40 ml) under N₂ atmosphere. NaH (8 eq, 7.8 g as 60% dispersion in mineral oil, 192 mmol) was added to the stirred mixture at 0 °C in portions to avoid excessive foaming due to the emergence of H₂ gas. Benzyl bromide (6 eq, 17.5 ml, 144 mmol) was added dropwise to the reaction mixture. The mixture was allowed to attain rt after completed addition. The reaction was monitored by TLC (PE/ EtOAc 90:10, TLC samples were quenched in EtOAc and 2N HCl before applied to TLC plate which in turn was dried under vacuum before placed into the TLC chamber). After 2 h the reaction was quenched carefully by the dropwise addition of H₂O (100 ml) and subsequently EtOAc (250 ml). The organic layer was washed with brine (100 ml). The organic layer was then concentrated under vacuum and purified by flash chromatography (PE/EtOAc 90:10 → 80:20) giving a yellow syrup of **11** (11.0 g, 19.5 mmol, 81% as a mixture of pseudo anomers 89:11). In this step it was possible to fully separate the anomers in yield 90% by using (Tol/DE 99:1 → 95:5). R_f = 0.11 (PE/EtOAc 9:1).

$[\alpha]_D^{22} = +15.3$ (*c* 0.8, CHCl₃), reported: $[\alpha]_D^{25} = +16.7$ (*c* 2.7, CHCl₃).¹⁶⁵

¹H NMR (400 MHz, CDCl₃) δ [ppm]: 7.37-7.17 (20H, m, Ph-H), 5.75 (¹H, "ddt", *J* 18.8, 9.4, 6.9, H-2), 5.04 (1H, "s", H_B-1), 5.00 (1H, "d", *J* 3.8, H_A-1), 4.70 (1H, d, *J* 11.3, Bn-H), 4.62-4.49 (7H, m, Bn-H), 4.04 (1H, "dd", *J* 11.8, 6.9, H-1'), 3.89-3.80 (2H, m, H-4', H-5'), 3.80-3.74 (2H, m, H-3', H_B-6'), 3.71 (1H, dd, *J* 10.2, 3.4, H_A-6'), 3.62 (1H, dd, *J* 4.6, 3.1, H-2'), 2.41-2.26 (2H, m, H-3).

¹³C NMR (100 MHz, CDCl₃) δ [ppm]: 138.4, 138.3, 138.2 (4 × Ph-Cq), 134.3 (CH₂, C-2), 128.4-127.5 (20 × Ph-CH), 117.2 (CH₂, C-1), 76.9 (C-3'), 75.2 (C-2'), 74.9 (C-4'), 73.8 (Bn-CH₂), 73.7 (CH, C-5'), 73.3 (Bn-CH₂), 72.3 (CH, C-1'), 72.1 (Bn-CH₂), 71.5 (Bn-CH₂), 69.2 (CH₂, C-6'), 34.7 (CH₂, C-3).

IR $\tilde{\nu}$ [cm⁻¹]: 3063, 3029, 2863, 1640, 1604, 1495, 1453, 1362, 1309, 1278, 1089, 1072, 1026, 911, 844, 777, 695, 605, 546.

HRMS (ESI) calculated for C₃₇H₄₀O₅Na [M + Na]⁺: 587.2768, found 587.2764.

6.2.23 2',3',4',6'-Tetra-O-benzyl-2'- α -D-mannopyranosylethanal **137**¹⁶⁶

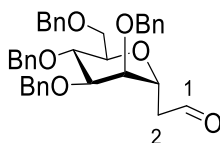

The aldehyde **137** was prepared by adapting a published procedure.¹⁵⁴ Thus, under dry conditions, alkene compound **11** (1 eq, 5.6 g, 10 mmol) was dissolved in dry DCM (100 ml). Ozonized oxygen was bubbled at -78 °C through this mixture. The end of the reaction was indicated (30 mins) by the persistence of a blue colour, which is due to excess of ozone in the solution. The reaction was continued to be stirred until the blue colour had disappeared. Then PPh₃ (1.5 eq, 3.40 g, 13 mmol) was added to the stirred mixture. TLC (PE/EtOAc 80:20) analysis showed complete conversion of starting material to a major product. Stirring was continued until the mixture had reached 0 °C. Then the cooling bath was removed and the crude compound was concentrated under reduced pressure. The compound was purified by flash chromatography (PE/ EtOAc 80:20 → 75:25) to give a colourless syrup **137** (5.0 g, 8.7 mmol, 87%). $R_f = 0.16$ (PE/EtOAc 80:20).

$[\alpha]_D^{22} = +25.2$ (c 4.0, CH₃Cl, no optical rotation has been reported for **137**).

¹H NMR (400 MHz, CDCl₃) δ [ppm]: 9.71 (1H, t, J 2.2, H-1), 7.38-7.16 (20H, m, Ph-H), 4.57-4.40 (8H, m, Bn-H), 4.51-4.43 (1H, m, H-1'), 3.98 (1H, br, H-5'), 3.83 (1H, dd, J 10.1, 6.7, H_B-6'), 3.80-3.76 (2H, m, H-3', H-4'), 3.71 (1H, dd, J 10.1, 5.5, H_A-6'), 3.60 (1H, dd, J 7.8, 2.0, H-2'), 2.68 (1H, ddd, J 16.3, 5.0, 2.0, H_B-2), 2.59 (ddd, J 16.3, 8.0, 2.5, H_A-2).

¹³C NMR (100 MHz, CDCl₃) δ [ppm]: 200.6 (C-1), 138.2, 137.9, 137.9, 137.7 (4 \times Ph-Cq), 128.5-127.6 (20 \times Ph-CH), 75.7 (CH, C-2'), 74.5 (CH, C-5'), 74.2, 74.0 (2 \times CH₂, C-3', C-4'), 73.3, 72.5, 72.4, 71.3 (4 \times Bn-CH₂), 68.2 (CH₂, C-6'), 66.2 (CH, C-1'), 45.6 (CH₂, C-2).

The NMR data was in accordance with published data.

IR $\tilde{\nu}$ [cm⁻¹]: 3087, 3063, 3030, 2903, 2866, 2731, 1725, 1604, 1586, 1496, 1454, 1397, 1366, 1253, 1207, 1094, 1028, 912, 819, 738, 698, 607.

Storage: No further analytical data. This compound is not very stable and should be stored at -18 °C.

6.2.24 8-(2',3',4',6'-Tetra-O-benzyl-1'-deoxy- α -D-mannopyranos-1'yl)-oct-6-en-1-(*tert*-butyldiphenylsilyl)oxy **138**

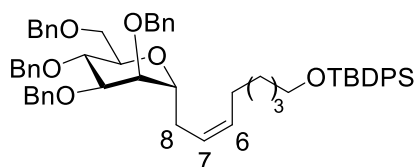

The Wittig coupling was prepared by adapting a published procedure for a different compound.¹⁵⁵ Thus, Wittig salt **83** (2 eq, 12.6 g, 17.4 mmol) in dry THF (70 ml) and dry DMPU (35 ml) was cooled to -78 °C under N_2 atmosphere. LiHMDS (2 eq, 17 ml, 17.4 mmol) was added to the solution drop-wise to keep the temperature below -70 °C, which turned bright orange shortly after addition of the LiHMDS had been completed. Then a solution of aldehyde **137** (1 eq, 5.0 g, 8.7 mmol) in dry THF (35 ml) was added dropwise to the stirred orange mixture containing the ylide while keeping the temperature below -70 °C. The reaction mixture was monitored by TLC (PE/EtOAc 90:10). The mixture was allowed to slowly reach to 0 °C, quenched with 1M NH_4Cl (85 ml), diluted with EtOAc (3×90 ml), washed with water (3×40 ml), and the resulting solution was concentrated under vacuum and purified by flash chromatography (PE/EtOAc 100:0 \rightarrow 95:5 \rightarrow 90:10) to give the Wittig product **138** as a colourless oil (6.2 g, 6.9 mmol, 80%). $R_f = 0.2$ (PE/EtOAc 90:10).

$[a]_D^{29} = +5.1$ (c 6.0, CH_3Cl).

1H NMR (400 MHz, $CDCl_3$) δ [ppm]: 7.66 (4H, dd, J 7.4, 1.3 Ph-H), 7.43-7.16 (26H, m, Ph-H), 5.47-5.37 (1H, m, H-6), 5.35-5.25 (1H, m, H-7), 4.74 (1H, d, J 11.1, Bn- CH_2), 4.65-4.47 (7H, m, Bn- CH_2), 4.02 (1H, td, J 7.1, 4.1, H-1'), 3.89 (1H, t, J 7.2 H-4'), 3.91-3.54 (4H, m, H-3, H-5, H_A -6, H_B -6), 3.66-3.62 (1H, m, H-2'), 3.63 (2H t, J 6.5, H-1), 2.37-2.24 (2H, m, H-8), 2.00-1.85 (2H, m, H-5), 1.60-1.48 (2H, m, H-2), 1.38-1.22 (4H, m, H-3, H-4), 1.04 (9H, s, $3 \times CH_3$, *tert* butyl).

^{13}C NMR (100 MHz, $CDCl_3$) δ [ppm]: 138.5, 138.3, 138.2, ($4 \times$ Ph-Cq), 135.6 ($4 \times$ Ph-CH), 134.1 ($2 \times$ Ph-Cq), 132.2 (CH, C-6), 129.5-127.5 ($26 \times$ Ph-CH), 124.7 (CH, C-7), 77.9 (CH, C-3'), 75.1 (CH, C-4'), 75.0 (CH, C-2'), 74.2 (Bn- CH_2), 73.7 (CH, C-5'), 73.4 (CH, C-1'), 73.3, 71.9, 71.5 ($3 \times$ Bn- CH_2), 69.4 (CH_2 , C-6'), 63.9 (CH_2 , C-1), 32.5 (CH_2 , C-2), 29.4 (CH_2 , C-4), 28.0 (CH_2 , C-8), 27.5 (CH_2 , C-5), 26.9 ($3 \times CH_3$, *tert*-butyl), 25.5 (CH_2 , C-3), 19.2 (Cq, *tert*-butyl).

IR $\tilde{\nu}$ [cm⁻¹]: 3088, 3011, 3067, 3030, 2930, 2858, 1605, 1589, 1496, 1471, 1455, 1361, 1208, 1110, 1027, 912, 823, 738.699, 613

HRMS (ESI) calculated for C₅₈H₇₂NO₆Si [M + NH₄]⁺: 906.5123, found. 906.5129.

6.2.25 8-(2',3',4',6'-Tetra-O-benzyl-1'-deoxy- α -D-mannopyranos-1'yl)-oct-6-en-1-ol **125**

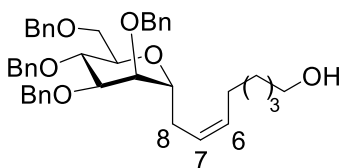

Compound **125** was prepared by adapting a published procedure for the removal of a TBDPS group.¹⁵⁶ Thus, to a solution of compound **138** (1 eq, 3.0 g, 3.4 mmol) in THF (50 ml) was added TBAF (2eq, 2.10 g, 6.70 mmol). The reaction mixture was kept stirring at rt under N₂ atmosphere and monitored by TLC (PE/EtOAc 75:25). After 2 h, the reaction was completed and the mixture concentrated in vacuum and purified by flash chromatography (PE/EtOAc 75:25) to give a colourless syrup of alcohol **125** (2.0 g, 3.1 mmol, 91%). R_f = 0.1 (PE/EtOAc 75:25).

$[\alpha]_D^{29} = +6.1$ (c 1.0, CH₃Cl).

¹H NMR (400 MHz, CDCl₃) δ [ppm]: 7.41-7.15 (20H, m, Ph-H), 5.50-5.38 (1H, m, H-6), 5.39-5.27 (1H, m, H-7), 4.73 (1H, d, J 11.2, Bn-H), 4.66-4.47 (7H, m, Bn-H), 4.01 (1H, td, J , 7.0, 4.5, H-1'), 3.87 (1H, t, J 7.0, H-4'), 3.83-3.74 (6H, m, H-3', H-5', H_A-6'), 3.71 (1H dd, J 9.9, 3.1, H_B-6), 3.67-3.62 (1H, m, H-2'), 3.57 (2H, t, J 6.6, H-1), 2.40-2.24 (2H, m, H-8), 2.02-1.91 (2H, m, H-5), 1.57-1.46 (2H, m, H-2), 1.42-1.24 (4H, m, H-4, H-3).

¹³C NMR (100 MHz, CDCl₃) δ [ppm]: 138.4, 138.3, 138.2 (4 \times Ph-Cq), 132.0 (CH, C-6), 128.4-127.5 (20 \times Ph-CH), 125.0 (CH, C-7), 77.6 (CH, C-3'), 75.1 (CH, C-2'), 75.0 (CH, C-4'), 74.1 (Bn-CH₂), 73.7 (CH, C-5'), 73.3 (Bn-CH₂), 73.2 (CH, C-1'), 72.0, 71.5 (2 \times Bn-CH₂), 69.3 (CH₂, C-6'), 62.9 (CH₂, C-1), 32.6 (CH₂, C-2), 29.3 (CH₂, C-4), 28.0 (CH₂, C-8), 27.4 (CH₂, C-5), 25.3 (CH₂, C-3).

IR $\tilde{\nu}$ [cm⁻¹]: 3445, 3063, 3088, 3030, 3007, 2926, 2860, 1605, 1496, 1454, 1314, 1208, 1091, 972, 912, 743, 697.

HRMS (ESI) calculated for C₄₂H₅₄NO₆ [M + NH₄]⁺: 668.3945, found. 668.3940.

6.2.26 8-(2',3',4',6'-Tetra-O-benzyl-1'-deoxy- α -D-mannopyranos-1'yl)-oct-6-en-1-(4-Toluenesulfonyloxy) **131**

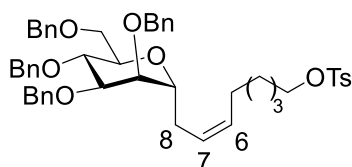

Tosylation of compound **125** was performed by adapting a published procedure.¹⁵⁷ Thus, to a solution of alcohol **125** (1 eq, 1.9 g, 3 mmol) in pyridine (24 ml), tosyl chloride (10 eq, 5.7 g, 30 mmol) was added at 0 °C. The reaction mixture was then stirred for 1 h under a N₂ atmosphere at rt and monitored by TLC (PE/EtOAc 75:25). After completion, the reaction mixture was co-evaporated three times with toluene. The crude product was purified by silica gel column chromatography (PE/EtOAc 90:10 → 80:20) to give **131** as a colourless syrup (2.2 g, 2.8 mmol, 93%). *R_f* = 0.2 (PE/EtOAc 75:25).

$[\alpha]_D^{18} = +14.1$ (*c* 1.9, CH₃Cl).

¹H NMR (400 MHz, CDCl₃) δ [ppm]: 7.77 (2H, d, *J* 8.0, Ph-H), 7.40-7.15 (22H, m, Ph-H), 5.42-5.27 (2H, m, H-6, H-7), 4.72 (1H, d, *J* 11.2, Bn-H), 4.64-4.47 (7H, m, Bn-H), 4.01 (2H, t, *J* 6.6, H-1), 3.87-3.81 (1H, m, H-1'), 3.89-3.84 (1H, m, H-4'), 3.83-3.74 (3H, m, H-3', H-5', H_B-6'), 3.71 (1H, dd, *J* 9.8, 3.1 H_A-6'), 3.65-3.61 (1H, m, H-2'), 2.42 (3H, s, Ts-CH₃), 2.28 (2H, m, H-8), 2.03-1.81 (2H, m, H-5), 1.66-1.53 (2H, m, H-2), 1.33-1.17 (4H, m, H-3, H-4).

¹³C NMR (100 MHz, CDCl₃) δ [ppm]: 144.6-133.2 (2 × Ph-Cq), 131.6 (CH, C-6), 129.8-127.5 (CH-Ph), 125.2 (CH, C-7), 77.5 (CH, C-3'), 75.1 (CH, C-2'), 75.0 (CH, C-4'), 74.0 (Bn-CH₂), 73.7 (CH, C-5'), 73.3 (Bn-CH₂), 73.2 (CH, C-1'), 72.0, 71.5 (2 × Bn-CH₂), 70.5 (CH₂, C-6'), 69.3 (C-1), 28.8 (C-8), 28.7 (C-5), 28.0 (C-4), 27.2 (C-2), 24.9 (C-3), 21.6 (Ts-CH₃).

IR $\tilde{\nu}$ [cm⁻¹]: 3062, 3029, 2925, 2859, 1654, 1597, 1495, 1453, 1358, 1306, 1207, 1188, 1175, 1096, 949, 814, 735, 697, 663, 575.

6.2.27 8-(1'-Deoxy- α -D-mannopyranos-1'yl)-oct-1-(4-Toluenesulfonyloxy)

132

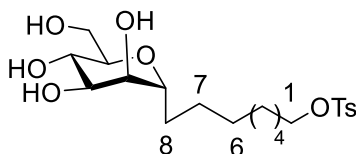

Compound **132** was prepared by adapting a published procedure.¹⁵⁸ Thus, Pd(OH)₂/C (400 mg) suspended in MeOH (25 ml) was added to a stirred mixture of compound **131** (1 eq, 1.9 g, 2.4 mmol) in EtOAc (25 ml). The reaction mixture was monitored by TLC (DCM/MeOH 15:1) and stirred overnight under H₂ atmosphere at rt. The mixture was filtered over Celite[®], and the filter pad was washed with MeOH (20 ml). The solution was concentrated under reduced pressure to give colourless oil **132** (0.8 g, 1.8 mmol, 75%). R_f = 0.1 (DCM/MeOH 15:1).

$[\alpha]_D^{18} = +7.7$ (*c* 4.5, CH₃OH).

¹H NMR (400 MHz, CD₃OD) δ [ppm]: 7.78 (2H, d, *J* 8.3, Ph-H), 7.44 (2H, d, *J* 8.1, Ph-H), 4.02 (2H, t, *J* 6.3, H-1), 3.87-3.81 (1H, m, H-1'), 3.79 (1H, dd, *J* 11.7, 2.7, H_A-6'), 3.75-3.59 (4H, m, H-2', H-3', H-4', H_B-6'), 3.40 (1H, ddd, *J* 8.2, 5.6, 2.6, H-5'), 2.45 (3H, s, CH₃-OTs), 1.80-1.67 (1H, m, H_A-8), 1.65-1.54 (2H, m, H-2), 1.50-1.20 (11H, m, H_B-8, H-3-H-7).

¹³C NMR (100 MHz, CD₃OD) δ [ppm]: 145.0, 133.2 (2 \times Ph-Cq), 129.7-127.6 (CH-Ph), 77.6 (CH, C-1'), 74.2 (CH, C-5'), 71.8, 71.5 (2 \times CH, C-2', C-3'), 70.7 (CH₂, C-1), 67.9 (CH, C-4'), 61.8 (CH₂, C-6'), 30.4, 30.2, 29.8, 29.6, 26.9, 26.8, 26.4 (7 \times CH₂, C-2-C-8), 21.6 (Ts-CH₃).

IR $\tilde{\nu}$ [cm⁻¹]: 3362, 3022, 2928, 2856, 1457, 1355, 1290, 1215, 1188, 1174, 1095, 1066, 957, 833, 814, 748, 662, 574, 554.

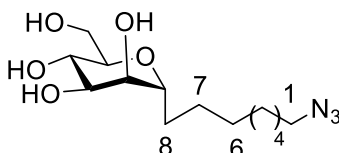
6.2.28 8-(1'-Deoxy- α -D-mannopyranos-1'yl)-oct-1-azide **133**

Azido compound **133** was prepared by adapting a published procedure.¹⁵⁹ Thus, to a solution of compound **132** (1 eq, 0.7 g, 1.65 mmol) in dry DMF (12 ml), NaN₃ (2 eq, 216 mg, 3.3 mmol)

was added. The reaction mixture was heated to 130 °C under N₂ atmosphere. The reaction mixture was monitored by TLC (DCM/MeOH 15:1) and kept stirring for 2 h. The reaction mixture was allowed to cool down to rt and taken between H₂O (50 ml) and EtOAc (150 ml). The organic phase was then washed with water (100 ml), dried and then concentrated in vacuum. The residue was purified by flash chromatography (DCM/MeOH 15:1) to give yellow oil **133** (440 mg, 1.40 mmol, 85%). R_f = 0.2 (DCM/MeOH 15:1).

$$[\alpha]_D^{29} = +4.5 \text{ (} c \text{ 1.0, CH}_3\text{OH)}.$$

¹H NMR (400 MHz, CD₃OD) δ [ppm]: 3.84 (1H, dt, *J* 12.2, 4.1, H-1'), 3.79 (1H, dd, *J* 11.6, 2.7, H_A-6'), 3.75-3.58 (4H, m, H-2', H-3', H-4', H_B-6'), 3.40 (1H, ddd, *J* 8.4, 5.7, 2.7, H-5'), 3.28 (2H, t, *J* 6.8, H-1) 1.81-1.69 (1H, m, H_A-8), 1.63-1.55 (2H, m, H-2), 1.53-1.23 (11H, m, H_B-8, H-3-H-7).

¹³C NMR (100 MHz, CD₃OD) δ [ppm]: 79.0 (CH, C-1'), 75.6 (CH, C-5'), 73.1, 72.9 (2 × CH, C-2', C-3'), 69.3 (CH, C-4'), 63.2 (CH₂, C-6'), 52.4 (CH₂, C-1), 30.5, 30.4, 30.2, 29.9, 29.6, 27.8, 26.9 (7 × CH₂, C-2-C-8).

IR $\tilde{\nu}$ [cm⁻¹]: 3390, 3014, 2930, 2856, 2096, 1464, 1348, 1259, 1157, 1123, 1069, 965, 910, 875, 838, 758, 666.

HRMS (ESI) calculated for C₁₄H₂₈N₃O₅ [M + H]⁺: 318.2023, found 318.2022.

6.2.29 Methyl 6-*O*-*tert*-Butyldiphenylsilyl- α -D-mannopyranoside **98**¹⁶⁷

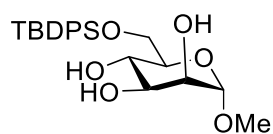

Compound **98** was prepared by adapting a published procedure. Thus, α -D-methylmannoside **66** (1 eq, 10 g, 51 mmol) was dissolved in anhydrous DMF (180 ml) followed by the addition of imidazole (2 eq, 6.9 g, 100 mmol). TBDPSCl (1.5 eq, 19 ml, 76 mmol) was added drop-wise to the stirred mixture at rt under N₂ atmosphere. The reaction was monitored by TLC (DCM/MeOH 20:1). After overnight stirring, the reaction was quenched with H₂O (900 ml) and extracted with EtOAc (1500 ml). The extract was washed with H₂O (2 × 500 ml) and then with brine (500 ml). The organic layer was dried, then concentrated under vacuum and purified by flash chromatography (DCM/MeOH 60:1 → 40:1) to give a colourless oil of **98** (18.4 g, 42 mmol, 82%). R_f = 0.17 (DCM/ MeOH 20:1).

$[\alpha]_D^{19} = +22.4$ (c 1.8, CHCl_3), reported: $[\alpha]_D^{27} = +23$ (c 1.5, CHCl_3).¹⁶⁸

^1H NMR (400 MHz, CD_3OD) δ [ppm]: 7.81-7.70 (4H, m, H-Ph), 7.47-7.35 (6H, m, H-Ph), 4.70 (1H, d, J 1.0, H-1), 4.05 (1H, dd, J 10.8, 1.7, H_A -6), 3.90-3.79 (2H, m, H_B -6, H-2), 3.67 (2H, ddd, J 10.8, 6.0, 2.5, H-3, H-4), 3.62-3.54 (1H, m, H-5), 3.43 (3H, s, H-OCH₃), 1.06 (2H, s, H-*tert*-butyl).

^{13}C NMR (100 MHz, CD_3OD) δ [ppm]: 136.8-136.8 (C-Ph), 134.9, 134.8 (C_q-Ph), 130.8-128.7 (C-Ph), 102.7 (C-1), 75.1 (C-4), 72.8 (C-3), 72.0 (C-2), 68.8 (C-5), 65.4 (C-6), 55.0 (C-OCH₃), 27.3 (3 \times CH₃, *tert*-butyl), 20.09 (C_q-*tert*-butyl). The NMR data was in accordance with the published data.

IR $\tilde{\nu}$ [cm^{-1}]: 3392, 3071, 3050, 2999, 2930, 2856, 1589, 1471, 1427, 1361, 1216, 1196, 1134, 1106, 1048, 962, 879, 800, 756, 701, 613, 504, 488.

6.2.30 Methyl 2,3,4-Tri-*O*-benzyl-6-*O*-*tert*-butyldiphenylsilyl- α -D-mannopyranoside **99**¹⁶⁷

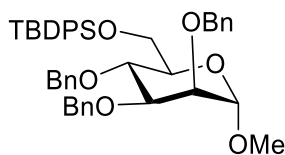

Benzylation of compound **98** was prepared by adapting a published procedure. Thus, compound **98** (1 eq, 10 g, 23 mmol) was dissolved in dry DMF (55 ml) under N_2 atmosphere. Benzyl bromide (4.5eq, 12.3 ml, 104 mmol) was added dropwise to the reaction solution. NaH (6 eq, 5.5 g as 60% dispersion in mineral oil, 138 mmol) was added to the stirred mixture at 0 °C in two portions to avoid excessive foaming due to the emergence of H_2 gas. Then, the mixture was allowed to warm to rt and stirred for 3h, by then, TLC analysis showed complete conversion of starting material to a major product and a side product (the perbenzylated methyl mannoside due to undesired cleavage of the TBDPS group during the reaction). The reaction was carefully quenched with MeOH and then diluted with EtOAc (500 ml). The organic phase was subsequently washed H_2O (250 ml) and brine (250 ml). The dried organic layer was concentrated under vacuum and purified by flash chromatography using (PE/EtOAc 20:1) giving a yellow syrup of **99** (8.0 g, 11.5 mmol, 50%). $R_f = 0.35$ (PE/EtOAc 9:1).

$[\alpha]_D^{19} = +21.2$ (c 2.0, CH_3Cl).

^1H NMR (400 MHz, CDCl_3) δ [ppm]: 7.70-7.58 (4H, m, H-Ph), 7.39-7.02 (21H, m, H-Ph), 4.82 (1H, d, J 10.8, Bn-H), 4.74-4.53 (5H, m, Bn-H), 4.48 (1H, d, J 11.0, H-1), 3.99-3.77 (4H, m, H-3, H-6, H-2), 3.76-3.68 (1H, m, H-4), 3.58 (1H, dd, J 9.7, 2.7, H-5), 3.22 (3H, s, H-OCH_3), 0.97 (9H, s, *tert*-butyl).

^{13}C NMR (100 MHz, CDCl_3) δ [ppm]: 138.8, 138.7, 138.6 ($3 \times \text{Ph-Cq}$), 136.0-135.8 ($10 \times \text{Ph-CH}$), 134.0, 133.6 ($2 \times \text{Ph-Cq}$), 129.6-127.6 ($15 \times \text{Ph-CH}$), 98.9 (C-1), 80.5 (C-2), 75.3 (C-4), 75.2 ($\text{CH}_2\text{-Ph}$), 74.9 (C-3), 73.2 (C-5), 72.8-72.3 ($\text{CH}_2\text{-Ph}$), 63.5 (C-6), 54.56 (C-O CH_3), 26.9 ($3 \times \text{CH}_3$, *tert*-butyl), 19.4 (Cq-*tert*-butyl). The NMR data was in accordance with the published data.

IR $\tilde{\nu}$ [cm^{-1}]: 3067, 3030, 2928, 2856, 2857, 1588, 1496, 1453, 1427, 1389, 1282, 1106, 1058, 1026, 862, 736, 697, 611, 503, 488.

6.2.31 Methyl 2,3,4-Tri-O-benzyl- α -D-mannoside **100**¹⁶⁷

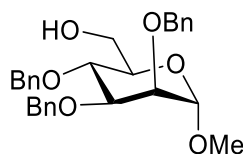

Compound **100** was prepared by adapting a published procedure. Thus, to a solution of compound **99** (1 eq, 6.0 g, 8 mmol) in THF (30 ml) TBAF (2eq, 5.4 g, 17mmol) was added, and the mixture was kept stirring at rt under N_2 atmosphere. The reaction mixture was monitored by TLC (PE/EtOAc 75:25), and the reaction was completed overnight and then concentrated in vacuum followed by purification by flash chromatography (PE/EtOAc 90:10 \rightarrow 75:25) to give a colourless syrup of **100** (2.9 g, 6 mmol, 75%). $R_f = 0.16$ (PE/EtOAc 75:25).

$[\alpha]_D^{19} = +34.2$ (c 1.6, CH_3Cl), reported: $[\alpha]_D^{25} = +34.8$ (c 0.28, CHCl_3).¹⁶⁹

^1H NMR (400 MHz, CD_3OD) δ [ppm]: 7.41-7.22 (15 H, m, H-Ph), 4.79-4.51 (7H, m, H-1, Bn-H), 3.88-3.82 (3H, m, H-2, H-6), 3.79 (1H, dd, J 11.9, 2.1, H-5), 3.68 (1H, dd, J 11.9, 5.4, H-4), 3.58-3.50 (1H, m, H-3), 3.34 (3H, s, H-O CH_3).

^{13}C NMR (100 MHz, CD_3OD) δ [ppm]: 139.9-139.6 ($3 \times \text{Ph-Cq}$), 129.4-128.7 ($15 \times \text{Ph-CH}$), 100.3 (C-1), 81.2 (C-2), 76.3 ($\text{CH}_2\text{-Ph}$), 75.9 (C-5), 75.91 ($\text{CH}_2\text{-Ph}$), 73.9 (C-4), 73.9 ($\text{CH}_2\text{-Ph}$), 72.9 (C-3), 62.6 (C-6), 55.2 (C-O CH_3). The NMR data was in accordance with the published data.

IR $\tilde{\nu}$ [cm^{-1}]: 3464, 3062, 3029, 2911, 1496, 1453, 1397, 1206, 1094, 1070, 1052, 1027, 909, 821, 799, 735, 697, 504.

6.2.32 Methyl 2,3,4-Tri-O-benzyl-6-O-tosyl- α -D-mannopyranose **101**¹⁷⁰

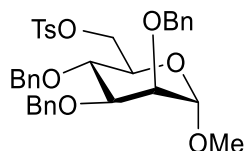

Tosylation of compound **100** at C-6 was prepared by adapting a published procedure. Thus, to a solution of compound **100** (1 eq, 2.6 g, 5.7 mmol) in pyridine (15 ml), DMAP (0.1 eq, 0.07 g, 0.6 mmol) and tosyl chloride (3 eq, 3.3 g, 17 mmol) were added at 0 °C. The reaction mixture was then stirred at rt overnight. TLC (PE/EtOAc 80:20) analysis showed complete conversion of starting material to a major product. The reaction was quenched with $\text{NH}_4\text{Cl}_{(\text{sat.})}$ (45 ml), and extracted between CHCl_3 (200 ml) and H_2O (100 ml). The aqueous layer was then re-extracted with CHCl_3 (2×100 ml). The combined organic layers were washed with NaHCO_3 (140 ml), followed by brine (140 ml). The organic phase was dried and then concentrated under vacuum and purified by flash chromatography (PE/EtOAc 80:20) giving a yellow syrup of **101** (3.2 g, 5.3 mmol, 93%). $R_f = 0.17$ (PE/EtOAc 80:20).

$[\alpha]_D^{19} = +35.5$ (c 1.8, CH_2Cl_2), reported: $[\alpha]_D^{25} = +34.4$ (c 1.1, CHCl_3).¹⁷¹

^1H NMR(400 MHz, CDCl_3) δ [ppm]: 7.73-7.08 (20 H, m, H-Ph), 4.83 (1H, d, J 10.8, Bn-H), 4.56 (6H, m, H-1, Bn-H), 4.23 (1H, dd, J 10.4, 1.7, H_A -6), 4.16 (1H, dd, J 10.4, 5.5, H_B -6), 3.84-3.64 (4 H, m, H-2, H-3, H-4, H-5), 3.20 (3H, s, H-OCH₃), 2.35 (3H, s, Ts-CH₃).

^{13}C NMR(100 MHz, CDCl_3) δ [ppm]: 144.6-138.0 ($5 \times \text{Ph-Cq}$), 133.0-127.6 ($20 \times \text{Ph-CH}$), 98.8 (C-1), 80.0 (C-2), 74.9 (CH_2 -Ph), 74.3 (C-4), 74.1 (C-5), 72.7-72.0 ($2 \times \text{CH}_2$ -Ph), 69.9 (C-3), 69.2 (C-6), 54.9 (C-OCH₃), 21.6 (C-CH₃). The NMR data was in accordance with the published data.

IR $\tilde{\nu}$ [cm^{-1}]: 3062, 3030, 2918, 2890, 1597, 1496, 1362, 1307, 1189, 1175, 1094, 1066, 1026, 965, 928, 865, 814, 737, 697, 667, 588, 553.

6.2.33 Methyl 2,3,4-Tri-O-benzyl- α -D-rhamnopyranoside **102**⁸⁵

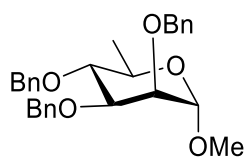

D-Rhamnoside **102** was prepared by adapting a published procedure. Thus, LAH (5 eq, 0.9 g, 24.2 mmol) was added to Et₂O (20 ml) at 0 °C (ice bath). Compound **101** (1 eq, 3.0 g, 4.8 mmol) was dissolved in Et₂O (40 ml) and the mixture cooled to 0 °C (ice bath). The cooled solution of **101** was added very slowly to the solution of LAH at 0 °C. After complete addition, the ice bath was removed. Then the reaction mixture was heated and kept under reflux for 1 h (TLC: PE/EtOAc 80:20). The mixture was quenched with potassium sodium tartrate tetrahydrate (100 ml) and diluted with EtOAc (200 ml). Precipitates were filtered off and the solution concentrated under vacuum. The crude product was purified by flash chromatography (PE/EtOAc 95:5 → 80:20) to give colourless syrup **102** (1.6 g, 3.6 mmol, 74%). $R_f = 0.12$ PE/EtOAc 95:5). $[\alpha]_D^{19} = +30.4$ (c 2.1, CH₃Cl), reported: $[\alpha]_D^{25} = +27.1$ (c 1.4, CHCl₃).

¹H NMR(400 MHz, CDCl₃) δ [ppm]: 7.36-7.18 (15H, m, H-Ph), 4.90 (1H, d, J 10.9, Bn-H), 4.69 (2H, d, J 5.8, H-1, Bn-H), 4.62-4.53 (4H, m, Bn-H, H-1), 3.78 (1H, dd, J 8.9, 3.1, H-2), 3.75-3.70 (1H, m, H-4), 3.66-3.52 (2H, m, H-3, H-5), 3.24 (3 H, s, H-OCH₃), 1.29 (3 H, d, J 5.9, H-6).

¹³C NMR(100 MHz, CDCl₃) δ [ppm]: 138.6-138.3 (3 × Ph-Cq), 128.3-127.5 (15 × Ph-CH), 99.0 (C-1), 80.4 (C-5), 80.1 (C-2), 75.3 (CH₂-Ph), 74.7 (C-4), 72.8 (CH₂-Ph), 72.1 (CH₂-Ph), 67.8 (C-3), 54.6 (C-CH₃), 17.9 (C-CH₃). The NMR data was in accordance with the published data.

IR $\tilde{\nu}$ [cm⁻¹]: 3088, 3063, 3030, 2973, 2909, 2833, 1496, 1454, 1383, 1246, 1207, 1174, 1120, 1090, 1064, 1028, 972, 910, 799, 736, 697, 637.

6.2.34 3-(1'-Deoxy-2',3',4'-tri-O-benzyl- α -D-rhamnopyranose-1'-yl)-1-propene **103**

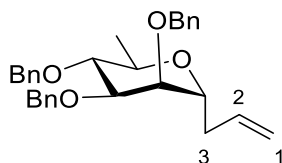

Allylation of compound **102** was prepared by adapting a published procedure.¹⁷² Thus, methyl benzylated rhamnoside **102** (1 eq, 1.45 g, 3.2 mmol) was dissolved in dry CH₃CN (10 ml) under N₂ atmosphere. Allyltrimethylsilane (2.7 eq, 1.3 ml, 7.8 mmol) and TMSOTf (0.6 eq, 0.3 ml, 1.74 mmol) were added sequentially at 0 °C to the reaction mixture. The reaction mixture was monitored by TLC (PE/EtOAc 9:1), and went to completion overnight. The reaction mixture was quenched by addition of saturated NaHCO_{3(aq)} (20 ml) and diluted with diethyl ether (70 ml). The aqueous layer was then extracted with diethyl ether (2 × 40 ml). The combined organic phases were dried and then concentrated under vacuum and purified by flash chromatography (Hex/ EtOAc 99:1 → 95:5) giving the title compound **103** as a colourless oil (1.3 g, 2.8 mmol, 86%). R_f = 0.4 (PE/EtOAc 80:20).

$[\alpha]_D^{23} = +8.2$ (*c* 5.0, CH₃Cl).

¹H NMR (400 MHz, CDCl₃) δ [ppm]: 7.51-7.08 (15H, m, Ph-H), 5.68 (1H, ddt, *J* 17.1, 10.3, 6.9, H-2), 5.05-4.94 (2H, m, H-1), 4.70 (1H, d, *J* 11.1, Bn-H), 4.64-4.50 (5H, m, 5 × Bn-H), 4.02 (1H, td, *J* 7.4, 3.5, H-1'), 3.74 (1H, dd, *J* 7.9, 3.1, H-3'), 3.68 (1H, dd, *J* 13.5, 6.6, H-5'), 3.62 (1H, t, *J* 3.3, H-2'), 3.58 (1H, t, *J* 7.7, H-4'), 2.35 (1H, dt, *J* 14.7, 7.4, H_A-3), 2.22 (1H, m, H_B-3), 1.32 (1H, d, *J* 6.2, H₃-6').

¹³C NMR (100 MHz, CDCl₃) δ [ppm]: 138.5, 138.3, 138.3 (3 × Ph-Cq), 134.2 (C-1), 128.4-127.6 (15 × Ph-CH), 117.2 (C-2), 80.2 (C-4'), 77.9 (C-2'), 75.2 (C-3'), 74.6 (Bn-CH₂), 72.9 (C-1'), 71.9, 71.7 (2 × Bn-CH₂), 69.7 (C-5'), 34.3 (C-3), 18.1 (C-6').

IR $\tilde{\nu}$ [cm⁻¹]: 3063, 3029, 2975, 2916, 2866, 1605, 1496, 1453, 1360, 1310, 1207, 1093, 1027, 997, 914, 822, 776, 735, 697, 609, 550.

HRMS (ESI) calculated for C₃₀H₃₅O₄ [M + H]⁺: 459.2529, found 459.2528.

6.2.35 Methyl 6-O-tosyl- α -D-mannoside **106**¹⁷³

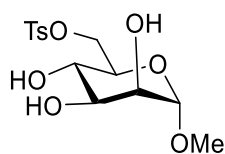

Compound **106** was prepared by adapting a published procedure. Thus, tosyl chloride (1.2 eq, 5.9 g, 30.8 mmol) was added in portions to a solution of methyl mannoside **66** (1 eq, 5.0 g, 25.7 mmol) and DMAP (0.1 eq, 0.3 g, 2.6 mmol) in pyridine (50 ml) at 0 °C. The reaction mixture was stirred at rt overnight under N₂ atmosphere (TLC: DCM/MeOH 20:1). Then, the reaction mixture was co-evaporated with toluene (3×). The crude was then purified by flash chromatography (DCM/MeOH 40:1 → 20:1) to give a colourless syrup of **106** (8.0 g, 23.2 mmol, 90%). *R_f* = 0.19 (DCM/MeOH 20:1).

$[\alpha]_D^{19} = +46.0$ (*c* 2.0, CH₃OH).

¹H (400 MHz, CD₃OD) δ [ppm]: 7.85 (2H, d, *J* 8.3, H-Ph), 7.43 (2H, d, *J* 8.3, H-Ph), 4.55 (1H, app. s, H-1), 4.35 (1H, d, *J* 10.5, H_A-6), 4.16 (1H, dd, *J* 10.6, 6.9, H_B-6), 3.79-3.72 (1H, m, H-2), 3.67-3.55 (2H, m, H-5, H-3), 3.54-3.48 (1H, m, H-4), 3.29 (3H, s, Ts-CH₃), 2.45 (3H, s, H-CH₃).

¹³C (100 MHz, CD₃OD) δ [ppm]: 146.4, 134.4 (2 × Ph-Cq), 130.9 (C-Ph), 129.1 (C-Ph), 102.7 (C-1), 72.4 (C-3), 71.9 (C-5), 71.8 (C-2), 71.3 (C-6), 68.2 (C-4), 55.3 (C-OMe), 21.6 (C-Ts-CH₃). The NMR data was in accordance with the published data.

IR $\tilde{\nu}$ [cm⁻¹]: 3397, 2927, 2838, 1635, 1599, 1495, 1450, 1401, 1358, 1293, 1190, 1176, 1136, 1097, 1062, 957, 834, 815, 677, 554, 516.

6.2.36 Methyl- α -D-rhamnopyranose **107**

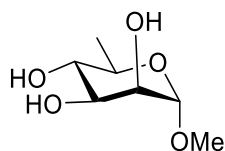

Methyl- α -D-rhamnopyranose **107** was prepared by adapting a published procedure.¹⁷⁴ Thus, a suspension of LAH (5 eq, 4.0 g, 114.5 mmol) in THF (250 ml) was prepared at 0 °C (ice bath). A cooled solution of tosylate **106** (1 eq, 8.0 g, 23 mmol) in THF (40 ml) was added slowly to the suspension of LAH at 0 °C. The ice bath was removed, and the mixture heated to

reflux temperature. The reaction was kept under reflux and monitored by TLC (DCM/MeOH 5:1). After 3 h, the reaction was quenched slowly with a solution of $\text{Na}_2\text{SO}_4(\text{sat.}) \cdot 10\text{H}_2\text{O}$. Precipitates were removed by filtration and the remaining solution was dried and concentrated. The crude product was purified by flash column chromatography (DCM/MeOH 10:1) to give colourless syrup of D-rhamnoside **107** (3.8 g, 21.6 mmol 94%). $R_f = 0.4$ (DCM/MeOH 5:1).

$$[\alpha]_D^{21} = +91.4 \text{ (} c \text{ 1.0, CH}_3\text{OH)}.$$

$^1\text{H NMR}$ (400 MHz, CD_3OD) δ [ppm]: 4.58 (1H, s, H-1), 3.74 (1H, d, J 1.5, H-2), 3.67-3.50 (3H, m, H-4, H-3, H-5), 3.37 (3H, s, OCH_3), 1.29 (3H, d, J 6.2, H-6).

$^{13}\text{C NMR}$ (100 MHz, CD_3OD) δ [ppm]: 102.8 (C-1), 73.9 (C-3), 72.4 (C-4), 72.2 (C-2), 69.6 (C-5), 55.1 (C- OCH_3), 17.9 (C-6).

IR $\tilde{\nu}$ [cm^{-1}]: 3358, 2935, 2838, 1450, 1384, 1228, 1198, 1131, 1096, 1048, 986, 969, 910, 880, 809, 751, 667, 534.

6.2.37 2-(1'-Deoxy-2',3',4'-tri-O-benzyl- α -D-rhamnopyranose-1'-yl)ethanal **143**

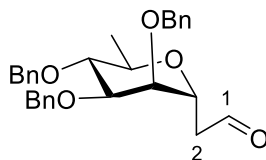

The aldehyde **143** was prepared by adapting a published procedure.¹⁵⁴ Thus, under dry conditions, D-rhamnosyl propene derivative **103** (1 eq, 9.0 g, 19.6 mmol) was dissolved in dry DCM (200 ml). Ozonized oxygen was bubbled at $-78\text{ }^\circ\text{C}$ through this mixture. The end of the reaction (after 23 min) was indicated by the persistence of a blue colour due to excess of ozone in the solution and the ozone stream stopped. The reaction was continued to be stirred until the blue colour had disappeared. Then PPh_3 (1.5 eq, 7.7 g, 29 mmol) was added to the stirred mixture and the reaction was allowed to slowly warm up to $0\text{ }^\circ\text{C}$. The reaction mixture was monitored by TLC (PE/EtOAc 80:20). The crude compound was concentrated under reduced pressure after removing the cooling bath. The compound was isolated and purified by flash chromatography (PE/ EtOAc 90:10 \rightarrow 80:20) to give a colourless syrup of aldehyde **143** (8.4 g, 18.2 mmol, 93%). $R_f = 0.27$ (PE/EtOAc 80:20).

$$[\alpha]_D^{23} = +14 \text{ (} c \text{ 5.0, CH}_3\text{Cl)}.$$

^1H NMR (400 MHz, CDCl_3) δ [ppm]: 9.72 (1H, t, J 2.1, H-1), 7.39-7.23 (15H, m, $15 \times \text{Ph-H}$), 4.64 (1H, d, J 11.8, Bn-H), 4.58-4.53 (5H, m, H-1', $4 \times \text{Bn-H}$), 4.50 (1H, d, J 11.9, Bn-H), 3.89-3.81 (1H, m, H-5'), 3.78 (1H, dd, J 5.5, 3.0, H-3'), 3.60 (1H, dd, J 6.6, 3.0, H-2'), 3.54 (1H, t, J 5.1, H-4'), 2.67-2.60 (2H, m, H-2), 1.38 (3H, d, J 6.8, H₃-6').

^{13}C NMR (100 MHz, CDCl_3) δ [ppm]: 200.5 (CHO, C-1), 138.1, 138.0, 137.8 ($3 \times \text{Ph-C}_q$), 128.5, 128.4, 128.3, 128.1, 127.9, 127.8, 127.8 ($15 \times \text{Ph-CH}$), 78.5 (C-4'), 75.9 (C-2'), 75.3 (C-3'), 73.2 (Bn- CH_2), 72.4 (Bn- CH_2), 71.5 (Bn- CH_2), 71.0 (C-5'), 66.1 (C-1'), 45.1 (CH_2 , C-2), 17.2 (C-6').

IR $\tilde{\nu}$ [cm^{-1}]: 3088, 3064, 3031, 2992, 2975, 2906, 2868, 2735, 1718, 1604, 1544, 1496, 1453, 1363, 1297, 1207, 1175, 1067, 741, 633.

Storage: No further analytical data. This compound needs to be stored at $-18\text{ }^\circ\text{C}$.

6.2.38 8-(2',3',4'-Tri-O-benzyl-1'-deoxy- α -D-rhamnopyranos-1'yl)-oct-6-en-1-(*tert*-butyldiphenylsilyloxy) 144

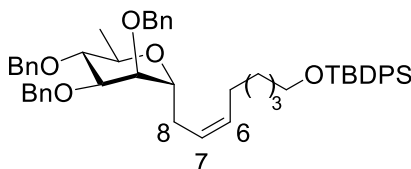

This Wittig coupling **144** was prepared by adapting a published procedure.¹⁵⁵ Thus, Wittig salt **83** (2 eq, 20.0 g, 27.70 mmol) in dry THF (100 ml) and dry DMPU (30 ml) were cooled to $-78\text{ }^\circ\text{C}$ under N_2 atmosphere. LiHMDS (2 eq, 28 ml, 27.70 mmol) was added drop-wise to the reaction mixture to keep the temperature below $-70\text{ }^\circ\text{C}$, while the mixture turned bright orange. Then a solution of aldehyde **143** (1 eq, 6.4 g, 13.8 mmol) in dry THF (25 ml) was added slowly to the stirred mixture. The reaction mixture was monitored by TLC (PE/EtOAc 90:10). The mixture was allowed to slowly reach to $0\text{ }^\circ\text{C}$. before quenched with 1M NH_4Cl (30 ml). After dilution with Et_2O (2×300 ml), washing with water (2×100 ml), the organic phase was dried and concentrated under vacuum then the residue purified by flash chromatography (PE /EA 90:10) to give colourless oil **144** (4.8 g, 6.2 mmol, 46%). $R_f = 0.34$ (PE/EtOAc 90:10).

$[\alpha]_D^{29} = +8.3$ (c 3.0, CH_3Cl).

^1H NMR (400 MHz, CDCl_3) δ [ppm]: 7.67 (4H, "dd", 7.7, 1.6, Ph-H), 7.46-7.22 (21H, m, Ph-H), 5.42 (1H, dt, 17.8, 7.2, H-6), 5.25 (1H, dt, 17.4, 7.3, H-7), 4.88 (1H, d, J 11.0, Bn- CH_2), 4.70-4.60 (3H, m, $3 \times$ Bn- CH_2), 4.57 (1H, d, J 12.0, Bn-H), 4.53 (1H, d, J 12.0, Bn- CH_2), 3.98 (1H, td, J 7.3, 2.5, H-1'), 3.75 (1H, dd, J 8.0, 2.9, H-3'), 3.69-3.56 (5H, m, H-2', H-4', H-5', H-1), 2.35-2.20 (2H, m, H-8), 1.98-1.85 (2H, m, H-5), 1.60-1.49 (2H, m, H-2), 1.39-1.24 (4H, m, H-4, H-3), 1.35 (3H, d, J 5.9, H-6'), 1.05 (9H, s, *tert*-butyl).

^{13}C NMR (100 MHz, CDCl_3) δ [ppm]: 138.5, 138.4, 138.3 ($3 \times$ Ph-Cq), 135.5 (Ph-CH), 134.1 (Ph-Cq), 129.5 (C-6), 128.4-127.6 (Ph-CH), 124.6 (C-7), 80.6 (C-4'), 78.9 (C-3'), 75.2 (C-2'), 75.1 (Bn- CH_2), 74.3 (C-1'), 72.0, 71.9 ($2 \times$ Bn- CH_2), 69.8 (C-5'), 63.9 (C-1), 32.6 (C-2), 29.5 (C-4), 27.9 (C-8), 27.6 (C-5), 26.9 ($3 \times$ CH_3 , *tert*-butyl), 25.5 (C-3), 19.2 (Cq, *tert*-butyl), 18.3 (C-6').

IR $\tilde{\nu}$ [cm^{-1}]: 3088, 3067, 3029, 2931, 2858, 1496, 1471, 1454, 1428, 1389, 1360, 1207, 1111, 1028, 910, 823, 737, 700, 613.

HRMS (ESI) calculated for $\text{C}_{51}\text{H}_{66}\text{NO}_5\text{Si}$ [$\text{M} + \text{NH}_4$] $^+$: 800.4704, found. 800.4716.

6.2.39 8-(2',3',4'-Tri-O-benzyl-1'-deoxy- α -D-rhamnopyranos-1'yl)-oct-6-en-1-ol **127**

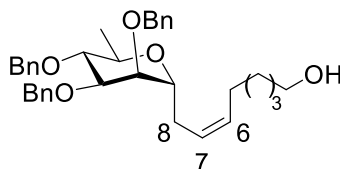

Compound **127** was prepared by adapting a published procedure for the removal of a TBDPS group.¹⁵⁶ Thus, to a solution of compound **144** (1 eq, 800 mg, 1 mmol) in THF (7 ml) was added TBAF (2 eq, 640 mg, 2 mmol). The reaction mixture was stirred at rt for 1 h under N_2 atmosphere and monitored by TLC (PE/EtOAc 80:20). The resulting mixture was concentrated under vacuum and purified by flash chromatography (PE /EA 80:20 \rightarrow 70:30) to give colourless oil of alcohol **127** (0.5 g, 0.91 mmol, 91%). $R_f = 0.1$ (PE/EA 80:20).

$[\alpha]_D^{22} = +7.6$ (c 2.5, CH_3Cl).

^1H NMR (400 MHz, CDCl_3) δ [ppm]: 7.40-7.24 (15H, m, H-Ph), 5.48-.5.39 (1H, m, H-6), 5.32-5.23 (1H, m, H-7), 4.85 (1H, d, J 11.0, Bn-H), 4.68 (1H, d, J 12.4 Bn-H), 4.65-4.60 (3H, m, Bn-H), 4.58 (1H, d, J 12.2, Bn-H), 4.51 (1H, d, J 12.3, Bn-H), 3.98 (1H, td, J 7.4, 3.0, H-1'),

3.76 (1H, dd, *J* 8.0, 3.1, H-3'), 3.70-3.65 (2H, m, H-2', H-5'), 3.62-3.56 (3H, m, H-4', H-1), 2.35-2.20 (2H, m, H-8), 2.02-1.89 (2H, m, H-5), 1.60-1.49 (2H, m, H-2), 1.38-1.333 (4H, m, H-4, H-3). 1.33 (3H, d, *J* 6.1, H-6').

¹³C NMR (100 MHz, CDCl₃) δ [ppm]: 138.4, 138.35, 138.3 (3 × Ph-Cq), 132.0 (C-6), 128.4-127.6 (15 × Ph-CH), 124.9 (C-7), 80.3 (C-4'), 78.6 (C-3'), 75.1 (C-2'), 74.8 (Bn-CH₂), 73.9 (C-1'), 71.9, 71.7 (2 × Bn-CH₂), 69.7 (C-5'), 62.8 (C-1), 32.6 (C-2), 29.3 (C-4), 27.7 (C-8), 27.4 (C-5), 25.3 (C-3), 18.2 (C-6').

IR $\tilde{\nu}$ [cm⁻¹]: 3445, 3088, 3063, 3030, 3007, 2931, 2860, 1645, 1496, 1454, 1360, 1247, 1207, 1114, 1092, 1075, 1028, 911, 736, 697, 666.

HRMS (ESI) calculated for C₃₅H₄₅O₅ [M + H]⁺: 545.3261 found. 545.3252.

6.2.40 8-(2',3',4'-Tri-O-benzyl-1'-deoxy- α -D-rhamnopyranos-1'yl)-oct-6-en-1-(4-tosyl) **134**

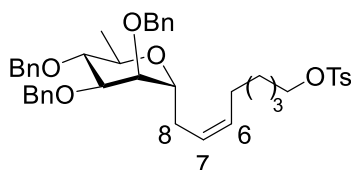

Compound **134** was prepared by adapting a published procedure.¹⁵⁷ Thus, to a solution of alcohol **127** (1 eq, 3.0 g, 5.5 mmol) in pyridine (30 ml), tosyl chloride (10 eq, 10.6 g, 56 mmol) was added at 0 °C. The reaction mixture was stirred at rt for 1 h under N₂ atmosphere (TLC: PE/EtOAc 70:30) before co-evaporation with toluene (3×). The crude material was then purified by flash chromatography (PE/EtOAc 90:10 → 80:20) to give a colourless syrup of tosylate **134** (3.6 g, 5.2 mmol, 95%). *R_f* = 0.46 (PE/EtOAc 70:30).

$[\alpha]_D^{22} = +8.3$ (*c* 3.0, CH₃Cl).

¹H NMR (400 MHz, CDCl₃) δ [ppm]: ¹H 7.78 (2H, d, *J* 8.2, Ph-H), 7.38-7.25 (17H, m, Ph-H), 5.42-5.32 (1H, m, H-6), 5.30-5.21 (1H, m, H-7), 4.86 (1H, d, *J* 11.0, Bn-H), 4.72 (1H, d, *J* 12.4, Bn-H), 4.65-4.59 (3H, m, Bn-H), 4.58 (1H, d, *J* 12.6, Bn-H), 4.52 (1H, d, *J* 12.2, Bn-H), 4.00 (2H, t, *J* 6.5, H-1), 3.95 (1H, dd, *J* 7.4, 3.0, H-1'), 3.74 (1H, dd, *J* 7.9, 3.0, H-3'), 3.69-3.55 (3H, m, H-2', H-4', H-5'), 2.44 (3H, s, OTs-CH₃), 2.32-2.17 (2H, m, H-8), 1.97-1.83 (2H, m, H-5), 1.66-1.56 (2H, m, H-2), 1.33 (3H, d, *J* 6.0, H-6'), 1.30-1.22 (4H, m, H-4, H-3).

^{13}C NMR (100 MHz, CDCl_3) δ [ppm]: 144.6, 138.4, 138.3, 138.2, 133.2, ($5 \times \text{Ph-Cq}$), 131.6 (C-6), 129.8-127.6 ($19 \times \text{Ph-CH}$), 125.1 (C-7), 80.3 (C-4'), 78.5 (C-3'), 75.1 (C-2'), 74.8 (Bn- CH_2), 73.9 (C-1'), 71.9, 71.7 ($2 \times \text{Bn-CH}_2$), 70.5 (C-1), 69.7 (C-5'), 28.8 (C-4), 28.7 (C-2), 27.7 (C-8), 27.2 (C-5), 24.9 (C-3), 21.6 (Ts- CH_3), 18.2 (C-6').

IR $\tilde{\nu}$ [cm^{-1}]: 3062, 3029, 2970, 2928, 2860, 1598, 1495, 1453, 1356, 1306, 1291, 1208, 1188, 1174, 1094, 1074, 948, 814, 735, 697, 663, 554.

6.2.41 8-(1'-Deoxy- α -D-rhamnopyranos-1'yl)-oct-1-(4-tosyl) **135**

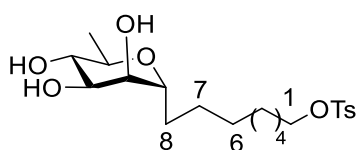

Hydrogenation of compound **134** was prepared by adapting a published procedure.¹⁵⁸ Thus, $\text{Pd}(\text{OH})_2/\text{C}$ (600 mg) suspended in MeOH (25 ml) was added to a stirred mixture of benzylated compound **134** (1 eq, 3.6 g, 5.1 mmol) in EtOAc (25 ml). The reaction mixture was set under H_2 atmosphere and stirred at rt overnight (TLC: DCM/MeOH 10:1). Then, the mixture was filtered over Celite[®] and the filter pad washed with MeOH (20 ml). The solution was concentrated under reduced pressure to give colourless oil of the deprotected tosylate **135** (2.2 g, 4.9 mmol, 96%). $R_f = 0.44$ (DCM/MeOH 10:1).

$[\alpha]_D^{22} = +11$ (c 1.6, CH_3OH).

^1H NMR (400 MHz, CD_3OD) δ [ppm]: 7.78 (2H, d, J 8.2, Ar-H), 7.45 (2H, d, J 8.1, Ar-H), 4.02 (2H, t, J 6.3, H-1), 3.77 (1H, br d, J 8.3, H-1'), 3.74-3.71 (1H, m, H-2'), 3.61 (1H, dd, J 8.7, 3.2, H-3'), 3.48-3.41 (1H, m, H-5'), 3.40-3.35 (1H, m, H-4'), 2.46 (3H, s, Ts- CH_3), 1.81-1.66 (1H, m, H_A -8), 1.65-1.55 (2H, m, H-2), 1.47-1.26 (11H, m, H-3- H_B -8), 1.25 (3H, d, J 5.9, H-6').

^{13}C NMR (100 MHz, CD_3OD) δ [ppm]: 146.4, 134.7 ($2 \times \text{Ar-Cq}$), 131.0, 128.9 ($2 \times \text{Ar-CH}$), 79.1 (C-1'), 74.5 (C-4'), 73.3 (C-2'), 72.7 (C-3'), 72.0 (C-1), 70.7 (C-5'), 30.4, 30.3, 29.9, 29.8, 29.6, 27.1, 26.4 ($7 \times \text{CH}_2$, C-2-C-8), 21.6 (Ts- CH_3), 18.4 (C-6').

IR $\tilde{\nu}$ [cm^{-1}]: 3374, 3080, 2928, 2856, 1495, 1435, 1355, 1214, 1188, 1174, 1122, 1095, 1061, 937, 814, 750.662.

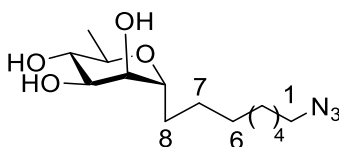
6.2.42 8-(1'-Deoxy- α -L-rhamnopyranos-1'yl)-oct-1-azide **136**

Azido compound **136** was prepared by adapting a published procedure.¹⁵⁹ Thus, to a solution of tosylate **135** (1 eq, 2.0 g, 4.6 mmol) in dry DMF (20 ml), NaN₃ (3 eq, 0.9 g, 14 mmol) was added. The reaction mixture was heated to 130 °C under N₂ atmosphere for 1.5 h and monitored by TLC (DCM/MeOH 10:1) every 30 min. After the reaction mixture had been allowed to cool down to rt and taken between H₂O (100 ml) and EtOAc (300 ml). The organic phase was then washed with water (150 ml), dried and concentrated in vacuum. The residue was purified by flash chromatography (DCM/MeOH 30:1) to give azide **136** as a yellow oil (1.2 g, 4 mmol, 86%). *R_f* = 0.35 (DCM/MeOH 10:1).

$[\alpha]_D^{22} = +7.2$ (*c* 1.0, CH₃OH).

¹H NMR (400 MHz, CD₃OD) δ [ppm]: 3.77 (1H, d, *J* 8.6, H-1'), 3.74-3.70 (1H, m, H-2'), 3.60 (1H, dd, *J* 8.7, 3.3, H-3'), 3.49-3.34 (2H, m, H-4', H-5'), 3.27 (2H, t, *J* 6.8, H-1), 1.80-1.69 (1H, m, H_A-8), 1.64-1.53 (2H, m, H-2), 1.49-1.28 (11H, m, H_B-8, H-3-H-7), 1.24 (3H, d, *J* 6.0, H-6').

¹³C NMR (100 MHz, CD₃OD) δ [ppm]: 79.1 (C-1'), 74.5 (C-4'), 73.3 (C-2'), 72.8 (C-3'), 70.8 (C-5'), 52.5 (C-1), 30.5, 30.3, 30.2 (3 \times CH₂, C-4, C-5, C-6), 29.9 (C-2), 29.6 (C-8), 27.8 (C-3), 27.1 (C-7), 18.4 (C-6').

IR $\tilde{\nu}$ [cm⁻¹]: 3371, 2931, 2856, 2095, 1648, 1459, 1380, 1347, 1260, 1062, 972, 902, 876, 825, 757, 723, 653.

HRMS (ESI) calculated for C₁₄H₂₈N₃O₄ [M + H]⁺: 302.2074, found 302.2074.

6.2.43 8'-((1,2,3-triazol)-4-yl)methoxyethoxyethanthioacetate)-1-C- α -L-rhamnopyranose **173**

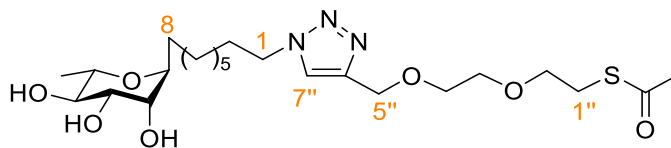

Compound **173** was prepared by adapting a published procedure.¹⁷⁵ Thus, an aqueous solution of CuSO₄ (0.2 eq, 53 mg, 0.21 mmol) and an aqueous solution of sodium ascorbate (0.8 eq, 168 mg, 0.85 mmol) in H₂O (250 μ l) were added subsequently to a yellow solution of compound **130** (1 eq, 200 mg, 0.66 mmol) and compound **171** (1.5 eq, 215 mg, 1.06 mmol) in DMF (1.7 ml). The reaction was monitored by TLC (DCM/MeOH 10:1, samples were quenched in EtOAc and H₂O before applied to TLC plate) and full conversion showed after 30 min. The reaction mixture was then concentrated in vacuum. The crude was purified by flash chromatography (DCM/MeOH 10:0.5 \rightarrow 10:1) to give a colourless syrup (285 mg, 0.56 mmol, 85%). $R_f = 0.24$ (DCM/MeOH 10:0.5).

$[\alpha]_D^{22} = -4.2$ (c 6.8, CH₃OH).

¹H NMR (500 MHz, CD₃OD) δ [ppm]: 7.98 (1H, s, H-7''), 4.63 (2H, s, H-5''), 4.40 (2H, t, J 7.1, H-1), 3.76 (1H, dt, J 10.9, 5.8, H-1'), 3.74-3.70 (1H, m, H-2'), 3.66-3.59 (5H, m, H-3', H-3'', H-4''), 3.56 (2H, t, J 6.5, H-2''), 3.46-3.33 (2H, m, H-4', H-5'), 3.05 (2H, t, J 6.5, H-1''), 2.31 (3H, s, SAc-CH₃), 1.94-1.85 (2H, m, H-2), 1.79-1.68 (1H, m, H_A-8), 1.45-1.26 (11H, m, H_B-8, H-3-H-7), 1.24 (3H, d, J 6.0, H-6').

¹³C NMR (125 MHz, CD₃OD) δ [ppm]: 195.6 (CO, SAc), 144.6 (C_q, C-6''), 123.7 (C-7''), 77.7 (CH, C-1'), 73.1 (CH, C-5'), 71.9 (CH, C-2'), 71.4 (CH, C-3'), 69.9 (CH₂, C-2''), 69.5, 69.4 (2 \times CH₂, C-3'', C-4''), 69.3 (CH, C-4'), 63.7 (CH₂, C-5''), 49.9 (CH₂, C-1), 29.9 (CH₂, C-2), 29.2 (CH₃-SAc), 29.1, 28.9, 28.6, 28.3, 28.2, 26.1, 25.7 (6 \times CH₂, C-3-C-8, C-1''), 17.1 (C-6').

IR $\tilde{\nu}$ [cm⁻¹]: 3387, 3150, 2927, 2856, 1688, 1452, 1354, 1291, 1221, 1188, 1176, 1087, 1056, 960, 819, 776, 723, 660, 625, 554, 532, 481.

HRMS (ESI) calculated for C₂₃H₄₂N₃O₇S [M + H]⁺: 504.2738, found. 504.2729.

6.2.44 8'-((1,2,3-Triazol-4-yl)methoxyethoxyethanthioacetate)-1-C- α -D-mannopyranose **174**

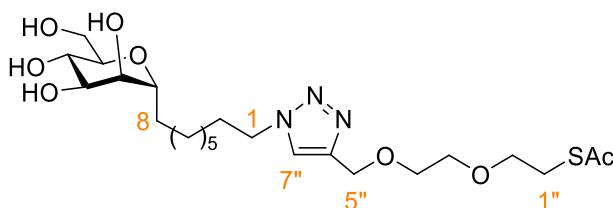

The click reaction of compound **174** was performed by adapting a published procedure.¹⁷⁵ Thus, an aqueous solution of CuSO₄ (0.2 eq, 30 mg, 0.114 mmol) and an aqueous solution of sodium ascorbate (0.8 eq, 90 mg, 0.46 mmol) in H₂O (300 μ l) were added subsequently to the yellow solution of compound **133** (1 eq, 120 mg, 0.38 mmol) and compound **171** (1.5 eq, 115 mg, 0.57 mmol) in DMF (1.7 ml). The reaction was monitored by TLC (DCM/MeOH 10:2, samples were quenched in EtOAc and H₂O before being applied to TLC plate). Full conversion was achieved after 15 min. The reaction mixture was diluted with EtOAc (25 ml) and H₂O (5 ml). The organic phase was washed with brine (5 ml) and then dried and concentrated under vacuum. The crude product was purified by flash chromatography (DCM/MeOH 10:1) to give a colourless syrup (125 mg, 0.24 mmol, 64%). $R_f = 0.1$ (DCM/MeOH 10:0.5).

$$[\alpha]_D^{22} = +11.8 \text{ (} c \text{ 1.0, CH}_3\text{OH)}.$$

¹H NMR (500 MHz, CD₃OD) δ [ppm]: 7.97 (1H, s, H-7''), 4.64 (2H, s, H-5''), 4.40 (2H, t, J 7.1, H-1), 3.85-3.80 (1H, m, H-1'), 3.78 (1H, dd, J 11.6, 2.6, H_B-6'), 3.75-3.58 (8H, m, H-2', H-3', H_A-6', H_B-6, H-3'', H-4''), 3.57 (2H, t, J 6.5, H-2''), 3.40 (1H, ddd, J 8.5, 5.7, 2.6, H-5'), 3.06 (2H, t, J 6.5, H-1''), 2.32 (3H, s, SAc-CH₃), 1.95-1.86 (2H, m, H-2), 1.80-1.68 (1H, m, H_A-8), 1.55-1.40 (3H, m, H_B-8, H-3). 1.40-1.24 (8H, m, H-4-H-7).

¹³C NMR (125 MHz, CD₃OD) δ [ppm]: 197.0 (CO, SAc), 145.9 (C_q, C-6''), 124.9 (C-7''), 79.0 (CH, C-1'), 75.6 (CH, C-5'), 73.1, 72.9 (2 \times CH, C-2', C-3'), 71.2, 70.8, 70.7 (3 \times CH₂, C-2'', C-3'', C-4''), 69.3 (CH, C-4'), 65.0 (CH₂, C-5''), 63.2 (CH₂, C-6'), 51.3 (CH₂, C-1), 31.2 (CH₂, C-2), 30.5 (CH₃-SAc), 30.4, 30.3, 29.9, 29.6, 29.5, 27.4, 26.9. (6 \times CH₂, C-3-C-8, C-1'').

IR $\tilde{\nu}$ [cm⁻¹]: 3364, 2927, 2857, 1688, 1460, 1455, 1354, 1291, 1222, 1094, 958, 910, 838, 775, 668, 626.

HRMS (ESI) calculated for C₂₃H₄₂N₃O₈S [M + H]⁺: 520.2687, found 520.2690.

6.2.45 8'-((1,2,3-Triazol-4-yl)methoxyethoxyethanthioacetate)-1-C- α -D-rhamnopyranose **175**

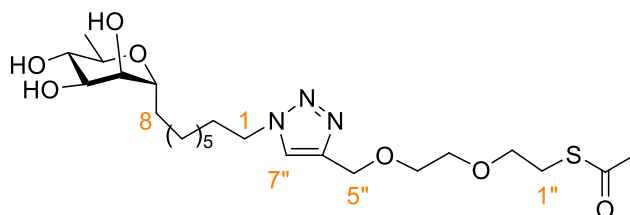

Compound **175** was prepared by adapting a published procedure.¹⁷⁵ Thus, an aqueous solution of CuSO₄ (0.2 eq, 53 mg, 0.21 mmol) and an aqueous solution of sodium ascorbate (0.8 eq, 168 mg, 0.85 mmol) in H₂O (250 μ l) were added subsequently to a yellow solution of compound **136** (1 eq, 200 mg, 0.66 mmol) and compound **171** (1.5 eq, 215 mg, 1.06 mmol) in DMF (1.7 ml). The addition of sodium ascorbate produced a brief transient colour change (red/orange) of the reaction solution indicating the presence of Cu (I). The reaction was monitored by TLC (DCM/MeOH 10:1, samples were quenched in EtOAc and H₂O before applied to TLC plate) and full conversion showed after 30 min. The reaction mixture was then concentrated in vacuum. The crude was purified by flash chromatography (DCM/MeOH 10:0.7 \rightarrow 10:1) to give a colourless syrup (313 mg, 0.62 mmol, 94%). R_f = 0.24 (DCM/MeOH 10:0.5).

$[\alpha]_D^{22} = +4.5$ (c 5.6, CH₃OH).

¹H NMR (500 MHz, CD₃OD) δ [ppm]: 7.98 (1H, s, H-7''), 4.63 (2H, s, H-5''), 4.41 (2H, t, J 7.1, H-1), 3.77 (1H, d, J 9.9, H-1'), 3.73-3.70 (1H, m, H-2'), 3.67-3.59 (5H, m, H-3', H-3'', H-4''), 3.56 (2H, t, J 6.5, H-2''), 3.47-3.36 (2H, m, 2 \times H-4', H-5'), 3.06 (2H, t, J 6.5, H-1''), 2.32 (3H, s, SAc-CH₃), 1.95-1.87 (2H, m, H-2), 1.79-1.67 (1H, m, H_A-8), 1.46-1.29 (11H, m, H_B-8, H-3-H-7), 1.24 (3H, d, J 6.0, m H-6').

¹³C NMR (125 MHz, CD₃OD) δ [ppm]: 195.5 (CO, SAc), 144.6 (C_q, C-6''), 123.6 (C-7''), 77.7 (CH, C-1'), 73.1 (CH, C-5'), 71.9 (CH, C-2'), 71.4 (CH, C-3'), 69.9 (CH₂, C-2''), 69.4, 69.3 (2 \times CH₂, C-3'', C-4''), 69.2 (CH, C-4'), 63.7 (CH₂, C-5''), 49.9 (CH₂, C-1), 29.9 (CH₂, C-2), 29.1 (CH₃-SAc), 29.0, 28.9, 28.6, 28.3, 28.2, 26.0, 25.7 (6 \times CH₂, C-3-C-8, C-1''), 17.0 (C-6').

IR $\tilde{\nu}$ [cm⁻¹]: 3388, 3150, 2927, 2856, 1688, 1452, 1355, 1291, 1222, 1176, 1087, 1057, 958, 819, 776, 723, 625, 554, 533, 480.

HRMS (ESI) calculated for C₂₃H₄₂N₃O₇S [M + H]⁺: 504.2738, found. 504.2737.

6.3 Experimentals for Individual Compounds of CM

6.3.1 8-(2',3',4'-Tri-O-benzyl-1'-deoxy- α -L-rhamnopyranos-1'yl)-oct-6-en-1-ol **126-CM**

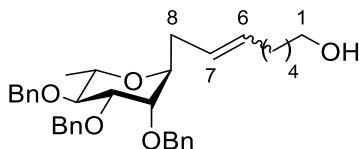

Cross-metathesis coupling **126-CM** was prepared by adapting a published procedure.¹⁷⁶ Thus, to a solution of C-glycoside **92** (1 eq, 1.0 g, 2.2 mmol) in dry DCM (10 ml), 6-hepten-1-ol **88** (0.5 eq, 125 mg, 1.1 mmol) was added, followed by addition of Grubb's 2nd generation catalyst (0.04 eq, 37 mg, 0.04 mmol). The reaction mixture was stirred at rt overnight. After TLC analysis showed complete conversion of starting material to a major product, the reaction mixture was concentrated in vacuum, and the crude was purified by flash chromatography (Hex/EtOAc 80:20 → 70:30) to give a brown syrup **126-CM** (316 mg, 0.6 mmol, 53%). R_f = 0.2 (PE/EtOAc 70:30).

¹H(400 MHz, CDCl₃) δ [ppm]: 7.43-7.21 (15H, m, H-Ph), 5.59-5.17 (2H, m, H-6, H-7), 4.93-4.81 (1H, m, H-Ph), 4.78-4.49 (5H, m, H-Ph), 3.95 (1H, td, J 7.4, J 2.8 H-1'), 3.80-3.50 (6 H, m, H-sugar, H-1), 2.34-2.10 (2 H, m, H-8), 1.97 (2H, dd, J 14.1, 6.8, H-5), 1.68-1.00 (9 H, m, H-2, H-3, H-4, H-6').

¹³C(100 MHz, CDCl₃) δ [ppm]: 138.63-138.5 (Cq-Ph), 133.3 (C-6), 128.56-127.9 (C-Ph), 125.7 (C-7), 80.6-78.5 (2 \times C-sugar), 75.0 (CH₂-Ph), 74.9-73.9 (2 \times C-sugar), 72.1-71.8 (2 \times CH₂-Ph), 69.6 (C-sugar), 63.1 (C-1), 33.2 (C-8), 32.7 (C-5), 32.6 (C-2), 29.2, 25.3 (C-4, C-3), 18.3 (C-6').

6.3.2 8-(2',3',4'-Tri-O-benzyl-1'-deoxy- α -L-rhamnopyranos-1'yl)-oct-6-en-1-(4-toluenesulfonyloxy) **128-CM**

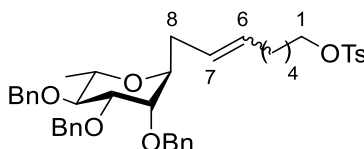

Compound **128-CM** was prepared by adapting a published procedure.¹⁵⁷ Thus, to a solution of compound **126-CM** (1 eq, 0.5 g, 0.9 mmol) in pyridine (8 ml), tosyl chloride (10 eq, 1.75 g, 9

mmol) was added at 0 °C. The reaction mixture was stirred at rt for 1 h under N₂ atmosphere. The reaction mixture was co-evaporated (3×) with toluene. The crude was then purified by flash chromatography (Hex/EtOAc 100:0 → 95:5 → 70:30) to give a colourless syrup **128-CM** (0.6 g, 0.9 mmol, 98%). *R_f* = 0.38 (PE/EtOAc 70:30).

¹H (400 MHz, CDCl₃) δ [ppm]: 7.79 (2H, d, *J* 8.0, H-OTs), 7.69-7.00 (18H, m, H-Ph), 5.32 (2H, m, H-6, H-7), 4.94-4.40 (6H, m, CH₂-Ph), 4.01 (2H, t, *J* 6.2, H-1), 3.94 (1H, dt, *J* 6.5, *J* 4.1 H-1'), 3.80-3.49 (4H, m, H-2', H-3', H-4', H-5'), 2.44 (3H, s, CH₃-OTs), 2.32-1.74 (4H, m, H_A-8, H_B-8, H-5), 1.69-1.54 (2H, m, H-2), 1.50-1.13 (7H, m, H-6', H-4, H3).

¹³C (100 MHz, CDCl₃) δ [ppm]: 138.47 (C_q-Ph), 132.7 (C-3'), 129.8-127.6 (C-Ph), 125.8 (C-2'), 80.3 (C-5), 78.2 (C-2), 74.9 (C-3), 74.8 (CH₂-Ph), 73.6 (C-1), 71.9-71.6 (2 × CH₂-Ph), 70.5 (C-8'), 69.4 (C-4), 32.9 (C-1'_A), 32.2 (C-1'_B), 31.7 (C-4'), 28.7 (C-7'), 28.1-24.8 (2 × C5', C6'), 21.6 (CH₃-OTs), 18.2-18.1 (C-6).

6.3.3 8-(1'-Deoxy-α-L-rhamnopyranos-1'yl)-oct-1-(4-toluenesulfonyloxy) **129-CM**

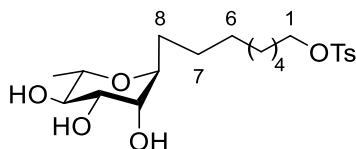

Compound **129-CM** was prepared by adapting a published procedure.¹⁵⁸ Thus, Pd(OH)₂/C (100 mg) suspended in MeOH (15 ml) was added to a stirring mixture of compound **128-CM** (1 eq, 490 mg, 0.7 mmol) in EtOAc (15 ml). The reaction mixture was set under H₂ atmosphere and stirred at rt overnight. The mixture was filtered over Celite[®], the filter pad was washed with MeOH (10 ml). The solution was concentrated under reduced pressure to give colourless oil of the title compound **129-CM** (0.3 g, 0.7 mmol, 99%). *R_f* = 0.1 (DCM/MeOH 15:1).

¹H (400 MHz, CD₃OD) δ [ppm]: 7.80 (2H, d, *J* 8.1, H-OTs), 7.46 (2H, d, *J* 8.0, OTs), 4.04 (2H, t, *J* 6.2, H-1), 3.84-3.69 (2H, m, H-sugar), 3.63 (1H, d, *J* 6.9, H-sugar), 3.51-3.36 (2H, m, H-sugar), 2.48 (3H, s, H-CH₃), 1.47 (17H, m, H-chain, H-6').

¹³C (100 MHz, CD₃OD) δ [ppm]: 146.4, 134.6 (2 × C_q), 131.0, 128.9 (2 × C-OTs), 79.1 (C-1'), 74.5, 73.3, 72.7 (3 × C-sugar), 72.0 (C-1), 70.7 (C-sugar), 30.4, 30.2, 30.1, 29.8, 29.6, 27.0, 26.3 (7 × C-chain), 21.6 (C-CH₃), 18.4 (C-6').

6.3.4 8-(1'-Deoxy- α -L-rhamnopyranos-1'yl)-oct-1-azide **130-CM**

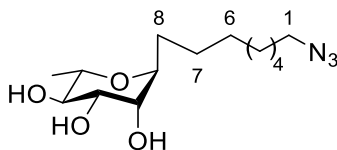

Azido compound **130-CM** was prepared by adapting a published procedure.¹⁵⁹ Thus, to a solution of compound **129-CM** (1 eq, 0.6 g, 1.4 mmol) in dry DMF (10 ml), NaN₃ (2 eq, 0.18 g, 2.8 mmol) was added. The reaction mixture was heated to 50 °C under N₂ atmosphere. Then NaI (10 eq, 2.10 g, 14 mmol) was added to the reaction mixture and left stirring for 30 min. Then the temperature was raised to 130 °C for 1.5 h. The reaction mixture was quenched with H₂O (50 ml), diluted with EtOAc (3×100 ml), washed with water (2 × 80 ml), dried and then concentrated in vacuum. The residue was purified by flash chromatography (DCM/MeOH 30:1 → 20:1) to give yellow oil **130-CM** (330 mg, 1.1 mmol, 79%). R_f = 0.2 (DCM/MeOH 15:1).

¹H NMR (400 MHz, CD₃OD) δ [ppm]: 3.78 (1H, d, *J* 9.0 H⁻¹'), 3.75-3.70 (1H, m, H-2'), 3.61 (1H, dd, *J* 8.8, 3.3, H-3'), 3.49-3.34 (2H, m, H-5', H-4'), 3.28 (2H, t, *J* 5.2, H-1), 1.85-1.70 (1H, m, H_A-8), 1.68-1.55 (2H, m, H-2), 1.55-1.30 (11H, m, 5 × CH₂, H_B-8), 1.27 (3H, d, *J* 6.0, H-6').

¹³C NMR (100 MHz, CD₃OD) δ [ppm]: 79.1 (CH, C-1'), 74.5 (CH, C-5'), 73.3 (CH, C-2'), 72.8 (CH, C-3'), 70.8 (CH, C-4'), 52.4 (C-1), 30.5-27.0 (7 × CH₂, C-2-C-8), 18.4 (CH, C-6').

6.3.5 8-(2',3',4',6'-Tetra-O-benzyl-1'-deoxy- α -D-mannopyranos-1'yl)-oct-6-en-1-ol **125-CM**

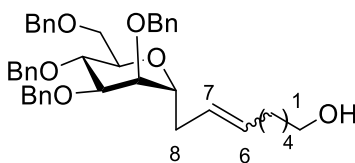

Compound **125-CM** was prepared by adapting a published procedure.¹⁷⁶ Thus, to a solution of C-glycoside **11** (1 eq, 200 mg, 0.35 mmol) in dry DCM (1.5 ml), 6-hepten-1-ol **88** (0.5 eq, 20 mg, 0.18 mmol) was added followed by addition of Grubb's 2nd generation catalyst (0.06 eq, 9 mg, 0.01 mmol). The reaction mixture was stirred at rt overnight. After completion, the reaction mixture was concentrated in vacuum and the crude was purified by flash chromatography

(Hex/EtOAc 90:10 → 80:20 → 60:40) to give a brown syrup **125-CM** (73 mg, 0.13 mmol, 73%). $R_f = 0.14$ (PE/EtOAc 70:30).

$^1\text{H NMR}$ (400 MHz, CDCl_3) δ [ppm]: 7.41-7.10 (20H, m, H-Ph), 5.47-5.22 (2H, m, H-7, H-6), 4.71 (1H, d, J 11.2, $\text{CH}_2\text{-Ph}$), 4.65-4.44 (7H, m, $\text{CH}_2\text{-Ph}$), 4.05-3.92 (1H, m, H-1'), 3.89-3.48 (8H, m, H-3', H-4', H-5', H-6', H-2', H-1), 2.37-2.10 (2H, m, H-8), 1.93 (2H, d, J 5.6, H-5), 1.57-1.42 (2H, m, H-2), 1.40-1.19 (4 H, m, H-4, H-3).

$^{13}\text{C NMR}$ (100 MHz, CDCl_3) δ [ppm]: 138.6-138.3 (Cq-Ph), 133.3 (C-6), 128.5-127.6 (C-Ph), 125.7 (C-7), 77.4-74.9 ($3 \times$ C-sugar), 74.2 ($\text{CH}_2\text{-Ph}$), 73.7 (C-sugar), 73.4 ($\text{CH}_2\text{-Ph}$), 73.1 (C-1'), 72.1-71.5 ($2 \times$ $\text{CH}_2\text{-Ph}$), 69.4 (C-6'), 63.1 (C-1), 33.4 (C-8), 32.7 (C-5), 32.6 (C-2), 29.2-25.4 (C-4, C-3).

6.3.6 8-(2',3',4',6'-Tetra-O-benzyl-1'-deoxy- α -D-mannopyranos-1'yl)-oct-6-en-1-(4-toluenesulfonyloxy) **131-CM**

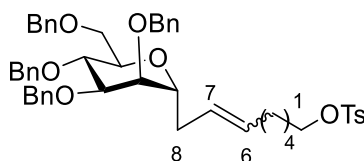

Compound **131-CM** was prepared by adapting a published procedure.¹⁵⁷ Thus, to a solution of compound **125-CM** (1 eq, 0.4 g, 0.60 mmol) in pyridine (6 ml), tosyl chloride (10 eq, 1.20 g, 6.10 mmol) at 0 °C was added to reaction mixture. The reaction mixture was then stirred at rt for 1 h under N_2 atmosphere. The reaction mixture was co-evaporated ($3 \times$) with toluene. The crude was then purified by flash chromatography (Hex/EtOAc 90:10 → 70:30) to give a colourless syrup **131-CM** (380 mg, 0.47 mmol, 77%). $R_f = 0.32$ (PE/EtOAc 70:30).

$^1\text{H NMR}$ (400 MHz, CDCl_3) δ [ppm]: 7.78 (2H, d, J 8.0, H-OTs), 7.42-7.06 (23H, m, H-Ph, H-OTs), 5.46-5.19 (2H, m, H-6, H-7), 4.85-4.43 (8H, m, $\text{CH}_2\text{-Ph}$), 4.05-3.49 (9H, m, H-sugar, H-1), 2.44 (3H, s, H- CH_3), 2.33-2.11 (2H, m, H-8), 2.03-1.79 (2H, m, H-5), 1.64-1.56 (3H, m, H-2, H-3_A), 1.43-1.14 (3H, m, H-4, H-3_B).

$^{13}\text{C NMR}$ (100 MHz, CDCl_3) δ [ppm]: 138.2 (Cq-Ph), 132.7 (C-6), 129.8-127.4 (C-Ph), 125.8 (C-7), 74.9-73.6 ($5 \times$ C-sugar), 73.2-71.4 ($\text{CH}_2\text{-Ph}$), 70.5 (C-6'), 69.2 (C-1), 33.2 (C-8), 32.2 (C-5), 31.7 (C-2), 28.6 (C-4), 24.8 (C-3), 21.6 (C- CH_3).

6.3.7 8-(1'-Deoxy- α -D-mannopyranos-1'yl)-oct-1-(4-toluenesulfonyloxy) 132-CM

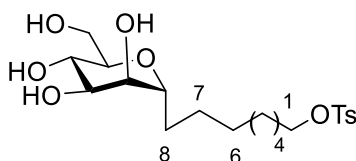

Hydrogenation of compound **131-CM** was prepared by adapting a published procedure.¹⁵⁸ Thus, Pd(OH)₂/C (400 mg) suspended in MeOH (25 ml) was added to a stirred mixture of compound **131-CM** (1 eq, 1.9 g, 2.4 mmol) in EtOAc (25 ml) under H₂ atmosphere at rt. The reaction was stirred overnight. The mixture was filtered over Celite[®], and the filter pad was washed with MeOH (20 ml). The solution was concentrated under reduced pressure to give colourless oil of the title compound **132-CM** (0.8 g, 1.8 mmol, 77%). R_f = 0.1 (DCM/MeOH 15:1).

¹H NMR (400 MHz, CD₃OD) δ [ppm]: 7.78 (2 H, d, *J* 8.3, H-OTs), 7.44 (2H, d, *J* 8.1, H-OTs), 4.02 (2H, t, *J* 6.3, H-1), 3.87-3.57 (6H, m, H-sugar), 3.39 (1H, ddd, *J* 16.5, 9.4, 6.6, H-5'), 2.46 (3H, s, CH₃-OTs), 1.81-1.14 (14 H, m, H-chain).

¹³C NMR (100 MHz, CD₃OD) δ [ppm]: 134.6 (C_q-OTs), 131.0 -128.9 (C-OTs), 79.0 (C-1'), 75.6 (C-5'), 73.1, 72.9 (2 × C-sugar), 72.0 (C-1), 69.3 (C-sugar), 63.1 (C-6'), 30.4, 30.2, 29.8, 29.6, 26.9, 26.8, 26.4 (7 × C-chain), 21.6 (C-CH₃).

6.3.8 8-(1'-Deoxy- α -D-mannopyranos-1'yl)-oct-1-azide 133-CM

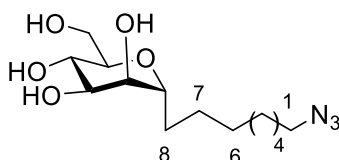

Azido compound **133-CM** was prepared by adapting a published procedure.¹⁵⁹ Thus, to a solution of compound **132-CM** (1 eq, 0.7 g, 1.65 mmol) in dry DMF (12 ml), NaN₃ (2 eq, 216 mg, 3.3 mmol) was added. The reaction mixture was heated to reach 50 °C under N₂ atmosphere, then the temperature was raised to 130 °C and kept stirring at that temperature for 1.5 h. The reaction mixture was quenched with H₂O (70 ml), diluted with EtOAc (3×120 ml), washed with water (2 × 100 ml). The organic phase was concentrated under vacuum and the residue

purified by flash chromatography (DCM/MeOH 15:1) to give yellow oil **133-CM** (4.4 g, 1.4 mmol, 85%). $R_f = 0.2$ (DCM/MeOH 10:1).

^1H NMR (400 MHz, CD_3OD) δ [ppm]: 3.86-3.80 (1H, m, H-1'), 3.78 (1H, dd, J 11.6, 2.7, H_A-6'), 3.75-3.58 (4H, m, H-2', H-3', H-4', H_B-6'), 3.40 (1H, ddd, J 8.4, 5.7, 2.7, H-5'), 3.27 (2H, t, J 6.8, H-1) 1.74-1.69 (1H, m, H_A-8), 1.64-1.53 (2H, m, H-2), 1.52-1.25 (11H, m, H_B-8, H-3-H-7).

^{13}C NMR (100 MHz, CD_3OD) δ [ppm]: 79.0 (C-1'), 75.6 (C-5'), 73.1, 72.9, 69.3 (3 \times CH- C-2', C-3', C-4'), 63.2 (CH₂, C-6'), 52.4 (CH₂, C-1), 30.5, 30.4, 30.2, 29.9, 29.6, 27.8, 26.9 (7 \times CH₂-chain).

6.3.9 8-(2',3',4'-Tri-O-benzyl-1'-deoxy- α -D-rhamnopyranos-1'yl)-oct-6-en-1-ol **127-CM**

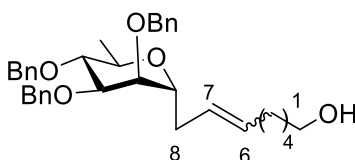

The coupling reaction **127-CM** was prepared by adapting a published procedure.¹⁷⁶ Thus, to solution of C-glycoside **103** (1 eq, 1 g, 2.2 mmol) in dry DCM (10 ml), 6-hepten-1-ol **88** (0.5 eq, 0.13 g, 1.1 mmol) was added followed by addition of Grubb's 2nd generation catalyst (0.04 eq, 40 mg, 0.05 mmol). The reaction mixture was stirred at rt overnight. After TLC analysis showed complete conversion of starting material to a major product, the reaction mixture was concentrated in vacuum and the crude was purified by flash chromatography (Hex/EtOAc 80:20 \rightarrow 70:30) to give a brown syrup **127-CM** (0.32 g, 0.6 mmol, 54%). $R_f = 0.2$ (PE/EtOAc 70:30).

^1H NMR (400 MHz, CDCl_3) δ [ppm]: 7.53-7.16 (15H, m, H-Ph), 5.64-5.16 (2H, m, H-7, H-6), 4.97-4.49 (6H, m, H-Ph), 3.97 (1H, td, J 7.5, 2.9, H-1'), 3.82-3.50 (6H, m, H-2', H-3', H-4', H-5', H-1), 2.23 (2H, m, H-8), 1.99 (2H, m, H-5), 1.62-1.23 (9H, m, H-2, H-3, H-4, H-6').

^{13}C NMR (100 MHz, CDCl_3) δ [ppm]: 138.4-138.3 (C_q-Ph), 133.1 (C-6), 128.3-127.6 (C-Ph), 125.5 (C-7), 80.4, 78.3, 76.43 (3 \times C-sugar), 74.8 (CH₂-Ph), 73.7 (C-sugar), 71.9, 71.6 (2 \times CH₂-Ph), 69.4 (C-sugar), 62.8 (C-1), 32.9 (C-8), 32.5 (C-5), 32.4 (C-2), 29.1, 25.2 (C-4, C-3), 18.2 (C-6').

6.3.10 8-(2',3',4'-Tri-O-benzyl-1'-deoxy- α -D-rhamnopyranos-1'yl)-oct-6-en-1-(4-toluenesulfonyloxy) **134-CM**

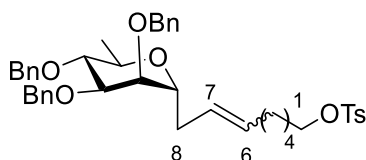

Compound **134-CM** was prepared by adapting a published procedure.¹⁵⁷ Thus, to a solution of compound **127-CM** (1 eq, 340 mg, 0.62 mmol) in pyridine (10 ml), tosyl chloride (10 eq, 1.2 g, 6.2 mmol) was added to reaction mixture at 0 °C. The reaction mixture was then stirred at rt for 1 h under N₂ atmosphere. After TLC analysis showed complete conversion of starting material to a major product, the reaction mixture was co-evaporated (3×) with toluene. The crude was purified by flash chromatography (PE/EtOAc 95:5 → 80:20) to give a colourless syrup **134-CM** (0.39 g, 0.55 mmol, 90%). *R_f* = 0.38 (PE/EtOAc 70:30).

¹H NMR (400 MHz, CDCl₃) δ [ppm]: 7.79 (2H, d, *J* 8.1, H-OTs), 7.50-7.17 (17H, m, H-Ph), 5.55-5.15 (2H, m, H-7, H-6), 4.92-4.80 (1H, m, CH₂-Ph), 4.76-4.50 (5H, m, CH₂-Ph), 4.08-3.86 (3H, m, H-1, H-1'), 3.78-3.49 (4H, m, H-sugar), 2.44 (2H, s, CH₃-OTs), 2.33-2.06 (2H, m, H-8), 2.01-1.81 (2H, m, H-5), 1.70-1.51 (2H, m, H-2), 1.41-1.15 (7H, m, H-4, H-3, H-6').

¹³C NMR (100 MHz, CDCl₃) δ [ppm]: 138.5-138.3, 132.7 (C-6), 129.8-127.6 (C-Ph), 125.8 (C-7), 80.3, 78.2, 74.9 (3 × C-sugar), 74.8 (CH₂-Ph), 73.6 (C-1'), 71.9, 71.6 (2 × CH₂-Ph), 70.5 (C-1), 69.5 (C-sugar), 32.9 (C-8), 32.2 (C-5), 28.7 (C-2), 28.2, 24.8 (2 × C-4, C-3), 21.6 (CH₃-OTs), 18.2 (C-6').

6.3.11 8-(1'-Deoxy- α -D-rhamnopyranos-1'yl)-oct-1-(4-toluenesulfonyloxy) **135-CM**

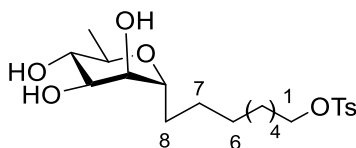

Compound **135-CM** was prepared by adapting a published procedure.¹⁵⁸ Thus, Pd(OH)₂/C (150 mg) suspended in MeOH (25 ml) was added to stirring mixture of compound **134-CM** (1 eq, 2.0 g, 2.9 mmol) in EtOAc (25 ml). The reaction mixture was stirred overnight under H₂

atmosphere at rt. After TLC analysis showed complete conversion of starting material to a major product, the reaction mixture was filtered using Celite[®]. The filter material was washed with MeOH (20ml), and the solution concentrated under reduced pressure to give a colourless oil **135-CM** (1.1 g, 2.6 mmol, 90%). $R_f = 0.36$ (DCM/MeOH 10:1).

¹H NMR (400 MHz, CD₃OD) δ [ppm]: 7.80 (2 H, d, J 8.1, H-OTs), 7.46 (2H, d, J 8.0, OTs), 4.04 (2H, t, J 6.2, H-1), 3.84-3.69 (2H, m, H-sugar), 3.63 (1H, d, J 6.9, H-sugar), 3.51-3.36 (2H, m, H-sugar), 2.48 (3H, s, H-CH₃), 1.47 (17H, m, H-chain, H-6').

¹³C NMR (100 MHz, CD₃OD) δ [ppm]: 146.4, 134.6 (2 \times Cq), 131.0, 128.9 (2 \times C-OTs), 79.1 (C-1), 74.5, 73.3, 72.7 (3 \times C-sugar), 72.0 (C-1), 70.7 (C-sugar), 30.4, 30.2, 30.1, 29.8, 29.1, 27.0, 26.3 (7 \times C-chain), 21.6 (C-CH₃), 18.4 (C-6').

6.3.12 8-(1'-deoxy- α -D-rhamnopyranos-1'yl)-oct-1-azide **136-CM**

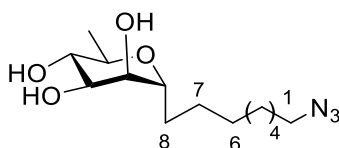

Azido compound **136-CM** was prepared by adapting a published procedure.¹⁵⁹ Thus, to a solution of compound **135-CM** (1 eq, 1.2 g, 2.7 mmol) in dry DMF (30 ml), NaN₃ (2 eq, 0.4 g, 5.4 mmol) was added. The reaction mixture was heated to 50 °C under N₂ atmosphere, then the temperature was raised to 130 °C for 1.5 h. After the reaction mixture had been allowed to cool down to rt, it was taken between H₂O (50 ml) and EtOAc (250 ml). The organic phase was then washed with water (100 ml) and then concentrated in vacuum. The residue was purified by flash chromatography (DCM/MeOH 30:1 \rightarrow 20:1) to give yellow oil **136-CM** (480 mg, 1.6 mmol, 57 %). $R_f = 0.34$ (DCM/MeOH 10:1).

¹H NMR (400 MHz, CD₃OD) δ [ppm]: 3.78 (1H, d, J 8.9, H-1'), 3.75-3.70 (1H, m, H-2'), 3.61 (1H, dd, J 8.7, 3.3, H-3'), 3.49-3.34 (2H, m, H-4', H-5'), 3.28 (2H, t, J 6.8, H-1), 1.82-1.68 (1H, m, H_A-8), 1.64-1.52 (2H, m, H-2), 1.50-1.28 (11H, m, 5 \times CH₂, H_B-8), 1.25 (3H, d, J 6.0, H-6').

¹³C NMR (100 MHz, CD₃OD) δ [ppm]: 77.7 (CH, C-1'), 73.1 (CH, C-5'), 71.9 (CH, C-2'), 71.4 (CH, C-3'), 69.3 (CH₂, C-4'), 51.1 (CH₂, C-1), 29.1 (CH₂, C-8), 29.0 (CH₂, C-2), 28.8, 28.5, 28.2, 26.4, 25.7, (5 \times CH₂, C-3-C-7), 17.0 (CH, C-6').

6.4 Synthesis of The Bifunctional Spacer

6.4.1 2-(2-(4-Toluenesulfonyloxy ethoxy)ethan-1-ol) **149**¹⁷⁷

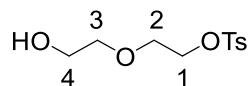

Compound **149** was prepared by following a published procedure. Thus, to a solution of diethyleneglycol **148** (1 eq, 150.0 g, 1410 mmol) in CH_2Cl_2 (400 ml) under N_2 atmosphere, triethylamine (0.15 eq, 21.4 g, 212 mmol) was added. The solution was cooled at 0 °C then tosyl chloride (0.1 eq, 26.8 g, 141 mmol) was added to reaction mixture. The reaction mixture was stirred at rt overnight. After TLC analysis showed complete conversion of starting material to a major product, the reaction mixture was extracted with DCM and H_2O (200 ml). The organic phase was washed with H_2O (2×200 ml), then washed with AcOH (2%) and H_2O (2×200 ml). After drying and concentration the crude was then purified by flash chromatography (PE/EtOAc 50:50) to give a colourless oil **149** (28.5 g, 109.50 mmol, 78%). $R_f = 0.17$ (PE/EtOAc 50:50).

^1H NMR (400 MHz, CDCl_3) δ [ppm]: 7.78 (2H, d, J 8.3, H-Ph), 7.33 (2H, d, J 8.1, H-Ph), 4.20-4.14 (2H, m, H-1), 3.70-3.60 (4H, m, H-2, H-3), 3.53-3.47 (2H, m, H-4), 2.42 (3H, s, H- CH_3).

^{13}C NMR (100 MHz, CDCl_3) δ [ppm]: 144.99 (Cq-OTs), 132.94 (Cq-OTs), 129.87 (H-Ph), 127.93 (H-Ph), 72.50 (C-4), 69.22 (C-1), 68.55 (C-2), 61.60 (C-3), 21.63 (C- CH_3). The NMR data was in accordance with the published data.

IR $\tilde{\nu}$ [cm^{-1}]: 3421, 2874, 1663, 1597, 1494, 1399, 1350, 1307, 1291, 1245, 1211, 1188, 1172, 1132, 1095, 1067, 1009, 916, 814, 772, 705, 689, 661, 580, 552, 500, 466.

6.4.2 2-(2-Azido ethoxy)ethan-1-ol **150**¹⁷⁷

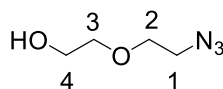

Compound **150** was prepared by following a published procedure. Thus, to a solution of compound **149** (1 eq, 26.4 g, 101.40 mmol) in dry DMF (200 ml) under N_2 atmosphere, sodium azide (2 eq, 13.13 g, 202 mmol) was added. The reaction mixture was stirred at 130 °C. TLC analysis showed complete conversion of starting material after 2 h. The reaction mixture was

cooled to rt then quenched with H₂O and extracted with EtOAc (500 ml). The organic phase was washed with H₂O (2 × 200 ml) and then dried and concentrated in vacuum. The crude was purified by flash chromatography (PE/EtOAc 70:30) to give a colourless oil **150** (12.0 g, 91.50 mmol, 90%). *R_f* = 0.29 (PE/EtOAc 70:30).

¹H NMR (400 MHz, CDCl₃) δ [ppm]: 3.78-3.73 (2H, m, H-4), 3.71-3.68 (2H, m, H-2), 3.63-3.59 (2H, m, H-3), 3.41 (2H, t, *J* 4.9, H-1).

¹³C NMR (100 MHz, CDCl₃) δ [ppm]: 72.54 (C-2), 70.23 (C-3), 61.93 (C-4), 50.85 (C-1). The NMR data was in accordance with the published data.

IR $\tilde{\nu}$ [cm⁻¹]: 3394, 2928, 2870, 2093, 1638, 1442, 1345, 1283, 1123, 1061, 921, 887, 847, 814, 642, 555, 504.

6.4.3 3-(2-(2-Azidoethoxy)ethoxy)prop-1-yne **151**¹¹³

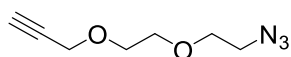

The alkyne compound **151** was prepared by following a published procedure. Thus, to cooled solution of NaH (2 eq, 4.4 g, 183 mmol) in DMF (120 ml) at 0 °C, azido compound **150** (1 eq, 12.0 g, 91.5 mmol) was slowly added. 80% propargyl bromide in toluene (1.2 eq, 12.3 ml, 110 mmol) was slowly added to the mixture solution. The reaction was then allowed to stir at rt for 2h, then the reaction was quenched with H₂O and extracted with EtOAc (2 × 200 ml), then was washed with H₂O (2 × 100 ml) then dried and concentrated. The crude was then purified by flash chromatography (PE/EtOAc 90:10) to give a yellow oil **151** (12.1 g, 71.87 mmol, 78%). *R_f* = 0.33 (PE/EtOAc 90:10).

¹H NMR (400 MHz, CDCl₃) δ [ppm]: 4.20 (2H, d, *J* 2.2, CH₂-Cq), 3.72-3.64 (6 H, m, -CH₂O), 3.39 (2H, t, *J* 5.0, CH₂-N), 2.43 (1H, t, *J* 2.2, CH).

¹³C NMR (100 MHz, CDCl₃) δ [ppm]: 79.6 (Cq), 74.7 (CH), 70.6, 70.1, 69.2 (3 × -CH₂O), 58.6 (CH₂-Cq), 50.8 (C-N). The NMR data was in accordance with the published data.

IR $\tilde{\nu}$ [cm⁻¹]: 3251, 3142, 2930, 2868, 2101, 1635, 1458, 1351, 1286, 1236, 1199, 1092, 1048, 974, 922, 884, 838, 772, 645, 555, 503.

6.4.4 2-(2-Prop-2-ynoxy)ethoxy)ethan-1-ol **153**¹⁷⁸

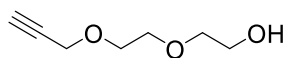

Compound **153** was prepared by following a published procedure. Thus, to a solution of diethyleneglycol **148** (1 eq, 75.0 g, 706 mmol) in dry THF (200 ml) under N₂ atmosphere, NaH (0.53 eq, 9.0 g, 375 mmol) was added portionwise. The reaction mixture was stirred at r.t. for 20 min. 80% propargyl bromide in toluene (0.33 eq, 26 ml, 233 mmol) was slowly added to the mixture solution, and then the reaction was monitored by TLC. for 1 h. The reaction was then quenched with H₂O and extracted with EtOAc (2 × 300 ml), then was washed with H₂O (2 × 200 ml). The organic phase was dried and concentrated under vacuum. The crude was then purified by flash chromatography (PE/EtOAc 1:2) to give a yellow oil **153** (26.0 g, 180 mmol, 77%). R_f = 0.33 (PE/EtOAc 1:2).

¹H NMR (400 MHz, CDCl₃) δ [ppm]: 4.11 (2H, d, *J* 2.3, CH₂-Cq), 3.68-3.57 (6H, m, 3 × O-CH₂), 3.50 (2H, t, *J* 3.5, CH₂-OH), 2.44-2.38 (1H, m, CH).

¹³C NMR (100 MHz, CDCl₃) δ [ppm]: 79.4 (Cq), 74.8 (CH), 72.5, 70.0, 68.9, 61.5 (4 × CH₂), 58.3 (CH₂-Cq). The NMR data was in accordance with the published data.

IR $\tilde{\nu}$ [cm⁻¹]: 3421, 3282, 2935, 2870, 1457, 1450, 1350, 1335, 1246, 1131, 1127, 1093, 1064, 1031, 920, 887, 838, 650, 644, 509, 499.

6.4.5 3-(2-4-Toluenesulfonyloxy ethoxy)prop-1-yne **154**¹⁷⁹

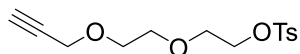

Compound **154** was prepared by following a published procedure. Thus, a solution of compound **153** (1 eq, 12.6 g, 87 mmol) in pyridine (100 ml) under N₂ atmosphere, tosyl chloride (1.5 eq, 25.0 g, 131 mmol) was added to reaction mixture at 0°C. The reaction was then allowed to stir at rt for overnight. The reaction mixture was co-evaporated (3 ×) with toluene. The crude was then purified by flash chromatography (PE/EtOAc 90:10) to give yellow syrup of **154** (14.0 g, 47 mmol, 54%). R_f = 0.6 (PE/EtOAc 2:1).

^1H NMR (400 MHz, CDCl_3) δ [ppm]: 7.80 (2H, d, J 8.2, H-Ph), 7.34 (2H, d, J 8.2, H-Ph), 4.20-4.12 (4H, m, O- CH_2 -C, CH_2 -OTs), 3.72 (2H, t, J 9.6, O- CH_2 - CH_2 -OTs), 3.66-3.57 (4H, m, $2 \times$ O- CH_2), 2.44 (3H, s, CH_3 -OTs), 2.43 (1H, t, J 2.3, CH).

^{13}C NMR (100 MHz, CDCl_3) δ [ppm]: 144.9, 133.1 ($2 \times$ Cq), 129.9, 128.1 ($2 \times$ C-Ph), 79.6 (Cq), 74.8 (CH), 70.7, 69.3 ($2 \times$ O- CH_2), 69.1 (CH_2 -TOs), 68.8 (O- CH_2 - CH_2 -TOs), 58.6 (CH $_2$ -Cq), 21.8 (CH_3 -TOs). The NMR data was in accordance with the published data.

IR $\tilde{\nu}$ [cm^{-1}]: 3281, 2960, 2945, 2871, 1597, 1495, 1450, 1399, 1350, 1292, 1246, 1211, 1188, 1174, 1137, 1094, 1011, 915, 815, 773, 661, 581, 552, 466.

6.4.6 3-(2-Phthalimideoxyethoxy)prop-1-yne **155**

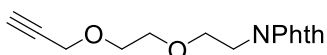

Compound **155** was prepared by adapting a published procedure.¹⁸⁰ Thus, to a solution of compound **154** (1 eq, 7.0 g, 23.46 mmol) in dry DMF (200 ml) under N_2 atmosphere, potassium phthalimide (1.1 eq, 4.78 g, 25.80 mmol) was added. The solution was heated at $100\text{ }^\circ\text{C}$ for overnight, and then the mixture was cooled to r.t., then the reaction was diluted with H_2O (100 ml) and extracted with EtOAc (2×200 ml), then dried and concentrated in vacuum. The crude was then purified by flash chromatography (PE/EtOAc 80:20) to give a white solid of **155** (6.0 g, 22 mmol, 93%). $R_f = 0.11$ (PE/EtOAc 80:20).

^1H NMR (400 MHz, CDCl_3) δ [ppm]: 7.83 (2H, dt, J 6.9, 2.4, H-Ph), 7.70 (H, dd, J 5.2, 3.1, H-Ph), 4.14-4.09 (2 H, m, O- CH_2 -C), 3.90 (H, t, J 5.8, CH_2 -N), 3.74 (2H, t, J 5.8, N- CH_2 - CH_2), 3.65 (4H, m, $2 \times$ O- CH_2), 2.37 (1H, t, J 2.0, CH).

^{13}C NMR (100 MHz, CDCl_3) δ [ppm]: 168.4 (C=O), 134.0 (C-Ph), 123.4 (C-Ph), 79.7 (Cq), 74.6 (CH), 69.9, 69.2 ($2 \times$ O- CH_2), 68.1 (CH_2 - CH_2 -N), 58.5 (CH_2 -Cq), 37.3 (CH_2 - CH_2 -N).

IR $\tilde{\nu}$ [cm^{-1}]: 3271, 3068, 2937, 2912, 2886, 2862, 1764, 1702, 1615, 1483, 1469, 1455, 1422, 1395, 1374, 1325, 1265, 1240, 1192, 1129, 1088, 1028, 987, 918, 835, 716, 655, 514.

6.4.7 2-(2-(Prop-2-ynoxy)ethoxy)ethanamine **152**

6.4.7.1 Alternative 1¹¹³

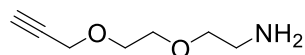

The amine compound **152** was prepared by following a published procedure. Thus, compound of **151** (1eq, 470 mg, 2.77 mmol) was dissolved in THF (4 ml). PPh₃ (1.2 eq, 880 mg, 3.36 mmol) and H₂O (0.1 ml) were added to the solution. The reaction was then allowed to stir at rt for overnight. The reaction mixture was concentrated under pressure and the residue then purified by silica gel chromatography (DCM/MeOH 1:1) to give a yellow colour **152** (250 mg, 1.74 mmol, 63%). R_f = 0.23 (DCM/MeOH 1:1).

¹H NMR (400 MHz, CDCl₃) δ [ppm]: 4.21 (2H, d, *J* 2.3, CH₂-Cq), 3.68 (4H, ddd, *J* 8.8, 6.1, 3.3, O-CH₂), 3.51 (2H, t, *J* 5.2, CH₂-CH₂-N), 2.87 (2H, t, *J* 5.2, CH₂-N), 2.43 (1H, t, *J* 2.3, CH).

¹³C NMR (100 MHz, CDCl₃) δ [ppm]: 79.6 (Cq), 74.6 (CH), 73.6 (O-CH₂-CH₂-N), 70.1, 69.1 (O-CH₂-CH₂-O), 58.4 (CH₂-Cq), 41.8 (CH₂-N). The NMR data was in accordance with the published data.

6.4.7.2 Alternative 2¹⁸¹

Compound **152** was prepared by adapting a published procedure.¹¹⁵ Thus, hydrazine hydrate (10 eq, 2.85 ml, 91.47 mmol) was added to compound **155** (1 eq, 2.5 g, 9.14 mmol) dissolved in (50 ml) of DCM. The solution was monitored by TLC and stirred for overnight. The compound **152** was possible decanted from side product to obtain (1.2 g, 8.38 mmol, 91%) without further purification.

¹H NMR (400 MHz, CDCl₃) δ [ppm]: 4.21 (2H, d, *J* 2.3, CH₂-Cq), 3.68 (4H, ddd, *J* 8.8, 6.1, 3.3, O-CH₂), 3.51 (2H, t, *J* 5.2, CH₂-CH₂-N), 2.87 (2H, t, *J* 5.2, CH₂-N), 2.43 (1H, t, *J* 2.3, CH).

¹³C NMR (100 MHz, CDCl₃) δ [ppm]: 79.6 (Cq), 74.6 (CH), 73.6 (CH₂-CH₂-N), 70.1, 69.1 (O-CH₂-CH₂-O), 58.4 (CH₂-Cq), 41.8 (CH₂-N).

IR $\tilde{\nu}$ [cm⁻¹]: 3370, 3248, 2905, 2869, 1655, 1567, 1474, 1460, 1367, 1351, 1307, 1100, 1090, 1036, 921, 882, 819, 775, 636, 588, 5535, 501.

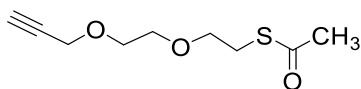
6.4.8 2-(2-(Prop-2-ynoxy)ethoxy)ethan thioacetate **171**

Procedure A: Compound **171** was prepared by adapting a published procedure^{135,136} Thus, a solution of compound **154** (1 eq, 0.5 g, 1.67 mmol) in DMF (3 ml) was added drop wise to a solution of thioacetic acid (1 eq, 0.12 ml, 1.67 mmol) in DMF (2 ml) at rt. Three drops of Et₃N were added under N₂ atmosphere, and the reaction was stirred overnight. The reaction was quenched with H₂O, extracted with EtOAc (50 ml), and then was washed with H₂O (2 × 30 ml). The organic phase was dried and concentrated in vacuum. The crude was then purified by silica gel chromatography column (PE/EtOAc 90:10 → 80:20) to give a pale yellow oil of **171** (285 mg, 1.4 mmol, 84%). *R_f* = 0.26 (PE/EtOAc 90:10).

¹H NMR (400 MHz, CDCl₃) δ [ppm]: 4.21 (2H, d, *J* 2.3, CH₂-Cq), 3.72-3.64 (4H, m, O-CH₂), 3.61 (2H, t, *J* 6.5, CH₂-CH₂-S), 3.10 (2H, t, *J* 6.5, CH₂-S), 2.46 (1H, t, *J* 2.3, CH), 2.34 (s, 3H, -CH₃).

¹³C NMR (100 MHz, CDCl₃) δ [ppm]: 195.5 (-CO), 79.6 (Cq), 74.6 (-CH), 70.1, 69.8, 68.9 (3 × -O-CH₂), 58.4 (CH₂-Cq), 30.6 (-CH₃), 28.8 (-CH₂-S).

IR $\tilde{\nu}$ [cm⁻¹]: 3277, 2950, 2866, 1686, 1441, 1353, 1290, 1245, 1094, 1045, 953, 919, 841, 682, 624, 530.

HRMS (ESI) calculated for C₉H₁₅O₃S [M + H]⁺: 203.0736, found 203.0736.

Procedure B: A solution of compound **154** (1 eq, 1.0 g, 3.35 mmol) in DMF (3 ml) was added drop wise to a mixture of potassium thioacetate (1 eq, 383 mg, 3.35 mmol) in DMF (3 ml). The reaction mixture was stirred under N₂ atmosphere, and continued at r.t. overnight. The crude was then purified by flash chromatography (PE/EtOAc 90:10) to give a yellow oil of **171** (610 mg, 3 mmol, 90%). The NMR data was as reported for alternative **A**.

CHAPTER 7

Appendices

Red text is used to make it easier for the reader to see the differences to previously presented experimentals.

7.1 Attempted Failed Coupling Reactions of Alginate With The Amino-Linker

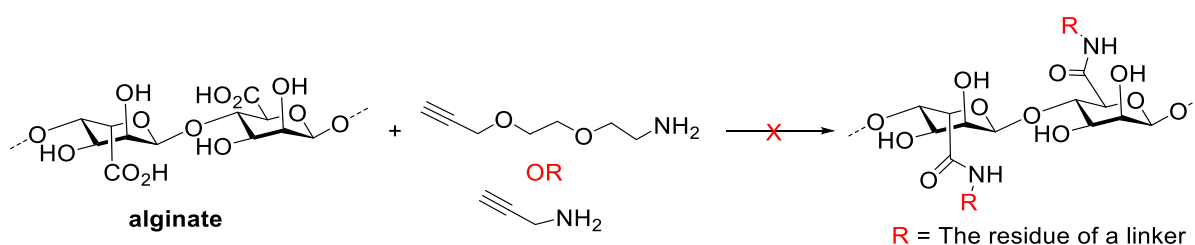

7.1.1 Attempt to Synthesise Scaffold of Alginate With 2-(2-(Prop-2-ynyloxy)ethoxy)ethanamine

In a small beaker (25 mL) alginate (50.0 mg, 0.23 mmol) was dissolved with H₂O (10 ml) in pH ~ 4. 1-Ethyl-3-(3-dimethylaminopropyl)carbodiimide (50.0 mg, 0.26 mmol) and N-hydroxysuccinimide (25.0 mg, 0.22 mmol) were added to the solution of alginate. 2-(2-(Prop-2-ynyloxy)ethoxy)ethanamine (50.0 mg, 0.35 mmol) was added to the mixture after dissolving in 100 μ l in H₂O. The reaction mixture was stirred overnight at room temperature. Purification was by three days of dialysis (12-14 KDa MWCO) against 400 ml of water, which was changed two times a day. The alginate solution was dried using freeze drying machine for 2-3 days.

This reaction was tested many times with different ratio of peptide coupling reagents.

7.1.2 Attempt to Synthesise Scaffold of Alginate With Propargyl Amine

In a small beaker (25 mL) alginate (100.0 mg, 0.46 mmol) was dissolved with H₂O (20 ml) in pH ~ 4. 1-Ethyl-3-(3-dimethylaminopropyl)carbodiimide (98.0 mg, 0.5 mmol) and N-hydroxy-succinimide (47.0 mg, 0.44 mmol) were added to the solution of alginate. The propargyl amine (38.0 mg, 0.69 mmol) was added to the mixture after dissolving in 50 µl in H₂O. The reaction mixture was stirred overnight at room temperature. Purification was by three days of dialysis (12-14 KDa MWCO) against 400 ml of water, which was changed two times a day. The alginate solution was dried using freeze drying machine for 2-3 days. **This reaction was tested twice.**

7.2. Attempt to Synthesise of Thio-Linker With Amide Bond

7.2.1 Testing The Dithiodiglycolic Acid With Benzyl Amine

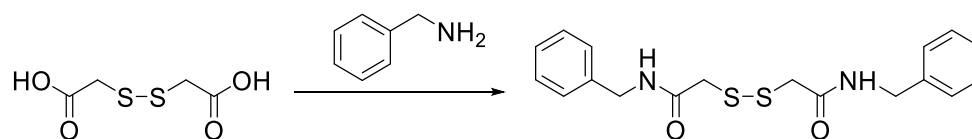

Dithiodiglycolic acid (50.0 mg, 0.27 mmol) was dissolved in DMF (1 ml), Carbonyldiimidazole (CDI) (130.0 mg, 0.81 mmol) was added and the reaction mixture stirred at r.t for 30 min. After this time, white precipitate was formed. To this, benzyl amine (70 µl, 0.6 mmol) was added. The reaction mixture was stirred overnight at room temperature. The mixture was filtered over Celite[®]. The solution was concentrated under reduced pressure and the residue was purified by flash chromatography (DCM/MeOH 20:1) giving yield of 11% (11 mg, 0.03 mmol). **This reaction was tried with THF and gave 14% as a yield (14 mg, 0.04 mmol).**

7.2.3 Testing The Dithiodiglycolic Acid With Benzyl Amine

Dithiodiglycolic acid (50.0 mg, 0.27 mmol) was dissolved in H₂O (1 ml), benzyl amine (70 µl, 0.6 mmol) and DMAP (67.0 mg, 0.6 mmol) were added. The reaction mixture was stirred at r.t for 30 min. After this time, EDC (105.0 mg, 0.54 mmol) was added to this mixture. The reaction mixture was stirred overnight at room temperature then filtered over Celite[®]. TLC did not show any spot for product.

7.2.4 Testing The Dithiodiglycolic Acid With Benzyl Amine

Dithiodiglycolic acid (50.0 mg, 0.27 mmol) was dissolved in **pyridine** (1 ml), benzyl amine (70 μ l, 0.6 mmol) was added. The reaction mixture was stirred at r.t. for 30 min. After this time, **EDC** (105.0 mg, 0.54 mmol) was added to this mixture. The reaction mixture was stirred overnight at room temperature then filtered over Celite[®]. TLC did not show any spot for product.

7.2.5 Testing The Dithiodiglycolic Acid With Benzyl Amine

Dithiodiglycolic acid (50.0 mg, 0.27 mmol) was dissolved in **DMF** (1 ml), **HOBt** (250.0 mg, 1.63 mmol) and **DCC** (335 mg, 1.62 mmol) were added. This mixture was added slowly into the solution of benzyl amine (70 μ l, 0.65 mmol) in DMF (100 μ l). The reaction mixture was stirred overnight at room temperature. TLC did not show any spot for product.

7.2.6 Testing The Dithiodiglycolic Acid With Benzyl Amine

Dithiodiglycolic acid (50.0 mg, 0.27 mmol) was dissolved in **pyridine** (1 ml), **HOBt** (60.0 mg, 0.38 mmol) and **EDC** (115.0 mg, 0.6 mmol) were added and stirred for 15 min. Benzyl amine (70 μ l, 0.65 mmol) in pyridine (100 μ l) was added dropwise to the acid mixture. The reaction mixture was stirred overnight at room temperature, TLC showed a light spot of product.

7.2.7 Testing The Dithiodiglycolic Acid With Benzyl Amine

Dithiodiglycolic acid (50.0 mg, 0.27 mmol) was dissolved in **H₂O** (3 ml), **NHS** (160.0 mg, 1.4 mmol) and benzyl amine (70 μ l, 0.65 mmol) were added and stirred for 15 min. **EDC** (115.0 mg, 0.6 mmol) was then added to the reaction mixture. The reaction mixture was stirred overnight at room temperature, TLC did not show any spot.

7.2.8 Testing The Dithiodiglycolic Acid With Benzyl Amine

Dithiodiglycolic acid (50.0 mg, 0.27 mmol) was dissolved in **DMF** (1 ml), **NHS** (62.0 mg, 0.5 mmol) and **EDC** (115.0 mg, 0.6 mmol) were added and stirred for 15 min. Benzyl amine (90 μ l, 0.8 mmol) was then added slowly to the reaction mixture. The reaction mixture was stirred overnight at room temperature under N₂ atmosphere. After two days, TLC showed a light spot.

An additional portion of EDC and NHS with the same amount was added to the reaction mixture. TLC did not show any progression.

7.2.9 Testing The Dithiodiglycolic Acid With Benzyl Amine

Dithiodiglycolic acid (50.0 mg, 0.27 mmol) and SOCl_2 (70 μl , 1 mmol) dissolved in DCM/DMF (10:1 ml), the mixture was refluxed for 3h then concentrated under reduced pressure. The residue was then dissolved in DCM (5 ml). Benzyl amine (0.5 ml, 4.75 mmol) was then added dropwise at 0 °C. The reaction mixture was stirred overnight at room temperature under N_2 atmosphere. TLC showed a spot of product in (DCM/MeOH 30:1). The was quenched with water (2 ml) and then stirred for 30 min. White precipitate was formed and then filtered. This precipitation was washed with $\text{H}_2\text{O}/\text{EtOH}$ (3:1) and then purified by recrystallization from Acetone/Hexane to give the product (50.0 mg, 0.14 mmol, 50%).

^1H NMR (400 MHz, DMSO) δ [ppm]: 7.36-7.19 (m, 3H), 4.30 (d, J 5.9, 2H), 3.55 (s, 2H).

7.3 Attempted The Coupling of Dithiodiglycolic Acid With Acetylated of 8-(1'-Deoxy- α -L-rhamnopyranos-1'yl)-oct-1-amine

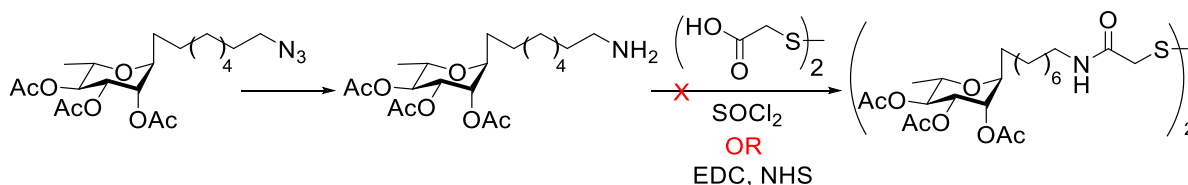

Hydrogenation of L-rhamnoside was achieved by using suspended of Pd/C (20 mg) in MeOH (4 ml) with azido compound (100 mg, 0.23 mmol). The reaction mixture was set under H_2 atmosphere and stirred at rt overnight (TLC: DCM/MeOH 10:1). Then, the mixture was filtered over Celite[®] and the filter pad washed with MeOH (4 ml). The solution was concentrated under reduced pressure to give colourless oil of the amino compound (75.0 mg, 0.18 mmol, 70%).

^1H NMR (400 MHz, CDCl_3) δ [ppm]: 5.22-5.14 (m, 2H), 5.04 (t, J 8.8, 1H), 3.85 (dd, J 9.6, 4.3, 1H), 3.72 (dq, J 12.4, 6.2, 1H), 2.97 (t, J 7.5, 2H), 2.14 (s, 3H), 2.06 (s, 3H), 2.01 (s, 3H), 1.86-1.69 (m, 3H), 1.61-1.27 (m, 11H), 1.23 (d, J 6.2, 3H).

Dithiodiglycolic acid (15.0 mg, 0.08 mmol) and SOCl_2 (20 μl , 0.32 mmol) were dissolved in DCM/DMF (10:1 ml), the mixture was refluxed for 3h. The mixture was concentrated under reduced pressure, then dissolved in pyridine (1 ml). Amino compound (46.0 mg, 0.17mmol) was dissolved in pyridine (200 μl) then added dropwise at 0 °C. The reaction mixture was stirred overnight at room temperature under N_2 atmosphere. TLC showed many spots in (DCM/MeOH 1:2).

7.3.2 Attempted The Coupling of Dithiodiglycolic Acid With 8-(1'-Deoxy- α -L-rhamnopyranos-1'yl)-oct-1-amine

Dithiodiglycolic acid (15.0 mg, 0.08 mmol) was dissolved in H_2O (2 ml), amino compound (42 mg, 0.15 mmol) and NHS (20.0 mg, 0.15 mmol) were added and then stirred for 15 min. EDC (30.0 mg, 0.15 mmol) was then added to the reaction mixture. The reaction mixture was stirred overnight at room temperature, TLC (DCM/MeOH 1:2) showed only a light spot of product.

7.3.3 Attempted The Coupling of Dithiodiglycolic Acid With 8-(1'-Deoxy- α -L-rhamnopyranos-1'yl)-oct-1-amine

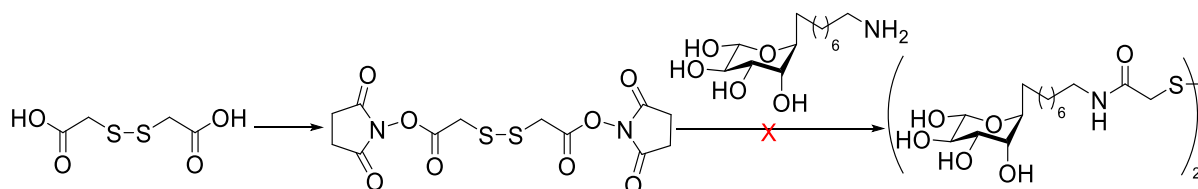

Dithiodiglycolic acid (200.0 mg, 1.1 mmol) was dissolved in 1:1 DCM/acetone (6 ml), NHS (330.0 mg, 2.8 mmol) and DCC (680 mg, 3.3 mmol) were added. The reaction mixture stirred for overnight under N_2 atmosphere. TLC showed a light spot for product. The resultant precipitate was filtered, and the filtrate concentrated under reduced pressure to give the ester as oily compound in 80% (330.0 mg, 0.87 mmol).

^1H NMR (400 MHz, CDCl_3) δ [ppm]: 3.93 (s, 2H), 2.86 (s, 4H).

^{13}C NMR (101 MHz, CDCl_3) δ [ppm]: 168.8, 165.1, 38.7, 25.6.

Amino L-rhamnoside (70.0 mg, 0.25 mmol) and the ester compound (50.0 mg, 0.13 mmol) were dissolved in DMF (500 μ l). Diisopropylethylamine (15.0 mg, 0.12 mmol) was added to the mixture. The mixture was stirred at room temperature for overnight. TLC showed only a spot of the starting material and ^1H NMR also showed only starting material of a sugar.

7.4 Testing The Coupling of Dithiodiglycolic Acid With Propargyl Amine

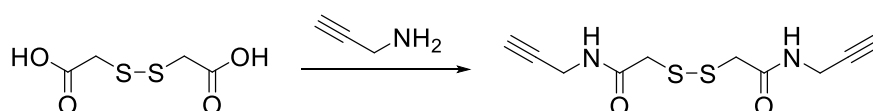

Dithiodiglycolic acid (200.0 mg, 1.1 mmol) dissolved in THF (10 ml), HOBt (200 mg, 1.3 mmol) and DCC (340.0 mg, 1.6 mmol) were added. The mixture was stirred for 3h, white precipitation was formed. Propargyl amine (240.0 mg, 4.4 mmol) was added forming yellow colour. The reaction mixture was stirred for 3h at room temperature. TLC showed a spot of product in (DCM/MeOH 10:1). The mixture was filtered, and the solvent evaporated. The residue was then purified by flash chromatography (DCM/MeOH 10:1) to give a mixture of the product and other compound (245.0 mg, 0.95 mmol, 87%).

^1H NMR (400 MHz, MeOD) δ [ppm]: 4.01 (d, J 2.5, 2H), 3.80 (d, J 2.6, 1H), 3.53 (2H, s), 3.46 (2H, s), 3.07 (t, J 2.6, 1H), 2.60 (t, J 2.5, 1H).

7.5 Testing of Formation of Amide Bond With 2-aminoethane-1-thiol

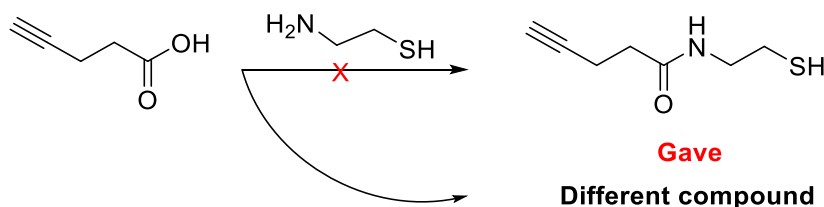

A solution of pent-4-ynoic acid (100 mg, 1.0 mmol) in DMF/H₂O 10:1 (1 ml) was stirred. To this solution HOBt (153.0 mg, 1.0 mmol) and DCC (227.0 mg, 1.1 mmol) were added. White

precipitate was formed and after 30 min, 2-aminoethane-1-thiol (115.0 mg, 1.0 mmol) was added. After 60 min, TLC showed a spot of product in (DCM/MeOH 5:1). The mixture was filtered over celite®, and the solvent was evaporated under the reduced pressure. The residue was purified by flash chromatography (PE/EA 70:30 →1:1) to give another compound in 75% (150 mg, 0.78 mmol).

¹H NMR (400 MHz, CDCl₃) δ [ppm]: 3.47 (dd, *J* 11.2, 6.3, 2H), 3.07 (t, *J* 6.5, 2H), 2.81 (t, *J* 7.2, 2H), 2.58-2.49 (m, 4H), 2.41 (t, *J* 7.0, 2H), 2.03 (dd, *J* 5.8, 2.7, 2H).

7.6 Testing of The Thiol-ene Reaction

7.6.1 Attempted of The Thiol-ene Coupling via AIBN

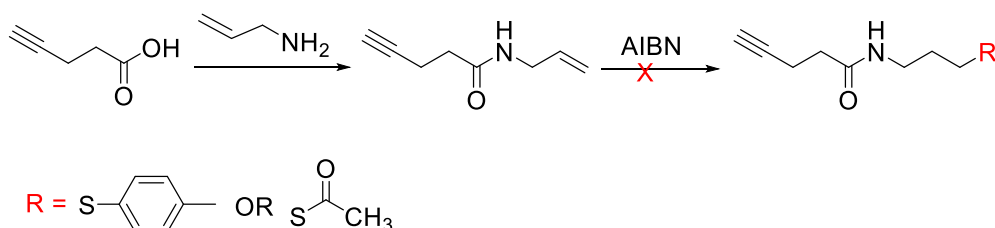

A solution of pent-4-ynoic acid (50 mg, 0.52 mmol) in DCM (4 ml) was stirred under N₂ atmosphere. To this solution HOBt (96.0 mg, 0.62 mmol) and DCC (160.0 mg, 0.78 mmol) were added. White precipitate was formed and after 30 min allyl amine (30 mg, 0.52 mmol) was added. After 60 min, TLC showed a spot of product in (DCM/MeOH 5:1). The mixture was filtered over celite®, and the solvent was evaporated under the reduced pressure. The residue was purified by flash chromatography (DCM 100:0) to give the amide compound in 80% (57 mg, 0.41 mmol).

¹H NMR (400 MHz, CDCl₃) δ [ppm]: 5.84 (ddd, *J* 15.9, 10.7, 5.6, 1H), 5.17 (ddd, *J* 13.7, 11.6, 1.4, 2H), 3.93-3.84 (m, 2H), 2.55 (ddd, *J* 8.8, 4.3, 1.9, 2H), 2.44 (dd, *J* 11.0, 4.0, 2H), 2.04-1.99 (m, 1H).

¹³C NMR (101 MHz, CDCl₃) δ [ppm]: 171.0, 134.2, 116.4, 83.1, 69.4, 42.0, 35.3, 15.0.

Thiocresol (25 mg, 0.2 mmol) was added to a solution of amide compound (21 mg, 0.15 mmol) in THF (1 ml). AIBN (1.7 mg, 0.01 mmol) was added, and the reaction mixture was refluxed for 2h. TLC showed only a spot of starting material.

7.6.2 Testing of The Thiol-ene Reaction

Thiocresol (95 mg, 0.76 mmol) was added to a solution of amide compound (21 mg, 0.15 mmol) in THF (2 ml). AIBN (1.7 mg, 0.01 mmol) was added, and the reaction mixture was refluxed for overnight. TLC showed only a spot of starting material.

7.6.3 Testing of The Thiol-ene Reaction

Thiocresol (255.0 mg, 2.0 mmol) was added to a solution of amide compound (50 mg, 0.36 mmol) in MeOH (2.5 ml). AIBN (2.4 mg, 0.01 mmol) was added, and the reaction mixture was refluxed for overnight. TLC showed also only a spot of starting material.

7.6.4 Testing of The Thiol-ene Reaction

Thioacetic acid (380.0 μ l, 5.5 mmol) was added to a solution of amide compound (50 mg, 0.36 mmol) in Dioxane (2 ml). AIBN (6.0 mg, 0.03 mmol) was added, and the reaction mixture was refluxed for 5h. TLC showed only a spot of starting material. The reaction was worked up with EtOA and purified to give a starting material in 14% (11 mg, 0.05 mmol).

7.6.5 Testing of The Thiol-ene Reaction

Thioacetic acid (260.0 μ l, 3.6 mmol) was added to a solution of amide compound (50 mg, 0.36 mmol) in THF (2 ml). AIBN (10.0 mg, 0.04 mmol) was added, and the reaction mixture was refluxed for overnight. TLC showed only a spot of starting material. The reaction was purified to give a starting material in 20% (16 mg, 0.07 mmol).

7.6.6 Testing of The Thiol-ene Reaction

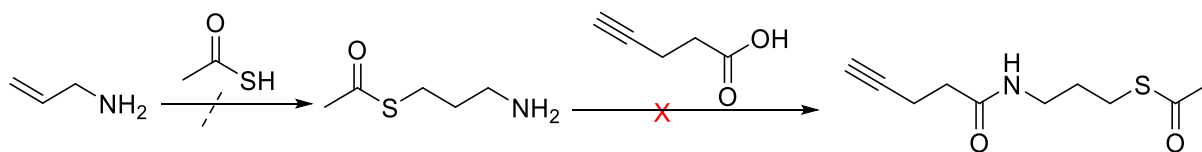

Thioacetic acid (1.3 g, 17.5 mmol) was added to a solution of allyl amine (100 mg, 1.75 mmol) and **AIBN** (30.0 mg, 0.17 mmol) in THF (8 ml). The reaction mixture was refluxed for overnight. TLC showed a spot of the product. The reaction mixture was evaporated and then purified by flash chromatography (EA/PE 80:20) to give the title compound in 70% (¹H NMR was contaminated with thioacetic acid).

¹H NMR (500 MHz, CDCl₃) δ [ppm]: 3.30-3.21 (m, 2H), 2.92 (td, *J* 6.9, 1.2, 2H), 2.35 (d, *J* 1.3, 3H), 2.00 (d, *J* 1.3, 3H), 1.83-1.73 (m, 2H).

In the second step, a solution of pent-4-ynoic acid (145.0 mg, 1.5 mmol) in DCM (4 ml) was stirred under N₂ atmosphere. HOBt (275.0 mg, 1.8 mmol) and DCC (465.0 mg, 2.25 mmol) were added. White precipitate was formed and after 30 min, the product (200 mg, 1.5 mmol) was added. After 2h, TLC showed a spot of starting material. Thus, the reaction left for overnight and TLC also showed a spot of starting material in (PE/EA 1:1).

7.7 Testing of The Click Reaction

7.7.1 Testing The Click Reaction Using Azido-L-rhamnoside

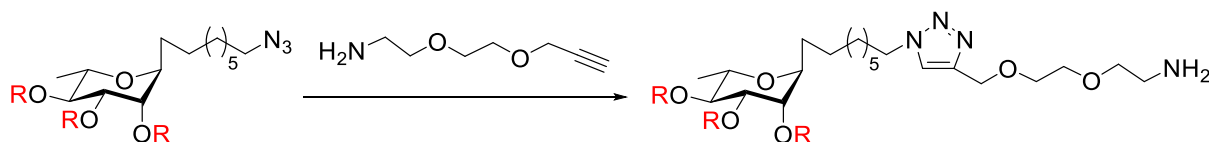

R = H, OAc

An aqueous solution of CuSO₄ (26.0 mg, 0.10 mmol) and an aqueous solution of sodium ascorbate (83.0 mg, 0.42 mmol) in H₂O/THF 1:1 (1 ml) were added subsequently to a yellow solution of azido-L-rhamnoside (50.0 mg, 0.16 mmol) and amino-linker (50.0 mg, 0.35 mmol) in

H₂O (0.5 ml). The reaction mixture was stirred for 1h at room temperature. TLC (MeOH/DCM 5:1) showed a spot of a product. This mixture was then concentrated in vacuum.

The crude was purified by flash chromatography (DCM/MeOH 1:5) to give a product in yield of 20% (15 mg, 0.03 mmol).

7.7.2 Testing of The Click Reaction Using Azido-L-rhamnose

A solution of protected of azido-L-rhamnoside (50.0 mg, 0.11 mmol) in *tert*-BuOH (1 ml) was stirred and a solution of the linker (70 mg, 0.5 mmol) in (0.5 ml) was added. To this mixture, an aqueous solution of CuSO₄ (9.0 mg, 0.03 mmol) and an aqueous solution of sodium ascorbate (20.0 mg, 0.1 mmol) in H₂O (0.5 ml) were added subsequently. The reaction mixture was stirred for 2h at 45°C. TLC (DCM/MeOH 1:5) showed a spot of a product. This mixture was extracted with a little amount of ethyl acetate and then concentrated in vacuum. The crude was purified by flash chromatography (DCM/MeOH 1:2) to give not clean product, in yield of 15% (10 mg, 0.01 mmol).

¹H NMR (400 MHz, CDCl₃) δ [ppm]: 7.57 (s, 1H), 5.18 (d, *J* 7.7, 2H), 5.04 (t, *J* 9.0, 1H), 4.70 (s, 2H), 4.34 (t, *J* 7.0, 2H), 4.21 (s, 1H), 3.75-3.47 (m, 10H), 2.20-1.96 (3 × 3H, s), 1.92 – 1.73 (m, 3H), 1.59-1.27 (m, 11H), 1.23 (d, *J* 6.1, 3H).

7.7.3 Testing of The Click Reaction with Azido-2,3,4-tri-*O*-acetyl-β-*D*-galactoside

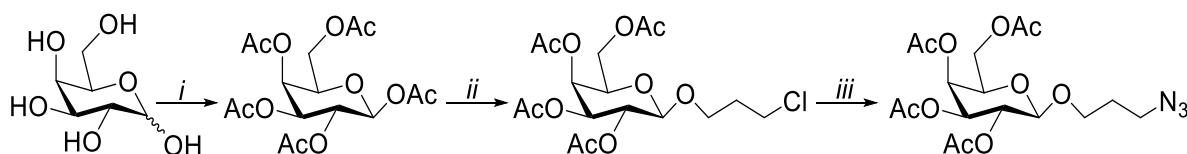

Scheme of the preparation of azido-2,3,4-tri-*O*-acetyl-β-*D*-galactoside. i. (AcO)₂O, NaOAc, 130 °C; ii. 3-chloro-1-propanol, BF₃·OEt₂, DCM, rt, 2h, 84%; iii. NaI, NaN₃, DMF, 130 °C, 1h, 84%.

For azide compound, ¹H NMR (400 MHz, CDCl₃) δ [ppm]: 5.39 (d, *J* 3.1, 1H), 5.19 (dt, *J* 20.4, 10.2, 1H), 5.02 (dd, *J* 10.5, 3.4, 1H), 4.48 (d, *J* 7.9, 1H), 4.16 (m, 2H), 4.01-3.89 (m, 2H), 3.61

(ddd, J 9.6, 8.2, 4.9, 1H), 3.44-3.34 (m, 2H), 2.16 (s, 3H), 2.06 (d, J 7.1, 6H), 1.99 (s, 3H), 1.95-1.76 (m, 2H).

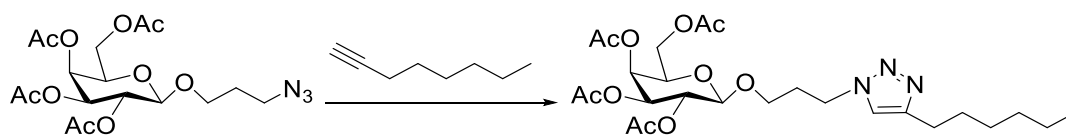

An aqueous solution of CuSO_4 (10.0 mg, 0.04 mmol) and an aqueous solution of sodium ascorbate (15.0 mg, 0.09 mmol) in H_2O (200 μl) were added subsequently to a yellow solution of azido- β -D-galactoside (100.0 mg, 0.23 mmol) and octyne (50.0 μl , 0.34 mmol) in DMF (1.8 ml). The reaction was monitored by TLC (DCM/MeOH 10:1, samples were quenched in EtOAc and H_2O before applied to TLC plate) and a spot of a product appeared after 10 min. After 30 min, TLC did not show any progress. Thus, more of sodium ascorbate (15.0 mg, 0.09 mmol) was added to the reaction. The reaction was monitored by TLC (PE/EtOAc 1:1) and full conversion showed after 1h. The reaction mixture was extracted with EtOAc (10 ml), the organic phase was washed with brine and then concentrated in vacuum. The crude was purified by flash chromatography (PE/EtOAc 70:30) to give a colourless syrup (88.0 mg, 0.20 mmol, 70%).

This reaction was repeated in different equivalents of CuSO_4 (18.0 mg, 0.07 mmol) and sodium ascorbic acid (54.0 mg, 0.27 mmol). The reaction was monitored by TLC (PE/EtOAc 1:1) and full conversion showed after 15 min. The reaction mixture was extracted with EtOAc (10 ml), the organic phase was washed with brine and then concentrated in vacuum. The crude was purified by flash chromatography (PE/EtOAc 70:30) to give a colourless syrup (116.0 mg, 0.27 mmol, 92%).

^1H NMR (400 MHz, CDCl_3) δ [ppm]: 7.28 (s, 1H), 5.38 (d, J 3.0, 1H), 5.21 (dd, J 10.5, 7.9, 1H), 5.01 (dd, J 10.5, 3.4 Hz, 1H), 4.51-4.39 (m, 2H), 4.38-4.28 (m, 1H), 4.13 (dt, J 6.4, 3.3, 2H), 3.88 (dt, J 11.0, 5.9, 2H), 3.46 (ddd, J 9.8, 8.1, 4.5, 1H), 2.73-2.62 (m, 2H), 2.25-2.10 (5H, m), 2.08 (s, 3H), 2.02 (s, 3H), 1.98 (s, 3H), 1.69-1.59 (m, 2H), 1.38-1.24 (m, 6H), 0.86 (t, J 6.8, 3H).

^{13}C NMR (101 MHz, CDCl_3) δ [ppm]: 170.2, 170.0, 169.6, 148.4, 120.9, 101.3, 70.8, 70.7, 68.8, 67.0, 65.9, 61.2, 46.4, 31.5, 30.3, 29.4, 28.9, 25.6, 22.5, 20.8, 20.6, 20.5, 14.0.

References

- 1 J. M. Berg, J. L. Tymoczko, and L. Stryer, *Biochemistry*, W. H. Freeman and Company, New York, 5th edn., 2002.
- 2 L. Warren, *Bound carbohydrates in nature*, Cambridge University Press, 1st edn., 1994.
- 3 J. Nelson and F. M. Beegle, *J. Am. Chem. Soc.*, 1919, **41**, 559-575.
- 4 H. G. Fletcher, *J. Chem. Educ.*, 1940, **17**, 153-156.
- 5 R. S. Tipson, D. Horton, *Advances in carbohydrate chemistry and biochemistry*, Academic Press, 1989.
- 6 M. Sinnott, *Carbohydrate chemistry and biochemistry: structure and mechanism*, Royal Society of Chemistry, 2007.
- 7 I. Cumpstey, *Org. Biomol. Chem.*, 2012, **10**, 2503-2508.
- 8 P. G. Wuts and T. W. Greene, *Greene's protective groups in organic synthesis*, John Wiley & Sons, 2007.
- 9 Y. Zeng, J. Ning and F. Kong, *Carbohydr. Res.*, 2003, **338**, 307-311.
- 10 J. Guo and X. Ye, *Molecules*, 2010, **15**, 7235-7265.
- 11 Y. Zeng, J. Ning and F. Kong, *Tetrahedron Lett.*, 2002, **43**, 3729-3733.
- 12 A. V. Demchenko, *Handbook of chemical glycosylation: advances in stereoselectivity and therapeutic relevance*, John Wiley & Sons, 2008.
- 13 K. Lalitha, K. Muthusamy, Y. S. Prasad, P. K. Vemula and S. Nagarajan, *Carbohydr. Res.*, 2015, **402**, 158-171.
- 14 A. D., McNaught, *Pure Appl. Chem.*, 1996, **68**, 1919-2008
- 15 D. Horton and T. Miyake, *Carbohydr. Res.*, 1988, **184**, 221-229.
- 16 B. P. Gurale, A. N. Dhawane, X. Cui, A. Das, X. Zhang and S. S. Iyer, *Anal. Chem.*, 2016, **88**, 4248-4253.
- 17 J. Zeng, S. Vedachalam, S. Xiang and X. Liu, *Org. Lett.*, 2010, **13**, 42-45.

-
- 18 H. H. Kinfie, F. M. Mebrahtu, M. M. Manana, K. Madumo and M. S. Sokamisa, *Beilstein J. Org. Chem.*, 2015, **11**, 583-588.
 - 19 K. W. Wellington and S. A. Benner, *Nucleosides, Nucleotides, and Nucleic Acids*, 2006, **25**, 1309-1333.
 - 20 C. Bertozzi and M. Bednarski, *Carbohydr. Res.*, 1992, **223**, 243-253.
 - 21 K. Kumar Ponnappalli, A. Kumar Adak, A. Das, J. Song, S. Wu, C. Sun and C. Lin, *Asian Journal of Organic Chemistry*, 2017, **6**, 1308-1321.
 - 22 J. Beignet, J. Tiernan, C. H. Woo, B. M. Kariuki and L. R. Cox, *J. Org. Chem.*, 2004, **69**, 6341-6356.
 - 23 L. Mydock-McGrane, Z. Cusumano, Z. Han, J. Binkley, M. Kostakioti, T. Hannan, J. S. Pinkner, R. Klein, V. Kalas and J. Crowley, *J. Med. Chem.*, 2016, **59**, 9390-9408.
 - 24 K. Lalitha, K. Gayathri, Y. Prasad, R. Saritha, A. Thamizhanban, C. Maheswari, V. Sridharan and S. Nagarajan, *Gels*, 2018, **4**, 1-12.
 - 25 C. Brusa, M. Muzard, C. Remond and R. Plantier-Royon, *RSC Advances*, 2015, **5**, 91026-91055.
 - 26 F. Stauffert, A. Bodlenner, T. M. N. Trinh, M. I. García-Moreno, C. O. Mellet, J. Nierengarten and P. Compain, *New Journal of Chemistry*, 2016, **40**, 7421-7430.
 - 27 A. Dondoni, M. Kleban, H. Zuurmond and A. Marra, *Tetrahedron Lett.*, 1998, **39**, 7991-7994.
 - 28 S. S. Nigudkar and A. V. Demchenko, *Chemical science*, 2015, **6**, 2687-2704.
 - 29 A. T. Carmona, A. J. Moreno-Vargas and I. Robina, *Current Organic Synthesis*, 2008, **5**, 33-60.
 - 30 A. V. Demchenko, E. Rousson and G. Boons, *Tetrahedron Lett.*, 1999, **40**, 6523-6526.
 - 31 J. Park, T. J. Boltje and G. Boons, *Org. Lett.*, 2008, **10**, 4367-4370.
 - 32 Pili Bacteria | www.imagenesmy.com. (Last accessed on 22/10/2018).
 - 33 S. T. Odonkor and J. K. Ampofo, *Microbiology research*, 2013, **4**, 1-7.
 - 34 C. K. Garofalo, T. M. Hooton, S. M. Martin, W. E. Stamm, J. J. Palermo, J. I. Gordon and S. J. Hultgren, *Infect. Immun.*, 2007, **75**, 52-60.
 - 35 C. N. Spaulding and S. J. Hultgren, *Pathogens*, 2016, **5**, 1-18.

-
- 36 D. C. Dodd and B. I. Eisenstein, *J. Bacteriol.*, 1984, **160**, 227-232.
- 37 J. A. Snyder, B. J. Haugen, E. L. Buckles, C. V. Lockett, D. E. Johnson, M. S. Donnenberg, R. A. Welch and H. L. Mobley, *Infect. Immun.*, 2004, **72**, 6373-6381.
- 38 A. R. Brumbaugh and H. L. Mobley, *Expert review of vaccines*, 2012, **11**, 663-676.
- 39 J. Bouckaert, J. Berglund, M. Schembri, E. De Genst, L. Cools, M. Wuhrer, C. Hung, J. Pinkner, R. Slättegård and A. Zavialov, *Mol. Microbiol.*, 2005, **55**, 441-455.
- 40 E. Okragla, K. Szychowska and L. Wolska, *Postepy Hig. Med. Dosw. (Online)*, 2014, **68**, 684-694.
- 41 M. G. Blango, E. M. Ott, A. Erman, P. Veranic and M. A. Mulvey, *PLoS One*, 2014, **9**, 1-9.
- 42 R. Kucheria, P. Dasgupta, S. H. Sacks, M. S. Khan and N. S. Sheerin, *Postgrad. Med. J.*, 2005, **81**, 83-86.
- 43 J. M. Bower, D. S. Eto and M. A. Mulvey, *Traffic*, 2005, **6**, 18-31.
- 44 M. Glover, C. G. Moreira, V. Sperandio and P. Zimmern, *Urological science*, 2014, **25**, 1-8.
- 45 B. Köves and B. Wullt, *European Urology Supplements*, 2016, **15**, 88-94.
- 46 W. J. Allen, G. Phan and G. Waksman, *Curr. Opin. Struct. Biol.*, 2012, **22**, 500-506.
- 47 A. Wellens, C. Garofalo, H. Nguyen, N. Van Gerven and R. Slättegård, *Plos one*, 2008, **3**, 1-13.
- 48 K. A. Kline, S. Fälker, S. Dahlberg, S. Normark and B. Henriques-Normark, *Cell host & microbe*, 2009, **5**, 580-592.
- 49 D. H. Lloyd, J. Viac, D. Werling, C. A. Rème and H. Gatto, *Vet. Dermatol.*, 2007, **18**, 197-204.
- 50 J. D. Schilling, M. A. Mulvey and S. J. Hultgren, *J. Infect. Dis.*, 2001, **183**, S36-S40.
- 51 G. Phan, H. Remaut, T. Wang, W. J. Allen, K. F. Pirker, A. Lebedev, N. S. Henderson, S. Geibel, E. Volkan and J. Yan, *Nature*, 2011, **474**, 49-53.
- 52 A. Busch and G. Waksman, *Philos. Trans. R. Soc. Lond. B. Biol. Sci.*, 2012, **367**, 1112-1122.
- 53 M. A. Schembri, K. Kjaergaard, E. V. Sokurenko and P. Klemm, *J. Infect. Dis.*, 2001, **183**, S28-S31.

-
- 54 S. S. Justice, C. Hung, J. A. Theriot, D. A. Fletcher, G. G. Anderson, M. J. Footer and S. J. Hultgren, *Proc. Natl. Acad. Sci. U. S. A.*, 2004, **101**, 1333-1338.
- 55 K. W. Dodson, J. S. Pinkner, T. Rose, G. Magnusson, S. J. Hultgren and G. Waksman, *Cell*, 2001, **105**, 733-743.
- 56 I. Kałtnik-Prastowska, J. Lis and A. Matejuk, *Glycoconj. J.*, 2014, **31**, 623-636.
- 57 P. Thumbikat, R. E. Berry, G. Zhou, B. K. Billips, R. E. Yaggie, T. Zaichuk, T. Sun, A. J. Schaeffer and D. J. Klumpp, *PLoS pathogens*, 2009, **5**, 1-17.
- 58 R. Spitzer, A. E. Cleves, R. Varela and A. N. Jain, *Proteins: Structure, Function, and Bioinformatics*, 2014, **82**, 679-694.
- 59 A. V. Campoy and E. Freire, *Biophys. Chem.*, 2005, **115**, 115-124.
- 60 K. H. Ebrahimi, P. Hagedoorn, D. Jacobs and W. R. Hagen, *Scientific reports*, 2015, **5**, 1-15.
- 61 A. Wellens, M. Lahmann, M. Touaibia, J. Vaucher, S. Oscarson, R. Roy, H. Remaut and J. Bouckaert, *Biochemistry (N. Y.)*, 2012, **51**, 4790-4799.
- 62 M. Agostino, E. Yuriev and P. A. Ramsland, *Frontiers in immunology*, 2011, **2**, 1-14.
- 63 J. Bouckaert, J. Mackenzie, J. L. De Paz, B. Chipwaza, D. Choudhury, A. Zavialov, K. Manerstedt, J. Anderson, D. Piérard and L. Wyns, *Mol. Microbiol.*, 2006, **61**, 1556-1568.
- 64 M. Almant, V. Moreau, J. Kovensky, J. Bouckaert and S. G. Gouin, *Chemistry—A European Journal*, 2011, **17**, 10029-10038.
- 65 D. Alvarez Dorta, A. Sivignon, T. Chalopin, T. I. Dumych, G. Roos, R. O. Bilyy, D. Deniaud, E. Krammer, J. de Ruyck and M. F. Lensink, *Chembiochem*, 2016, **17**, 936-952.
- 66 M. Touaibia, E. Krammer, T. C. Shiao, N. Yamakawa, Q. Wang, A. Glinschert, A. Papadopoulos, L. Mousavifar, E. Maes and S. Oscarson, *Molecules*, 2017, **22**, 1-18.
- 67 J. Xiao, E. Capanoglu, A. R. Jassbi and A. Miron, *Crit. Rev. Food Sci. Nutr.*, 2016, **56**, S29-S45.
- 68 S. Johnson and F. Tanaka, *Organic & biomolecular chemistry*, 2016, **14**, 259-264.
- 69 M. Aronson, O. Medalia, L. Schori, D. Mirelman, N. Sharon and I. Ofek, *J. Infect. Dis.*, 1979, **139**, 329-332.
- 70 D. Wright and L. Usher, *Current Organic Chemistry*, 2001, **5**, 1107-1131.

-
- 71 D. Deniaud, K. Julienne and S. G. Gouin, *Organic & biomolecular chemistry*, 2011, **9**, 966-979.
- 72 S. G. Gouin, A. Wellens, J. Bouckaert and J. Kovensky, *ChemMedChem: Chemistry Enabling Drug Discovery*, 2009, **4**, 749-755.
- 73 R. Haag, *Multivalency as a chemical organization and action principle*, 2015, **11**, 848-849.
- 74 J. D. Badjić, A. Nelson, S. J. Cantrill, W. B. Turnbull and J. F. Stoddart, *Acc. Chem. Res.*, 2005, **38**, 723-732.
- 75 A. Bernardi, J. Jiménez-Barbero, A. Casnati, C. De Castro, T. Darbre, F. Fieschi, J. Finne, H. Funken, K. Jaeger and M. Lahmann, *Chem. Soc. Rev.*, 2013, **42**, 4709-4727.
- 76 E. Festi, synthesis of anti-adhesives as supportive treatment for recurrent urinary tract infections, MSc Thesis, Bangor University, 2014.
- 77 R. W. Binkley, G. S. Goewey and J. C. Johnston, *J. Org. Chem.*, 1984, **49**, 992-996.
- 78 T. G. Marron, T. J. Woltering, G. Weitz-Schmidt and C. Wong, *Tetrahedron Lett.*, 1996, **37**, 9037-9040.
- 79 K. Nicolaou, C. Hwang and M. Duggan, *J. Am. Chem. Soc.*, 1989, **111**, 6682-6690.
- 80 Y. Ichikawa, M. M. Sim and C. H. Wong, *J. Org. Chem.*, 1992, **57**, 2943-2946.
- 81 D. E. Long, P. Karmakar, K. A. Wall and S. J. Sucheck, *Bioorg. Med. Chem.*, 2014, **22**, 5279-5289.
- 82 K. Ágoston, A. Dobó, J. Rákó, J. Kerékgyártó and Z. Szurmai, *Carbohydr. Res.*, 2001, **330**, 183-190.
- 83 G. Capozzi, C. Ciampi, G. Delogu, S. Menichetti and C. Nativi, *J. Org. Chem.*, 2001, **66**, 8787-8792.
- 84 A. Hosomi, Y. Sakata and H. Sakurai, *Carbohydr. Res.*, 1987, **171**, 223-232.
- 85 Y. Nakagawa, T. Doi, T. Taketani, K. Takegoshi, Y. Igarashi and Y. Ito, *Chemistry—A European Journal*, 2013, **19**, 10516-10525.
- 86 P. R. Skaanderup, C. S. Poulsen, L. Hyldtoft, M. R. Jørgensen and R. Madsen, *Synthesis*, 2002, **2002**, 1721-1727.
- 87 B. Danieli, F. Peri, G. Roda, G. Carrea and S. Riva, *Tetrahedron*, 1999, **55**, 2045-2060.

-
- 88 I. Snajdr, Z. Janousek, J. Jindrich and M. Kotora, *Beilstein J. Org. Chem.*, 2010, **6**, 1099-1105.
- 89 J. A. Love, J. P. Morgan, T. M. Trnka and R. H. Grubbs, *Angewandte Chemie*, 2002, **114**, 4207-4209.
- 90 J. S. Cannon and R. H. Grubbs, *Angewandte Chemie*, 2013, **125**, 9171-9174.
- 91 J. I. Yun, D. Kim and J. Lee, *Tetrahedron Lett.*, 2011, **52**, 1928-1930.
- 92 I. C. Stewart, C. J. Douglas and R. H. Grubbs, *Org. Lett.*, 2008, **10**, 441-444.
- 93 R. Roy, R. Dominique and S. K. Das, *J. Org. Chem.*, 1999, **64**, 5408-5412.
- 94 X. Ding, X. Lv, B. Hui, Z. Chen, M. Xiao, B. Guo and W. Tang, *Tetrahedron Lett.*, 2006, **47**, 2921-2924.
- 95 K. Fujiwara, Y. Suzuki, N. Koseki, S. Murata, A. Murai, H. Kawai and T. Suzuki, *Tetrahedron Lett.*, 2011, **52**, 5589-5592.
- 96 S. Hanashima, Y. Mizushina, T. Yamazaki, K. Ohta, S. Takahashi, H. Koshino, H. Sahara, K. Sakaguchi and F. Sugawara, *Tetrahedron Lett.*, 2000, **41**, 4403-4407.
- 97 C. Murali, M. S. Shashidhar and C. S. Gopinath, *Tetrahedron Lett.*, 2007, **63**, 4149-4155.
- 98 T. Uppal, N. D. K. Bhupathiraju and M. G. H. Vicente, *Tetrahedron*, 2013, **69**, 4687-4693.
- 99 S. H. Hong, D. P. Sanders, C. W. Lee and R. H. Grubbs, *J. Am. Chem. Soc.*, 2005, **127**, 17160-17161.
- 100 A. Dondoni, M. Kleban, H. Zuurmond and A. Marra, *Tetrahedron Lett.*, 1998, **39**, 7991-7994.
- 101 T. Kao, S. Syu, Y. Jhang and W. Lin, *Org. Lett.*, 2010, **12**, 3066-3069.
- 102 W. Binder and W. Schmid, *Monatshefte für Chemie/Chemical Monthly*, 1995, **126**, 923-931.
- 103 P. Neeb, O. Horie and G. K. Moortgat, *Tetrahedron Lett.*, 1996, **37**, 9297-9300.
- 104 G. Zech and H. Kunz, *Chemistry—A European Journal*, 2004, **10**, 4136-4149.
- 105 M. Pérez, P. Canoa, G. Gomez, C. Teran and Y. Fall, *Tetrahedron Lett.*, 2004, **45**, 5207-5209.
- 106 D. A. Evans, H. A. Rajapakse, A. Chiu and D. Stenkamp, *Angew. Chem. Int. Ed.*, 2002, **41**, 4573-4576.
- 107 J. Chang, S. Zhang, Y. Jiang, L. Xu, J. Yu, W. Zhou and X. Sun, *ChemMedChem*, 2013, **8**, 976-984.

-
- 108 G. Zech and H. Kunz, *Angewandte Chemie International Edition*, 2003, **42**, 787-790.
- 109 Y. Liu, L. Ji, M. Eno, S. Kudalkar, A. Li, M. Schimpfen, O. Benchama, P. Morales, S. Xu and D. Hurst, *J. Med. Chem.*, 2018, **61**, 8639-8657.
- 110 L. Auzzas, A. Larsson, R. Matera, A. Baraldi, B. Deschênes-Simard, G. Giannini, W. Cabri, G. Battistuzzi, G. Gallo and A. Ciacci, *J. Med. Chem.*, 2010, **53**, 8387-8399.
- 111 P. Eiselt, K. Y. Lee and D. J. Mooney, *Macromolecules*, 1999, **32**, 5561-5566.
- 112 K. M. Gattás-Asfura and C. L. Stabler, *Biomacromolecules*, 2009, **10**, 3122-3129.
- 113 A. X. Zhang, R. P. Murelli, C. Barinka, J. Michel, A. Cocleaza, W. L. Jorgensen, J. Lubkowski and D. A. Spiegel, *J. Am. Chem. Soc.*, 2010, **132**, 12711-12716.
- 114 D. P. Temelkoff, C. R. Smith, D. A. Kibler, S. McKee, S. J. Duncan, M. Zeller, M. Hunsen and P. Norris, *Carbohydr. Res.*, 2006, **341**, 1645-1656.
- 115 R. J. Mancini, R. C. Li, Z. P. Tolstyka and H. D. Maynard, *Organic & biomolecular chemistry*, 2009, **7**, 4954-4959.
- 116 W. Jintao, X. Jiukai, Li juanjuan, W. Jiali, W. Kerang and L. Xiaoliu, *Chinese Journal of Organic Chemistry*, 2017, **37**, 1407-1411.
- 117 J. B. Park, *Med. Oral Patol. Oral Cir. Bucal*, 2011, **16**, e115-e118.
- 118 Q. Chai, Y. Jiao and X. Yu, *Gels*, 2017, **3**, 1-15.
- 119 B. K. Satheeshbabu and I. Mohamed, *Indian. J. Pharm. Sci.*, 2015, **77**, 579-585.
- 120 D. Saha and S. Bhattacharya, *Journal of food science and technology*, 2010, **47**, 587-597.
- 121 K. K. Hall, K. M. Gattás-Asfura and C. L. Stabler, *Acta biomaterialia*, 2011, **7**, 614-624.
- 122 S. Passemard, L. Szabó, F. Noverraz, E. Montanari, C. Gonelle-Gispert, L. H. Bühler, C. Wandrey and S. Gerber-Lemaire, *Biomacromolecules*, 2017, **18**, 2747-2755.
- 123 J. Yang, Y. Xie and W. He, *Carbohydr. Polym.*, 2011, **84**, 33-39.
- 124 F. Compostella, O. Pitirollo, A. Silvestri and L. Polito, *Beilstein journal of organic chemistry*, 2017, **13**, 1008-1021.
- 125 P. M. Chaudhary, S. Sangabathuni, R. V. Murthy, A. Paul, H. V. Thulasiram and R. Kikkeri, *Chemical Communications*, 2015, **51**, 15669-15672.

-
- 126 S. André, T. Velasco-Torrijos, R. Leyden, S. Gouin, M. Tosin, P. V. Murphy and H. Gabius, *Organic & biomolecular chemistry*, 2009, **7**, 4715-4725.
- 127 I. Annis, L. Chen and G. Barany, *J. Am. Chem. Soc.*, 1998, **120**, 7226-7238.
- 128 J. R. Dunetz, J. Magano and G. A. Weisenburger, *Organic Process Research & Development*, 2016, **20**, 140-177.
- 129 M. D. Joseph, T. Michael, G. E. David and W. S. George, WO2013075227 (A1), page 22.
- 130 E. Riva, D. Comi, S. Borrelli, F. Colombo, B. Danieli, J. Borlak, L. Evensen, J. B. Lorens, G. Fontana and O. M. Gia, *Bioorg. Med. Chem.*, 2010, **18**, 8660-8668.
- 131 A. N. Calabrese, T. Wang, J. H. Bowie and T. L. Pukala, *Rapid Communications in Mass Spectrometry*, 2013, **27**, 238-248.
- 132 J. Su, *Gels*, 2018, **4**, 1-22.
- 133 M. Shibata, N. Ishigami and A. Shibita, *React Funct Polym*, 2017, **118**, 35-41.
- 134 S. A. Svarovsky, Z. Szekely and J. J. Barchi, *Tetrahedron: Asymmetry*, 2005, **16**, 587-598.
- 135 M. E. Condon, E. W. Petrillo Jr, D. E. Ryono, J. A. Reid, R. Neubeck, M. Puar, J. E. Heikes, E. F. Sabo and K. A. Losee, *J. Med. Chem.*, 1982, **25**, 250-258.
- 136 H. Tamura, A. Fujita, M. Steinhaus, E. Takahisa, H. Watanabe and P. Schieberle, *J. Agric. Food Chem.*, 2010, **58**, 7368-7375.
- 137 C. R. Becer, R. Hoogenboom and U. S. Schubert, *Angew. Chem. Int. Ed.*, 2009, **48**, 4900-4908.
- 138 Q. Wang, T. R. Chan, R. Hilgraf, V. V. Fokin, K. B. Sharpless and M. Finn, *J. Am. Chem. Soc.*, 2003, **125**, 3192-3193.
- 139 J. E. Moses and A. D. Moorhouse, *Chem. Soc. Rev.*, 2007, **36**, 1249-1262.
- 140 S. Hotha and S. Kashyap, *J. Org. Chem.*, 2006, **71**, 364-367.
- 141 F. Cataldo and C. S. Casari, *J. Inorg. Organomet Polym. and Materials*, 2007, **17**, 641-651.
- 142 S. Lal and S. Díez-González, *J. Org. Chem.*, 2011, **76**, 2367-2373.
- 143 M. Marradi, F. Chiodo, I. Garcia and S. Penadés, *Chem. Soc. Rev.*, 2013, **42**, 4728-4745.
- 144 O. Han and H. Liu, *Tetrahedron Lett.*, 1987, **28**, 1073-1076.
- 145 O. Milhomme, S. G. Dhénin, F. Djedaïni-Pilard, V. Moreau and C. Grandjean, *Carbohydr. Res.*, 2012, **356**, 115-131

-
- 146 Q. Yin, Q. Chen, L. Lu and B. Han, *Beilstein J. Org. Chem.*, 2017, **13**, 1212-1221.
- 147 J. M. Fréchet and H. H. Baer, *Carbohydr. Res.*, 1975, **42**, 369-372.
- 148 E. L. Jackson and C. Hudson, *J. Am. Chem. Soc.*, 1937, **59**, 1076-1078.
- 149 D. E. Long, P. Karmakar, K. A. Wall and S. J. Sucheck, *Bioorg. Med. Chem.*, 2014, **22**, 5279-5289.
- 150 K. Nicolaou, A. Patron, K. Ajito, P. Richter, H. Khatuya, P. Bertinato, R. Miller and M. Tomaszewski, *Chemistry—A European Journal*, 1996, **2**, 847-868.
- 151 S. Kamiya, S. Esaki and M. Hama, *Agr. Biol. Chem.*, 1967, **31**, 261-266.
- 152 E. Lee, N. Gavin, P. McArdle and D. Cunningham, *Carbohydr. Res.*, 1990, **197**, 270-275.
- 153 L. Zhang, L. Li, S. Bai, X. Zhou, P. Wang and M. Li, *Org. Lett.*, 2016, **18**, 6030-6033.
- 154 Y. Hon, L. Lu, R. Chang, S. Lin, P. Sun and C. Lee, *Tetrahedron*, 2000, **56**, 9269-9279
- 155 J. E. Tungen, M. Aursnes, J. Dalli, H. Arnardottir, C. N. Serhan and T. V. Hansen, *Chemistry—A European Journal*, 2014, **20**, 14575-14578.
- 156 N. Toda, K. Tago, S. Marumoto, K. Takami, M. Ori, N. Yamada, K. Koyama, S. Naruto, K. Abe and R. Yamazaki, *Bioorg. Med. Chem.*, 2003, **11**, 4389-4415.
- 157 E. C. Davison, M. E. Fox, A. B. Holmes, S. D. Roughley, C. J. Smith, G. M. Williams, J. E. Davies, P. R. Raithby, J. P. Adams and I. T. Forbes, *J. Chem. Soc., Perkin Trans.1*, 2002, 1494-1514.
- 158 D. Sabatino and M. J. Damha, *J. Am. Chem. Soc.*, 2007, **129**, 8259-8270.
- 159 J. X. Qiao, D. L. Cheney, R. S. Alexander, A. M. Smallwood, S. R. King, K. He, A. R. Rendina, J. M. Luetzgen, R. M. Knabb and R. R. Wexler, *Bioorg. Med. Chem. Lett.*, 2008, **18**, 4118-4123.
- 160 C. Nóbrega and J. T. Vázquez, *Tetrahedron: Asymmetry*, 2003, **14**, 2793-2801.
- 161 J. Gelas and D. Horton, *Carbohydr. Res.*, 1978, **67**, 371-387.
- 162 K. Nicolaou, C. Hwang and M. Duggan, *J. Am. Chem. Soc.*, 1989, **111**, 6682-6690.
- 163 B. Bertolotti, B. Oroszová, I. Sutkeviciute, L. Kniežo, F. Fieschi, K. Parkan, Z. Lovyová, M. Kašáková and J. Moravcová, *Carbohydr. Res.*, 2016, **435**, 7-18.

-
- 164 R. Y. Tam, S. S. Ferreira, P. Czechura, J. L. Chaytor and R. N. Ben, *J. Am. Chem. Soc.*, 2008, **130**, 17494-17501
- 165 Y. J. Lee, J. Y. Baek, B. Lee, S. S. Kang, H. Park, H. B. Jeon and K. S. Kim, *Carbohydr. Res.*, 2006, **341**, 1708-1716.
- 166 C. R. Bertozzi and M. D. Bednarski, *J. Org. Chem.*, 1991, **56**, 4326-4329.
- 167 V. Belakhov, E. Dovgolevsky, E. Rabkin, S. Shulami, Y. Shoham and T. Baasov, *Carbohydr. Res.*, 2004, **339**, 385-392.
- 168 S. H. Khan, S. A. Abbas and K. L. Matta, *Carbohydr. Res.*, 1990, **205**, 385-397.
- 169 Z. Li, H. Li and M. Cai, *Carbohydr. Res.*, 1999, **320**, 1-7.
- 170 O. Norberg, B. Wu, N. Thota, J. Ge, G. Fauquet, A. Saur, T. Aastrup, H. Dong, M. Yan and O. Ramström, *Carbohydr. Res.*, 2017, **452**, 35-42.
- 171 S. J. Sondheimer, R. Eby and C. Schuerch, *Carbohydr. Res.*, 1978, **60**, 187-192.
- 172 R. A. Urbanek, S. F. Sabes and C. J. Forsyth, *J. Am. Chem. Soc.*, 1998, **120**, 2523-2533.
- 173 X. Wu, X. Tang, M. Xian, P. G. Brauschweiger and P. G. Wang, *Bioorg. Med. Chem.*, 2002, **10**, 2303-2307.
- 174 M. Zunk and M. J. Kiefel, *Tetrahedron Lett.*, 2011, **52**, 1296-1299.
- 175 A. Coelho, P. Diz, O. Caamano and E. Sotelo, *Advanced Synthesis & Catalysis*, 2010, **352**, 1179-1192.
- 176 S. M. Rountree, S. F. Taylor, C. Hardacre, M. C. Lagunas and P. N. Davey, *Applied Catalysis A: General*, 2014, **486**, 94-104.
- 177 C. L. Johnson and Z. Guo, *J. Carbohydr. Chem.*, 2013, **32**, 301-323.
- 178 O. Longin, M. Hezwani, H. van de Langemheen and R. M. Liskamp, *Org. Biomol. Chem.*, 2018, **16**, 5254-5274.
- 179 H. S. Gill, J. N. Tinianow, A. Ogasawara, J. E. Flores, A. N. Vanderbilt, H. Raab, J. M. Scheer, R. Vandlen, S. Williams and J. Marik, *J. Med. Chem.*, 2009, **52**, 5816-5825.
- 180 R. G. Janssen, J. H. Utley, E. Carré, E. Simon and H. Schirmer, *J. Chem. Soc., Perkin Trans.2*, 2001, 1573-1584.
- 181 F. Tran, A. Odell, G. Ward and N. Westwood, *Molecules*, 2013, **18**, 11639-11657.