

## Energy harvesting: An overview of techniques for use within the transport industry

Neil M. White, School of Electronics and Computer Science, University of Southampton, Southampton, Hampshire, SO17 1BJ  
Bahareh Zaghari, Centre for Propulsion Engineering, Cranfield University, Cranfield, Bedfordshire, MK43 0AL

### Abstract

This paper gives an overview of energy harvesting techniques for generating electrical power from ambient energy such as vibration, heat and light. Typically, the electrical power is used to energise sensing systems and their associated communication channels, which are often wireless in nature. The amount of electrical power generated is in the region of tens of micro watts to hundreds of milli watts. The use of assets in service generally results in some form of ageing as a consequence of elevated temperature, chemical degradation, absorption of energetic radiation, mechanical wear, etc. and, as a consequence, as time progresses, the probability of failure increases. In some situations, it may be acceptable on grounds of cost and consequent impact to accept periodic failure and asset replacement while, in many others, such a strategy is unacceptable such that regular maintenance, condition assessment, life prediction and pre-emptive replacement must be carried out. A clear example of this is in connection with mass transport, notably aviation, where the impact of catastrophic failure can be dire. Condition assessment may be achieved through periodic examination or by continuous monitoring but, in many circumstances, the latter approach has much to recommend it. This commonly involves the measurement of relevant parameters and the subsequent export of data for decision making. Such systems require sensors, data logging, communications hardware, etc. plus a source of energy. A broad overview of energy scavenging techniques is presented, along with an assessment of useful materials for each mode of harvesting.

### 1. An introduction to energy harvesting systems

Energy harvesting is the process of translating ambient energy (heat, light, kinetic etc.) into electrical energy that can be used to power devices or systems. In some applications the ambient energy is available continuously, whereas in others it is intermittent. A classic example of the latter is the use of solar cells, which do not receive light during the night and hence require a secondary storage device to retain the electrical energy during times when the input is low or non-existent. Common forms of secondary storage elements include rechargeable batteries, capacitors or supercapacitors, which can typically provide more than 10 times the energy per unit volume than the electrolytic equivalent. A variety of examples of harvesters is shown in Figure 1. Typically, the amount of power generated is limited to a small fraction of a watt and is used for activities such as sensing and signal transmission. The main types of harvesting mechanism will be discussed further.

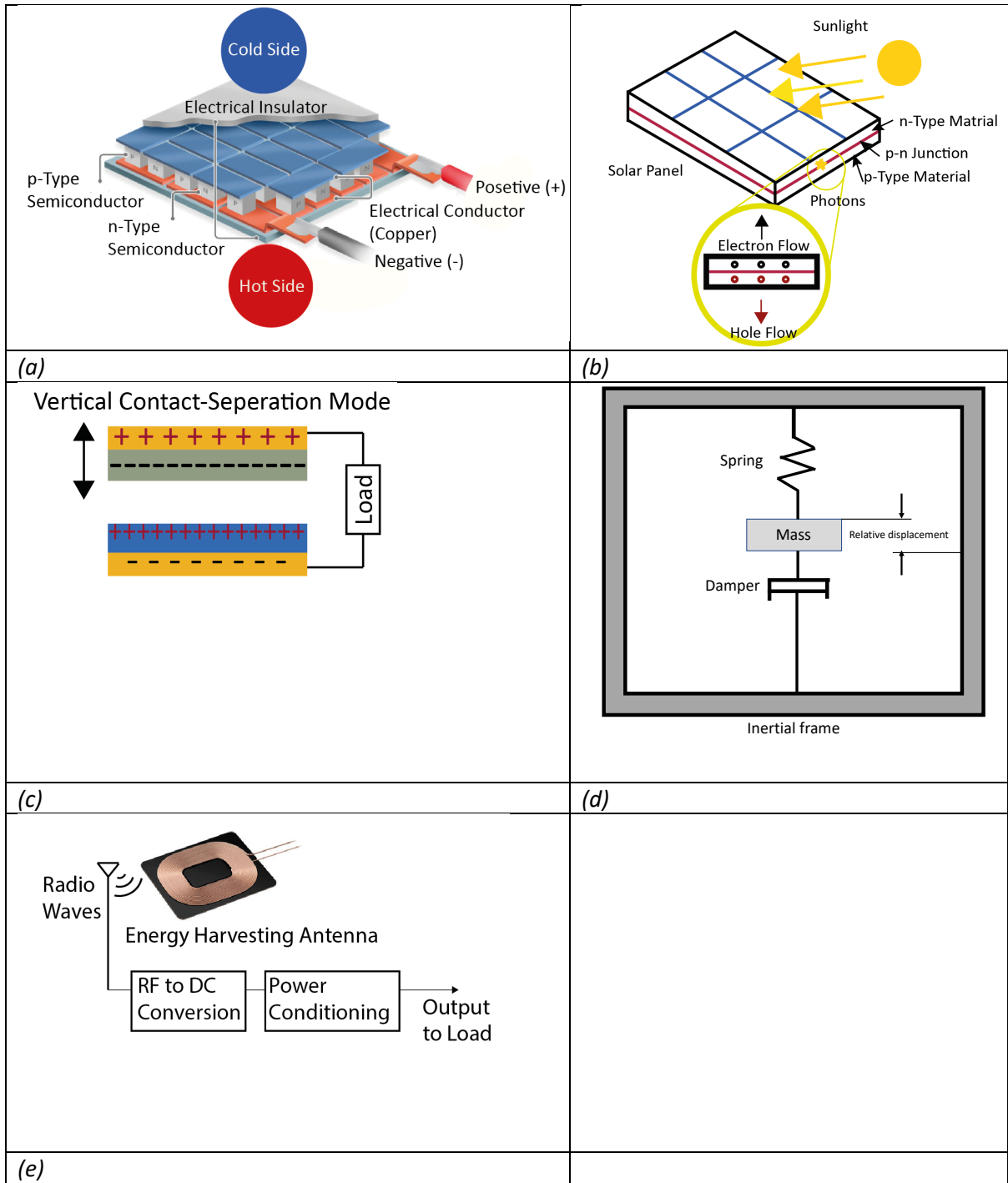

Figure 1. Examples of energy harvesting mechanisms. (a) thermoelectric generator, (b) photovoltaic generator, (c) triboelectric generator, (d) model of a linear, inertial kinetic harvesting generator, (e) radio frequency energy harvesting.

### 1.1 Thermal

Thermal energy is harvested by exploiting the thermoelectric effect, in particular, the Seebeck effect. This is also often used for temperature sensing in the form of thermocouples. It occurs when a junction of dissimilar metals, or semiconductors, is at different temperature to that of the open ends. For thermoelectric generators, it is typical to have an array of semiconductor junctions in order to maximise the electrical power

output, as shown in Figure 1 (a). The Seebeck coefficient,  $\alpha$ , relates the voltage produced to the temperature difference between the 'hot' and 'cold' sides of the generator. A figure of merit,  $Z_T$ , describes the performance of thermoelectric generator and is given by:

$$Z_T = \frac{\alpha^2 \sigma}{k}$$

Where  $\sigma$  is the electrical conductivity (S/m) and  $k$  is the thermal conductivity (W/m·K). Hence for a fixed value of  $\alpha$ ,  $Z_T$  is maximised for materials that possess good electrical conductivity but poor thermal conductivity and there are very few materials with such properties. The value of the Seebeck coefficient is related to the material selected. Typical metals and metal alloys (copper, constantin, iron etc.) have values of up to 100  $\mu\text{V/K}$ . Semiconductors (silicon, germanium) have Seebeck coefficients with values up to 1000  $\mu\text{V/K}$ . These values are often traded off against a deterioration in the value of  $\sigma$  and/or  $k$  and hence optimising  $Z_T$  is not a trivial task.

Additionally, maintaining the temperature difference across the thermoelectric generator (TEG) is often an issue and requires the use of a heat sink, which can occupy a similar volume to that the thermoelectric device. This means that the overall energy density is considerably reduced if the volume of the heat sink is considered. Practical thermoelectric generators are therefore often bulky and generate power levels of a few hundred micro watts per  $\text{cm}^2$  for temperature differences of around  $10^\circ\text{C}$ .

### 1.2 Photovoltaics

Photovoltaic cells are very popular consumer devices that can be used to supplement the electrical supply in domestic scenarios, often capable of generating kilo watts of electrical power. Photovoltaic cells convert natural sunlight (or occasionally artificial light) into electricity by the absorption of photons onto semiconducting substrates, which can use the energy to release electrons (and hence produce current) via the photovoltaic effect as shown in Figure 1 (b). Power densities of a few hundred  $\text{mW/cm}^2$  can be produced in bright sunlight, but this can drop dramatically in poor light conditions. Hence, they have limited use in energy harvesting applications where there is a need to embed the sensor/harvester within a structure (i.e. with no access to a light source).

### 1.3 Triboelectrics

The triboelectric effect refers to the generation of electricity from two materials, which have been in contact with each other. One of the materials will have a tendency to gain electrons, whilst the other will lose electrons. Friction between the two materials (typically polymers such as polyimide, PTFE, PDMS etc.) will produce charge, which can be collected on electrodes. It is often seen in everyday life when experiencing static cling when removing clothes or stroking a cat's fur. Although the triboelectric effect was first discovered over two hundred years ago, its use as an energy harvesting technique has only been exploited within the past decade or so. In terms of energy harvesting, the term TENG, or TriboElectric Nano Generator is often used, indicating that many devices are based on nanomaterials. There are several ways to operate these devices, such as vertical contact separation (Figure 1(c)), lateral sliding or single electrode mode. Typical power densities range from 10 -100  $\text{mW/cm}^3$ .

### 1.4 Kinetic energy

Perhaps the most advanced commercial method of energy harvesting is that which exploits the use of kinetic energy. The Seiko Kinetic watch (1988) [1], is an early example of how the motion of the human arm can be used to power a watch, requiring only a few tens of micro watts to function. The same principles can be adopted to generate differing power levels in different scenarios.

#### 1.4.1 Theory of kinetic energy harvesting

Most examples of kinetic energy harvesting are tailored towards the use of ambient vibrations, which can be converted into electrical power. The vibration energy is coupled to an inertial frame, which transmits the vibrations to a suspended inertial mass. There is a relative displacement between the mass and the reference frame and the overall system therefore has a resonant frequency, which must be matched to that of the vibrations. This can be modelled as a classical spring, mass and damper linear system as shown in Figure 1(d).

The electrical power is generated according to the transduction mechanism employed within the damper. The maximum power that can be extracted when operating at the resonant frequency,  $\omega_n$  is given by [6]:

$$P = \frac{mA^2}{4\omega_n\zeta_T}$$

Where  $m$  is the value of the mass,  $A$  is the applied acceleration and  $\zeta_T$  is the damping ratio of the transducer (damper). This demonstrates that the idea harvester would have a large mass, be excited at a high acceleration level, have a low resonant frequency and a low damping ratio. For practical generators, there will obviously be limits on size, weight and structural geometry impositions.

Essentially, there are three main methods that are commonly used to extract the electrical signal: electromagnetic, piezoelectric and electrostatic as shown in Figure 2. These will be discussed below.

#### 1.4.2 Electromagnetic

This method is based on the principle of electromagnetic induction discovered by Faraday in 1831 and involves the generation of current as a result of a conductor (likely to be a coil) moving in a magnetic field. The amount of electricity generated is a function of the strength of the magnetic field, the velocity of the relative movement and the number of turns in the coil. Many structures comprise a resonating cantilever beam with attached permanent magnets, which act as the seismic mass, positioned around a coil [2].

#### 1.4.3 Piezoelectric

The piezoelectric effect, discovered by J and P Curie in 1880, is found in certain materials that become electrically polarised when they are subjected to mechanical strain. Conversely, the materials deform when subjected to an applied electric field. Piezoelectric materials are available in many forms, including single crystal (quartz, Rochelle salt),

piezoceramic (barium titanate, lead zirconate titanate (PZT)), and polymer materials such as polyvinylidene fluoride (PVDF). Hence, such materials have been investigated for their use in kinetic energy harvesting; of particular interest are those materials exhibiting a high values of charge coefficient, for example the piezoelectric coefficient  $d$ , which describes the charge produced per unit applied force (C/N). Applications studied include human-powered systems using piezoelectrics in shoes [3], cantilever-based vibration harvesters [4] and wave-powered harvesting eels [5].

#### 1.4.4 Electrostatic

Many electrostatic harvesters are based on the principle of moving an electrode configured as part of a parallel capacitor structure. If a voltage exists between the electrodes, then there is an electrostatic force across the capacitor. Hence an external mechanical force can overcome the electrostatic force and result in an increase in the voltage (or charge). There are three main types of structure used in such harvesters: an in-plane varying area of overlap, an in-plane varying gap, or an out-of-plane varying gap [6]. The main drawback of electrostatic generators is the requirement for an initial applied voltage, which means that they require an external energy source before they produce their own electrical output. The advantage of using these harvesters are their broadband responses at low and high frequencies of excitation.

#### 1.4.5 Electrets

An electret is a dielectric material that has a quasi-permanent charge and hence there is an analogy to that of a permanent magnet. Early types of electret were made from wax, which had been melted and polarised under a high dielectric field and allowed to cool to room temperature. Modern electrets are made from types of polymer, glass and ceramics. Micro-Electro-Mechanical Systems (MEMS) electrets can be made from silicon nitride and silicon dioxide. To make a functioning electret, charges need to be implanted into the material. This is usually achieved by applying a high voltage across the sample, often by a corona discharge technique. Electrets can be used as the transduction mechanism in kinetic energy harvesting systems in a similar way to those modes adopted with electrostatic techniques [7]. For example, if the underside of a beam (non-piezoelectric) shown in Figure 2(b) was coated with a metal electrode layer and an electrode were to be mounted in a fixed position underneath, then a variable gap device is developed.

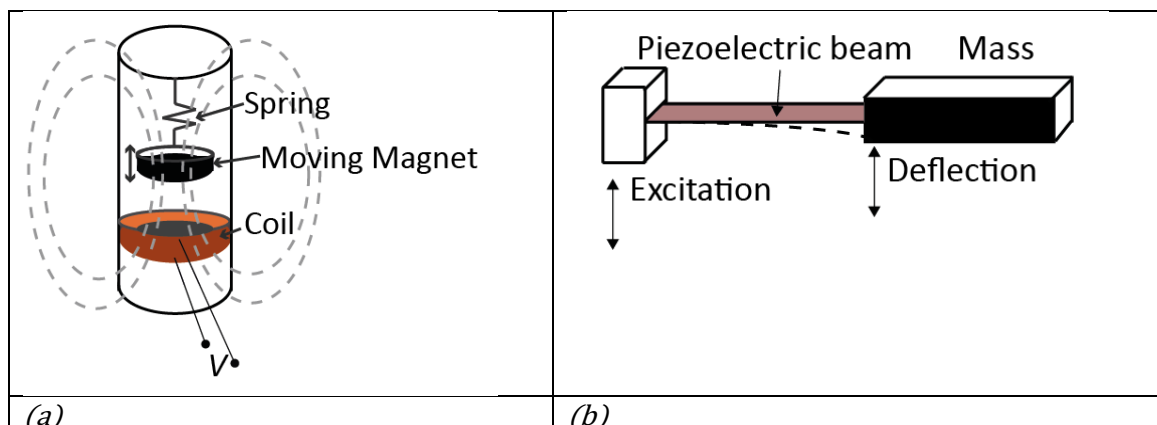

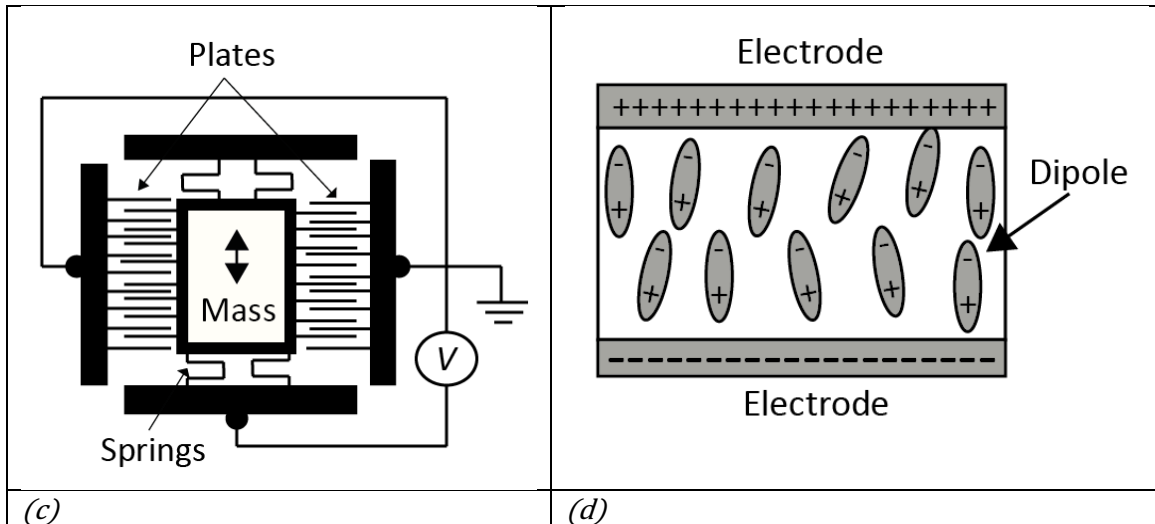

Figure 2. (a) electromagnetic, (b) piezoelectric, (c) electrostatic and (d) electret energy converters.

### 1.5 Ambient electromagnetic

There are two main types of ambient electromagnetic harvesting: wireless charging and radio frequency harvesting. The former has been used as the principle for charging electric toothbrushes for many years. Modern day wireless technologies, such as those used for charging mobile phones, operate over relatively short distances (a few cm). Closely coupled inductive systems require a time-varying magnetic field in one coil to induce a current in a second coil. Additional capacitance is added so that the two coils have the same resonant frequency, thereby ensuring maximum efficiency. Typical charging distances are limited to a few centimetres, but there are some commercial systems that claim to be able to charge over several metres.

Radio frequency (RF) energy harvesting is the process of converting ambient electromagnetic energy into electrical power as shown in Figure 1 (e). An antenna is required for collecting the electromagnetic radiation from the environment and the signal can then be rectified, using an ultrafast diode to convert it to DC. The physical size of the antenna and the need to align it with the transmission source can often pose significant limitations on positioning the systems being powered. The addition of a power management circuit is often need so that the voltage can be regulated and boosted to an appropriate level for powering the associated electronics. The received power varies inversely with distance squared, hence transmission distances are often limited. Pinuela *et al* [8] describe a series of experiments undertaken within an urban or semi-urban environment for frequencies ranging from 0.3 to 3 GHz in the spectrum. They conclude that 50% of the 270 London underground stations could provide sufficient RF energy to power an electronic system, obtaining several  $\mu\text{W}/\text{cm}^3$ .

Table 1. Summary of the power output from energy harvesting devices in e-textiles, non-wearable and large-scale applications.

Energy harvesters	Power output of e-textile devices	Power output of non-textile devices (small scale applications)	Power output of non-textile devices (large scale applications)
Ferroelectricity	5.6 $\mu\text{W}/\text{cm}^2$ [30]	214 $\mu\text{W}/\text{cm}^2$ [31]	n/a
Piezoelectricity	1.1-5.1 $\mu\text{W}/\text{cm}^2$ [32], 1.9 $\mu\text{W}/\text{cm}^3$ [33]	64.9 $\mu\text{W}/\text{cm}^2$ [34]	24 W [39]

Triboelectric	1.88 mW/cm <sup>2</sup> [35], [36]	120 mW/cm <sup>2</sup> [37]	50 mW/cm <sup>2</sup> [40]
Thermoelectric	44.4 μW/cm <sup>2</sup> *[38]	600 μW/cm <sup>2</sup> [38]	1000 W/m <sup>2</sup> [41]
Electromagnetic	8.7–2100 μW/cm <sup>3</sup> [42]	100-300 μW/cm <sup>3</sup> [43]	0.05 W/cm <sup>3</sup> [44]
Electrostatic	0.5–100 μC/cm <sup>2</sup> K [45]	9 μW/cm <sup>2</sup> [46]	n/a
Radio Frequency	PCE=50.5%, at 0.25 μW/cm <sup>2</sup> , at 820 MHz [47]	PCE=50% at 0.22 μW/cm <sup>2</sup> , at 2.4 GHz [48]	n/a
Photovoltaics	PCE=10%, 10 μW/cm <sup>2</sup> [49]	PCE=47.1%, 47.1 μW/cm <sup>2</sup> [50]	1000W/m <sup>2</sup> [51]

Table 1 provides a summary of a variety of different types of energy harvester. Three scenarios include body-worn (e-textiles), off-body and larger scales devices. PCE refers to the Power Conversion Efficiency.

## 2. Energy Harvesting for Next Generation of Aircraft Systems

The desire to build lighter and more efficient aircraft systems in order to reduce fuel consumption and maintenance, has led to an increase in the need for structural health monitoring. Self-powered sensors with energy harvesters can help to reduce weight, maintenance costs and the energy drawn from the aircraft power system. Currently, one way of providing power sources for the electrical component is by using a rotational generator and harvesting the kinetic energy from a gas turbine. To provide flexibility, reduce cabling, and increase the wireless sensing capability inside the aircraft, other forms of energy harvesters have also been studied.

Two categories based on the power level, low-power (μW to mW) and high power (mW to kW) output are considered for aircraft energy harvesting. Thermoelectric, radio frequency [9], piezoelectric [10], electrostatic, triboelectric, electromagnetic induction, variable reluctance [11], and photovoltaic are examples of low-power output sources; regenerative braking and electromagnetic rotational generators are examples of high-power output sources. Low-power output energy harvesters can be used for self-powered sensing and condition health monitoring [12], while high power energy harvesters can be used for propulsion and actuation.

### 2.1 Energy Harvesting for Aircraft Condition Health Monitoring

Thermoelectric generators (TEGs), which convert heat energy into electricity using the Seebeck effect, have been studied more than other energy harvesters for aviation applications [12]. Although these harvesters are compact and robust, they currently have low efficiencies and low power densities. For example, a power density of  $5.26 \text{ W cm}^{-2}$  is achieved with a  $500^\circ\text{C}$  temperature difference between hot and cold sides [13]. Under the ambient temperature variation, the maximum output power can reach 0.6 mW, which corresponds to a power density of  $37.5 \mu\text{W cm}^{-2}$  [14]. The power density is proportional to  $\Delta T^2$  (where T is the temperature difference) and hence the use of thermoelectric generators in aircraft has been limited to powering wireless sensor nodes, which can be used for structural health monitoring [15,16].

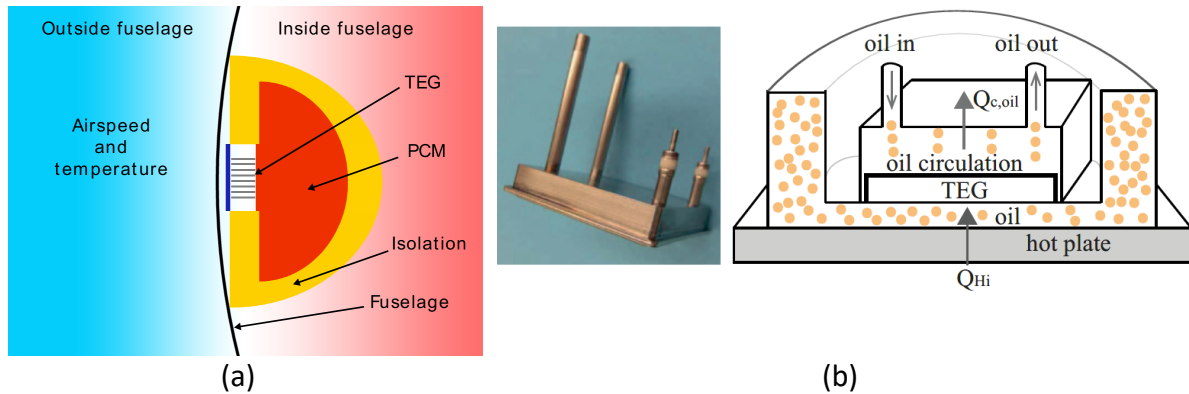

Figure 3. (a) Schematic of a TEG device proposed for energy harvesting and installed close to the front left door of an aircraft for testing during flight [14] (b) Bismuth-telluride TEG from KE-Technologie with internal oil cooling. To simulate the environment inside the aircraft engine, the TEG is tested inside a chamber surrounded by hot oil and it is placed on a hot plate and tested for a simulated flight from London to Frankfurt [15].

Figure 3 shows the example of TEGs being tested for aircraft wireless sensing. Two novel techniques have been adopted to maintain temperature gradient for the TEGs, using a phase change material (PCM) as a heat storage on the hot side (Figure 3(a)) and oil circulation used for bearing lubrication and cooling to cool down the colder side (Figure 3(b)). The PCM is capable of storing and releasing a large amount of heat, which can create temperature difference from transient temperature variation [15]. These examples show that by improving the integration of the TEGs in different applications the overall system efficiency will be increased along with advancement in improving the TEGs figure of merit  $Z_T$ .

## 2.2 Energy Harvesting for Aircraft Propulsion

The concept of the electric aircraft offers many potential benefits but also challenges for the design and overall efficiency of the aircraft. Electrical systems on aircraft have traditionally been powered by hydraulic, mechanical, or pneumatic power sources. By increasing the number of electric components in hybrid, and full electric aircraft, the need for providing energy at different power levels is becoming paramount.

Kinetic energy harvesting has the potential to be used for low-power ( $\mu\text{W}$  to  $\text{mW}$ ) and high power ( $\text{mW}$  to  $\text{kW}$ ) applications. Energy harvesting from regenerative braking has enabled a vehicle's kinetic energy to be converted back to electrical energy during braking or deceleration resulting reduction in fuel consumption [17]. In railway applications, regenerated electricity is fed back to the power supply after being stored in a battery or a supercapacitor [18]. In aviation, regenerative braking can be achieved by using landing gear-based motors during the braking phase or by using propellers as a windmill [19]. The energy generated upon landing can be stored in rechargeable batteries for later use in providing a source for motive power to the aircraft wheels for taxiing and ground manoeuvres of the aircraft [20]. Due to variation in temperature, degradation because of frequent charging and discharging, and limited life of batteries, the maintenance and replacement procedure for the batteries are the limiting factor and more studies are needed to certify these systems. This is one of the main reasons why a technique from



automotive industry cannot directly be applied to aerospace industry and more tests are needed for certification.

Electric taxiing is the concept of avoiding the use of the main aircraft engines on airport taxiways. Instead of burning fuel unnecessarily, the aircraft uses small onboard electric motors to drive the wheels [21]. This is advantageous for airlines, since it can reduce fuel burn by four percent (for the Airbus A320 [22]), reduce expenses and carbon dioxide emissions as well as reducing operating demands from human and material resources. An electrical generator can harvest the excessive power generated by the propeller that is not needed for propulsion during flight. The regenerative possibilities can be achieved by reducing the propeller pitch to use them as wind turbines while flying in rising air currents [23]. A similar concept has been adopted in electric propelled gliders [24]. Electric machines that can perform as a motor and generator can be integrated to the propellers or to be built into the hub of the main gear wheel for regenerative braking by using landing gear-based motors [25]. Permanent magnet machines and switched reluctance machines can operate as either a motor or generator.

Another approach to capture the mechanical energy of propellers as windmill is piezo-windmill excited by rotating magnets as shown in Figure 4. The piezo-windmill has been fabricated and tested for low-speed applications such as wind energy harvesting [26].

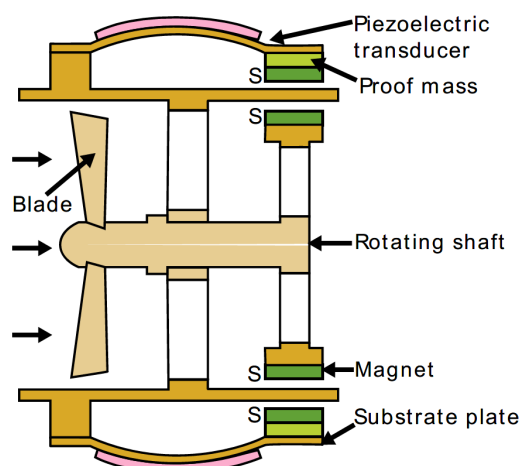

Figure 4. Structure of the piezo-windmill [25], where piezo-cantilevers are excited by the interactive repulsive force between the two magnets, which are located on the rotating part and attached to the piezoelectric device.

In comparison to electrical generators that can produce W to kW range power, the piezoelectric-windmill will generate power in the range of mW to W. The challenges are the integration of the technology and the robustness of the piezoelectric beams under load variations during the life cycle of the energy harvester. However, in comparison with electromagnetic and thermoelectric harvesters, piezoelectric materials are not affected by the change in altitude.

Currently energy harvesting technologies at kilo to megawatt power levels are being researched to identify, capture, store and re-use the energy during flight, braking, and taxiing [27]. Energy harvesting technologies can be developed for hybrid-electric propulsion although issues with electromagnetic interference, partial discharge, and thermal losses need to be studied for high power energy harvesting. Research indicates that emissions within the aviation industry are mainly CO<sub>2</sub> and NO<sub>x</sub> and these can contribute to environmental issues such as global warming. Hence, one of the primary challenges facing the aviation in the coming decades is achieving net zero emissions [28]. Advancement in technologies such as energy harvesting is required and is as important as the development of high-power density batteries and fuel cells, where recyclability and safety aspects are still of concern.

### **3 Energy harvesting for condition monitoring in the rail industry**

Over the past few years, monitoring of the rolling stock and rail tracks using MEMS has become prevalent for monitoring in rail transportation systems, particularly because of their low-power consumption requirements. There is ample vibration energy on the stock and tracks that can be used to power such monitoring systems. A useful location for a vibration harvester is on the axle of the rolling stock, as such devices can be mounted retrospectively and in a simple fashion. A drawback is that running cables to the harvester can be quite tricky and hence wireless techniques for signal transmission need to be adopted. The generators can also be subjected to several tens of 'g' shock levels and hence need to be carefully designed and engineered to survive these, but yet they need to be responsive to the typically milli 'g' levels of vibration that can be used to produce the desired electrical power.

#### **3.1 Case study: Perpetuum Ltd.**

Perpetuum Ltd. ([www.perpetuum.com](http://www.perpetuum.com)) is a spin-out company from the University of Southampton, UK and produces vibration energy harvesting systems mainly for rail industry applications. In the summer of 2020, the company was acquired by Hitachi Rail. Perpetuum's story began as a result of a research project titled "Self-powered microsystems", which was funded from 1999 to 2002 by the UK Engineering and Physical Sciences Research Council (EPSRC). At that time, the phrase "energy harvesting" was not in common use and the research project aimed to assess a variety of different techniques that could be used to energise and obtain a signal from a microsensor system. Wireless sensing protocols such as Bluetooth, ZigBee, LoRaWAN etc. were not commercially available at that time, but the take-up of these has clearly had a major impact on the whole energy harvesting arena. The research project largely focused on the use of piezoelectric and electromagnetic generators, which can produce electrical power from low levels (<1 m/s<sup>2</sup>) of vibration. The preferred solution was an electromagnetic generator capable of producing sub-mW levels of power [29]. The design concept was patented and after obtaining additional investor funding, Perpetuum Ltd. was established in 2004. The initial electromagnetic generator is shown in Figure 5. The generator comprises a cantilever (spring), two pairs of magnets attached at the free end of the cantilever (mass) and a fixed coil (damper), which fits between the magnets. The device also has an adjusting screw that allows the length of the beam to be varied and hence provides a way of varying the resonant frequency of the harvester. The device has now been engineered into a

commercial product that will last for over 10 years without maintenance within a temperature range of  $-40^{\circ}\text{C}$  to  $+85^{\circ}\text{C}$  and is coupled to a wireless sensing system. The system can be easily retrofitted onto rolling stock and can monitor the wheel, bearing and track condition. The harvesters weigh around 1kg and can produce 20 mW of average power from  $2\text{ m/s}^2$  of vibration.

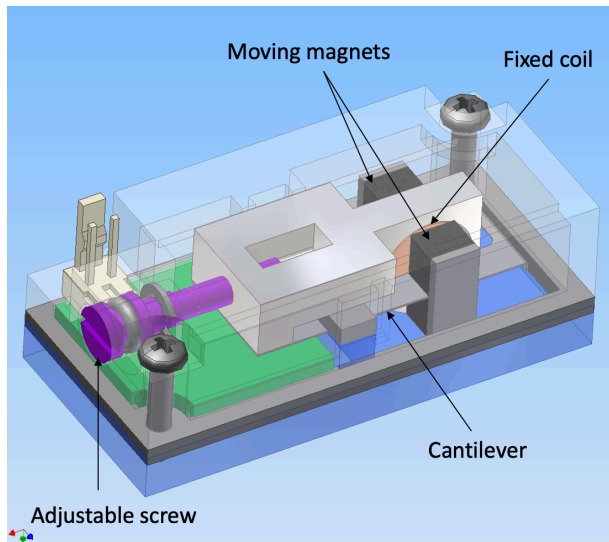

*Figure 5. A prototype electromagnetic vibration harvesting system with a tuneable resonant frequency.*

#### **4 Conclusions**

This paper has reviewed a variety of energy harvesting techniques that have studied by researchers with the aim of generating electrical energy from other forms of ambient energy. Some have not progressed beyond the laboratory, but others have found use in commercial applications. We have also focussed on two application areas that have, hitherto, not been fully exploited: aerospace and rail. Energy harvesting can contribute towards zero carbon targets within these industries, as either alternative forms of power generation or by energising condition monitoring systems that can be used to improve efficiencies in existing equipment or machinery.

The ambient energy cannot always be assumed to be available continuously and hence a secondary storage element is often required. This can take the form of a capacitor, a supercapacitor or even a rechargeable battery. Each of these will occupy a finite volume and hence careful consideration must be given as to whether or not the energy harvesting solution is actually a better use of the available space compared to that of a primary source such as a lithium-ion battery.

## 5 References

---

- [1] <https://www.seikowatches.com/global-en/special/heritage/> [accessed 17/12/2020]
- [2] Glynne-Jones P, Tudor M J, Beeby S P and White N M, 2004, An electromagnetic, vibration-powered generator for intelligent sensor systems *Sensors Actuators A* **110** 344–9
- [3] Starner T 1996 Human-powered wearable computing *IBM Syst. J.* **35** 618–29
- [4] Sodano H A, Park G and Inman DJ, 2004, Estimation of electric charge output for piezoelectric energy harvesting, *Strain* **40** 49–58
- [5] Taylor GW, Burns JR, Kammann SA, Powers WB and Welsh TR, 2001, The Energy Harvesting Eel: a small subsurface ocean/river power generator, *IEEE Journal of Oceanic Engineering*, **26**(4), pp. 539-547, doi: 10.1109/48.972090.
- [6] Beeby SP, Tudor MJ and White NM, 2006, Energy harvesting vibration sources for Microsystems applications, *Measurement Science and Technology*, **17**(12), R175-R195
- [7] Mizuno M and Chetwynd D, 2003, Investigation of a resonance microgenerator *J. Micromech. Microeng.* **13** 209–16
- [8] Pinuela M, Mitcheson P and Lucyszyn S, 2013, Ambient RF Energy Harvesting in Urban and Semi-Urban Environments, *IEEE Transactions on Microwave Theory and Techniques*, **61** (7), 2715 - 2726
- [9] Zhao W, Choi K, Dilli Z, Bauman S, Salter t and Peckerar M, 2011, Design of radio frequency energy harvesting system for an unmanned airplane, *2011 International Semiconductor Device Research Symposium (ISDRS)*, College Park, MD, 2011, pp. 1-2, doi: 10.1109/ISDRS.2011.6135319.
- [10] Wang Y, Yang Z, Li P, Cao D, Huang W, Inman DJ, 2020, Energy harvesting for jet engine monitoring, *Nano Energy*, 2020 May 11:104853.
- [11] Y. Xu, S. Bader and B. Oelmann, 2018, A Survey on Variable Reluctance Energy Harvesters in Low-Speed Rotating Applications, in *IEEE Sensors Journal*, vol. 18, no. 8, pp. 3426-3435, 15 April15, , doi: 10.1109/JSEN.2018.2808377
- [12] Zelenika S, Hadas Z, Bader S, Becker T, Gljušćić P, Hlinka J, Janak L, Kamenar E, Ksica F, Kyratsi T, Louca L, 2020, Energy harvesting technologies for structural health monitoring of airplane components—a review. *MDPI Sensors*. 20(22):6685
- [13] Zhang Y, Cleary M, Wang X, Kempf N, Schoensee L, Yang J, Joshi G, Meda L, 2015, High-temperature and high-power-density nanostructured thermoelectric generator for automotive waste heat recovery. *Energy Conversion and Management*. Nov 15;105:946-50
- [14] Tuoi TT, Van Toan N, Ono T, 2020, Theoretical and experimental investigation of a thermoelectric generator (TEG) integrated with a phase change material (PCM) for harvesting energy from ambient temperature changes. *Energy Reports*. Nov 1;6:2022-9
- [15] Zaghari B, Weddell AS, Esmaeili K, Bashir I, Harvey TJ, White NM, Mirring P, Wang L, 2020 , High Temperature Self-Powered Sensing System for a Smart Bearing in an Aircraft Jet Engine. *IEEE Transactions on Instrumentation and Measurement*, **69** (9), 6165-6174, doi: 10.1109/TIM.2020.2971288
- [16] Elefsiniotis, A., Samson, D., Becker, T and Schmid U, 2013, Investigation of the Performance of Thermoelectric Energy Harvesters Under Real Flight Conditions, *Journal of Electronic Material* **42**, 2301–2305, <https://doi.org/10.1007/s11664-012-2411-0>
- [17] Hartley JA, McLellan RG, Richmond J, Day AJ, Campean IF, 2011, Regenerative braking system evaluation on a full electric vehicle. *Innovations in Fuel Economy and Sustainable Road Transport*, pp. 73-86
- [18] Khodaparastan M, Mohamed AA, Brandauer W, 2019, Recuperation of regenerative braking energy in electric rail transit systems, *IEEE Transactions on Intelligent Transportation Systems*, **11**; 20(8):2831-47
- [19] Sinnige T, Stokkermans T, van Arnhem N, Veldhuis LL, 2019, Aerodynamic Performance of a Wingtip-Mounted Tractor Propeller Configuration in Windmilling and Energy-Harvesting Conditions, In *AIAA Aviation 2019 Forum* (p. 3033)
- [20] Sullivan S, inventor; Delos Aerospace LLC, assignee, 2007, Landing gear method and apparatus for braking and manoeuvring. United States patent US 7,226,018.
- [21] Lukic M, Giangrande P, Hebala A, Nuzzo S, Galea M, 2019, Review, Challenges, and Future Developments of Electric Taxiing Systems, *IEEE Transactions on Transportation Electrification*, **5**(4):1441-57
- [22] <https://www.safran-landing-systems.com/systems-equipment/electric-taxiing-0> [accessed 27/12/2020]
- [23] MacCready P, 1998, Regenerative battery augmented soaring, *Technical Soaring*, 23(1)
- [24] Galvao F. A, Note on Glider Electric Propulsion, *Technical Soaring*. 2012; 36(4):94-101

- [25] Grigore-Müller O, Barbelian M, Regenerative braking for aircraft landing roll phase using an electric machine, In 2012 13th International Conference on Optimization of Electrical and Electronic Equipment (OPTIM) 2012 May 24 (pp. 584-593)
- [26] Kan J, Fan C, Wang S, Zhang Z, Wen J, Huang L, 2016, Study on a piezo-windmill for energy harvesting, *Renewable Energy*. Nov 1;97:210-7
- [27] <https://www.nasa.gov/image-feature/neat-tests-megawatt-scale-electric-aircraft-power-systems> [accessed 27/12/2020]
- [28] Europe JU. Strategic Research and Innovation Agenda 2.0. July 2020
- [29] Glynne-Jones P, Tudor MJ, Beeby SP and White NM, 2004, An electromagnetic, vibration-powered generator for intelligent sensor systems, *Sensors and Actuators A*, **110**(1-3), 344-349
- [30] Luo Z, Zhu D, Shi J, SBeeby SP, Zhang C, Proynov P, and Stark B, Energy harvesting study on single and multilayer ferroelectret foams under compressive force, *IEEE Trans. Dielectr. Electr. Insul.*, **22** (3), pp. 1360\_1368, Jun. 2015, doi: 10.1109/TDEI.2015.7116323.
- [31] Ma X and Zhang X, Low cost electrostatic vibration energy harvesters based on negatively-charged polypropylene cellular films with a folded structure, *Smart Mater. Struct.*, **26**, (8), Jun. 2017, Art. no. 085001, doi: 10.1088/1361-665X/aa75f5.
- [32] Soin N, Shah TH, Anand SC, Geng J, Pornwannachai JW, Mandal P, Reid D, Sharma S, Hadimani RL, Bayramol DV, and Siores E, Novel '3-D spacer' all fibre piezoelectric textiles for energy harvesting applications, *Energy Environ. Sci.*, **7**, (5), pp. 16701679, 2014, doi: 10.1039/C3EE43987A.
- [33] Lund A, Rundqvist K, Nilsson E, Yu L, Hagström B, and Möller C, Energy harvesting textiles for a rainy day: Woven piezoelectrics based on melt-spun PVDF microbres with a conducting core, *npj Flexible Electron.*, **2**, (1), Mar. 2018, Art. no. 1, doi: 10.1038/s41528-018-0022-4.
- [34] Yeo HG, Xue T, Roundy S, Ma X, Rahn C, and Trolier-McKinstry S, Strongly (001) oriented bimorph PZT film on metal foils grown by RF-sputtering for wrist-worn piezoelectric energy harvesters, *Adv. Funct. Mater.*, **28**, (36), Sep. 2018, Art. no. 1801327, doi: 10.1002/adfm.201801327.
- [35] Zhu G, Zhou YS, Bai P, Meng XS, Jing Q, Chen J, and Wang ZL, A shape-adaptive thin-film-based approach for 50% high efficiency energy generation through micro-grating sliding electrification, *Adv. Mater.*, **26**, (23), pp. 3788-3796, Jun. 2014, doi: 10.1002/adma.201400021.
- [36] Wang ZL, Triboelectric nanogenerators as new energy technology and self-powered sensors - Principles, problems and perspectives, *Faraday Discuss.*, **176**, pp. 447-458, Mar. 2014, doi: 10.1039/c4fd00159a.
- [37] Lee C, Yang S, Choi D, Kim W, Kim J, and Hong J, Chemically surface-engineered polydimethylsiloxane layer via plasma treatment for advancing textile-based triboelectric nanogenerators, *Nano Energy*, **57**, pp. 353-362, Mar. 2019, doi: 10.1016/j.nanoen.2018.12.051
- [38] Nozariasbmarz A, Collins H, Dsouza K, Polash MH, Hosseini M, Hyland M, Liu J, Malhotra A, Ortiz FM, Mohaddes F, Ramesh VP, Sargolzaeiaval Y, Snouwaert N, Öztürk MC, and Vashaee D, Review of wearable thermoelectric energy harvesting: From body temperature to electronic systems, *Appl. Energy*, **258**, Jan. 2020, Art. no. 114069, doi: 10.1016/j.apenergy.2019.114069.
- [39] Wu N, Wang Q, Xie, XD, Ocean wave energy harvesting with a piezoelectric coupled buoy structure, *Applied Ocean Research*, **50**, March 2015, pp 110-118, doi: 10.1016/j.apor.2015.01.004
- [40] Wang Y, Liu X, Chen T, Wang H, Zhu C, Yu H, Song L, Pan X, Mi J, Lee C, Xu M, An underwater flag-like triboelectric nanogenerator for harvesting ocean current energy under extremely low velocity condition, *Nano Energy*, **90**, Part A, December 2021, 106503, doi: 10.1016/j.nanoen.2021.106503
- [41] Al-Hababbeh OM, Mohammad A, Al-khalidi A, Khanfer M, Obei M, Design optimization of a large-scale thermoelectric generator, *Journal of King Saud University - Engineering Sciences*, **30**, (2), April 2018, Pages 177-182, doi: 10.1016/j.jksues.2016.01.007
- [42] von Buren T, Mitcheson PD, Green TC, Yeatman EM, Holmes AS, and Troster G, Optimization of inertial micropower generators for human walking motion, *IEEE Sensors J.*, **6**, (1), pp. 2838, Feb. 2006, doi: 10.1109/JSEN.2005.853595
- [43] Lee H and Roh J-S, Wearable electromagnetic energy harvesting textiles based on human walking, *Textile Res. J.*, **89**, (13), pp. 2532-2541, Jul. 2019, doi: 10.1177/0040517518797349.
- [44] Lin, T, Pan Y, Chen S, Zuo L, Modeling and field testing of an electromagnetic energy harvester for rail tracks with anchorless mounting, *Applied Energy*, **213**, (1), March 2018, pp 219-226, doi: 10.1016/j.apenergy.2018.01.032
- [45] Roundy S, On the effectiveness of vibration-based energy harvesting, *J. Intell. Mater. Syst. Struct.*, **16**, (10), pp. 809-823, Oct. 2005, doi: 10.1177/1045389X05054042.
- [46] Post ER, and Waal K, Electrostatic power harvesting for material computing, *Pers. Ubiquitous Comput.*, **15**, (2), pp. 115-121, Feb. 2011, doi: 10.1007/s00779-010-0313-9.

- 
- [47] Wagih M, Weddell AS, and Beeby SP, Omnidirectional dual-polarized low-profile textile rectenna with over 50% efficiency for sub- $\mu\text{W}/\text{cm}^2$  wearable power harvesting, *IEEE Trans. Antennas Propag.*, **69**, (5), pp. 2522-2536, May 2021, doi: 10.1109/TAP.2020.3030992.
- [48] Sun H, Guo Y-X, He M, and Zhong Z, Design of a high efficiency 2.45-GHz rectenna for low-input-power energy harvesting, *IEEE Antennas Wireless Propag. Lett.*, **11**, pp. 929-932, 2012, doi: 10.1109/LAWP.2012.2212232
- [49] Fu X, Sun H, Xie S, Zhang J, Pan Z, Liao M, Xu L, Li Z, Wang B, Sun X, and Peng H, A ber-shaped solar cell showing a record power conversion efficiency of 10%, *J. Mater. Chem. A*, **6**, (1), pp. 45-51, Dec. 2018, doi: 10.1039/C7TA08637G
- [50] Green MA, Dunlop ED, Levi DH, Hohl-Ebinger J, Yoshita M, and Ho-Baillie AWY, Solar cell efficiency tables (version 54), *Prog. Photovolt., Res. Appl.*, **27**, (7), pp. 565-575, Jul. 2019, doi: 10.1002/pip.3171
- [51] Wu N, Wang Q and Xie XD, Ocean wave energy harvesting with a piezoelectric coupled buoy structure, *Applied Ocean Research*, **50**, March 2015, Pages 110-118, doi: 10.1016/j.apor.2015.01.004