

PAPER • OPEN ACCESS

## System architectures for thermal management of hybrid-electric aircraft - FutPrint50

To cite this article: Walter Affonso Jr. *et al* 2022 *IOP Conf. Ser.: Mater. Sci. Eng.* **1226** 012062

View the [article online](#) for updates and enhancements.

You may also like

- [Microstructural development in nanostructured AlCoCrFeNi-ZrO<sub>2</sub> high-entropy alloy composite prepared with mechanical alloying and spark plasma sintering methods](#)  
M Ghanbariha, M Farvizi and T Ebadzadeh
- [Thermal Management challenges for HEA – FUTPRINT 50](#)  
Walter Affonso, Ricardo Gandolfi, Ricardo Jose Nunes dos Reis et al.
- [Corrosion Behavior and Passive Film Characterization of Fe<sub>50</sub>Mn<sub>30</sub>Co<sub>10</sub>Cr<sub>10</sub> Dual-Phase High-Entropy Alloy in Sulfuric Acid Solution](#)  
Yi-Sheng Lu, Che-Wei Lu, Yi-Ting Lin et al.



The Electrochemical Society  
Advancing solid state & electrochemical science & technology

242nd ECS Meeting

Oct 9 – 13, 2022 • Atlanta, GA, US

Abstract submission deadline: **April 8, 2022**

Connect. Engage. Champion. Empower. Accelerate.

**MOVE SCIENCE FORWARD**



Submit your abstract



# System architectures for thermal management of hybrid-electric aircraft - FutPrInt50

Walter Affonso Jr.<sup>1</sup>, Renata T. Tavares<sup>1</sup>, Felipe R. Barbosa<sup>2</sup>, Ricardo Gandolfi<sup>1</sup>, Ricardo J. N. dos Reis<sup>2</sup>, Carlos R. I. da Silva<sup>1</sup>, Timoleon Kipouros<sup>3</sup>, Panagiotis Laskaridis<sup>3</sup>, Hossein Balaghi Enalou<sup>3</sup>, Andrei Chekin<sup>4</sup>, Aleksey Kukovinets<sup>4</sup>, Konstantin Gubernatorov<sup>4</sup>, Yury Ravikovich<sup>5</sup>, Nikolay Ivanov<sup>5</sup>, Leonid Ponyaev<sup>5</sup>, Dmitry Holobtsev<sup>5</sup>

<sup>1</sup>Embraer S.A., Rodovia Presidente Dutra, Km 134, São José dos Campos, 12247-004, Brazil

<sup>2</sup>Embraer Portugal, Parque Da Indústria Aeronáutica De Évora, Herdade De Pinheiro E Casa Branca Lt. A-I, Horta Das Figueiras, Évora, CM1094, Portugal

<sup>3</sup>Cranfield University, College Road, Cranfield, MK43 0AL, United Kingdom

<sup>4</sup>State Research Institute of Aviation Systems (GosNIIAS), Viktorenko street, 7, Moscow, 125319, Russia

<sup>5</sup>Moscow Aviation Institute (MAI), Volokolamskoe shosse, 4, Moscow, 125993, Russia

E-mail: walter.affonso@embraer.com.br, renata.tavares@embraer.com.br, felipe.reyes@pt.embraer.com, ricardo.gandolfi@embraer.com.br, rjreis@embraer.fr, carlos.ilario@embraer.com.br, t.kipouros@cranfield.ac.uk, p.laskaridis@cranfield.ac.uk, hb.enalou@cranfield.ac.uk, aychekin@2100.gosniias.ru, avkukovinec@2100.gosniias.ru, kngubernatorov@2100.gosniias.ru, yr@mai.ru, n.s.ivanov@gmail.com, plp@mai.ru, nio203@mai.ru

**Abstract.** Electric and Hybrid-Electric Aircraft (HEA) propulsion system designs shall bring challenges at aircraft and systems level, mainly in propulsion, electric and thermal management systems (TMS). The electrification of the propulsion system relies on large and high-power electrical equipment (e.g., electrical motors, converters, power electronics, batteries, and others) that dissipate heat at a rate at least one order of magnitude higher than conventional propulsion aircraft systems. As a result, high impacts on weight, drag and power consumption of the TMS/cooling systems at the aircraft level are expected. This paper proposes potential technologies to perform the thermal management of future electric and HEA, in the context of FUTPRINT50 project. For each technology, relevant aspects such as its integration to aircraft, safety, operational and maintenance impacts, certification, technologies readiness level (TRL) and the latest research works are analysed. A quantitative comparison of the several technologies is also proposed considering weight, volume, electric power consumption, pneumatic air flow and cooling air flow per cooling effect. Lastly, we present a set of potential TMS architectures for HEA.

## 1. Introduction

Recently published important reports, such as *AR6 Climate Change 2021* [1], already brought up the evidence of human influence on climate change. In order to minimize impacts on biodiversity and to control the green house effect, many industry sectors are setting strict requirements on the emission of gases on the atmosphere, and the aviation industry, naturally, follows this trend.



Currently, aviation is responsible for approximately 2% of global CO<sub>2</sub> emissions [2], but, as the global air traffic is in constant growth, these emissions are expected to increase. Moreover, other gases with detrimental impacts on climate change are also emitted during aircraft operations, such as sulphur oxides (SO<sub>x</sub>), nitrogen oxides (NO<sub>x</sub>) and water vapor [3]. That makes aviation an important player on the pursuit for a sustainable future. Under the same effort, the FlightPath 2050 report [4], for example, came up with several environmental goals for aircraft operations on Europe, linked not only to emissions, but also to noise pollution. The report sets the concerning with environment and life quality as an essential part of any aeronautical project in the continent from now on.

In this context, FutPrInt50 project emerges as an important initiative to address solutions to the technical challenges that aerospace industry will face to achieve those strict operational environmental goals. It aims to develop a synergetic hybrid-electric aircraft (HEA) to transport up to 50 passengers, with entry in service expected by 2035/2040 [5].

One of the most challenging technical issues in HEA is how to manage the heat generated during its operation, since the electric and electronic equipment from the hybrid-electric propulsive architecture requires a great amount of power to work. This results in very high heat dissipation [6], and removing this residual heat from the aircraft may have significant impacts in weight, drag, electric power consumption and costs, putting in risk the concept's feasibility. The system responsible for rejecting this dissipated heat is the *thermal management system* (TMS), and in a formal definition, it aims at managing the heat transfer between heat sources and sinks to control the temperature of aircraft subsystems/components in order to achieve comfort, safety and efficiency.

As TMS is essential to HEA feasibility, FutPrInt50 project is also committed to study it. Some previous results had already been achieved and are described in [6]. They consist on a high level selection of potential cooling technologies to compose TMS and their respective TRLs (Technology Readiness Level). This paper focus on advancing from those previous results to develop conceptual TMS architectures to HEA.

## 2. Cooling Technologies Methodology Research

In order to advance on this research, it was essential to grasp the integration of the cooling technologies described in [6], not only for designing the TMS architectures in a proper way, but also to achieve greater efficiency. Invariably, this would require a deeper knowledge of the selected cooling technologies, their main characteristics, safety issues, common working fluids, modeling challenges, and others. Thus, the team focused on methodically acquiring this key information, through a *Cooling Technologies Assessment Sheet*.

All information provided to the sheet came from public information and FutPrInt50 participants' experience. The main qualitative and quantitative information obtained on this sheet are presented in topic 3.

## 3. Results and Discussion

### 3.1. Qualitative Data

Since many studied technologies have a low or medium TRL (lower than 6), several questions were still to be answered about them in terms of aircraft impact on operational routine at airports, integration impact on other aircraft subsystems, safety, maintenance, and others. Moreover, as the schedule is a mandatory restriction of any engineering project, it was also important to understand the consortium experience on the evaluated technologies. This could define specific TMS architectures as more or less challenging, depending on the partners previous knowledge on it, for example.

The qualitative information gathered on the *Cooling Technologies Assessment Sheets* are a first attempt to clarify some of those questions, classifying each cooling technology in

terms of reliability (presence or absence of moving parts and/or a more frequent necessity of maintenance), aircraft operations and integration impact and consortium experience. The compliance of each technology with the REACH regulation was also analysed, but no potential conflicts were identified. The research results are shown on table 1.

Table 1: Qualitative information of the considered cooling technologies.

Potential TMS Technologies	Reliability	Aircraft Operations Impact	Aircraft Integration Impact	Consortium Experience
Absorption Refrigerator	Medium	High	High	Low
Air Cycle Machine	High	Low	High	High
Forced Air Cooling	High	Low	Low	High
Joule-Thomson Effect	High	High	High	Low
Liquid Cooling	High	Low	High	Medium
Magnetocaloric Effect	Medium	High	High	Low
Passive Devices	High	High	High	Medium
Phase Change Materials	Medium	High	Low	Low
Skin Heat Exchanger	High	High	High	High
Vapour Cycle System	High	Low	Low	High
Vortex Tube	High	High	High	Low
Thermoelectric Effects	High	Low	Low	Low
Cryocooling Systems	Medium	High	High	High

### 3.2. Quantitative Data

The quantitative data gathered helped the team to have a glimpse on the weight, volume, electric power consumption, bleed air consumption (pressurized air extracted directly from the gas turbine) and cooling air consumption (commonly called ram air) of each technology, in relation to a certain amount of cooling capacity. These proportions, presented on figures 1 and 2 and , are essential to make an initial comparison between the technologies and a simplified analysis of their feasibility.

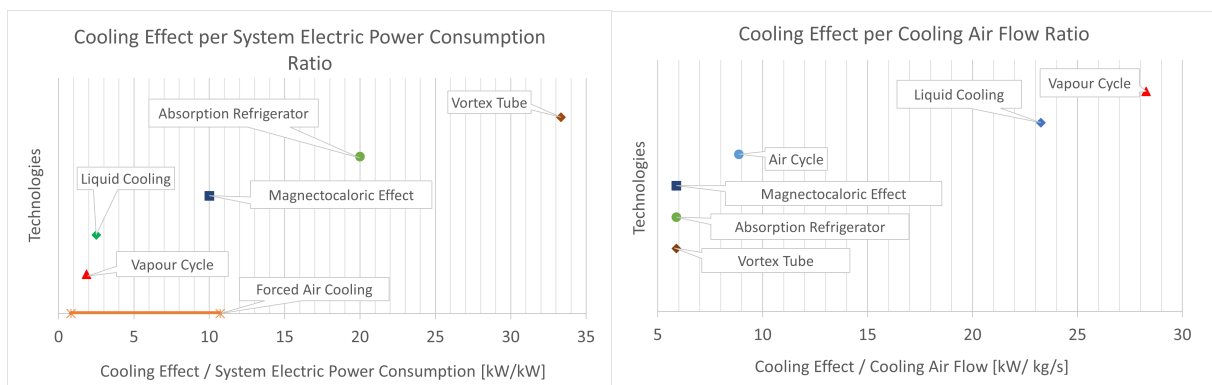

Figure 1: Cooling effect by system electric power consumption (left) and cooling air flow (right).

The lines on the graphs represent a possible variation of the ratio depending on the designed system. So, for example, in figure 2, the forced air cooling line represents the large number of fans available in the market that can have higher or lower ratios of cooling capacity by weight.

It is worth mentioning that these ratios are highly dependent on the selected application, and not all of the studied technologies have prototypes implemented on aeronautical environment. This fact adds an important uncertainty to the collected ratios. For example, the magnetocaloric effect data exposed here was collected from prototypes of magnetic refrigerators that may not be adapted to aeronautical use. Using a magnetic refrigerator in an aircraft could require additional systems that may result in higher weight for example, and this additional weight will not be appropriately represented on magnetocaloric effect line in figure 2.

Moreover, these numbers were collected on current prototypes and/or models and they do not take into account possible future improvements. The data shown are derived mainly from references [7], [8], [9], [10], [11], [12], [13], [14] and [15].

3.3. Conceptual TMS Architectures Proposed

From the technologies in [6] and table 1, five TMS conceptual architectures were developed (topic 3.3.1 to 3.3.5), based on different hybrid-electric propulsion concepts that have been studied in FutPrInt50 project: sustainable aviation fuel (SAF) gas turbine (GT) with electric motor (EM) in parallel (figure 3 left); liquid hydrogen fuel cell and electric battery in series (figure 3 right); and liquid hydrogen gas turbine - that can be driven by electric motors - in parallel with another set of electric motors, fed by a battery pack in series with a liquid hydrogen fuel cell (figure 3 centre).

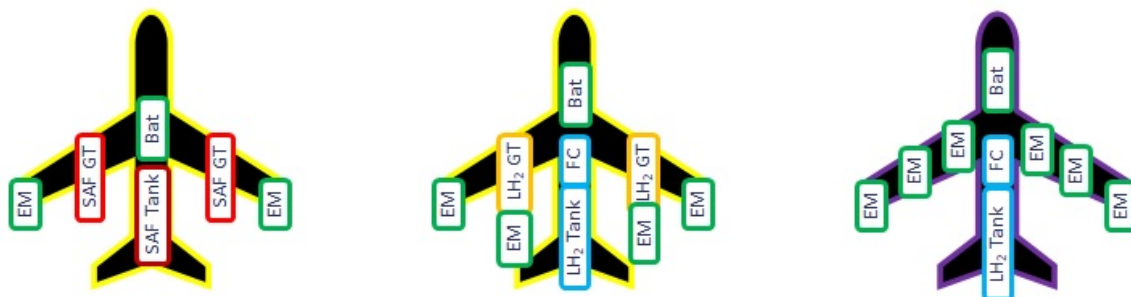

Figure 3: Proposed propulsion concepts.

3.3.1. Embraer - Liquid Cooling with Vapour Cycle The architecture shown in figure 4 is an integration between a liquid cooling loop (with ethylene glycol and water mixture



The cooling effect from the evaporation process can be used to cool the secondary heat carrier (an ethylene glycol water mixture, for example), which will absorb heat from the power electronics and the pressurized cabin. Considering a scenario where a VCS is the main responsible for the cooling of cabin air, the absorption refrigerator will decrease the VCS evaporator heat load, and consequently, the compressor electric consumption. The secondary heat carrier may need additional cooling by means of the ram-air/liquid heat exchanger, which can be used as the only cold source of the architecture at a sufficiently low external temperature.

**3.3.4. Embraer - Hydrogen** The TMS described in Figure 7 was developed taking into consideration the use of a hydrogen fuel cell as part of the propulsion system, in series with electrical propulsion. The liquid hydrogen (LH2) is stored at cryogenic temperatures but needs to reach the fuel cell (FC) in the correct temperature, that depends on the FC type [16] [17]. Hence, it must exchange heat with the EGW (ethylene glycol and water mixture) at the HX/Evaporator before reaching the cell. Constant pressure must also be ensured at the FC for its correct operation [16]: this can be achieved by bleeding part of the compressed air from the cabin to the cell.

The EGW that flows through the HX/Evaporator is distributed through a manifold to a set of different pipes: one that goes to the fuel cell and a set that goes through an evaporator before being forced through the electronics, batteries and electric motors.

**3.3.5. MAI - Cryo Cooling** Cryocooling refers to all cooling systems that achieve cryogenic temperatures (65 to 75 K). They can be based on Stirling, Gifford McMahon or Joule Thomson cycles and are used mainly with high temperature superconducting (HTS) components, which can achieve a state of superconductivity (severe decrease of electrical resistance) when exposed to these cryogenic temperatures. A potential gain of using cryocooling would be a weight reduction related to aircraft electrical components (such as electric motors and cables), by exposing it to temperatures that could decrease significantly their electrical resistance. With less electrical losses, the size of these equipment could be reduced. As hydrogen for power generation is stored under low temperature and high-pressures, it reaches temperatures that make it adequate for cryocooling. An example of an experimental setup for cryocooling based on the reverse Brayton cycle is shown on Figure 8.

The fluid is compressed at compressor  $K_1$  and goes through the heat exchanger  $AT_1$ , where its energy is extracted by a refrigerant. It then goes through two other sets of compressors and heat exchangers ( $K_2 - AT_2$  and  $K_3 - AT_3$ ) before going inside the recuperative cooling thermal unit ( $TA_p$ ). Finally, the fluid expands and loses energy (as work) at the turbine  $T_D$ , absorbs the heat load ( $Q$ ) at the exchanger  $TA_H$  and flows back into the recuperative unit before re-starting the cycle at compressor  $K_1$ .

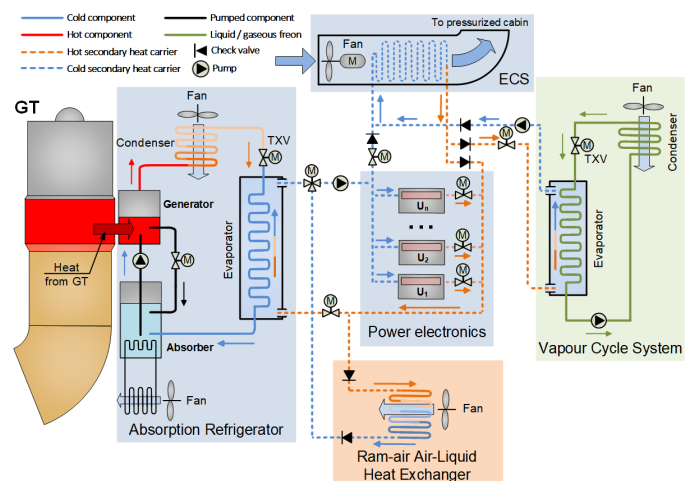

Figure 6: TMS conceptual architecture based on an absorption refrigeration cycle.

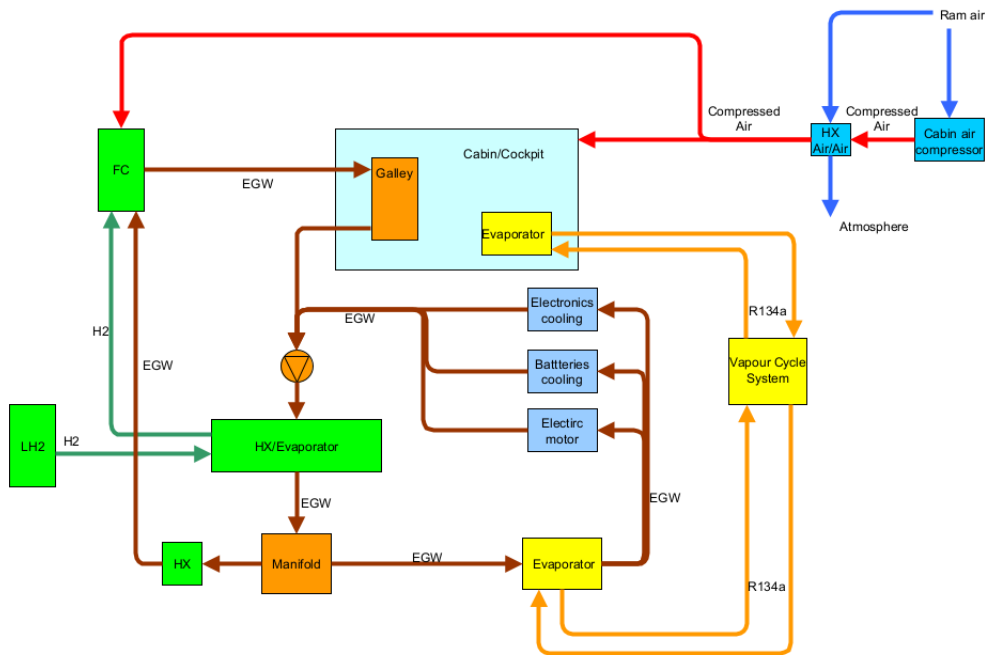

Figure 7: TMS architecture based on a liquid hydrogen (LH2) fuel cell.

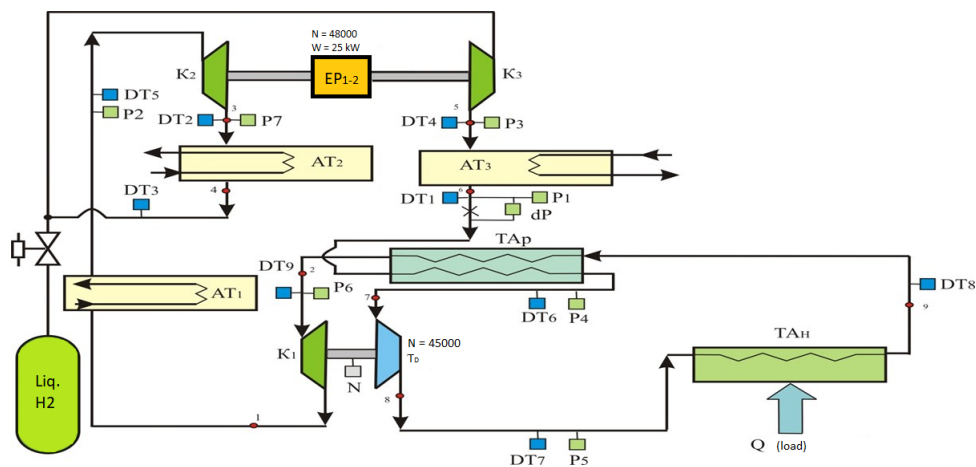

Figure 8: Cryocooling system based on the reverse Brayton cycle.

#### 4. Conclusion

Thermal management systems architecture and features will be highly dependent on the propulsion concept adopted for each aeroplane. There are still many unknowns: from what propulsion type will be more adequate to the mission proposed, to integration challenges that have not yet been predicted (unknown *unknowns*). In addition, applications of these technologies to the aerospace sector are still emerging and, therefore, some technologies are still not mature enough. Likewise, the regulatory agencies are working on special conditions and/or means of compliance capable of embracing these new systems without compromising flight safety.

Future work will focus on modelling and simulation of the proposed architectures at system and aircraft levels. In order to do this, the aircraft propulsion system requirements are being developed and are essential to the assessment of the conceptual architectures.



Once more mature TMS architectures have been established, it will be possible to clarify the suitability of the thermal systems and their main weaknesses and strengths. Having done it, the complexity of the computational models will be increased and, eventually, integrated to an aircraft-level simulation environment in SUAVE [18].

## References

- [1] Zhongming Z, Linong L, Wangqiang Z, Wei L, et al. AR6 Climate Change 2021: The Physical Science Basis; 2021.
- [2] Strouhal M. CORSIA-Carbon Offsetting and Reduction Scheme for International Aviation. MAD-Magazine of Aviation Development. 2020;8(1):23–28.
- [3] Larkens R. A coupled propulsion and thermal management system for hybrid electric aircraft design: A case study. TU Delft. Mekelweg 5, 2628 CD Delft, Netherlands; 2020.
- [4] Krein A, Williams G. Flightpath 2050: Europe’s vision for aeronautics. Innovation for Sustainable Aviation in a Global Environment: Proceedings of the Sixth European Aeronautics Days, Madrid. 2012;30.
- [5] Eisenhut D, Moebs N, Windels E, Bergmann D, Geiß I, Reis R, et al. Aircraft requirements for sustainable regional aviation. Aerospace. 2021;8(3):61.
- [6] Affonso W, Gandolfi R, dos Reis RJN, da Silva CRI, Rodio N, Kipouros T, et al. Thermal Management challenges for HEA–FUTPRINT 50. In: IOP Conference Series: Materials Science and Engineering. vol. 1024. IOP Publishing; 2021. p. 012075.
- [7] Chapman JW, Schnulo SL, Nitzsche MP. Development of a Thermal Management System for Electrified Aircraft. 2020:0545.
- [8] Akhesmeh S, Pourmahmoud N, Sedgi H. Numerical study of the temperature separation in the Ranque-Hilsch vortex tube. American Journal of Engineering and Applied Sciences. 2008;1(3).
- [9] Gandolfi R, Ribeiro L, Oliveira J, Paiva K, Mantelli M. Passive Heat Exchange System for Aircraft Equipment Cooling Applications. SAE Technical Paper; 2015.
- [10] Pang L, Dang X, Cheng J. Study on heat transfer performance of skin heat exchanger. Experimental Heat Transfer. 2015;28(4):317–327.
- [11] Oliveira J, Tecchio C, Paiva K, Mantelli M, Gandolfi R, Ribeiro L. Passive aircraft cooling systems for variable thermal conditions. Applied Thermal Engineering. 2015;79:88–97.
- [12] Oliveira J, Tecchio C, Paiva K, Mantelli M, Gandolfi R, Ribeiro L. In-flight testing of loop thermosyphons for aircraft cooling. Applied Thermal Engineering. 2016;98:144–156.
- [13] Tecchio C, Oliveira J, Paiva K, Mantelli M, Gandolfi R, Ribeiro L. Thermal performance of thermosyphons in series connected by thermal plugs. Experimental Thermal and Fluid Science. 2017;88:409–422.
- [14] Gupta P, Khapli R, Huliraj R. Designing of Vapour Cycle Cooling System of Twin Seater Basic Trainer Aircraft. In: 2019 International Conference on Cutting-edge Technologies in Engineering (ICoN-CuTE). IEEE; 2019. p. 16–21.
- [15] Mezaal N, Osintsev K, Zhirgalova T. Review of magnetic refrigeration system as alternative to conventional refrigeration system. In: IOP Conference Series: Earth and Environmental Science. vol. 87. IOP Publishing; 2017. p. 032024.
- [16] O’hayre R, Cha SW, Colella W, Prinz FB. Fuel Cell Fundamentals. John Wiley & Sons; 2016.
- [17] Larminie J, Dicks A. Fuel Cell Systems Explained, 2nd ed. John Wiley & Sons; 2003.
- [18] Lukaczyk TW, Wendorff AD, Colonno M, Economon TD, Alonso JJ, Orra TH, et al. SUAVE: an open-source environment for multi-fidelity conceptual vehicle design. In: 16th AIAA/ISSMO Multidisciplinary Analysis and Optimization Conference; 2015. p. 3087.

## Acknowledgments

Authors would like to thank the institutions Embraer, Cranfield University, State Research Institute of Aviation Systems (GosNIIAS) and Moscow Aviation Institute (MAI) for the opportunity. The research leading to these results has been performed in the frame of the FUTPRINT50 project. This project has received funding from the European Union’s Horizon 2020 research and innovation programme under grant agreement No 875551.