

2006

# Establishing a New Paradigm in Engineering and Technology education: An Experimental Analysis of Multiple Learning Methodologies and Examination of Cognitive Profiles of Continuing Education Students

James A. Sinclair

Nova Southeastern University, [ittc63@verizon.net](mailto:ittc63@verizon.net)

This document is a product of extensive research conducted at the Nova Southeastern University [College of Engineering and Computing](#). For more information on research and degree programs at the NSU College of Engineering and Computing, please click [here](#).

Follow this and additional works at: [http://nsuworks.nova.edu/gscis\\_etd](http://nsuworks.nova.edu/gscis_etd)

 Part of the [Computer Sciences Commons](#)

## Share Feedback About This Item

---

### NSUWorks Citation

James A. Sinclair. 2006. *Establishing a New Paradigm in Engineering and Technology education: An Experimental Analysis of Multiple Learning Methodologies and Examination of Cognitive Profiles of Continuing Education Students*. Doctoral dissertation. Nova Southeastern University. Retrieved from NSUWorks, Graduate School of Computer and Information Sciences. (843)  
[http://nsuworks.nova.edu/gscis\\_etd/843](http://nsuworks.nova.edu/gscis_etd/843).

This Dissertation is brought to you by the College of Engineering and Computing at NSUWorks. It has been accepted for inclusion in CEC Theses and Dissertations by an authorized administrator of NSUWorks. For more information, please contact [nsuworks@nova.edu](mailto:nsuworks@nova.edu).

Establishing a New Paradigm in Engineering and Technology Education: An  
Experimental Analysis of Multiple Learning Methodologies and Examination  
of Cognitive Profiles of Continuing Education Students

by

James A. Sinclair

A Dissertation submitted in fulfillment of the requirements  
for the degree of Doctor of Philosophy

Graduate School of Computer and Information Sciences  
Nova Southeastern University

2006

An Abstract of a Dissertation Submitted to Nova Southeastern University  
in Fulfillment of the Requirements for the Degree of Doctor of Philosophy

## Establishing a New Paradigm in Engineering and Technology Education: An Experimental Analysis of Multiple Learning Methodologies and Examination of Cognitive Profiles of Continuing Education Students

By  
James A. Sinclair

April 2006

This study consisted of two inter-related components. The first part compared three instructional methods for delivering a Computer Aided Design (CAD) course for adult Continuing Education (CE) students. The second part established a comprehensive cognitive profile matrix of adult continuing education students entering careers in technology. The first part examined the use of three delivery methods, using three randomly selected groups of students. The three methods were as following:

- Traditional classroom-based training.
- Instructor-facilitated course presented online.
- Independent study, using a CD-ROM tutorial.

The experimental design consisted of three randomly selected sample groups of 20 students. The independent variable in the study was the instructional method. The dependent variables were the academic achievement scores and the satisfaction levels of the participants.

As a second component, the study determined a cognitive profile of adult continuing education students. This analysis involved the same group of 60 students and presented a quantitative matrix of learning styles (by way of the bi-polar cognitive profile matrix. After obtaining all of the statistical data, a correlation analysis was performed, comparing cognitive profiles students versus the instructional methodology.

The academic achievement analysis yielded the following results:

- There was a significant difference between in-class and online course, where in-class method showed higher academic achievement results.
- There was a significant difference between online course and the CD-ROM-based course. In this case the CD method was more effective then the online method.
- There was no statistically significant difference between the in-class and the independent CD-ROM methods.

The correlation analysis established that no significant correlation existed between the achievement and learning styles of the students. The results indicated that overall academic achievement within the subject of CAD are equal for all cognitive profile categories, allowing people with different learning styles to achieve their desired levels of academic success, as well as to meet their educational goals.

The results of the Objective Course Satisfaction and indicated that there was no significant difference among the three groups. It was, therefore concluded that the objective course satisfaction was equal among the three methods of instruction described in this study.



## Acknowledgments

I would like to express my gratitude to the members of the Dissertation committee, Dr. Marilyn K. Littman and Dr. John J. Sladicka, and especially to the committee chairperson, Dr. Maxine Cohen, for providing a great deal of mentoring during the long and arduous dissertation process. The assistance and support they gave so willingly during this difficult process, was an immense help for which I am truly grateful.

I also want to acknowledge the contribution of the team of dedicated professors at Kean University. Dr. Marvin Sarapin, Dr. Timothy Riegler, and Dr. Kupis provided much support, academic advice, and understanding that made significant contribution to make this complex work possible.

I would especially like to convey my sincere appreciation to my wife Alla, my parents, and my son David, for patiently enduring all of the difficulties of teenage life while seeing his father completing his educational process. Most of all, I would like to dedicate this work to my Mother-in-law Rita for offering her knowledge, wisdom and loving care, while pursuing all my academic endeavors for over twenty years. Also my Father-in-law Nukhim Myaskovsky, who unfortunately is not with us today to share my accomplishments, but who still lives in my heart, and offers his guidance to my entire family by the exemplary life that he had lived.

# Table of Contents

**Abstract** ii  
**List of Tables** viii  
**List of Figures** ix

## Chapters

### 1. Introduction 1

Introduction 1  
Background of the Study 5  
Cognitive Profile Inventory 7  
Multiple Methodology Models 11  
Theoretical Framework 12  
The Human-Computer Interaction Factor 12  
Problem Statement and Goal of the Study 15  
Relevance and Significance 17  
Barriers and Issues 18  
Purpose of Study and Research Questions 19  
Research Hypotheses 20  
Limitations of the Study 21  
Delimitations of the Study 21  
Definition of Terms 22  
Summary and the Organization of the Remainder of the Study 25

### 2. Review of Literature 27

Introduction 27  
Section One: Educational Styles and Cognitive Profiles of Adult Learners 27  
Section Two: Distance-learning Environments 32  
Section Three: Computer-based Instruction Methodologies 39  
Section Four: Combining Multiple Learning Methodologies 43  
Section Five: Learning Engineering Graphics and Design 46  
Section Six: Objective Student Satisfaction Philosophies 49  
Summary 52

### **3. Methodology 54**

Introduction	54
Hypotheses	54
The Population of the Study	55
Approach Employed	57
Instrumentation	59
Statistical Analysis	65
Cognitive Profile Inventory	66
Instrument Provider	66
Instrument Validity Data	66
Objective Student Satisfaction	66
Instrument Provider	67
Instrument Validity Data	67
Inter-Rater Reliability	67
Reporting of Data	67
Independent Variables	67
Statistical Data Provided	68
Academic Achievement	69
Resources	69
Summary	70

### **4. Results 72**

Purpose and Specific Aims	72
Description of the Sample and Demographics	74
Descriptive Statistics of the Population Sample	75
Statistical Analysis of the Experiment	76
Section 1: Academic Achievement Results	77
Descriptive Statistics Results	77
Achievement Statistics Results: Analysis of Variance Calculations	81
Academic Achievement Statistics Result Summary	82
Section 2: Student Evaluation of Instruction	82
Satisfaction Statistics Results: Analysis of Variance Calculations	86
Section 3: Cognitive Profile Data Results	87
Correlation Analysis Results	91
Summary of Findings and Analysis of the Hypotheses	95

<b>5. Conclusion, Implications, Recommendations, and Summary</b>	<b>98</b>
Conclusion	98
Implications	103
Recommendations for Future Research	105
Summary of the Study	107

## **Appendixes**

<b>A. Academic Achievement Examination</b>	<b>109</b>
<b>B. Objective Student Satisfaction Inventory Form E</b>	<b>185</b>
<b>C. Section Test Modules</b>	<b>186</b>
<b>D. Rating Forms</b>	<b>188</b>
<b>E. Cognitive Profile Data (Pilot Study)</b>	<b>191</b>
<b>F. Student Evaluation of Instruction (Pilot Study)</b>	<b>200</b>
<b>G. Student Academic Achievement Results (Pilot Study)</b>	<b>207</b>
<b>H. Complete Pilot Study Published Report</b>	<b>211</b>
<b>I. Cognitive Profile Inventory (Complete)</b>	<b>220</b>
<b>J. Satisfaction Evaluation Forms</b>	<b>225</b>
<b>K. Online Autocad Tutorial</b>	<b>236</b>
<b>L. Autodesk Learning Assistant CD-ROM</b>	<b>239</b>
<b>M. Solicitation Letter to Participating Companies</b>	<b>247</b>
<b>N. Content Validity Data</b>	<b>248</b>

<b>Reference List</b>	<b>249</b>
-----------------------	------------

## List of Tables

### Tables

1. Actual Grades Table 77
2. Achievement Statistics Summary 81
3. Achievement Statistics Analysis of Variance 81
4. Achievement Statistics Post-hoc t-Test 82
5. Student Evaluation of Instruction (*for all groups*) 83
6. Student Satisfaction Summary Table 86
7. Student Satisfaction Analysis of Variance 86
8. Student Satisfaction Post-hoc t-Test 86
9. Cognitive Profile Data 87
10. Cognitive Profile Percentage Data 90
11. Correlation Analysis Data 92

## List of Figures

### Figures

1. The cognitive profile inventory matrix 8
2. An example of four quadrilateral figures, depicting possible four different outcomes of individual students' cognitive profiles 10
3. Sample report form from the Office of Educational Assessment, University Of Washington 68
4. Group I Percentage Plot 79
5. Group II Percentage Plot 80
6. Group III Percentage Plot 80
7. Cognitive profile Plots 89
8. Correlations Point Plot 93
9. Correlation Analysis Results 94

## Chapter 1

### Introduction

*Adult learners are causing institutions of higher learning to re-think the focus of academic programs. The willingness of institutions to modify existing programs and develop new services geared to adult populations will have a positive impact on their ability to attract, serve, and satisfy the educational and career needs of adult students (Belanger & Strom, 1999).*

Within the past ten years, Computer Aided Design (CAD), representing a seemingly small aspect of modern technology, has been heavily integrated into a variety of technical disciplines. These disciplines, among others are: Architecture, Web Development, Interior Design, Landscaping, Drafting, Civil Design, Law (accident reconstruction, forensic analysis, etc.), Medicine, and all branches of Engineering (Pappas & Jerman, 2004; Steele, 2001; Volk & Holsey, 1997).

This study did not attempt to create an entirely new area of focus, but rather built on the foundation of existing evidence in multiple instruction delivery methodologies applied to adult education, and consequently, made a contribution to the science of technology education, CAD, and andragogy. The results of this study may contribute to the creation of a new paradigm that is subject-group appropriate (i.e. adult students pursuing continuing education in technical fields) (Aragon, 2003; Bailey, 1996; Verplank & Kim, 1987; Zoeller, 2000).

The study compared three methods of instructional delivery to determine if the online and CD-ROM based training is as effective as the traditional classroom-based course. The experimental design consisted of three randomly selected sample groups. Each group was comprised of 20 adult CE students 30-50 years of age. The independent variable in the study was the instructional method. The dependent variables were the academic achievement scores and the satisfaction levels of the participants. Of the three groups of adult Continuing Education students, Group 1 had received the traditional classroom training (control group), Group 2 received an online course (treatment group 1), and Group 3 was trained independently, using a CD-ROM-based course (treatment group 2). Data was gathered regarding the achievement scores and participant satisfaction levels of all three groups. Upon completion of the course, two specific assessment instruments were administered to all of the participants. These statistically validated instruments were used to measure the differences in learning achievement (test scores) and course satisfaction of all participating students.

The groups were randomly selected from the pool of registered Continuing Education students at Kean University, Union NJ. For the purpose of this study, these students had completed the Cognitive Profile Inventory to determine a cross-sectional profile of learning styles. The groups were comprised of students who seek to enter (or to expand) a career related to, or directly in, the discipline of Computer Aided Design.

Each of the three groups of students (one control, and two treatment groups) was required to complete a 32 Hr. (8 week) CAD course presented in one of three instructional delivery methods:



a. Method I (*Control Group*)

The students had completed all of the prescribed course content using traditional classroom training, with the professor presenting the prescribed material and being available to help students in person at any time during the course. At the end of the course, students were required to complete a Student Satisfaction Inventory (IAS-Form E) (OES-UW, 2002), as well as complete the 75-question Autocad Achievement Examination (see Appendix A) (Kalameja, 2000).

b. Method II (*Treatment Group I*)

All of the prescribed material was learned off-campus, and was facilitated by the professor via an asynchronous, Internet-based course. In this component, the students were required to communicate with the instructor on a daily basis (Monday-Friday) to receive new information and complete the required material within agreed time frames. The communication was conducted via the Internet-based communication forum, specifically dedicated to the study. At the end of the course, students were required to complete a Student Satisfaction Inventory (IAS-Form E) (OES-UW, 2002), as well as complete the 75-question Autocad Achievement Examination (see Appendix A).

c. Method III (*Treatment Group II*)

All of the curriculum material was learned by independent study using a well-

recognized Autodesk-certified instructional tutorial on a CD-ROM. At the end of the course, students were required to complete a Student Satisfaction Inventory (IAS-Form E) (OES-UW, 2002), as well as complete the 75-question Autocad Achievement Examination (see Appendix A).

In addition to utilizing commercially available testing instruments (i.e. Cognitive Profile Inventory and Student Satisfaction Survey), the author had prepared a special achievement assessment test, referred to in the preceding section. The 75-question Autocad Achievement Examination is specifically focused on the material presented during the study. Although the developed test resembles the Standard AutoCAD Certified Assessment Examination, the modified material had undergone a complete validation process, including content validity by a carefully selected panel of experts, as well as statistical validation during the pilot stage (see Appendix N). This enabled the researcher to generate a highly precise and much more finely tuned statistical academic achievement measurement. An independently approved criterion was established to assure measurable and conclusive results (Gay & Airasian, 2000). For the purpose of testing the research hypotheses (see Chapter 3), all acquired data was subject to statistical analysis, using appropriate statistical tests and procedures, thus providing assurance of reliable, and indisputable interpretation.

## **Background of the Study**

*Computer Aided Design (CAD), which for more than 15 years has enabled engineers to create and modify products using on-screen computer graphics, has been recognized as one of the greatest engineering achievements of the 20<sup>th</sup> century by the American Society of Mechanical Engineers (Torre, 2000).*

Technology and engineering are important elements of modern society. Especially in the U.S., where technological developments of the last century have significantly contributed to shaping the industrial development of the entire world. The continued economic viability in the U.S. is one of the contributing factors of maintaining peace and prosperity worldwide (Torre, 2000). Technology enthusiasts are at the heart of the development of a better and safer world. Unfortunately, due to various factors, factors that stem from the very foundation of the technological process, the number of such enthusiasts in this country is diminishing (Corry & O'Quinn, 2002; Sigmund & Fletcher, 2000). One of the key reasons for this trend is the inability, or to be more direct, unwillingness on the part of many traditional educators to adopt and implement new tools and technologies to enhance the learning process (Kauchak, Eggen, & Burbank, 2005). This in part is due to a lack of understanding as to how modern computer integrated technology improves learning, comprehension and, as a result, may lead to higher retention and increased motivation in student populations (Provenzo, Brett & McCloskey, 1999; Ratcliff, Johnson, & Gaff, 2004; Rowe, 1997; Zoeller, 2000).

Due to the increasing popularity of computers in the modern workplace, a variety of new professions have developed in areas that in the past had been strictly the domain of

manual labor and skilled craftsmanship. One such area of technology discussed in this study is Computer Aided Design (CAD), which was distilled from manual architectural / mechanical drafting, both of which were used to graphically represent engineering thoughts and ideas. The increasing affordability of computers and design software programs has resulted in the growth of manufacturing and design companies that are interested in implementing CAD technology (Odem & Griffin, 1999; Torre, 2000). Computer Aided Design has arisen as a distinct field of technology; a field that has become a unifying factor in integrating the disciplines of computer graphics, human factors, industrial and applied engineering, computer science, and robotics.

Many techniques in this field date from Sutherland's Sketchpad thesis (1963) that essentially marked the beginning of computer graphics / CAD modeling as a discipline. Work in computer graphics has continued to develop. Algorithms and hardware allow the display and manipulation of increasingly more realistic-looking and more complex objects (e.g., CAD machine components, medical images of body parts, etc.). Although CAD systems have been in existence since the early 1960's, their wide integration into a common workplace did not begin before the early 1980's. Until that time these systems, due to their enormous price tag, could only be purchased by the largest corporations, such as Boeing, General Motors, McDonald Douglas, etc. (Rowe, 1997; Zoeller, 2000).

Due to the nature and difficulty of the subject matter in most branches of computer-aided design, and the varied backgrounds of students entering continuing education courses, many engineering and technology instructors are seeking methods of instruction that would enhance learning, and therefore, improve the overall achievement outcome of students (Burlison, Ganz & Harris, 2001; Debourgh, 1998; Enockson, 1997).

The goal of this research was to help improve the traditional educational process by analyzing effectiveness of multiple educational models pertinent to one specific technical discipline common to all areas of modern engineering and technology – Computer Aided Design.

Two distinct aspects of modern adult engineering and technology education were encompassed by this research:

1. *Cognitive Profile of the Students.*

Using existing, statistically validated instruments, a comprehensive cognitive profile matrix of adult continuing education students entering careers in technology was established, as well as the identification of their personal style of thinking, learning, and decision making (Briggs & Myers, 1991; Hess, Zachar & Kramer, 2001; Jung, 1990; Krause, 2000).

2. *Experimental Design Analysis of the Three Educational Models.*

The study, by an experimental design, compared educational models, consisting of three learning methods.

### **Cognitive Profile Inventory**

Whenever any educational model is being designed or analyzed, it is of vital importance for researchers to understand the cognitive profile of the population under investigation. “Everybody learns differently from everyone else” (Krause, 2000).

Different subject disciplines may affect people in a different way. Some students may be more perceptive when learning music and some may be more efficient in engineering or mathematics. The cognitive profile inventory proposed for this study is a variation model

of Dr. Jung's, and Myers & Briggs theory. The Cognitive Profile Inventory (CPI), currently available at Clemson University (Krause, 2000) is based on the theoretical concept that all learners may be divided into the two major categories of Intuitive or Sensor learners (bi-polar opposites). These categories would then be further divided into four segments, and plotted on a special quadrant-type chart (See Figure 1).

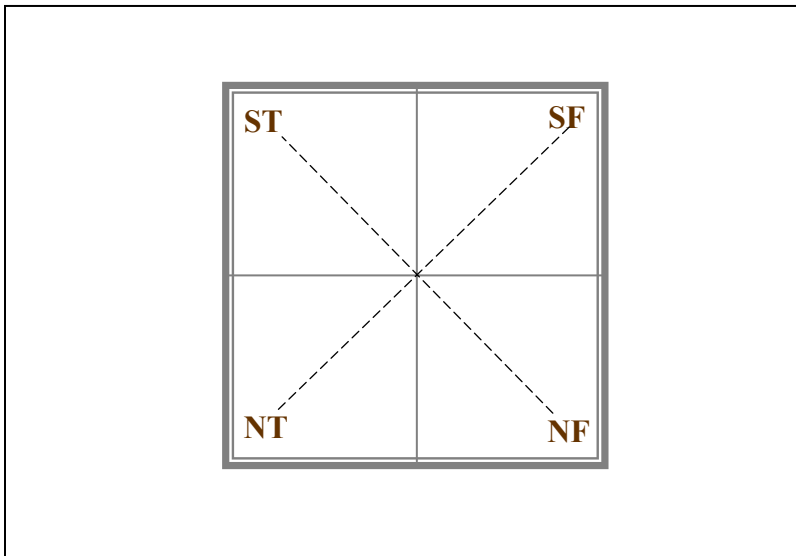

**Figure 1.** The cognitive profile inventory matrix

Below is a brief description of the four learner types and is quoted, in part, from Dr. Krause's publication (Krause, 2000):

1. ***Sensor-Thinker*** (further specified as **ST**).

“The Sensor-Thinker category usually applies to types of students who are analytical learners who work in an organized fashion, methodically and stepwise. They learn best alone, and by repetitious drill and practice“ (p.24).

2. *Sensor-Feeler* (further specified as **SF**)

“Sensor-Feeler applies to types of students who are concrete learners, but who are better suited for cooperative learning. They often process information verbally and learn best when they relate personally to the content“ (p.25).

3. *Intuitive-Thinker* (further specified as **NT**)

“The Intuitive-Thinker is characterized by logical thinking, perception of patterns and a strong need to understand. An intuitive thinker needs to mentally process new material alone before discussion and must see the overall picture prior to processing details to build understanding” (p.26).

4. *Intuitive-Feeler* (further specified as **NF**)

“Intuitive-Feeler types are characterized by being creative learners. They usually have a strong dislike for routine work, organization, and memorization. They are usually more abstract, doing creative things in fine arts and music” (p.27).

The Cognitive Profile Inventory consists of 60 pairs of questions. Prior to the experiment, all of the study participants have completed the inventory. The quantitative results thus obtained will be graphically and numerically plotted for each student (see Figure 2).

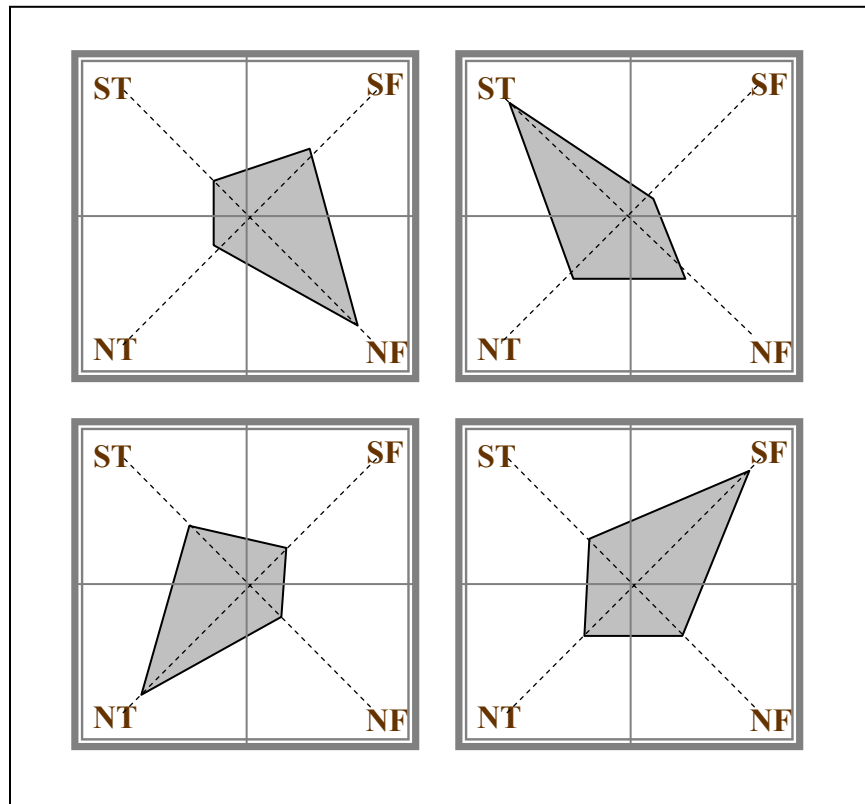

**Figure 2.** An example of four quadrilateral figures, depicting possible four different outcomes of individual students' cognitive profiles.

After all of the data was analyzed, an individual general cognitive profile was established for each participant. It should be noted that the cognitive profile results determined the learning styles of the adult students entering technology program. This now offers valuable information to the researcher as to the type of the population being studied. The cognitive profile matrix offers a clear statistical picture of the studied student population. In addition, since the completion of the multiple-methodology experiment, the researcher has performed a comprehensive correlation analysis,



comparing the individual cognitive profiles to the achievement results, as well as course satisfaction.

### *Multiple Methodology Models*

In the early 1990's, Lewis Perelman examined and conducted numerous experiments involving five learning modules applied to a variety of disciplines (Perelman, 1992). The five delivery methods were as following:

1. Lecture (traditional in-class method)
2. Tutorial teaching (instructor facilitated, online-based)
3. Tutorial teaching (self directed, video, CD-ROM, etc.)
4. Group recollection (applying portion of information in small groups)
5. Student teach back (students teach portion of learned material to the rest of the class)

Although all of the five methodology models have a measure of effectiveness, for a more specific focus defining a scope of this study, only the first three modules have been selected. Additionally, the reason Computer Aided Design (CAD) discipline has been chosen for this work is its unifying factor, transcending all branches of modern engineering and technology sciences (e.g. mechanical, electrical, architectural, nuclear, medical, etc.). Thus, the results of this study may affect a large majority of technical students. The researcher anticipates that this study may open new avenues and possibilities, allowing a broader range of educational opportunities.

## **Theoretical Framework**

The major theoretical framework of the study has been based upon the existing body of evidence encompassing the following aspects:

1. Body of research that examines educational styles and cognitive profiles of adult learners, entering technology careers (Bailey, 1996; Briggs & Meyers, 1991; Jung, 1990; Krause, 2000; Zachar & Kramer, 2001; Payne, 2002).
2. Body of evidence related to computer-based and web-based instruction in technology, architecture, engineering, and graphics design (Barr & Juricic, 1998; Burleson, Ganz, & Harris, 2001; Florman, 1997; Leong, Ho, & Saromines-Ganne, 2002; Torre, 2000).
3. Research related to multiple educational models that involves traditional and computer-based learning methods (Knowels, Holton, & Swanson, 2005; Larson & Keiper, 2002; Perelman, 1992; Winkleman, 1999)
4. Comprehensive analysis of possible “gaps” in the above-mentioned body of research, as well as further study recommendations, to analyze the applicability of existing work to the specific student group and the subject of Computer-Aided Design.

## **The Human-Computer Interaction Factor**

When people learn any subject without the physical presence of the instructor, an interface that delivers the material and contributes to a better understanding of the subject is extremely important. For example, a book is an interface. Many modern computer books, in order to simulate the best, traditionally established learning method –

apprenticeship (i.e. replicating the instructor), incorporate computer-screen images called “screen shots” photographically displayed on the pages of the book.

For most beginners, the higher fidelity these screen shots are (color, look, feel, etc.), the better they would consider the book to be. In reality, all learners are looking for the “perfect” interface that will teach them the material with the least amount of effort (on their part). Of course, all learners have every right to feel that way. Less effort means more satisfaction, and more satisfaction may lead to a better comprehension of the subject, which in turn leads to a higher degree of overall success (Scuito, 2002). Realistically, however, there can never be a “perfect” interface, because everyone defines “perfect” differently. However, certain similar components, leading to better comprehension, could be established, developed, and integrated into computer-related educational products (Boone, Jones, & Safrit, 2002; Hewett et. al, 1997; Thurmond, Wambach, Connors, & Frey, 2002).

In the early days of computers, interfaces were much less appealing than they are today. Relatively expensive, and offering very little visual appeal and intuitiveness, computers in general were not popular. Only a small percentage of select professionals needed, or were able to afford a computer at home. In engineering applications, although early CAD systems did offer some degree of graphics in its interface, it was not yet “friendly” or appealing enough for people to seek a career related to it (especially in areas related to manufacturing, where all of the graphics programming had to be performed directly on the metal-cutting machines). In more recent times, however, as a result of much friendlier and appealing environments used in CAD/CAM technology, leading to a much easier comprehension and faster learning curve, a much larger number of adult

students are becoming interested in careers related to these disciplines, as well as a number of related fields (e.g., computer animation, medical simulation, etc.). Of course, a more appealing environment is only one of the aspects of this phenomenon. One of the most important aspects is that CAD had created an intermediate layer of professions between engineers and much less educated specialists (e.g. machinists, drafting, and clerical employees). In the past, engineers and architects were among the very few people who could properly visualize and interpret three-dimensional objects by analyzing complex two-dimensional drawings and plans. This ability was developed as a result of highly specialized educational and professional training programs. A typical adult person, interested in pursuing a career in any engineering-related field, would have to complete such an educational program including several advanced disciplines such as Calculus, Differential Equations, Vector Mechanics, and College-level Physics, etc. This difficult challenge has limited the number of individuals able to complete their education and to pursue a career in these fields (Pappas & Jerman, 2004).

Based on the researcher's classroom experience with the continuing education students, a much "friendlier" (i.e. easier to comprehend without mathematical / technical knowledge) computer environment is one of the leading reasons why individuals who have no technical background or who do not fall within the traditional engineering groups consider a career in many areas of modern technology, such as: Robotics, Interior Design, 2 and 3-dimensional modeling/design, Architectural and Mechanical Rendering, Animation, etc. These developments have opened many exciting career opportunities for thousands of people, who would otherwise never be able to consider such careers.

### **Problem Statement and Goal of the Study**

The major goals of this experimental study was to establish a cognitive profile matrix of adult Continuing Education students, as well as to develop, document, and explore the results of an adult CE CAD course taught by employing a three-group educational model to identify feasibility and applicability in comparison to the traditionally used methodology in a variety of outcome measures. In summation, the problem that was investigated is whether alternate instructional methods in CAD, is in fact, an effective alternative to the traditional classroom methodology, and to which extent adult student population may mostly benefit from it.

Although the growth of online and computer-based training programs has been significant in recent years, and the future growth potential within higher and continuing education remains virtually limitless in terms of the opportunities for both the institutions and the learners, the capabilities and efficacy of such programs have yet to be fully investigated. An extensive amount of effort in this area has been devoted mostly to program development and most systematic examinations of program quality and effectiveness have been anecdotal in nature. With little empirical knowledge about computer-based education outcomes and processes, related to the discipline of Computer Aided Design, the need for research in this area is not only timely, but also imperative. In most of the private sector, training within the engineering/technology community has significantly expanded over the last two decades, and is now considered one of the most important aspects of the profession. This may involve learning entirely new computer programs, or, in many instances, increasing one's skills or obtaining re-certification in specific disciplines. Most of the modern technical professionals rely more increasingly on

proper and thorough training in order to perform their jobs effectively. As technical skill demands of most modern industries have increased over the years, so have the demands on individual professionals and companies to provide adequate training. In addition, with the advent of many new federal/local regulations and specific requirements (e.g. personal and environmental safety, new military standards, clean-room equipment regulations, etc.), many companies are required to implement the mandatory training. This can become a burden for most companies and individuals not only financially, but most importantly, time consuming. Many technical professionals have to take time from work or in the evening hours taking continuing education courses to simply cope with the changes in technology and, in many cases, learn new skills in order to continue maintaining their jobs (AST, 1999; Kenschak, 2002).

Before the introduction of computer technologies, traditional classroom setting was accepted as a norm, one that until recently was unavoidable. Today, using the modern computer technology and the immense capabilities of the Internet, many students, as well as corporations, are exploring alternative learning methodologies. As technology continues to develop and the increasing number of people are getting involved in an off-campus style of learning, questions as to its effectiveness and applicability have arisen (Pachnowsky & Jurczyk, 2003). Professionals in all walks of life need assurance that traditional classroom-based certification courses can be successfully adapted into computer/Internet training settings. When training courses are implemented in a corporate environment, the administrators are becoming increasingly concerned with the time required to conduct the actual training, the skills obtained as a result, and the

overall participant satisfaction of the training. Many corporations are now willing to explore possible alternatives to the traditional format (Beard & Harper, 2002).

### **Relevance and Significance**

*Multimedia systems have emerged as one of the fastest growing segments of computing systems and thus need to be well integrated into computer-related and engineering curricula.*

(Burleson, Ganz, & Harris, 2001).

Research in education has shown that learning is enhanced when the learning environment is made less restrictive or more compatible with every day life situations (Belanger & Strom, 1999; Florman, 1997). Quite a bit of learning occurs outside the confines of the classroom. Therefore, educators might consider being less restrictive in their teaching methods. The computer is a teaching aid and gradually it is becoming an integral part of the educational environment. Many educators have yet to realize the usefulness of the computer in stimulating student interest, and thus forming positive learning behavior patterns (Barr & Juricic, 1998; Aragon, Johnson, Palma-Rivas, & Shaik, 2000).

One of the major goals of this researcher, is that this study might serve as a model to assist college-level instructors of technology, architecture, and engineering with the development and utilization of relevant materials related to computer assisted instruction methodology for undergraduate, graduate, and continuing education students. Although much prior scientific work has dealt with some aspects of this research in a variety of disciplines (Perelman, 1992; Pistillo, 1996; Winkleman, 1999), the proposed study has investigated certain areas of adult education that have not yet been thoroughly explored.

This research uniquely studies adult learners who wish to pursue training in professions that require knowledge of Computer Aided Design, employing a variety of traditional and innovative educational methodologies. The findings of the proposed study may have a direct effect on improvements in the development and integration of computer-based / online education.

### **Barriers and Issues**

Economic factors form significant barriers in modern technology (Ratcliff, Johnson, & Gaff, 2004; West, 1998). During the constant economic shifts, many educational, as well as corporate organizations are simply not willing to invest in new research. Some companies, mostly automotive and pharmaceutical giants, would gladly invest their money in new equipment – not new ideas (Knoles, Holton, & Swanson, 2005; Ghee, 1999).

In the past, buying computer equipment, as well as the software capable of supporting Computer Aided Design, due to extremely high cost, was one of the major barriers for many schools. Since the early 1990's, in most cases this barrier is no longer an issue. Qualified instructors, however, are still difficult to find. Most hands-on specialists of CAD are engineers and draftspersons from industry, not possessing sufficient academic background to qualify for most university-level teaching positions. One of the possible advantages of the proposed methodology is to allow existing instructors to conduct multiple classes at any given time, and not be restricted, at least in part, by time zones and geographic boundaries (Driscoll & Carliner, 2005).



Although a variety of multiple instructional methodologies have been successfully implemented in a small number of American institutions, and within a limited list of disciplines (Ertmer & Newby, 1996; Jeffries, 2000; Mesher, 1999; Pistillo 1996; Tinto, 1997; UWA, 2000; Winkleman, 1999), the reason it has not been explored further is due to the general lack of educational enthusiasts in the areas of engineering and especially in the disciplines related to Computer Aided Design, who are willing to change existing paths into a more innovative paradigms. This, as well as other related factors, has created a certain gap in the technological advancements of our time (Arbaugh, 2000; Hai, 1997; Park & Seidel, 1989). The author, having an extensive academic and professional background in engineering, computer integration, and adult education, feels confident that this study may have a significant educational and practical impact on technology and engineering in the 21<sup>st</sup> century paradigm.

### **Purpose of Study and Research Questions**

The purpose of the proposed study was to measure the academic achievement and overall course satisfaction differences of adult students, according to their individual ability levels, when taught by three methods of instruction.

More specifically, the study has investigated and attempted to answer the following research questions:

1. Were there any significant differences in objective course satisfaction, among the three methods used, among adult Continuing Education students learning Computer Aided Design?

2. Were there any significant differences in academic achievement, among the three methods used, among adult Continuing Education students learning Computer Aided Design?
3. Did a correlation exist (and to which extent) between the cognitive profiles of the students, course satisfaction, and academic achievement results among adult Continuing Education population learning Computer Aided Design?

### **Research Hypotheses**

In addition to numerous examples observed by the researcher and based on preliminary investigation of the relevant literature, the following research hypotheses are presented below in a null format:

- H<sub>01</sub>:** There will be no significant difference in objective course satisfaction among the three methods of instruction among adult Continuing Education students learning Computer Aided Design.
- H<sub>02</sub>:** There will be no significant difference in academic achievement among the three methods of instruction among adult Continuing Education students learning Computer Aided Design.
- H<sub>03</sub>:** There will be no correlation between the cognitive profiles of the students, course satisfaction, and academic achievement results among adult Continuing Education population learning Computer Aided Design?

### **Limitations of the Study**

This study has been limited to students pursuing a career directly in or closely associated with the discipline of Computer Aided Design (CAD). The student population has been randomly selected from the two sources: first, registered Continuing Education students at Kean University; second, students drawn from the local New Jersey manufacturing, design, and architectural companies. Therefore, the study was limited to the population group located primarily in Northern New Jersey. A total of sixty students participated in the study. All three groups are heterogeneous, representing a mixture of diversified range of knowledge and professional experience levels, as well as a wide range of academic achievement and behavioral characteristics.

Additionally, the subject groups represented a mixture of ethnic backgrounds, as well as a cross-section of nationalities. In past experiences observed by the author, the ethnic background of the CE students studying CAD was as following: 60% of the students are Caucasian (having approximately 30% of the students from Eastern Europe, i.e. Poland, Russia, Romania, Yugoslavia, etc.), 25% are Hispanic, and the remaining 15% are African-American.

### **Delimitations of the Study**

1. Only adult students (ages 25-50) participated in the study.
2. Only those familiar with general drafting and design practices and standards were included in the study.

3. The educational level of the participating students was a minimum of a High School diploma or equivalency and did not exceed that of a Bachelor Degree level.
4. Only students pursuing a Continuing Education Certification, as oppose to the undergraduate or graduate levels, were included in the study.

### **Definition of Terms**

#### *Computer Aided Design (CAD)*

CAD is a representative of several computer software programs, used by architects, engineers, drafters, artists, and others to create precision drawings or technical illustrations. CAD software can be used to create two-dimensional (2-D) drawings or three-dimensional (3-D) models (Techtarget, 2003).

#### *Computer-based training (CBT, Computer Assisted Training)*

Computer-based training as a method of delivering training material through a personal computer without the need for a live facilitator (Lawson, 1999).

#### *Effective means of delivery (Effectiveness)*

For the purpose of this study, effectiveness has been determined through an evaluation of participants' academic achievement (test) scores, and satisfaction levels, presented in numerical format for each of the three participating groups (i.e. depicting the three separate methodologies used in this study).

### *Hyper learning*

One of the relatively modern educational methodologies, where multiple modes of instruction are presented within the duration of the same course/semester.

Additionally, the term Hyperlearning is sometimes used to depict any type of learning that is different from traditional learning methods (e.g. computer-based, video/audio-based, etc.) (Perelman, 1992).

### *Multimedia based training.*

This form of training involves the delivery of educational materials “using the combination of text, sound, pictures, animation, and video”. (Microsoft Corp, 2001)

### *The Sensor Learners (Bi-polar Descriptors).*

The sensor learners are concrete learners. They prefer to learn through the senses; by touch, sight, sound, taste, and smell. They want to pick things up, turn them around, and see all sides. The sensor learners, the ST and SF, work most comfortably with concrete (unambiguous) information. Sensor learners prefer details first, the way our schools generally teach, building to the concept through the details, step by step (Krause, 2000).

### *The Intuitive Learners (Bi-polar Descriptors).*

The intuitive learners prefer to take information in an abstract form, as ideas, images, or concepts. From the initial concept, they will develop a conceptual framework or structure, into which they can fit the details later. The intuitive learners, NT and NF,

work most effectively in the abstract, and need to begin new material with a global perspective. This direction is foreign for most educators. The intuitive learner will generally be assisted by reading the material prior to class in order to glimpse the whole concept (Krause, 2000).

*Traditional, classroom-based training.*

This type of training consists of training in a physical setting where the students are physically present and receive instruction from a live facilitator.

*Two-Dimensional (2-D) Design.*

The creation, display, and manipulation of objects on the computer in two dimensions. Two-Dimensional (2-D) CAD programs allow objects to be drawn on an X-Y scale as if they were drawn on paper (TechEncyclopedia, 2003).

*Three-Dimensional Design (3-D).*

The creation, display and manipulation of objects in the computer in three dimensions. Three-dimensional (3-D) CAD and graphics programs allow objects to be created on an X-Y-Z scale (width, height, depth). As 3-D entities, they can be rotated and viewed from all angles as well as be scaled larger or smaller. They also allow lighting to be applied automatically in the rendering stage (TechEncyclopedia, 2003).

### *Solid Modeling.*

A mathematical or computer-aided design technique for the representation of solid objects. Unlike wire frame and surface modeling, solid modeling systems ensure that all surfaces meet properly and that the object is geometrically correct. Solid models allow for interference checking, which tests seeing if two or more objects occupy the same space. Solid modeling is the most complicated of the CAD technologies, because it simulates an object internally and externally. Solid models can be sectioned (cut open) to reveal their internal features, and they can be stress tested as if they were physical entities in the real world (TechEncyclopedia, 2003).

### **Summary and the Organization of the Remainder of the Study**

This research study has been organized into five chapters. Chapter 1 has served to describe the background, relevance and significance of the problem to be investigated. It has offered a brief description of the relevant research questions and hypotheses that will be focused upon. Additionally this chapter has given a summary of the characteristics of the subject population, limitations, assumptions, and delimitations pertaining to this study.

Chapter 2 contains a review of the literature, relevant to the issues under investigation, and is separated into several sections examining the following: research related to the educational styles and cognitive profiles of adult learners; distance-learning environments; research related to computer-based instruction methodologies; literature analysis of the Hyperlearning philosophies (i.e. the combination of methodologies incorporated into one educational model); specific area of education related to the

learning of engineering graphics and design; and the last section, is dedicated to the examination of objective student satisfaction philosophies, relevant to the subject of distance education and adult learning. Chapter 3 contains a detailed design of the study including methodology, data collection and analysis techniques, treatment variables, instrumentation, and statistical analysis to be utilized in the study. Chapter 4 presents information on the results of the study analyses. It includes a description of the population sample, followed by descriptive statistics on key variables. Lastly, each section begins with a restatement of a specific aim and is followed by the results of analyses. And Chapter 5 includes a study conclusion, implications, recommendations for future research directions, as well as the summary of the study.



## Chapter 2

### Review of Literature

#### Introduction

Three distinct areas of concern in the field of adult continuing education converge to make the current study one of important significance: educational styles and cognitive profiles of adult learners, Web-based instructional environment methodologies, and the independent educational process, involving a variety of computer-based learning methods. This review of literature investigates these areas of concern, first as individual domains of educational research, and then as they have been used in settings where the approaches have been combined.

This review is divided into six sections: The first section examines research related to the educational styles and cognitive profiles of adult learners. The second section examines distance-learning environments. The third section delves into research related to computer-based instruction methodologies. The fourth section describes the literature analysis of the Hyperlearning philosophies (i.e. the combination of methodologies incorporated into one educational model). Section five sheds some light on the specific area of education related to the learning of engineering graphics and design. The last section of this review is dedicated to the examination of objective student satisfaction philosophies, relevant to the subject of distance education and adult learning.

#### *Section One: Educational styles and cognitive profiles of adult learners*

Although many educational methodologies have been devised over the years, it is remarkable that traditional techniques are so effective, and are a testament to the intuition

and observation of educators throughout the ages. While traditional educational methodologies should never be discarded, there will always be room for improvement through a variety of alternate adult learning philosophies (Aldrich, 2005; Caffarella, 2001; Cranton, 2001; Davis, 1997; Jensen, 1998).

The use of the web for adult education has led to many questions that demand answers (Roblier, 2004). These questions are varied, and seek to justify or not, web-based (i.e. non-classroom, external) education. Abbey (2000) points out that such topics as; instructional design principles, cognitive strategies, human-Internet interaction, and instructional characteristics have come to the forefront in the design process that accompany every web based education initiative. He presents the new Web based education paradigm from several points of view. These points of view are presented through a number of independently written articles individually separated by categories. Overall, his work provided a welcomed glimpse of Web Based Training from a cognitive point of view, while at the same time reminding the educator that web based presentation of material is an evolutionary and not revolutionary step in the education process (Abbey, 2000; Bastiaens & Martens, 2000).

Kenny (2002) and Jensen (1998) maintain that new cognitive approaches can be especially useful when dealing with non-traditional students and non-traditional learning, which is exactly the situation produced in the distance-learning environment. In Kenny's case, however, the research was limited to nursing education only. Distance learning, however, presents additional challenges. In most instances, it cannot exactly reproduce the environment of the classroom, given the limitations of current technology (computer power, network bandwidth, etc.). Therefore, it is necessary to examine the process of

learning scientifically, in order to determine what exactly is needed for learning to be accomplished successfully (Arbaugh, 2000; Krause, 2004; Lasley, 1997; Pascarella, 2001; Pittinsky, 2002).

Furthermore, Jensen (1998) defines the process of learning as a physical and chemical process. This approach utilizes song, hand eye coordination, repetition, and physical performance, to enhance the learning process. While some might not embrace this approach to learning, a comprehensive understanding of what goes on in the brain when one recites, recalls, and speaks, can prove invaluable when transitioning the traditional chalk and blackboard classroom into the 21<sup>st</sup> century (Abramov & Martkovich, 2002; Galbraith, 2003).

Belanger and Strom (1999), as well as Bender et.al. (2004) further discuss teaching techniques, specifically focused on the adult learners. When attempting to improve education through the use of non-traditional methods, it is sometimes helpful to examine the educational backgrounds of non-traditional students or student groups. The education of these groups presents several obstacles that bear a strong resemblance to the obstacles presented when trying to implement non-traditional education methods such as distance learning. This is especially true when dealing with scenarios that include the education of many adult learners (Abbey, 2000; Belanger & Strom, 1999). Belanger and Strom (1999) deal with literacy education of adult learners, especially those in the University setting. By drawing from surrounding life and work experience, comfort and motivation can be encouraged in the adult student, a student who might otherwise feel uncomfortable in an academic environment. Much of the academic experience of Belanger and Strom deals with literacy education of learners across disciplines, that is,

with varied academic backgrounds. Thus, it has much in common with CAD education, a subject discipline that attracts students from the ranks of manual laborers to the ranks of engineers. Their point of view is especially pertinent to those considering non-traditional learning methodologies and the use of non-traditional mediums for delivery, due to its emphasis on technique rather than delivery method. The lessons learned by those seeking to promote and enhance adult literacy form a valuable lesson for those preparing nontraditional educational methodologies (Allen, Bouhris, Burell & Mabry, 2002; Poonwassie and Poonwassie, 2001; Salmon, 2000; Wilson and Hayes, 2000).

Caffarella (2001) points out that the education of adult learners has long been an underemphasized segment of the educational paradigm. This segment of the education consuming population is becoming more numerous and important, partially due to demographics and the realities of economics, but due to the new educational opportunities that have been made available to the adult learner. The author (Caffarella), having a strong background in the field of adult education, and having conducted much research with similar focus, includes in her exhaustive research every aspect of creating, maintaining and expanding an adult education program. She draws upon both classic and current educational literature and provides much practical advice garnered through years of experience. Although it is difficult to predict the long-term outcomes of multiple methodologies within the different disciplines and when applied specifically to adult students, she strongly underlines the importance of interactive models for program planning, and includes valuable overview or framework of planning and setting up an adult education programs, both in-class and within the distance learning environments. (Caffarella, 2001) Many texts have been devoted to the development of instructional

curriculum for education. However, far fewer have been specifically devoted to adult education, and the techniques uniquely applicable to the adult education environment. Cranton (2001) deals with many important subjects in the area of the adult education field. She expands upon original concepts, utilizing new thinking drawn from educational research as well as lessons that have been learned in the industry. She has done extensive research in the areas of measurement, evaluation, and computer applications in adult education, as well as research in faculty development, and multimedia-style adult learning. When it comes to adult distance education, she points out its applicability to both university and industry-level instructions. In this case, generality is not a weakness. It provides a solid basis for planning instruction based on how adults learn. She identifies learning characteristics that can impact instruction. Also, Cranton outlines unique insights into how to approach writing with the adult learner. In her research, she provides different approaches to learning styles as well as an analysis of different andragogical techniques (Cranton, 2001).

Krause (2004) suggests that one way to improve student educational outcomes is through the adjustment of student study and learning habits. In her research "*How We Learn and Why We Don't*", the author has developed and statistically validated a comprehensive cognitive profile matrix, which provides a clear identification of students' personal style of thinking, learning, and decision-making. Dr. Jung's psychological model describes differences in how people assimilate information and make decisions. The Cognitive Profile Model has been used to identify subjects according to the Jungian theory. The model has proved successful in study after study, including those that have included statistically significant groups of students. The author (Krause) have prepared a

simple-to-follow manual that helps to identify and generally classify students by learning profile categories, and then propose appropriate study habits for individual, as well as groups of students. “Educators have found this manual useful when designing new curricula, and especially useful when designing new educational methodologies, since this method has been proven to improve outcomes and new flexible educational methodologies (such as Hyperlearning) can only exploit it further” (Krause, 2004).

*Section Two: Distance-learning environments*

For various reasons, Computer-based training is increasingly being used, even for mainstream and so called “Traditional” Instruction. Computer-based training can take on a variety of forms, depending on need and desire. Certainly, autonomous computer-based drill and testing is still the most common type of training (Aldrich, 2005). The advent of high capacity storage CD-ROM media has made very complex computer-based multimedia presentations possible. Now, the almost universal access to the Internet has made real time or almost real time distance learning a reality. These three approaches can be viewed as only three of a variety of delivery alternatives, some incorporating more traditional elements as well. Lee and Owens (2000) have provided an extensive resource, shedding much light on the development and implementation of multimedia based and thus computer-based instructional design. Their research examines the types of media available, and outlines the media dependent advantages and disadvantages. Most importantly, the overall commonality of all media is demonstrated. The overall focus is the development of instructional content that is medium independent yet can take advantage of different delivery systems. This approach is a great time saver, since the

instructional content can be developed first and any or all delivery and presentation methods presented later, a significant time and money savings. Throughout their research, the professional academic approach can be seen, indicating that there are in fact significant differences in the over-all academic achievement, satisfaction, retention, etc. exist, therefore encouraging further analysis in the variety of disciplines, both, technical and liberal. The procedure that is used for multimedia-based content is analytical and methodical. First, there is assessment and analysis. Where the analysis phase determines the best approach based on demographics, environmental situations, needs of the consumer, and limitations of technology. Of course, the mental limitations and practical limitations of the target audience are addressed. The multimedia instructional design phase encourages the development of a course design specification. Development and implementation presents the common elements of development and the unique elements of computer-based, web based distance broadcast and other solutions (Arsham, 2002). Multimedia evaluation, presents the all-important testing and evaluation technologies available using the multimedia-based solution. Whatever the design need, this text will present those who are developing computer-based educational presentations with a particular academic approach to curriculum development (Lee & Owens, 2000).

The advent of the Internet as an educational tool enables educators to extend the classroom beyond classroom hours, and even provide us with a virtual classroom. This interest in the Internet on the part of educators has created a surge in academic texts and tools geared specifically for the academic market (Rothwell, Butler, Maldonado, Hunt, Peters, & Li, 2006). Moore, Winograd, and Lange (2001) have provided significant research that is uniquely useful in that, it discusses the actual technique of teaching

online. The Internet as a teaching tool is discussed both at the technical level and at a level needed for practical development. All material necessary for assessment, course development, and class delivery is provided, along with numerous case study examples. Evaluation techniques are suggested that will bring about significant improvement in course materials, format, and schedule. The authors (Moore, et. al) first, make a case for online learning featuring its advantages and the issues surrounding it, based on a number of outcomes, practical, and financial justifications. Second, they cover the actual development of an online environment, the tools used, commercial, and public domain course delivery platforms, translation of teaching style to the online environment, course content translation, and the actual technology of transfer of educational materials (text, pictures, audio, films) to an online environment. Finally, they discuss issues concerning implementation and evaluation of courseware, conducting an actual class including feedback, encouraging discussion, reflection, and other techniques. The authors maintain that the evaluation section is most important, since a course must be repeatedly compared with its traditional counterpart. Various benchmarks, measurement strategies, and techniques are also presented. Suggestions for improvements in courseware and course management are suggested, based on results of these benchmarks. Although showing mixed results, the authors share a view, based on their extensive research that educational delivery differences (or similarities) should definitely be further analyzed and explored in an ever-increasing variety of subjects, as well as a variety of population groups (Moore, Winograd, & Lange, 2001).

Between instructors and students alike, there exist a variety of opinions about computer-based education capabilities, which are largely positive and optimistic (Relan



& Gillani, 1997; Simonson, Smaldino, Abright, & Zvasek, 2005). However, there are many challenges that are associated with creating an evocative and productive distance-learning environment, designed specifically for adult learners, whether it is CD-ROM or Internet based (Aragon, Johnson, Palma-Rivas, & Shaik, 2000; Hill, 1997; Roblyer, 2004).

One of the challenges is having the ability to meet the expectations and satisfy the needs of both the teacher and the student. Another challenge is how the instructors will design computer-based courses so that they provide a rewarding and effective learning environment. From the perspective of the program developer and the instructor, a thorough understanding of these issues is essential for the development and implementation of quality online instruction (Banathy, 1994; Belanger, 2000; Brandt, 1996; Relan & Gillani, 1997; Webster & Hackey, 1997).

Bellanger (2000) maintains that while traditional classroom education involves educator controlled delivery of material in the same geographic locale and in fact in exactly the same room as the learner, several variants of this presentation method have developed over the years. These variants were thought to be compromises; inferior but convenient. The most common variant is distance education through traditional mail based correspondence. This methodology is convenient for persons not willing or able, for a variety of reasons, to attend an educational institution “in person”. This method involves the shipment (via mail) of course material to a distant locale, inhabited by the student, who will then diligently apply him or herself to the material. Homework, projects of various sorts, and exams are then mailed back to the correspondence education school for evaluation and grading. Distance education has evolved from this humble beginning

by utilizing modern computer and telecommunications technology. It has none of the shortcomings of correspondence education, while enjoying all of the benefits. Through the use of the computer and some form of electronic communication, much of the immediacy, spontaneity, familiarity, and even peer communication present in traditional educational methodology can be retained. This can be done while delivering education to a widely dispersed geographic body. Distance learning offers the individual student as well as the sponsoring institution many benefits, including travel time saved, cost reduction, less time away from the job, etc. While there are no limitations on what material can be represented through the distance-learning format, course material must be specially prepared for effective use by the methodology. Belanger further presents techniques, processes, and tools that can be used to construct a distance-learning project. Also, more importantly to the traditional instructor, he provides a series of techniques to determine to what degree a course is amenable to conversion for distance learning delivery. Furthermore, he provides much valuable information on the subject of preparing curriculum, converting traditional curriculum to distance learning formats, as well as accessing the curriculum in an abstract theoretical context. Finally, through the use of widely accepted technologies, a number of educational scenarios are presented, scenarios that explore the rich and diverse nature of the many approaches that can be taken with this medium. It provides a framework for successfully implementing a distance learning project and the techniques to accurately compare it with traditional educational techniques so as to evaluate its place within the educational methodology paradigm (Belanger, 2000).

Long before the advent of the World Wide Web as a medium, distance learning was seen as one solution to equal access, as well as cost and time effective use of learning resources (Ilabaca, 2000). The objective of any effort to improve distance learning is to make the experience of the distance learner as complete as that of the traditionally educated student (Simonson, Smaldino, Albright, & Zvacek, 2002). Therefore, the experience does not have to be the same, but rather equivalent in terms of outcome and satisfaction (Morris, 2002). Simonson, et al. further demonstrates that it is the goal of any distance-learning project to satisfy this criterion, whether the project uses computer, video or audio only techniques. The goal is independent of the technology used. Of course, computer and Web- based distance education provides a whole series of opportunities. The problems, however, remain the same. The authors provide design and implementation techniques that seem like common sense, but should be stated anyway, especially when dealing with a new technology where one can become obsessed with using all of the “bells and whistles”. An important topic remains - the evaluation of the effectiveness of online learning. In fact, how best to evaluate learning is a significant question. The authors further address the issue of using newer and more complex instructional models (Moore, Winograd, & Lang, 2001).

The concept of Distance Learning has taken a large leap forward with the advent of the Internet (Roblyer, 2004). Now, Internet connectivity can bring multimedia based two-way communication to virtually any desktop in the civilized world. In order to best take advantage of this new medium; an attempt must be made to leverage its strengths while compensating for its weaknesses. One of its chief weaknesses is the lack of direct face-to-face contact between instructor and student. Aldrich (2005) and Mesher (1999)

demonstrate that interactivity is the key to online learning. Having extensive experience with online learning via his web-based course in critical thinking, he presents a valuable research work appropriately titled “Mission: Critical”. Through this experience, Mesher has developed a methodology that produces courseware that is appropriate for the web. A standard course is not merely transferred to the Internet based medium but instead; using higher levels of interactivity are used to enhance the course content. This type of approach motivates students and provides a pathway for the synthesis of new information with prior knowledge. These factors are important keys to education, whatever the employed medium. Traditional interaction takes the form of communication between learner and instructor or learner and learner. The simplest form of interaction is a form of learner to content interaction, where material is presented in some form, followed by presentation of recall questions. Interactivity, however, requires the student to reflect on and synthesize the information that they have acquired (Anderson, Banks, & Leary, 2002; Aragon, Johnson, Palma-Rivas, & Shaik; McCabe, 1997; Mesher, 1999)

Internet-based instruction has the capability of providing efficient, low cost, and convenient education. In addition, it harbors the potential of enhancing learning through the use of computer-based tools and asynchronous capabilities (Berge, 2002; Chen, 2002). A group of scientists at the University of Illinois have done a small, but rather comprehensive study by comparing two graduate courses (Aragon, Johnson, Palma-Rivas, & Shaik, 2000). Much effort was put into selecting the proper performance and attitude based measuring instruments. Measurement of distance learning parameters was performed by the DOLES (Distance and Open Learning Scale), as well as the Dimensions of Distance Education (DDE). A great emphasis was placed on the study of

student satisfaction of various aspects of both online, as well as face-to-face education. While other studies generally measure outcome through subject skill based testing and final grades, this study included a final project produced by individual or groups of students from both the online and “face to face” populations. An impartial three-judge panel independently evaluated this project. Thus, a further measure of performance can be compared. Overall, skills based performance for both groups were similar, however a disparity in favor of “face to face “ instruction was found in overall objective student satisfaction. This disparity was based mostly on a lack of student-instructor and student-student based interaction. The conclusion was drawn that online-based instruction holds much promise but efforts must be made to facilitate student-instructor and student-student based interaction (Hirumi, 2002).

### *Section Three: Computer-based Instruction Methodologies*

Any computer-based training, especially some forms of computer-based distance-learning, needs to rely upon multimedia for communication. A multimedia system can be defined as a system that delivers heterogeneous content from a source to the end user while maintaining some form of synchronization between the content types. Burleson et. al. (2001) based at the University of Massachusetts, have come up with a remarkable idea, that is: Why not study multimedia technology by teaching multimedia technology, using multimedia. A courseware development package was produced that was easily able to accomplish this task. Since the courseware was developed in house, it is as customizable and extensible as it should be, as part of a broad test of the viability of this type of technology. The system is unique in allowing homework and answers to questions

to be issued in multimedia format. Demonstrations coded in the form of Java applets or CGI scripts can be run interactively as needed. An online testing system is of particular interest, since it allows the student to request review questions in various difficulty levels and even to “test out” of the module by demonstrating subject mastery. Modules can be used as quick introductions to extensive subjects when extensive knowledge of these subjects is not required. This reduces the need for library research or unnecessary prerequisites. Collaboration on class assigned design projects is facilitated via a multimedia-rich whiteboard, a system that allows group viewing and manipulation of material. Finally, a library of standardized projects developed especially for group collaboration, allows and reinforces real world design experience while providing a tested and predictable outcome instrument that can be used for comparison. The system developed by the University of Massachusetts can be held as an example of customization of a computer-based learning multimedia system for a particular need and vision (Burleson, Ganz, & Harris, 2001).

There have been a number of experimental research studies relating the effectiveness of computer-based instruction methods to the more traditional, face-to-face classroom setting, and have provided hopeful results for creators of online instructional courses. In 1997, Schutte conducted an experiment in which he separated a class of randomly selected adult students, between a traditional classroom section and a virtual section taught on the Internet. Although his study was imperfect due to a lack of control over the amount of student interaction and teaching methods his results demonstrated that instruction provided online can result in improved performance (Hanna, Glowaski-Dudka, & Conceicao-Runlee, 2000; Schutte, 1997).

In 1998, LaRose, Gregg, and Eastin conducted a similar study, which compared the learning effects of adult students in a traditional lecture setting, to the performance of students who participated in a course setting that utilized pre-recorded audio sessions via the Internet, along with detailed course outlines and Web pages related to the course. Results showed that the group that learned on the Internet had equal test scores and student attitude ratings to those of the traditional section. Although these types of quasi-experimental studies present methodological challenges (e.g., dealing with small sample sizes, the effect of prior knowledge, etc.), they do provide an important foundation upon which a better understanding of the effect of online instruction on learning effects and student satisfaction shall be built (Desberg & Fisher, 2000; LaRose, et. al, 1998).

Many educators believe the Internet to be the focal point of a major shift in the way students learn (Arbaugh, 2000). The Web has been described as a panacea for a number of problems, from lack of motivation among students to a way to bring education to the millions who cannot afford a first rate education in their home communities (Abramov & Martkovich, 2002). Certainly, Internet technology can address these problems, however, although it has much potential, it is not about to sweep away current educational methodology. Ilabaca (2000), a leading educator at the University of Chile, after having performed an exhaustive analysis of the technology at hand, brings some reasonableness to the discussion by pointing out prior communication technologies that were described as about to begin a revolution in the educational system. One such was the motion picture; a technology that even Thomas Edison predicted would replace textbooks in education. Ilabaca further demonstrates the difficulties that arise when introducing technology into the educational system. It is suggested that Internet

technology should be introduced slowly into the existing classroom by first replacing traditional forms of multimedia such as projectors and audio devices. Then, it should also be used as a research reference much as a personal library, available to every student. It is emphasized that each step in the introduction of technology should be justified as helping to achieve a pedagogical objective. The author places great emphasis on analysis of student behavior when presented with an Internet access device. Much of the resulting behavior is seen as wasteful and non-educational, behavior such as random browsing of web sites, performing searches without specific objectives, etc., which just consumes time without leading to comprehension of any particular subject matter. The professor's attitude towards technology is also a major factor in how the computer is utilized and viewed. In addition, Professors who are occasional users of the technology do not readily appreciate its value. Educators who utilize educational technology for everything from Internet technology to banking, tended to have a better appreciation of its power and more optimism for its use in education (Arsham, 2002). In addition, the placement of computers for the specific use of Internet access plays a role in how the net is utilized by the class. Computer labs, set aside for exclusive computer use, are used rarely and wastefully. Whereas a computer enabled classroom under the control of a professor who directs a lesson by using web access to Internet sites appropriate for a particular educational goal is presented as a very effective educational method. The utilization of the Web as a method of providing a form of distance learning was heralded as a possible major contribution to education. This recognition was tempered by the realization that a particular appropriate educational methodology must be developed, specifically to exploit this medium. In addition, the possibility of many Internet-enabled classrooms creating a



large virtual classroom capable of collaborative learning across many nations and across cultures was seen as an ultimate goal of internet-based education. The information provided in Ilabaca's research provides further corroboration of findings produced within the U.S. The same thinking from educators around the world seems to suggest the same thing. That is, for the Internet to become a major factor in education, educational methodology will have to be adjusted to make use of the Web's strengths while tempering its weaknesses, such as its tendency to provide too much unfocused information and act as a distraction to real learning. The most important point brought forth here as elsewhere, is that traditional educational methodology should not be entirely abandoned, but rather strengthened through the use of computer technology in general and the Internet in particular (Ilabaca, 2000)

*Section Four: The Hyperlearning philosophy (combining multiple learning methodologies).*

Over the years, many scholarly experts have proposed ways of improving the educational system, both at the pre-college and college level. Most improvements have centered on improving productivity, although recently, cost control and quality have become motivating factors (Ertmer & Newby, 1996; Perelman, 1992; Simonson, Smaldino, Albright, & Zvacek, 2002). The impetus behind this desire for improvement is understandable, since the traditional methodology of education has not changed much in the past 200 years. One of the reasons that it has not changed is due to the relationship between student and instructor, with the student seen in an employee role as the subordinate of the instructor. Some have looked at the consumer model and the customer-

supplier relationship, and have seen a more natural functional system at work (Palloff, 2001). The author of *Hyperlearning* (Perelman, 1992) proposes this model (i.e. customer-supplier) as the centerpiece of a multimedia and communication based education network that will provide education to all students, whether traditional or nontraditional, in just the correct quantity, at the correct time. He feels that the present system places schooling and learning at odds, with the present schooling system being justified by tradition alone and propped up by a system of myths that can be summed up with the saying: “People learn best in school” (Aragon, 2003; Perelman, 1992; Pistillo, 1996).

It is remarkable that Dr. Perelman’s book “*School’s out*” (1992) was first released just before the advent of the World Wide Web. The Web would make a system of self-tailored, multimedia based education, very convenient and efficient. A significant point made, is that the learning model should not be static, but that a multi-faceted approach should be taken. People learn using many different modalities, with some justifiable learning taking place using the traditional educator-student format. While traditional methodology should not be abandoned completely, given the economy of the 21<sup>st</sup> century and the new technological tools at the disposal of educators, education is due for a profound change (Burlison, Ganz, & Harris, 2001; Desberg & Fisher, 2000).

One of the most important benefits of education is the development of a student’s ability to learn. That is, not only the development of the abilities in a specific subject matter should be developed, but also learning skills that can be carried throughout life and used for a variety of different types of material. This process is complicated by the requirements of different educational material. Depending on the type of educational material under scrutiny, a slightly different approach is required to efficiently achieve

educational objectives. In addition, different types of students learn in different ways. Ertmer and Newby (1996) attempt to bridge the gap between learning effort and accomplishment by developing a model for a prototype expert learner. The expert learner relies on reflection and analysis of the learning process as it is occurring or immediately after it occurs. The expert learners must understand themselves as learners, or they must be evaluated for learning style (Galbraith, 2003). The learner must then develop a learning strategy that depends on the type of learner that they are and the type of material that they are attempting to master. The expert learner must also analyze the requirements of each task and develop an optimum learning strategy that relies on these factors. This strategy, when implemented, must be continuously modified while in use and the results analyzed for a later modification of the strategy. Thus, a sort of mental feedback loop must be employed, one that utilizes reflective thinking to continuously regulate the learning process. Any attempt to develop or improve educational methodology must take the concept of expert learning into consideration. First, any educational methodology must develop in its students, the ability to reflect on their own learning process, and make adjustments to make the learning process more efficient. Second, the educator must understand students as learners and continuously evaluate their progress. The result of this evaluation should result in adjustments in instructional approach that will increase learning performance. In essence, the instructor should do on a “macroscopic scale”, what the student should be doing on a “microscopic” scale. Thus, an understanding of cognitive processes, and the use of motivational, and environmental strategies, will assist both students and educators to yield optimum educational outcomes as well as a satisfactory learning experience (Ertmer & Newby, 1996).

*Section Five: Learning Engineering Graphics and Design*

All engineers and technologists use computer graphics at some point to communicate their ideas, whether it be through a rough sketch on the back of a napkin, or a detailed document drawn to specifications using all standard engineering conventions. The advent of computer graphics has changed the way designs are produced, but not the need and desire to communicate ideas (Aragon, 2003; Henderson, 1999). That is the driving force behind all graphics and design. Henderson's observations reveal many real world habits and behaviors on the part of technologists, such as the mixed use of paper and computer-based graphics; the tendency to sketch out informal ideas on paper and copying preprinted material to paper for later revision and discussion. Visual representation has the ability to combine many diverse levels of knowledge, so that the same graphic information can be interpreted and filtered differently by different people depending on the task they must perform in the design process. Visual representation is even used, as a tool, by non-design people in proposing ideas to management or selling ideas to prospective customers (Henderson, 1999).

As to a comparison of the use of CAD and hand drawing, it is observed that some technical organizations use both, and that regardless of the sales hype of CAD software companies, both methodologies (i.e. computerized and manual) are still needed. The difference between the two types of communication methodologies is significant, possessing different rules and requiring different skills, despite the fact that in the end, needing to accomplish the same thing - the communication of technical ideas. The reflection on the use of new computer-based tools and conventions makes Henderson's

ideas (1999) of visual representation and communications most useful. Although CAD systems have been around for approximately 25 years, designers and engineers, worldwide, are still exploring their full capabilities and potentials (Kauchak, Eggen, & Burbank, 2005). A true understanding of the role that graphical communication plays in conveying technical ideas can help to rectify this weakness. This understanding is especially important to the educator, who must convey computer-based graphics concepts to both, those who are new to the field of technical illustration, as well as those who are used to doing things using the more traditional paper and pencil method. The advance of new technology is making some skills obsolete while placing renewed emphasis on others. The advent of computer aided simulation is making engineering design and testing much more efficient. Computer-based simulation requires that component geometry be accurately entered into a CAD program. Therefore, efficient CAD skills have become ever more important to the general technological skill base. Ghee (1998), describes the use of various types of simulation in industry and its importance for all future Engineering Endeavor. Ghee is the director of engineering at division in Bristol, England, which has U.S. operations in San Mateo, California. Interactive product simulation (IPS) complements the processes used to create three-dimensional geometry. Whereas CAD software is typically designed for non-real-time modeling, IPS is a real-time visualization and interaction system. CAD/ID/CAE/CAM geometry is exported to IPS software, which comprises two core components: large-scale assembly visualization and navigation, and the ability to simulate a product's functionality or behavior. This technology provides significant returns during the entire product life cycle, enabling designers, engineers, customers, and others not only to visualize and navigate design

geometry but also to interact with the functional characteristics of a prospective product. IPS software leverages a company's investment in CAD design by providing earlier access to prototypes, faster updates than with physical models, enterprise wide distribution of information in an easy-to-understand format, support for existing processes, and long-term value that extends beyond the finalization of product designs. This type of software has been integrated into system infrastructures to create visual databases of CAD/ID/CAE/CAM geometry, and is now available as a front-end graphical user interface for information held in product-data-management (PDM) systems. The software can be used to evaluate the ease of assembly of any geometry or part-location changes. This type of technology will enable firms to leverage existing components and part geometries more than ever. By being able to view and manipulate “off the shelf parts” (i.e. standard, interchangeable components), an engineering team can gain experience with it without the financial and time cost of actually acquiring a sample.

What is most noticeable is the degree of collaboration that is possible, on a particular design. Even designers based in areas that are geographically distant from each other can collaborate on design due to the Internet capabilities built into the software. This technology can have an impact on what people need to learn to be successful workers for the future but also in how people learn. A new level of virtual “Hands On” learning has now become possible. Collaboration can now become the norm, even for distance learners. All of this demands a new way of teaching, a new approach that will foster the lifelong learning that will be necessary to adapt to new technological approaches. Therefore, new educational approaches will not only be useful, but necessary

to foster the new skills required for future endeavor (Boone, Jones, & Safrit, 2002; Ghee, 1998).

### *Section Six: Objective Student Satisfaction Philosophies*

“Satisfaction relates to perceptions of being able to achieve success and feelings about the achieved outcomes” (Keller, 1983). From this viewpoint, several studies have investigated student satisfaction levels including computer-based and online-based programs (Andersen, Banks, & Leary, 2002; Debourgh, 1998; Enockson, 1997; Johanson, 1996; Lee & Owens, 2000; McCabe, 1997; Moore, Winograd, & Lang, 2001; Palloff, 2001). For example, in 1997, Enockson, conducted a study considering the effectiveness of distance education in a university setting. With this study, they found that students were more satisfied with online instruction because it provided flexibility and responsiveness to their learning necessities and expectations. In the same fashion, in 1996, Johanson concluded that based on her study of an online classroom, students’ satisfaction is positively impacted when one or more of the following four points occur:

1. The technology is understandable and functions both reliably and conveniently.
2. The course is specifically designed to support learner-centered instructional strategies.
3. The instructor’s role is that of a facilitator and coach.
4. There is a reasonable level of flexibility.

In contrast, in 1998, Debourgh found that student satisfaction depends more on the quality and effectiveness of the instructor and the instruction, rather than on the technology itself.

The facility of distance learning has become available rather suddenly. It developed from the same technology used by the World Wide Web. As such, it represents a rather specialized construct of a web based multimedia experience. Online education, however, is very different from other online web content (i.e. websites, web-based entertainment, etc.), and as such deserves special scrutiny and a significant amount of comprehensive research. Palloff and Pratt (2001), in their work titled “Cyberspace Classroom” attempts to explore the complete online education paradigm, from the point of view not primarily of technology, but rather from the point of view of educational technique, course satisfaction, appropriate presentation, and a thorough analysis of the psychology of the online student and educator. A thorough examination of the motivation of those who are using online coursework can highlight the strengths and weaknesses of the online system. Certain personalities either will consciously or intuitively find the online system superior, particularly those who are introspective in nature (Allen, Bouris, Burrell, & Mabry, 2002; Krause, 2004). Others will find the lack of spontaneity and feedback from the student body quite frustrating. Both groups, however, can benefit from interaction, even if it is asynchronous (via email, forums, etc.). All research and experience suggests that online learning is a special skill that needs to be developed in the student as well as in the educator. The educator’s role in the online skill development process is not simply a matter of mastering course content software, but using a new and novel approach to education. The irony is that the approach used in an online environment can also be utilized in a more traditional setting. Therefore, both online and traditional student populations can benefit. The student also must be trained to properly utilize the online learning environment, especially when using the asynchronous



approach. This approach requires a bit more discipline on the part of the student, so again the outcome is student specific, although affected greatly by pre-training.

Palloff and Pratt further maintain that the development of online content can best be developed gradually at first via supplements to traditional classes, review, lecture notes, course supplements and the like. Online computer-based education offers the opportunity to purchase pre-produced coursework, developed by others for general use. Here, special attention must be paid through the use of customization for teaching approach and supplementary information, so that the course becomes the instructors own, rather than a “canned lesson” with the instructor simply acting as an actor who is following preprogrammed instructions. Many times administrators and other well-meaning individuals are assigned the task of implementing an online learning environment on behalf of their institutions. They often consult with technology industry representatives who are understandably motivated by profit. That is, they attempt to reproduce the classroom experience and in fact surpass the classroom experience with lengthy audio and video clips, electronic white boards, etc. This approach, while impressive, is often unnecessary and can be burdensome to faculty members who are unprepared to present complex multimedia lessons as well as spend long hours in live chat sessions.

The presentation method should be developed with the advisement of faculty, who can view not only what is possible but also what is necessary. Research bears this out, revealing good results with a simple audiographic approach. Whatever the approach, gradual adoption is the answer, with significant input from faculty, as well as the students that the system will serve (Palloff & Pratt, 2001).

## Summary

The review of literature on cognitive profiles of adult learners, Web-based instructional environment methodologies, and the independent educational process, involving a variety of computer-based learning methods reveals two important aspects. First, the studies examining various learning variables in distance education and independent study provide support that the concept of alternative (i.e. out-of-classroom) educational methodologies is an important factor to be considered in modern educational models, servicing both, the traditional degree programs, as well as the Continuing Education populations. Second, the literature review addressed a variety of both positive and negative findings in the areas of adult education, especially in areas relevant to student course satisfaction as it relates to academic achievement outcomes. The reviewed studies helped in developing appropriate questions/ hypotheses for this research.

The literature reviewed also provided support that student satisfaction is an important outcome to assess in Web-based and independent study courses. However, caution should be taken regarding interpretation of the literature review because much research in distant education has not used a true experimental design, which allows scientists to make conclusive causal inferences. Some of the studies reviewed used a descriptive, exploratory design conducted in the natural (i.e. non-manipulated) environment. Some of the “gaps” encountered in the reviewed studies were as following:

1. Emphasis on student outcomes for total programs instead of individual courses.
2. Lack of consideration for learning styles of adult students based on the technology / methodology used.

3. Lack of research related to education methodologies in the areas of Computer Aided Design.
4. Almost a non-existent research related to examination of a correlation between the learning styles and academic achievement of adult, continuing education students in the areas of CAD.

## **Chapter 3**

### **Methodology**

#### **Introduction**

The purpose of this chapter is to:

1. Detail the hypotheses that were tested in the study
2. Describe the population that was employed in the study
3. Describe the approach employed
4. Describe the Instruments that were used to collect relevant data, including reliability and validity of the instruments used in the study
5. Describe formats for presenting results

#### **Hypotheses**

In addition to numerous examples observed by the researcher and based on an investigation of the relevant literature, the following three research hypotheses are presented below in a null format:

- H<sub>01</sub>:**            There is no significant difference in objective course satisfaction among the three methods of instruction among adult Continuing Education students learning Computer Aided Design.

**H<sub>02</sub>:** There is no significant difference in academic achievement among the three methods of instruction among adult Continuing Education students learning Computer Aided Design.

**H<sub>03</sub>:** There is no correlation between the cognitive profiles of the students, course satisfaction, and academic achievement results among adult Continuing Education population learning Computer Aided Design?

### **The population of the study**

Since Computer Aided Design is a broad-range discipline (i.e. used in almost all areas of modern design and technology), to truly analyze the tested results, one would have to choose from a broad range of population, representing a valid cross-section student sample. Although it is not feasible, within the scope of this study, to select an appropriate sample representing all possible professions using CAD in modern technology, certain major groups of technical population were distilled as a representative, relevant to this study. These groups are:

1. Lower-level education manufacturing personnel (e.g. machinists, welders, assemblers, stock-room attendants, etc.)
2. Higher-level education technical personnel (e.g. engineers, drafters, designers, project managers, etc.)
3. Lower-level education construction personnel (e.g. builders, roofers, masons, carpenters, etc.)

4. Higher-level education architectural personnel (e.g. architects, take-off designers, interior/exterior designers, general contractors etc.)
5. Miscellaneous profession and mixed education personnel (e.g. fashion designers, medical/pharmaceutical applications, jewelry designers, etc.)

The above students were drawn from the following sources:

1. Registered Continuing Education adult technology students at Kean University (mixed range of professions)
2. Representatives from the manufacturing / engineering industry
3. Representatives from the construction / architectural community

Upon the specifically obtained permission by the researcher from the Kean University administration, the entire experiment was conducted without any tuition cost to the students, both University students and industry representatives. This, in a way, assured a fairly large available sample population. The researcher has established numerous contacts at a large variety of New Jersey companies and professional associations who expressed interest and were willing to provide participating personnel. Among these companies were: Valcor Engineering Co. (Springfield, NJ); W.C. Kaupp Co. (Maplewood, NJ); Schering Plough Corp. (Union, NJ); BCANJ (Building Contractors Association of New Jersey); Cendant Architectural Group (Parsippany, NJ), as well as other small-to-midsize manufacturing and architectural firms located in Central and Northern New Jersey.

The representative students from the above sources covered a wide-range cross-section of the overall population, using, to a various degree, Computer Aided Design in their professions. To assure a more precise and un-biased results, the students were not told that they are participating in a specific study; they were told that they will be receiving qualified training at no cost, provided by the Kean University faculty. It is important to note here that the author of this dissertation, as a Director of Technology Continuing Education within the Nathan Weiss Graduate College at Kean University, is constantly pursuing new methods of outreach and support to New Jersey's manufacturing industry, as well as construction/ architectural community.

As described earlier in the study, there were three distinct groups of students participating in the treatment - a control group, and two treatment groups. From the pool of approximately 100 students, 60 were randomly selected and assigned to one of the three specific groups by the researcher. Students were assigned unique numbers that were used for correlation comparison and in all statistical analyses.

### **Approach**

The study investigated three groups of adult learners (ages 30 -50), participating in a Computer Aided Design course. Within this established age category, and upon successful completion of the course, an examination was given to investigate the differences in learning achievement (test scores), and a survey, to measure the course satisfaction levels.

The following steps were involved in completing the study:

1. Three groups of 20 students were randomly selected from the pool of 100 registered Continuing Education students and the representatives from the aforementioned industries. The entire student population was limited to students who seek to enter a career related to, or directly in, the discipline of Computer Aided Design.
2. All of the students in the three groups had completed a Cognitive Profile Inventory (Krause, 2004). Each cognitive profile inventory survey was marked with a distinct number for each participant. This number remained with each student throughout the entire duration of the experiment. Later, these unique numbers were matched to achievement and satisfaction scores, as well as the cognitive profile results.
3. The three groups were then introduced to a normally scheduled, certified continuing education course term of 8 weeks (32 Hrs.) and were trained in the following manner:

**Group I (*Control Group*)**

The students in this group completed all of the prescribed course content, using traditional methodology (classroom training, with the professor presenting the prescribed material and being available to help students in person). At the end of the course, students were required to complete a Student Satisfaction Inventory (IAS-Form E) (OES-UW, 2002), as well as completed the AutoCAD Achievement Examination (See Appendix A).



**Group II (*Treatment Group 1*)**

All of the prescribed material was learned off-campus, and was facilitated by the professor via an Internet-based course. During this segment the students were required to communicate with the instructor on a daily basis to receive new information and complete the required material. The communication was conducted via the established live, Internet-based communication forum, specifically dedicated to the proposed study. At the end of the course, students were required to complete a Student Satisfaction Inventory (IAS-Form E) (OES-UW, 2002), as well as completed the AutoCAD Achievement Examination (See Appendix A).

**Group III (*Treatment Group 2*)**

All of the curriculum material was learned via an independent study using a well-recognized AutoDesk-certified instructional tutorial on a CD-ROM. The Learning Assistant tutorial is created by the Autodesk Corporation – creator company of AutoCAD software. At the end of the course, students were required to complete a Student Satisfaction Inventory (IAS-Form E) (OES-UW, 2002), as well as completed the AutoCAD Achievement Examination (See Appendix A).

**Instrumentation**

New educational methodologies must be legitimized through careful evaluation. Both qualitative and quantitative variables must be measured, recorded and then compared with norms that have been documented for the particular parameter in question. The questions must be validated, by measuring their structure for correct

interpretation and all ambiguity must be removed. Finally, the questions must be validated in the setting where they will be used (Gay & Airasian, 2000).

As per convention, if a measuring instrument is constructed from a pool of validated questions, it still must be validated as a reliable measuring instrument. The extra time, effort, and expense of validation, as well as the danger of unintentionally introducing error into the sampling process, must be weighed against using a measuring instrument that is not an exact match for the educational environment within the study. A poor fit will yield poor or irrelevant results. However, a validated measuring instrument that is not an exact fit can still be utilized, provided that the mismatch occurs in one or two questions that can be discarded after data collection. That is, the student will be allowed to complete the validated assessment using standard form. Subsequent data collection will then simply disregard the inapplicable or invalid questions. In this way the validity of the testing instrument will still remain sound (Levy & Lemeshow, 1999)

While no measuring instrument may completely match the educational situation under study, the questions that are asked should be as close as is possible. When the criteria for usefulness were determined, a search was begun for a qualified measuring instrument. Many instruments were examined. To assess objective student satisfaction, an assessment system created and validated by the University of Washington was chosen, partially due to the availability of a number of pre-validated forms that are slight variants of one another. This allows choice by closest fit. The assessment system is the Instructional Assessment System (IAS) (Gillmore, 1998; OES-UW, 2002). It is described as a system used to summarize student ratings of instruction at the post-

secondary level. It is one of the oldest student rating systems in the nation, and used at many institutions of higher learning.

When given a pre-validated assessment instrument, appropriateness cannot be matched exactly. A compromise must be made that yields appropriate data, while at the same time having the instrument, have as much impact on the outcome of the assessment as possible. The forms themselves vary in content, depending on the type of course and instructional strategy that is utilized in the course. When the forms are described, it will immediately become obvious that several of them are less appropriate for the course type in this study (i.e. for an adult continuing education Computer Aided Design course).

Form A was designed for lecture/discussion courses that possess some interaction between instructor and student. Form B was designed for large lecture classes with little or no in class interaction. Form C was designed for seminar discussion classes that include a minimal amount of lecture. Form D was designed for classes that teach problem solving or heuristic methods. Form E was designed for skill oriented classes. This particular form (Form E) was intended for those classes that are skill oriented and where “hands on” experience is emphasized. This description fits the type of course under study, so this form will be closely examined. Form F was designed for quiz sections. Form G was used for large lecture classes that rely heavily on homework problems and textbook reading. Form H was used for lab classes taught in conjunction with lecture classes in the physical sciences. Form I was designed for distance learning courses. Again, there are many similarities with the situation under study; however, both the in-class and distance-learning section must use identical measuring instruments. Form J was

designed to evaluate instruction provided through clinical experience rather than coursework. Form X was designed as a general form to assess educational outcomes.

From their general descriptions, it should be obvious that most forms are inappropriate. However, to be sure, as well as to distinguish between forms that are relatively appropriate for the course under study, it was decided to use a form rating system. Examination of the forms leads to two conclusions. First, each form can be rated for appropriateness or inappropriateness by rating the appropriateness of each question in the form. The forms as used in the study, have measured course methodology effectiveness. Most of the forms tended to put slightly too much emphasis on instructor's performance. For example, a question that attempted to measure instructor performance was "Instructors ability to deal with student difficulties was:" It would be advantageous to minimize the number of questions that attempt to evaluate instructor performance.

The panel of three specialists, a group of experienced design and technology faculty members at Kean University, had evaluated all of the 11 available forms (See Appendix B). It was unanimously decided that Form E had the closest fit. An examination of several inappropriate questions had clarified the system further. Forms such as Form I, and Form J were ignored for a rather large percentage of irrelevant questions. Other forms, such as Form X, for example, contained a question that stated "Assigned readings and other out-of-class work were valuable". This particular CAD continuing education course did not contain assigned readings. In addition, another question on the same form (X) stated "Developing an ability to express your self in writing or orally in this field." In this class, there is no explicit ability to express your self in writing, etc. Most of the rejected forms contained numerous questions of the type just

illustrated. Form E contained the least number of questions that attempt to rate the professor, in addition to being quite relevant to accurately reflect the focus and the scope of this work. Therefore, Form E was chosen for this study. The choice of Form E represents a useful instrument that will yield acceptable results for all student satisfaction assessment endeavors in this study.

A number of additional established assessment instruments were utilized in this study. The instruments listed below were identified as appropriate starting points for the creation of an assessment tool for in-class, computer-based, and online instruction (Harrison, Seeman, Behm, Saba, Molise, & Williams, 1991; Jegede, Fraser, & Curtin, 1995). These instruments were chosen because they are grounded in educational theories and have undergone an extensive statistical validation process. The minor modifications of some of the instruments, after all the proper permissions are obtained, were reviewed by the panel of experts, to ensure accurate and effective assessment of the project results. In addition, all of the assessment instruments were extensively utilized during the pilot study, conducted prior to the experimentation. During that time (i.e. pilot study), the quality of these instruments was established by the scrutiny of statistical validation, as well as acceptable content validity (the instruments were analyzed in detail, as to quality and relevancy of each question to the specific list of expectations, objectives, and outcomes. See Appendix C).

Three specific instruments were used in this study.

1. ***Cognitive Profile Inventory***

The Cognitive Profile Inventory is based on Dr. Carl Jung's theory of personality types. The inventory was developed and validated by Dr. Krause at Clemson University and will be used to establish cognitive profiles of the

entire population under investigation (Barnett, 1994; Briggs & Myers, 1991; Jung, 1990; Krause, 2000). Since this study is involved in introducing different ways of learning, the results of this inventory will enable the researcher to better understand the learning style profiles of the studied category of students.

## 2. *Student Satisfaction Inventory*

Briefly mentioned earlier in this chapter, the Student Satisfaction Inventory, officially represented as IAS (Instructional Assessment System), was developed by the Office of Educational Assessment (OES) at the University of Washington. Originally developed to evaluate in-class courses using standard computer-scannable forms, it is among the oldest and largest student ratings programs in the nation. Scannable forms are used to assess more than 11,000 courses annually at the University of Washington. In addition, IAS services are utilized at 30 other post-secondary institutions nationwide. The study will utilize an existing standard IAS-Form E, consisting of 22 validated questions, allowing focused and precise assessment of objective student satisfaction (Gillmore, 1998; OES-UW, 2002).

## 3. *AutoCAD Achievement Examination*

AutoCAD 2000 Achievement Examination, developed by the author and utilized in this study, had served a two-fold purpose. First, it enabled a focused and measurable quantitative assessment of the student achievement during the experimental stage of the study. Second, it prepared students, who wish to further pursue their technical career by taking the Autodesk- certified, internationally accepted, prestigious AutoCAD Certification Examination (Kalameja, 2000). This assessment instrument is a slight modification of such an examination. The interface and general layout, presented by the author, are almost identical to the Certification Examination. The content of the questions (including text and graphics), as well as multiple-choice answers are modified

to more precisely reflect the content of the material presented in the AutoCAD course at Kean University, where the study was conducted.

As mentioned previously, prior to the beginning stages of the study, the AutoCAD Achievement Examination, described above, underwent the scrutiny of the formal validation process. In developing this instrument (consisting of 75 questions), item validity of this test was assured by means of a review by an independent panel, described earlier in this study, consisting of Computer Aided Design, Engineering and Technology experts from one of the largest New Jersey State Universities, as well as an expert representative from the industrial sector. The panel examined the instruments and appraised each question comparing it to the specific list of objectives, covering the span of the material presented in the course. The results of the item validity from each participating rater, reported by filling a special form containing a Likert-type scale, was analyzed, using comparative statistical analysis. To assure the highest levels of test quality, the panel's comments and suggestions were taken into consideration and corrected first. Then, in order to establish internal consistency of the instrument, a split-half reliability analysis was calculated for each test, utilizing Pearson's coefficient of correlation (Gay & Airasian, 2000).

### **Statistical Analysis**

All statistical tests in the study were conducted with a significance level of  $\alpha = 0.05$  to assure the 95% accuracy (Terrell, 2001). There are three categories of statistical analysis that were used in the study:

1. **Cognitive Profile Inventory**, establishing a statistical matrix of the individual students' learning styles.
2. **Objective student satisfaction**, evaluating three methods of instruction (in-class, instructor-facilitated online course, and independent CD-ROM based course), using IAS-Form E.
3. **Academic achievement**, an academic achievement test (developed by the author), measuring the mastery of material in each of the three methods of instruction (in-class, instructor-facilitated online course, and independent CD-ROM based course).

### **Cognitive Profile Inventory**

The results from the Cognitive Profile Inventory will be reported in both, graphical and numerical formats (See Appendix E)

- Instrument used:** Cognitive Profile Inventory
- Instrument provider:** Clemson University
- Instrument Validity Data:** Chi Square analyses resulted in probabilities of 0.87 or higher for every breakout, showing all demographics to be random by this function. The analyses were accomplished on the Clemson mainframe, a bank of 4 HITACHI Model 3090 machines. The statistical package used was SAS ®, Proprietary software release 6.07 TS305 licensed to Clemson University, site 0001151001, from the SAS Institute Inc., Cary, NC. (Krause, 2004).

### **Objective Student Satisfaction**

- Instrument used:** Student Satisfaction Inventory (*Standard Form "E"*), henceforth represented in this study as IAS (Instructional Assessment System).



- Instrument provider:** Purchased from the Office of Educational Assessment (OES) at the University of Washington.
- Instrument Validity Data:** Complete set of validity data is published by the University of Washington, and is readily available for non-profit research. (<http://www.washington.edu/oea/describe.htm#validity>)
- Inter-Rater Reliability:** The inter-rater reliabilities were computed based on 13,345 University of Washington students (with an average class size of 20 students). The results for individual question groups (total of 22 questions analyzed) are as following:

	<u><math>\bar{X}</math></u>
Questions 1- 4 . . . . .	0.87
Questions 5 - 15 . . . . .	0.88
Questions 16- 22 . . . . .	0.86

- Reporting of Data:** The data was reported by each group at the end of the study, representing different methods of instruction (3 in total) using standard IAS Form-E. The questions were answered using a six-point Likert scale: 5 = Excellent, 4= Very Good, 3= Good, 2= Fair, 1= Poor, and 0= Very Poor.

- Independent Variable(s):** There is one independent variable (method of instruction)

There are three factors of the independent variable:

1. Traditional in-class method
2. Instructor-facilitated online method
3. Independent CD-ROM method

**Statistical Data Provided:**

Data was recorded for each student, for each question.

Standard report forms available at IAS-UW contain a number of respondents, percentages of answers for each of the 22 questions, actual mean, median, and standard deviation for the entire group of students.

<b>I nstructional A ssessment S ystem</b>	CS 101 AA								
	Introduction to Computing	Jane Doe							
	North campus	Fall 1999							
	Sample Online College								
<b>ONLINE STUDENT EVALUATION OF INSTRUCTION</b>									
<b>E=Excellent; VG=Very Good; G=Good; F=Fair; P=Poor; VP=Very Poor</b>									
		<b>PERCENTAGES<sup>1</sup></b>					<b>MEAN</b>	<b>MEDIAN</b>	
	<b>No. Resp's</b>	<b>E (5)</b>	<b>VG (4)</b>	<b>G (3)</b>	<b>F (2)</b>	<b>P (1)</b>	<b>VP (0)</b>		
The course as a whole was:	22	36	45	14	5			4.14 4.20	
The course content was:	21	24	43	29	5			3.86 3.89	
The instructor's contribution to student learning was:	22	55	27	14	5			4.32 4.58	
The effectiveness of the delivery format was:	22	32	45	14	9			4.00 4.10	
Relevance of required readings (Web sites, articles, texts, etc.) was:	19	32	42	16	5	5		3.89 4.06	

Figure 3. Sample report form from the Office Of Educational Assessment, University Of Washington.

In summary, there were three final forms (results from the three groups) presented in the study for the student satisfaction category. Each form represented the results of each of the three methods of the experiment. Then, these results were statistically analyzed, using Fisher's *F-test* two-way analysis of variance (ANOVA) statistical method, comparing percentage means and standard deviations of the objective student satisfaction among the three methods of instruction (in-class, instructor facilitated online course, and independent CD-ROM based course).

## Academic Achievement

The academic achievement results were recorded and reported in the following manner:

1. Grades were collected from the AutoCAD achievement examination (75 questions)
2. Analysis of Variance (ANOVA) statistical comparison was conducted among the achievement results from the three learning methods.
3. The final ANOVA report provided the sum of squares data between the groups (i.e. methods of instruction), within groups, and total; degrees of freedom; mean square (variance); F- number (Fisher's coefficient); and a significance ( $p$ ) value.
4. In cases where significant differences in academic achievement existed within the instructional methods ( $p < .05$ ), a post-hoc analysis was performed to establish the actual relationship, and where the differences actually had occurred.

The Content Validity of the achievement test was established by the panel of three experts. In Appendix C there is a list of objectives that the panel of experts used to measure the quality of the Achievement examination (criterion validity). Each question on the test was evaluated by each expert against the specific objective. The appendix C provides the list of objectives and the Appendix D provides the rating forms that were used to measure the questions against the specific objectives. There were many changes during the initial process both to the test and the objective list. The test went through a

number of modifications before it was used first during the pilot, and in the final experiment. The rating form in Appendix D were broken into 3 parts (questions 1-25, 26-50, 51-75). There were 8 objectives in each module, and 25 rating components, each rated on the Likert scale. Therefore the entire content of the Achievement test was scrutinized and rated. The inter reliability was established by analyzing the mean statistics and a variance of results among the raters. Furthermore, the test results during the pilot studies and the experiment were randomly split in two halves and analyzed for consistency and unanimously found reliable within a statistically acceptable range ( $\alpha = 0.87$ ).

### **Resources**

In most cases, when alternate methodologies are being implemented at educational or corporate institutions, it might require a significant initial investment (e.g. computer equipment, instructor training, etc.) (Perelman, 1992). At the time of the study, however, no special, unusual, or hard-to-obtain resources, necessary to complete the study, were identified. The author holds a position of Director of Continuing and Professional Engineering and Technology Education at Kean University, Union NJ. For the past 20 years he has been actively involved in the educational projects related to Computer Aided Design, Manufacturing, Computer Integration in Engineering, as well as other related disciplines.

### **Summary**

Although, based on the review of relevant literature and the results of the pilot studies conducted by the researcher, the outcomes of the study may have seemed to be

somewhat predictable. However, since the pilot studies involved only registered students, most of them being representatives of the manufacturing industries, posed a serious limitation in the interpretation of the obtained results (i.e. pilot study results). The actual experiment involved a much broader cross-section of the population, namely the representatives of construction / architectural trades, as well as a much broader spectrum of mixed professions and educational backgrounds. Additionally, the conducted pilot studies involved a hyperlearning methodology where all of the participating students received identical treatment involving all three methods (i.e. in-class, semi-independent online course, and completely independent CD-ROM based course) of instruction within the same course. In the actual experimental study three separate random groups had received different treatments, assuring a more precisely measurable and conclusive outcome results.

The study results may offer a significant educational value to technology, engineering, and computer science students. The author was able to obtain complete support from the University's administration, faculty and staff.

## **Chapter 4**

### **Data Analysis**

Chapter 4 provides information on the results of the study analyses. The chapter begins by restating the purpose and specific goals, as well as reiterates the design of the study. Next, a description of the population sample followed by descriptive statistics on key variables. Lastly, each section begins with a restatement of a specific aim and is followed by the results of analyses.

#### **Purpose and Specific Aims**

The purpose of the study was to compare the three methods of instructional delivery to determine if the online and CD-ROM based training will be as effective as the traditional classroom-based course. The experimental design consisted of three randomly selected sample groups. Each group consisted of 20 adult Continuing Education students 30-50 years of age. The independent variable in the study was the instructional method. The dependent variables were the academic achievement scores and the satisfaction levels of the participants. Of the three groups of adult Continuing Education students, the first group received the traditional classroom training (control group), the second group received an online course (treatment group 1), and the third group was trained independently, using a CD-ROM-based course (treatment group 2). Data was gathered regarding the achievement scores and participant satisfaction levels of all three groups. Upon completion of the course, two specific assessment instruments were administered to all of the participants. These statistically validated instruments were used to measure the

differences in learning achievement (test scores) and course satisfaction of all participating students.

The primary aim of the study was to measure the academic achievement and overall course satisfaction differences of adult students, according to their individual ability levels, when taught by three methods of instruction. More specifically, the study aimed to answer the following research questions by conducting a series of experimental analyses:

1. Is there a significant difference in objective course satisfaction among the three methods of instruction among adult Continuing Education students learning Computer Aided Design?
2. Is there a significant difference in academic achievement among the three methods of instruction among adult Continuing Education students learning Computer Aided Design?
3. Is there any correlation between the cognitive profiles of the students and academic achievement results among adult Continuing Education population learning Computer Aided Design? (In this case Pearson's and Spearman's correlation statistical techniques were used to demonstrate whether and how strongly pairs of two variables, achievement and students' learning profiles are related).

Before the primary aim could be accomplished, there were three subordinate aims that were addressed first:

1. Establish content validity of the academic achievement assessment instrumentation developed by the author through consultation with several

academic experts in Computer Aided Design education. The measurement was performed using an Inter-Rater Reliability method.

2. Establish construct validity and reliability of all instrumentation used by conducting a series of pilot studies, as well as a number of individual inter-instrument reliability measurements. This included the following:
  - Autocad Achievement Examination, assessing the consistency of a measure from one time to another, using a “Test-Retest” reliability method.
  - Cognitive profile inventory, assessing the reliability of the instruments and examining internal consistency, using a “Split-Half” reliability method.
  - Standard Student Satisfaction form, measuring consistency of results across items within a test, using an “Internal Consistency Reliability” method.

### **Description of the Sample and Demographics**

The population of the study consisted of randomly selected Continuing Education students at Kean University, located in Union, New Jersey. The experiment, having received full support of the University administration, was conducted during the spring semester of 2005. To assure diversity of the sample cross-section, the population sample was drawn from both, University students and industry representatives. Obtaining all required permissions from the management, special advertisement announcements were posted at several New Jersey mid-range companies in and around Union County



(approximately a 20 mile range from the University), specifying that the Autocad course was available at the University at no cost to the students (see Appendix M). The advertisement also specified that people from a wide range of professional backgrounds were welcome to apply for the course. Although everybody who applied had direct or indirect association with technology, manufacturing, and/or engineering related fields, the population sample offered a professional cross-section spanning a majority of technical fields and professional variations. To explain this further, among the registered students were quality control inspectors, metal-cutting and plastic injection molding machinists, drafters, mechanical and electrical engineers, and production control expeditors (this profession is more clerical than technical in nature). Additionally, there were some representatives from the Architectural profession as well. As said earlier, all of the above professional fields are related, to some extent, to the field of Computer Aided Design which is now utilized as a standard tool for design, architecture, as well as production collaboration and scheduling (e.g. “Just-In-Time” JIT and “Manufacturing Requirement Planning” MRP manufacturing practices).

### **Descriptive statistics of the population sample**

There were 116 students who responded to the registration advertisements. Only 60 of these students were randomly selected to participate in the study. The ethnic cross-section of the student population was as follows: 29 Caucasian (48%), 19 Hispanic (32%), and 12 African American students (20%). Also, it may be of some importance to note that among the Caucasian registrants, approximately 25% were immigrants of Eastern-European descent (i.e. Poland, Russia, Ukraine, and Germany). Additionally, the population sample was mostly represented by male participants; however, there was an

adequate representation of women in the selection as well. In total there were 49 male and 11 female students. All subjects ranged in age from 30-50 years, with a majority of the subjects between 36-48 years of age (approximately 65%). Most of the participants live in suburban areas of New Jersey (90%). The urban part of the population was represented by the city of Elizabeth, which by some standards may represent a semi-urban to urban environment. It was explained to the students that the course will be offered in one of three instructional settings (i.e. in class, online, and by independent study using a CD-ROM based course). It was also explained to all of the participating registrants that they would be randomly assigned to one of the three instructional methods. There was no hesitation or objections on their part, because it is now common knowledge that a vast majority of Colleges and Universities across the country are offering a wide variety of courses in non-traditional delivery formats.

A majority of the students (80%) indicated that they enrolled in the course because in today's economy it is almost a requirement to be proficient, or at least be familiar with some type of CAD system, and since Autocad represents a sizable percentage of CAD users' market, the offer to take a free course seemed to be of high value. For other students it was a requirement to take this course as a part of a broader technical Continuing Education curriculum offered at Kean University.

### **Statistical Analysis of the Experiment**

The statistical results of the experiment are described below in three sections:

- Section 1:** Academic Achievement Results
- Section 2:** Student Evaluation of Instruction (Objective Satisfaction)
- Section 3:** Cognitive Profile Data and Analysis

## Section 1: Academic Achievement Results

### Actual Grades Table

Group #	Method	N	Actual Test Grade List
1	In-Class	20	82,90,85,72,80,72,94,72,69,88,84,90,75,69,83,67,94,77,89,71
2	Online	20	61,79,69,62,59,57,82,72,61,68,47,88,76,59,75,72,69,71,77,62
3	CD-ROM	20	72,68,64,79,82,93,97,81,64,90,76,69,83,68,98,62,54,73,89,73

**Table 1.** Actual Grades Table

### Descriptive Statistics Results

#### Group 1 (In class method)

20 data points were entered:

Data below is sorted in the ascending order:

67.0 69.0 69.0 71.0 72.0 72.0 72.0 75.0 77.0 80.0 82.0 83.0 84.0 85.0 88.0  
89.0 90.0 90.0 94.0 94.0

Mean = 80.150

95% confidence interval for actual Mean: 75.98 thru 84.32

Standard Deviation = 8.911

Average Absolute Deviation from Median = 7.750

Median = 81.000

Hi = 94.0 Low = 67.000

Standard Error of the Mean = 1.992

## Group 2 (Online Method)

20 data points were entered:

Data below is sorted in the ascending order:

47.0 57.0 59.0 59.0 61.0 61.0 62.0 62.0 68.0 69.0 69.0 71.0 72.0 72.0  
75.0 76.0 77.0 79.0 82.0 88.0

Mean = 68.300

95% confidence interval for actual Mean: 63.69 thru 72.91

Standard Deviation = 9.857

Average Absolute Deviation from Median = 7.800

Median = 69.000

Hi = 88.0 Low = 47.000

Standard Error of the Mean = 2.204

## Group 3 (Independent CD-ROM Method)

20 data points were entered:

Data below is sorted in the ascending order:

54.0 62.0 64.0 64.0 68.0 68.0 69.0 72.0 73.0 73.0 76.0 79.0 81.0 82.0  
83.0 89.0 90.0 93.0 97.0 98.0

Mean = 76.750

95% confidence interval for actual Mean: 71.00 thru 82.50

Standard Deviation = 12.281

Average Absolute Deviation from Median = 10.100

Median = 74.500

Hi = 98.0 Low = 54.0

Standard Error of the Mean = 2.746

Shown below, are percentile graphical plots for the three groups:

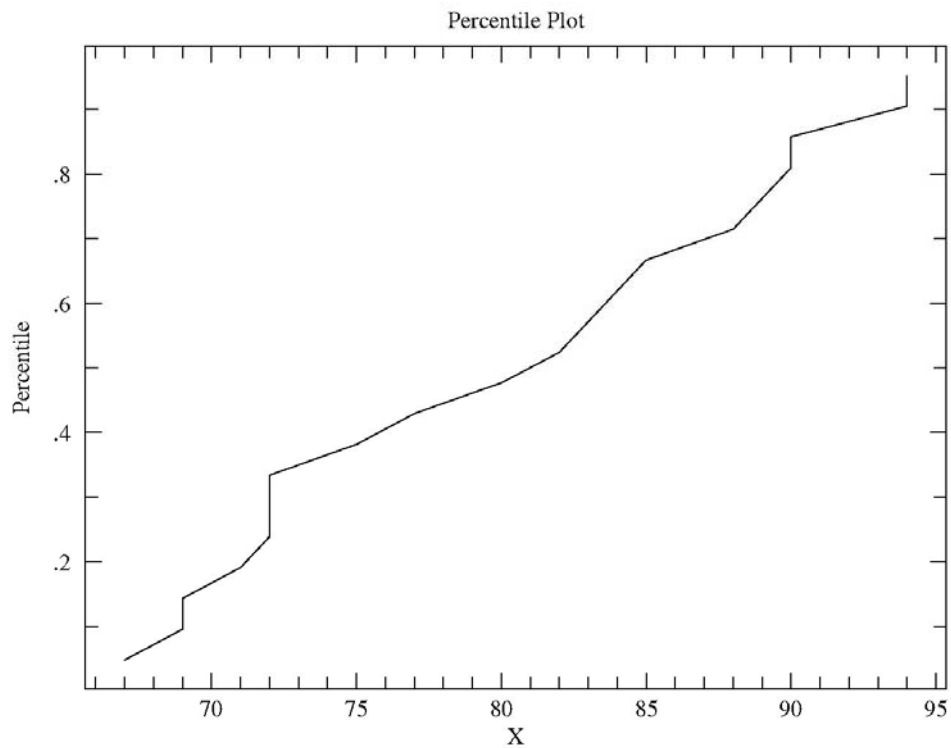

**Figure 4.** Group 1 Percentage Plot

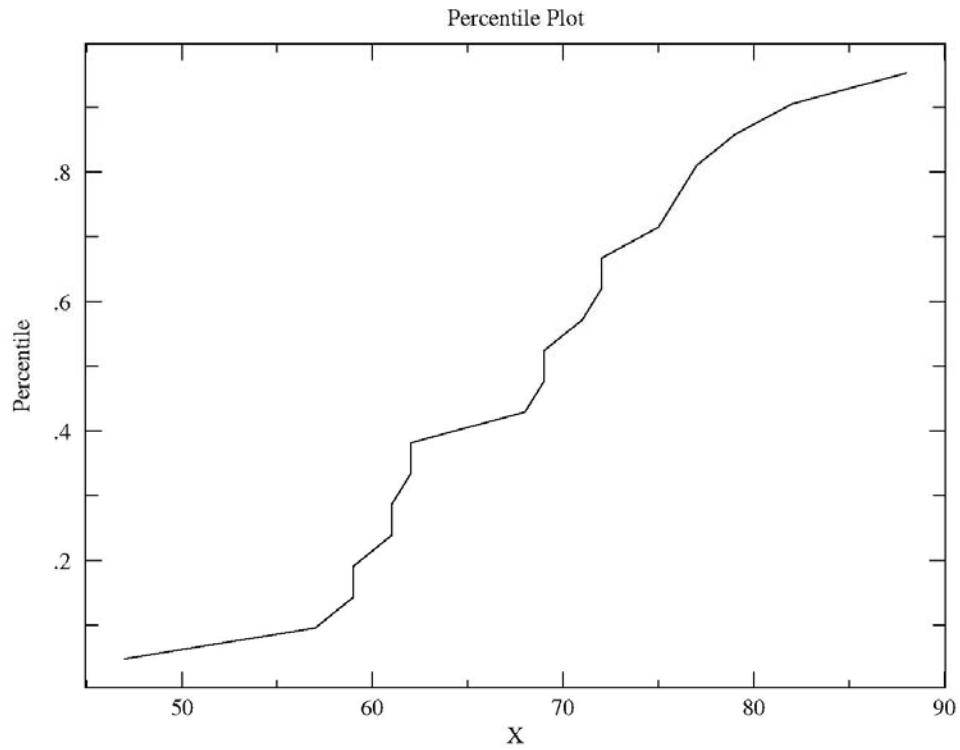

**Figure 5.** Group 2 Percentage Plot

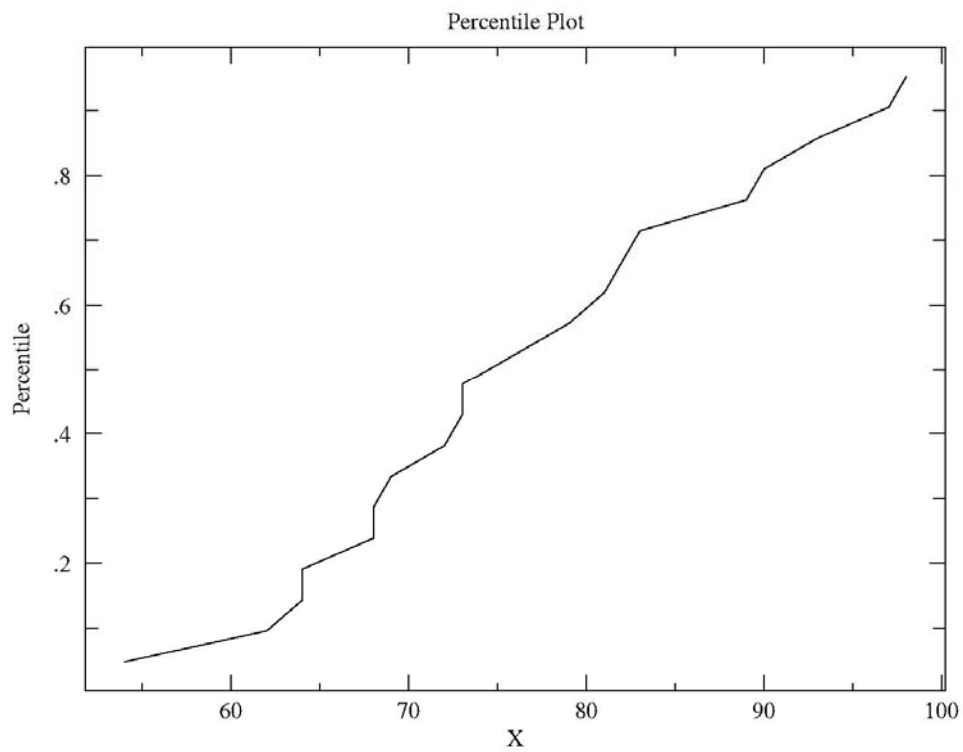

**Figure 6.** Group 3 Percentage Plot

**Achievement Statistics Summary Table**

<b>Group #</b>	<b>Method</b>	<b>N</b>	<b>Mean</b>	<b>Standard Deviation</b>	<b>Standard Error of the Mean</b>	<b>Median</b>
<b>1</b>	<b>In-Class</b>	20	80.150	8.911	1.992	81.000
<b>2</b>	<b>Online</b>	20	68.300	9.857	2.204	69.000
<b>3</b>	<b>CD-ROM</b>	20	76.750	12.281	2.746	74.500

**Table 2.** Achievement Statistics Summary**Achievement Statistics Results****Analysis of Variance Calculations  
ANOVA**

	<i>Sum of Squares</i>	<i>DF</i>	<i>Mean Square (Variance)</i>	<i>F</i>	<i>Significance (p value)</i>
<b>Between Groups</b>	1489.20	2	744.60	6.823	0.0022 <sup>1</sup>
Within Groups	6220.40	57	109.10		
Total	7709.60	59			

**Table 3.** Achievement Statistics Analysis of Variance

---

<sup>1</sup> P-value is less than alpha value (.05): There is a significant difference among the three methods of instruction

**Post-hoc t-test**

<b>Method</b>	<b>Method</b>	<b>t-value</b>	<b>DF</b>	<b>Probability</b>
In-Class	Online	3.587	38	0.0009
In-Class	CD-ROM	1.029	38	0.3099
Online	CD-ROM	-2.558	38	0.0146

**Table 4.** Achievement Statistics Post-hoc t-Test**Academic Achievement Statistics Result Summary:**

The results of the academic achievement statistics, described in Table 4, had conclusively shown that a significant difference does exist between in-class and semi-independent online course (Methods 1 and 2), where in-class method is showing higher academic achievement results. There is also a statistically significant difference between semi-independent, online course and the independent CD-ROM-based course (Methods 2 and 3). In this case the independent method has shown to be more effective than the online method. There was no statistically significant difference between the in-class and the independent CD-ROM methods (Methods 1 and 3).

**Section 2: Student Evaluation of Instruction***Student Satisfaction Inventory*

Briefly mentioned earlier in Chapter 3, the Student Satisfaction Inventory, officially represented as IAS (Instructional Assessment System), was developed by the Office of Educational Assessment (OES) at the University of Washington. The study is utilizing an existing standard IAS-Form E, consisting of 22 validated questions, allowing focused and precise assessment of objective student satisfaction (OES-UW, 2005).



**Group 1**  
**STUDENT EVALUATION OF INSTRUCTION**

**Autocad (In-class Training Course)**

**E=Excellent(5); VG=Very Good(4); G=Good(3);F=Fair(2); P=Poor(1);**

	<b>Description</b>	<b>N</b>	<b>E%</b>	<b>VG %</b>	<b>G%</b>	<b>F%</b>	<b>P%</b>	<b>VP %</b>	<b>Median</b>	$\bar{X}$	<b>SD</b>
1	The course as a whole was:	20	70	25	5	-	-	-	5.0	4.650	0.587
2	The course content was:	20	80	20	-	-	-	-	5.0	4.800	0.410
3	The instructor's contribution to the Course was:	20	50	35	10	5	-	-	4.5	4.300	0.865
4	The instructor's effectiveness in teaching the subject matter was:	20	35	25	35	5	-	-	4.0	3.900	0.968
5	Opportunity for practicing what was learned was:	20	55	35	10	-	-	-	5.0	4.450	0.686
6	Sequential development of skills was:	20	25	15	40	15	5	-	3.0	3.400	1.188
7	Explanation of underlying rationales for new techniques or skills were:	20	10	25	50	5	5	5	3.0	3.150	1.182
8	Demonstrations of expected skills were:	20	15	40	35	51	5	-	4.0	3.550	0.999
9	Instructor's confidence in students' ability was:	20	60	35	5	-	-	-	5.0	4.550	0.605
10	Recognition of student progress by instructor was:	20	70	25	5	-	-	-	5.0	4.650	0.587
11	Student confidence in instructor's knowledge was:	20	80	20	-	-	-	-	5.0	4.800	0.410
12	Freedom allowed students to develop own skills and ideas was:	20	50	25	20	5	-	-	4.5	4.200	0.951
13	Instructor's ability to deal with student difficulties was:	20	30	40	20	5	-	-	4.0	3.900	0.968
14	Tailoring of instruction to varying student skills levels was:	20	15	35	45	5	-	-	3.5	3.600	0.821
15	Availability of extra help when needed was:	20	85	10	5	-	-	-	5.0	4.800	0.523
16	Use of class time was:	20	40	50	10	-	-	-	4.0	4.300	0.657
17	Instructor's interest in whether students learned was:	20	65	30	-	5	-	-	5.0	4.550	0.759
18	Amount you learned in the course was:	20	40	50	10	-	-	-	4.0	4.300	0.657
19	Relevance and usefulness of course content were:	20	50	40	5	5	-	-	5.0	4.500	0.607
20	Evaluative and grading techniques (test, projects, etc.) were:	20	35	30	15	15	5	-	4.0	3.750	1.251
21	Reasonableness of assigned work was:	20	25	35	35	5	-	-	4.0	3.800	0.894
22	Clarity of student responsibilities and requirements was:	20	45	50	5	-	-	-	4.0	4.400	0.598
	<b>Grand Totals</b>									4.195	.781

**Group 2**  
**STUDENT EVALUATION OF INSTRUCTION**  
Autocad (Semi-Independent, Online Course)  
E=Excellent(5); VG=Very Good(4); G=Good(3);F=Fair(2); P=Poor(1);

	<b>Description</b>	<b>N</b>	<b>E%</b>	<b>VG %</b>	<b>G%</b>	<b>F%</b>	<b>P%</b>	<b>VP %</b>	<b>Median</b>	<b><math>\bar{X}</math></b>	<b>SD</b>
1	The course as a whole was:	20	25	35	35	5	-	-	4.0	3.800	0.894
2	The course content was:	20	-	30	55	10	5	-	3.0	3.100	0.788
3	The instructor's contribution to the Course was:	20	20	40	35	5	-	-	4.0	3.750	0.851
4	The instructor's effectiveness in teaching the subject matter was:	20	15	45	25	15	-	-	4.0	3.600	0.940
5	Opportunity for practicing what was learned was:	20	25	25	45	5	-	-	3.5	3.700	0.923
6	Sequential development of skills was:	20	30	35	35	-	-	-	4.0	3.950	0.826
7	Explanation of underlying rationales for new techniques or skills were:	20	-	40	55	-	5	-	3.0	3.300	0.733
8	Demonstrations of expected skills were:	20	15	35	50	-	-	-	3.5	3.650	0.745
9	Instructor's confidence in students' ability was:	20	30	25	10	30	-	5	4.0	3.400	1.465
10	Recognition of student progress by instructor was:	20	35	25	30	10	-	-	4.0	3.850	1.040
11	Student confidence in instructor's knowledge was:	20	-	40	30	20	5	5	3.0	2.950	1.146
12	Freedom allowed students to develop own skills and ideas was:	20	20	35	20	25	-	-	4.0	3.500	1.100
13	Instructor's ability to deal with student difficulties was:	20	-	10	45	40	5	-	3.0	2.600	0.754
14	Tailoring of instruction to varying student skills levels was:	20	5	30	25	25	10	5	3.0	2.800	1.281
15	Availability of extra help when needed was:	20	35	40	20	5	-	-	4.0	4.050	0.887
16	Use of class time was:	20	-	45	40	5	5	5	3.0	3.150	1.089
17	Instructor's interest in whether students learned was:	20	-	35	40	25	-	-	3.0	3.100	0.788
18	Amount you learned in the	20	50	15	15	15	5		4.5	3.900	1.334
19	Relevance and usefulness of course content were:	20	35	40	15	10	-	-	4.0	4.000	0.973
20	Evaluative and grading techniques (test, projects, etc.) were:	20	-	25	30	45	-	-	3.0	2.800	0.834
21	Reasonableness of assigned work was:	20	-	20	30	35	15	-	2.5	2.550	0.999
22	Clarity of student responsibilities and requirements was:	20	30	25	10	30	5	-	4.0	3.450	1.356
	<b>Grand Totals</b>									3.407	21.746

**Group 3**  
**STUDENT EVALUATION OF INSTRUCTION**  
**Autocad (Independent, CD-ROM Training Course)**  
 E=Excellent(5); VG=Very Good(4); G=Good(3);F=Fair(2); P=Poor(1);

	Description	N	E%	VG %	G%	F%	P%	VP %	Median	$\bar{X}$	SD
1	The course as a whole was:	20	35	40	25	5	-	-	4.0	3.950	0.887
2	The course content was:	20	20	45	30	5	-	-	4.0	3.800	0.834
3	The instructor's contribution to the Course was:	20	30	60	10	-	-	-	4.0	4.200	0.616
4	The instructor's effectiveness in teaching the subject matter was:	20	45	30	20	5	-	-	4.0	4.150	0.933
5	Opportunity for practicing what was learned was:	20	15	45	20	5	5	10	4.0	3.300	1.490
6	Sequential development of skills was:	20	-	50	35	15	-	-	3.5	3.350	0.745
7	Explanation of underlying rationales for new techniques or skills were:	20	15	30	50	5	-	-	3.0	3.550	0.826
8	Demonstrations of expected skills were:	20	20	45	25	10	-	-	4.0	3.750	0.910
9	Instructor's confidence in students' ability was:	20	25	45	25	5	-	-	4.0	3.900	0.852
10	Recognition of student progress by instructor was:	20	-	45	35	10	5	5	3.0	3.100	1.119
11	Student confidence in instructor's knowledge was:	20	30	40	30	-	-	-	4.0	4.000	0.795
12	Freedom allowed students to develop own skills and ideas was:	20	25	40	20	10	5	-	4.0	3.700	1.129
13	Instructor's ability to deal with student difficulties was:	20	45	30	15	-	5	5	4.0	3.950	1.395
14	Tailoring of instruction to varying student skills levels was:	20	20	40	25	10	5	-	4.0	3.600	1.095
15	Availability of extra help when needed was:	20	30	25	25	20	-	-	4.0	3.650	1.137
16	Use of class time was:	20	25	45	20	5	5	-	4.0	3.800	1.056
17	Instructor's interest in whether students learned was:	20	50	40	5	-	5	-	4.5	4.300	0.979
18	Amount you learned in the course was:	20	30	40	25	5	-	-	4.0	3.950	0.887
19	Relevance and usefulness of course content were:	20	35	35	30	-	-	-	4.0	4.050	0.826
20	Evaluative and grading techniques (test, projects, etc.) were:	20	20	50	10	10	5	5	4.0	3.550	1.356
21	Reasonableness of assigned work was:	20	5	50	30	5	10	-	4.0	3.350	1.040
22	Clarity of student responsibilities and requirements was:	20	15	40	25	15	5	-	4.0	3.450	1.099
	Grand Totals									3.745	1.000

**Table 5.** Student Evaluation of Instruction (3 tables for all groups)

**Satisfaction Statistics Summary Table**

<b>Group #</b>	<b>Method</b>	<b>N</b>	<b>Mean</b>	<b>Standard Deviation</b>
<b>1</b>	<b>In-Class</b>	20	4.195	.781
<b>2</b>	<b>Online</b>	20	3.407	21.746
<b>3</b>	<b>CD-ROM</b>	20	3.745	1.000

**Table 6.** Student Satisfaction Summary Table**Satisfaction Statistics Results****Analysis of Variance Calculations  
ANOVA**

	<i>Sum of Squares</i>	<i>DF</i>	<i>Mean Square (Variance)</i>	<i>F</i>	<i>Significance (p value)</i>
<b>Between Groups</b>	6.30	2	3.10	0.020	0.9804 <sup>2</sup>
Within Groups	9015.50	57	158.20		
Total	9021.70	59			

**Table 7.** Student Satisfaction Analysis of Variance**Post-hoc t-test**

<b>Method</b>	<b>Method</b>	<b>t-value</b>	<b>DF</b>	<b>Probability</b>
1	2	0.198	38	0.8440
1	3	0.113	38	0.9105
2	3	-0.085	38	0.9327

**Table 8.** Student Satisfaction Post-hoc t-Test**Result Summary:**

There is no statistically significant difference within the three methods of instruction.

<sup>2</sup> P-value is greater than alpha value (.05): There is no significant difference among the three methods of instruction

### Section 3: Cognitive Profile Data Results

<b>Student No.</b>	<b>ST Sensor Thinker</b>	<b>SF Sensor Feeler</b>	<b>NT Intuitive Thinker</b>	<b>NF Intuitive Feeler</b>	<b>Dominant Pair</b>
1	53	18	61	34	NT, ST
2	62	40	70	25	NT, ST
3	28	22	31	51	NF, NT
4	34	56	61	19	NT, SF
5	51	27	63	44	NT, ST
6	19	47	36	61	NF, SF
7	48	22	44	16	ST, NT
8	29	32	51	21	NT
9	67	29	48	23	ST, NT
10	41	62	19	25	SF, ST
11	47	19	52	18	NT, ST
12	21	23	49	54	NF, NT
13	61	17	37	48	ST, NF
14	25	49	72	28	NT, SF
15	63	65	40	32	SF, ST
16	42	43	19	32	SF, ST
17	49	21	51	23	NT, ST
18	44	18	62	33	NT, ST
19	51	49	28	57	NF, ST
20	62	21	40	23	ST, NT
21	58	42	64	36	NT, ST
22	21	44	62	19	NT, SF
23	57	29	54	28	ST, NT
24	21	58	64	33	NT, SF
25	45	32	59	27	NT, ST
26	25	71	52	33	SF, NT
27	63	18	25	46	ST, NF
28	38	56	27	59	NF, SF
29	19	44	37	57	NF, SF
30	23	64	19	58	SF, NF
31	51	29	58	33	NT, ST
32	49	20	61	28	NT, ST
33	42	28	53	20	NT, ST
34	34	62	27	58	SF, NF
35	60	18	56	35	ST, NT
36	23	52	39	71	NF, SF
37	59	27	30	56	ST, NF
38	54	19	35	62	NF, ST
39	64	39	59	23	ST, NT

40	27	49	63	34	NT, SF
41	65	38	64	23	ST, NT
42	40	18	54	29	ST, NT
43	56	44	68	35	NT, ST
44	57	26	62	31	NT, ST
45	56	42	62	31	NT, ST
46	49	61	23	57	SF, NF
47	63	21	44	18	ST, NT
48	28	43	37	35	SF, NT
49	51	23	68	31	NT, ST
50	39	29	56	16	NT, ST
51	70	30	42	26	ST
52	44	40	58	21	NT, ST
53	29	53	69	17	NT, SF
54	46	28	34	34	ST
55	67	23	61	35	ST, NT
56	72	36	57	29	ST, NT
57	59	18	69	40	NT, ST
58	48	29	43	31	ST, NT
59	52	32	19	44	ST, NF
60	63	17	31	24	ST

**Table 9.** Cognitive Profile Data

Table 9 represents the results of the Cognitive Profile Inventory administered to the 60 participating students at the beginning of the experiment. The major goal of this analysis was to establish the cognitive profiles of the population in all of the groups. Since this study is involved in introducing different ways of learning, the results of this inventory enable the researcher to better understand the learning style profiles of the studied category of students. As mentioned in Chapter 3, all of the students in the three groups completed a Cognitive Profile Inventory (Krause, 2000). Each cognitive profile inventory survey was marked with a distinct number for each participant. These unique numbers remained with each student throughout the entire duration of the experiment.

Later, these unique numbers were matched to achievement and satisfaction scores for further analysis.

As briefly mentioned in Chapter 1, the Cognitive Profile Inventory consisted of 60 pairs of questions. The quantitative results were obtained and graphically plotted for each student .

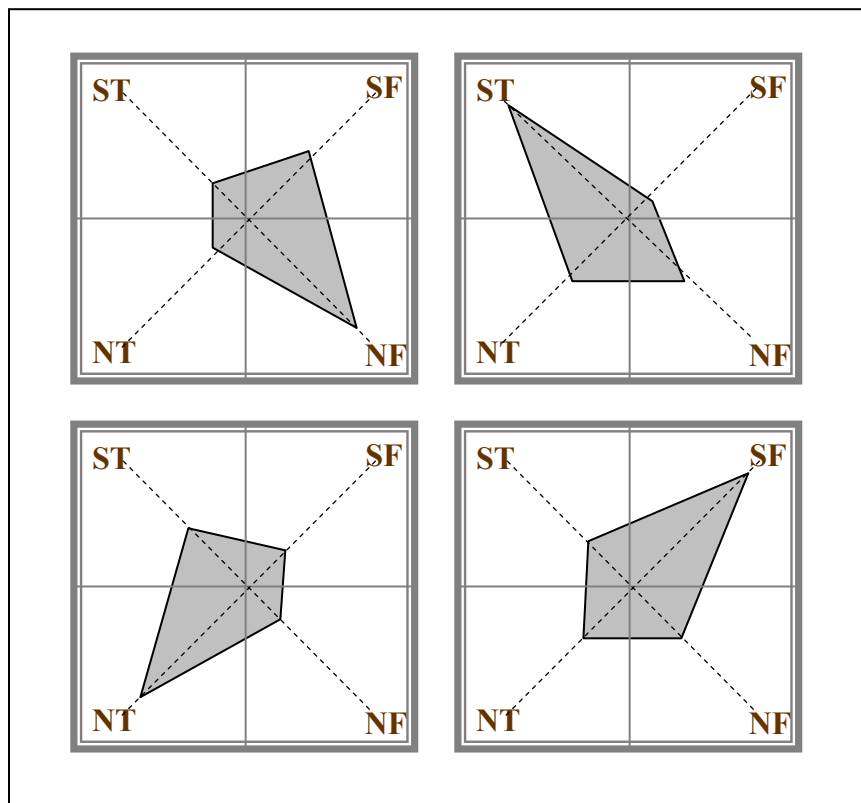

**Figure 7.** An example of four quadrilateral figures, depicting possible four different outcomes of individual students' cognitive profiles.

The Cognitive Profile shown in Table 9 represents these graphical displays in the numerical formats, thus allowing the researcher to perform more precise quantitative statistical calculations as opposed to a visual analysis (conversion to numerical format is a part of the Cognitive Profile Inventory process, it is from the numerical format the

analysts plot the graphical displays seen in the Figure 7). The higher numbers in the table represent the dominating quadrant. In addition, for a deeper cognitive profile analysis, a second dominating number was added representing a second to the highest category of the students' learning profile. For example, student Number 5 in the Table 9 is represented by a set of 4 numbers 51, 27, 63, and 44. The number 63 appears in the **NT** column, and number 51 appears in the **ST** column. As seen in the Dominant Pair column, the **NT** is specified first, as the highest dominating quadrant, and **ST** is specified second, delimited by a coma. In this case, it is possible to conclude that student Number 5 is an Intuitive Thinker (**NT**) and further skewing towards the Sensor Thinker Category (**ST**). Although it may be useful to utilize this second category values in a more detailed research, for the purpose, and due to the limited scope of this study, only the first value is used, specifying the most dominant quadrant only. Therefore, the cognitive learning profile of this particular student will be in the “**NT**” category.

The cognitive profile of the entire group of 60 students is demonstrated in the Table 10, representing the number of occurrences and percentage of each of the four categories:

<b>Cognitive Profile</b>	<b>Symbol</b>	<b>Occurrences</b>	<b>Percentage</b>
Sensor Thinker	(ST)	19	32%
Sensor Feeler	(SF)	8	13%
Intuitive Thinker	(NT)	25	42%
Intuitive Feeler	(NF)	8	13%

**Table 10.** Cognitive Profile Percentage Data



From the obtained data in the Table 10, it is therefore safe to conclude that the majority of the students used in the experiment (42%) would fit within the Intuitive Thinker category. This further supports the data obtained in the variety of technical disciplines in the past research (Krause, 2000). As briefly mentioned in Chapter 1, a definition of “*Intuitive-Thinker*” (NT) is as following: “The Intuitive-Thinker is characterized by logical thinking, perception of patterns and a strong need to understand. An intuitive thinker needs to mentally process new material alone before discussion and must see the overall picture prior to processing details to build understanding” (Krause, 2000). Also, from the data in Table 10, it may be safe to conclude that the aforementioned group of students may be well suited for the independent style of learning, be it online or via an independent CD-ROM based courses.

### **Correlation Analysis Between Academic Achievement and Cognitive Profiles of the Students**

For the purpose of establishing a correlation between academic achievement of the students and the achievement results, the four categories above (i.e. ST, SF, NT, and NF) were converted to a numerical representation, where ST is represented by number 1, SF is represented by number 2, NT by number 3, and NF by number 4. Since all of the students in the experiment were represented by a unique I.D. it was therefore possible to create a table where each student’s academic achievement is listed next to its corresponding cognitive profile number. Next, Pearson’s correlation statistical technique was used to demonstrate whether and how strongly pairs of two variables, achievement and students’ learning profiles are related (See Table 11).

<b>Student ID number</b>	<b>Test Grade</b>	<b>Cognitive Profile Number</b>
1	82	3
2	90	3
3	85	4
4	72	3
5	80	3
6	72	4
7	94	1
8	72	3
9	69	1
10	88	2
11	84	3
12	90	3
13	75	1
14	69	3
15	83	2
16	67	2
17	94	3
18	77	3
19	89	4
20	71	1
21	61	3
22	79	3
23	69	1
24	62	3
25	59	3
26	57	2
27	82	1
28	72	4
29	61	4
30	68	2
31	47	3
32	88	3
33	76	3
34	59	2
35	75	1
36	72	4
37	69	1
38	71	4
39	77	1
40	62	3
41	72	1
42	68	1

43	64	3
44	79	3
45	82	3
46	93	2
47	97	1
48	81	2
49	64	3
50	90	3
51	76	1
52	69	3
53	83	3
54	68	1
55	98	1
56	62	1
57	54	3
58	73	1
59	89	1
60	73	1

**Table 11.** Correlation Analysis Data

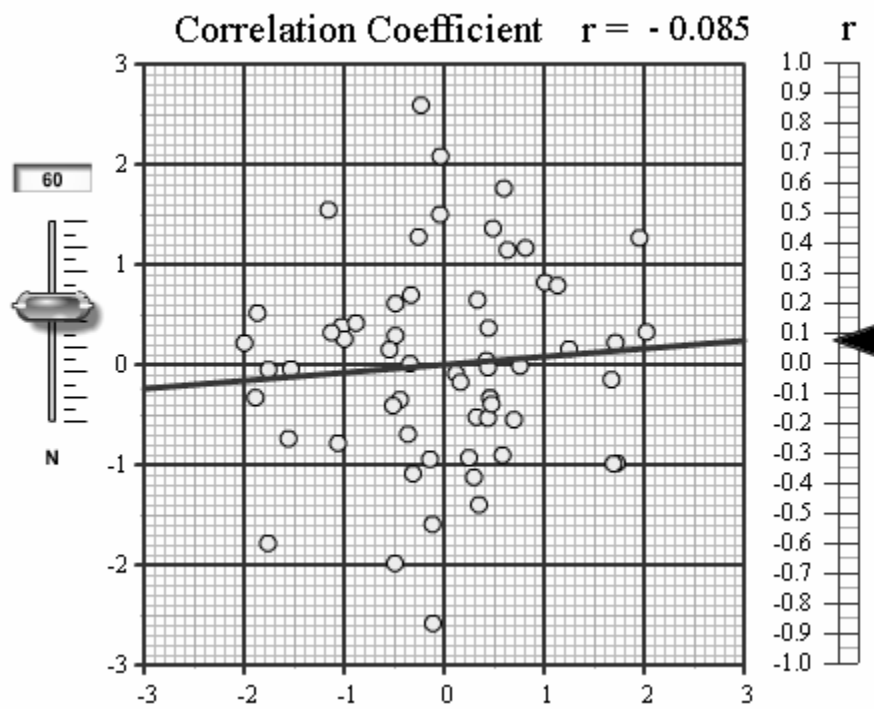

**Figure 8.** Correlations Point Plot

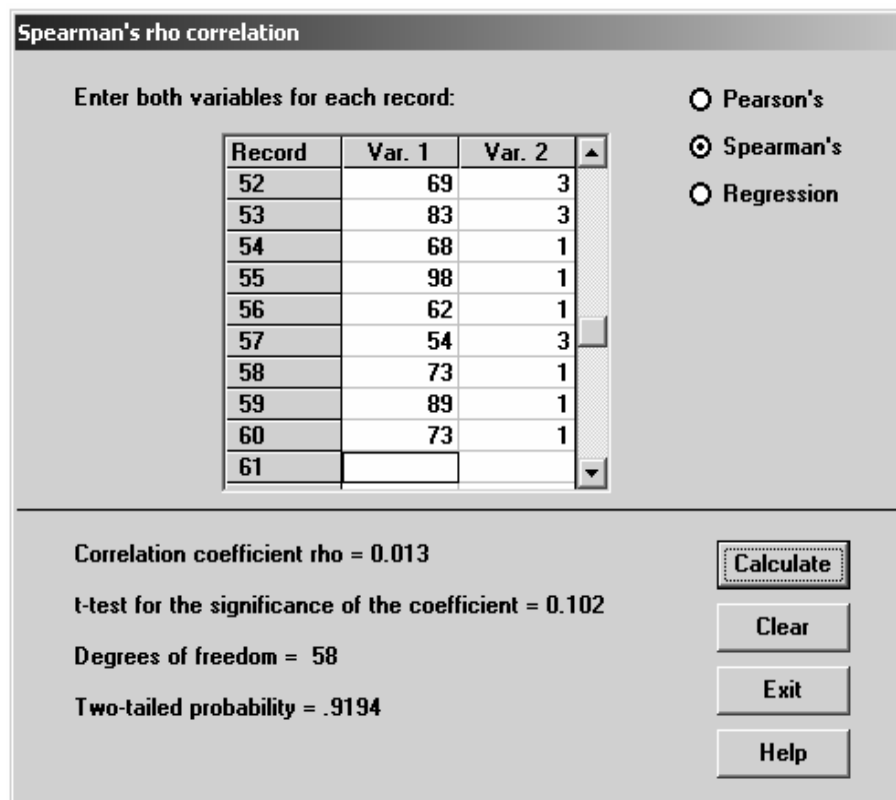
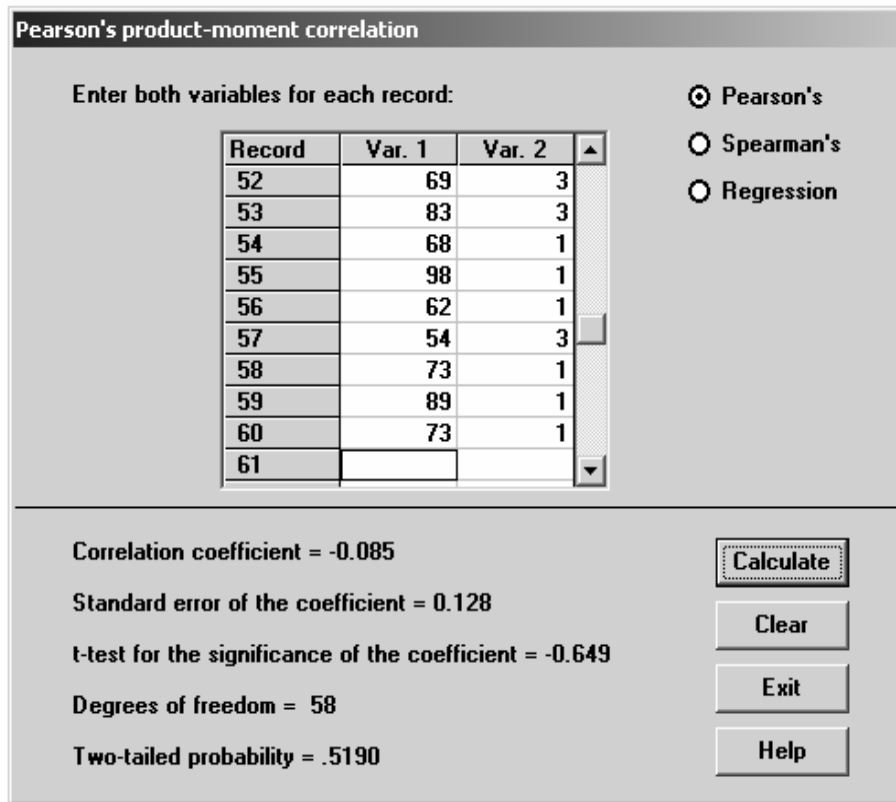

Figure 9. Correlation Analysis Results

The statistical results shown in the Figures 8 and 9 demonstrated a broadly scattered point plot, indicating in both the Pearson's product moment correlation as well as Spearman's Rho correlation, indicating a very weak relationship between the two variables. Typically, a correlation coefficient of  $< 0.1$  indicates that no significant correlation existed. Using the existing Pearson's coefficient of  $r = -.085$ , and Spearman's (Rho) coefficient of  $0.013$ , it is safe to conclude that no correlation existed between the academic achievement and learning styles of the students within the subject limitations of the current study.

It is also important to note that these results may be significantly different in a wide variety of different disciplines and subjects involving a more physical and visual contact with the instructor, such as dance lessons, karate and other sports related courses, manufacturing and shop related classes, etc.

### **Summary of Findings and Analysis of the Hypotheses**

#### *Hypothesis 1*

*There is a significant difference in objective course satisfaction within the three methods of instruction among adult Continuing Education students learning Computer Aided Design*

From the empirical results of the study, and the subsequent statistical analysis that followed, there was no significant difference among the three groups. The significance value ( $p = 0.9804$ ) was greater than the alpha value ( $.05$ ). Therefore, the above hypothesis was rejected, and it was concluded that the objective course satisfaction was equal among the three methods of instruction described in this study.

*Hypothesis 2*

*There is a significant difference in academic achievement within the three methods of instruction among adult Continuing Education students learning Computer Aided Design.*

The academic achievement results yielded the following results:

1. There was a significant difference between in-class and semi-independent online course (Methods 1 and 2), where in-class method is showing higher academic achievement results. The research hypothesis is accepted within these two methods.
2. There was a significant difference between semi-independent, online course and the independent CD-ROM-based course (Methods 2 and 3). In this case the independent method has shown to be more effective than the online method. The research hypothesis is accepted within these two methods.
3. There was no statistically significant difference between the in-class and the independent CD-ROM methods (Methods 1 and 3). In this case, the research hypothesis is rejected within these two methods.

*Hypothesis 3*

*There is a correlation between the cognitive profiles of the students and academic achievement results among adult Continuing Education population learning Computer Aided Design.*

Using the results of the analysis (Pearson's coefficient of  $r = -.085$ , and Spearman's (Rho) coefficient of  $0.013$ ), it was established that no correlation existed

between the academic achievement and learning styles of the students. The research hypothesis was rejected. Therefore, these results indicate that overall academic achievement within the subject of Computer Aided Design are equal for all of the four cognitive profile categories, allowing people with different learning styles to achieve their desired levels of academic success, as well as to meet their educational goals.

As is discussed further in Chapter 5, the results of this study clearly indicated that the use of alternative educational delivery methods was an effective means to expand the philosophy of distance learning and the further applications of modern technological advancements. However, these results also raised a number of pertinent questions regarding the further applications of these methods for other, related, but not widely explored disciplines. Discussion of these questions, implications, and recommendations for further investigation, are discussed in Chapter 5.

## Chapter 5

### Conclusion, Implications, Recommendations, and Summary

#### Conclusion

Although many studies have focused on the use of distance learning as well as CD-ROM based instructional methodologies and its applicability to a variety of disciplines, very few scientific studies currently exist regarding the use of alternate learning methods in the area of Computer Aided Design in its broad variety of topics, spanning from basic drafting to advanced architecture and inter-galactic spacecraft design.

This study was undertaken to determine the efficacy of these alternative learning methods as compared to a traditional (in-class) method. The two additional methods examined were the following:

1. The method of semi-independent online learning, where students studied independently from home, but with access to the instructor via the phone or e-mail communications. This allowed students to ask any specific questions, receive all prescribed curriculum assignments and testing requirements.
2. The method of completely independent learning, using a CD-ROM based course. In this case the students were not able to communicate with the instructor, but rather had to complete the entire course using only the information provided on the CD.



The specific research questions examined were:

1. Are there any significant differences in objective course satisfaction, among the three methods used, among adult Continuing Education students learning Computer Aided Design?
2. Are there any significant differences in academic achievement, among the three methods used, among adult Continuing Education students learning Computer Aided Design?
3. Does a correlation exist between the cognitive profiles of the students and academic achievement results, among adult Continuing Education students learning Computer Aided Design?

Based on a review of relevant literature and the research questions, the following hypotheses were developed:

***Hypothesis 1:***

There is a significant difference in objective course satisfaction among the three methods of instruction among adult Continuing Education students learning Computer Aided Design.

***Hypothesis 2:***

There is a significant difference in academic achievement among the three methods of instruction among adult Continuing Education students learning Computer Aided Design.

***Hypothesis 3:***

There is a correlation between the cognitive profiles (as pertaining to learning styles) of the students, and academic achievement results among adult Continuing Education population learning Computer Aided Design.

In order to test these hypotheses, adult students were selected from a pool of volunteer participants interested in pursuing their careers directly in or associated with the discipline of Computer Aided Design (CAD). Three groups of adult students (ages 30-50) were randomly selected from the two sources: first, registered Continuing Education students at Kean University; located in Union, NJ, second, students drawn from the local New Jersey manufacturing, design, and architectural companies. Each of the three groups of students (one control, and two treatment groups) were required to complete a 2-months Computer Aided Design course presented in one of three instructional delivery methods:

1. ***In-Class Method (Control Group)***

The students had completed all of the prescribed course content using traditional classroom training, with the professor presenting the prescribed material and being available to help students in person at any time during the course.

2. ***Asynchronous, Internet-based course (Treatment Group I)*** All of the prescribed material was learned off-campus, and was facilitated by the professor via an asynchronous, Internet-based course (See Appendix K). The

students were required to communicate with the instructor on a daily basis (Monday – Friday) to receive new information and complete the required material within agreed time frames. The communications were conducted via the Internet-based communication forum, specifically dedicated to the study.

3. ***Independent, CD-ROM based course (Treatment Group II)***

All of the curriculum material was learned by a completely independent study using a well-recognized Autodesk-certified instructional tutorial on a CD-ROM.

Prior to participation of the study, all of the students were randomly assigned to one of the three groups described above. At that time, each student received a unique identification number (1-60). Thus, after random selection, the students in the first group were numbered 1 through 20, students in the second group were numbered 21 through 40, and the students in the third group were numbered 41 through 60. These unique numbers later allowed specific statistical analyses as pertains to each individual student. Following this, all students were required to complete a Cognitive Profile Inventory, specifically selected to analyze the learning profiles of the studied population. Students in each group received detailed preliminary instructions on how to utilize the computer technology (i.e. online communication forum, work-in-progress submission, faculty phone numbers and availability, etc). The experiment involving all three groups took place simultaneously for two months during the Spring Semester of 2005, under the direction of CIDM (Computer Integrated Design & Manufacturing) faculty, within the Department of Technology at Kean University. At the conclusion of the study, students in all groups were required to

complete the Student Satisfaction Inventory as well as complete the Autocad Achievement Examination.

The first hypothesis, examining the objective course satisfaction, was tested by means of an independent t-test, comparing the means and standard deviation among the three groups. Analysis of Variance (ANOVA) was then performed to test the significance ( $p$ ) value within the groups. The statistically significant difference was not found, and the original hypothesis was rejected.

The second hypothesis examined the academic achievement of the three tested groups of students. The results were also analyzed using the t-test that compared the test results of each group. As in the first case, an Analysis of Variance was also performed. However, the results were mixed. As stated earlier, the results of the academic achievement statistics had conclusively shown that a significant difference does exist between in-class and semi-independent online course (Methods I and II), where in-class method is showing higher academic achievement results. There is also a statistically significant difference between semi-independent, online course and the independent CD-ROM-based course (Methods II and III). In this case the independent method has shown to be more effective than the online method. There was no statistically significant difference, between the in-class and the independent CD-ROM methods (Methods I and III). The original hypothesis was accepted for the first two instances and rejected for the third.

The third hypothesis examined the cognitive profiles of the studied population. All of the students in the three groups completed a Cognitive Profile Inventory (Krause, 2000). As briefly mentioned in Chapter 1, the Cognitive Profile Inventory consisted of 60

pairs of questions. The quantitative results were obtained and graphically plotted for each student. From the obtained data, it was concluded that the majority of the students used in the experiment (25 students or 42%) would fit within the Intuitive-Thinker category; 19 students (32%) fit within Sensor-Thinker category, and 8 students (13%) fit within each of the two remaining categories. This further supports the data obtained in the variety of technical disciplines in past research (Krause, 2000). Additionally, as part of the original hypothesis #3, the correlation was examined between these cognitive profile matrices and the academic achievement results (actual test grades). The statistical results had conclusively shown that no correlation exist between these two variables, therefore rejecting the original research hypothesis.

### **Implications**

The findings in this study failed to support definite conclusions regarding which of the three methods of instruction employed in this study is most effective in enhancing the achievement gains of subjects studying Computer Aided Design. The results of this study did, however, suggest that any of the three methods of instruction is as effective as the other in teaching the CAD concepts. The expected gains of achievement to be made by any of the three methods did not materialize. However, all of the methods employed, being almost equal in its efficiency, prove a very important and valuable point. Distance learning, in all of its aspects, is growing at an overwhelming rate worldwide. There is hardly any college or university in the world today that does not offer some type of external Continuing Education or degree program. The ability to learn Computer Aided Design, being just as effective online or on CD-ROM, as In-class, as concluded by the

results of this study, opens many opportunities for technology specialists from all over the world. Unfortunately, in many countries the ability to attend a traditional class in a local school or a college simply does not exist. Changing economic conditions, political climates, military and religious upheavals in many parts of the world prevent an alarming number of people from learning the subjects they desire. Distance learning, in all of its numerous aspects, offers these people hope for a brighter future, as well as the ability to choose from a broader variety of disciplines, instructors, and learning styles to accommodate their individual situations. As video and computerized training becomes more available and accessible by more people, many more disciplines are now available that previously were much harder to learn over distance using traditional books and/or other “hard copy” study aids.

It is also worth noting that the Autocad program, being at the forefront of the long list of Computer Aided Design technology, represents a “prototype” of CAD learning in general. Yet to be confirmed by individual experimental research, it is an opinion of the author of this study that the obtained results may closely, if not equally, apply to a whole variety of other leading and very popular relevant CAD software programs such as:

- Solidworks
- Pro-Engineer / Wildfire Parametric
- Autodesk Inventor
- Rhinoceros Design
- Alibre Design
- Design CAD
- MasterCAM /CAD

The above list represents only a small portion of a long list of other programs related to modern engineering, architecture, graphic design, and manufacturing

technology. These disciplines may share a very similar population cross-section, as well as age breakdown employed in this study.

### **Recommendations for Future Research**

In recent years, due to the significant advances of capabilities of modern computer systems, there exists an array of disciplines closely associated with CAD. Some of these disciplines are:

- Computer Animation
- Computerized Accident Reconstruction
- Architectural & Construction Design
- Cost Estimating & Value Analysis
- Animated Medical Illustration
- Stress and Finite Element Analysis
- Computerized Mathematical Modeling
- Animated Biology and Neurology Modeling
- Computerized Nuclear Physics
- Web and Graphic Design
- Molecular Biology Modeling

Since many of these subjects are fairly new, alternate methods of educational delivery have not been thoroughly explored. Future research could focus on the use of the Internet as well as independent CBT (Computer Based Training) as a total replacement or as a viable supplement of classroom-based certification. This would be especially useful in determining the long-term effectiveness of computer-based training in the technology / engineering community. Other areas of interest may be a study by corporations, analyzing ROI (Return on Investment) that computer-based instruction offers. In these

times, when qualified professional technical jobs are not as readily available as in the past, perhaps many companies would consider, if a cost-effective alternative exists, retraining their employees rather than re-hiring.

Additionally, the findings of this study have raised questions which can be answered only by further research. Some of these questions are as follows:

1. Would a similar study in other subject matter areas produce the same results?
2. Would simulation technical computer-based laboratory experiments be as effective as traditional “hands-on” laboratory experiments?
3. Would online or CD-ROM based training improve the short and long-term retention of learned material for technology students?
4. To what extent would Computer-Based instruction reduce the time it takes for students to gain a solid working knowledge of many technology and engineering disciplines?
5. Would students who are required to study independently, gain a better sense of learning discipline, and as a result of that become better, more organized specialists in their fields?
6. Based on much existing research, there are a significant number of women pursuing careers in the various aspects of technology, at this point it is mostly in technical areas of Medical and fashion related industries, as well as number of others. However, most branches of engineering and manufacturing are still primarily male (at least based on my observation of technology and engineering students in New Jersey.). The Architectural field, however, is drawing a larger number of women for the past 5 years or so, and most of it in the areas of Interior



Design. It is definitely a great topic for further research, especially in CAD where not much current reach is available.

### **Summary**

The research presented in this study, identified an important aspect of modern applications of Computer Aided Design (CAD) education: Adult Continuing Education (CE) students (ages 30-50), pursuing a career in computer integrated technologies learn just as effectively using modern technology such as the Internet, and CD-ROM based training as they would learn in a traditional, classroom setting. Building on the foundation of existing evidence in multiple instruction delivery methodologies applied to adult education, the study had compared three methods of instructional delivery to determine if the online and CD-ROM based training will be as effective as the traditional classroom-based course. The experimental design has consisted of three randomly selected sample groups. Each group contained 20 adult CE students 30-50 years of age. The independent variable in the study was the instructional method. The dependent variables were the academic achievement scores and the satisfaction levels of the participants. Of the three groups of adult Continuing Education students, Group 1 received the traditional classroom training (control group), Group 2 received an online course (treatment group 1), and Group 3 was trained independently, using a CD-ROM-based course (treatment group 2). Data was gathered regarding the achievement scores and participant satisfaction levels of all three groups.

One of the major goals of this research was to help improve the traditional educational process by analyzing effectiveness of multiple educational models pertinent

to one specific technical discipline common to all areas of modern engineering and technology – Computer Aided Design. It became quite evident that all three methods were sufficiently effective, as far as the final achievement grades and satisfaction levels of the students, to learn the subject of Computer Aided Design. Of course, the quality of instruction, regardless of the delivery method, is the core of any successful learning. It may very well be assumed that a poorly developed online course may not even compare to a well developed in-class or CD-Rom based course, or vice-versa. After all, it is always a living, human instructor who presents the material, be it online or through any other delivery media. Educators worldwide should continue thriving towards constant improvement of the quality of the curriculum, as well as improving the educational delivery of the material itself (i.e. make the presentation more comprehensible and retainable for average student). As this research has shown, a well developed course, regardless of the method used, allowed students who were not familiar with computer aided technology to improve their careers and get closer to their academic or professional goals. As a final point, statistical findings revealed several important variables (i.e. course satisfaction, academic achievement, and cognitive profiles of the students) that helped in predicting the likelihood of enrolling in future independent or Web-based courses. These key variables should continue to be the focus of future studies in the area of Distance Learning and Andragogy.

## Appendix A

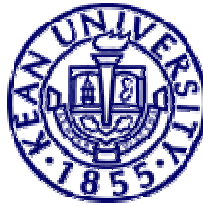

**Kean University**  
1000 Morris Avenue  
Union, New Jersey 07083

# **Computer Aided Design, Level I AutoCAD<sup>®</sup> Achievement Examination**

In accordance with Autodesk<sup>®</sup> Standard Assessment Examination  
2003-2005

Continuing Professional Education  
Advanced Computer Technology Center ACTC  
Nathan Weiss College of Graduate Studies

Copyright © Kean University  
2005



**Kean University**  
1000 Morris Avenue  
Union, New Jersey 07083

## AutoCAD® Achievement Examination

Continuing Professional Education  
Advanced Computer Technology Center ACTC  
Nathan Weiss College of Graduate Studies

### Question1

To crosshatch the shape below, which point (or combination of points) were selected on the drawing?

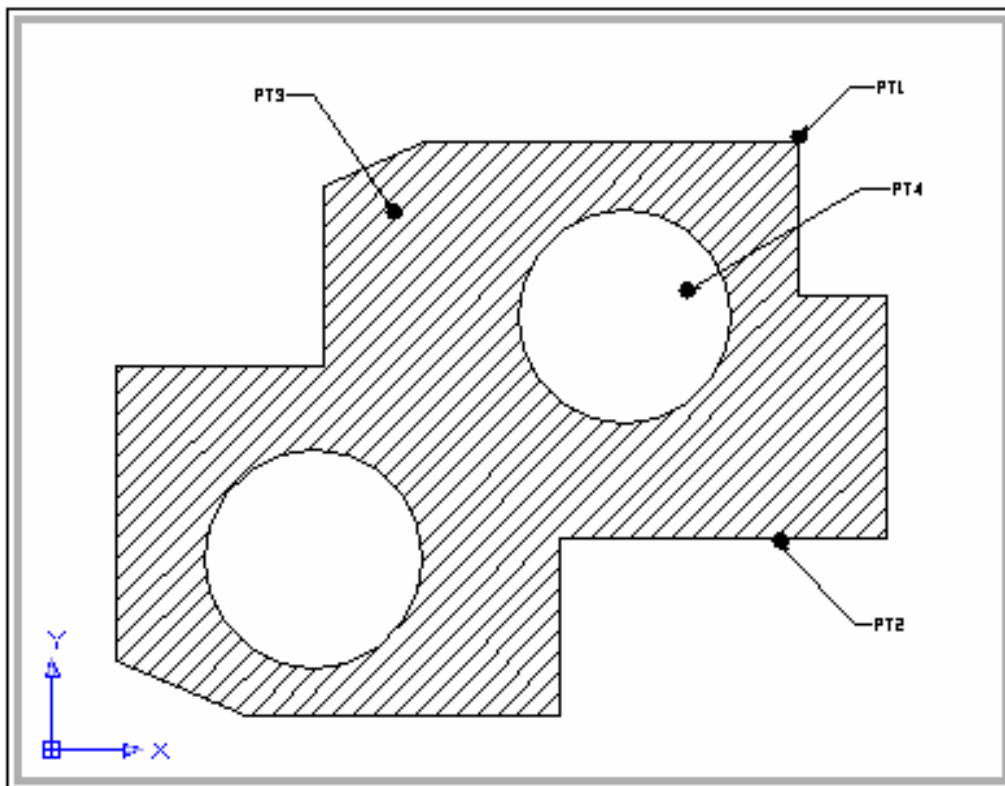

- A  Pt 1
- B  Pt 2
- C  Pt 3
- D  Pt 4



**Kean University**  
1000 Morris Avenue  
Union, New Jersey 07083

## AutoCAD® Achievement Examination

Continuing Professional Education  
Advanced Computer Technology Center ACTC  
Nathan Weiss College of Graduate Studies

### Question 2

To create LINE 1 shown below in the quickest possible way, which command would you use?

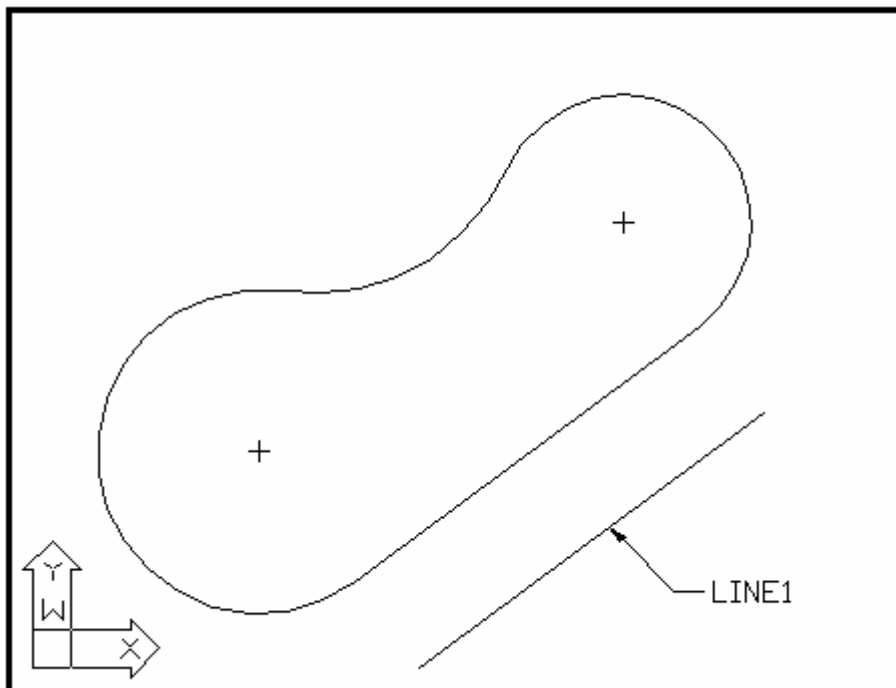

- A  Copy
- B  Parallel
- C  Offset
- D  Move



**Kean University**  
1000 Morris Avenue  
Union, New Jersey 07083

## AutoCAD® Achievement Examination

Continuing Professional Education  
Advanced Computer Technology Center ACTC  
Nathan Weiss College of Graduate Studies

### Question 3

Describe the name of the Toolbar Menu Item 1

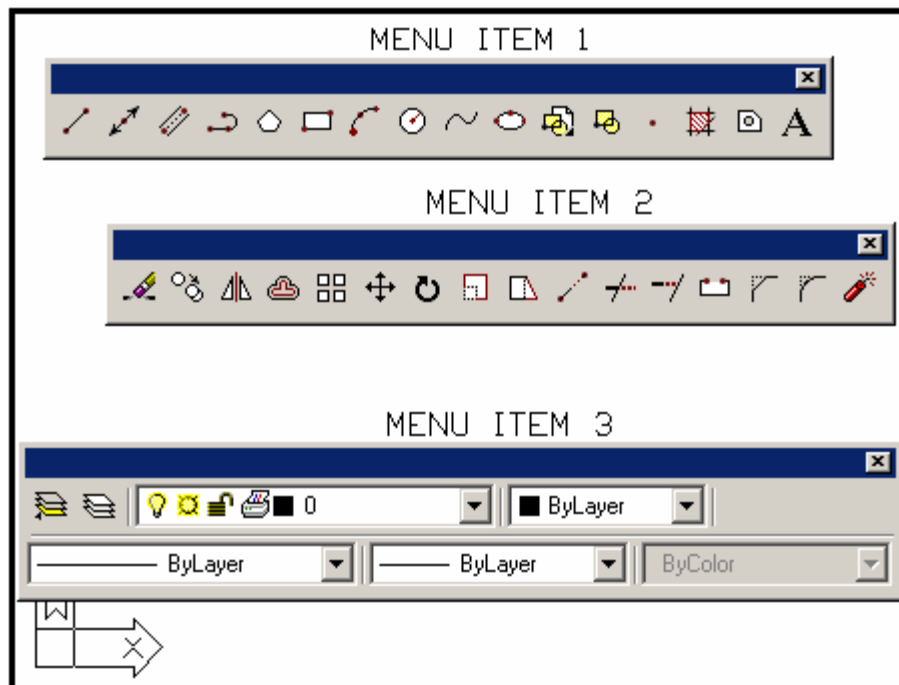

- A  Edit
- B  Modify
- C  Draw
- D  Object Properties



**Kean University**  
1000 Morris Avenue  
Union, New Jersey 07083

## AutoCAD® Achievement Examination

Continuing Professional Education  
Advanced Computer Technology Center ACTC  
Nathan Weiss College of Graduate Studies

### Question 4

Which command would you use to create the larger diameter circle, shown below, located 1.00" apart from the smaller one?

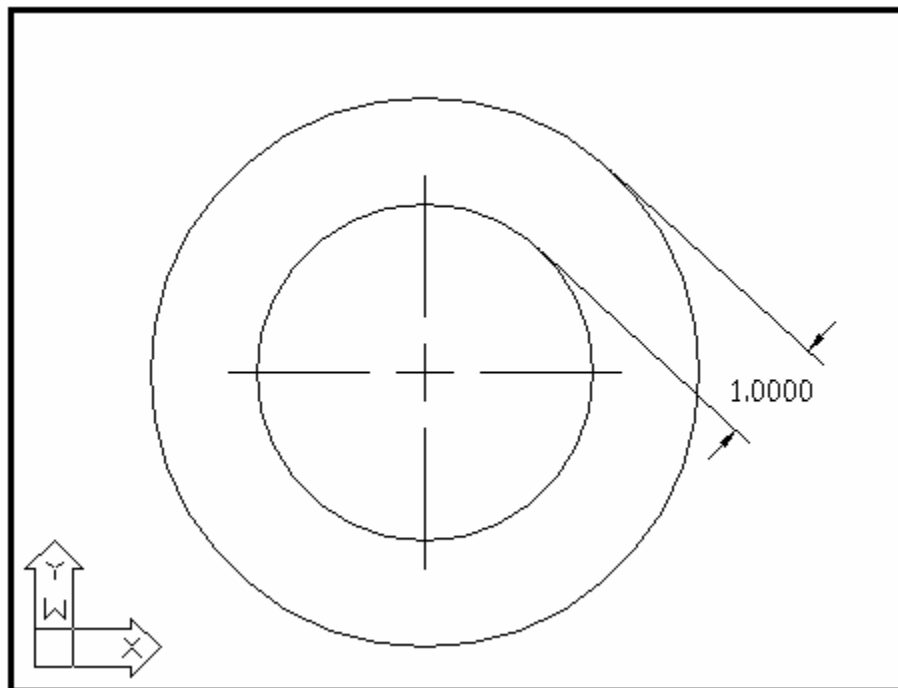

- A  Offset
- B  Copy
- C  Parallel
- D  Basic



**Kean University**  
1000 Morris Avenue  
Union, New Jersey 07083

## AutoCAD® Achievement Examination

Continuing Professional Education  
Advanced Computer Technology Center ACTC  
Nathan Weiss College of Graduate Studies

### Question 5

To eliminate segments 1 and 2 from the drawing, leaving the segment inside the circle intact, which procedure would you use?

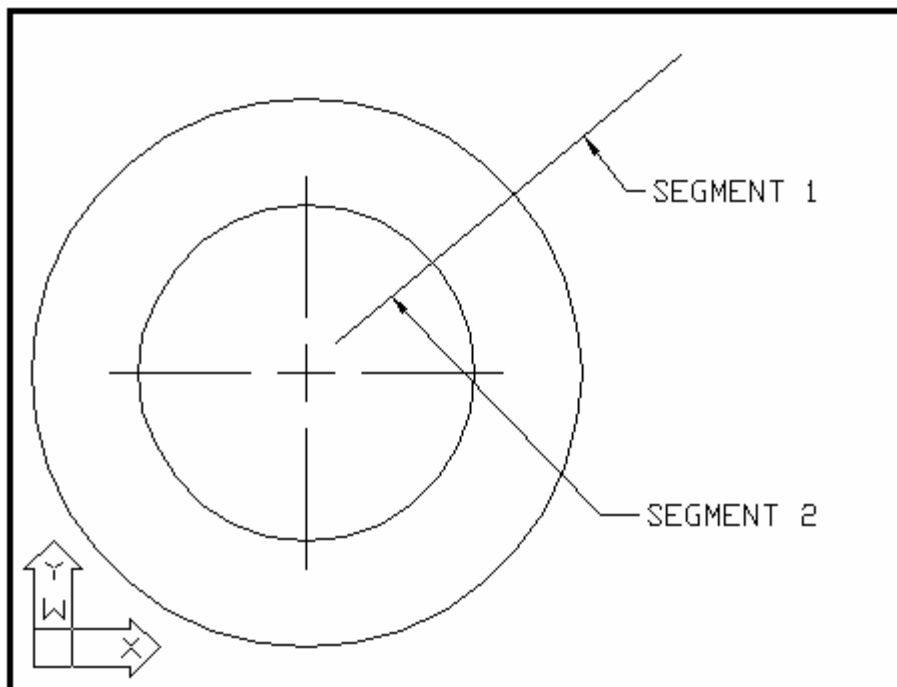

- A  Cut
- B  Trim
- C  Erase
- D  Delete





**Kean University**  
1000 Morris Avenue  
Union, New Jersey 07083

## AutoCAD® Achievement Examination

Continuing Professional Education  
Advanced Computer Technology Center ACTC  
Nathan Weiss College of Graduate Studies

### Question 6

To dimension Item 1 on the drawing below, which dimensioning command would you most commonly choose?

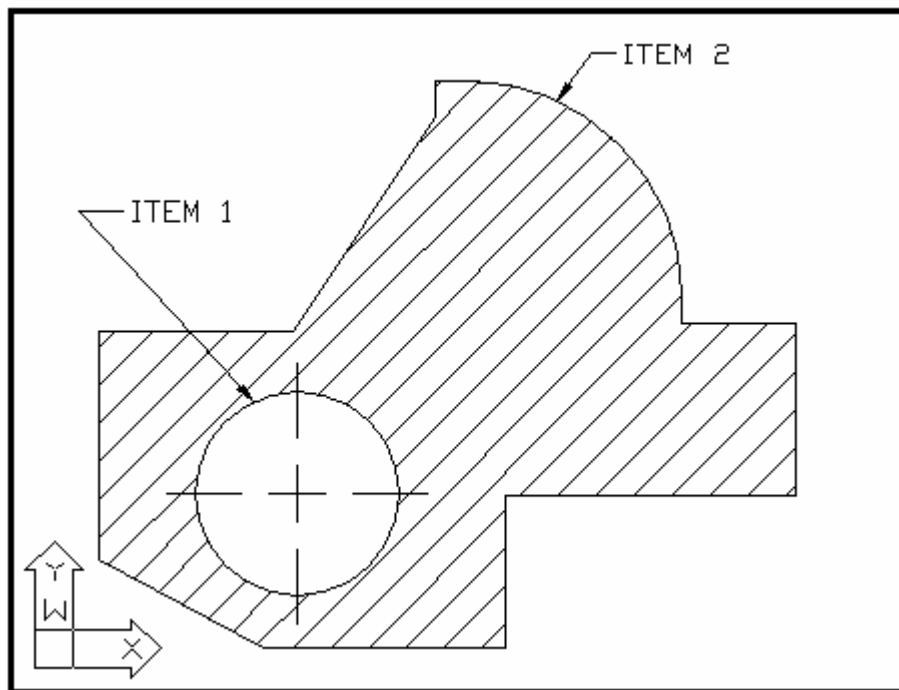

- A  Diameter
- B  Radius
- C  Circle
- D  Arc



**Kean University**  
1000 Morris Avenue  
Union, New Jersey 07083

## AutoCAD® Achievement Examination

Continuing Professional Education  
Advanced Computer Technology Center ACTC  
Nathan Weiss College of Graduate Studies

---

### Question 7

To quickly connect four lines shown below, obtaining a rectangular shape with sharp corners, which command would you execute?

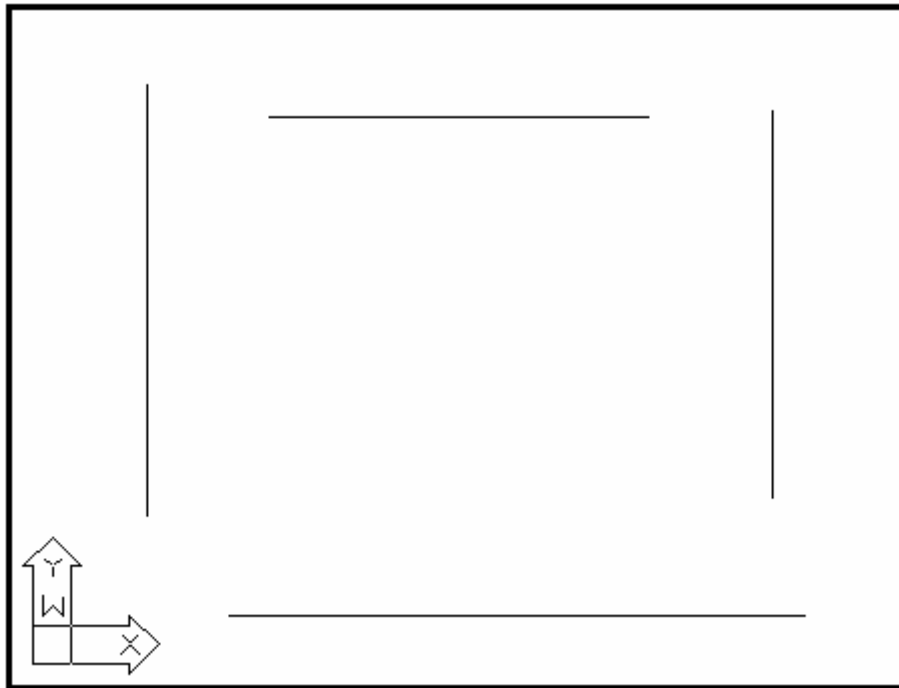

- A  Close
  - B  Fillet with 0 Radius
  - C  Delete
  - D  Arc
-



**Kean University**  
1000 Morris Avenue  
Union, New Jersey 07083

## AutoCAD® Achievement Examination

Continuing Professional Education  
Advanced Computer Technology Center ACTC  
Nathan Weiss College of Graduate Studies

### Question 8

To dimension Item 2 on the drawing below, which dimensioning command would you most commonly choose?

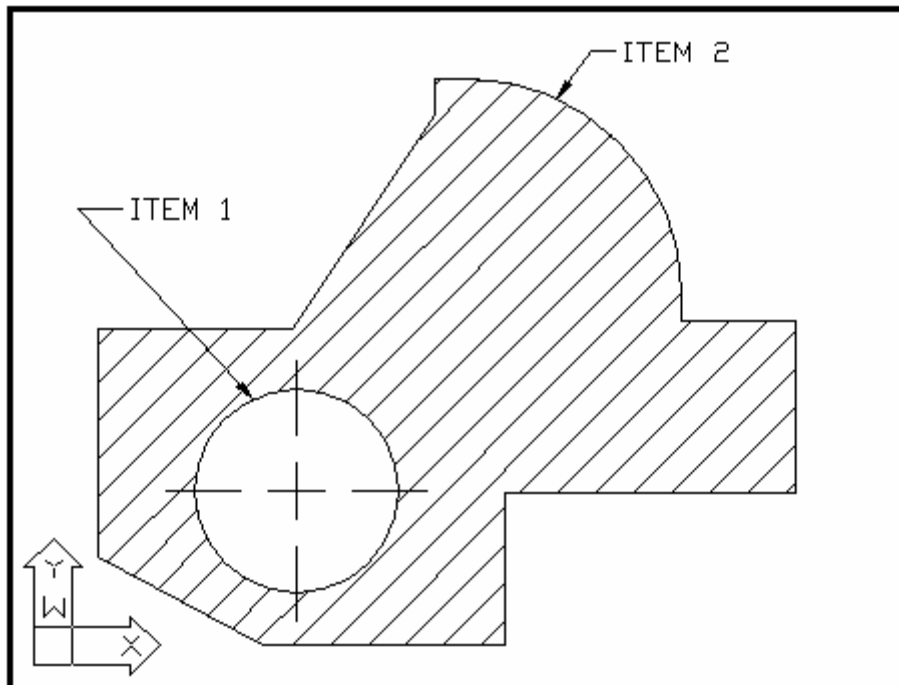

- A  Diameter
- B  Radius
- C  Circle
- D  Arc



**Kean University**  
1000 Morris Avenue  
Union, New Jersey 07083

## AutoCAD® Achievement Examination

Continuing Professional Education  
Advanced Computer Technology Center ACTC  
Nathan Weiss College of Graduate Studies

### Question 9

To produce the corner as shown on the drawing below, which command would be most useful?

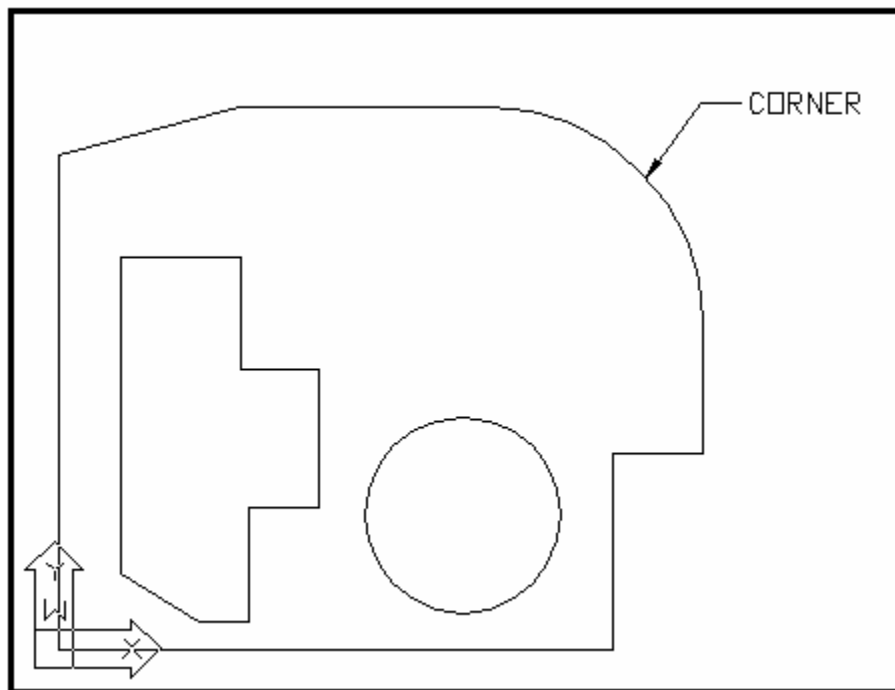

- A  Chamfer
- B  Radius
- C  Fillet
- D  Arc



**Kean University**  
1000 Morris Avenue  
Union, New Jersey 07083

## AutoCAD® Achievement Examination

Continuing Professional Education  
Advanced Computer Technology Center ACTC  
Nathan Weiss College of Graduate Studies

### Question 10

To produce the rectangle shown below, leaving all sharp corners, one of two most commonly used commands are likely to be used. Choose the set of two commands from the choices below.

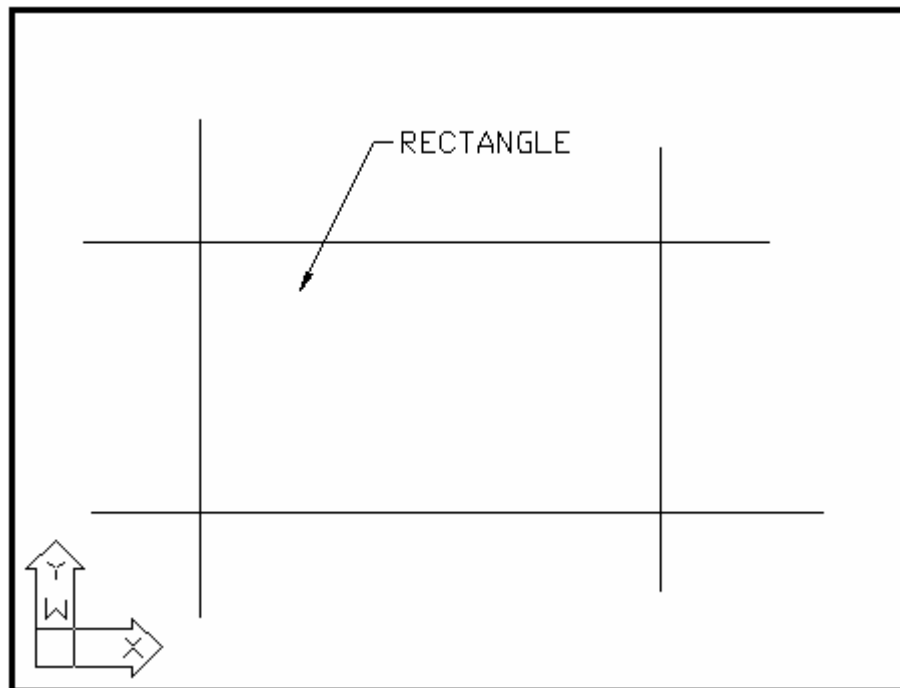

- A  Fillet or Trim
- B  Radius or Corner
- C  Solid or Surface
- D  Revolve or Extrude



**Kean University**  
1000 Morris Avenue  
Union, New Jersey 07083

## AutoCAD® Achievement Examination

Continuing Professional Education  
Advanced Computer Technology Center ACTC  
Nathan Weiss College of Graduate Studies

### Question 11

Which command from the Dimensioning menu produced all of the dimensions in the drawing below?

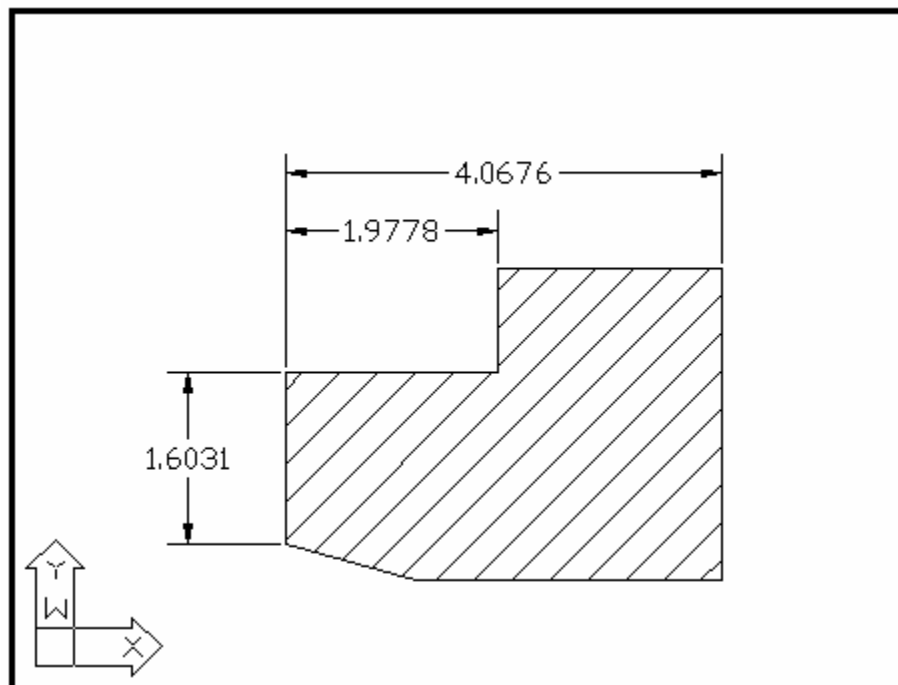

- A  Diameter
- B  Linear
- C  Aligned
- D  Center Mark



**Kean University**  
1000 Morris Avenue  
Union, New Jersey 07083

## AutoCAD® Achievement Examination

Continuing Professional Education  
Advanced Computer Technology Center ACTC  
Nathan Weiss College of Graduate Studies

### Question 12

Which command from the Dimensioning menu produced the 1.2584 dimension in the drawing below?

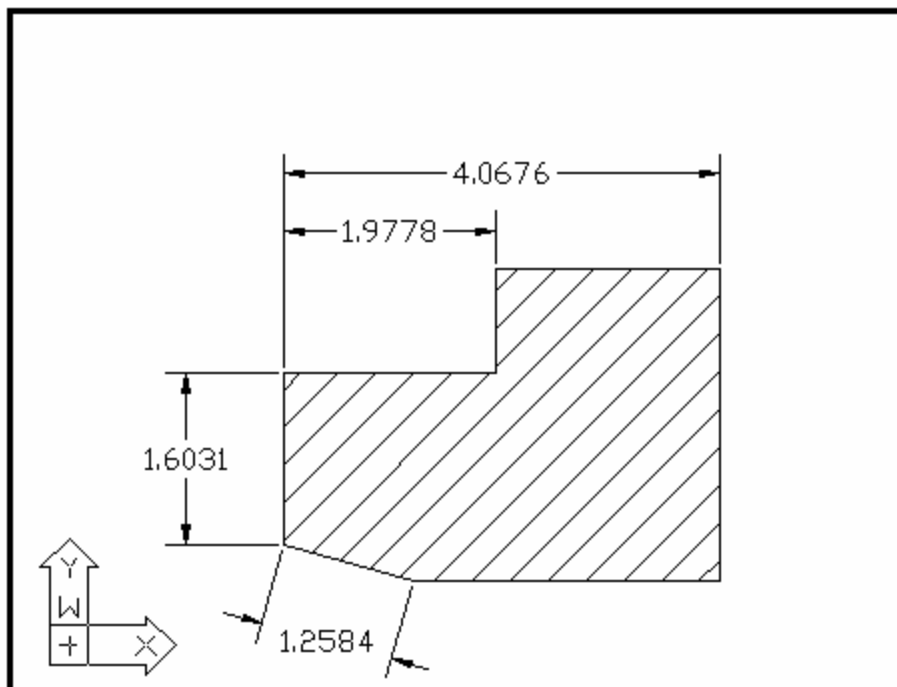

- A  Diameter
- B  Aligned
- C  Linear
- D  Center Mark

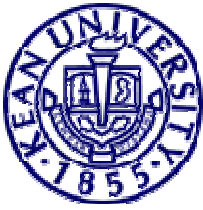

**Kean University**  
1000 Morris Avenue  
Union, New Jersey 07083

## AutoCAD® Achievement Examination

Continuing Professional Education  
Advanced Computer Technology Center ACTC  
Nathan Weiss College of Graduate Studies

### Question 13

In the drawing below which two entities were most likely drawn at the very beginning of the construction process?

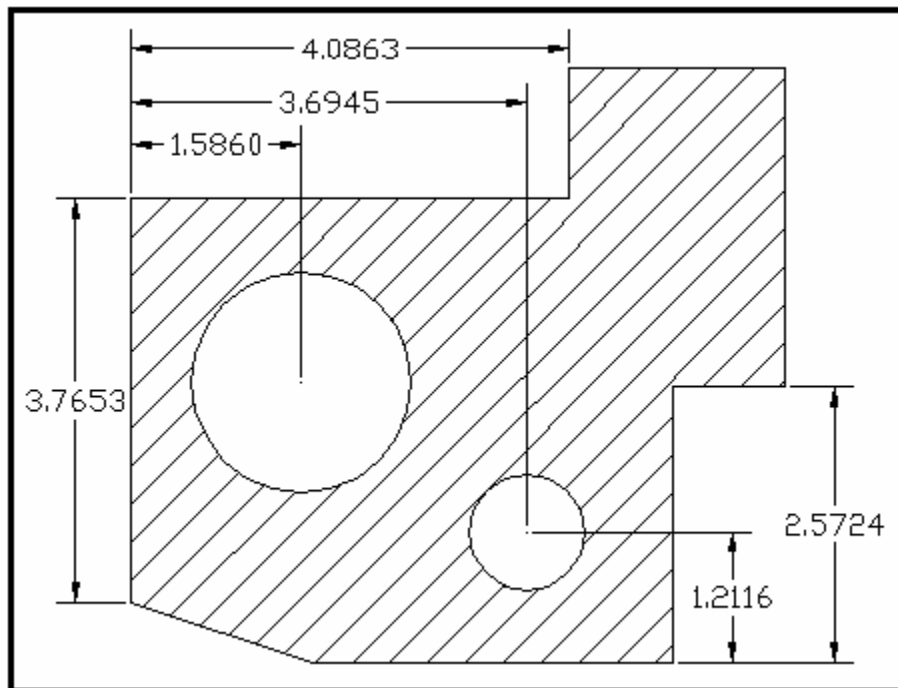

- A  Two corner lines
- B  A line and a circle
- C  Two parallel lines
- D  Crosshatch





**Kean University**  
1000 Morris Avenue  
Union, New Jersey 07083

## AutoCAD® Achievement Examination

Continuing Professional Education  
Advanced Computer Technology Center ACTC  
Nathan Weiss College of Graduate Studies

### Question 14

In the drawing below, Line 1 and Line 2 are connecting two external circles. What technique was used to produce the lines?

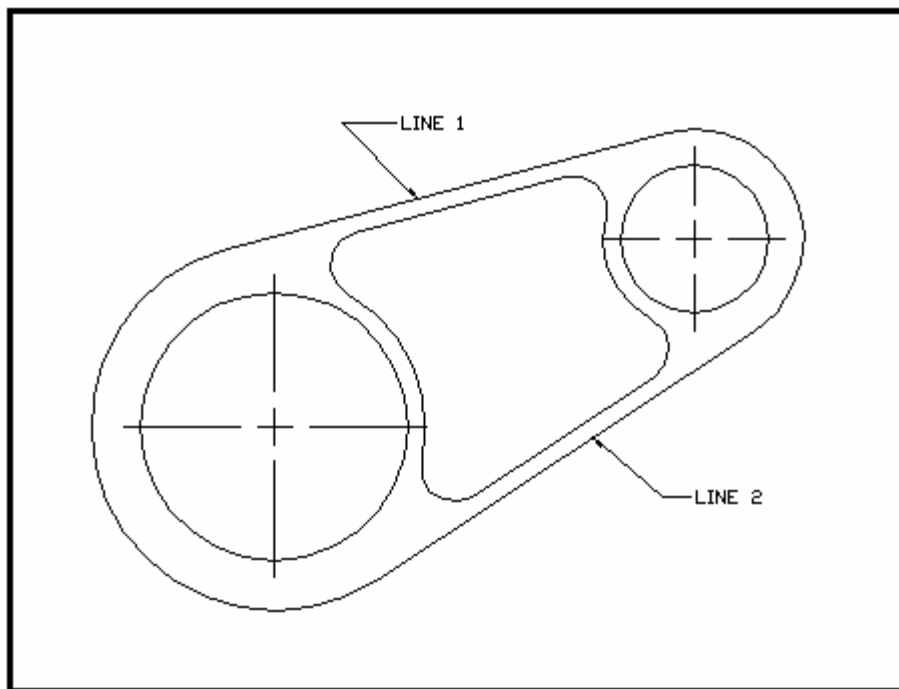

- A  Line, tangent to tangent
- B  A line and a circle
- C  Two parallel lines
- D  Line, parallel, circle



**Kean University**  
1000 Morris Avenue  
Union, New Jersey 07083

## AutoCAD® Achievement Examination

Continuing Professional Education  
Advanced Computer Technology Center ACTC  
Nathan Weiss College of Graduate Studies

### Question 15

The connecting arc shown below was drawn using which technique?

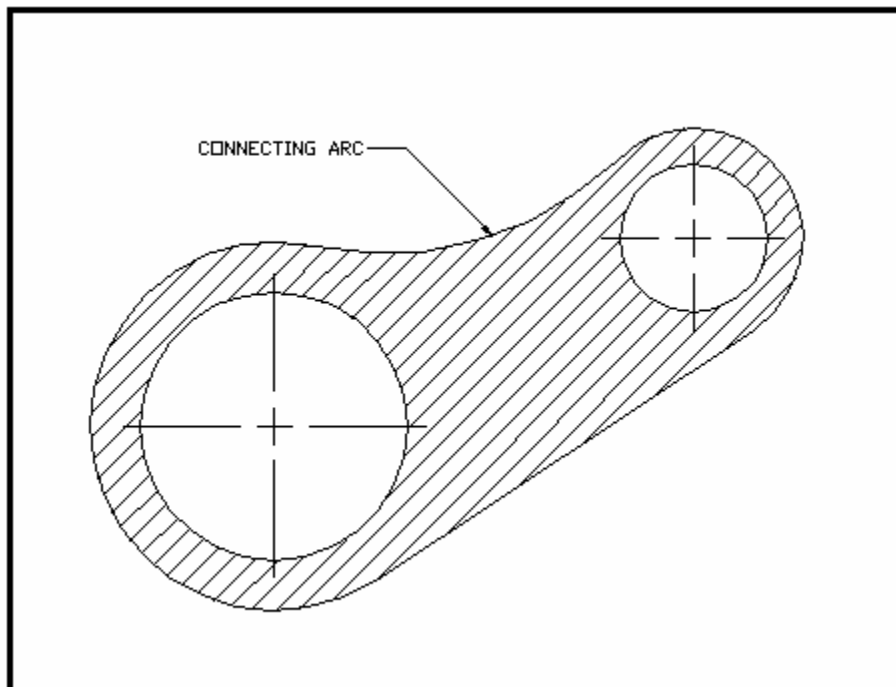

- A  Circle, TTR
- B  Line, parallel
- C  Crosshatch
- D  Line, TTR



**Kean University**  
1000 Morris Avenue  
Union, New Jersey 07083

## AutoCAD® Achievement Examination

Continuing Professional Education  
Advanced Computer Technology Center ACTC  
Nathan Weiss College of Graduate Studies

### Question 16

To produce angular dimension below, and the line being 5.0" long, which sequence had to be typed at the command prompt?

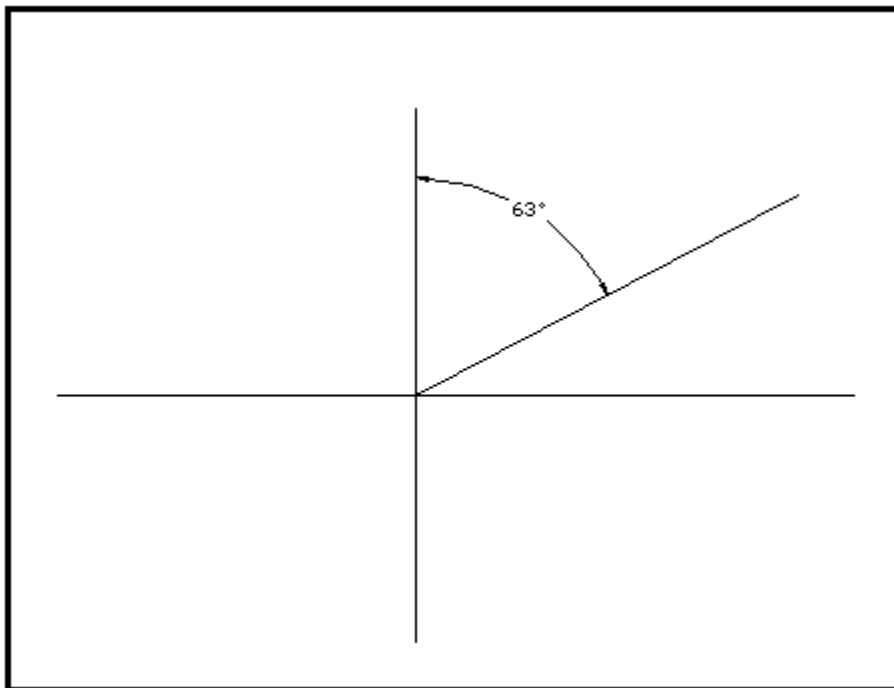

- A  @ 5 < 122 Enter
- B  5 < 27 Enter
- C  5 < 210 Enter
- D  @ 5 < 27 Enter



**Kean University**  
1000 Morris Avenue  
Union, New Jersey 07083

## AutoCAD® Achievement Examination

Continuing Professional Education  
Advanced Computer Technology Center ACTC  
Nathan Weiss College of Graduate Studies

### Question 17

In order to produce a hexagon drawn below which technique within the polygon command was most likely to be used?

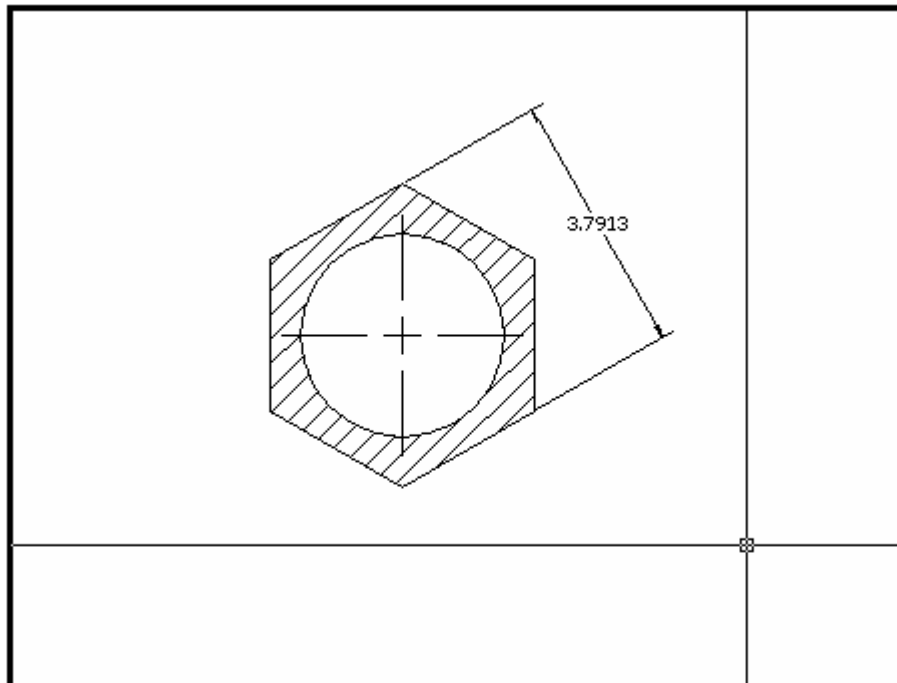

- A  Circle, Circumscribed
- B  Polygon, Inscribed
- C  Nuts and Bolts
- D  Octagon, Inscribed



**Kean University**  
1000 Morris Avenue  
Union, New Jersey 07083

## AutoCAD® Achievement Examination

Continuing Professional Education  
Advanced Computer Technology Center ACTC  
Nathan Weiss College of Graduate Studies

### Question 18

In the drawing below, which of the indicated points is the best origin point of the entire drawing?

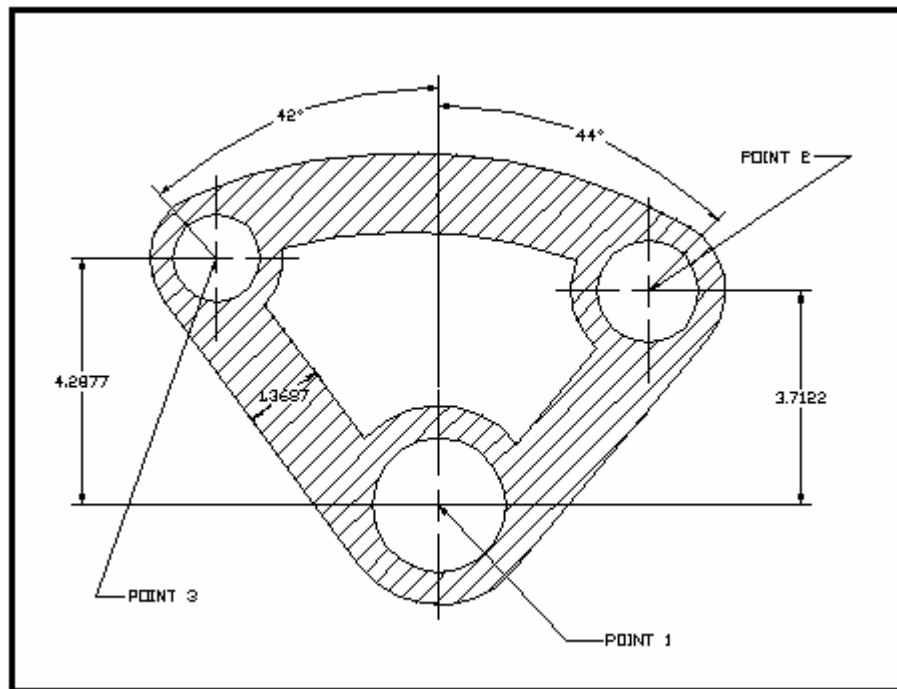

- A  Point 2
- B  Point 1
- C  Point 3
- D  None of the above



**Kean University**  
1000 Morris Avenue  
Union, New Jersey 07083

## AutoCAD® Achievement Examination

Continuing Professional Education  
Advanced Computer Technology Center ACTC  
Nathan Weiss College of Graduate Studies

### Question 19

Please indicate which dimensions (if any) are missing from the drawing below. Select from the available choices.

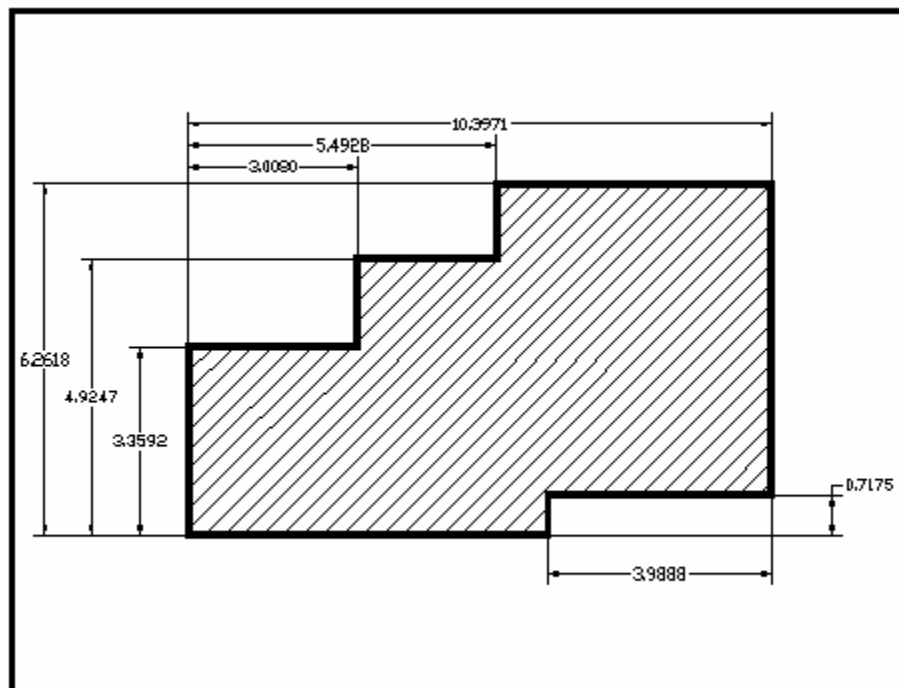

- A  One vertical dimension
- B  Three horizontal dimensions
- C  All required dimensions are present
- D  Diameter Dimension



**Kean University**  
1000 Morris Avenue  
Union, New Jersey 07083

## AutoCAD® Achievement Examination

Continuing Professional Education  
Advanced Computer Technology Center ACTC  
Nathan Weiss College of Graduate Studies

### Question 20

Which of the drawing components (omitting text size) are not dimensioned according to the engineering ANSI standards? Select from the choices below.

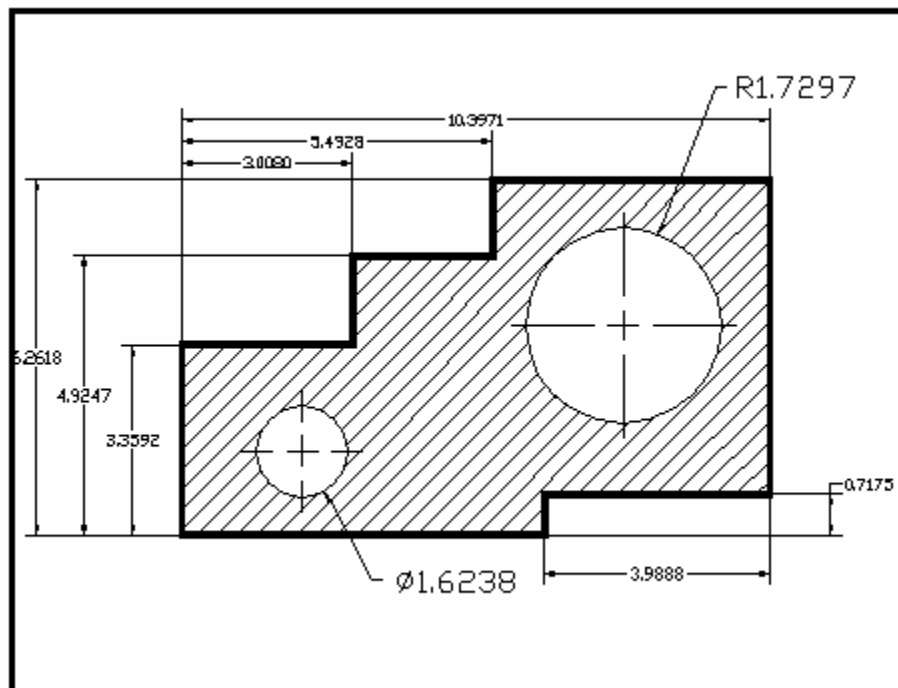

- A  Location of both circles
- B  Smaller circle diameter
- C  Crosshatch location
- D  Vertical dimensions

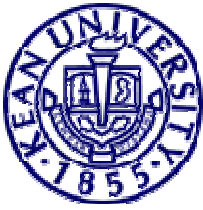

**Kean University**  
1000 Morris Avenue  
Union, New Jersey 07083

## AutoCAD® Achievement Examination

Continuing Professional Education  
Advanced Computer Technology Center ACTC  
Nathan Weiss College of Graduate Studies

### Question 21

What is the horizontal distance between point A and B. Choose the best answer from the selection below.

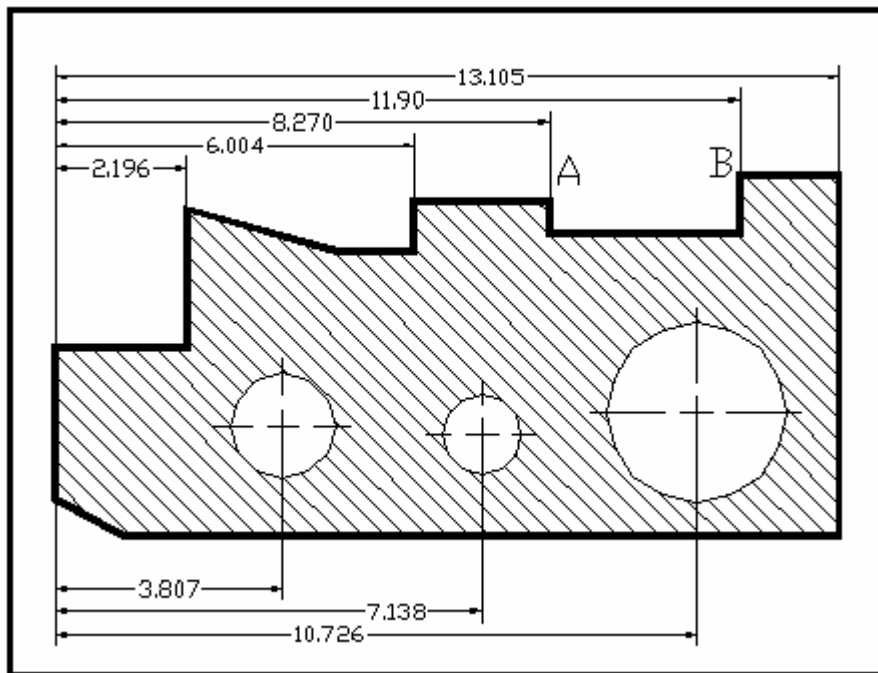

- A  3.63
- B  3.36
- C  5.12
- D  2.94





**Kean University**  
1000 Morris Avenue  
Union, New Jersey 07083

## AutoCAD® Achievement Examination

Continuing Professional Education  
Advanced Computer Technology Center ACTC  
Nathan Weiss College of Graduate Studies

### Question 22

Which procedure would be used to create a pattern of angular lines inside the triangle below?

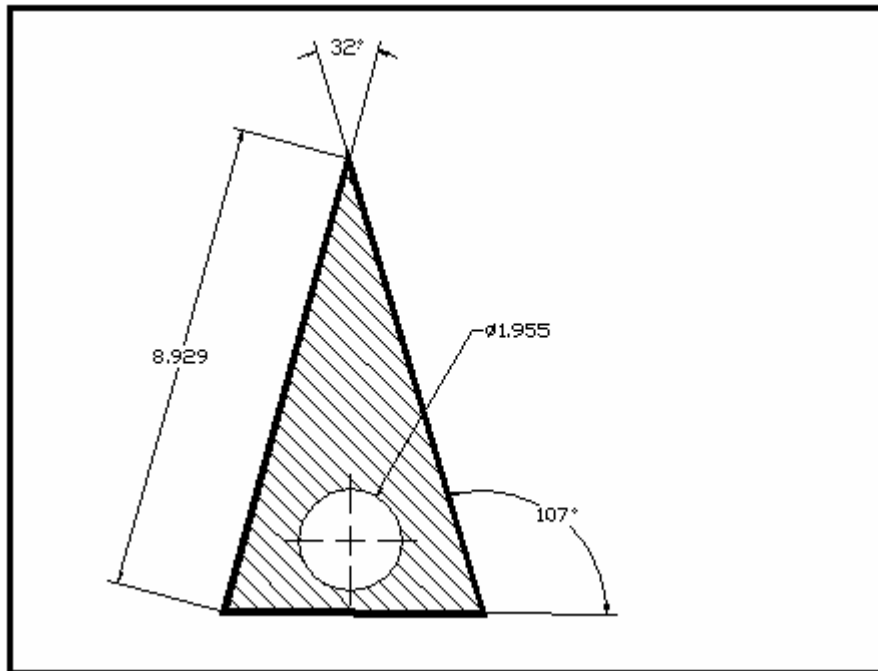

- A  Fill
- B  Series of individual 45 deg. lines
- C  An array of lines
- D  Cross-hatch



**Kean University**  
1000 Morris Avenue  
Union, New Jersey 07083

## AutoCAD® Achievement Examination

Continuing Professional Education  
Advanced Computer Technology Center ACTC  
Nathan Weiss College of Graduate Studies

### Question 23

Which one of the following dimensioning styles is most commonly used in dimensioning standard polygons?

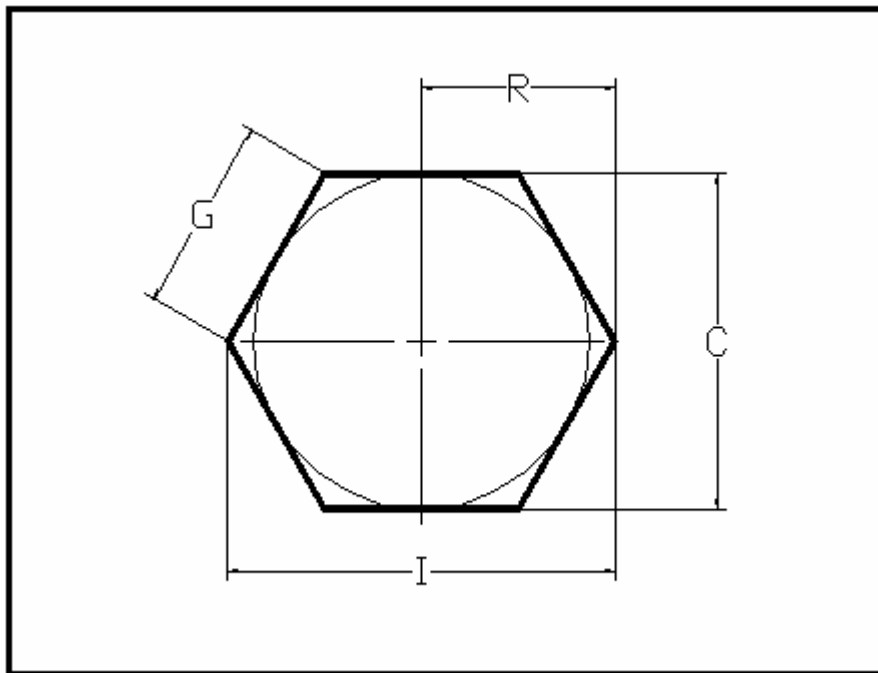

- A  Style "I"
- B  Style "C"
- C  Style "G"
- D  Style "R"



**Kean University**  
1000 Morris Avenue  
Union, New Jersey 07083

## AutoCAD® Achievement Examination

Continuing Professional Education  
Advanced Computer Technology Center ACTC  
Nathan Weiss College of Graduate Studies

### Question 24

Name the Toolbar Menu Item 2

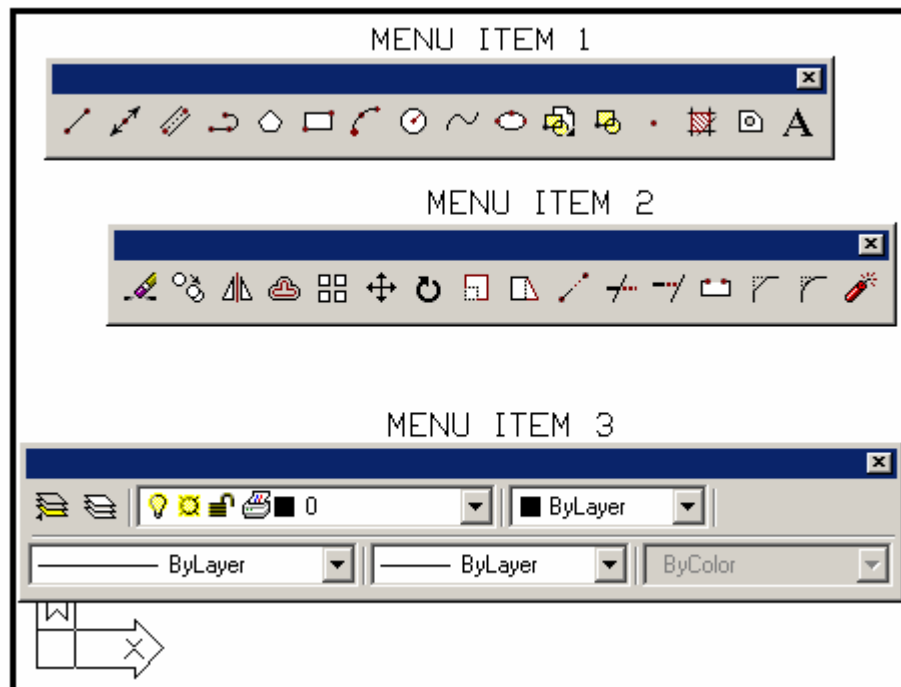

- A  Dimension
- B  Modify
- C  Draw
- D  Object properties



**Kean University**  
1000 Morris Avenue  
Union, New Jersey 07083

## AutoCAD® Achievement Examination

Continuing Professional Education  
Advanced Computer Technology Center ACTC  
Nathan Weiss College of Graduate Studies

### Question 25

Name the Toolbar Menu Item 3

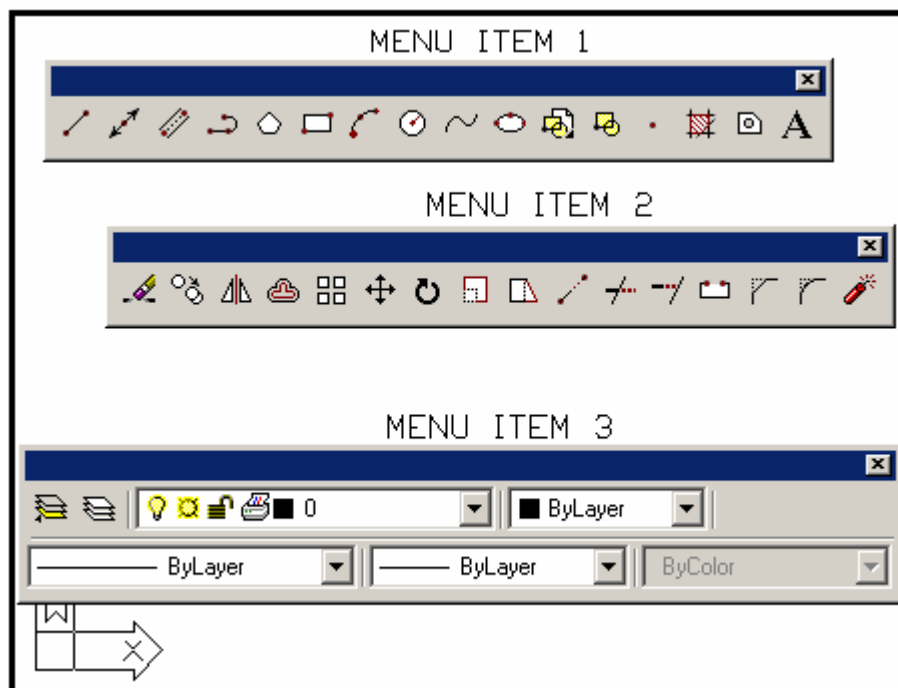

- A  Dimension
- B  Modify
- C  Draw
- D  Object properties



**Kean University**  
1000 Morris Avenue  
Union, New Jersey 07083

## AutoCAD® Achievement Examination

Continuing Professional Education  
Advanced Computer Technology Center ACTC  
Nathan Weiss College of Graduate Studies

### Question 26

You construct a plan layout of the bathroom illustrated below in figure A. What Modify command is best used to produce image B from image A?

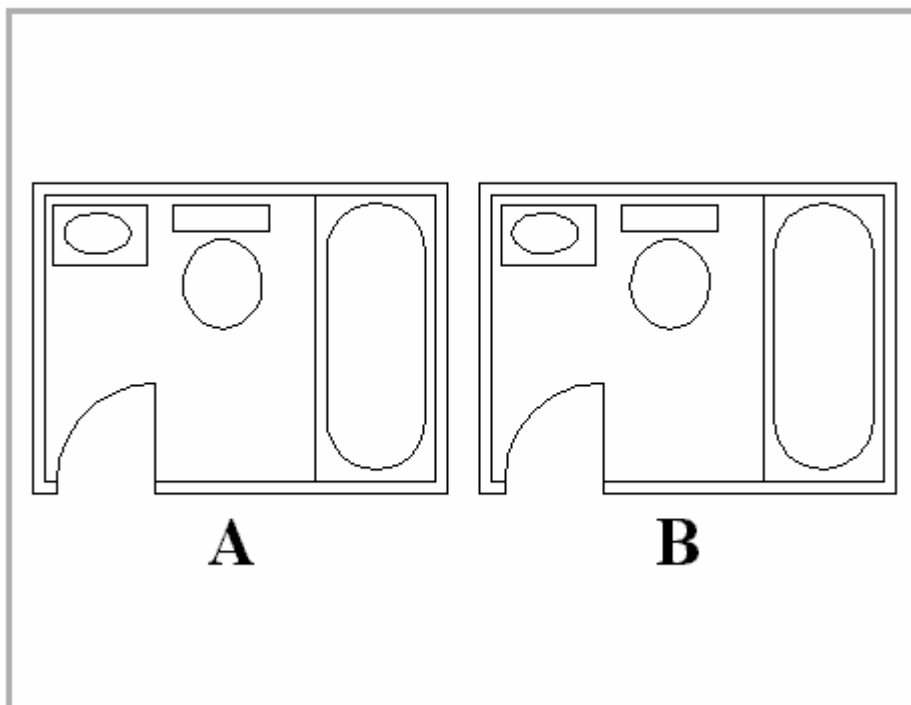

- A  Copy
- B  Stretch
- C  Mirror
- D  Move



**Kean University**  
1000 Morris Avenue  
Union, New Jersey 07083

## AutoCAD® Achievement Examination

Continuing Professional Education  
Advanced Computer Technology Center ACTC  
Nathan Weiss College of Graduate Studies

### Question 27

You construct a plan layout of the bathroom illustrated below in figure A. What Modify command is best used to produce image B from image A?

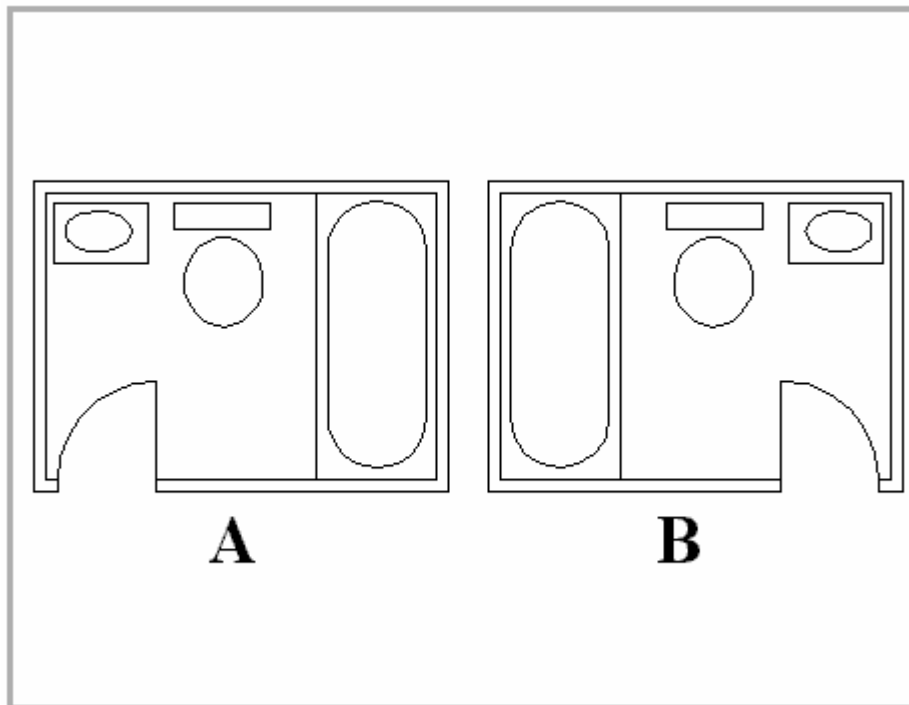

- A  Copy
- B  Change
- C  Mirror
- D  Move



**Kean University**  
1000 Morris Avenue  
Union, New Jersey 07083

## AutoCAD® Achievement Examination

Continuing Professional Education  
Advanced Computer Technology Center ACTC  
Nathan Weiss College of Graduate Studies

### Question 28

Which function key should be used to create lines perfectly straight?

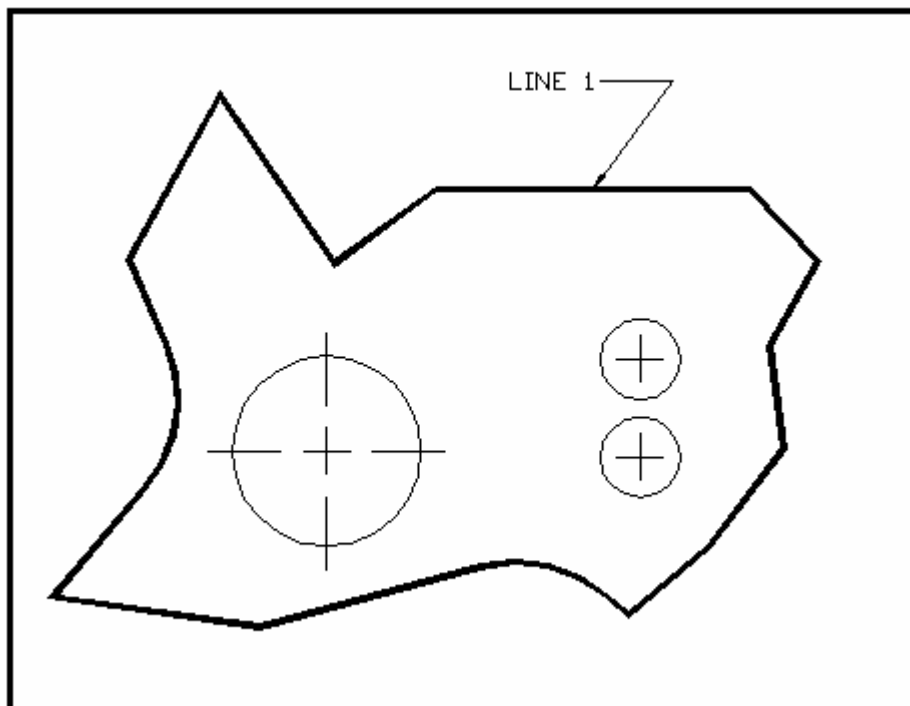

- A  F1
- B  F3
- C  F8
- D  F9



**Kean University**  
1000 Morris Avenue  
Union, New Jersey 07083

## AutoCAD® Achievement Examination

Continuing Professional Education  
Advanced Computer Technology Center ACTC  
Nathan Weiss College of Graduate Studies

### Question 29

You need to duplicate an object in a rectangular pattern. This requires you to enter the number of rows and columns. You also must enter the distance between rows and columns. What command allows you to perform this operation?

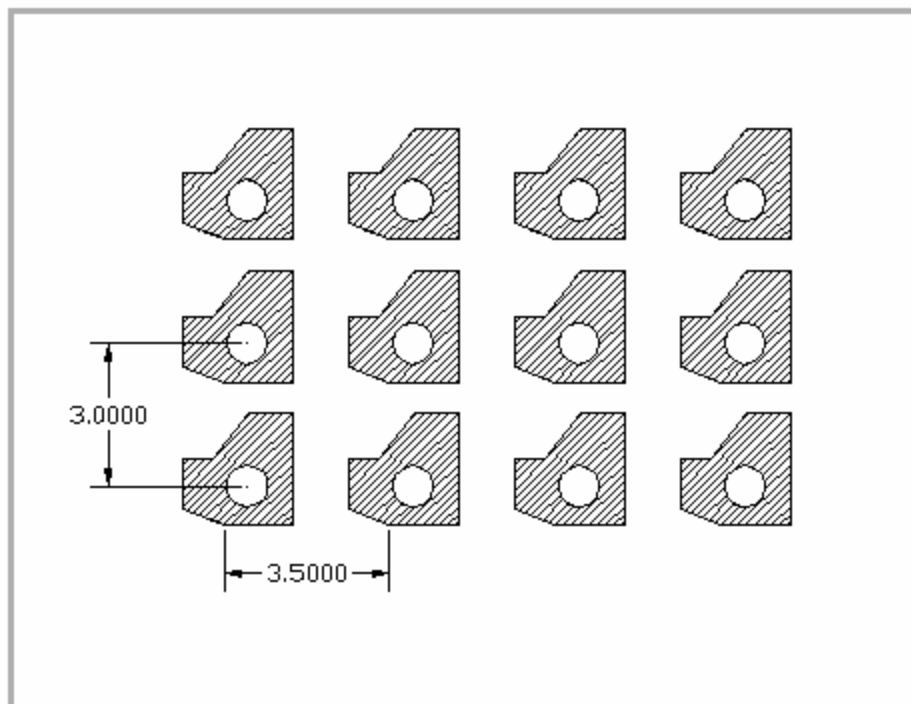

- A  Array
- B  Copy
- C  Mirror
- D  Move





**Kean University**  
1000 Morris Avenue  
Union, New Jersey 07083

## AutoCAD® Achievement Examination

Continuing Professional Education  
Advanced Computer Technology Center ACTC  
Nathan Weiss College of Graduate Studies

### Question 30

You enter the TRIM command. When prompted to select cutting edges at the “Select objects:” prompt, you press the ENTER key. What will be the result?

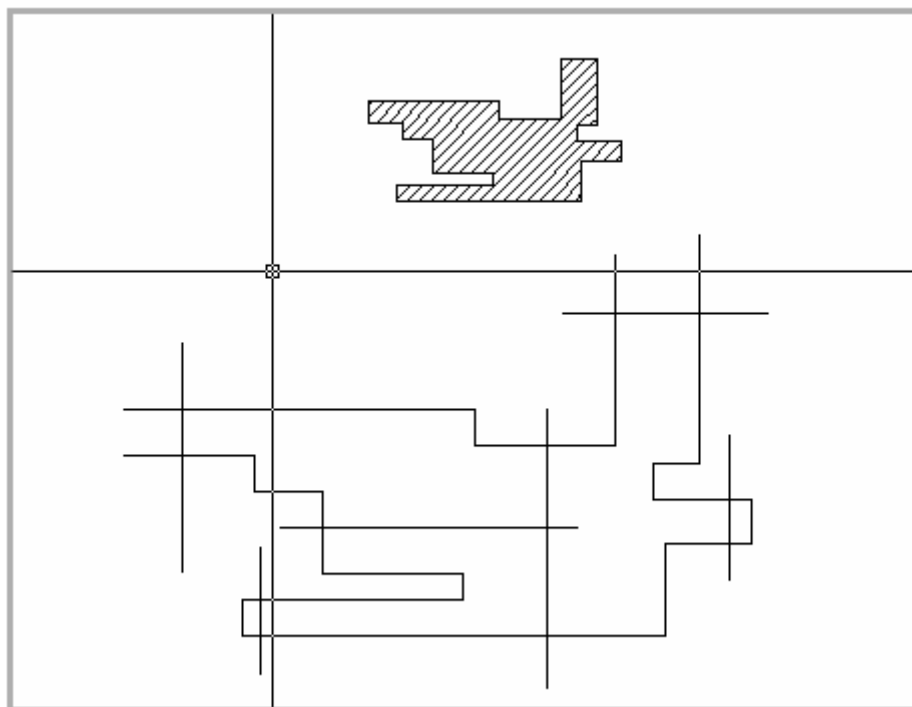

- A  AutoCAD exits the TRIM command
- B  The statement “Invalid” will appear
- C  The “Select objects:” prompt is displayed again
- D  All objects on the screen are selected as cutting edges



**Kean University**  
1000 Morris Avenue  
Union, New Jersey 07083

## AutoCAD® Achievement Examination

Continuing Professional Education  
Advanced Computer Technology Center ACTC  
Nathan Weiss College of Graduate Studies

### Question 31

When the object, located at point “A”, needs to be moved to location “B”, in the drawing below (the arrow is showing the direction of the move), what information should be specified at the command prompt?

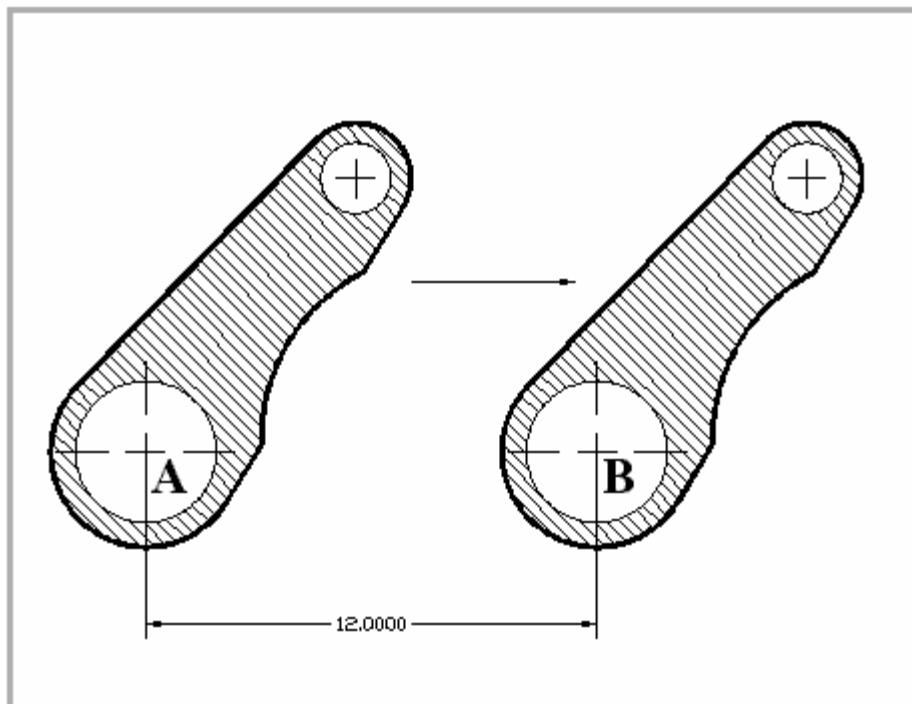

- A  @ 12,0
- B  12,0,12
- C  @ 0,12
- D  12 > 0



**Kean University**  
1000 Morris Avenue  
Union, New Jersey 07083

## AutoCAD® Achievement Examination

Continuing Professional Education  
Advanced Computer Technology Center ACTC  
Nathan Weiss College of Graduate Studies

### Question 32

When 2.9928" diameter circle needs to be multiplied in the manner shown bellow, which procedure is most likely to be used, and what angle exists between these circles?

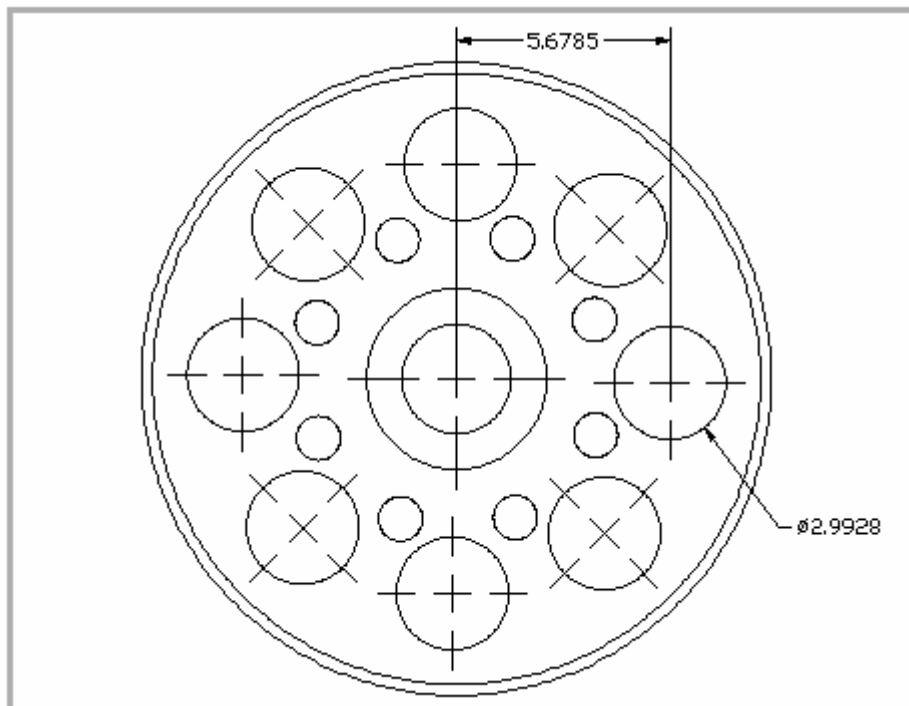

- A  Polar array; 45° angle
- B  Copy; 36° angle
- C  Polar array; 54° angle
- D  Move; 54°



**Kean University**  
1000 Morris Avenue  
Union, New Jersey 07083

## AutoCAD® Achievement Examination

Continuing Professional Education  
Advanced Computer Technology Center ACTC  
Nathan Weiss College of Graduate Studies

### Question 33

In the drawing below, you have to arrange the squares in the fashion shown. Which would be the most practical procedure most likely to be utilized to achieve the arrangement?

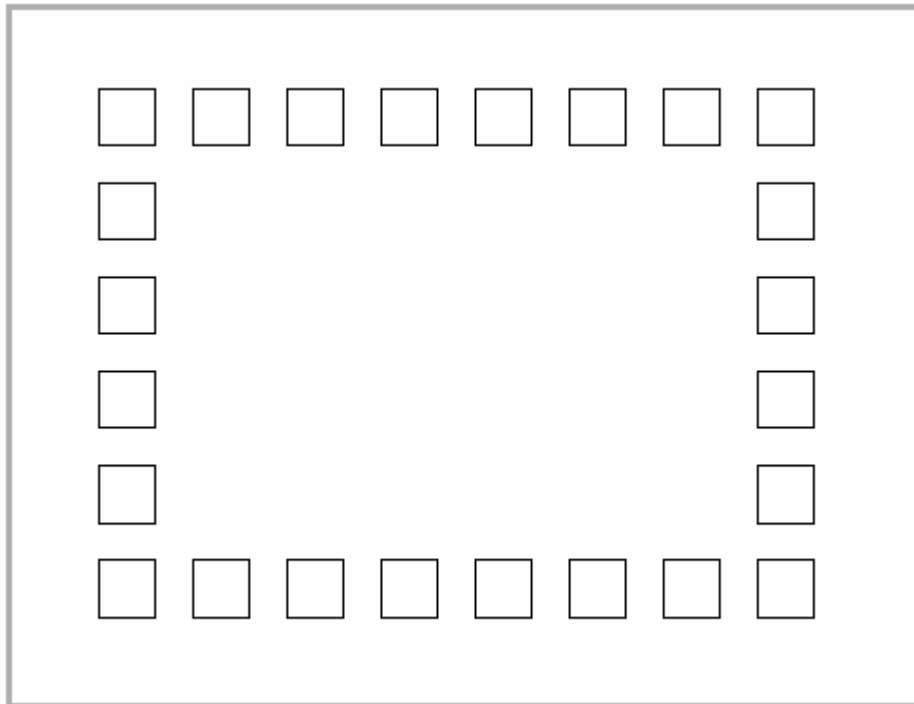

- A  Make two rectangular arrays then copy
- B  Draw four independent rectangular arrays
- C  Create one rectangular array then erase the middle part
- D  Copy one square 24 times



**Kean University**  
1000 Morris Avenue  
Union, New Jersey 07083

## AutoCAD® Achievement Examination

Continuing Professional Education  
Advanced Computer Technology Center ACTC  
Nathan Weiss College of Graduate Studies

### Question 34

What procedure sequence is best used to relocate the gear tooth, shown in figure below, from a position "A" to a position "B"?

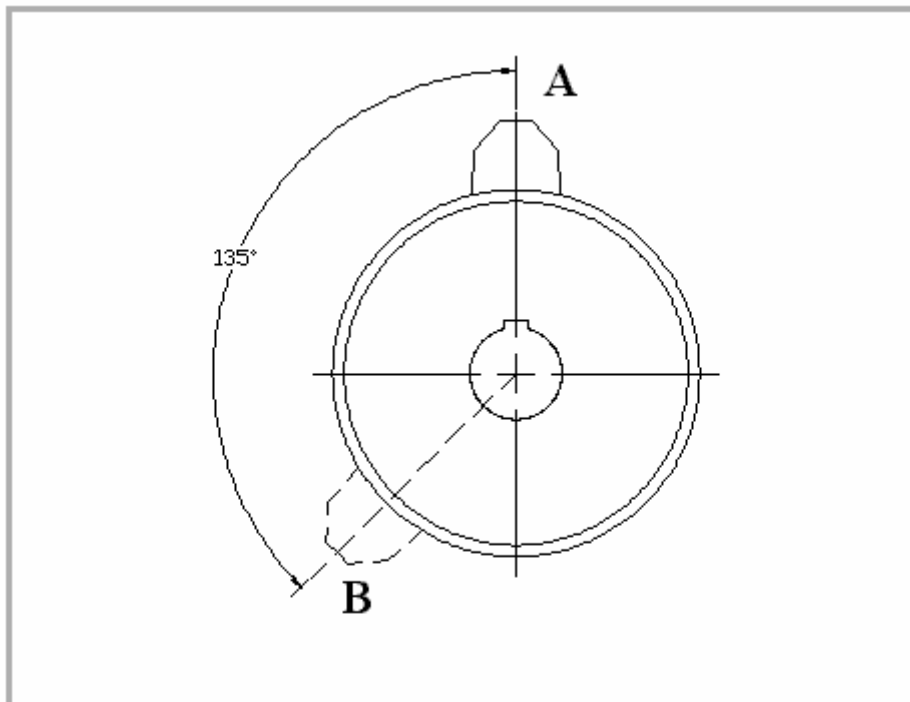

- A  Copy
- B  Rotate
- C  Move
- D  Array



**Kean University**  
1000 Morris Avenue  
Union, New Jersey 07083

## AutoCAD® Achievement Examination

Continuing Professional Education  
Advanced Computer Technology Center ACTC  
Nathan Weiss College of Graduate Studies

### Question 35

In the drawing shown below, which procedure was just performed by the operator?

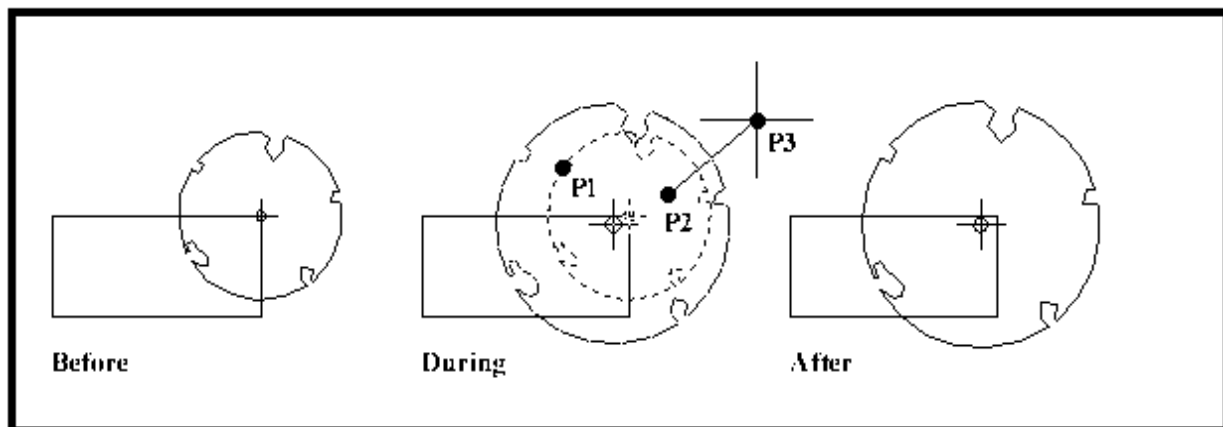

- A  Copy
- B  Move
- C  Scale
- D  Rotate



**Kean University**  
1000 Morris Avenue  
Union, New Jersey 07083

## AutoCAD® Achievement Examination

Continuing Professional Education  
Advanced Computer Technology Center ACTC  
Nathan Weiss College of Graduate Studies

### Question 36

Which is the most common and shortest procedure to create an angular line depicted as “ITEM 1” in the drawing below?

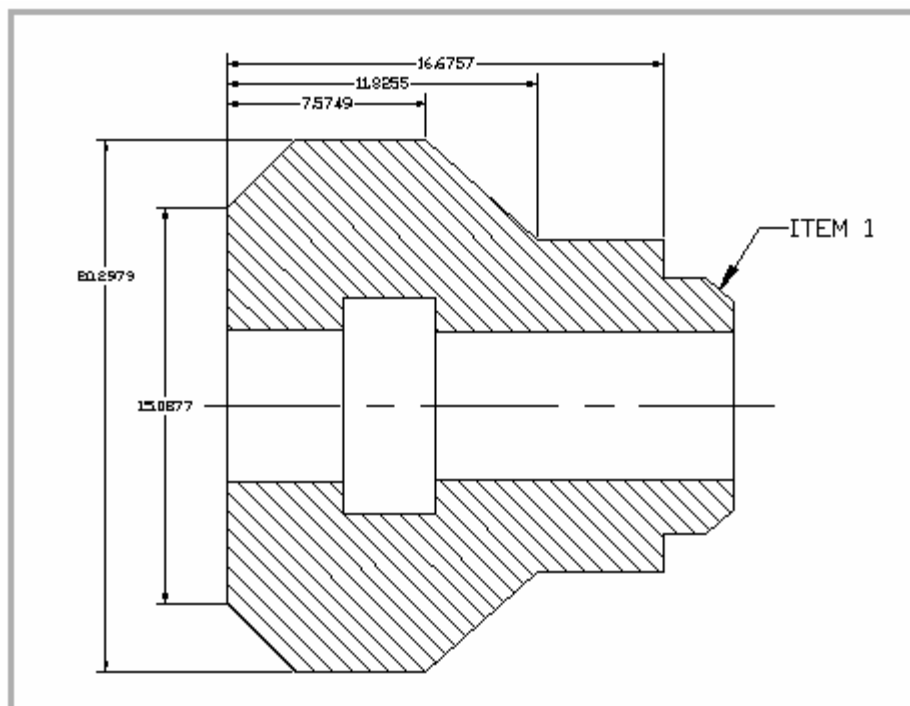

- A  Rotate
- B  Chamfer
- C  Offset
- D  Fillet



**Kean University**  
1000 Morris Avenue  
Union, New Jersey 07083

## AutoCAD® Achievement Examination

Continuing Professional Education  
Advanced Computer Technology Center ACTC  
Nathan Weiss College of Graduate Studies

### Question 37

In the Architectural drawing below, to produce an open garage door area from Point A to Point B, which command is most practical to use if the distance between points is known?

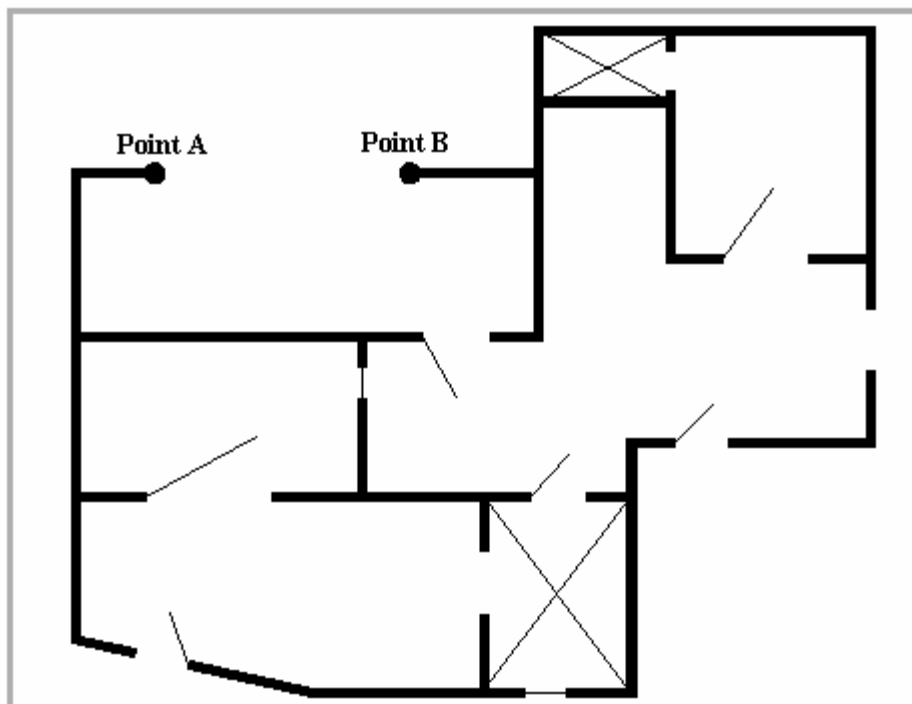

- A  Break
- B  Erase
- C  Undo
- D  Cut





**Kean University**  
1000 Morris Avenue  
Union, New Jersey 07083

## AutoCAD® Achievement Examination

Continuing Professional Education  
Advanced Computer Technology Center ACTC  
Nathan Weiss College of Graduate Studies

### Question 38

To produce a duplicate side of the building along the Line A as shown on the drawing below, from Side 1 to Side 2, which command was most likely to have been performed?

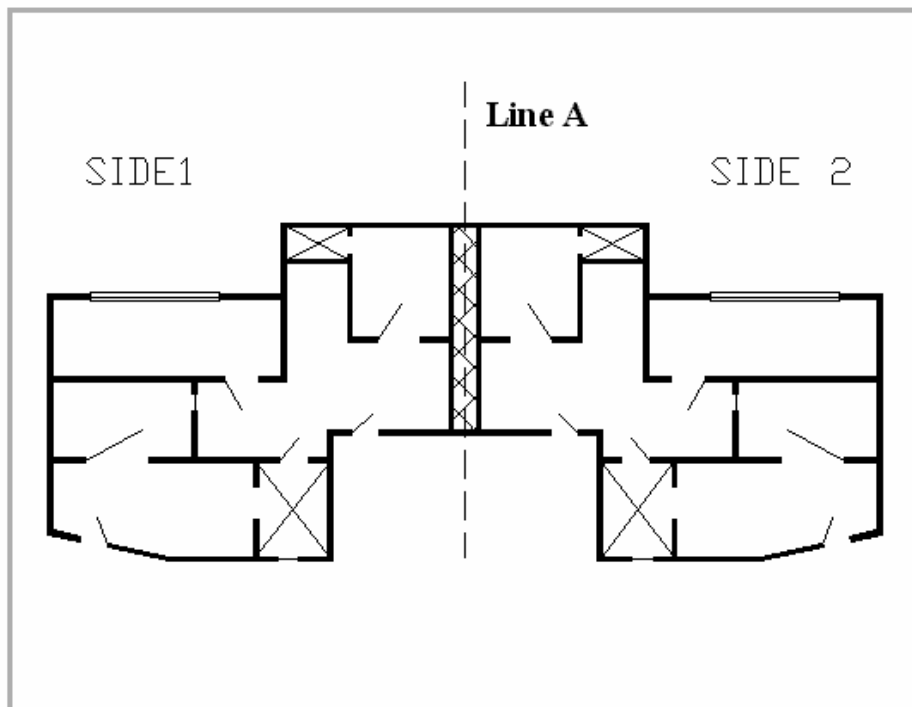

- A  Copy
- B  Rotate
- C  Mirror
- D  Stretch



**Kean University**  
1000 Morris Avenue  
Union, New Jersey 07083

## AutoCAD® Achievement Examination

Continuing Professional Education  
Advanced Computer Technology Center ACTC  
Nathan Weiss College of Graduate Studies

---

### Question 39

What is the most practical way to produce multiple slots in the base plate drawing shown in the figure below?

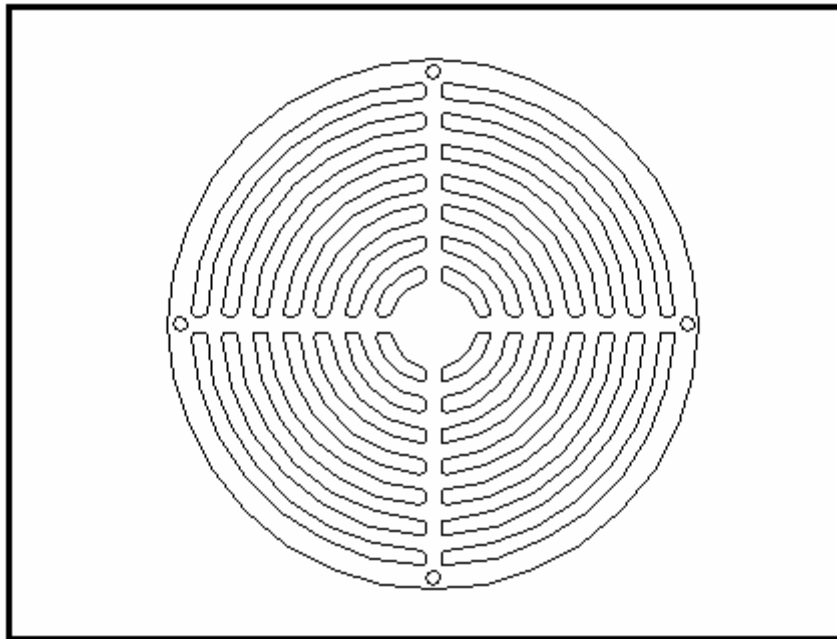

- A  Use Copy command 28 times
  - B  Create a set of 7 slots then use circular array
  - C  Create a set of 7 slots then copy 4 times
  - D  Produce one slot then move it 28 times
-



**Kean University**  
1000 Morris Avenue  
Union, New Jersey 07083

## AutoCAD® Achievement Examination

Continuing Professional Education  
Advanced Computer Technology Center ACTC  
Nathan Weiss College of Graduate Studies

---

### Question 40

What command can best be used to create “Rect. 2” or “Rect. 3” from the original rectangle #1?

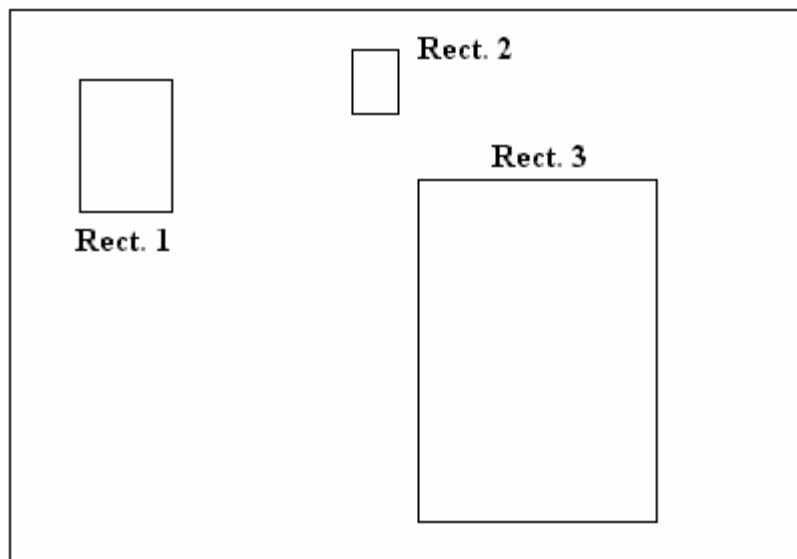

- A  Change
  - B  Extend
  - C  Move
  - D  Scale
-



**Kean University**  
1000 Morris Avenue  
Union, New Jersey 07083

## AutoCAD® Achievement Examination

Continuing Professional Education  
Advanced Computer Technology Center ACTC  
Nathan Weiss College of Graduate Studies

### Question 41

To quickly produce all 0.1864 Diameter circles shown in the figure, which command is best used?

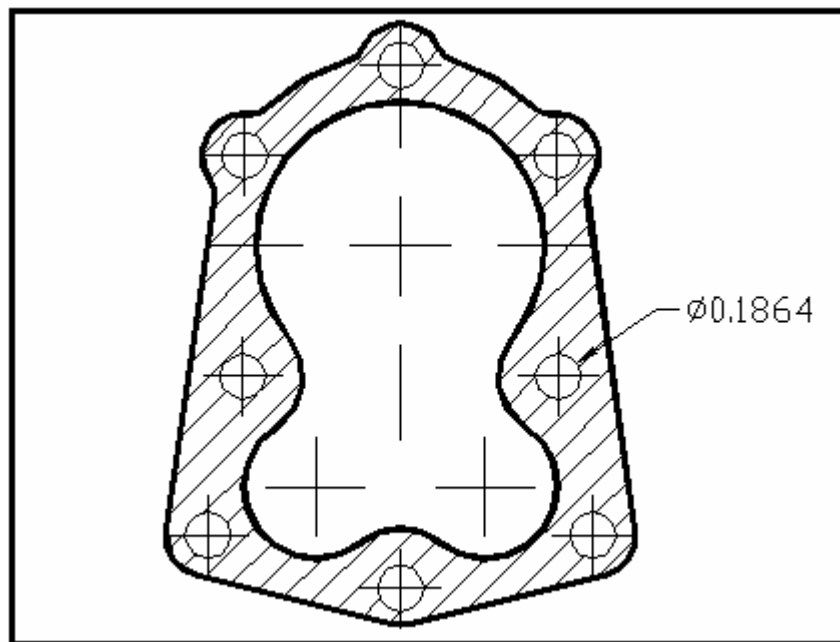

- A  Point
- B  Rectangle
- C  Copy - Multiple
- D  Redo

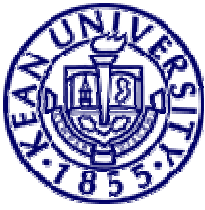

**Kean University**  
1000 Morris Avenue  
Union, New Jersey 07083

## AutoCAD® Achievement Examination

Continuing Professional Education  
Advanced Computer Technology Center ACTC  
Nathan Weiss College of Graduate Studies

### Question 42

To orient the bracket from a straight position to the angle shown below around the indicated Pivot Point, what procedure is most likely to be used?

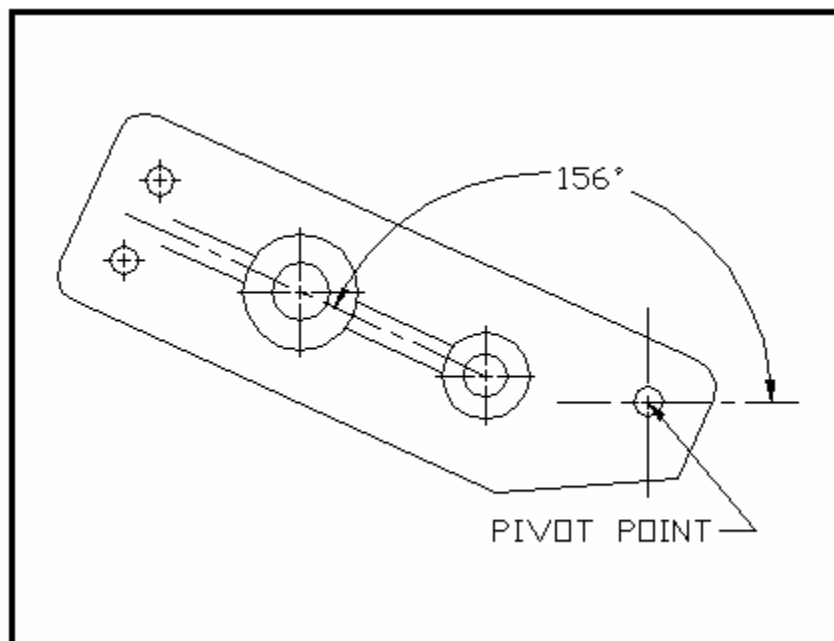

- A  Re-orient 156°
- B  Rotate 156°
- C  Rotate 24°
- D  Re-orient 24°



**Kean University**  
1000 Morris Avenue  
Union, New Jersey 07083

## AutoCAD® Achievement Examination

Continuing Professional Education  
Advanced Computer Technology Center ACTC  
Nathan Weiss College of Graduate Studies

### Question 43

In a standard (default) AutoCAD drawing session, there are usually four traditional toolbars shown – two on the top of the screen and two on the left side. Based on the picture shown below, which one of the typical toolbar components is missing from the toolbar selection dialog box?

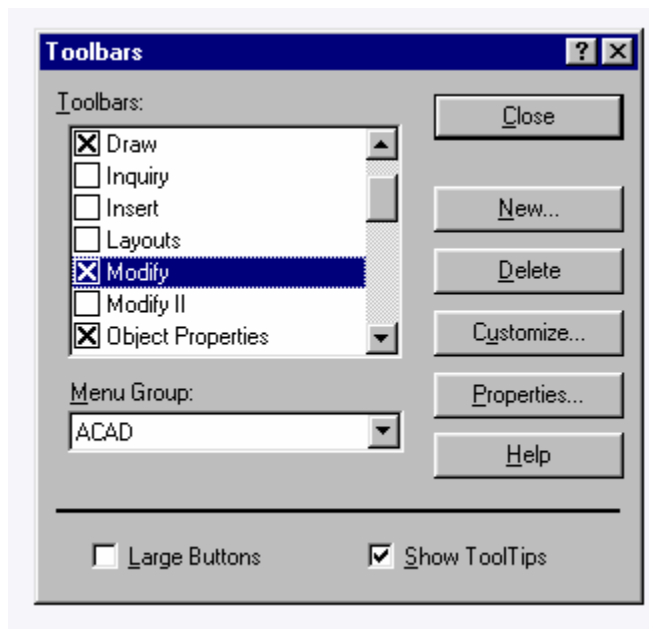

- A  "Shading toolbar
- B  "Dimension toolbar
- C  "Copy and Erase toolbar
- D  "Standard" toolbar



**Kean University**  
1000 Morris Avenue  
Union, New Jersey 07083

## AutoCAD® Achievement Examination

Continuing Professional Education  
Advanced Computer Technology Center ACTC  
Nathan Weiss College of Graduate Studies

### Question 44

In the drawing shown below, which procedure was just performed by the operator?

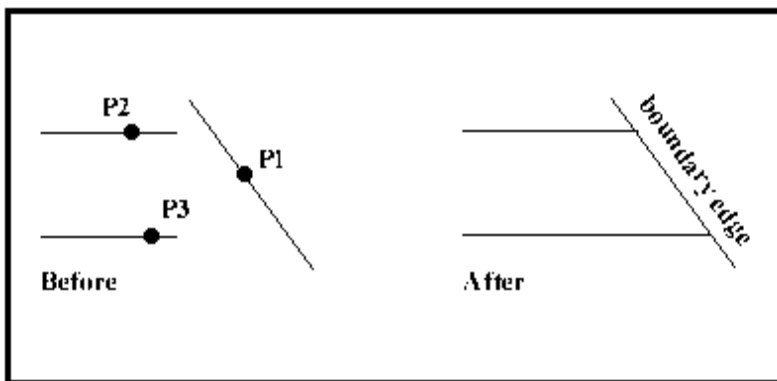

- A  Stretch
- B  Extend
- C  Rectangle
- D  Line



**Kean University**  
1000 Morris Avenue  
Union, New Jersey 07083

## AutoCAD® Achievement Examination

Continuing Professional Education  
Advanced Computer Technology Center ACTC  
Nathan Weiss College of Graduate Studies

### Question 45

Please match the icon numbers shown in the sketch to the exact AutoCAD command sequence available in the multiple-choice area below:

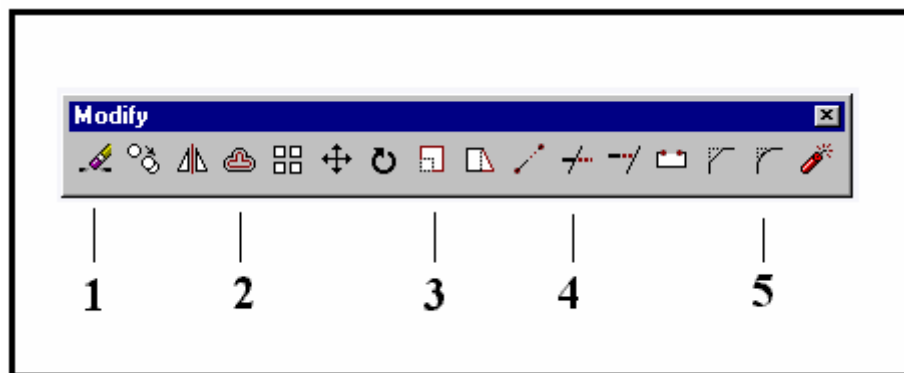

- A  Trim, Fillet, Line, Extend, Chamfer
- B  Erase, Offset, Scale, Trim, Fillet
- C  Extend, Trim, Scale, Offset, Erase
- D  Erase, Offset, Scale, Fillet, Trim





**Kean University**  
1000 Morris Avenue  
Union, New Jersey 07083

## AutoCAD® Achievement Examination

Continuing Professional Education  
Advanced Computer Technology Center ACTC  
Nathan Weiss College of Graduate Studies

### Question 46

In the drawing below all horizontal dimensions are being dimensioned from a single datum point on the left of the part. Why is this type dimensioning method preferred in mechanical drafting, as opposed to the “continuous” (chain) dimensioning technique?

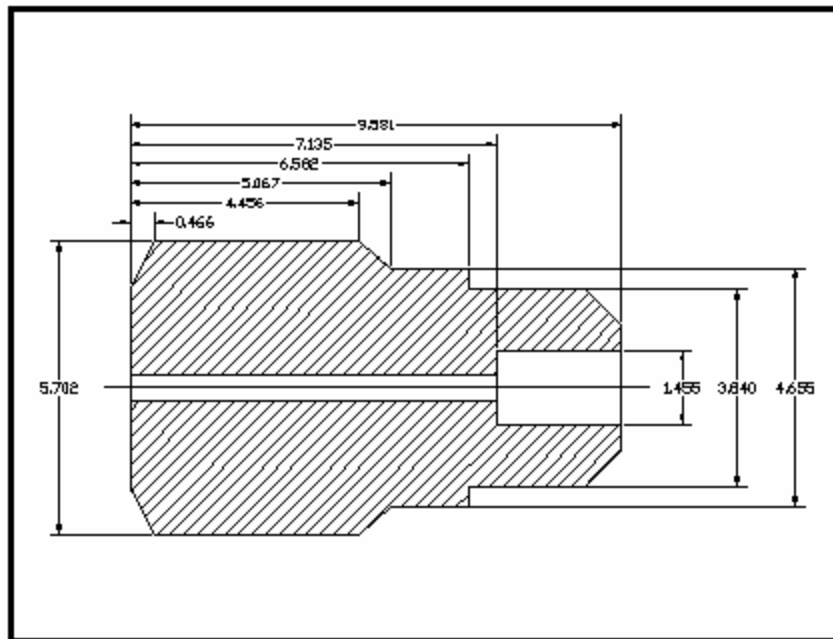

- A  It produces a more uniform look
- B  Dimensions will be better arranged
- C  Dimensions will be easier to double check
- D  This style prevents the tolerance build-up



**Kean University**  
1000 Morris Avenue  
Union, New Jersey 07083

## AutoCAD® Achievement Examination

Continuing Professional Education  
Advanced Computer Technology Center ACTC  
Nathan Weiss College of Graduate Studies

### Question 47

To create multiple duplicates of 1.20 diameter hole located at position 1 to the remaining positions 2,3,and 4, what would be the most practical solution?

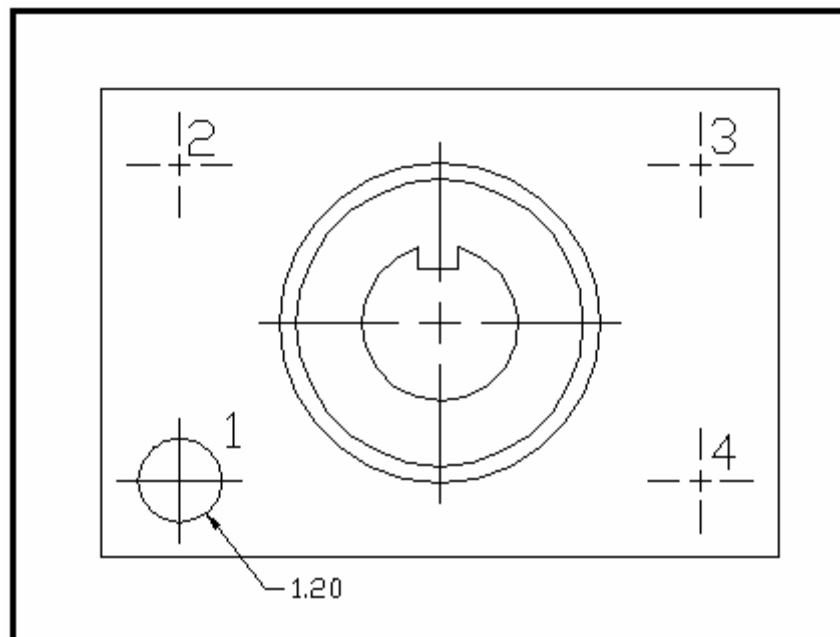

- A  Use Copy command 4 times
- B  Use Move command 4 times
- C  Rectangular array using 2 columns and 2 rows
- D  Polar array



**Kean University**  
1000 Morris Avenue  
Union, New Jersey 07083

## AutoCAD® Achievement Examination

Continuing Professional Education  
Advanced Computer Technology Center ACTC  
Nathan Weiss College of Graduate Studies

### Question 48

In the drawing shown below, which procedure was just performed by the operator?

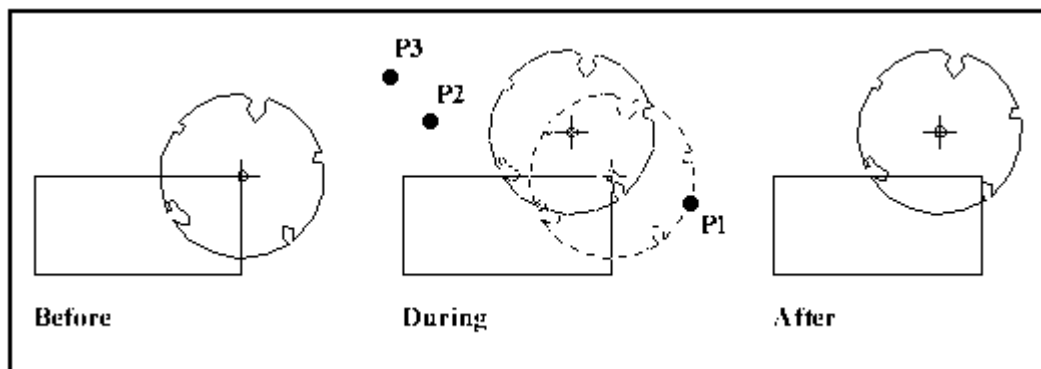

- A  Copy
- B  Move
- C  Array
- D  Mirror



**Kean University**  
1000 Morris Avenue  
Union, New Jersey 07083

## AutoCAD® Achievement Examination

Continuing Professional Education  
Advanced Computer Technology Center ACTC  
Nathan Weiss College of Graduate Studies

### Question 49

In the example drawing below, the dimension marked “DIM X” represents what dimensioning method?

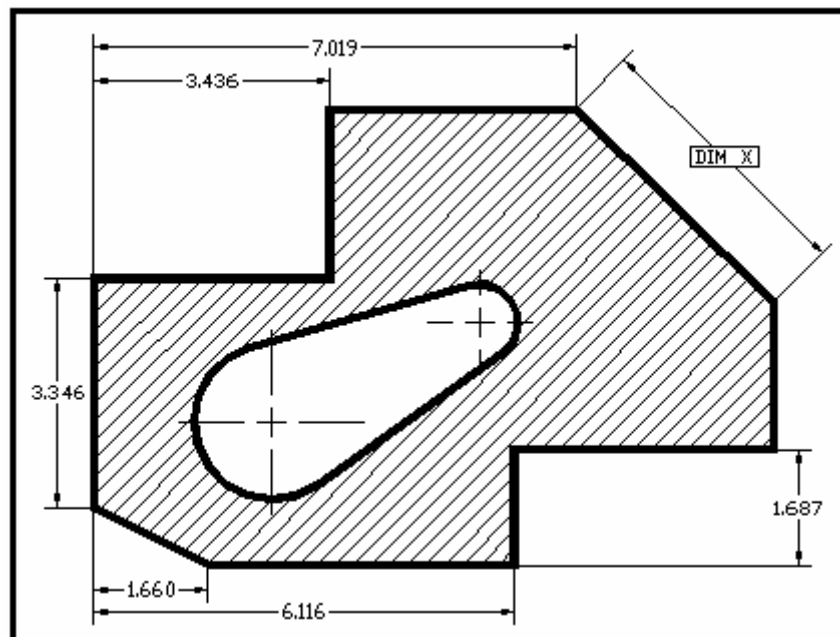

- A  Linear
- B  Aligned
- C  Angular
- D  Baseline



**Kean University**  
1000 Morris Avenue  
Union, New Jersey 07083

## AutoCAD® Achievement Examination

Continuing Professional Education  
Advanced Computer Technology Center ACTC  
Nathan Weiss College of Graduate Studies

### Question 50

Sometimes, within the AutoCAD's array command, an angle between items needs to be specified. In the Mechanical Gear shown below what is the angle between the gear teeth?

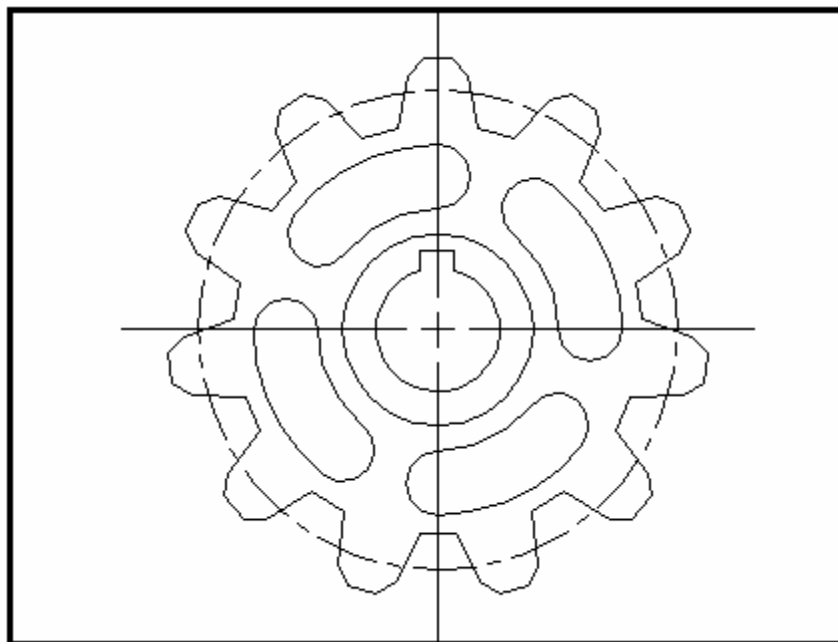

- A  45 °
- B  32.72 °
- C  29.23 °
- D  36 °



**Kean University**  
1000 Morris Avenue  
Union, New Jersey 07083

## AutoCAD® Achievement Examination

Continuing Professional Education  
Advanced Computer Technology Center ACTC  
Nathan Weiss College of Graduate Studies

### Question 51

What minimum list of Layers should be used in this drawing?  
Select from the choices below:

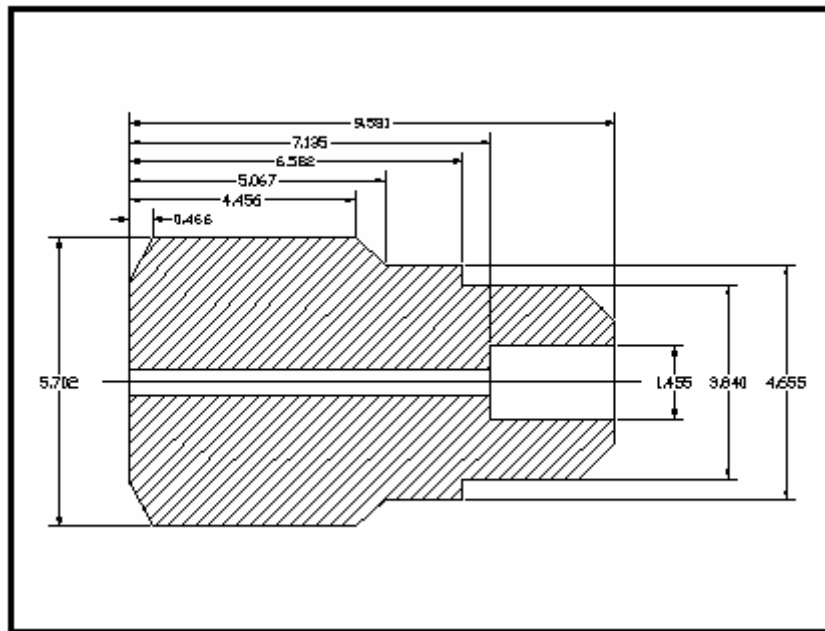

- A  Circles, rectangles, crosshatch
- B  Dimensions, boundary, cross-hatch
- C  Lines, circles
- D  Lines, circles, crosshatch, text



**Kean University**  
1000 Morris Avenue  
Union, New Jersey 07083

## AutoCAD® Achievement Examination

Continuing Professional Education  
Advanced Computer Technology Center ACTC  
Nathan Weiss College of Graduate Studies

### Question 52

What is a general purpose for creating additional Text Styles in technical drawings?

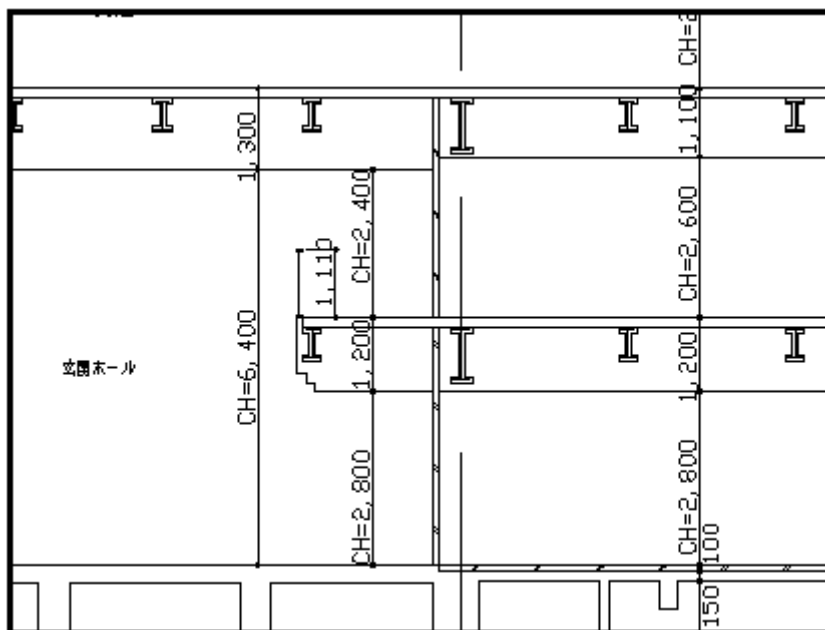

- A  Company's standards requirements
- B  A better, more uniform look
- C  Better visibility
- D  Fitting more text in the drawing Title Block



**Kean University**  
1000 Morris Avenue  
Union, New Jersey 07083

## AutoCAD® Achievement Examination

Continuing Professional Education  
Advanced Computer Technology Center ACTC  
Nathan Weiss College of Graduate Studies

### Question 53

What is the official technical term for the dashed line type shown in the drawing below?

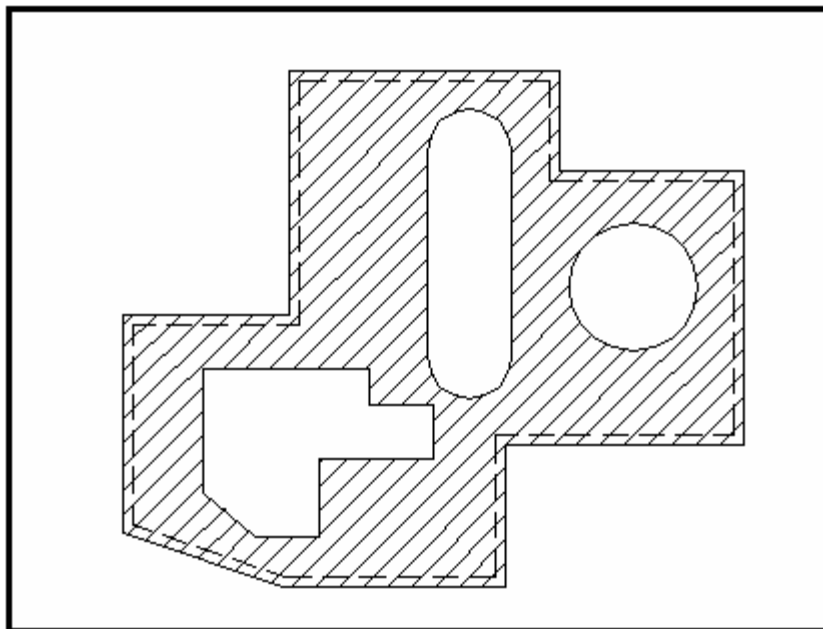

- A  Center
- B  Phantom
- C  Visible
- D  Hidden





**Kean University**  
1000 Morris Avenue  
Union, New Jersey 07083

## AutoCAD® Achievement Examination

Continuing Professional Education  
Advanced Computer Technology Center ACTC  
Nathan Weiss College of Graduate Studies

### Question 54

What is the official technical term for the line type located inside the circle and in the slot-type cutout shown in the drawing below?

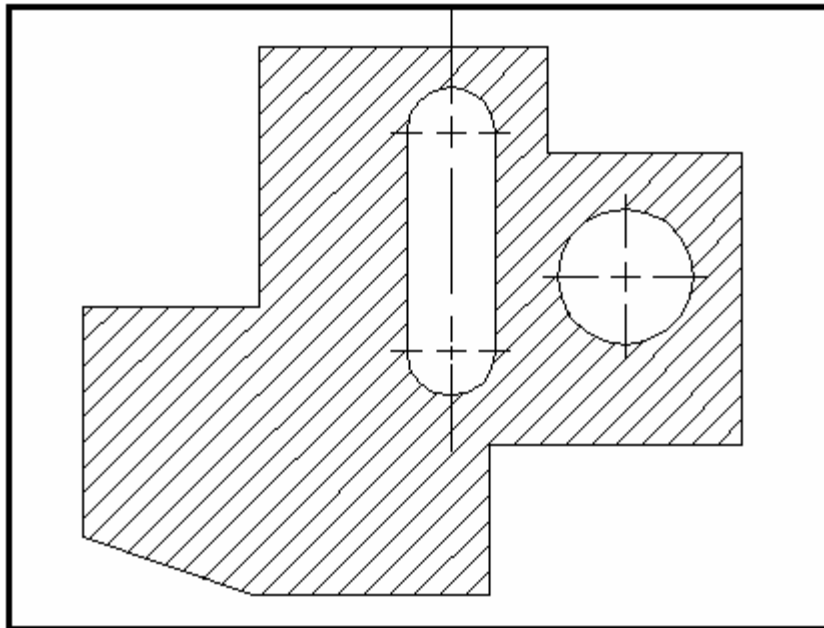

- A  Extension
- B  Center
- C  Phantom
- D  Hidden



**Kean University**  
1000 Morris Avenue  
Union, New Jersey 07083

## AutoCAD® Achievement Examination

Continuing Professional Education  
Advanced Computer Technology Center ACTC  
Nathan Weiss College of Graduate Studies

### Question 55

Which AutoCAD command has the menu shown? Please select from the choices below:

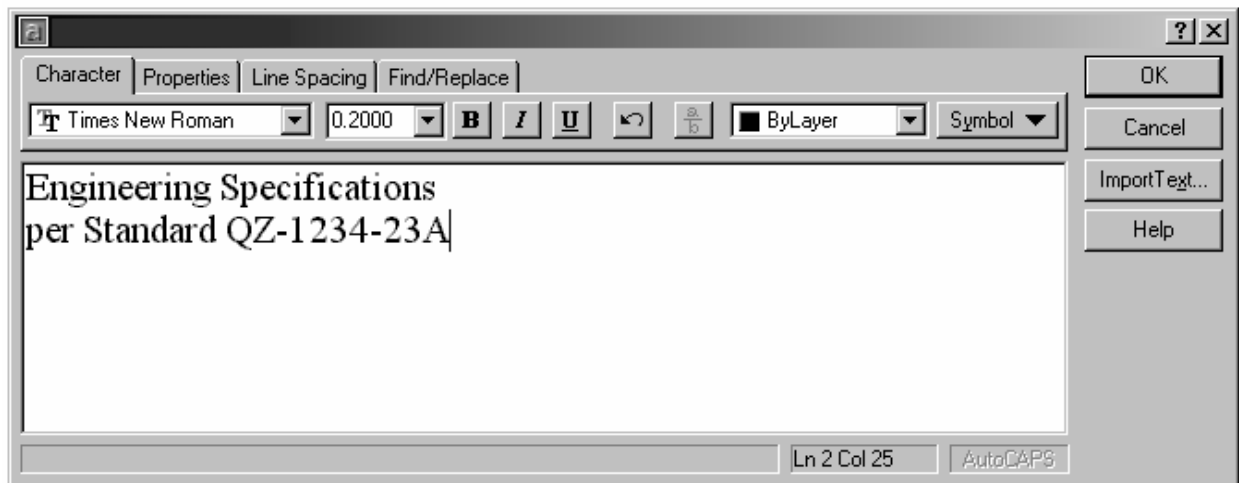

- A  Annotation
- B  Make notes
- C  Mtext
- D  Dtext



**Kean University**  
1000 Morris Avenue  
Union, New Jersey 07083

## AutoCAD® Achievement Examination

Continuing Professional Education  
Advanced Computer Technology Center ACTC  
Nathan Weiss College of Graduate Studies

### Question 56

In the drawing shown below, all horizontal dimensions are calculated from the same Datum located at the left side of the part. When using QDIM command, which letter selection would you choose at the command prompt?

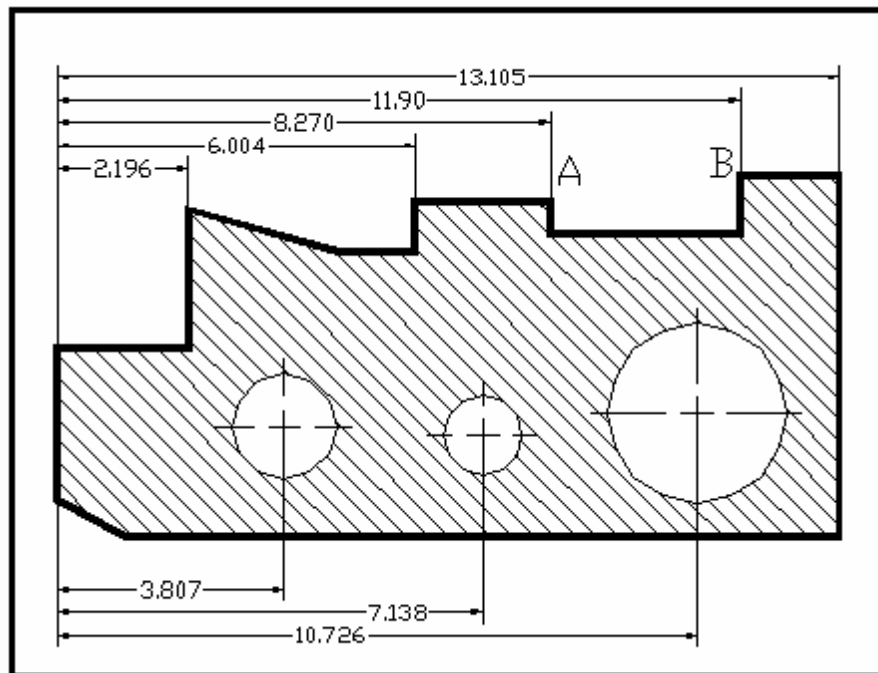

- A  Letter "O" for Ordinal
- B  Letter "B" for Baseline
- C  Letter "S" for Staggered
- D  None of the above letters



**Kean University**  
1000 Morris Avenue  
Union, New Jersey 07083

## AutoCAD<sup>®</sup> Achievement Examination

Continuing Professional Education  
Advanced Computer Technology Center ACTC  
Nathan Weiss College of Graduate Studies

### Question 57

The two vertical dimensions, shown in the drawing below, represent diameter-type dimensioning. In AutoCAD terminology, however, this type of dimensioning has a different name. Please choose the appropriate name from the selection of choices below.

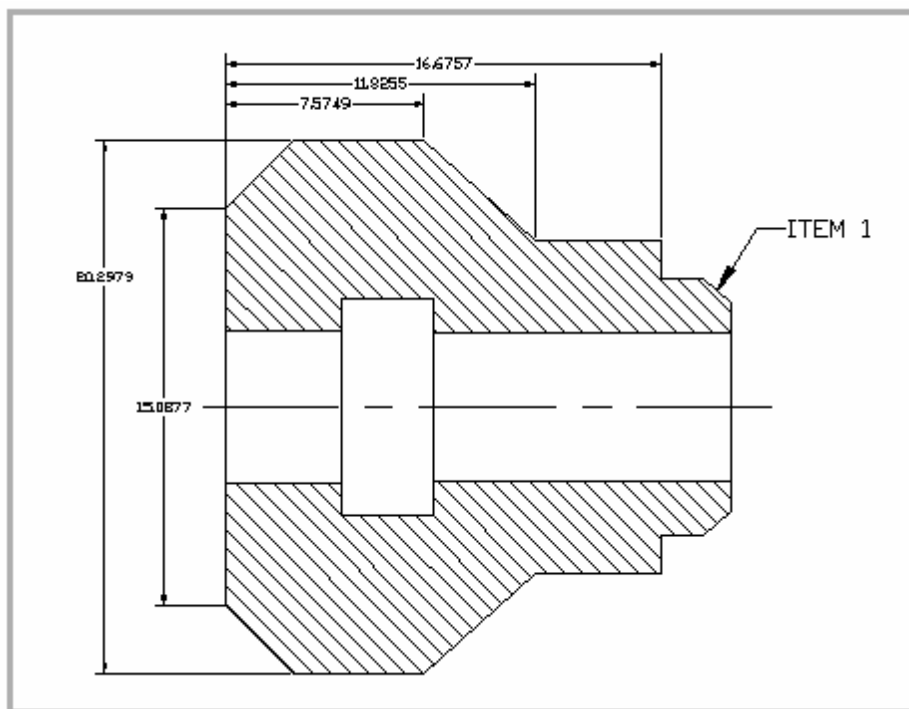

- A  "Sideways" dimensioning
- B  "Radial" dimensioning
- C  "Staggered" dimensioning
- D  "Continuous" dimensioning



**Kean University**  
1000 Morris Avenue  
Union, New Jersey 07083

## AutoCAD® Achievement Examination

Continuing Professional Education  
Advanced Computer Technology Center ACTC  
Nathan Weiss College of Graduate Studies

### Question 58

What AutoCAD command includes the menu shown below? Please select from the available choices:

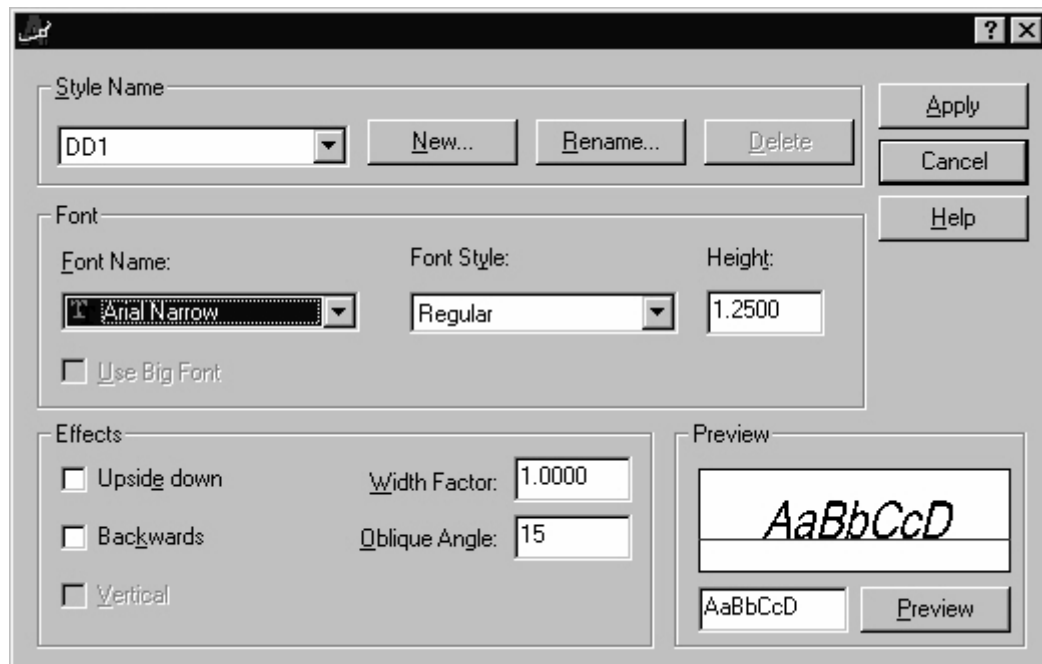

- A  Text Style
- B  Annotation
- C  Dim Style
- D  LISP Editor



**Kean University**  
1000 Morris Avenue  
Union, New Jersey 07083

## AutoCAD® Achievement Examination

Continuing Professional Education  
Advanced Computer Technology Center ACTC  
Nathan Weiss College of Graduate Studies

### Question 59

In the Layout mode of AutoCAD's Paper-Space module, the four rectangular windows shown below are usually referred to as what name?

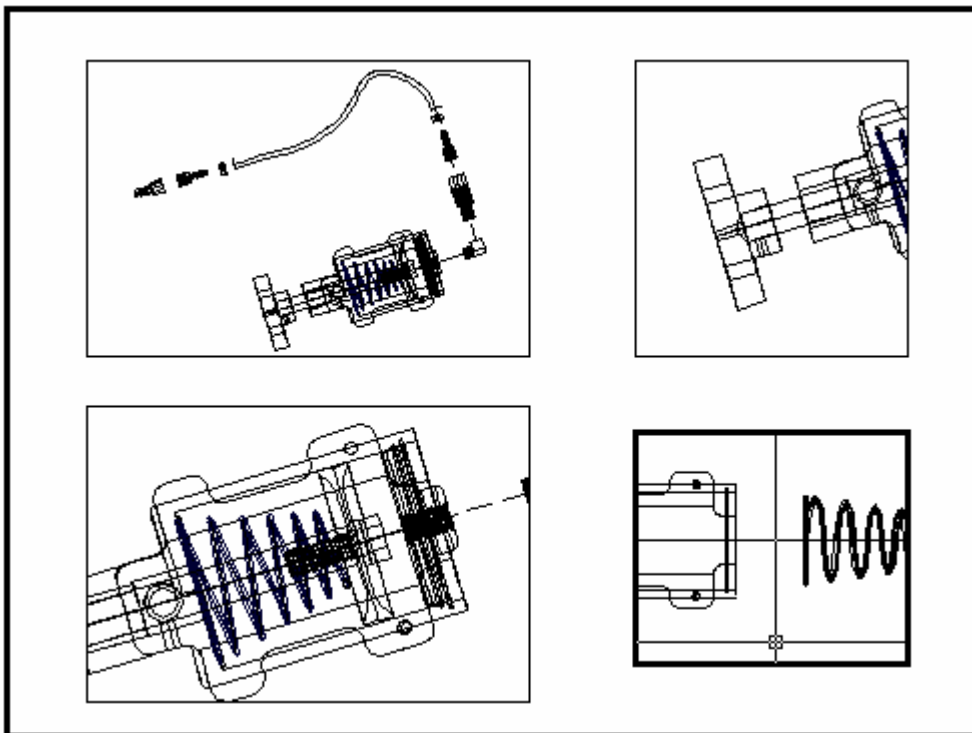

- A  Segments
- B  Sections
- C  View ports
- D  Quick view windows



**Kean University**  
1000 Morris Avenue  
Union, New Jersey 07083

## AutoCAD® Achievement Examination

Continuing Professional Education  
Advanced Computer Technology Center ACTC  
Nathan Weiss College of Graduate Studies

### Question 60

During the AutoCAD Layout procedure, when the drawing needs to be plotted at scale factor of 1:40, what does this scale factor represent?

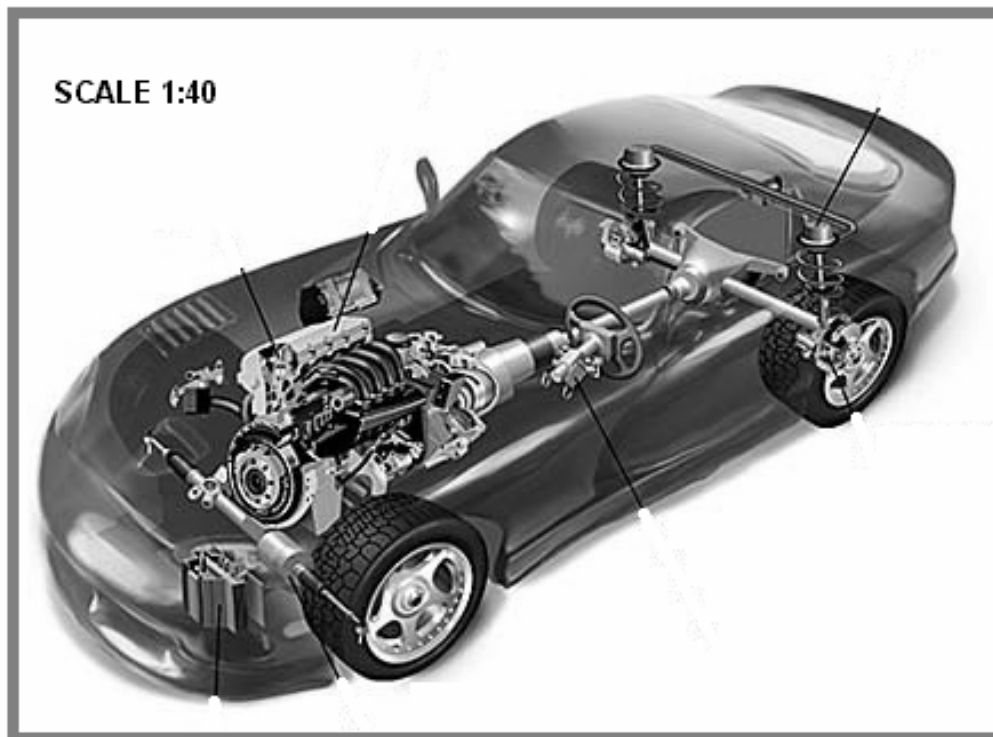

- A  Paper plot is 40 times larger than the actual object
- B  Actual object is equal to the paper plot
- C  Paper plot is 40 times smaller than the actual object
- D  None of the above choices



**Kean University**  
1000 Morris Avenue  
Union, New Jersey 07083

## AutoCAD® Achievement Examination

Continuing Professional Education  
Advanced Computer Technology Center ACTC  
Nathan Weiss College of Graduate Studies

### Question 61

What is the general purpose for using AutoCAD's Paper-Space layout procedure?

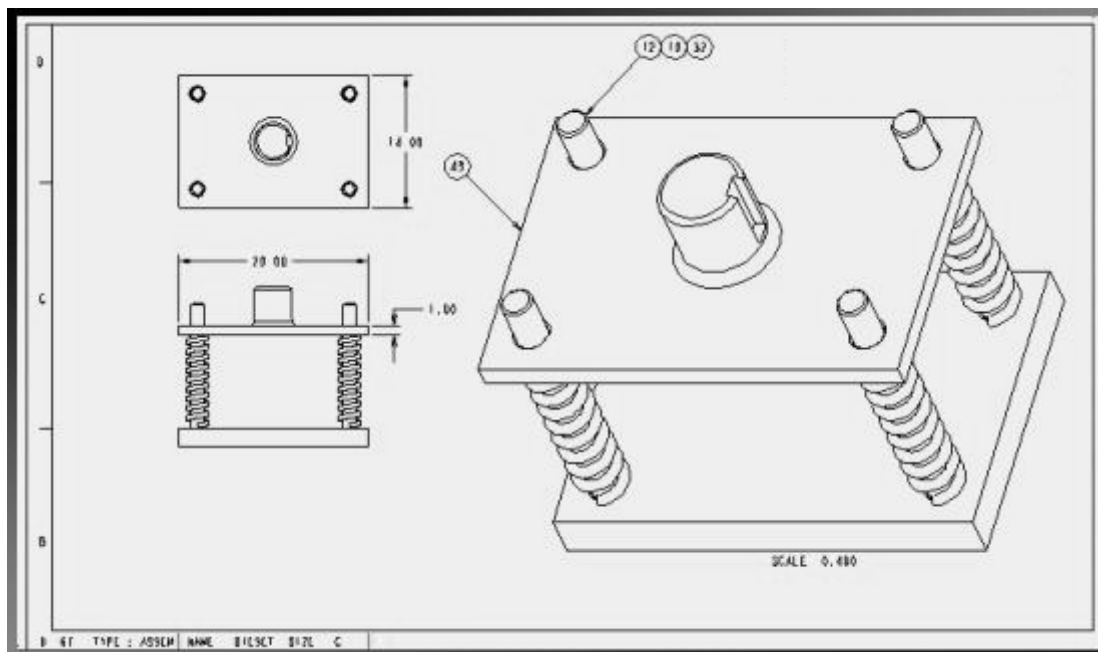

- A  Gives you the ability to plot multiple views of a drawing
- B  Helps to produce a more uniform look of objects on a drawing
- C  Lets operator save paper, when plotting.
- D  Permits user to fit more objects into the AutoCAD screen





**Kean University**  
1000 Morris Avenue  
Union, New Jersey 07083

## AutoCAD® Achievement Examination

Continuing Professional Education  
Advanced Computer Technology Center ACTC  
Nathan Weiss College of Graduate Studies

### Question 62

While using the LAYER command, sometimes it is necessary to turn certain layers off. In your opinion, what is the general purpose for such a procedure?

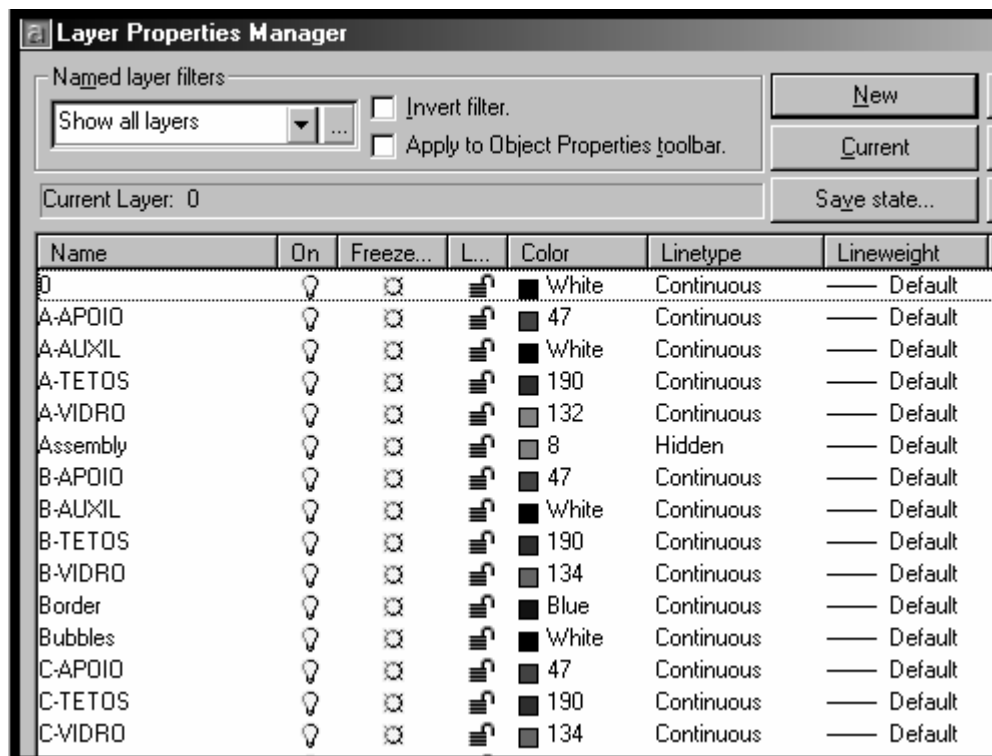

- A  Producing better definition of the remaining layers
- B  Lock of unnecessary objects
- C  Moving the layers to a new location
- D  None of the above



**Kean University**  
1000 Morris Avenue  
Union, New Jersey 07083

## AutoCAD® Achievement Examination

Continuing Professional Education  
Advanced Computer Technology Center ACTC  
Nathan Weiss College of Graduate Studies

### Question 63

From the selection below, what may be the most appropriate layer name, representing the angled lines in this drawing?

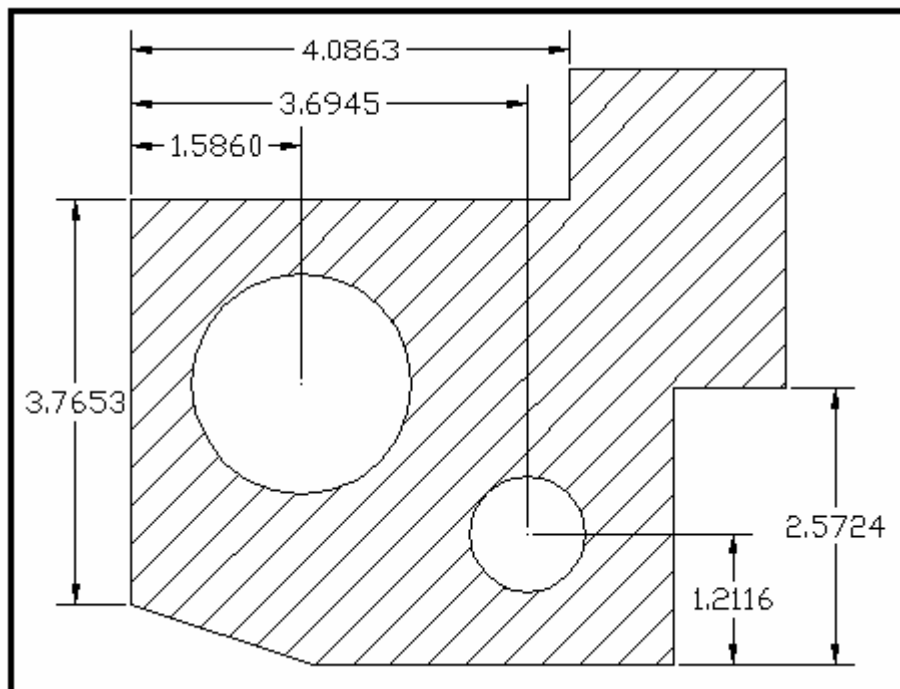

- A  Dimension
- B  Centerline
- C  Shading
- D  Crosshatch



**Kean University**  
1000 Morris Avenue  
Union, New Jersey 07083

# AutoCAD<sup>®</sup> Achievement Examination

Continuing Professional Education  
Advanced Computer Technology Center ACTC  
Nathan Weiss College of Graduate Studies

## Question 64

Which Linetype, from selection shown below, should you use to depict the location of arcs and circles?

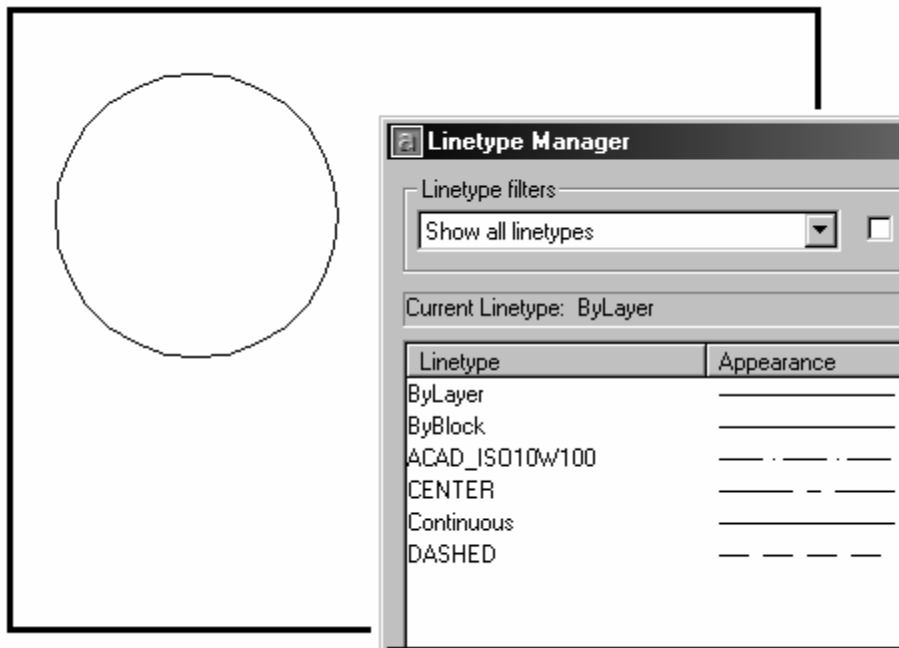

- A  Third from the bottom of the list
- B  On the very bottom of the list
- C  Third from the top of the list
- D  None of the above



**Kean University**  
1000 Morris Avenue  
Union, New Jersey 07083

## AutoCAD® Achievement Examination

Continuing Professional Education  
Advanced Computer Technology Center ACTC  
Nathan Weiss College of Graduate Studies

---

### Question 65

When the text component inside of the rectangle was selected for editing, both lines of text were simultaneously highlighted, allowing the entire note to be edited. Which AutoCAD command was used to create this note?

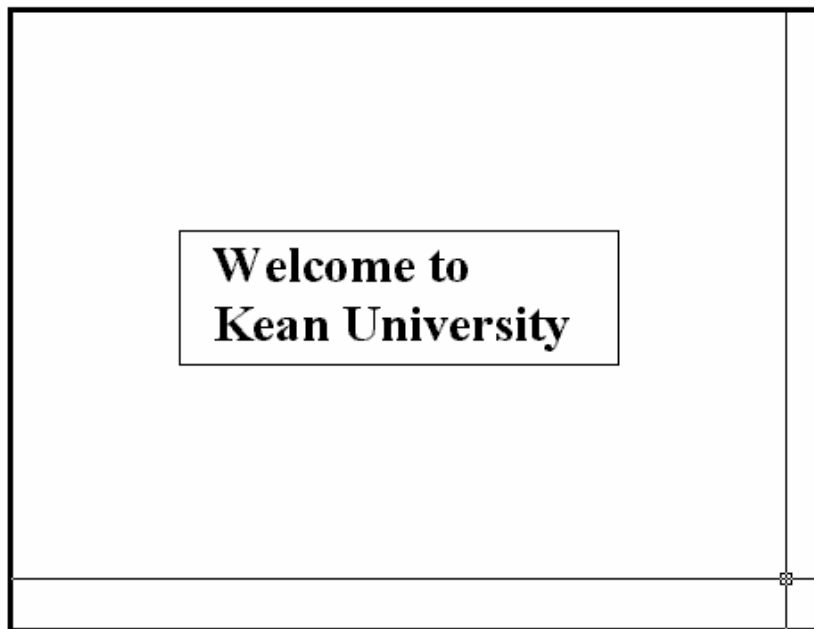

- A  Dtext
  - B  Classical text
  - C  Mtext
  - D  Make note
-



**Kean University**  
1000 Morris Avenue  
Union, New Jersey 07083

## AutoCAD® Achievement Examination

Continuing Professional Education  
Advanced Computer Technology Center ACTC  
Nathan Weiss College of Graduate Studies

### Question 66

What command does this menu belong to?

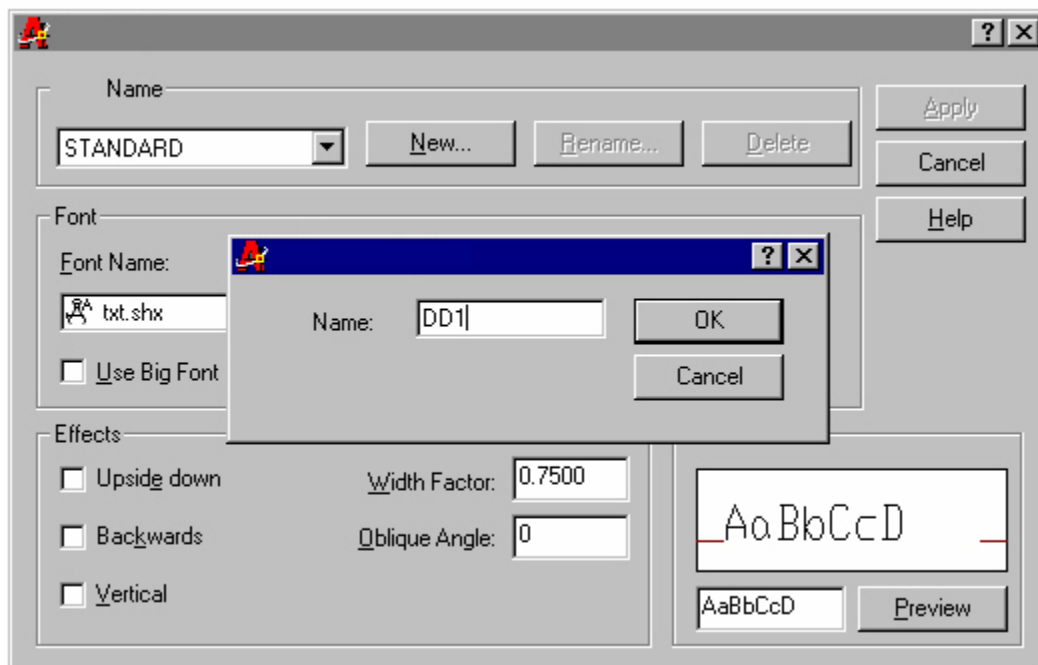

- A  Dtext
- B  Text
- C  Mtext
- D  Text style

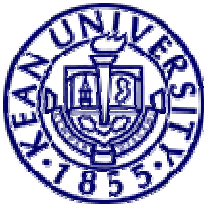

**Kean University**  
1000 Morris Avenue  
Union, New Jersey 07083

## AutoCAD® Achievement Examination

Continuing Professional Education  
Advanced Computer Technology Center ACTC  
Nathan Weiss College of Graduate Studies

### Question 67

It the selection of images below, which AutoCAD Layout Mode is represented by Figure A? Select from the choices below.

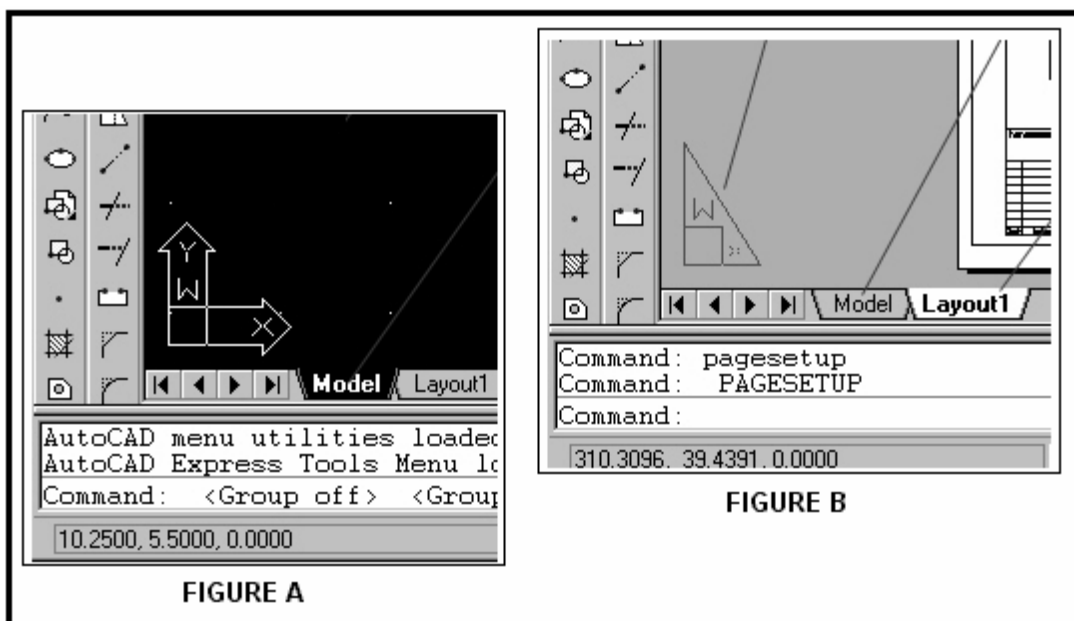

- A  Paper Space
- B  Regular Space
- C  Model Space
- D  None of the above



**Kean University**  
1000 Morris Avenue  
Union, New Jersey 07083

## AutoCAD® Achievement Examination

Continuing Professional Education  
Advanced Computer Technology Center ACTC  
Nathan Weiss College of Graduate Studies

### Question 68

What is the general purpose for creating and working with Blocks in AutoCAD?

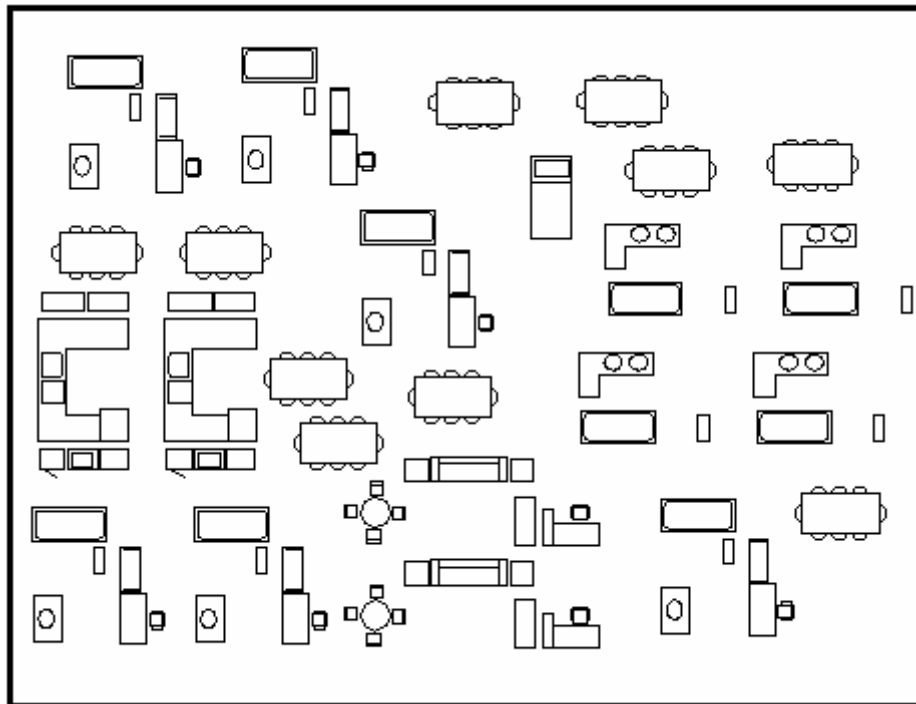

- A  To create custom component libraries
- B  To draw objects quicker
- C  To build architectural structures
- D  To erase groups of objects



**Kean University**  
1000 Morris Avenue  
Union, New Jersey 07083

## AutoCAD® Achievement Examination

Continuing Professional Education  
Advanced Computer Technology Center ACTC  
Nathan Weiss College of Graduate Studies

### Question 69

It the selection of images below, which AutoCAD Layout Mode is represented by Figure B? Select from the choices below.

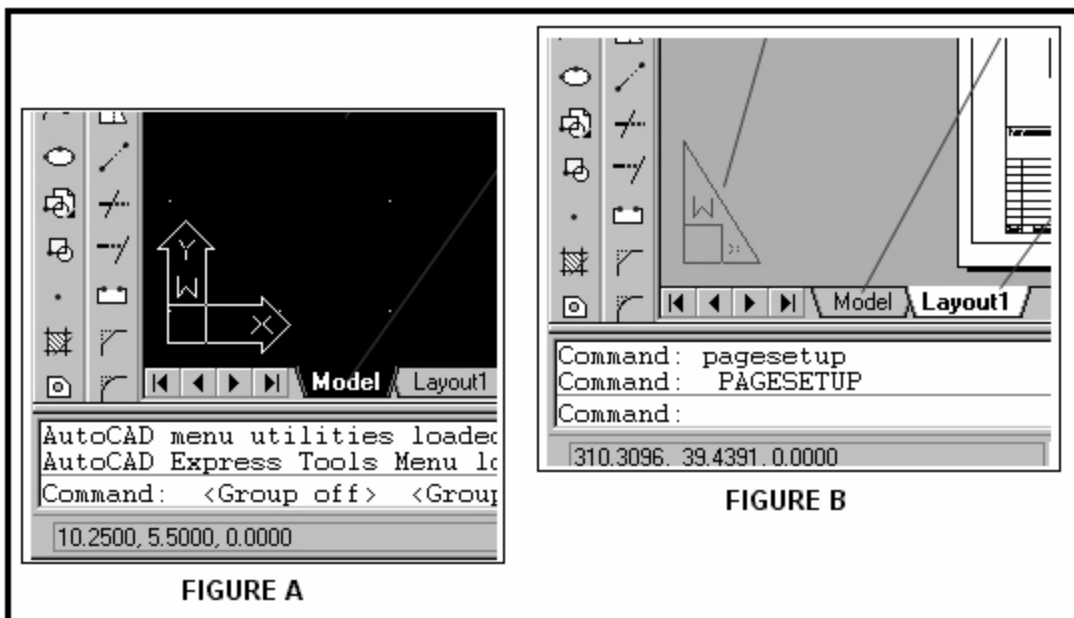

- A  Paper Space
- B  Regular Space
- C  Model Space
- D  None of the above





**Kean University**  
1000 Morris Avenue  
Union, New Jersey 07083

## AutoCAD® Achievement Examination

Continuing Professional Education  
Advanced Computer Technology Center ACTC  
Nathan Weiss College of Graduate Studies

### Question 70

When Using QDIM command to dimension six horizontal dimensions in the drawing below, which letter selection, indicating type of dimension, would you choose at the command prompt?

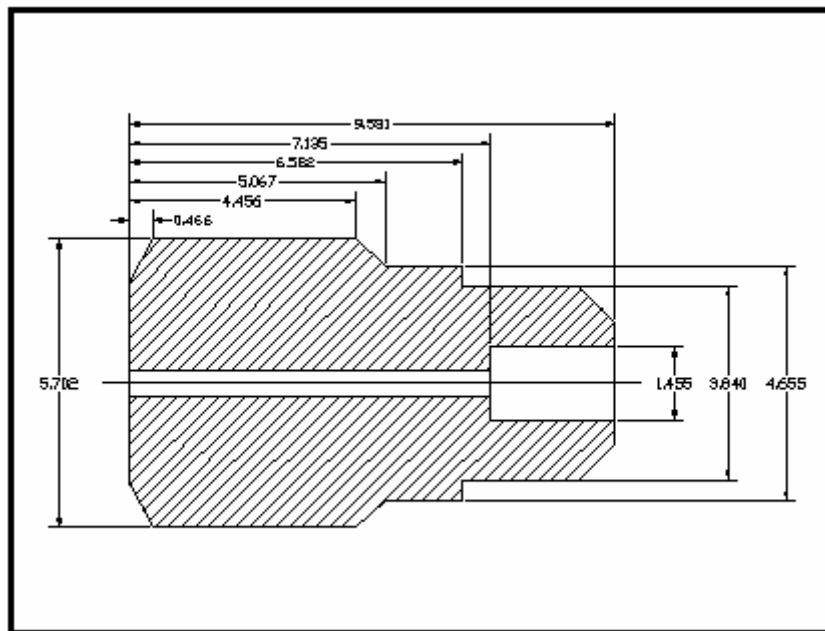

- A  Letter “C” for Continuous
- B  Letter “S” for Staggered
- C  Letter “B” for Baseline
- D  None of the above



**Kean University**  
1000 Morris Avenue  
Union, New Jersey 07083

## AutoCAD® Achievement Examination

Continuing Professional Education  
Advanced Computer Technology Center ACTC  
Nathan Weiss College of Graduate Studies

### Question 71

In the image below, the operator just invoked the Linetype dialog box. The operator needs to place a Centerline on the drawing. There are only two linetypes currently listed in the box. Which option needs to be executed to add additional linetypes?

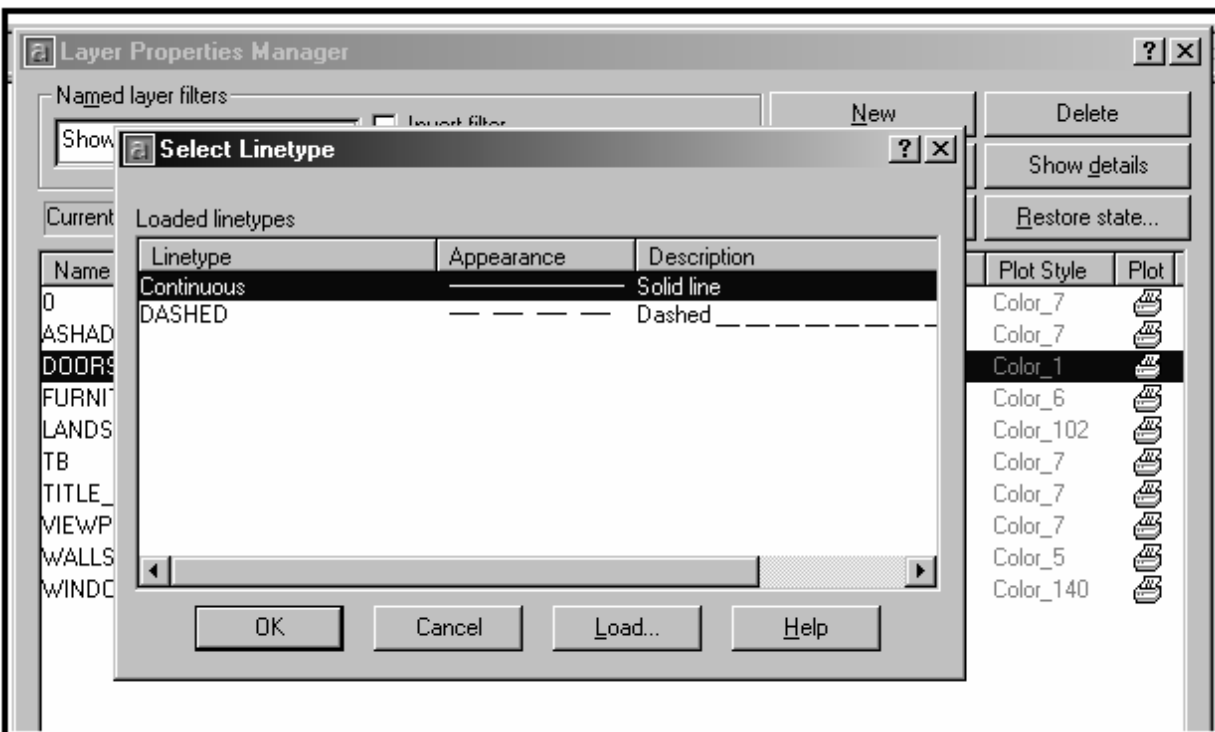

- A  Restore
- B  OK
- C  Cancel
- D  Load



**Kean University**  
1000 Morris Avenue  
Union, New Jersey 07083

## AutoCAD<sup>®</sup> Achievement Examination

Continuing Professional Education  
Advanced Computer Technology Center ACTC  
Nathan Weiss College of Graduate Studies

### Question 72

The operator for this assembly drawing established four Layers. From the answer selection below choose the most appropriate choice of layer names.

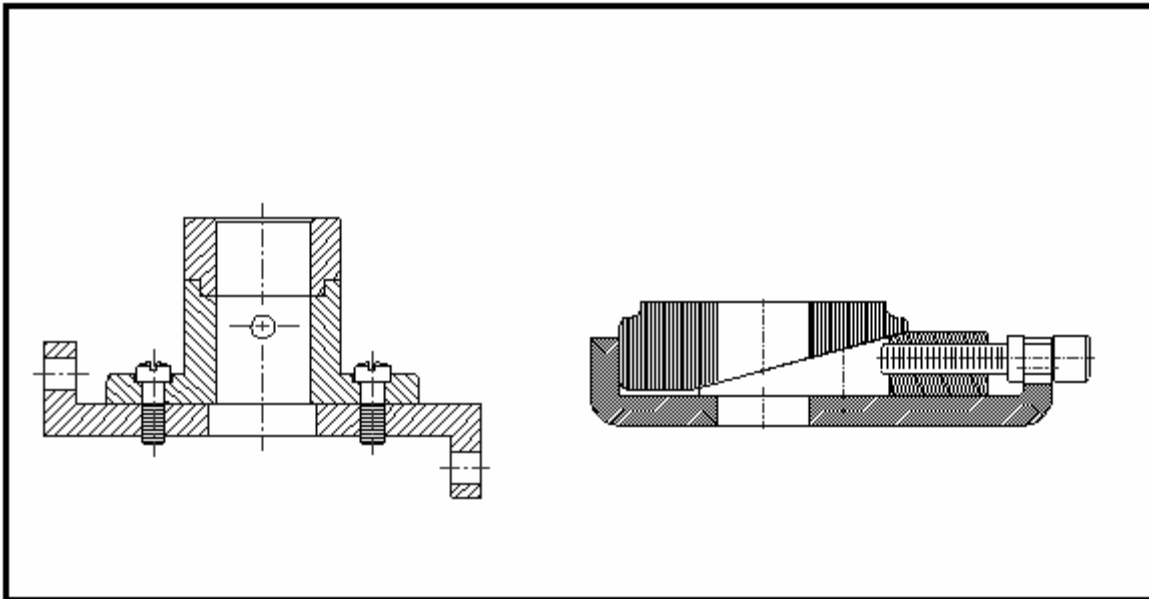

- A  Nuts, Bolts, Doors, Windows
- B  Screws, Bolts, Bearings
- C  Screws, Lower Bracket, Upper Bracket, Bushing
- D  Faucets, Handles, Sinks, Pipes

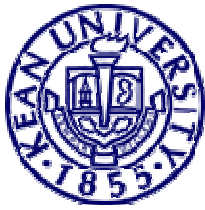

**Kean University**  
1000 Morris Avenue  
Union, New Jersey 07083

## AutoCAD® Achievement Examination

Continuing Professional Education  
Advanced Computer Technology Center ACTC  
Nathan Weiss College of Graduate Studies

### Question 73

What AutoCAD command does this menu belongs to?

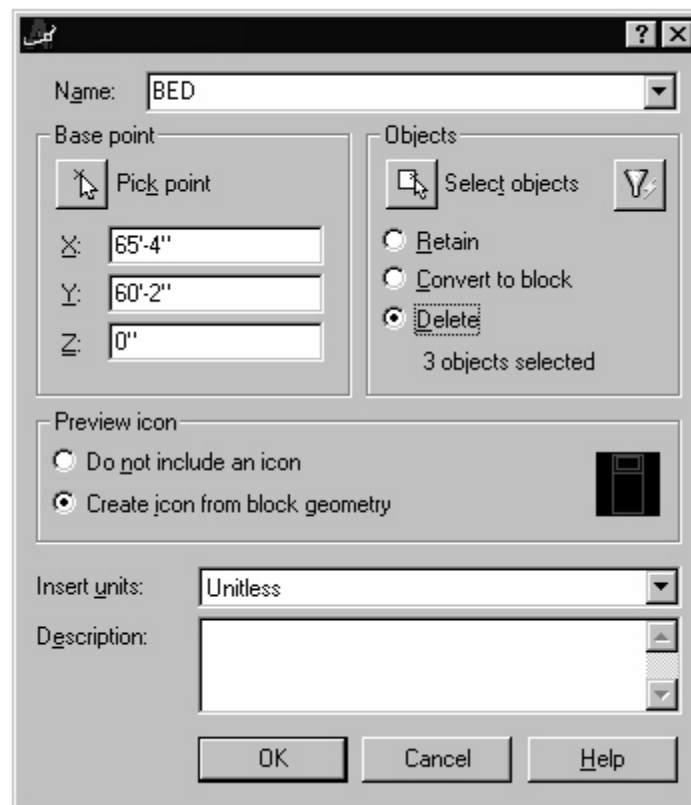

- A  Creating line types
- B  Block definition
- C  Creating circles
- D  Creating rectangles



**Kean University**  
1000 Morris Avenue  
Union, New Jersey 07083

## AutoCAD® Achievement Examination

Continuing Professional Education  
Advanced Computer Technology Center ACTC  
Nathan Weiss College of Graduate Studies

### Question 74

One of the choices from the INSERT command was just invoked by the operator. Looking at the dialog box below, name the command option that was selected from the INSERT pop-down menu?

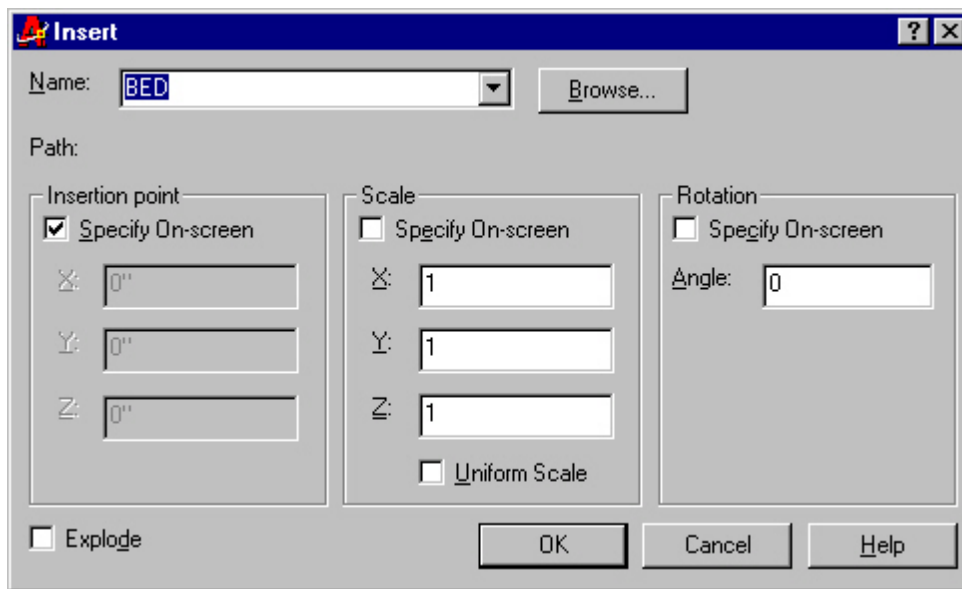

- A  Creating linetypes
- B  External references
- C  Hyperlink
- D  Block



**Kean University**  
1000 Morris Avenue  
Union, New Jersey 07083

## AutoCAD® Achievement Examination

Continuing Professional Education  
Advanced Computer Technology Center ACTC  
Nathan Weiss College of Graduate Studies

### Question 75

The dialog box below was selected to create “Intelligent” Blocks. What is generally meant, in AutoCAD terminology as “Intelligent Block”?

The dialog box is titled 'Block Definition' and contains the following sections:

- Mode:**
  - Invisible
  - Constant
  - Verify
  - Preset
- Attribute:**
  - Tag: PART\_NUMBER
  - Prompt: Enter part number:
  - Value: (empty field)
- Insertion Point:**
  - Pick Point < (button)
  - X: 0"
  - Y: 0"
  - Z: 0"
- Text Options:**
  - Justification: Center
  - Text Style: STANDARD
  - Height <: 6'
  - Rotation <: 0
- Align below previous attribute definition

Buttons at the bottom: OK, Cancel, Help.

- A  Blocks that can think
- B  Blocks with text attributes
- C  2 x 4 blocks with automatic dimensions
- D  Writer's block

## Appendix B

### Objective Student Satisfaction Inventory Form E

# Instructional Assessment System

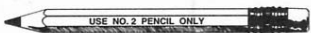

USE NO. 2 PENCIL ONLY

ADDITIONAL ITEMS  
Use only if fit into bubbles

FORM  
**E**

Fill in bubbles darkly and completely.  
Erase errors cleanly.

---

Instructor \_\_\_\_\_ Course \_\_\_\_\_ Section \_\_\_\_\_ Date \_\_\_\_\_

**Completion of this questionnaire is voluntary. You are free to leave some or all questions unanswered.**

	1	2	3	4	5	6	7	8	9	10	11	12	13	14	15	16	17	18	19	20	21	22		
	Excel-    Very    Good    Fair    Poor    Very lent    Good																							
1. The course as a whole was:	<input type="radio"/>	<input type="radio"/>	<input type="radio"/>	<input type="radio"/>	<input type="radio"/>	<input type="radio"/>	<input type="radio"/>	<input type="radio"/>	<input type="radio"/>	<input type="radio"/>	<input type="radio"/>	<input type="radio"/>	<input type="radio"/>	<input type="radio"/>	<input type="radio"/>	<input type="radio"/>	<input type="radio"/>	<input type="radio"/>	<input type="radio"/>	<input type="radio"/>	<input type="radio"/>	<input type="radio"/>	<input type="radio"/>	
2. The course content was:	<input type="radio"/>	<input type="radio"/>	<input type="radio"/>	<input type="radio"/>	<input type="radio"/>	<input type="radio"/>	<input type="radio"/>	<input type="radio"/>	<input type="radio"/>	<input type="radio"/>	<input type="radio"/>	<input type="radio"/>	<input type="radio"/>	<input type="radio"/>	<input type="radio"/>	<input type="radio"/>	<input type="radio"/>	<input type="radio"/>	<input type="radio"/>	<input type="radio"/>	<input type="radio"/>	<input type="radio"/>	<input type="radio"/>	
3. The instructor's contribution to the course was:	<input type="radio"/>	<input type="radio"/>	<input type="radio"/>	<input type="radio"/>	<input type="radio"/>	<input type="radio"/>	<input type="radio"/>	<input type="radio"/>	<input type="radio"/>	<input type="radio"/>	<input type="radio"/>	<input type="radio"/>	<input type="radio"/>	<input type="radio"/>	<input type="radio"/>	<input type="radio"/>	<input type="radio"/>	<input type="radio"/>	<input type="radio"/>	<input type="radio"/>	<input type="radio"/>	<input type="radio"/>	<input type="radio"/>	
4. The instructor's effectiveness in teaching the subject matter was:	<input type="radio"/>	<input type="radio"/>	<input type="radio"/>	<input type="radio"/>	<input type="radio"/>	<input type="radio"/>	<input type="radio"/>	<input type="radio"/>	<input type="radio"/>	<input type="radio"/>	<input type="radio"/>	<input type="radio"/>	<input type="radio"/>	<input type="radio"/>	<input type="radio"/>	<input type="radio"/>	<input type="radio"/>	<input type="radio"/>	<input type="radio"/>	<input type="radio"/>	<input type="radio"/>	<input type="radio"/>	<input type="radio"/>	
5. Opportunity for practicing what was learned was:	<input type="radio"/>	<input type="radio"/>	<input type="radio"/>	<input type="radio"/>	<input type="radio"/>	<input type="radio"/>	<input type="radio"/>	<input type="radio"/>	<input type="radio"/>	<input type="radio"/>	<input type="radio"/>	<input type="radio"/>	<input type="radio"/>	<input type="radio"/>	<input type="radio"/>	<input type="radio"/>	<input type="radio"/>	<input type="radio"/>	<input type="radio"/>	<input type="radio"/>	<input type="radio"/>	<input type="radio"/>	<input type="radio"/>	
6. Sequential development of skills was:	<input type="radio"/>	<input type="radio"/>	<input type="radio"/>	<input type="radio"/>	<input type="radio"/>	<input type="radio"/>	<input type="radio"/>	<input type="radio"/>	<input type="radio"/>	<input type="radio"/>	<input type="radio"/>	<input type="radio"/>	<input type="radio"/>	<input type="radio"/>	<input type="radio"/>	<input type="radio"/>	<input type="radio"/>	<input type="radio"/>	<input type="radio"/>	<input type="radio"/>	<input type="radio"/>	<input type="radio"/>	<input type="radio"/>	
7. Explanations of underlying rationales for new techniques or skills were:	<input type="radio"/>	<input type="radio"/>	<input type="radio"/>	<input type="radio"/>	<input type="radio"/>	<input type="radio"/>	<input type="radio"/>	<input type="radio"/>	<input type="radio"/>	<input type="radio"/>	<input type="radio"/>	<input type="radio"/>	<input type="radio"/>	<input type="radio"/>	<input type="radio"/>	<input type="radio"/>	<input type="radio"/>	<input type="radio"/>	<input type="radio"/>	<input type="radio"/>	<input type="radio"/>	<input type="radio"/>	<input type="radio"/>	
8. Demonstrations of expected skills were:	<input type="radio"/>	<input type="radio"/>	<input type="radio"/>	<input type="radio"/>	<input type="radio"/>	<input type="radio"/>	<input type="radio"/>	<input type="radio"/>	<input type="radio"/>	<input type="radio"/>	<input type="radio"/>	<input type="radio"/>	<input type="radio"/>	<input type="radio"/>	<input type="radio"/>	<input type="radio"/>	<input type="radio"/>	<input type="radio"/>	<input type="radio"/>	<input type="radio"/>	<input type="radio"/>	<input type="radio"/>	<input type="radio"/>	
9. Instructor's confidence in students' ability was:	<input type="radio"/>	<input type="radio"/>	<input type="radio"/>	<input type="radio"/>	<input type="radio"/>	<input type="radio"/>	<input type="radio"/>	<input type="radio"/>	<input type="radio"/>	<input type="radio"/>	<input type="radio"/>	<input type="radio"/>	<input type="radio"/>	<input type="radio"/>	<input type="radio"/>	<input type="radio"/>	<input type="radio"/>	<input type="radio"/>	<input type="radio"/>	<input type="radio"/>	<input type="radio"/>	<input type="radio"/>	<input type="radio"/>	
10. Recognition of student progress by instructor was:	<input type="radio"/>	<input type="radio"/>	<input type="radio"/>	<input type="radio"/>	<input type="radio"/>	<input type="radio"/>	<input type="radio"/>	<input type="radio"/>	<input type="radio"/>	<input type="radio"/>	<input type="radio"/>	<input type="radio"/>	<input type="radio"/>	<input type="radio"/>	<input type="radio"/>	<input type="radio"/>	<input type="radio"/>	<input type="radio"/>	<input type="radio"/>	<input type="radio"/>	<input type="radio"/>	<input type="radio"/>	<input type="radio"/>	
11. Student confidence in instructor's knowledge was:	<input type="radio"/>	<input type="radio"/>	<input type="radio"/>	<input type="radio"/>	<input type="radio"/>	<input type="radio"/>	<input type="radio"/>	<input type="radio"/>	<input type="radio"/>	<input type="radio"/>	<input type="radio"/>	<input type="radio"/>	<input type="radio"/>	<input type="radio"/>	<input type="radio"/>	<input type="radio"/>	<input type="radio"/>	<input type="radio"/>	<input type="radio"/>	<input type="radio"/>	<input type="radio"/>	<input type="radio"/>	<input type="radio"/>	
12. Freedom allowed students to develop own skills and ideas was:	<input type="radio"/>	<input type="radio"/>	<input type="radio"/>	<input type="radio"/>	<input type="radio"/>	<input type="radio"/>	<input type="radio"/>	<input type="radio"/>	<input type="radio"/>	<input type="radio"/>	<input type="radio"/>	<input type="radio"/>	<input type="radio"/>	<input type="radio"/>	<input type="radio"/>	<input type="radio"/>	<input type="radio"/>	<input type="radio"/>	<input type="radio"/>	<input type="radio"/>	<input type="radio"/>	<input type="radio"/>	<input type="radio"/>	
13. Instructor's ability to deal with student difficulties was:	<input type="radio"/>	<input type="radio"/>	<input type="radio"/>	<input type="radio"/>	<input type="radio"/>	<input type="radio"/>	<input type="radio"/>	<input type="radio"/>	<input type="radio"/>	<input type="radio"/>	<input type="radio"/>	<input type="radio"/>	<input type="radio"/>	<input type="radio"/>	<input type="radio"/>	<input type="radio"/>	<input type="radio"/>	<input type="radio"/>	<input type="radio"/>	<input type="radio"/>	<input type="radio"/>	<input type="radio"/>	<input type="radio"/>	
14. Tailoring of instruction to varying student skill levels was:	<input type="radio"/>	<input type="radio"/>	<input type="radio"/>	<input type="radio"/>	<input type="radio"/>	<input type="radio"/>	<input type="radio"/>	<input type="radio"/>	<input type="radio"/>	<input type="radio"/>	<input type="radio"/>	<input type="radio"/>	<input type="radio"/>	<input type="radio"/>	<input type="radio"/>	<input type="radio"/>	<input type="radio"/>	<input type="radio"/>	<input type="radio"/>	<input type="radio"/>	<input type="radio"/>	<input type="radio"/>	<input type="radio"/>	
15. Availability of extra help when needed was:	<input type="radio"/>	<input type="radio"/>	<input type="radio"/>	<input type="radio"/>	<input type="radio"/>	<input type="radio"/>	<input type="radio"/>	<input type="radio"/>	<input type="radio"/>	<input type="radio"/>	<input type="radio"/>	<input type="radio"/>	<input type="radio"/>	<input type="radio"/>	<input type="radio"/>	<input type="radio"/>	<input type="radio"/>	<input type="radio"/>	<input type="radio"/>	<input type="radio"/>	<input type="radio"/>	<input type="radio"/>	<input type="radio"/>	
16. Use of class time was:	<input type="radio"/>	<input type="radio"/>	<input type="radio"/>	<input type="radio"/>	<input type="radio"/>	<input type="radio"/>	<input type="radio"/>	<input type="radio"/>	<input type="radio"/>	<input type="radio"/>	<input type="radio"/>	<input type="radio"/>	<input type="radio"/>	<input type="radio"/>	<input type="radio"/>	<input type="radio"/>	<input type="radio"/>	<input type="radio"/>	<input type="radio"/>	<input type="radio"/>	<input type="radio"/>	<input type="radio"/>	<input type="radio"/>	
17. Instructor's interest in whether students learned was:	<input type="radio"/>	<input type="radio"/>	<input type="radio"/>	<input type="radio"/>	<input type="radio"/>	<input type="radio"/>	<input type="radio"/>	<input type="radio"/>	<input type="radio"/>	<input type="radio"/>	<input type="radio"/>	<input type="radio"/>	<input type="radio"/>	<input type="radio"/>	<input type="radio"/>	<input type="radio"/>	<input type="radio"/>	<input type="radio"/>	<input type="radio"/>	<input type="radio"/>	<input type="radio"/>	<input type="radio"/>	<input type="radio"/>	
18. Amount you learned in the course was:	<input type="radio"/>	<input type="radio"/>	<input type="radio"/>	<input type="radio"/>	<input type="radio"/>	<input type="radio"/>	<input type="radio"/>	<input type="radio"/>	<input type="radio"/>	<input type="radio"/>	<input type="radio"/>	<input type="radio"/>	<input type="radio"/>	<input type="radio"/>	<input type="radio"/>	<input type="radio"/>	<input type="radio"/>	<input type="radio"/>	<input type="radio"/>	<input type="radio"/>	<input type="radio"/>	<input type="radio"/>	<input type="radio"/>	
19. Relevance and usefulness of course content were:	<input type="radio"/>	<input type="radio"/>	<input type="radio"/>	<input type="radio"/>	<input type="radio"/>	<input type="radio"/>	<input type="radio"/>	<input type="radio"/>	<input type="radio"/>	<input type="radio"/>	<input type="radio"/>	<input type="radio"/>	<input type="radio"/>	<input type="radio"/>	<input type="radio"/>	<input type="radio"/>	<input type="radio"/>	<input type="radio"/>	<input type="radio"/>	<input type="radio"/>	<input type="radio"/>	<input type="radio"/>	<input type="radio"/>	
20. Evaluative and grading techniques (tests, papers, projects, etc.) were:	<input type="radio"/>	<input type="radio"/>	<input type="radio"/>	<input type="radio"/>	<input type="radio"/>	<input type="radio"/>	<input type="radio"/>	<input type="radio"/>	<input type="radio"/>	<input type="radio"/>	<input type="radio"/>	<input type="radio"/>	<input type="radio"/>	<input type="radio"/>	<input type="radio"/>	<input type="radio"/>	<input type="radio"/>	<input type="radio"/>	<input type="radio"/>	<input type="radio"/>	<input type="radio"/>	<input type="radio"/>	<input type="radio"/>	
21. Reasonableness of assigned work was:	<input type="radio"/>	<input type="radio"/>	<input type="radio"/>	<input type="radio"/>	<input type="radio"/>	<input type="radio"/>	<input type="radio"/>	<input type="radio"/>	<input type="radio"/>	<input type="radio"/>	<input type="radio"/>	<input type="radio"/>	<input type="radio"/>	<input type="radio"/>	<input type="radio"/>	<input type="radio"/>	<input type="radio"/>	<input type="radio"/>	<input type="radio"/>	<input type="radio"/>	<input type="radio"/>	<input type="radio"/>	<input type="radio"/>	
22. Clarity of student responsibilities and requirements was:	<input type="radio"/>	<input type="radio"/>	<input type="radio"/>	<input type="radio"/>	<input type="radio"/>	<input type="radio"/>	<input type="radio"/>	<input type="radio"/>	<input type="radio"/>	<input type="radio"/>	<input type="radio"/>	<input type="radio"/>	<input type="radio"/>	<input type="radio"/>	<input type="radio"/>	<input type="radio"/>	<input type="radio"/>	<input type="radio"/>	<input type="radio"/>	<input type="radio"/>	<input type="radio"/>	<input type="radio"/>	<input type="radio"/>	
<b>Relative to other college courses you have taken:</b>																								
													Much Higher	Average					Much Lower					
23. Do you expect your grade in this course to be:	<input type="radio"/>	<input type="radio"/>	<input type="radio"/>	<input type="radio"/>	<input type="radio"/>	<input type="radio"/>	<input type="radio"/>	<input type="radio"/>	<input type="radio"/>	<input type="radio"/>	<input type="radio"/>	<input type="radio"/>	<input type="radio"/>	<input type="radio"/>	<input type="radio"/>	<input type="radio"/>	<input type="radio"/>	<input type="radio"/>	<input type="radio"/>	<input type="radio"/>	<input type="radio"/>	<input type="radio"/>	<input type="radio"/>	
24. The intellectual challenge presented was:	<input type="radio"/>	<input type="radio"/>	<input type="radio"/>	<input type="radio"/>	<input type="radio"/>	<input type="radio"/>	<input type="radio"/>	<input type="radio"/>	<input type="radio"/>	<input type="radio"/>	<input type="radio"/>	<input type="radio"/>	<input type="radio"/>	<input type="radio"/>	<input type="radio"/>	<input type="radio"/>	<input type="radio"/>	<input type="radio"/>	<input type="radio"/>	<input type="radio"/>	<input type="radio"/>	<input type="radio"/>	<input type="radio"/>	
25. The amount of effort you put into this course was:	<input type="radio"/>	<input type="radio"/>	<input type="radio"/>	<input type="radio"/>	<input type="radio"/>	<input type="radio"/>	<input type="radio"/>	<input type="radio"/>	<input type="radio"/>	<input type="radio"/>	<input type="radio"/>	<input type="radio"/>	<input type="radio"/>	<input type="radio"/>	<input type="radio"/>	<input type="radio"/>	<input type="radio"/>	<input type="radio"/>	<input type="radio"/>	<input type="radio"/>	<input type="radio"/>	<input type="radio"/>	<input type="radio"/>	
26. The amount of effort to succeed in this course was:	<input type="radio"/>	<input type="radio"/>	<input type="radio"/>	<input type="radio"/>	<input type="radio"/>	<input type="radio"/>	<input type="radio"/>	<input type="radio"/>	<input type="radio"/>	<input type="radio"/>	<input type="radio"/>	<input type="radio"/>	<input type="radio"/>	<input type="radio"/>	<input type="radio"/>	<input type="radio"/>	<input type="radio"/>	<input type="radio"/>	<input type="radio"/>	<input type="radio"/>	<input type="radio"/>	<input type="radio"/>	<input type="radio"/>	
27. Your involvement in this course (doing assignments, attending classes, etc.) was:	<input type="radio"/>	<input type="radio"/>	<input type="radio"/>	<input type="radio"/>	<input type="radio"/>	<input type="radio"/>	<input type="radio"/>	<input type="radio"/>	<input type="radio"/>	<input type="radio"/>	<input type="radio"/>	<input type="radio"/>	<input type="radio"/>	<input type="radio"/>	<input type="radio"/>	<input type="radio"/>	<input type="radio"/>	<input type="radio"/>	<input type="radio"/>	<input type="radio"/>	<input type="radio"/>	<input type="radio"/>	<input type="radio"/>	
28. On average, how many hours per week have you spent on this course, including attending classes, doing readings, reviewing notes, writing papers and any other course related work?	<input type="radio"/> Under 2	<input type="radio"/> 2 - 3	<input type="radio"/> 4 - 5	<input type="radio"/> 6 - 7	<input type="radio"/> 8 - 9	<input type="radio"/> 10 - 11	<input type="radio"/> 12 - 13	<input type="radio"/> 14 - 15	<input type="radio"/> 16 - 17	<input type="radio"/> 18 - 19	<input type="radio"/> 20 - 21	<input type="radio"/> 22 or more	<input type="radio"/>	<input type="radio"/>	<input type="radio"/>	<input type="radio"/>	<input type="radio"/>	<input type="radio"/>	<input type="radio"/>	<input type="radio"/>	<input type="radio"/>	<input type="radio"/>	<input type="radio"/>	
29. From the total average hours above, how many do you consider were valuable in advancing your education?	<input type="radio"/> Under 2	<input type="radio"/> 2 - 3	<input type="radio"/> 4 - 5	<input type="radio"/> 6 - 7	<input type="radio"/> 8 - 9	<input type="radio"/> 10 - 11	<input type="radio"/> 12 - 13	<input type="radio"/> 14 - 15	<input type="radio"/> 16 - 17	<input type="radio"/> 18 - 19	<input type="radio"/> 20 - 21	<input type="radio"/> 22 or more	<input type="radio"/>	<input type="radio"/>	<input type="radio"/>	<input type="radio"/>	<input type="radio"/>	<input type="radio"/>	<input type="radio"/>	<input type="radio"/>	<input type="radio"/>	<input type="radio"/>	<input type="radio"/>	
30. What grade do you expect in this course?	<input type="radio"/> A (3.9-4.0)	<input type="radio"/> A- (3.5-3.8)	<input type="radio"/> B+ (3.2-3.4)	<input type="radio"/> B (2.9-3.1)	<input type="radio"/> B- (2.5-2.8)	<input type="radio"/> C+ (2.2-2.4)	<input type="radio"/> C (1.9-2.1)	<input type="radio"/> C- (1.5-1.8)	<input type="radio"/> D+ (1.2-1.4)	<input type="radio"/> D (0.9-1.1)	<input type="radio"/> D- (0.7-0.8)	<input type="radio"/> E (0.0)	<input type="radio"/> Pass	<input type="radio"/> Credit	<input type="radio"/> No Credit	<input type="radio"/>	<input type="radio"/>	<input type="radio"/>	<input type="radio"/>	<input type="radio"/>	<input type="radio"/>	<input type="radio"/>	<input type="radio"/>	
31. In regard to your academic program, is this course best described as:	<input type="radio"/> In your major?	<input type="radio"/> In your minor?	<input type="radio"/>	<input type="radio"/> A distribution requirement?	<input type="radio"/> A program requirement?	<input type="radio"/>	<input type="radio"/> An elective?	<input type="radio"/> Other?	<input type="radio"/>	<input type="radio"/>	<input type="radio"/>	<input type="radio"/>	<input type="radio"/>	<input type="radio"/>	<input type="radio"/>	<input type="radio"/>	<input type="radio"/>	<input type="radio"/>	<input type="radio"/>	<input type="radio"/>	<input type="radio"/>	<input type="radio"/>	<input type="radio"/>	

---

Mark Reflex® by NCS MM89762-2 15141312 ED06 Printed in U.S.A.
©1995, University of Washington - Office of Educational Assessment

## Appendix C



Continuing Professional Education  
Advanced Computer Technology Center ACTC  
Nathan Weiss College of Graduate Studies

---

# **AutoCAD<sup>®</sup> Achievement Examination**

## Section Test Modules - A101, A102, and A103

### List of Assessment Objectives

#### ***Instruction***

This AutoCAD Achievement Examination is a series of three segment tests, covering the content volume of the standard AutoCAD I course, conducted at ACTC Professional Continuing Education Center, in the Department of Technology. Please rate the examinations as compared with the list of objectives below. The examinations and a special Likert-type scale rating sheets should be included with this document.

### **Section Test Module I - A101**

#### ***Basic Drawing Techniques and Procedures***

This test module will assess students' beginning knowledge as well as ability to create basic drawings using AutoCAD design program. The test is designed to assess the following body of instruction:

1. Drawing LINES, ARCS, CIRCLES, and POLYGONS
2. Basic Cross-hatching techniques
3. Using OFFSET command for lines and circles
4. Identifying AutoCAD commands, menus, icon toolbars and Function keys
5. Using TRIM command
6. Basic Dimensioning techniques, including Linear, Radial, and Aligned modes
7. Using FILLET command in a variety of applications
8. General understanding of Drafting practices



## **Section Test Module I - A102**

### *Basic Modifying Techniques and Procedures*

This test module will assess students' beginning knowledge as well as ability to perform a variety of modifications and manipulations of created entities. The test is designed to assess the following body of instruction:

1. Using COPY and MOVE commands
2. Using MIRROR and ROTATE commands
3. Using Rectangular & Polar ARRAY command
4. Identifying standard AutoCAD menus and icon toolbars
5. Using SCALE command
6. Using EXTEND and BREAK command
7. Using CHAMFER command
8. General Dimensioning and Drafting Practices

## **Section Test Module I - A103**

### *Advanced AutoCAD Techniques and Procedures*

This test module will assess students' knowledge as well as ability perform a variety of more advanced procedures, related mostly to organization of the drawing, as well as a variety of time-saving techniques. The test is designed to assess the following body of instruction:

1. Understanding LAYER command process
2. Understanding LINETYPE applications and procedures
3. Creating and using TEXT STYLES
4. Using and applying MTEXT command
5. Using Quick Dimensioning (QDIM) techniques
6. Drawing Layout Procedures and Practices
7. Utilization of PAPER and MODEL SPACE procedures
8. Working with BLOCKS

Rater's Name: \_\_\_\_\_

Date: \_\_\_\_\_



## Appendix D

### Rating Form. Test Module A101 Questions 1-25

Please rate the performance of test items specified in comparison to the included objective list, using Likert-type scale below. The questions are listed in the order of the objectives they are supposed to measure. This rating scale is to be used with the Test Module A101, and the included Objective List.

No.	Rating Description	Excel- lent	Very Good	Good	Fair	Poor	Very Poor
1	Question 14 against Objective 1	1	1	1	1	1	1
2	Question 15 against Objective 1	1	1	1	1	1	1
3	Question 16 against Objective 1	1	1	1	1	1	1
4	Question 17 against Objective 1	1	1	1	1	1	1
5	Question 23 against Objective 1	1	1	1	1	1	1
6	Question 1 against Objective 2	1	1	1	1	1	1
7	Question 4 against Objective 3	1	1	1	1	1	1
8	Question 2 against Objective 3	1	1	1	1	1	1
9	Question 3 against Objective 4	1	1	1	1	1	1
10	Question 24 against Objective 4	1	1	1	1	1	1
11	Question 25 against Objective 4	1	1	1	1	1	1
12	Question 5 against Objective 5	1	1	1	1	1	1
13	Question 10 against Objective 5	1	1	1	1	1	1
14	Question 6 against Objective 6	1	1	1	1	1	1
15	Question 8 against Objective 6	1	1	1	1	1	1
16	Question 11 against Objective 6	1	1	1	1	1	1
17	Question 12 against Objective 6	1	1	1	1	1	1
18	Question 19 against Objective 6	1	1	1	1	1	1
19	Question 20 against Objective 6	1	1	1	1	1	1
20	Question 7 against Objective 7	1	1	1	1	1	1
21	Question 9 against Objective 7	1	1	1	1	1	1
22	Question 13 against Objective 8	1	1	1	1	1	1
23	Question 18 against Objective 8	1	1	1	1	1	1
24	Question 21 against Objective 8	1	1	1	1	1	1
25	Question 22 against Objective 8	1	1	1	1	1	1

### Rating Form. Test Module A102 Questions 26-50

Please rate the performance of test items specified in comparison to the included objective list, using Likert-type scale below. The questions are listed in the order of the objectives they are supposed to measure. This rating scale is to be used with the Test Module A102, and the included Objective List.

<i>No.</i>	<b>Rating Description</b>	<b>Excel- lent</b>	<b>Very Good</b>	<b>Good</b>	<b>Fair</b>	<b>Poor</b>	<b>Very Poor</b>
1	Question 1 against Objective 1	1	1	1	1	1	1
2	Question 6 against Objective 1	1	1	1	1	1	1
3	Question 16 against Objective 1	1	1	1	1	1	1
4	Question 23 against Objective 1	1	1	1	1	1	1
5	Question 2 against Objective 2	1	1	1	1	1	1
6	Question 9 against Objective 2	1	1	1	1	1	1
7	Question 13 against Objective 2	1	1	1	1	1	1
8	Question 17 against Objective 2	1	1	1	1	1	1
9	Question 4 against Objective 3	1	1	1	1	1	1
10	Question 7 against Objective 3	1	1	1	1	1	1
11	Question 8 against Objective 3	1	1	1	1	1	1
12	Question 14 against Objective 3	1	1	1	1	1	1
13	Question 22 against Objective 3	1	1	1	1	1	1
14	Question 3 against Objective 4	1	1	1	1	1	1
15	Question 5 against Objective 4	1	1	1	1	1	1
16	Question 18 against Objective 4	1	1	1	1	1	1
17	Question 20 against Objective 4	1	1	1	1	1	1
18	Question 10 against Objective 5	1	1	1	1	1	1
19	Question 15 against Objective 5	1	1	1	1	1	1
20	Question 12 against Objective 6	1	1	1	1	1	1
21	Question 19 against Objective 6	1	1	1	1	1	1
22	Question 11 against Objective 7	1	1	1	1	1	1
23	Question 21 against Objective 8	1	1	1	1	1	1
24	Question 24 against Objective 8	1	1	1	1	1	1
25	Question 25 against Objective 8	1	1	1	1	1	1

### Rating Form. Test Module A103 Questions 51-75

Please rate the performance of test items specified in comparison to the included objective list, using Likert-type scale below. The questions are listed in the order of the objectives they are supposed to measure. This rating scale is to be used with the Test Module A103, and the included Objective List.

<i>No.</i>	<b>Rating Description</b>	<b>Excel- lent</b>	<b>Very Good</b>	<b>Good</b>	<b>Fair</b>	<b>Poor</b>	<b>Very Poor</b>
1	Question 1 against Objective 1	1	1	1	1	1	1
2	Question 12 against Objective 1	1	1	1	1	1	1
3	Question 13 against Objective 1	1	1	1	1	1	1
4	Question 22 against Objective 1	1	1	1	1	1	1
5	Question 3 against Objective 2	1	1	1	1	1	1
6	Question 4 against Objective 2	1	1	1	1	1	1
7	Question 14 against Objective 2	1	1	1	1	1	1
8	Question 21 against Objective 2	1	1	1	1	1	1
9	Question 2 against Objective 3	1	1	1	1	1	1
10	Question 8 against Objective 3	1	1	1	1	1	1
11	Question 16 against Objective 3	1	1	1	1	1	1
12	Question 5 against Objective 4	1	1	1	1	1	1
13	Question 15 against Objective 4	1	1	1	1	1	1
14	Question 6 against Objective 5	1	1	1	1	1	1
15	Question 7 against Objective 5	1	1	1	1	1	1
16	Question 20 against Objective 5	1	1	1	1	1	1
17	Question 10 against Objective 6	1	1	1	1	1	1
18	Question 9 against Objective 7	1	1	1	1	1	1
19	Question 11 against Objective 7	1	1	1	1	1	1
20	Question 17 against Objective 7	1	1	1	1	1	1
21	Question 19 against Objective 7	1	1	1	1	1	1
22	Question 18 against Objective 8	1	1	1	1	1	1
23	Question 23 against Objective 8	1	1	1	1	1	1
24	Question 24 against Objective 8	1	1	1	1	1	1
25	Question 25 against Objective 8	1	1	1	1	1	1

## **Appendix E**

### **Cognitive Profile Data** (Pilot Study)

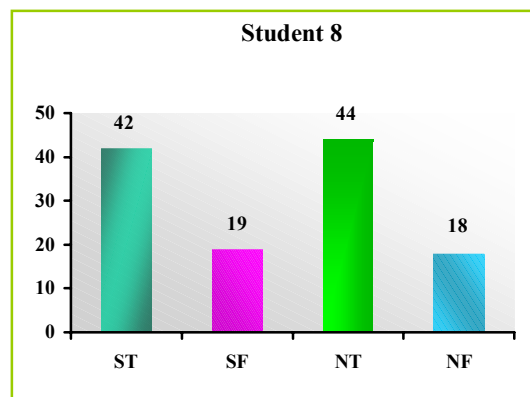
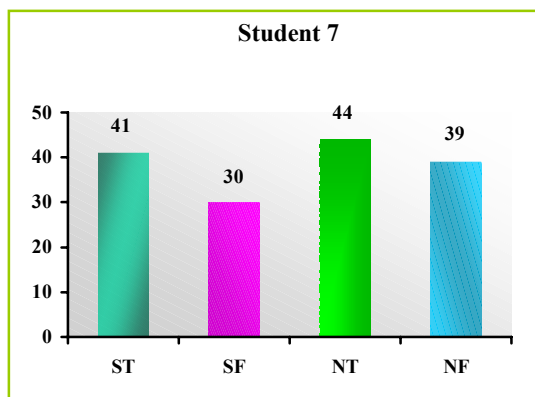
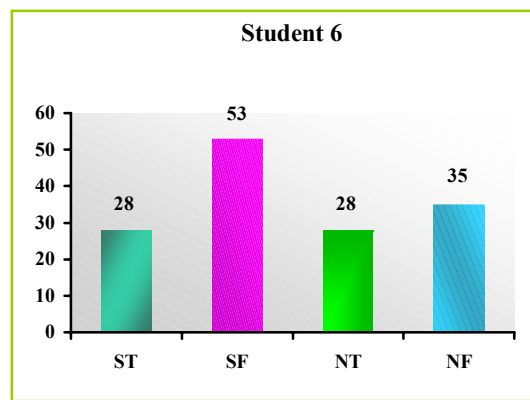
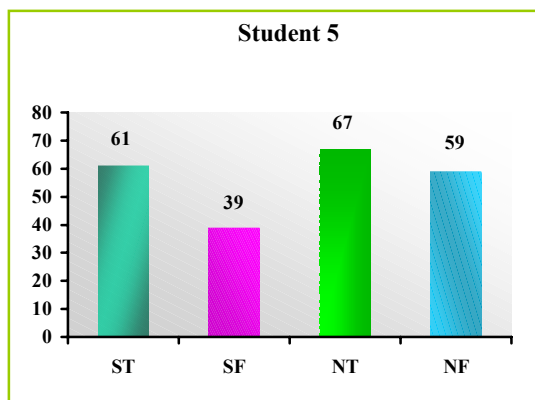
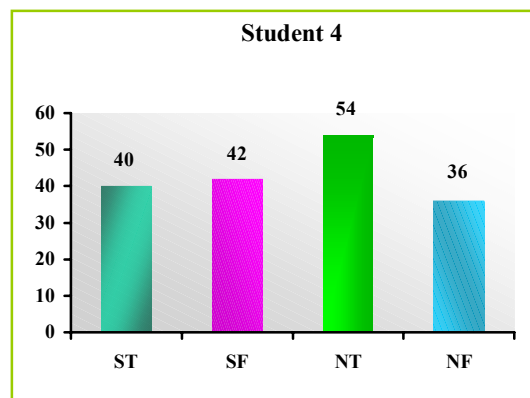
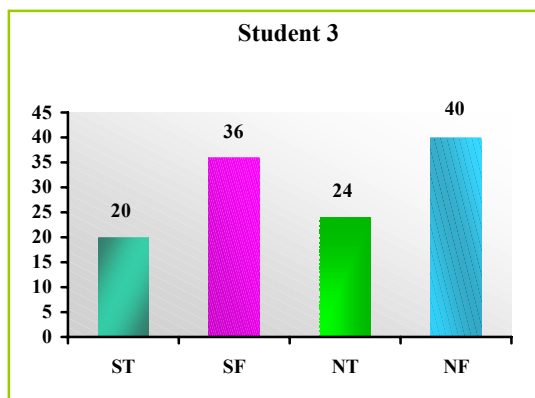
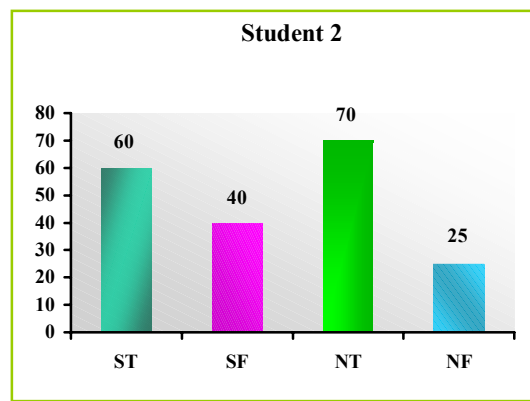
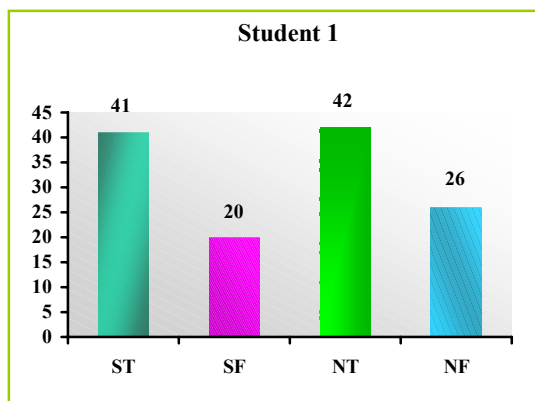

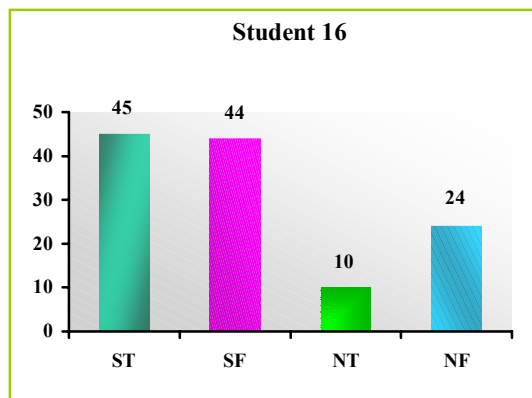
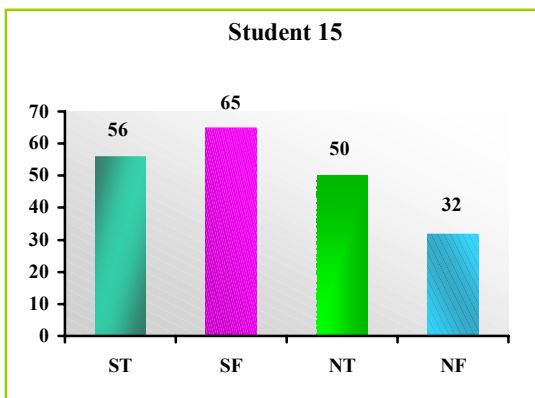
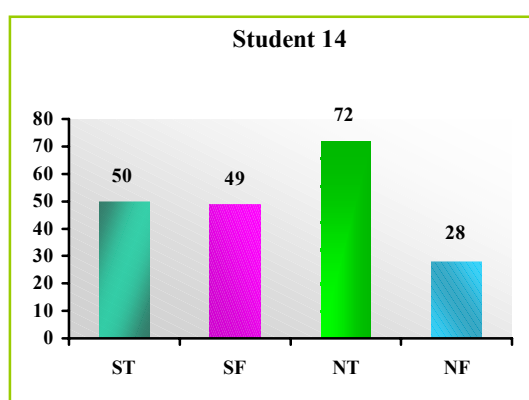
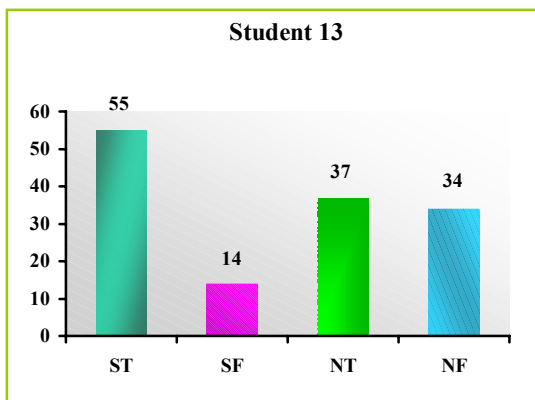
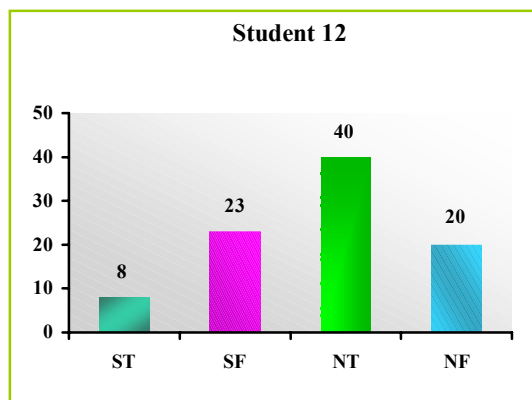
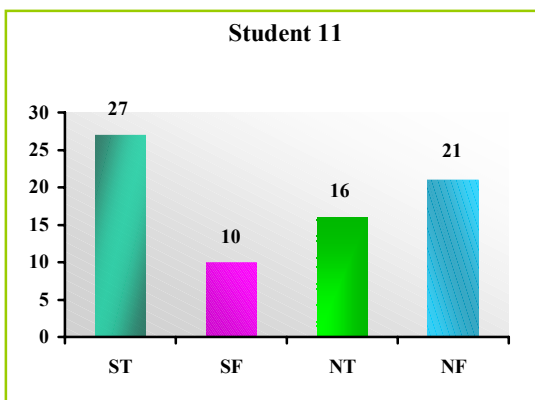
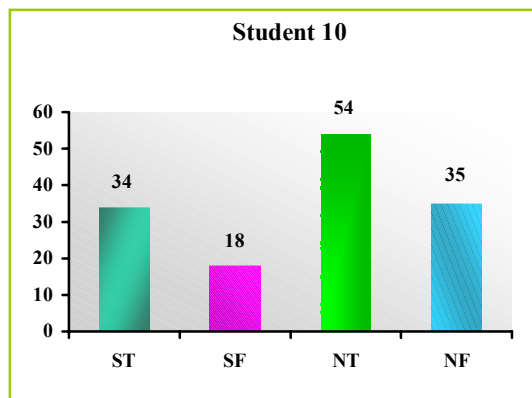
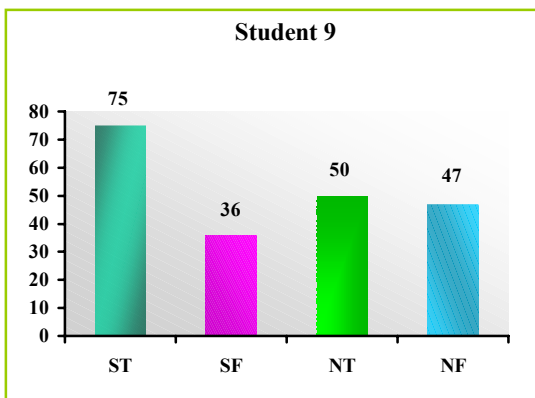

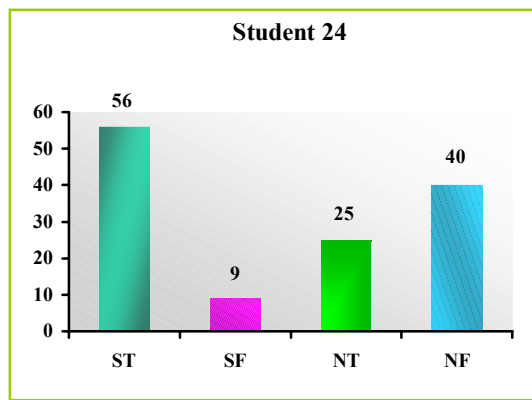
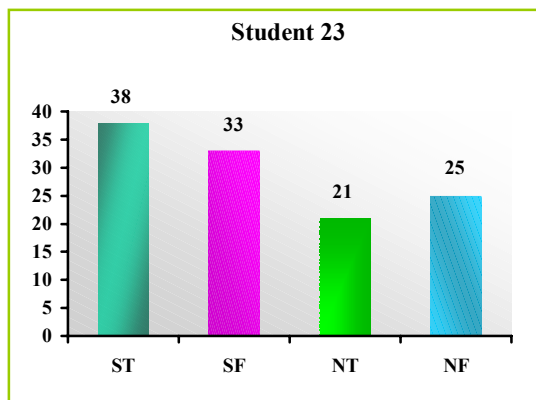
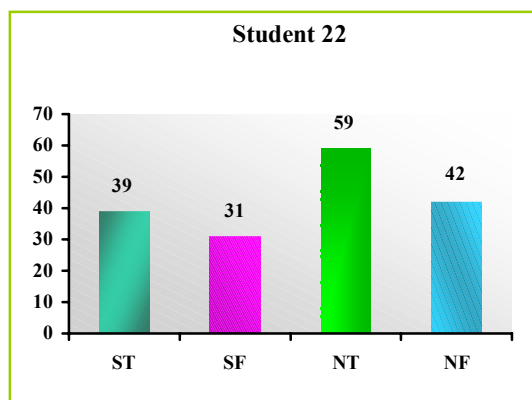
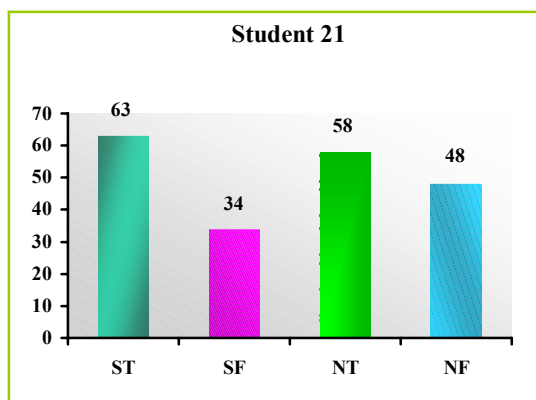
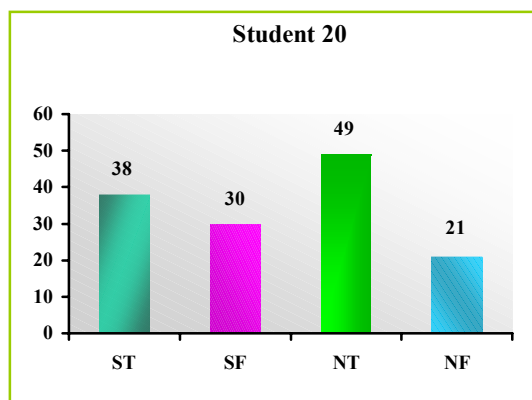
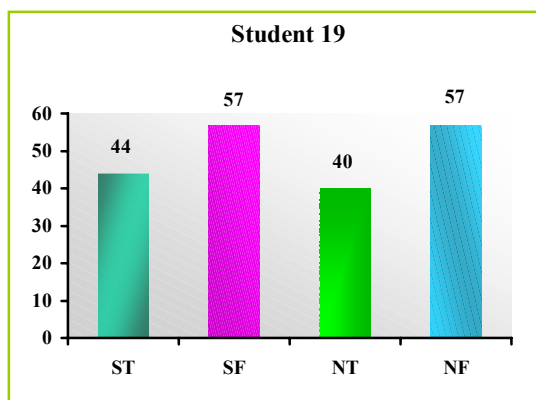
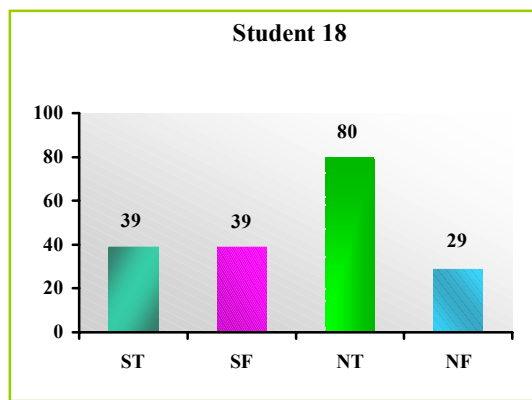
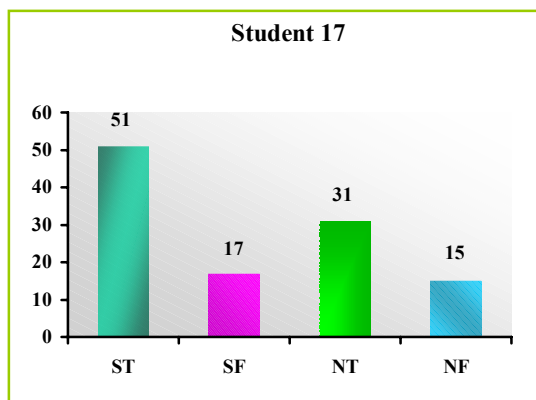



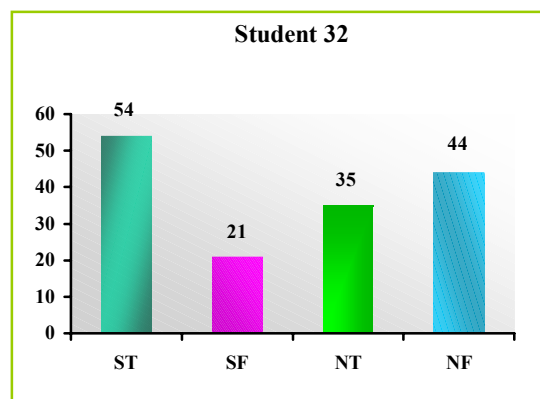
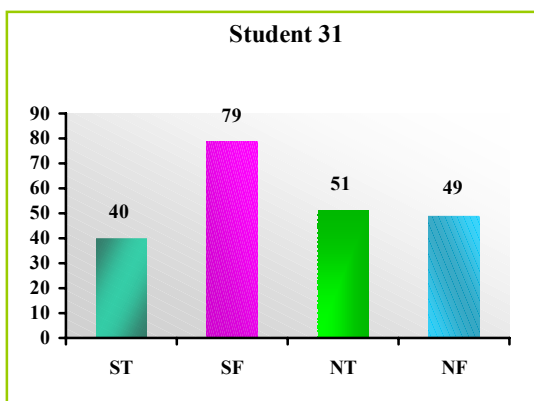
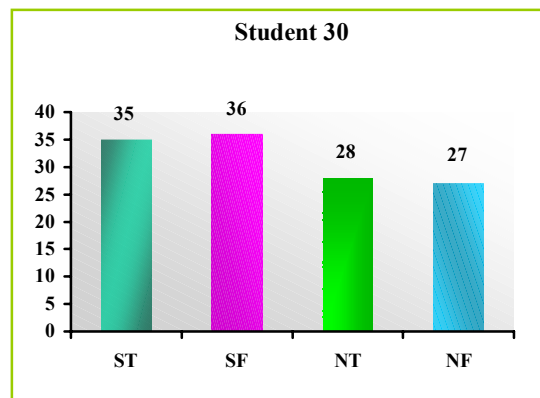
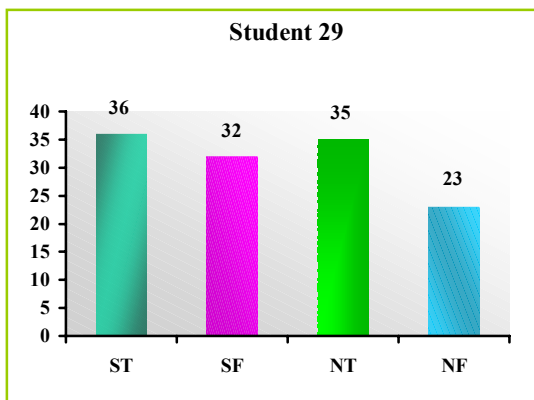
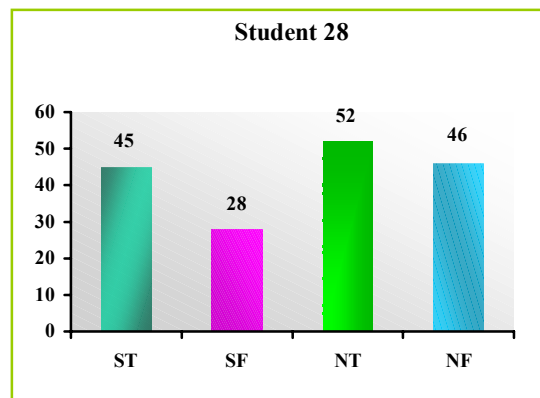
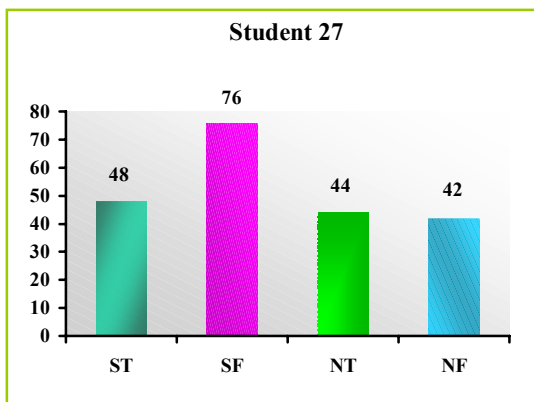
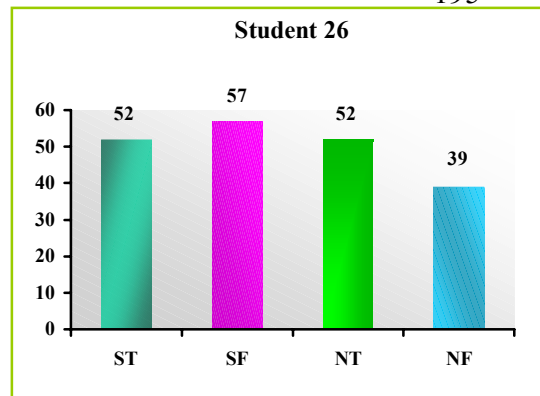
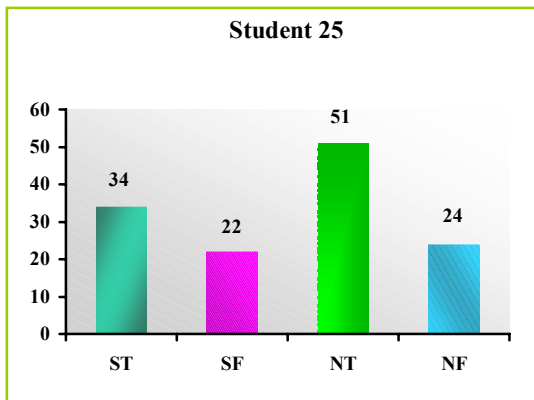

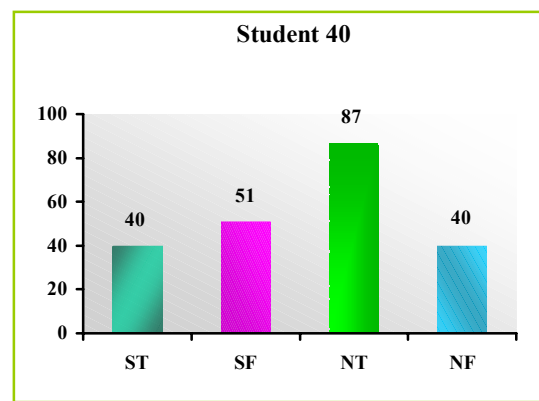
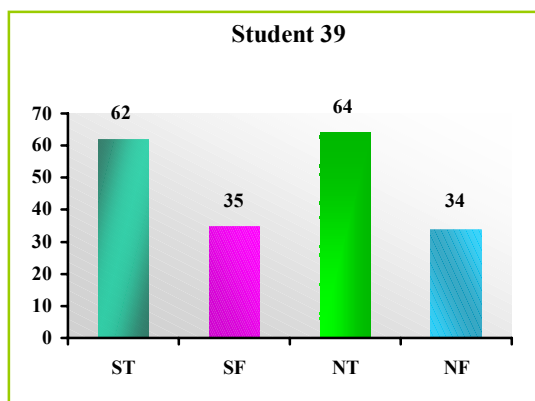
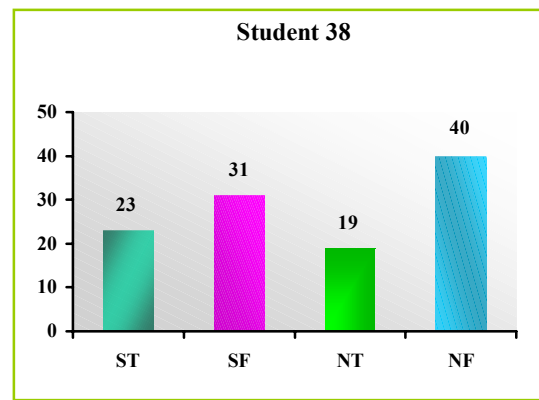
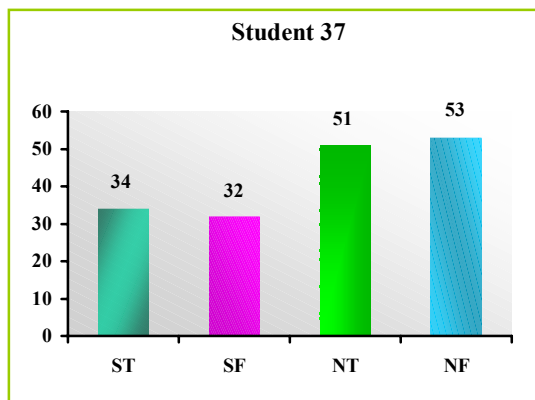
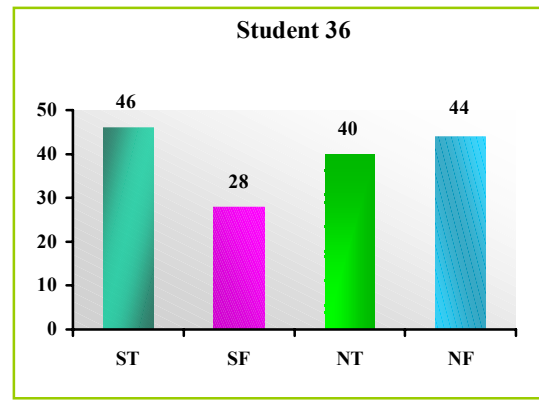
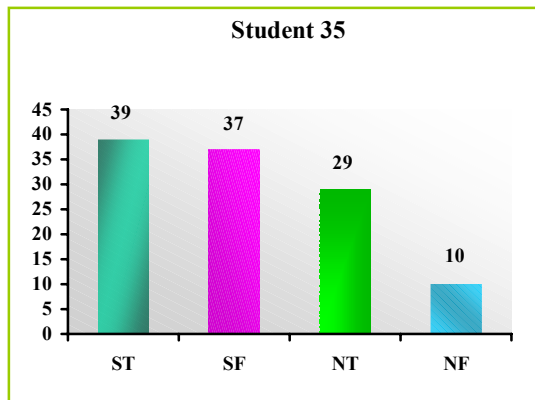
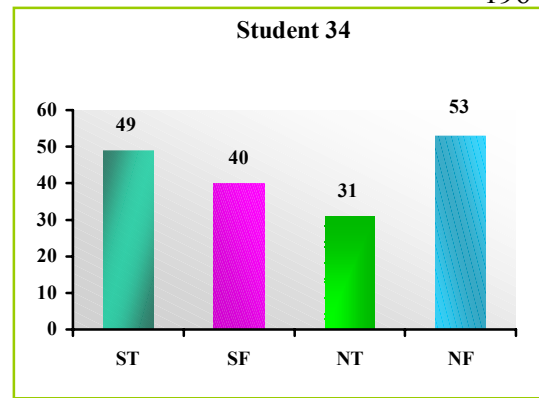
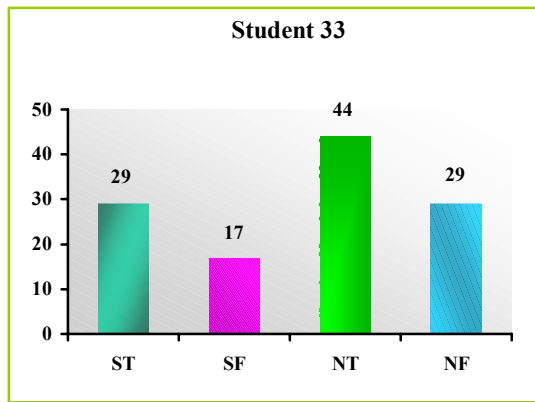

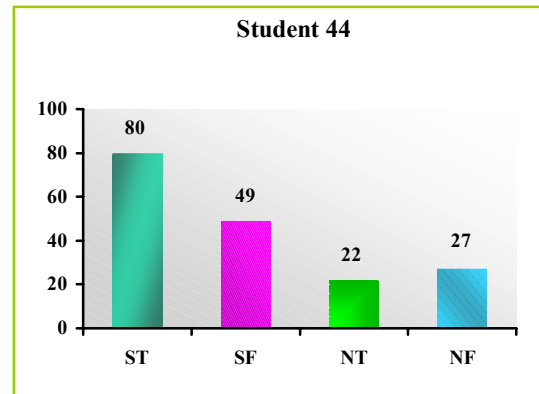
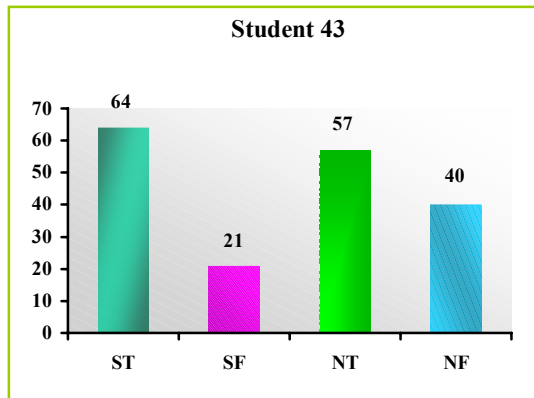
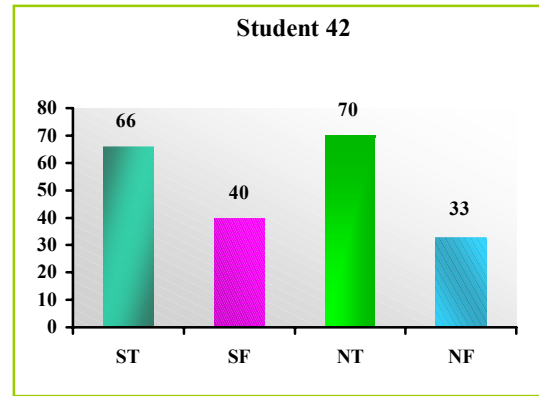
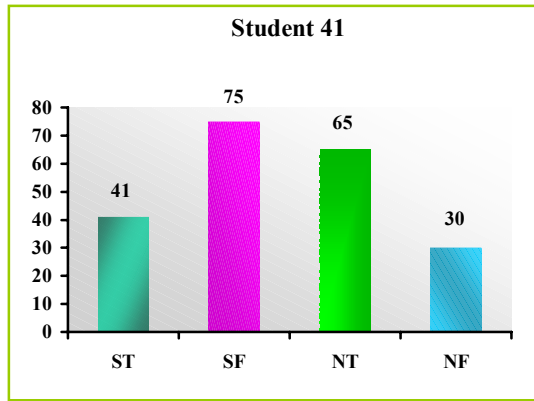

No	ST	SF	NT	NF	Dominant
1	41	20	42	26	NT, ST
2	60	40	70	25	NT, ST
3	20	36	24	40	NF, SF
4	40	42	54	36	NT, SF
5	61	39	67	59	NT, ST
6	28	53	28	35	SF
7	41	30	44	39	NT, ST
8	42	19	44	18	NT, ST
9	75	36	50	47	NT, ST
10	34	18	54	35	NT, NF
11	27	10	16	21	NF, ST
12	8	23	40	20	NT
13	55	14	37	34	NT, ST
14	50	49	72	28	NT, ST
15	56	65	50	32	SF, ST
16	45	44	10	24	SF, ST
17	51	17	31	15	ST
18	39	39	80	29	NT
19	44	57	40	57	NF, SF
20	38	30	49	21	NT
21	63	34	58	48	NT, ST
22	39	31	59	42	NT, NF
23	38	33	21	25	ST, SF
24	56	9	25	40	NF, ST
25	34	22	51	24	NT, SF
26	52	57	52	39	NT
27	48	76	44	42	NT
28	45	28	52	46	NT, NF
29	36	32	35	23	NT, ST
30	35	36	28	27	ST, SF
31	40	79	51	49	SF
32	54	21	35	44	NF, ST
33	29	17	44	29	NT
34	49	40	31	53	NF, ST
35	39	37	29	10	ST, SF
36	46	28	40	44	NF, ST
37	34	32	51	53	NT, NF
38	23	31	19	40	NF
39	62	35	64	34	NT, ST
40	40	51	87	40	NT, SF
41	41	75	65	30	NT, SF
42	66	40	70	33	NT, ST
43	64	21	57	40	NT, ST
44	80	49	22	27	ST, SF

### Chart Interpretation and Conclusion

Occurrences of “ST (*Sensor-Thinker*)” = 25

Occurrences of “SF (*Sensor-Feeler*)” = 14

Occurrences of “NT (*Intuitive-Thinker*)” = 27

Occurrences of “NF (*Intuitive-Feeler*)” = 11

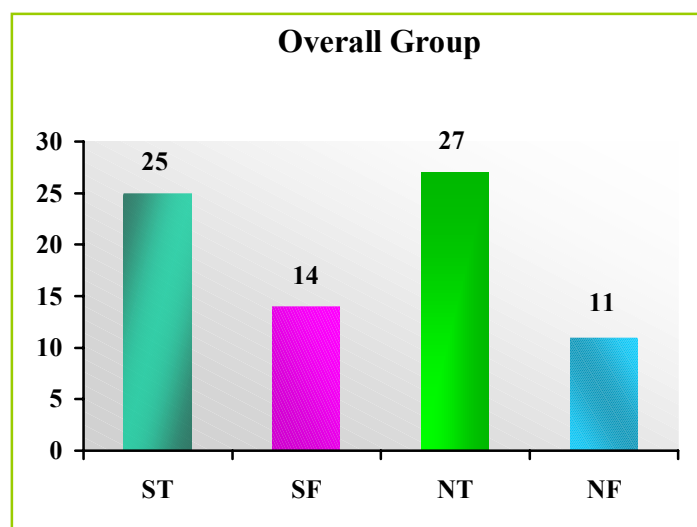

**Graphical Description**

The cognitive profile results of 44 students above shows that ST and NT dominate over SF and NF components. It is, therefore, safe to conclude that a significant majority of the group may fit within the *Sensor-Thinker / Intuitive Thinker* quadrant.



## Appendix F

### STUDENT EVALUATION OF INSTRUCTION (*pilot study*)

### AutoCad A-101 (Group 1, In-Class)

**E=Excellent(5); VG=Very Good(4); G=Good(3);F=Fair(2); P=Poor(1); VP=Very Poor(0)**

	Description	N	E%	VG%	G%	F%	P%	VP%	Median	$\bar{X}$	SD
1	The course as a whole was:	18	22	17	44	17	-	-	4.0	4.444	1.042
2	The course content was:	18	17	11	44	28	-	-	4.0	4.167	1.043
3	The instructor's contribution to the Course was:	18	22	17	28	28	6	-	4.0	4.222	1.263
4	The instructor's effectiveness in teaching the subject matter was:	18	22	28	22	22	6	-	4.5	4.389	1.243
5	Opportunity for practicing what was learned was:	18	22	33	17	17	11	-	5.0	4.389	1.335
6	Sequential development of skills was:	18	11	28	39	11	11	-	4.0	4.167	1.150
7	Explanation of underlying rationales for new techniques or skills were:	18	17	17	33	22	11	-	4.0	4.056	1.259
8	Demonstrations of expected skills were:	18	11	28	39	11	11	-	4.0	4.167	1.150
9	Instructor's confidence in students' ability was:	18	11	17	39	22	11	-	4.0	3.944	1.162
10	Recognition of student progress by instructor was:	18	11	11	39	39	-	-	4.0	3.944	0.998
11	Student confidence in instructor's knowledge was:	18	28	28	33	11	-	-	5.0	4.722	1.018
12	Freedom allowed students to develop own skills and ideas was:	18	11	28	50	11	-	-	4.0	4.389	0.850
13	Instructor's ability to deal with student difficulties was:	18	17	22	39	11	11	-	4.0	4.222	1.215
14	Tailoring of instruction to varying student skills levels was:	18	6	17	50	28	-	-	4.0	4.000	0.840
15	Availability of extra help when needed was:	18	17	17	39	22	6	-	4.0	4.167	1.150
16	Use of class time was:	18	33	11	28	6	11	11	4.0	4.167	1.757
17	Instructor's interest in whether students learned was:	18	22	6	28	33	11	-	4.0	3.944	1.349
18	Amount you learned in the course was:	18	22	11	33	11	17	6	4.0	3.722	1.526
19	Relevance and usefulness of course content were:	18	34	28	22	17	-	-	4.0	4.111	1.367
20	Evaluative and grading techniques (test, projects, etc.) were:	18	28	11	33	22	6	-	3.5	3.444	1.199
21	Reasonableness of assigned work was:	18	11	11	44	17	17	-	4.0	3.833	1.200
22	Clarity of student responsibilities and requirements was:	18	11	11	44	22	11	-	4.0	3.889	1.132
	Grand Mean									4.114	



### STUDENT EVALUATION OF INSTRUCTION AutoCad A-101 (Group 2, In-Class)

**E=Excellent(5); VG=Very Good(4); G=Good(3);F=Fair(2); P=Poor(1); VP=Very Poor(0)**

	<b>Description</b>	<b>N</b>	<b>E%</b>	<b>VG%</b>	<b>G%</b>	<b>F%</b>	<b>P%</b>	<b>VP%</b>	<b>Median</b>	$\bar{X}$	<b>SD</b>
1	The course as a whole was:	14	21	36	29	14	-	-	5.0	4.643	1.008
2	The course content was:	14	7	50	29	14	-	-	5.0	4.500	0.885
3	The instructor's contribution to the Course was:	14	29	21	43	7	-	-	4.5	4.714	0.994
4	The instructor's effectiveness in teaching the subject matter was:	14	29	36	29	7	-	-	5.0	4.857	0.949
5	Opportunity for practicing what was learned was:	14	21	50	21	7	-	-	5.0	4.857	0.864
6	Sequential development of skills was:	14	14	36	36	14	-	-	4.5	4.500	0.941
7	Explanation of underlying rationales for new techniques or skills were:	14	21	29	43	7	-	-	4.0	4.357	1.082
8	Demonstrations of expected skills were:	14	21	29	43	7	-	-	4.5	4.643	0.929
9	Instructor's confidence in students' ability was:	14	29	14	36	21	-	-	4.5	4.500	1.160
10	Recognition of student progress by instructor was:	14	14	50	21	14	-	-	5.0	4.357	1.082
11	Student confidence in instructor's knowledge was:	14	29	43	14	14	-	-	5.0	4.857	1.027
12	Freedom allowed students to develop own skills and ideas was:	14	14	36	14	36	-	-	4.5	4.286	1.139
13	Instructor's ability to deal with student difficulties was:	14	50	29	21	-	-	-	4.5	4.214	0.893
14	Tailoring of instruction to varying student skills levels was:	14	14	36	29	21	-	-	4.5	4.429	1.016
15	Availability of extra help when needed was:	14	14	21	43	14	7	-	4.0	4.214	1.122
16	Use of class time was:	14	29	14	29	7	14	7	4.0	4.143	1.657
17	Instructor's interest in whether students learned was:	14	21	29	36	14	-	-	4.5	4.571	1.016
18	Amount you learned in the course was:	14	14	36	43	7	-	-	4.5	4.500	1.019
19	Relevance and usefulness of course content were:	14	7	29	57	7	-	-	4.0	4.286	0.914
20	Evaluative and grading techniques (test, projects, etc.) were:	14	71	21	7	-	-	-	4.0	4.071	0.730
21	Reasonableness of assigned work was:	14	14	29	50	7	-	-	4.0	4.429	1.016
22	Clarity of student responsibilities and requirements was:	14	14	29	43	7	7	-	4.0	4.357	1.082
	Grand Mean									4.104	



## STUDENT EVALUATION OF INSTRUCTION AutoCad A-102 (Group 1, On-Line Course)

E=Excellent(5); VG=Very Good(4); G=Good(3);F=Fair(2); P=Poor(1); VP=Very Poor(0)

	Description	N	E	VG	G	F	P	VP	Median	$\bar{X}$	SD
1	The course as a whole was:	18	6	17	50	28	-	-	4.0	4.056	0.873
2	The course content was:	18	-	39	33	22	6	-	4.0	4.056	0.938
3	The instructor's contribution to the Course was:	18	6	11	67	17	-	-	4.0	4.056	0.725
4	The instructor's effectiveness in teaching the subject matter was:	18	6	28	33	28	6	-	4.0	4.000	1.029
5	Opportunity for practicing what was learned was:	18	-	28	44	22	6	-	4.0	3.944	0.873
6	Sequential development of skills was:	18	-	22	44	33	-	-	4.0	3.889	0.758
7	Explanation of underlying rationales for new techniques or skills were:	18	-	28	44	28	-	-	4.0	4.000	0.767
8	Demonstrations of expected skills were:	18	22	39	28	11	-	-	4.0	3.722	0.958
9	Instructor's confidence in students' ability was:	18	6	6	44	39	6	-	4.0	3.667	0.907
10	Recognition of student progress by instructor was:	18	-	6	50	33	11	-	4.0	3.500	0.786
11	Student confidence in instructor's knowledge was:	18	-	33	33	28	6	-	4.0	3.944	0.938
12	Freedom allowed students to develop own skills and ideas was:	18	-	33	39	28	-	-	4.0	4.056	0.802
13	Instructor's ability to deal with student difficulties was:	18	-	6	44	28	17	6	3.5	3.278	1.018
14	Tailoring of instruction to varying student skills levels was:	18	-	-	50	28	17	6	3.5	2.222	0.943
15	Availability of extra help when needed was:	18	-	11	33	39	17	-	3.0	3.389	0.916
16	Use of class time was:	18	6	17	56	22	-	-	4.0	4.056	0.802
17	Instructor's interest in whether students learned was:	18	6	6	33	44	6	6	3.0	3.444	1.097
18	Amount you learned in the course was:	18	-	22	39	28	11	-	4.0	3.722	0.958
19	Relevance and usefulness of course content were:	18	-	28	39	28	6	-	4.0	3.889	0.900
20	Evaluative and grading techniques (test, projects, etc.) were:	18	-	-	50	39	6	6	3.5	3.333	0.840
21	Reasonableness of assigned work was:	18	-	6	33	56	-	6	3.0	3.333	0.840
22	Clarity of student responsibilities and requirements was:	18	-	-	44	44	6	6	3.0	3.278	0.826
	Grand Mean									3.674	





## STUDENT EVALUATION OF INSTRUCTION AutoCad A-102 (Group 2, On-line Course)

**E=Excellent(5); VG=Very Good(4); G=Good(3);F=Fair(2); P=Poor(1); VP=Very Poor(0)**

	<b>Description</b>	<b>N</b>	<b>E</b>	<b>VG</b>	<b>G</b>	<b>F</b>	<b>P</b>	<b>VP</b>	<b>Median</b>	$\bar{X}$	<b>SD</b>
1	The course as a whole was:	14	7	21	43	29	-	-	4.000	4.071	0.917
2	The course content was:	14	14	29	36	21	-	-	4.000	4.357	1.008
3	The instructor's contribution to the Course was:	14	7	21	43	29	-	-	4.000	4.071	0.917
4	The instructor's effectiveness in teaching the subject matter was:	14	-	14	71	14	-	-	4.000	4.000	0.555
5	Opportunity for practicing what was learned was:	14	36	7	43	14	-	-	4.000	4.643	1.151
6	Sequential development of skills was:	14	7	14	71	-	7	-	4.000	4.143	0.864
7	Explanation of underlying rationales for new techniques or skills were:	14	-	36	43	7	7	-	4.000	4.143	0.864
8	Demonstrations of expected skills were:	14	7	29	36	29	-	-	4.000	4.143	0.949
9	Instructor's confidence in students' ability was:	14	-	14	71	7	7	-	4.000	3.929	0.730
10	Recognition of student progress by instructor was:	14	-	29	57	14	-	-	4.000	4.143	0.663
11	Student confidence in instructor's knowledge was:	14	21	29	29	21	-	-	4.500	4.500	1.092
12	Freedom allowed students to develop own skills and ideas was:	14	21	29	21	29	-	-	4.500	4.429	1.158
13	Instructor's ability to deal with student difficulties was:	14	21	14	36	21	-	7	4.000	4.143	1.406
14	Tailoring of instruction to varying student skills levels was:	14	-	29	43	14	14	-	4.000	3.857	1.027
15	Availability of extra help when needed was:	14	7	21	36	21	14	-	4.000	3.857	1.167
16	Use of class time was:	14	21	-	64	14	-	-	4.000	4.286	0.994
17	Instructor's interest in whether students learned was:	14	21	21	29	21	7	-	4.000	4.286	1.267
18	Amount you learned in the course was:	14	7	29	43	14	7	-	4.000	4.143	1.027
19	Relevance and usefulness of course content were:	14	29	7	43	7	14	-	4.000	4.286	1.383
20	Evaluative and grading techniques (test, projects, etc.) were:	14	7	14	64	14	-	-	4.000	4.143	0.770
21	Reasonableness of assigned work was:	14	21	21	36	21	-	-	4.000	4.429	1.089
22	Clarity of student responsibilities and requirements was:	14	14	29	36	14	7	-	4.000	4.286	1.139
	<b>Grand Mean</b>									4.194	



## STUDENT EVALUATION OF INSTRUCTION AutoCad A-103 (Group 1, Independent CD-ROM)

**E=Excellent(5); VG=Very Good(4); G=Good(3);F=Fair(2); P=Poor(1); VP=Very Poor(0)**

	Description	N	E	VG	G	F	P	VP	Median	$\bar{X}$	SD
1	The course as a whole was:	18	6	28	39	28	-	-	4.000	4.111	0.900
2	The course content was:	18	11	33	39	17	-	-	4.000	4.389	0.916
3	The instructor's contribution to the Course was:	18	11	22	50	17	-	-	4.000	4.278	0.895
4	The instructor's effectiveness in teaching the subject matter was:	18	17	22	28	33	-	-	4.000	4.222	1.114
5	Opportunity for practicing what was learned was:	18	11	22	44	17	6	-	4.000	4.167	1.043
6	Sequential development of skills was:	18	-	33	39	28	-	-	4.000	4.056	0.802
7	Explanation of underlying rationales for new techniques or skills were:	18	11	22	39	28	-	-	4.000	4.167	0.985
8	Demonstrations of expected skills were:	18	22	11	33	33	-	-	4.000	4.222	1.166
9	Instructor's confidence in students' ability was:	18	11	28	39	22	-	-	4.000	4.278	0.958
10	Recognition of student progress by instructor was:	18	6	11	39	33	11	-	4.000	3.667	1.029
11	Student confidence in instructor's knowledge was:	18	28	-	28	28	17	-	4.000	3.944	1.474
12	Freedom allowed students to develop own skills and ideas was:	18	6	22	33	33	6	-	4.000	3.889	1.023
13	Instructor's ability to deal with student difficulties was:	18	17	11	39	11	22	-	4.000	3.889	1.367
14	Tailoring of instruction to varying student skills levels was:	18	6	33	17	39	6	-	4.000	3.944	1.110
15	Availability of extra help when needed was:	18	17	11	33	11	28	-	4.000	3.778	1.437
16	Use of class time was:	18	6	17	50	22	6	-	4.000	3.944	0.938
17	Instructor's interest in whether students learned was:	18	6	22	33	28	11	-	4.000	3.833	1.098
18	Amount you learned in the course was:	18	6	28	33	28	6	-	4.000	4.000	1.029
19	Relevance and usefulness of course content were:	18	6	22	44	28	-	-	4.000	4.056	0.873
20	Evaluative and grading techniques (test, projects, etc.) were:	18	11	17	44	17	11	-	4.000	4.000	1.138
21	Reasonableness of assigned work was:	18	6	22	44	17	11	-	4.000	3.944	1.056
22	Clarity of student responsibilities and requirements was:	18	11	28	28	22	11	-	4.000	4.056	1.211
	Grand Mean									4.037	



### STUDENT EVALUATION OF INSTRUCTION AutoCad A-103 (Group 2, Independent CD-ROM)

**E=Excellent(5); VG=Very Good(4); G=Good(3);F=Fair(2); P=Poor(1); VP=Very Poor(0)**

	<b>Description</b>	<b>N</b>	<b>E</b>	<b>VG</b>	<b>G</b>	<b>F</b>	<b>P</b>	<b>VP</b>	<b>Median</b>	$\bar{X}$	<b>SD</b>
1	The course as a whole was:	14	7	29	50	14	-	-	4.000	4.286	0.825
2	The course content was:	14	14	36	43	7	-	-	4.500	4.571	0.852
3	The instructor's contribution to the Course was:	14	21	21	29	29	-	-	4.000	4.357	1.151
4	The instructor's effectiveness in teaching the subject matter was:	14	21	29	36	14	-	-	4.500	4.571	1.016
5	Opportunity for practicing what was learned was:	14	36	21	29	7	7	-	5.000	4.714	1.267
6	Sequential development of skills was:	14	7	29	50	7	7	-	4.000	4.214	0.975
7	Explanation of underlying rationales for new techniques or skills were:	14	21	21	21	29	7	-	4.000	4.214	1.311
8	Demonstrations of expected skills were:	14	7	29	29	29	7	-	4.000	4.000	1.109
9	Instructor's confidence in students' ability was:	14	14	21	36	21	7	-	4.000	4.143	1.167
10	Recognition of student progress by instructor was:	14	7	29	36	21	7	-	4.000	4.071	1.072
11	Student confidence in instructor's knowledge was:	14	21	7	57	14	-	-	4.000	4.357	1.008
12	Freedom allowed students to develop own skills and ideas was:	14	14	21	43	21	-	-	4.000	4.286	0.994
13	Instructor's ability to deal with student difficulties was:	14	7	21	43	14	14	-	4.000	3.929	1.141
14	Tailoring of instruction to varying student skills levels was:	14	7	29	21	29	14	-	4.000	3.857	1.231
15	Availability of extra help when needed was:	14	14	7	43	21	14	-	4.000	3.857	1.231
16	Use of class time was:	14	29	7	29	21	14	-	4.000	4.143	1.460
17	Instructor's interest in whether students learned was:	14	14	36	29	21	-	-	4.500	4.429	1.016
18	Amount you learned in the course was:	14	14	29	36	14	-	7	4.000	4.214	1.311
19	Relevance and usefulness of course content were:	14	36	50	7	7	-	-	4.000	4.071	1.072
20	Evaluative and grading techniques (test, projects, etc.) were:	14	7	29	43	14	-	7	4.000	4.071	1.207
21	Reasonableness of assigned work was:	14	14	21	50	7	-	7	4.000	4.214	1.251
22	Clarity of student responsibilities and requirements was:	14	7	36	43	7	-	7	4.000	4.214	1.188
	Grand mean									4.217	

## Summary

Group Name	Instructional Method	Grand Mean
Group 1	A101- In-Class	4.114
Group 1	A102 - Online Course	3.674
Group 1	A103- Independent CD-ROM	4.037
Group 2	A101 - In-Class	4.104
Group 2	A102 - Online Course	4.194
Group 2	A103 - Independent CD-ROM	4.217

Group One Represents a *daytime* adult Continuing Education students at Kean University. This group consists mostly of unemployed personnel from a variety of professional and ethnic backgrounds.

Group Two Represents an *evening* adult Continuing Education students at Kean University. This group consists mostly of working personnel from a variety of professional and ethnic backgrounds.



## Appendix G

**Academic Achievement Results (Pilot Study)****Actual Grades Table**

<i>Test</i>	<i>Group No.</i>	<i>N</i>	<i>Actual Test Grade List</i>
<b>A101</b>	<b>I</b>	18	52,72,68,72,80,68,68,84,56,84,56,88,92,84,80,88,64,64
<b>A102</b>	<b>I</b>	18	52,92,92,96,96,88,72,92,92,96,88,88,76,68,48,76,56,44
<b>A103</b>	<b>I</b>	18	80,84,82,82,48,68,64,64,52,68,84,36,88,60,64,68,72,76
<b>A101</b>	<b>II</b>	14	60,80,64,64,76,68,84,80,88,68,72,60,48,68
<b>A102</b>	<b>II</b>	14	60,64,68,88,80,88,76,72,92,76,84,60,92,72
<b>A103</b>	<b>II</b>	14	52,52,76,40,52,44,60,40,48,64,72,56,48,64

**A101 (Group I): Number of items = 18**

Mean = 73.333

95% confidence interval for Mean: 66.31 thru 80.36

Standard Deviation = 12.195

High = 92.0 Low = 52.0

Median = 72.000

Average Absolute Deviation from Median = 10.2

**A102 (Group I): Number of items = 18**

Mean = 78.444

95% confidence interval for Mean: 71.42 thru 85.47

Standard Deviation = 17.843

High = 96.0 Low = 44.0

Median = 88.000

Average Absolute Deviation from Median = 14.0

**A103 (Group I): Number of items = 18**

Mean = 68.889

95% confidence interval for Mean: 61.86 thru 75.92

Standard Deviation = 13.945

High = 88.0 Low = 36.0

Median = 68.000

Average Absolute Deviation from Median = 10.7

**A101 (Group II): Number of items = 14**

Mean = 70.000

95% confidence interval for Mean: 64.02 thru 75.98

Standard Deviation = 10.842

High = 88.0 Low = 48.0

Median = 68.000

Average Absolute Deviation from Median = 8.29

**A102 (Group II): Number of items = 14**

Mean = 76.571

95% confidence interval for Mean: 70.59 thru 82.55

Standard Deviation = 11.189

High = 92.0 Low = 60.0

Median = 76.000

Average Absolute Deviation from Median = 9.14

**A103 (Group II): Number of items = 14**

Mean = 54.857

95% confidence interval for Mean: 48.88 thru 60.84

Standard Deviation = 11.141

High = 76.0 Low = 40.0

Median = 52.000

Average Absolute Deviation from Median = 8.57

**Achievement Statistics Table**

<i>Test</i>	<i>Group No.</i>	<i>N</i>	<i>Mean</i>	<i>Standard Deviation</i>	<i>Standard Error of the Mean</i>	<i>Median</i>
<b>A101</b>	<b>I</b>	18	73.333	12.195	2.874	72.000
<b>A102</b>	<b>I</b>	18	78.444	17.843	4.206	88.000
<b>A103</b>	<b>I</b>	18	68.889	13.945	3.287	68.000
<b>A101</b>	<b>II</b>	14	70.000	10.842	2.898	68.000
<b>A102</b>	<b>II</b>	14	76.571	11.189	2.990	76.000
<b>A103</b>	<b>II</b>	14	54.857	11.141	2.978	52.000

## ANOVA

### Achievement Statistics results

---

#### Analysis of Variance for Group I

	<b>Sum of Squares</b>	<b>DF</b>	<b>Mean Square (Variance)</b>	<b>F</b>	<b>Significance (<i>p</i> value)</b>
Between Groups	823.02	2	411.508	1.866	0.165 <sup>1</sup>
Within Groups	11246.41	51	220.517		
Total	12069.43	53			

#### Post-hoc t-test (Group I)

<b>Group</b>	<b>Group</b>	<b>t-value</b>	<b>DF</b>	<b>Probability</b>
A101	A102	-1.033	34	0.3091
A101	A103	0.898	34	0.3756
A102	A103	1.930	34	0.0619

---

<sup>1</sup> P-value is greater than alpha value (.05): No significant difference exist between the three methods of instruction

### Analysis of Variance for Group II

	Sum of Squares	DF	Mean Square (Variance)	F	Significance ( <i>p</i> value)
Between Groups	3471.94	2	1735.968	14.196	0.000 <sup>2</sup>
Within Groups	4769.24	39	122.288		
Total	8241.18	41			

### Post-hoc t-test (Group II)

Group	Group	t-value	DF	Probability
A101	A102	-1.572	26	0.1280
A101	A103	3.623	26	0.0012*
A102	A103	5.195	26	0.0000*

---

<sup>2</sup> P-value is less than alpha value (.05): Significant difference does exist between the three methods of instruction



## Appendix H

### **Pilot Study: An Experimental Analysis of a Parametric, Non-Linear, Hyperlearning Model.**

By

1. **James A. Sinclair, Ed.S.**  
Department of Technology  
Kean University, Union, New Jersey  
Phone: (908) 737-3517  
Fax: (908) 737-3515  
E-mail: ittc@comcast.net
  
2. **Kamal Shahrabi, Ph.D.**  
Department of Technology  
Kean University, Union, New Jersey  
Phone: (908) 737-3517  
Fax: (908) 737-3505  
E-mail: shahrabi@kean.edu
  
3. **Mark Rossi, BS Eng. Sci., BS Comp. Sci.**  
Department of Technology  
Kean University, Union, New Jersey  
Phone: (908) 737-3517  
Fax: (908) 737-3515  
E-mail: mrossi2001@si.rr.com

## **Pilot Study: A Quasi-Experimental Analysis of a Parametric, Non-Linear, Hyperlearning Model.**

### **Introduction**

This paper had distilled from a much larger experimental study conducted at one of New Jersey's largest State Universities in 2002-2003. One major aspect of this exploratory quasi-experimental study, was to develop, document, and explore the outcome of an adult continuing education CAD course that was conducted by employing the Hyperlearning educational model. As opposed to the original five-segment Hyperlearning model, developed by Lewis Perelman in the early nineties, a modified and appropriate model was chosen. It is comprised of three components: a traditional in-class segment; a professor-facilitated synchronous on-line component; and an independent, asynchronous self-learning segment (using a CD-ROM based tutorial).

The study focused on the effectiveness of adult Continuing Education (CE) students, pursuing careers and certifications in Technology and/or Computer Aided Design, to adapt to the proposed, non-linear educational model, which involves a combination of traditional, as well as Human-Computer interactive philosophies.

### **The CAD Paradigm**

Within approximately the past ten years, Computer Aided Design (CAD), representing a seemingly small aspect of modern technology, has been heavily integrated into a variety of disciplines. Examples abound in technical professions such as Architecture, Web Development, Interior Design, Landscaping, Drafting, Civil Design, Law (accident reconstruction, forensic analysis, etc.), Medicine, and all branches of Engineering (Burlison, W., Ganz, A., & Harris, I., 2001).

Due to the increasing popularity of computers in the modern workplace, a variety of new professions have developed in areas that in the past had been strictly the domain of manual labor and skilled craftsmanship. One such area of technology will be discussed in this study: that of Computer Aided Design (CAD), which distilled from manual architectural / mechanical drafting, both of which were used to graphically represent engineering thoughts and ideas.

The increasing affordability of computers has resulted in the growth of manufacturing and design companies that are interested in implementing CAD technology. Computer Aided Design has arisen as a distinct field of technology; a field that has become a unifying factor in integrating the disciplines of computer graphics, human factors, industrial and applied engineering, computer science, and robotics (Torre, 2000; Ilabaca, 2000).

### **Computer-Based Learning**

The growth of online and computer-based training programs has been significant in recent years, and the future growth potential within higher and continuing education remains virtually limitless in terms of the opportunities for both the institutions and the learners. However, the capabilities and efficacy of such programs have yet to be fully

investigated. An extensive amount of effort in this area has been mostly devoted to program development and most systematic examinations of program quality and effectiveness. With little empirical knowledge about computer-based education outcomes and processes, the need for research in this area is not only timely, but also imperative.

### **Hyper-learning Educational Model**

The original Hyper-learning model, proposed by Lewis Perelman in 1992, suggested five learning modules:

1. Lecture (traditional in-class method)
2. Tutorial teaching (instructor facilitated, online-based)
3. Tutorial teaching (self directed, video, CD-ROM, etc.)
4. Group recollection (applying a portion of information in small groups)
5. Student teach-back (students teach portion of learned material to the rest of the class)

Although all five modules have a measure of effectiveness, for the purpose of this study, only the first three modules were selected. One of the reasons Computer Aided Design (CAD) was chosen for this study is its unifying factor, and because this skill transcends all branches of modern engineering and technology (e.g. mechanical, electrical, nuclear, medical, etc.). Thus, the results of this study may affect a large majority of technical students.

### **Purpose**

The purpose of the proposed study was to measure the academic achievement, as well as objective course satisfaction differences of groups of adult students, according to their individual ability levels, when taught by three methods of instruction. In order to accomplish this, basic traditional instruction will be supplemented by an instructor facilitated online component in the second segment of the analysis, and completely replaced in the third, by a “step-by-step” CAD tutorial program on CD-ROM (i.e. the ability to communicate with the instructor is replaced by a completely independent study method).

In summation, the problem that was investigated is whether the Hyperlearning instruction method in CAD, is in fact, an effective alternative to the traditional classroom methodology. The proposed study will examine the adaptability of the group (adult Continuing Education CAD students) to the proposed non-linear educational model, involving a combination of traditional, as well as Human-Computer Interactive philosophies.

### **Theoretical Framework**

The major theoretical framework of the study was based upon the existing body of evidence encompassing the following aspects:

1. Body of research that examined educational styles and cognitive profiles of adult learners, entering technology careers (Briggs & Meyers, 1991; Jung, 1990; Hess, Zachar & Kramer, 2001).

2. Body of evidence related to computer-based and Web-based instruction in technology, architecture, engineering, and graphics design (Burlison, Ganz, & Harris, 2001; Florman, 1997; Torre, 2000).
3. Research related to Hyper-learning and other existing educational models that involve a combination of traditional and computer-based learning methods (Perelman, 1992; Winkleman, 1999).
4. Comprehensive analysis of possible “gaps” in the above-mentioned body of research, as well as further study recommendations, to analyze the applicability of existing work to the specific student group and the subject of Computer-Aided Design.

Long before the advent of the World Wide Web as a medium, distance learning was seen as one solution to equal access, as well as cost and time effective use of learning resources (Ilabaca, 2000). The objective of any effort to improve distance learning is to make the experience of the distance learner as complete as that of the traditionally educated student (Simonson, Smaldino, Albright, and Zvacek, 2002).

Over the years, many scholarly experts have proposed ways of improving the educational system, both at the pre-college and college level. Most improvements have centered on increasing productivity, although recently, cost control and quality have become motivating factors (Ertmer & Newby, 1996; Perelman, 1992; Simonson, Smaldino, Albright, and Zvacek, 2002). The original author of Hyperlearning (Perelman, 1992) proposes this model as the centerpiece of a multimedia and communication based education network that will provide education to all students, whether traditional or nontraditional, in just the correct quantity, at the correct time. He feels that the present system places schooling and learning at odds, with the present schooling system being justified by tradition alone and propped up by a system of myths that can be summed up with the saying: “People learn best in School” (Perelman, 1992; Pistillo, 1996).

## **Methodology**

The participating students were required to complete a 40 Hr. (10 week) CAD course presented in the following manner:

- a. 30% (12 Hrs./3 sessions) of the prescribed course content, using linear methodology (traditional classroom training, with the professor presenting the prescribed material and being available to help students in person). At the end of the segment, students were required to complete an anonymous Student Satisfaction Inventory (IAS-Form E) (OES-UW, 2002), as well as complete the Autocad Achievement Examination (Section Module Test-A101) (Kalameja, 2000). This test covered only the scope of material presented during the first, three-week training segment.
- b. 30% (12 Hrs./3 sessions) of the material was facilitated by the professor via a synchronous Internet-based course. At this stage, the students were required to communicate with the instructor on a daily basis and at scheduled times, so as to receive new information and complete the required material. The

communication was conducted via an established, live, Internet-based communication forum, specifically dedicated to the study. At the end of the segment, students were required to complete an anonymous Student Satisfaction Inventory, as well as to complete the Autocad Achievement Examination (Section Module Test-A102). This test covered only the scope of material presented during the second training segment (i.e. Web-based).

- c. 30% (12 Hrs./3 sessions.) of the curriculum material was presented via an independent study, using a well-recognized Autodesk-certified instructional CD-ROM tutorial. As in the preceding stage, the students completed the prescribed curriculum material independently, but were still able to communicate with the professor in an asynchronous manner (i.e. via the e-mail, postal service, etc.) At the end of the segment, students were required to complete an anonymous Student Satisfaction Inventory, as well as complete the Autocad Achievement Examination (Section Module Test-A103). This test covered only the scope of material learned during the third, three-week training segment (i.e. CD-ROM based).
- d. The remaining 10% of the time (4 Hrs./one session) was dedicated to a summary of the course, as well as participation in personal interview with the professor.

**Analysis**

All statistical tests in the proposed project were conducted with a significance level of  $\alpha = 0.05$  to assure 95% accuracy.

Data was recorded for each student, for each question. As shown in the figure below, a standard report form available at IAS-UW will contain a number of respondents, percentages of answers for each of the 22 questions, actual mean, median, and standard deviation<sup>1</sup> (see figure below).

<b>I nstru ctional A ssess ment S ystem</b>	CS 101 AA								
	Introduction to Computing								
	North campus				Jane Doe				
	Sample Online College				Fall 1999				
<b>ONLINE STUDENT EVALUATION OF INSTRUCTION</b>									
<b>E=Excellent; VG=Very Good; G=Good; F=Fair; P=Poor; VP=Very Poor</b>									
		<b>PERCENTAGES<sup>1</sup></b>					<b>MEAN</b>	<b>MEDIAN</b>	
	<b>No. Resp's</b>	<b>E (5)</b>	<b>VG (4)</b>	<b>G (3)</b>	<b>F (2)</b>	<b>P (1)</b>	<b>VP (0)</b>		
The course as a whole was:	22	36	45	14	5			4.14 4.20	
The course content was:	21	24	43	29	5			3.86 3.89	
The instructor's contribution to student learning was:	22	55	27	14	5			4.32 4.58	
The effectiveness of the delivery format was:	22	32	45	14	9			4.00 4.10	
Relevance of required readings (Web sites, articles, texts, etc.) was:	19	32	42	16	5	5		3.89 4.06	

<sup>1</sup> Standard Deviation is not shown on the actual report, but was later added by the researcher.

In summary, there were three final forms presented in the study for the student satisfaction category. Each form represented the results of each of the three stages of the experiment. Then, these results were statistically analyzed, using Fisher's *F-test* one-way analysis of variance (ANOVA) statistical method, comparing percentage means and standard deviations of the objective student satisfaction between the three methods of instruction (in-class, instructor facilitated online course, and independent CD-ROM based course).

### Academic Achievement

The academic achievement results were recorded and reported in the following manner:

1. Grades were collected from the three AutoCAD achievement modules (A101, 102, and 103).
2. The data was reported in two separate tables, one listing the actual grades of individual students in the group against the corresponding test module, and another, listing the following: test number, number of students, mean of the group, standard deviation, standard error of the mean, and the median.
3. Analysis of Variance (ANOVA) statistical comparison was conducted between the achievement results from the three learning methods.
4. The final ANOVA report provided the sum of squares data between the groups (i.e. methods of instruction), within groups, and total; degrees of freedom; mean square (variance); F- number (Fisher's coefficient); and a significance (p) value.

In addition, since a significant difference in academic achievement existed between the three instructional methods within Group II ( $p < .05$ ), a post-hoc analysis was performed to establish the actual relationship, as well as to indicate where the differences had actually occurred.

### Findings

Two separate groups were involved in the experimentation. Both groups received identical treatment. Due to the relatively small group sizes, to obtain a more precise statistical analysis, it was best to perform the experiment using multiple groups. Although an array of groups of students will be involved in the long-term experimentation, shown below are the results of only two such groups (depicted here as Group I and II, 18 and 14 participants, respectively). Although the treatment for both groups was identical, one important factor should be noted here – the groups consisted of slightly different representative populations. The first group (N=18), consisted of mostly professional and currently working students, possessing degrees or at least some college educational background. The second group (N=14), consisted of unemployed manufacturing personnel, possessing only High School-level education. Since this research was conducted by the Department of Continuing Education, it was important to see if significant differences existed in the learning patterns of both groups under investigation.

**Achievement Statistics Table (both groups)**

<i>Test</i>	<i>Group No.</i>	<i>N</i>	<i>Mean</i>	<i>Standard Deviation</i>	<i>Standard Error of the Mean</i>	<i>Median</i>
<b>A101</b>	<b>I</b>	18	73.333	12.195	2.874	72.000
<b>A102</b>	<b>I</b>	18	78.444	17.843	4.206	88.000
<b>A103</b>	<b>I</b>	18	68.889	13.945	3.287	68.000
<b>A101</b>	<b>II</b>	14	70.000	10.842	2.898	68.000
<b>A102</b>	<b>II</b>	14	76.571	11.189	2.990	76.000
<b>A103</b>	<b>II</b>	14	54.857	11.141	2.978	52.000

**Analysis of Variance (ANOVA) for Group I**

	<b>Sum of Squares</b>	<b>DF</b>	<b>Mean Square (Variance)</b>	<b>F</b>	<b>Significance (p value)</b>
Between Groups	823.02	2	411.508	1.866	0.165 <sup>2</sup>
Within Groups	11246.41	51	220.517		
Total	12069.43	53			

**Post-hoc t-test (Group I)**

<b>Group</b>	<b>Group</b>	<b>t-value</b>	<b>DF</b>	<b>Probability</b>
A101	A102	-1.033	34	0.3091
A101	A103	0.898	34	0.3756
A102	A103	1.930	34	0.0619

**Analysis of Variance (ANOVA) for Group II**

<sup>2</sup> P-value is greater than alpha value (.05): No significant difference exist between the three methods of instruction

	<b>Sum of Squares</b>	<b>DF</b>	<b>Mean Square (Variance)</b>	<b>F</b>	<b>Significance (p value)</b>
Between Groups	3471.94	2	1735.968	14.196	0.000 <sup>3</sup>
Within Groups	4769.24	39	122.288		
Total	8241.18	41			

### Post-hoc t-test (Group II)

<b>Group</b>	<b>Group</b>	<b>t-value</b>	<b>DF</b>	<b>Probability</b>
A101	A102	-1.572	26	0.1280
A101	A103	3.623	26	0.0012*
A102	A103	5.195	26	0.0000*

As indicated by the statistical analysis shown above, the two groups had shown slightly different achievement results. The first group had shown that no significant difference exists within the three instructional methods. The results for the second group indicated that there was significant difference between the first and the third method, as well as between the second and the third method. The Student Satisfaction Inventory results indicated no significant differences between the methods of instruction. In case of both groups, the null hypotheses were not rejected

### Implications

Is it clear that alternative methods of educational delivery are equally effective in all areas of technology? Probably not. A very enthusiastic classroom professor would probably be a much more effective educator than a poorly developed distance learning or CD-ROM based course. However, as the above experiment, together with a myriad of other on-going research, shows a real potential for alternate and eventually improved educational methodologies. Distance learning is becoming, a completely accepted route of learning. This is true not only for Continuing Education and professional training, but also for accredited University curricula, worldwide.

<sup>3</sup> P-value is less than alpha value (.05): Significant difference does exist between the three methods of instruction



**References Cited** (for the above publication only)

- Briggs, K., & Myers, I. (1991). *Myers-Briggs Type Indicator*. Palo Alto, CA: Consulting Psychologists Press.
- Burleson, W., Ganz, A., & Harris, I. (2001). Educational Innovations in Multimedia Systems. *Journal of Engineering Education*, 90 (1), 21-31.
- Ertmer, P.A., & Newby, T. (1996). The Expert Learner: Strategic, Self-Regulated and Reflective. *Instructional Science*, 24, 1-24.
- Florman, S. (1997). Escape From Engineering Boot Camp. *Technology Review*, 96 (1).
- Hess, A., Zachar, P., & Kramer, J. (2001). *The fourteenth mental measurements yearbook* [Electronic version]. Retrieved January 10, 2003, from the Buros Institute: <http://www.unl.edu/buros>
- Ilabaca, J.S. (2000). To Learn with the Internet: Myths and Realities. *Proceedings 4<sup>th</sup> Iberoamerican Congress on Informatics and Education, RIBIE 2000*, Viña del Mar, Chile Santiago, Chile: University of Chile Press.
- Jung, C.G. (1990). *Psychological Types*, ninth printing, revision by Hull, R.F.C. of the translation by Baynes, H.G. Princeton, NJ: Princeton Press.
- Kalameja, A. (2000). *AutoCAD 2000: Assessment Exam Preparation Manual*. Albany, NY: Autodesk Press.
- OES-UW (2002). *Educational Assessment Form E*. Office of Educational Assessment. Seattle, WA: University of Washington.
- Perelman, L. (1992). *School's Out: Hyperlearning, the New Technology*. New York, NY: William Morrow & Co. Publications.
- Pistillo, D. (1996). Hyperlearning: A Hybrid Model for Higher Education. White paper. Tempe, AZ: *University of Advanced Computer Technology (UACT)*.
- Simonson, M., Smaldino, S., Albright, & Zvacek, S. (2002). *Teaching and Learning at a Distance: Foundations of Distance Education*. Upper Saddle River, NJ: Prentice Hall Publications.
- Torre, M. (2000). *Celebrating Computers in Engineering*. New York, NY: American Society of Mechanical Engineers.
- Winkleman, M. (1999). The Applications of Hyper-learning in the Classroom. Santa Clara, CA: *Conference presentation at Syllabus '99*.

## Appendix I Cognitive Profile Inventory

*Sample Instructions before starting the Cognitive Profile Inventory procedure:*



### Determining your Cognitive Profile

The Cognitive Profile Inventory is designed to help you to identify your personal style of thinking, learning, and making decisions. Although an individual's profile is subject to some change over time due to lifestyle, education, and other significant influences, the general shape of the profile probably won't change a great deal. But before too many details are discussed, the first step is to do the inventory for yourself. Once you have your own profile in front of you, the description of what it means will be much more meaningful.

The inventory consists of 60 pairs of words. You are to look at each pair, and choose which appeals to you more, or describes you better. As you are doing the inventory, keep in mind how you prefer to deal with life, learning, and people. It is important that your answers reflect how you really prefer to do things, not what you think you *should* do, or what someone tells you that you should do, or how someone else does things, no

matter how much you admire them. No answer is better than any other answer. The best answer is the one that is right for you. This is your inventory, and it will be your profile. The more thoughtful and honest you are in self-evaluation, the more helpful the resulting profile will be for you.

For each pair of words, **choose one**, and then select one of the values between <one> and <<<<four>>>>. If you have a strong preference, you would assign it a higher value. You might think in terms of the following guidelines for values:

<	>	<b>I generally prefer this some of the time, probably a little more often than the other choice.</b>
<<	>>	<b>I definitely prefer this over the other choice most of the time.</b>

««	»»	<b>I strongly prefer this one, would very rarely choose the other</b>
«««	»»»	<b>Absolutely! Would probably never (or almost never) choose the other if this choice were available.</b>

For example, in flavors of ice cream:

Vanilla	Chocolate
«««   ««   «   <	>   »   »»   «««

I personally would choose chocolate and give it 4 points, since I would almost always choose chocolate if my choice were between vanilla and chocolate.

If I liked vanilla a bit more than chocolate, my choice might look like this:

Vanilla	Chocolate
«««   ««   «   ◼ <	>   »   »»   «««

After you've completed all the pairs, a graph like the one below will illustrate the inventory score. Please print the graph page and refer to the book to continue.

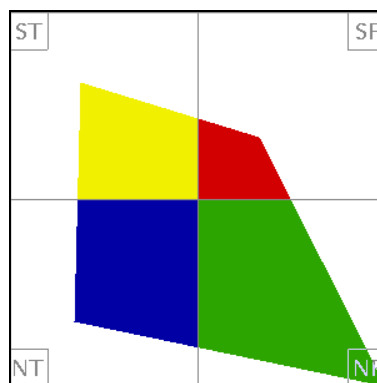

## Cognitive Profile Inventory

Clemson University  
By Dr. Lois B. Krause  
2000

Practical	4	3	2	1	1	2	3	4	
Facts	4	3	2	1	1	2	3	4	Emotional
Doing	4	3	2	1	1	2	3	4	Feelings
Concrete	4	3	2	1	1	2	3	4	Talking
Read a book	4	3	2	1	1	2	3	4	Personal
Get it done	4	3	2	1	1	2	3	4	Tell a story
Roles	4	3	2	1	1	2	3	4	Enjoy doing
Sensible	4	3	2	1	1	2	3	4	Loyalties
Protect yourself	4	3	2	1	1	2	3	4	Emotional
Practice	4	3	2	1	1	2	3	4	For the children
Subtotals: "A"=									Discuss
									= "B"

	4	3	2	1	1	2	3	4	
Trial & error	4	3	2	1	1	2	3	4	Strategy
Protect yourself	4	3	2	1	1	2	3	4	Tell the truth
Specifics	4	3	2	1	1	2	3	4	Overview
Concrete	4	3	2	1	1	2	3	4	Abstract
Read a book	4	3	2	1	1	2	3	4	Work a puzzle
Get it done	4	3	2	1	1	2	3	4	Plan it out
Roles	4	3	2	1	1	2	3	4	Laws
Sensible	4	3	2	1	1	2	3	4	Logical
Information	4	3	2	1	1	2	3	4	Concepts
Practice	4	3	2	1	1	2	3	4	Understand
Subtotals: "A"=									= "C"





# Appendix J

## Instructional Assessment System Forms

### Instructional Assessment System

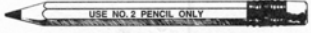

USE NO. 2 PENCIL ONLY

FORM  
**A**

**Fill in bubbles darkly and completely.  
Erase errors cleanly.**

Instructor \_\_\_\_\_ Course \_\_\_\_\_ Section \_\_\_\_\_ Date \_\_\_\_\_

**Completion of this questionnaire is voluntary. You are free to leave some or all questions unanswered.**

		Excel- lent	Very Good	Good	Fair	Poor	Very Poor	
1. The course as a whole was:	<input type="radio"/>	<input type="radio"/>	<input type="radio"/>	<input type="radio"/>	<input type="radio"/>	<input type="radio"/>	<input type="radio"/>	
2. The course content was:	<input type="radio"/>	<input type="radio"/>	<input type="radio"/>	<input type="radio"/>	<input type="radio"/>	<input type="radio"/>	<input type="radio"/>	
3. The instructor's contribution to the course was:	<input type="radio"/>	<input type="radio"/>	<input type="radio"/>	<input type="radio"/>	<input type="radio"/>	<input type="radio"/>	<input type="radio"/>	
4. The instructor's effectiveness in teaching the subject matter was:	<input type="radio"/>	<input type="radio"/>	<input type="radio"/>	<input type="radio"/>	<input type="radio"/>	<input type="radio"/>	<input type="radio"/>	
5. Course organization was:	<input type="radio"/>	<input type="radio"/>	<input type="radio"/>	<input type="radio"/>	<input type="radio"/>	<input type="radio"/>	<input type="radio"/>	
6. Clarity of instructor's voice was:	<input type="radio"/>	<input type="radio"/>	<input type="radio"/>	<input type="radio"/>	<input type="radio"/>	<input type="radio"/>	<input type="radio"/>	
7. Explanations by instructor were:	<input type="radio"/>	<input type="radio"/>	<input type="radio"/>	<input type="radio"/>	<input type="radio"/>	<input type="radio"/>	<input type="radio"/>	
8. Instructor's ability to present alternative explanations when needed was:	<input type="radio"/>	<input type="radio"/>	<input type="radio"/>	<input type="radio"/>	<input type="radio"/>	<input type="radio"/>	<input type="radio"/>	
9. Instructor's use of examples and illustrations was:	<input type="radio"/>	<input type="radio"/>	<input type="radio"/>	<input type="radio"/>	<input type="radio"/>	<input type="radio"/>	<input type="radio"/>	
10. Quality of questions or problems raised by instructor was:	<input type="radio"/>	<input type="radio"/>	<input type="radio"/>	<input type="radio"/>	<input type="radio"/>	<input type="radio"/>	<input type="radio"/>	
11. Student confidence in instructor's knowledge was:	<input type="radio"/>	<input type="radio"/>	<input type="radio"/>	<input type="radio"/>	<input type="radio"/>	<input type="radio"/>	<input type="radio"/>	
12. Instructor's enthusiasm was:	<input type="radio"/>	<input type="radio"/>	<input type="radio"/>	<input type="radio"/>	<input type="radio"/>	<input type="radio"/>	<input type="radio"/>	
13. Encouragement given students to express themselves was:	<input type="radio"/>	<input type="radio"/>	<input type="radio"/>	<input type="radio"/>	<input type="radio"/>	<input type="radio"/>	<input type="radio"/>	
14. Answers to student questions were:	<input type="radio"/>	<input type="radio"/>	<input type="radio"/>	<input type="radio"/>	<input type="radio"/>	<input type="radio"/>	<input type="radio"/>	
15. Availability of extra help when needed was:	<input type="radio"/>	<input type="radio"/>	<input type="radio"/>	<input type="radio"/>	<input type="radio"/>	<input type="radio"/>	<input type="radio"/>	
16. Use of class time was:	<input type="radio"/>	<input type="radio"/>	<input type="radio"/>	<input type="radio"/>	<input type="radio"/>	<input type="radio"/>	<input type="radio"/>	
17. Instructor's interest in whether students learned was:	<input type="radio"/>	<input type="radio"/>	<input type="radio"/>	<input type="radio"/>	<input type="radio"/>	<input type="radio"/>	<input type="radio"/>	
18. Amount you learned in the course was:	<input type="radio"/>	<input type="radio"/>	<input type="radio"/>	<input type="radio"/>	<input type="radio"/>	<input type="radio"/>	<input type="radio"/>	
19. Relevance and usefulness of course content were:	<input type="radio"/>	<input type="radio"/>	<input type="radio"/>	<input type="radio"/>	<input type="radio"/>	<input type="radio"/>	<input type="radio"/>	
20. Evaluative and grading techniques (tests, papers, projects, etc.) were:	<input type="radio"/>	<input type="radio"/>	<input type="radio"/>	<input type="radio"/>	<input type="radio"/>	<input type="radio"/>	<input type="radio"/>	
21. Reasonableness of assigned work was:	<input type="radio"/>	<input type="radio"/>	<input type="radio"/>	<input type="radio"/>	<input type="radio"/>	<input type="radio"/>	<input type="radio"/>	
22. Clarity of student responsibilities and requirements was:	<input type="radio"/>	<input type="radio"/>	<input type="radio"/>	<input type="radio"/>	<input type="radio"/>	<input type="radio"/>	<input type="radio"/>	
<b>Relative to other college courses you have taken:</b>								
23. Do you expect your grade in this course to be:		Much Higher		Average		Much Lower		
24. The intellectual challenge presented was:	<input type="radio"/>	<input type="radio"/>	<input type="radio"/>	<input type="radio"/>	<input type="radio"/>	<input type="radio"/>	<input type="radio"/>	
25. The amount of effort you put into this course was:	<input type="radio"/>	<input type="radio"/>	<input type="radio"/>	<input type="radio"/>	<input type="radio"/>	<input type="radio"/>	<input type="radio"/>	
26. The amount of effort to succeed in this course was:	<input type="radio"/>	<input type="radio"/>	<input type="radio"/>	<input type="radio"/>	<input type="radio"/>	<input type="radio"/>	<input type="radio"/>	
27. Your involvement in this course (doing assignments, attending classes, etc.) was:	<input type="radio"/>	<input type="radio"/>	<input type="radio"/>	<input type="radio"/>	<input type="radio"/>	<input type="radio"/>	<input type="radio"/>	
28. On average, how many hours per week have you spent on this course, including attending classes, doing readings, reviewing notes, writing papers and any other course related work?	<input type="radio"/> Under 2 <input type="radio"/> 2 - 3 <input type="radio"/> 4 - 5	<input type="radio"/> 6 - 7 <input type="radio"/> 8 - 9 <input type="radio"/> 10 - 11	<input type="radio"/> 12 - 13 <input type="radio"/> 14 - 15 <input type="radio"/> 16 - 17	<input type="radio"/> 18 - 19 <input type="radio"/> 20 - 21 <input type="radio"/> 22 or more				
29. From the total average hours above, how many do you consider were valuable in advancing your education?	<input type="radio"/> Under 2 <input type="radio"/> 2 - 3 <input type="radio"/> 4 - 5	<input type="radio"/> 6 - 7 <input type="radio"/> 8 - 9 <input type="radio"/> 10 - 11	<input type="radio"/> 12 - 13 <input type="radio"/> 14 - 15 <input type="radio"/> 16 - 17	<input type="radio"/> 18 - 19 <input type="radio"/> 20 - 21 <input type="radio"/> 22 or more				
30. What grade do you expect in this course?	<input type="radio"/> A (3.9-4.0) <input type="radio"/> A- (3.5-3.8) <input type="radio"/> B+ (3.2-3.4)	<input type="radio"/> B (2.9-3.1) <input type="radio"/> B- (2.5-2.8) <input type="radio"/> C+ (2.2-2.4)	<input type="radio"/> C (1.9-2.1) <input type="radio"/> C- (1.5-1.8) <input type="radio"/> D+ (1.2-1.4)	<input type="radio"/> D (0.9-1.1) <input type="radio"/> D- (0.7-0.8) <input type="radio"/> E (0.0)	<input type="radio"/> Pass <input type="radio"/> Credit <input type="radio"/> No Credit			
31. In regard to your academic program, is this course best described as:	<input type="radio"/> In your major? <input type="radio"/> In your minor?	<input type="radio"/> A distribution requirement? <input type="radio"/> A program requirement?	<input type="radio"/> An elective? <input type="radio"/> Other?					

Mark Reflex® by NCS MM89765-2 151413 ED06 Printed in U.S.A. ©1995, University of Washington - Office of Educational Assessment

# Instructional Assessment System

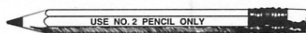

Fill in bubbles darkly and completely.  
Erase errors cleanly.

SMSTI JAHOTIGDA  
bataentib it'frio waU

FORM  
**B**

Instructor \_\_\_\_\_ Course \_\_\_\_\_ Section \_\_\_\_\_ Date \_\_\_\_\_

Completion of this questionnaire is voluntary. You are free to leave some or all questions unanswered.

	Excel- lent	Very Good	Good	Fair	Poor	Very Poor
1. The course as a whole was:	<input type="radio"/>	<input type="radio"/>	<input type="radio"/>	<input type="radio"/>	<input type="radio"/>	<input type="radio"/>
2. The course content was:	<input type="radio"/>	<input type="radio"/>	<input type="radio"/>	<input type="radio"/>	<input type="radio"/>	<input type="radio"/>
3. The instructor's contribution to the course was:	<input type="radio"/>	<input type="radio"/>	<input type="radio"/>	<input type="radio"/>	<input type="radio"/>	<input type="radio"/>
4. The instructor's effectiveness in teaching the subject matter was:	<input type="radio"/>	<input type="radio"/>	<input type="radio"/>	<input type="radio"/>	<input type="radio"/>	<input type="radio"/>
5. Course organization was:	<input type="radio"/>	<input type="radio"/>	<input type="radio"/>	<input type="radio"/>	<input type="radio"/>	<input type="radio"/>
6. Sequential presentation of concepts was:	<input type="radio"/>	<input type="radio"/>	<input type="radio"/>	<input type="radio"/>	<input type="radio"/>	<input type="radio"/>
7. Explanations by instructor were:	<input type="radio"/>	<input type="radio"/>	<input type="radio"/>	<input type="radio"/>	<input type="radio"/>	<input type="radio"/>
8. Instructor's ability to present alternative explanations when needed was:	<input type="radio"/>	<input type="radio"/>	<input type="radio"/>	<input type="radio"/>	<input type="radio"/>	<input type="radio"/>
9. Instructor's use of examples and illustrations was:	<input type="radio"/>	<input type="radio"/>	<input type="radio"/>	<input type="radio"/>	<input type="radio"/>	<input type="radio"/>
10. Instructor's enhancement of student interest in the material was:	<input type="radio"/>	<input type="radio"/>	<input type="radio"/>	<input type="radio"/>	<input type="radio"/>	<input type="radio"/>
11. Student confidence in instructor's knowledge was:	<input type="radio"/>	<input type="radio"/>	<input type="radio"/>	<input type="radio"/>	<input type="radio"/>	<input type="radio"/>
12. Instructor's enthusiasm was:	<input type="radio"/>	<input type="radio"/>	<input type="radio"/>	<input type="radio"/>	<input type="radio"/>	<input type="radio"/>
13. Clarity of course objectives was:	<input type="radio"/>	<input type="radio"/>	<input type="radio"/>	<input type="radio"/>	<input type="radio"/>	<input type="radio"/>
14. Interest level of class sessions was:	<input type="radio"/>	<input type="radio"/>	<input type="radio"/>	<input type="radio"/>	<input type="radio"/>	<input type="radio"/>
15. Availability of extra help when needed was:	<input type="radio"/>	<input type="radio"/>	<input type="radio"/>	<input type="radio"/>	<input type="radio"/>	<input type="radio"/>
16. Use of class time was:	<input type="radio"/>	<input type="radio"/>	<input type="radio"/>	<input type="radio"/>	<input type="radio"/>	<input type="radio"/>
17. Instructor's interest in whether students learned was:	<input type="radio"/>	<input type="radio"/>	<input type="radio"/>	<input type="radio"/>	<input type="radio"/>	<input type="radio"/>
18. Amount you learned in the course was:	<input type="radio"/>	<input type="radio"/>	<input type="radio"/>	<input type="radio"/>	<input type="radio"/>	<input type="radio"/>
19. Relevance and usefulness of course content were:	<input type="radio"/>	<input type="radio"/>	<input type="radio"/>	<input type="radio"/>	<input type="radio"/>	<input type="radio"/>
20. Evaluative and grading techniques (tests, papers, projects, etc.) were:	<input type="radio"/>	<input type="radio"/>	<input type="radio"/>	<input type="radio"/>	<input type="radio"/>	<input type="radio"/>
21. Reasonableness of assigned work was:	<input type="radio"/>	<input type="radio"/>	<input type="radio"/>	<input type="radio"/>	<input type="radio"/>	<input type="radio"/>
22. Clarity of student responsibilities and requirements was:	<input type="radio"/>	<input type="radio"/>	<input type="radio"/>	<input type="radio"/>	<input type="radio"/>	<input type="radio"/>

**Relative to other college courses you have taken:**

	Much Higher	Average	Much Lower		
23. Do you expect your grade in this course to be:	<input type="radio"/>	<input type="radio"/>	<input type="radio"/>		
24. The intellectual challenge presented was:	<input type="radio"/>	<input type="radio"/>	<input type="radio"/>		
25. The amount of effort you put into this course was:	<input type="radio"/>	<input type="radio"/>	<input type="radio"/>		
26. The amount of effort to succeed in this course was:	<input type="radio"/>	<input type="radio"/>	<input type="radio"/>		
27. Your involvement in this course (doing assignments, attending classes, etc.) was:	<input type="radio"/>	<input type="radio"/>	<input type="radio"/>		
28. On average, how many hours per week have you spent on this course, including attending classes, doing readings, reviewing notes, writing papers and any other course related work?	<input type="radio"/> Under 2 <input type="radio"/> 2 - 3 <input type="radio"/> 4 - 5	<input type="radio"/> 6 - 7 <input type="radio"/> 8 - 9 <input type="radio"/> 10 - 11	<input type="radio"/> 12 - 13 <input type="radio"/> 14 - 15 <input type="radio"/> 16 - 17	<input type="radio"/> 18 - 19 <input type="radio"/> 20 - 21 <input type="radio"/> 22 or more	
29. From the total average hours above, how many do you consider were valuable in advancing your education?	<input type="radio"/> Under 2 <input type="radio"/> 2 - 3 <input type="radio"/> 4 - 5	<input type="radio"/> 6 - 7 <input type="radio"/> 8 - 9 <input type="radio"/> 10 - 11	<input type="radio"/> 12 - 13 <input type="radio"/> 14 - 15 <input type="radio"/> 16 - 17	<input type="radio"/> 18 - 19 <input type="radio"/> 20 - 21 <input type="radio"/> 22 or more	
30. What grade do you expect in this course?	<input type="radio"/> A (3.9-4.0) <input type="radio"/> A- (3.5-3.8) <input type="radio"/> B+ (3.2-3.4)	<input type="radio"/> B (2.9-3.1) <input type="radio"/> B- (2.5-2.8) <input type="radio"/> C+ (2.2-2.4)	<input type="radio"/> C (1.9-2.1) <input type="radio"/> C- (1.5-1.8) <input type="radio"/> D+ (1.2-1.4)	<input type="radio"/> D (0.9-1.1) <input type="radio"/> D- (0.7-0.8) <input type="radio"/> E (0.0)	<input type="radio"/> Pass <input type="radio"/> Credit <input type="radio"/> No Credit
31. In regard to your academic program, is this course best described as:	<input type="radio"/> In your major? <input type="radio"/> In your minor?	<input type="radio"/> A distribution requirement? <input type="radio"/> A program requirement?	<input type="radio"/> An elective? <input type="radio"/> Other?		



# Instructional Assessment System

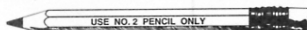

Fill in bubbles darkly and completely.  
Erase errors cleanly.

ADDITIONAL ITEMS  
Use only if directed

FORM  
**C**

Instructor \_\_\_\_\_ Course \_\_\_\_\_ Section \_\_\_\_\_ Date \_\_\_\_\_

Completion of this questionnaire is voluntary. You are free to leave some or all questions unanswered.

	Excel- lent	Very Good	Good	Fair	Poor	Very Poor
1. The course as a whole was:	<input type="radio"/>	<input type="radio"/>	<input type="radio"/>	<input type="radio"/>	<input type="radio"/>	<input type="radio"/>
2. The course content was:	<input type="radio"/>	<input type="radio"/>	<input type="radio"/>	<input type="radio"/>	<input type="radio"/>	<input type="radio"/>
3. The instructor's contribution to the course was:	<input type="radio"/>	<input type="radio"/>	<input type="radio"/>	<input type="radio"/>	<input type="radio"/>	<input type="radio"/>
4. The instructor's effectiveness in teaching the subject matter was:	<input type="radio"/>	<input type="radio"/>	<input type="radio"/>	<input type="radio"/>	<input type="radio"/>	<input type="radio"/>
5. Course organization was:	<input type="radio"/>	<input type="radio"/>	<input type="radio"/>	<input type="radio"/>	<input type="radio"/>	<input type="radio"/>
6. Instructor's preparation for class was:	<input type="radio"/>	<input type="radio"/>	<input type="radio"/>	<input type="radio"/>	<input type="radio"/>	<input type="radio"/>
7. Instructor as a discussion leader was:	<input type="radio"/>	<input type="radio"/>	<input type="radio"/>	<input type="radio"/>	<input type="radio"/>	<input type="radio"/>
8. Instructor's contribution to discussion was:	<input type="radio"/>	<input type="radio"/>	<input type="radio"/>	<input type="radio"/>	<input type="radio"/>	<input type="radio"/>
9. Conduciveness of class atmosphere to student learning was:	<input type="radio"/>	<input type="radio"/>	<input type="radio"/>	<input type="radio"/>	<input type="radio"/>	<input type="radio"/>
10. Quality of questions or problems raised was:	<input type="radio"/>	<input type="radio"/>	<input type="radio"/>	<input type="radio"/>	<input type="radio"/>	<input type="radio"/>
11. Student confidence in instructor's knowledge was:	<input type="radio"/>	<input type="radio"/>	<input type="radio"/>	<input type="radio"/>	<input type="radio"/>	<input type="radio"/>
12. Instructor's enthusiasm was:	<input type="radio"/>	<input type="radio"/>	<input type="radio"/>	<input type="radio"/>	<input type="radio"/>	<input type="radio"/>
13. Encouragement given students to express themselves was:	<input type="radio"/>	<input type="radio"/>	<input type="radio"/>	<input type="radio"/>	<input type="radio"/>	<input type="radio"/>
14. Instructor's openness to student views was:	<input type="radio"/>	<input type="radio"/>	<input type="radio"/>	<input type="radio"/>	<input type="radio"/>	<input type="radio"/>
15. Interest level of class sessions was:	<input type="radio"/>	<input type="radio"/>	<input type="radio"/>	<input type="radio"/>	<input type="radio"/>	<input type="radio"/>
16. Use of class time was:	<input type="radio"/>	<input type="radio"/>	<input type="radio"/>	<input type="radio"/>	<input type="radio"/>	<input type="radio"/>
17. Instructor's interest in whether students learned was:	<input type="radio"/>	<input type="radio"/>	<input type="radio"/>	<input type="radio"/>	<input type="radio"/>	<input type="radio"/>
18. Amount you learned in the course was:	<input type="radio"/>	<input type="radio"/>	<input type="radio"/>	<input type="radio"/>	<input type="radio"/>	<input type="radio"/>
19. Relevance and usefulness of course content were:	<input type="radio"/>	<input type="radio"/>	<input type="radio"/>	<input type="radio"/>	<input type="radio"/>	<input type="radio"/>
20. Evaluative and grading techniques (tests, papers, projects, etc.) were:	<input type="radio"/>	<input type="radio"/>	<input type="radio"/>	<input type="radio"/>	<input type="radio"/>	<input type="radio"/>
21. Reasonableness of assigned work was:	<input type="radio"/>	<input type="radio"/>	<input type="radio"/>	<input type="radio"/>	<input type="radio"/>	<input type="radio"/>
22. Clarity of student responsibilities and requirements was:	<input type="radio"/>	<input type="radio"/>	<input type="radio"/>	<input type="radio"/>	<input type="radio"/>	<input type="radio"/>

**Relative to other college courses you have taken:**

	Much Higher	Average	Much Lower
23. Do you expect your grade in this course to be:	<input type="radio"/>	<input type="radio"/>	<input type="radio"/>
24. The intellectual challenge presented was:	<input type="radio"/>	<input type="radio"/>	<input type="radio"/>
25. The amount of effort you put into this course was:	<input type="radio"/>	<input type="radio"/>	<input type="radio"/>
26. The amount of effort to succeed in this course was:	<input type="radio"/>	<input type="radio"/>	<input type="radio"/>
27. Your involvement in this course (doing assignments, attending classes, etc.) was:	<input type="radio"/>	<input type="radio"/>	<input type="radio"/>

28. On average, how many hours per week have you spent on this course, including attending classes, doing readings, reviewing notes, writing papers and any other course related work?

<input type="radio"/> Under 2	<input type="radio"/> 6 - 7	<input type="radio"/> 12 - 13	<input type="radio"/> 18 - 19
<input type="radio"/> 2 - 3	<input type="radio"/> 8 - 9	<input type="radio"/> 14 - 15	<input type="radio"/> 20 - 21
<input type="radio"/> 4 - 5	<input type="radio"/> 10 - 11	<input type="radio"/> 16 - 17	<input type="radio"/> 22 or more

29. From the total average hours above, how many do you consider were valuable in advancing your education?

<input type="radio"/> Under 2	<input type="radio"/> 6 - 7	<input type="radio"/> 12 - 13	<input type="radio"/> 18 - 19
<input type="radio"/> 2 - 3	<input type="radio"/> 8 - 9	<input type="radio"/> 14 - 15	<input type="radio"/> 20 - 21
<input type="radio"/> 4 - 5	<input type="radio"/> 10 - 11	<input type="radio"/> 16 - 17	<input type="radio"/> 22 or more

30. What grade do you expect in this course?

<input type="radio"/> A (3.9-4.0)	<input type="radio"/> B (2.9-3.1)	<input type="radio"/> C (1.9-2.1)	<input type="radio"/> D (0.9-1.1)	<input type="radio"/> Pass
<input type="radio"/> A- (3.5-3.8)	<input type="radio"/> B- (2.5-2.8)	<input type="radio"/> C- (1.5-1.8)	<input type="radio"/> D- (0.7-0.8)	<input type="radio"/> Credit
<input type="radio"/> B+ (3.2-3.4)	<input type="radio"/> C+ (2.2-2.4)	<input type="radio"/> D+ (1.2-1.4)	<input type="radio"/> E (0.0)	<input type="radio"/> No Credit

31. In regard to your academic program, is this course best described as:

<input type="radio"/> In your major?	<input type="radio"/> A distribution requirement?	<input type="radio"/> An elective?
<input type="radio"/> In your minor?	<input type="radio"/> A program requirement?	<input type="radio"/> Other?

# Instructional Assessment System

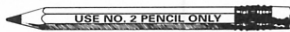

Fill in bubbles darkly and completely.  
Erase errors cleanly.

FORM  
**D**

Instructor \_\_\_\_\_ Course \_\_\_\_\_ Section \_\_\_\_\_ Date \_\_\_\_\_

Completion of this questionnaire is voluntary. You are free to leave some or all questions unanswered.

	Excel- lent	Very Good	Good	Fair	Poor	Very Poor
1. The course as a whole was:	<input type="radio"/>	<input type="radio"/>	<input type="radio"/>	<input type="radio"/>	<input type="radio"/>	<input type="radio"/>
2. The course content was:	<input type="radio"/>	<input type="radio"/>	<input type="radio"/>	<input type="radio"/>	<input type="radio"/>	<input type="radio"/>
3. The instructor's contribution to the course was:	<input type="radio"/>	<input type="radio"/>	<input type="radio"/>	<input type="radio"/>	<input type="radio"/>	<input type="radio"/>
4. The instructor's effectiveness in teaching the subject matter was:	<input type="radio"/>	<input type="radio"/>	<input type="radio"/>	<input type="radio"/>	<input type="radio"/>	<input type="radio"/>
5. Course organization was:	<input type="radio"/>	<input type="radio"/>	<input type="radio"/>	<input type="radio"/>	<input type="radio"/>	<input type="radio"/>
6. Sequential presentation of concepts was:	<input type="radio"/>	<input type="radio"/>	<input type="radio"/>	<input type="radio"/>	<input type="radio"/>	<input type="radio"/>
7. Explanations by instructor were:	<input type="radio"/>	<input type="radio"/>	<input type="radio"/>	<input type="radio"/>	<input type="radio"/>	<input type="radio"/>
8. Instructor's ability to present alternative explanations when needed was:	<input type="radio"/>	<input type="radio"/>	<input type="radio"/>	<input type="radio"/>	<input type="radio"/>	<input type="radio"/>
9. Instructor's use of examples and illustrations was:	<input type="radio"/>	<input type="radio"/>	<input type="radio"/>	<input type="radio"/>	<input type="radio"/>	<input type="radio"/>
10. Quality of questions or problems raised by the instructor was:	<input type="radio"/>	<input type="radio"/>	<input type="radio"/>	<input type="radio"/>	<input type="radio"/>	<input type="radio"/>
11. Contribution of assignments to understanding course content was:	<input type="radio"/>	<input type="radio"/>	<input type="radio"/>	<input type="radio"/>	<input type="radio"/>	<input type="radio"/>
12. Instructor's enthusiasm was:	<input type="radio"/>	<input type="radio"/>	<input type="radio"/>	<input type="radio"/>	<input type="radio"/>	<input type="radio"/>
13. Instructor's ability to deal with student difficulties was:	<input type="radio"/>	<input type="radio"/>	<input type="radio"/>	<input type="radio"/>	<input type="radio"/>	<input type="radio"/>
14. Answers to student questions were:	<input type="radio"/>	<input type="radio"/>	<input type="radio"/>	<input type="radio"/>	<input type="radio"/>	<input type="radio"/>
15. Availability of extra help when needed was:	<input type="radio"/>	<input type="radio"/>	<input type="radio"/>	<input type="radio"/>	<input type="radio"/>	<input type="radio"/>
16. Use of class time was:	<input type="radio"/>	<input type="radio"/>	<input type="radio"/>	<input type="radio"/>	<input type="radio"/>	<input type="radio"/>
17. Instructor's interest in whether students learned was:	<input type="radio"/>	<input type="radio"/>	<input type="radio"/>	<input type="radio"/>	<input type="radio"/>	<input type="radio"/>
18. Amount you learned in the course was:	<input type="radio"/>	<input type="radio"/>	<input type="radio"/>	<input type="radio"/>	<input type="radio"/>	<input type="radio"/>
19. Relevance and usefulness of course content were:	<input type="radio"/>	<input type="radio"/>	<input type="radio"/>	<input type="radio"/>	<input type="radio"/>	<input type="radio"/>
20. Evaluative and grading techniques (tests, papers, projects, etc.) were:	<input type="radio"/>	<input type="radio"/>	<input type="radio"/>	<input type="radio"/>	<input type="radio"/>	<input type="radio"/>
21. Reasonableness of assigned work was:	<input type="radio"/>	<input type="radio"/>	<input type="radio"/>	<input type="radio"/>	<input type="radio"/>	<input type="radio"/>
22. Clarity of student responsibilities and requirements was:	<input type="radio"/>	<input type="radio"/>	<input type="radio"/>	<input type="radio"/>	<input type="radio"/>	<input type="radio"/>

	Much Higher	Average	Much Lower	
23. Do you expect your grade in this course to be:	<input type="radio"/>	<input type="radio"/>	<input type="radio"/>	
24. The intellectual challenge presented was:	<input type="radio"/>	<input type="radio"/>	<input type="radio"/>	
25. The amount of effort you put into this course was:	<input type="radio"/>	<input type="radio"/>	<input type="radio"/>	
26. The amount of effort to succeed in this course was:	<input type="radio"/>	<input type="radio"/>	<input type="radio"/>	
27. Your involvement in this course (doing assignments, attending classes, etc.) was:	<input type="radio"/>	<input type="radio"/>	<input type="radio"/>	
28. On average, how many hours per week have you spent on this course, including attending classes, doing readings, reviewing notes, writing papers and any other course related work?	<input type="radio"/> Under 2 <input type="radio"/> 2 - 3 <input type="radio"/> 4 - 5	<input type="radio"/> 6 - 7 <input type="radio"/> 8 - 9 <input type="radio"/> 10 - 11	<input type="radio"/> 12 - 13 <input type="radio"/> 14 - 15 <input type="radio"/> 16 - 17	<input type="radio"/> 18 - 19 <input type="radio"/> 20 - 21 <input type="radio"/> 22 or more
29. From the total average hours above, how many do you consider were valuable in advancing your education?	<input type="radio"/> Under 2 <input type="radio"/> 2 - 3 <input type="radio"/> 4 - 5	<input type="radio"/> 6 - 7 <input type="radio"/> 8 - 9 <input type="radio"/> 10 - 11	<input type="radio"/> 12 - 13 <input type="radio"/> 14 - 15 <input type="radio"/> 16 - 17	<input type="radio"/> 18 - 19 <input type="radio"/> 20 - 21 <input type="radio"/> 22 or more
30. What grade do you expect in this course?	<input type="radio"/> A (3.9-4.0) <input type="radio"/> A- (3.5-3.8) <input type="radio"/> B+ (3.2-3.4)	<input type="radio"/> B (2.9-3.1) <input type="radio"/> B- (2.5-2.8) <input type="radio"/> C+ (2.2-2.4)	<input type="radio"/> C (1.9-2.1) <input type="radio"/> C- (1.5-1.8) <input type="radio"/> D+ (1.2-1.4)	<input type="radio"/> D (0.9-1.1) <input type="radio"/> D- (0.7-0.8) <input type="radio"/> E (0.0)
	<input type="radio"/> Pass <input type="radio"/> Credit <input type="radio"/> No Credit			
31. In regard to your academic program, is this course best described as:	<input type="radio"/> In your major? <input type="radio"/> In your minor?	<input type="radio"/> A distribution requirement? <input type="radio"/> A program requirement?	<input type="radio"/> An elective? <input type="radio"/> Other?	

# Instructional Assessment System

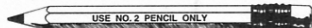

Fill in bubbles darkly and completely.  
Erase errors cleanly.

FORM  
**E**

Instructor \_\_\_\_\_ Course \_\_\_\_\_ Section \_\_\_\_\_ Date \_\_\_\_\_

Completion of this questionnaire is voluntary. You are free to leave some or all questions unanswered.

	Excel- lent	Very Good	Good	Fair	Poor	Very Poor
1. The course as a whole was:	<input type="radio"/>	<input type="radio"/>	<input type="radio"/>	<input type="radio"/>	<input type="radio"/>	<input type="radio"/>
2. The course content was:	<input type="radio"/>	<input type="radio"/>	<input type="radio"/>	<input type="radio"/>	<input type="radio"/>	<input type="radio"/>
3. The instructor's contribution to the course was:	<input type="radio"/>	<input type="radio"/>	<input type="radio"/>	<input type="radio"/>	<input type="radio"/>	<input type="radio"/>
4. The instructor's effectiveness in teaching the subject matter was:	<input type="radio"/>	<input type="radio"/>	<input type="radio"/>	<input type="radio"/>	<input type="radio"/>	<input type="radio"/>
5. Opportunity for practicing what was learned was:	<input type="radio"/>	<input type="radio"/>	<input type="radio"/>	<input type="radio"/>	<input type="radio"/>	<input type="radio"/>
6. Sequential development of skills was:	<input type="radio"/>	<input type="radio"/>	<input type="radio"/>	<input type="radio"/>	<input type="radio"/>	<input type="radio"/>
7. Explanations of underlying rationales for new techniques or skills were:	<input type="radio"/>	<input type="radio"/>	<input type="radio"/>	<input type="radio"/>	<input type="radio"/>	<input type="radio"/>
8. Demonstrations of expected skills were:	<input type="radio"/>	<input type="radio"/>	<input type="radio"/>	<input type="radio"/>	<input type="radio"/>	<input type="radio"/>
9. Instructor's confidence in students' ability was:	<input type="radio"/>	<input type="radio"/>	<input type="radio"/>	<input type="radio"/>	<input type="radio"/>	<input type="radio"/>
10. Recognition of student progress by instructor was:	<input type="radio"/>	<input type="radio"/>	<input type="radio"/>	<input type="radio"/>	<input type="radio"/>	<input type="radio"/>
11. Student confidence in instructor's knowledge was:	<input type="radio"/>	<input type="radio"/>	<input type="radio"/>	<input type="radio"/>	<input type="radio"/>	<input type="radio"/>
12. Freedom allowed students to develop own skills and ideas was:	<input type="radio"/>	<input type="radio"/>	<input type="radio"/>	<input type="radio"/>	<input type="radio"/>	<input type="radio"/>
13. Instructor's ability to deal with student difficulties was:	<input type="radio"/>	<input type="radio"/>	<input type="radio"/>	<input type="radio"/>	<input type="radio"/>	<input type="radio"/>
14. Tailoring of instruction to varying student skill levels was:	<input type="radio"/>	<input type="radio"/>	<input type="radio"/>	<input type="radio"/>	<input type="radio"/>	<input type="radio"/>
15. Availability of extra help when needed was:	<input type="radio"/>	<input type="radio"/>	<input type="radio"/>	<input type="radio"/>	<input type="radio"/>	<input type="radio"/>
16. Use of class time was:	<input type="radio"/>	<input type="radio"/>	<input type="radio"/>	<input type="radio"/>	<input type="radio"/>	<input type="radio"/>
17. Instructor's interest in whether students learned was:	<input type="radio"/>	<input type="radio"/>	<input type="radio"/>	<input type="radio"/>	<input type="radio"/>	<input type="radio"/>
18. Amount you learned in the course was:	<input type="radio"/>	<input type="radio"/>	<input type="radio"/>	<input type="radio"/>	<input type="radio"/>	<input type="radio"/>
19. Relevance and usefulness of course content were:	<input type="radio"/>	<input type="radio"/>	<input type="radio"/>	<input type="radio"/>	<input type="radio"/>	<input type="radio"/>
20. Evaluative and grading techniques (tests, papers, projects, etc.) were:	<input type="radio"/>	<input type="radio"/>	<input type="radio"/>	<input type="radio"/>	<input type="radio"/>	<input type="radio"/>
21. Reasonableness of assigned work was:	<input type="radio"/>	<input type="radio"/>	<input type="radio"/>	<input type="radio"/>	<input type="radio"/>	<input type="radio"/>
22. Clarity of student responsibilities and requirements was:	<input type="radio"/>	<input type="radio"/>	<input type="radio"/>	<input type="radio"/>	<input type="radio"/>	<input type="radio"/>

	Much Higher	Average	Much Lower	
23. Do you expect your grade in this course to be:	<input type="radio"/>	<input type="radio"/>	<input type="radio"/>	
24. The intellectual challenge presented was:	<input type="radio"/>	<input type="radio"/>	<input type="radio"/>	
25. The amount of effort you put into this course was:	<input type="radio"/>	<input type="radio"/>	<input type="radio"/>	
26. The amount of effort to succeed in this course was:	<input type="radio"/>	<input type="radio"/>	<input type="radio"/>	
27. Your involvement in this course (doing assignments, attending classes, etc.) was:	<input type="radio"/>	<input type="radio"/>	<input type="radio"/>	
28. On average, how many hours per week have you spent on this course, including attending classes, doing readings, reviewing notes, writing papers and any other course related work?	<input type="radio"/> Under 2 <input type="radio"/> 2 - 3 <input type="radio"/> 4 - 5	<input type="radio"/> 6 - 7 <input type="radio"/> 8 - 9 <input type="radio"/> 10 - 11	<input type="radio"/> 12 - 13 <input type="radio"/> 14 - 15 <input type="radio"/> 16 - 17	<input type="radio"/> 18 - 19 <input type="radio"/> 20 - 21 <input type="radio"/> 22 or more
29. From the total average hours above, how many do you consider were valuable in advancing your education?	<input type="radio"/> Under 2 <input type="radio"/> 2 - 3 <input type="radio"/> 4 - 5	<input type="radio"/> 6 - 7 <input type="radio"/> 8 - 9 <input type="radio"/> 10 - 11	<input type="radio"/> 12 - 13 <input type="radio"/> 14 - 15 <input type="radio"/> 16 - 17	<input type="radio"/> 18 - 19 <input type="radio"/> 20 - 21 <input type="radio"/> 22 or more
30. What grade do you expect in this course?	<input type="radio"/> A (3.9-4.0) <input type="radio"/> A- (3.5-3.8) <input type="radio"/> B+ (3.2-3.4)	<input type="radio"/> B (2.9-3.1) <input type="radio"/> B- (2.5-2.8) <input type="radio"/> C+ (2.2-2.4)	<input type="radio"/> C (1.9-2.1) <input type="radio"/> C- (1.5-1.8) <input type="radio"/> D+ (1.2-1.4)	<input type="radio"/> D (0.9-1.1) <input type="radio"/> D- (0.7-0.8) <input type="radio"/> E (0.0)
31. In regard to your academic program, is this course best described as:	<input type="radio"/> In your major? <input type="radio"/> In your minor?	<input type="radio"/> A distribution requirement? <input type="radio"/> A program requirement?	<input type="radio"/> An elective? <input type="radio"/> Other?	

# Instructional Assessment System



Fill in bubbles darkly and completely.  
Erase errors cleanly.

FORM  
**F**

Instructor \_\_\_\_\_ Course \_\_\_\_\_ Section \_\_\_\_\_ Date \_\_\_\_\_

Completion of this questionnaire is voluntary. You are free to leave some or all questions unanswered.

- |  | Excel-<br>lent        | Very<br>Good          | Good                  | Fair                  | Poor                  | Very<br>Poor          |   |
|--|-----------------------|-----------------------|-----------------------|-----------------------|-----------------------|-----------------------|---|
| 1. The quiz section as a whole was:                                      | <input type="radio"/> | <input type="radio"/> | <input type="radio"/> | <input type="radio"/> | <input type="radio"/> | <input type="radio"/> | ■ |
| 2. The content of the quiz section was:                                  | <input type="radio"/> | <input type="radio"/> | <input type="radio"/> | <input type="radio"/> | <input type="radio"/> | <input type="radio"/> | ■ |
| 3. The quiz section instructor's (QSI's) contribution to the course was: | <input type="radio"/> | <input type="radio"/> | <input type="radio"/> | <input type="radio"/> | <input type="radio"/> | <input type="radio"/> | ■ |
| 4. The QSI's effectiveness in teaching the subject matter was:           | <input type="radio"/> | <input type="radio"/> | <input type="radio"/> | <input type="radio"/> | <input type="radio"/> | <input type="radio"/> | ■ |
| 5. Explanations by the QSI were:   | <input type="radio"/> | <input type="radio"/> | <input type="radio"/> | <input type="radio"/> | <input type="radio"/> | <input type="radio"/> | ■ |
| 6. QSI's use of examples and illustrations was:                          | <input type="radio"/> | <input type="radio"/> | <input type="radio"/> | <input type="radio"/> | <input type="radio"/> | <input type="radio"/> | ■ |
| 7. Quality of questions or problems raised by QSI was:                   | <input type="radio"/> | <input type="radio"/> | <input type="radio"/> | <input type="radio"/> | <input type="radio"/> | <input type="radio"/> | ■ |
| 8. QSI's enthusiasm was:   | <input type="radio"/> | <input type="radio"/> | <input type="radio"/> | <input type="radio"/> | <input type="radio"/> | <input type="radio"/> | ■ |
| 9. Student confidence in QSI's knowledge was:                            | <input type="radio"/> | <input type="radio"/> | <input type="radio"/> | <input type="radio"/> | <input type="radio"/> | <input type="radio"/> | ■ |
| 10. Encouragement given students to express themselves was:              | <input type="radio"/> | <input type="radio"/> | <input type="radio"/> | <input type="radio"/> | <input type="radio"/> | <input type="radio"/> | ■ |
| 11. Answers to student questions were:                                   | <input type="radio"/> | <input type="radio"/> | <input type="radio"/> | <input type="radio"/> | <input type="radio"/> | <input type="radio"/> | ■ |
| 12. Interest level of quiz sections was:                                 | <input type="radio"/> | <input type="radio"/> | <input type="radio"/> | <input type="radio"/> | <input type="radio"/> | <input type="radio"/> | ■ |
| 13. QSI's openness to student views was:                                 | <input type="radio"/> | <input type="radio"/> | <input type="radio"/> | <input type="radio"/> | <input type="radio"/> | <input type="radio"/> | ■ |
| 14. QSI's ability to deal with student difficulties was:                 | <input type="radio"/> | <input type="radio"/> | <input type="radio"/> | <input type="radio"/> | <input type="radio"/> | <input type="radio"/> | ■ |
| 15. Availability of extra help when needed was:                          | <input type="radio"/> | <input type="radio"/> | <input type="radio"/> | <input type="radio"/> | <input type="radio"/> | <input type="radio"/> | ■ |
| 16. Use of quiz section time was:  | <input type="radio"/> | <input type="radio"/> | <input type="radio"/> | <input type="radio"/> | <input type="radio"/> | <input type="radio"/> | ■ |
| 17. QSI's interest in whether students learned was:                      | <input type="radio"/> | <input type="radio"/> | <input type="radio"/> | <input type="radio"/> | <input type="radio"/> | <input type="radio"/> | ■ |
| 18. Amount you learned in the quiz sections was:                         | <input type="radio"/> | <input type="radio"/> | <input type="radio"/> | <input type="radio"/> | <input type="radio"/> | <input type="radio"/> | ■ |
| 19. Relevance and usefulness of quiz section content were:               | <input type="radio"/> | <input type="radio"/> | <input type="radio"/> | <input type="radio"/> | <input type="radio"/> | <input type="radio"/> | ■ |
| 20. Coordination between lectures and quiz sections was:                 | <input type="radio"/> | <input type="radio"/> | <input type="radio"/> | <input type="radio"/> | <input type="radio"/> | <input type="radio"/> | ■ |
| 21. Reasonableness of assigned work for quiz section was:                | <input type="radio"/> | <input type="radio"/> | <input type="radio"/> | <input type="radio"/> | <input type="radio"/> | <input type="radio"/> | ■ |
| 22. Clarity of student responsibilities and requirements was:            | <input type="radio"/> | <input type="radio"/> | <input type="radio"/> | <input type="radio"/> | <input type="radio"/> | <input type="radio"/> | ■ |

**Relative to other college courses you have taken:**

- |  | Much<br>Higher  | Average   | Much<br>Lower   |  |   |   |
|--|---|---|---|--|---|---|
| 23. Do you expect your grade in this course to be:   | <input type="radio"/>   | <input type="radio"/>   | <input type="radio"/>   | ■  |   |   |
| 24. The intellectual challenge presented was:  | <input type="radio"/>   | <input type="radio"/>   | <input type="radio"/>   | ■  |   |   |
| 25. The amount of effort you put into this course was:   | <input type="radio"/>   | <input type="radio"/>   | <input type="radio"/>   | ■  |   |   |
| 26. The amount of effort to succeed in this course was:  | <input type="radio"/>   | <input type="radio"/>   | <input type="radio"/>   | ■  |   |   |
| 27. Your involvement in this course (doing assignments, attending classes, etc.) was:  | <input type="radio"/>   | <input type="radio"/>   | <input type="radio"/>   | ■  |   |   |
| 28. On average, how many hours per week have you spent on this course, including attending classes, doing readings, reviewing notes, writing papers and any other course related work? | <input type="radio"/> Under 2<br><input type="radio"/> 2 - 3<br><input type="radio"/> 4 - 5                   | <input type="radio"/> 6 - 7<br><input type="radio"/> 8 - 9<br><input type="radio"/> 10 - 11                   | <input type="radio"/> 12 - 13<br><input type="radio"/> 14 - 15<br><input type="radio"/> 16 - 17               | <input type="radio"/> 18 - 19<br><input type="radio"/> 20 - 21<br><input type="radio"/> 22 or more       | ■   |   |
| 29. From the total average hours above, how many do you consider were valuable in advancing your education?  | <input type="radio"/> Under 2<br><input type="radio"/> 2 - 3<br><input type="radio"/> 4 - 5                   | <input type="radio"/> 6 - 7<br><input type="radio"/> 8 - 9<br><input type="radio"/> 10 - 11                   | <input type="radio"/> 12 - 13<br><input type="radio"/> 14 - 15<br><input type="radio"/> 16 - 17               | <input type="radio"/> 18 - 19<br><input type="radio"/> 20 - 21<br><input type="radio"/> 22 or more       | ■   |   |
| 30. What grade do you expect in this course?   | <input type="radio"/> A (3.9-4.0)<br><input type="radio"/> A- (3.5-3.8)<br><input type="radio"/> B+ (3.2-3.4) | <input type="radio"/> B (2.9-3.1)<br><input type="radio"/> B- (2.5-2.8)<br><input type="radio"/> C+ (2.2-2.4) | <input type="radio"/> C (1.9-2.1)<br><input type="radio"/> C- (1.5-1.8)<br><input type="radio"/> D+ (1.2-1.4) | <input type="radio"/> D (0.9-1.1)<br><input type="radio"/> D- (0.7-0.8)<br><input type="radio"/> E (0.0) | <input type="radio"/> Pass<br><input type="radio"/> Credit<br><input type="radio"/> No Credit | ■ |
| 31. In regard to your academic program, is this course best described as:  | <input type="radio"/> In your major?<br><input type="radio"/> In your minor?                                  | <input type="radio"/> A distribution requirement?<br><input type="radio"/> A program requirement?             | <input type="radio"/> An elective?<br><input type="radio"/> Other?  | ■  |   |   |

# Instructional Assessment System



Fill in bubbles darkly and completely.  
Erase errors cleanly.

FORM  
**G**

Instructor \_\_\_\_\_ Course \_\_\_\_\_ Section \_\_\_\_\_ Date \_\_\_\_\_

Completion of this questionnaire is voluntary. You are free to leave some or all questions unanswered.

	Excel- lent	Very Good	Good	Fair	Poor	Very Poor
1. The course as a whole was:	<input type="radio"/>	<input type="radio"/>	<input type="radio"/>	<input type="radio"/>	<input type="radio"/>	<input type="radio"/>
2. The course content was:	<input type="radio"/>	<input type="radio"/>	<input type="radio"/>	<input type="radio"/>	<input type="radio"/>	<input type="radio"/>
3. The instructor overall was:	<input type="radio"/>	<input type="radio"/>	<input type="radio"/>	<input type="radio"/>	<input type="radio"/>	<input type="radio"/>
4. The instructor's contribution to your understanding of concepts and ideas:	<input type="radio"/>	<input type="radio"/>	<input type="radio"/>	<input type="radio"/>	<input type="radio"/>	<input type="radio"/>
5. Course organization was:	<input type="radio"/>	<input type="radio"/>	<input type="radio"/>	<input type="radio"/>	<input type="radio"/>	<input type="radio"/>
6. Opportunity to ask questions was:	<input type="radio"/>	<input type="radio"/>	<input type="radio"/>	<input type="radio"/>	<input type="radio"/>	<input type="radio"/>
7. Explanations by instructor were:	<input type="radio"/>	<input type="radio"/>	<input type="radio"/>	<input type="radio"/>	<input type="radio"/>	<input type="radio"/>
8. Instructor's contribution to your ability to solve problems was:	<input type="radio"/>	<input type="radio"/>	<input type="radio"/>	<input type="radio"/>	<input type="radio"/>	<input type="radio"/>
9. Instructor's use of examples and illustrations was:	<input type="radio"/>	<input type="radio"/>	<input type="radio"/>	<input type="radio"/>	<input type="radio"/>	<input type="radio"/>
10. Length and difficulty of homework assignments were:	<input type="radio"/>	<input type="radio"/>	<input type="radio"/>	<input type="radio"/>	<input type="radio"/>	<input type="radio"/>
11. Contribution of examinations to understanding course content was:	<input type="radio"/>	<input type="radio"/>	<input type="radio"/>	<input type="radio"/>	<input type="radio"/>	<input type="radio"/>
12. Instructor's enthusiasm was:	<input type="radio"/>	<input type="radio"/>	<input type="radio"/>	<input type="radio"/>	<input type="radio"/>	<input type="radio"/>
13. The textbook overall was:	<input type="radio"/>	<input type="radio"/>	<input type="radio"/>	<input type="radio"/>	<input type="radio"/>	<input type="radio"/>
14. Answers to questions from class were:	<input type="radio"/>	<input type="radio"/>	<input type="radio"/>	<input type="radio"/>	<input type="radio"/>	<input type="radio"/>
15. Relationship between lectures and text was:	<input type="radio"/>	<input type="radio"/>	<input type="radio"/>	<input type="radio"/>	<input type="radio"/>	<input type="radio"/>
16. Availability of extra help when needed was:	<input type="radio"/>	<input type="radio"/>	<input type="radio"/>	<input type="radio"/>	<input type="radio"/>	<input type="radio"/>
17. Instructor's interest in whether students learned was:	<input type="radio"/>	<input type="radio"/>	<input type="radio"/>	<input type="radio"/>	<input type="radio"/>	<input type="radio"/>
18. Amount you learned in the course was:	<input type="radio"/>	<input type="radio"/>	<input type="radio"/>	<input type="radio"/>	<input type="radio"/>	<input type="radio"/>
19. Relevance and usefulness of course content were:	<input type="radio"/>	<input type="radio"/>	<input type="radio"/>	<input type="radio"/>	<input type="radio"/>	<input type="radio"/>
20. Relevance and usefulness of homework assignments were:	<input type="radio"/>	<input type="radio"/>	<input type="radio"/>	<input type="radio"/>	<input type="radio"/>	<input type="radio"/>
21. Reasonableness of assigned work was:	<input type="radio"/>	<input type="radio"/>	<input type="radio"/>	<input type="radio"/>	<input type="radio"/>	<input type="radio"/>
22. Relationship of examinations to material emphasized in the course was:	<input type="radio"/>	<input type="radio"/>	<input type="radio"/>	<input type="radio"/>	<input type="radio"/>	<input type="radio"/>

**Relative to other college courses you have taken:**

	Much Higher	Average	Much Lower		
23. Do you expect your grade in this course to be:	<input type="radio"/>	<input type="radio"/>	<input type="radio"/>		
24. The intellectual challenge presented was:	<input type="radio"/>	<input type="radio"/>	<input type="radio"/>		
25. The amount of effort you put into this course was:	<input type="radio"/>	<input type="radio"/>	<input type="radio"/>		
26. The amount of effort to succeed in this course was:	<input type="radio"/>	<input type="radio"/>	<input type="radio"/>		
27. Your involvement in this course (doing assignments, attending classes, etc.) was:	<input type="radio"/>	<input type="radio"/>	<input type="radio"/>		
28. On average, how many hours per week have you spent on this course, including attending classes, doing readings, reviewing notes, writing papers and any other course related work?	<input type="radio"/> Under 2 <input type="radio"/> 2 - 3 <input type="radio"/> 4 - 5	<input type="radio"/> 6 - 7 <input type="radio"/> 8 - 9 <input type="radio"/> 10 - 11	<input type="radio"/> 12 - 13 <input type="radio"/> 14 - 15 <input type="radio"/> 16 - 17 <input type="radio"/> 18 - 19 <input type="radio"/> 20 - 21 <input type="radio"/> 22 or more		
29. From the total average hours above, how many do you consider were valuable in advancing your education?	<input type="radio"/> Under 2 <input type="radio"/> 2 - 3 <input type="radio"/> 4 - 5	<input type="radio"/> 6 - 7 <input type="radio"/> 8 - 9 <input type="radio"/> 10 - 11	<input type="radio"/> 12 - 13 <input type="radio"/> 14 - 15 <input type="radio"/> 16 - 17 <input type="radio"/> 18 - 19 <input type="radio"/> 20 - 21 <input type="radio"/> 22 or more		
30. What grade do you expect in this course?	<input type="radio"/> A (3.9-4.0) <input type="radio"/> A- (3.5-3.8) <input type="radio"/> B+ (3.2-3.4)	<input type="radio"/> B (2.9-3.1) <input type="radio"/> B- (2.5-2.8) <input type="radio"/> C+ (2.2-2.4)	<input type="radio"/> C (1.9-2.1) <input type="radio"/> C- (1.5-1.8) <input type="radio"/> D+ (1.2-1.4)	<input type="radio"/> D (0.9-1.1) <input type="radio"/> D- (0.7-0.8) <input type="radio"/> E (0.0)	<input type="radio"/> Pass <input type="radio"/> Credit <input type="radio"/> No Credit
31. In regard to your academic program, is this course best described as:	<input type="radio"/> In your major? <input type="radio"/> In your minor?	<input type="radio"/> A distribution requirement? <input type="radio"/> A program requirement?	<input type="radio"/> An elective? <input type="radio"/> Other?		



# Instructional Assessment System

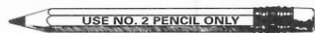

Fill in bubbles darkly and completely.  
Erase errors cleanly.

ADDITIONAL ITEMS  
Use only if directed

FORM  
**H**

Instructor \_\_\_\_\_ Course \_\_\_\_\_ Section \_\_\_\_\_ Date \_\_\_\_\_

Completion of this questionnaire is voluntary. You are free to leave some or all questions unanswered.

	Excel- lent	Very Good	Good	Fair	Poor	Very Poor
1. The lab section as a whole was:	<input type="radio"/>	<input type="radio"/>	<input type="radio"/>	<input type="radio"/>	<input type="radio"/>	<input type="radio"/>
2. The content of the lab section was:	<input type="radio"/>	<input type="radio"/>	<input type="radio"/>	<input type="radio"/>	<input type="radio"/>	<input type="radio"/>
3. The lab instructor's contribution to the course was:	<input type="radio"/>	<input type="radio"/>	<input type="radio"/>	<input type="radio"/>	<input type="radio"/>	<input type="radio"/>
4. The lab instructor's effectiveness in teaching the subject matter was:	<input type="radio"/>	<input type="radio"/>	<input type="radio"/>	<input type="radio"/>	<input type="radio"/>	<input type="radio"/>
5. Explanations by the lab instructor were:	<input type="radio"/>	<input type="radio"/>	<input type="radio"/>	<input type="radio"/>	<input type="radio"/>	<input type="radio"/>
6. Lab instructor's preparedness for lab sessions was:	<input type="radio"/>	<input type="radio"/>	<input type="radio"/>	<input type="radio"/>	<input type="radio"/>	<input type="radio"/>
7. Quality of questions or problems raised by the lab instructor was:	<input type="radio"/>	<input type="radio"/>	<input type="radio"/>	<input type="radio"/>	<input type="radio"/>	<input type="radio"/>
8. Lab instructor's enthusiasm was:	<input type="radio"/>	<input type="radio"/>	<input type="radio"/>	<input type="radio"/>	<input type="radio"/>	<input type="radio"/>
9. Student confidence in lab instructor's knowledge was:	<input type="radio"/>	<input type="radio"/>	<input type="radio"/>	<input type="radio"/>	<input type="radio"/>	<input type="radio"/>
10. Lab instructor's ability to solve unexpected problems was:	<input type="radio"/>	<input type="radio"/>	<input type="radio"/>	<input type="radio"/>	<input type="radio"/>	<input type="radio"/>
11. Answers to student questions were:	<input type="radio"/>	<input type="radio"/>	<input type="radio"/>	<input type="radio"/>	<input type="radio"/>	<input type="radio"/>
12. Interest level of lab sessions was:	<input type="radio"/>	<input type="radio"/>	<input type="radio"/>	<input type="radio"/>	<input type="radio"/>	<input type="radio"/>
13. Communication and enforcement of safety procedures were:	<input type="radio"/>	<input type="radio"/>	<input type="radio"/>	<input type="radio"/>	<input type="radio"/>	<input type="radio"/>
14. Lab instructor's ability to deal with student difficulties was:	<input type="radio"/>	<input type="radio"/>	<input type="radio"/>	<input type="radio"/>	<input type="radio"/>	<input type="radio"/>
15. Availability of extra help when needed was:	<input type="radio"/>	<input type="radio"/>	<input type="radio"/>	<input type="radio"/>	<input type="radio"/>	<input type="radio"/>
16. Use of lab section time was:	<input type="radio"/>	<input type="radio"/>	<input type="radio"/>	<input type="radio"/>	<input type="radio"/>	<input type="radio"/>
17. Lab instructor's interest in whether students learned was:	<input type="radio"/>	<input type="radio"/>	<input type="radio"/>	<input type="radio"/>	<input type="radio"/>	<input type="radio"/>
18. Amount you learned in the lab sections was:	<input type="radio"/>	<input type="radio"/>	<input type="radio"/>	<input type="radio"/>	<input type="radio"/>	<input type="radio"/>
19. Relevance and usefulness of lab section content were:	<input type="radio"/>	<input type="radio"/>	<input type="radio"/>	<input type="radio"/>	<input type="radio"/>	<input type="radio"/>
20. Coordination between lectures and lab activities was:	<input type="radio"/>	<input type="radio"/>	<input type="radio"/>	<input type="radio"/>	<input type="radio"/>	<input type="radio"/>
21. Reasonableness of assigned work for lab section was:	<input type="radio"/>	<input type="radio"/>	<input type="radio"/>	<input type="radio"/>	<input type="radio"/>	<input type="radio"/>
22. Clarity of student responsibilities and requirements was:	<input type="radio"/>	<input type="radio"/>	<input type="radio"/>	<input type="radio"/>	<input type="radio"/>	<input type="radio"/>

	Much Higher	Average	Much Lower	
23. Do you expect your grade in this course to be:	<input type="radio"/>	<input type="radio"/>	<input type="radio"/>	
24. The intellectual challenge presented was:	<input type="radio"/>	<input type="radio"/>	<input type="radio"/>	
25. The amount of effort you put into this course was:	<input type="radio"/>	<input type="radio"/>	<input type="radio"/>	
26. The amount of effort to succeed in this course was:	<input type="radio"/>	<input type="radio"/>	<input type="radio"/>	
27. Your involvement in this course (doing assignments, attending classes, etc.) was:	<input type="radio"/>	<input type="radio"/>	<input type="radio"/>	
28. On average, how many hours per week have you spent on this course, including attending classes, doing readings, reviewing notes, writing papers and any other course related work?	<input type="radio"/> Under 2 <input type="radio"/> 2 - 3 <input type="radio"/> 4 - 5	<input type="radio"/> 6 - 7 <input type="radio"/> 8 - 9 <input type="radio"/> 10 - 11	<input type="radio"/> 12 - 13 <input type="radio"/> 14 - 15 <input type="radio"/> 16 - 17	<input type="radio"/> 18 - 19 <input type="radio"/> 20 - 21 <input type="radio"/> 22 or more
29. From the total average hours above, how many do you consider were valuable in advancing your education?	<input type="radio"/> Under 2 <input type="radio"/> 2 - 3 <input type="radio"/> 4 - 5	<input type="radio"/> 6 - 7 <input type="radio"/> 8 - 9 <input type="radio"/> 10 - 11	<input type="radio"/> 12 - 13 <input type="radio"/> 14 - 15 <input type="radio"/> 16 - 17	<input type="radio"/> 18 - 19 <input type="radio"/> 20 - 21 <input type="radio"/> 22 or more
30. What grade do you expect in this course?	<input type="radio"/> A (3.9-4.0) <input type="radio"/> A- (3.5-3.8) <input type="radio"/> B+ (3.2-3.4)	<input type="radio"/> B (2.9-3.1) <input type="radio"/> B- (2.5-2.8) <input type="radio"/> C+ (2.2-2.4)	<input type="radio"/> C (1.9-2.1) <input type="radio"/> C- (1.5-1.8) <input type="radio"/> D+ (1.2-1.4)	<input type="radio"/> D (0.9-1.1) <input type="radio"/> D- (0.7-0.8) <input type="radio"/> E (0.0)
31. In regard to your academic program, is this course <u>best</u> described as:	<input type="radio"/> In your major? <input type="radio"/> In your minor?	<input type="radio"/> A distribution requirement? <input type="radio"/> A program requirement?	<input type="radio"/> An elective? <input type="radio"/> Other?	

# Instructional Assessment System

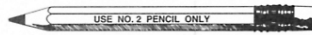

Fill in bubbles darkly and completely.  
Erase errors cleanly.

FORM <b>I</b>
------------------

Instructor \_\_\_\_\_ Course \_\_\_\_\_ Section \_\_\_\_\_ Date \_\_\_\_\_

Completion of this questionnaire is voluntary. You are free to leave some or all questions unanswered.

- |  | Excel-<br>lent        | Very<br>Good          | Good                  | Fair                  | Poor                  | Very<br>Poor          |
|--|-----------------------|-----------------------|-----------------------|-----------------------|-----------------------|-----------------------|
| 1. The distance learning course as a whole was:                              | <input type="radio"/> | <input type="radio"/> | <input type="radio"/> | <input type="radio"/> | <input type="radio"/> | <input type="radio"/> |
| 2. The course content was:   | <input type="radio"/> | <input type="radio"/> | <input type="radio"/> | <input type="radio"/> | <input type="radio"/> | <input type="radio"/> |
| 3. The instructor's contribution to the course was:                          | <input type="radio"/> | <input type="radio"/> | <input type="radio"/> | <input type="radio"/> | <input type="radio"/> | <input type="radio"/> |
| 4. The effectiveness of the distance learning format was:                    | <input type="radio"/> | <input type="radio"/> | <input type="radio"/> | <input type="radio"/> | <input type="radio"/> | <input type="radio"/> |
| 5. The helpfulness of the distance learning staff overall was:               | <input type="radio"/> | <input type="radio"/> | <input type="radio"/> | <input type="radio"/> | <input type="radio"/> | <input type="radio"/> |
| 6. Student confidence in instructor's knowledge was:                         | <input type="radio"/> | <input type="radio"/> | <input type="radio"/> | <input type="radio"/> | <input type="radio"/> | <input type="radio"/> |
| 7. Timeliness of instructor response to assignments was:                     | <input type="radio"/> | <input type="radio"/> | <input type="radio"/> | <input type="radio"/> | <input type="radio"/> | <input type="radio"/> |
| 8. Quality/helpfulness of instructor feedback was:                           | <input type="radio"/> | <input type="radio"/> | <input type="radio"/> | <input type="radio"/> | <input type="radio"/> | <input type="radio"/> |
| 9. Tailoring of instruction to varying student skill levels was:             | <input type="radio"/> | <input type="radio"/> | <input type="radio"/> | <input type="radio"/> | <input type="radio"/> | <input type="radio"/> |
| 10. Clarity of course objectives was:  | <input type="radio"/> | <input type="radio"/> | <input type="radio"/> | <input type="radio"/> | <input type="radio"/> | <input type="radio"/> |
| 11. The organization of the study guide was:                                 | <input type="radio"/> | <input type="radio"/> | <input type="radio"/> | <input type="radio"/> | <input type="radio"/> | <input type="radio"/> |
| 12. Content of the study guide was:  | <input type="radio"/> | <input type="radio"/> | <input type="radio"/> | <input type="radio"/> | <input type="radio"/> | <input type="radio"/> |
| 13. Relevance of textbook for self-study was:                                | <input type="radio"/> | <input type="radio"/> | <input type="radio"/> | <input type="radio"/> | <input type="radio"/> | <input type="radio"/> |
| 14. Usefulness of reading assignments in understanding course content was:   | <input type="radio"/> | <input type="radio"/> | <input type="radio"/> | <input type="radio"/> | <input type="radio"/> | <input type="radio"/> |
| 15. Usefulness of written assignments in understanding course content was:   | <input type="radio"/> | <input type="radio"/> | <input type="radio"/> | <input type="radio"/> | <input type="radio"/> | <input type="radio"/> |
| 16. Usefulness of videotapes in understanding course content was:            | <input type="radio"/> | <input type="radio"/> | <input type="radio"/> | <input type="radio"/> | <input type="radio"/> | <input type="radio"/> |
| 17. Usefulness of computer (on-line) resources in understanding content was: | <input type="radio"/> | <input type="radio"/> | <input type="radio"/> | <input type="radio"/> | <input type="radio"/> | <input type="radio"/> |
| 18. Usefulness of audio tapes in understanding course content was:           | <input type="radio"/> | <input type="radio"/> | <input type="radio"/> | <input type="radio"/> | <input type="radio"/> | <input type="radio"/> |
| 19. Relevance and usefulness of course content were:                         | <input type="radio"/> | <input type="radio"/> | <input type="radio"/> | <input type="radio"/> | <input type="radio"/> | <input type="radio"/> |
| 20. Evaluative and grading techniques (test, papers, projects, etc.) were:   | <input type="radio"/> | <input type="radio"/> | <input type="radio"/> | <input type="radio"/> | <input type="radio"/> | <input type="radio"/> |
| 21. Reasonableness of assigned work was:                                     | <input type="radio"/> | <input type="radio"/> | <input type="radio"/> | <input type="radio"/> | <input type="radio"/> | <input type="radio"/> |
| 22. Clarity of student responsibilities and requirements was:                | <input type="radio"/> | <input type="radio"/> | <input type="radio"/> | <input type="radio"/> | <input type="radio"/> | <input type="radio"/> |

**Relative to other college courses you have taken:**

- |  | Much<br>Higher  | Average   | Much<br>Lower   |  |   |
|--|---|---|---|--|---|
| 23. Do you expect your grade in this course to be:   | <input type="radio"/>   | <input type="radio"/>   | <input type="radio"/>   |  |   |
| 24. The intellectual challenge presented was:  | <input type="radio"/>   | <input type="radio"/>   | <input type="radio"/>   |  |   |
| 25. The amount of effort you put into this course was:   | <input type="radio"/>   | <input type="radio"/>   | <input type="radio"/>   |  |   |
| 26. The amount of effort to succeed in this course was:  | <input type="radio"/>   | <input type="radio"/>   | <input type="radio"/>   |  |   |
| 27. Your involvement in this course (doing assignments, attending classes, etc.) was:  | <input type="radio"/>   | <input type="radio"/>   | <input type="radio"/>   |  |   |
| 28. On average, how many hours per week have you spent on this course, including attending classes, doing readings, reviewing notes, writing papers and any other course related work? | <input type="radio"/> Under 2<br><input type="radio"/> 2 - 3<br><input type="radio"/> 4 - 5                   | <input type="radio"/> 6 - 7<br><input type="radio"/> 8 - 9<br><input type="radio"/> 10 - 11                   | <input type="radio"/> 12 - 13<br><input type="radio"/> 14 - 15<br><input type="radio"/> 16 - 17               | <input type="radio"/> 18 - 19<br><input type="radio"/> 20 - 21<br><input type="radio"/> 22 or more       |   |
| 29. From the total average hours above, how many do you consider were valuable in advancing your education?  | <input type="radio"/> Under 2<br><input type="radio"/> 2 - 3<br><input type="radio"/> 4 - 5                   | <input type="radio"/> 6 - 7<br><input type="radio"/> 8 - 9<br><input type="radio"/> 10 - 11                   | <input type="radio"/> 12 - 13<br><input type="radio"/> 14 - 15<br><input type="radio"/> 16 - 17               | <input type="radio"/> 18 - 19<br><input type="radio"/> 20 - 21<br><input type="radio"/> 22 or more       |   |
| 30. What grade do you expect in this course?   | <input type="radio"/> A (3.9-4.0)<br><input type="radio"/> A- (3.5-3.8)<br><input type="radio"/> B+ (3.2-3.4) | <input type="radio"/> B (2.9-3.1)<br><input type="radio"/> B- (2.5-2.8)<br><input type="radio"/> C+ (2.2-2.4) | <input type="radio"/> C (1.9-2.1)<br><input type="radio"/> C- (1.5-1.8)<br><input type="radio"/> D+ (1.2-1.4) | <input type="radio"/> D (0.9-1.1)<br><input type="radio"/> D- (0.7-0.8)<br><input type="radio"/> E (0.0) | <input type="radio"/> Pass<br><input type="radio"/> Credit<br><input type="radio"/> No Credit |
| 31. In regard to your academic program, is this course <u>best</u> described as:   | <input type="radio"/> In your major?<br><input type="radio"/> In your minor?                                  | <input type="radio"/> A distribution requirement?<br><input type="radio"/> A program requirement?             | <input type="radio"/> An elective?<br><input type="radio"/> Other?  |  |   |

# Instructional Assessment System

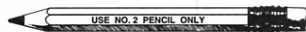

Fill in bubbles darkly and completely.  
Erase errors cleanly.

FORM

J

Instructor \_\_\_\_\_ Course \_\_\_\_\_ Section \_\_\_\_\_

Clinical Site (if appropriate) \_\_\_\_\_ Date \_\_\_\_\_

Completion of this questionnaire is voluntary. You are free to leave some or all questions unanswered.

	Excel- lent	Very Good	Good	Fair	Poor	Very Poor
1. The rotation/studio as a whole was:	<input type="radio"/>	<input type="radio"/>	<input type="radio"/>	<input type="radio"/>	<input type="radio"/>	<input type="radio"/>
2. The procedures/skills taught were:	<input type="radio"/>	<input type="radio"/>	<input type="radio"/>	<input type="radio"/>	<input type="radio"/>	<input type="radio"/>
3. The instructor's contribution to the rotation/studio was:	<input type="radio"/>	<input type="radio"/>	<input type="radio"/>	<input type="radio"/>	<input type="radio"/>	<input type="radio"/>
4. The instructor's effectiveness in teaching was:	<input type="radio"/>	<input type="radio"/>	<input type="radio"/>	<input type="radio"/>	<input type="radio"/>	<input type="radio"/>

**Rate your instructor on each of the following:**

5. Knowledgeable and analytical	<input type="radio"/>	<input type="radio"/>	<input type="radio"/>	<input type="radio"/>	<input type="radio"/>	<input type="radio"/>
6. Clear and organized	<input type="radio"/>	<input type="radio"/>	<input type="radio"/>	<input type="radio"/>	<input type="radio"/>	<input type="radio"/>
7. Enthusiastic and stimulating	<input type="radio"/>	<input type="radio"/>	<input type="radio"/>	<input type="radio"/>	<input type="radio"/>	<input type="radio"/>
8. Challenging	<input type="radio"/>	<input type="radio"/>	<input type="radio"/>	<input type="radio"/>	<input type="radio"/>	<input type="radio"/>
9. Established rapport	<input type="radio"/>	<input type="radio"/>	<input type="radio"/>	<input type="radio"/>	<input type="radio"/>	<input type="radio"/>
10. Actively involved me in learning experiences	<input type="radio"/>	<input type="radio"/>	<input type="radio"/>	<input type="radio"/>	<input type="radio"/>	<input type="radio"/>
11. Provided direction and feedback	<input type="radio"/>	<input type="radio"/>	<input type="radio"/>	<input type="radio"/>	<input type="radio"/>	<input type="radio"/>
12. Demonstrated clinical/professional skills and procedures	<input type="radio"/>	<input type="radio"/>	<input type="radio"/>	<input type="radio"/>	<input type="radio"/>	<input type="radio"/>
13. Accessible	<input type="radio"/>	<input type="radio"/>	<input type="radio"/>	<input type="radio"/>	<input type="radio"/>	<input type="radio"/>

14. Your involvement with the instructor:       Extensive       Considerable       Moderate       Slight

15. On average, how many hours per week have you spent on this rotation/studio?  
 Under 2     6 - 7     12 - 13     18 - 19  
 2 - 3     8 - 9     14 - 15     20 - 21  
 4 - 5     10 - 11     16 - 17     22 or more

16. From the total average hours above, how many do you consider were valuable in advancing your education?  
 Under 2     6 - 7     12 - 13     18 - 19  
 2 - 3     8 - 9     14 - 15     20 - 21  
 4 - 5     10 - 11     16 - 17     22 or more

17. Year in program:       First       Second       Third       Fourth or more

18. Your program (choose one):  
 Baccalaureate       Professional       Other  
 Masters       Resident  
 PhD       Postdoctoral fellow



# Instructional Assessment System

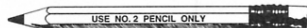

Fill in bubbles darkly and completely.  
Erase errors cleanly.

FORM



Instructor \_\_\_\_\_ Course \_\_\_\_\_ Section \_\_\_\_\_ Date \_\_\_\_\_

Completion of this questionnaire is voluntary. You are free to leave some or all questions unanswered.

	Excel- lent	Very Good	Good	Fair	Poor	Very Poor
1. The course as a whole was:	<input type="radio"/>	<input type="radio"/>	<input type="radio"/>	<input type="radio"/>	<input type="radio"/>	<input type="radio"/>
2. The course content was:	<input type="radio"/>	<input type="radio"/>	<input type="radio"/>	<input type="radio"/>	<input type="radio"/>	<input type="radio"/>
3. The instructor's contribution to the course was:	<input type="radio"/>	<input type="radio"/>	<input type="radio"/>	<input type="radio"/>	<input type="radio"/>	<input type="radio"/>
4. The instructor's effectiveness in teaching the subject matter was:	<input type="radio"/>	<input type="radio"/>	<input type="radio"/>	<input type="radio"/>	<input type="radio"/>	<input type="radio"/>

How frequently was each of the following a true description of this course?

	Always	Often	Sometimes	About Half	Rarely	Never
5. The instructor gave very clear explanations.	<input type="radio"/>	<input type="radio"/>	<input type="radio"/>	<input type="radio"/>	<input type="radio"/>	<input type="radio"/>
6. The instructor successfully rephrased explanations to clear up confusion.	<input type="radio"/>	<input type="radio"/>	<input type="radio"/>	<input type="radio"/>	<input type="radio"/>	<input type="radio"/>
7. Class sessions were interesting and engaging.	<input type="radio"/>	<input type="radio"/>	<input type="radio"/>	<input type="radio"/>	<input type="radio"/>	<input type="radio"/>
8. Class sessions were well organized.	<input type="radio"/>	<input type="radio"/>	<input type="radio"/>	<input type="radio"/>	<input type="radio"/>	<input type="radio"/>
9. Student participation was encouraged.	<input type="radio"/>	<input type="radio"/>	<input type="radio"/>	<input type="radio"/>	<input type="radio"/>	<input type="radio"/>
10. Students were aware of what was expected of them.	<input type="radio"/>	<input type="radio"/>	<input type="radio"/>	<input type="radio"/>	<input type="radio"/>	<input type="radio"/>
11. Extra help was readily available.	<input type="radio"/>	<input type="radio"/>	<input type="radio"/>	<input type="radio"/>	<input type="radio"/>	<input type="radio"/>
12. Assigned readings and other out-of-class work were valuable.	<input type="radio"/>	<input type="radio"/>	<input type="radio"/>	<input type="radio"/>	<input type="radio"/>	<input type="radio"/>
13. Grades were assigned fairly.	<input type="radio"/>	<input type="radio"/>	<input type="radio"/>	<input type="radio"/>	<input type="radio"/>	<input type="radio"/>
14. Meaningful feedback on tests and other work was provided.	<input type="radio"/>	<input type="radio"/>	<input type="radio"/>	<input type="radio"/>	<input type="radio"/>	<input type="radio"/>
15. Evaluation of student performance was related to important course goals.	<input type="radio"/>	<input type="radio"/>	<input type="radio"/>	<input type="radio"/>	<input type="radio"/>	<input type="radio"/>

Relative to other college courses you have taken, how would you describe your progress in this course with regard to:

	Great	Good	Average	Poor	None
16. Learning the conceptual and factual knowledge of this course.	<input type="radio"/>	<input type="radio"/>	<input type="radio"/>	<input type="radio"/>	<input type="radio"/>
17. Developing an appreciation for the field in which this course resides.	<input type="radio"/>	<input type="radio"/>	<input type="radio"/>	<input type="radio"/>	<input type="radio"/>
18. Understanding written material in this field.	<input type="radio"/>	<input type="radio"/>	<input type="radio"/>	<input type="radio"/>	<input type="radio"/>
19. Developing an ability to express yourself in writing or orally in this field.	<input type="radio"/>	<input type="radio"/>	<input type="radio"/>	<input type="radio"/>	<input type="radio"/>
20. Understanding and solving problems in this field.	<input type="radio"/>	<input type="radio"/>	<input type="radio"/>	<input type="radio"/>	<input type="radio"/>
21. Applying the course material to real world issues or to other disciplines.	<input type="radio"/>	<input type="radio"/>	<input type="radio"/>	<input type="radio"/>	<input type="radio"/>
22. General intellectual development.	<input type="radio"/>	<input type="radio"/>	<input type="radio"/>	<input type="radio"/>	<input type="radio"/>

Relative to other college courses you have taken:

	Much Higher	Higher	Average	Lower	Much Lower
23. Do you expect your grade in this course to be:	<input type="radio"/>	<input type="radio"/>	<input type="radio"/>	<input type="radio"/>	<input type="radio"/>
24. The intellectual challenge presented was:	<input type="radio"/>	<input type="radio"/>	<input type="radio"/>	<input type="radio"/>	<input type="radio"/>
25. The amount of effort you put into this course was:	<input type="radio"/>	<input type="radio"/>	<input type="radio"/>	<input type="radio"/>	<input type="radio"/>
26. The amount of effort to succeed in this course was:	<input type="radio"/>	<input type="radio"/>	<input type="radio"/>	<input type="radio"/>	<input type="radio"/>
27. Your involvement in this course (doing assignments, attending classes, etc.) was:	<input type="radio"/>	<input type="radio"/>	<input type="radio"/>	<input type="radio"/>	<input type="radio"/>

28. On average, how many hours per week have you spent on this course, including attending classes, doing readings, reviewing notes, writing papers and any other course related work?	<input type="radio"/> Under 2	<input type="radio"/> 6 - 7	<input type="radio"/> 12 - 13	<input type="radio"/> 18 - 19
	<input type="radio"/> 2 - 3	<input type="radio"/> 8 - 9	<input type="radio"/> 14 - 15	<input type="radio"/> 20 - 21
	<input type="radio"/> 4 - 5	<input type="radio"/> 10- 11	<input type="radio"/> 16 - 17	<input type="radio"/> 22 or more

29. From the total average hours above, how many do you consider were valuable in advancing your education?	<input type="radio"/> Under 2	<input type="radio"/> 6 - 7	<input type="radio"/> 12 - 13	<input type="radio"/> 18 - 19
	<input type="radio"/> 2 - 3	<input type="radio"/> 8 - 9	<input type="radio"/> 14 - 15	<input type="radio"/> 20 - 21
	<input type="radio"/> 4 - 5	<input type="radio"/> 10- 11	<input type="radio"/> 16 - 17	<input type="radio"/> 22 or more

30. What grade do you expect in this course?	<input type="radio"/> A (3.9-4.0)	<input type="radio"/> B (2.9-3.1)	<input type="radio"/> C (1.9-2.1)	<input type="radio"/> D (0.9-1.1)	<input type="radio"/> Pass
	<input type="radio"/> A- (3.5-3.8)	<input type="radio"/> B- (2.5-2.8)	<input type="radio"/> C- (1.5-1.8)	<input type="radio"/> D- (0.7-0.8)	<input type="radio"/> Credit
	<input type="radio"/> B+ (3.2-3.4)	<input type="radio"/> C+ (2.2-2.4)	<input type="radio"/> D+ (1.2-1.4)	<input type="radio"/> E (0.0)	<input type="radio"/> No Credit

31. In regard to your academic program, is this course <u>best</u> described as:	<input type="radio"/> In your major?	<input type="radio"/> A distribution requirement?	<input type="radio"/> An elective?
	<input type="radio"/> In your minor?	<input type="radio"/> A program requirement?	<input type="radio"/> Other?

## Appendix K

### Online Autocad Tutorial

**Ref:** <http://www.CADtutor.net>

#### Awards

CADTutor was awarded the **TenLinks** "Site of the Week" for the week of 2nd April 2001. The site is also listed number 1 in the top ten AutoCAD tutorial sites.

CADTutor was awarded a 2002-2003 Golden Web Award in April 2002.

7th October 2002, CADTutor gets an article in **CADALYST Newslines**.

#### **CADALYST Newslines**

News and Productivity Tips for CAD Users

10/07/02. Volume 7 No. 40

CADTutor offers more than 30 tutorials by David Watson that cover AutoCAD R14-2000i. The site also includes lessons on digital design (3ds max, Photoshop) and tips for building Web pages.

10/22/01. Volume 6 No. 43

#### CADTUTOR

The CADTutor Web site delivers free help and tutorials for AutoCAD and associated software. The AutoCAD section provides over 30 original tutorials covering various AutoCAD versions for both beginners and advanced users. The Digital Design section covers other design applications such as 3D Studio, Photoshop, Bryce, and PowerPoint. The Image Bank section provides free vector and raster images for use in your projects and tips on how best to use them.

#### User Comments

"...So why do I keep returning to your site, opposed to the other trillion or so out there? It has a magnetic appeal in it's style and simplicity, I'm certainly no expert, yet not new to the web. I've been surfing for years. Of all the sites I have ever visited, yours has to rate amongst the very best..."

Martin Lynam, UK

"Thank you for the wonderful information on your website. I have been studying AutoCAD 2000 for almost a year and I feel that I have gained more information in the 2 hours that I spent on your site than in the previous 2 months of classroom study. You definitely have the knack for presenting information in a clear and concise manner..."

Jim Martin, Canada

"I just discovered your CAD tutorial on how to manage the hybridization shared between AutoCAD and Photoshop. It is a great resource! I plan to direct my clients who will be using our products to your site and tutorial..."

So thank you very much for your hard work at clearly explaining what can be a rather difficult thing for many architects to understand well. "

Peter Aaslestad, USA

"I am an intern architect in Montreal, Canada, who just found your site searching for standalone "photoshopped" trees and wanted to comment on the beautiful, thorough clear website! A site I will return to and recommend highly!

Keep up the incredible work!"

Layla Macleod, Canada

"I have been browsing the web in search of AutoCAD tutorials, and finally I found your pages, which are wonderful. I doubt very much that someone could beat these tutorials, they are cool..."

Gilberto Brandao, USA

"...3 days ago I purchased 3D Studio MAX and with the help of your tutorial it was a breeze to learn the AutoCAD walk through. I have been using a lot of what is on offer on the net for learning this software, but no one has made it easier and been more interested in actually showing someone how to learn than you have..."

Ben Taylor, UK

CADTutor.co.uk provides learning resources and events news specific to students and professionals studying and working in the UK.

**CADTutor Tutorials** provides nearly 50 original tutorials covering various AutoCAD versions, 3D Studio, Adobe Photoshop and other applications.

**Student Resources** covers all the stuff that might be useful to students studying digital design in architecture, landscape and related disciplines.

**Summer Courses** provides details of professional CAD courses run during the summer break at the University of Greenwich.

New taught courses announced for Easter 2003 at the University of Greenwich, Avery Hill Campus.

A major new tutorial, AutoCAD to Photoshop, covers the oft asked question "How do I move AutoCAD drawings to Photoshop?". This comprehensive tutorial covers all aspects of the process. It is accompanied by another new tutorial, Setting up a PostScript Plotter.

### About CADTutor

CADTutor is always evolving to bring you the best up-to-date information and tutorials on your favorite applications. CADTutor is used by students and professionals the world over. Whether you are a first-time user of AutoCAD or a seasoned digital designer looking to improve your skills, CADTutor provides the resources to help and a large community of users just like you.



<http://www.tekguide.net/features/2004,07,19.shtml>



There are a total of five sections in the **CadTutor** site, AutoCad, Digital Design, Web Building, Image Bank, and community. Each section is basically a tutorial for whoever is interested in CAD and graphics. The AutoCAD section provides over 40 original tutorials. Digital Design covers all other design applications, such as 3D Studio, Photoshop, Bryce and PowerPoint. Web Building covers all things related to web site design and the Image Bank provides free vector and raster images. If you are looking to learn CAD, you must check this site first.

"CADTutor delivers the best free AutoCAD tutorials on the web and a friendly AutoCAD user forum. Need to learn? You're in the right place."

TekGuide, October 2004

## Appendix L

### **AutoCAD Learning Assistance CD-ROM**

by

Autodesk Corporation, Sausalito, CA

Product: AutoCAD Learning Assistance

Provider: Autodesk, Inc. 111 McInnis Parkway, San Rafael, CA 94903

Media Type: Independent CD-ROM Tutorial and reference

#### Description

##### AutoCAD Learning Assistance™ (ALA)

AutoCAD Learning Assistance, the tutorial-based, multimedia learning tool, includes lessons and concepts material for many new AutoCAD 2000 features. ALA helps both the novice and veteran AutoCAD user to take full advantage of new features such as object tracking, the Layer Properties Manager, the Object Properties dialog, and the many other connectivity and productivity enhancements introduced in AutoCAD 2000 software.

#### Referentia Systems Incorporated

AutoCAD Learning Assistance Wins Editor's Choice Award

#### AutoCAD Learning Assistance

AutoCAD Learning Assistance is a comprehensive multimedia learning tool to help novice users master AutoCAD. With step-by-step animated tutorials, Web-like linking of related drafting concepts and just-in-time learning exercises that introduce or reinforce design concepts at the very time they are needed, AutoCAD Learning Assistance strikes us as a long-awaited breakthrough product. CAD managers and trainers will doubtless use the software to prime students with self-paced assignments before more formal classes. And those who have an insatiable drive to explore all the nooks and crannies of AutoCAD now have a multimedia interface that makes exploration just plain fun. This

product is infotainment that can potentially impact the bottom line by helping users hone the skills that effect day-to-day productivity.

Referentia is a registered trademark of Referentia Systems Incorporated. Product and company names herein may be the trademarks of their respective owners.

## CADENCE

### **Andrew G. Roe**

*Andrew G. Roe is a registered civil engineer and president of AGR Associates, Inc. He also serves on the CADENCE Editorial Advisory Board, and is the author of Using Visual Basic with AutoCAD, published by Autodesk Press. He can be reached at [agroe@compuserve.com](mailto:agroe@compuserve.com).*

### ***New Technology Drives AutoCAD Training Techniques***

With AutoCAD 2000, AutoCAD Learning Assistance debuts a new "open-learning-environment" architecture that can funnel content from a Web server or intranet to a trainee's desktop. But don't count out face-to-face learning just yet-it more than holds its own in today's techno-savvy training curricula.

As CAD software has grown more complex, so has the task of training CAD users. With expanding feature lists, high productivity expectations from employers and growing use of electronic data exchange, most CAD users are doing more than basic drafting. The broadening demands of the digital age mean CAD users have more and more tools at their fingertips, but they also have more to learn. And often they are asked to learn at breakneck speed.

Fortunately for today's CAD user, the double-edged sword of technology also offers new alternatives for training and education. With the Internet gaining acceptance for everything from general correspondence to final product delivery, many computer professionals are finding the World Wide Web a convenient educational platform. Information can be delivered in a variety of formats, and new real-time conferencing tools can allow interaction to occur much like in a classroom setting. Self-paced CD-ROM training programs are also maturing, as vendors offer more intuitive and versatile packages.

"The use of technology-based training is on an upswing," says Mark Van Buren, director of research for the American Society for Training and Development ([www.astd.org](http://www.astd.org)), an Alexandria, VA-based association that tracks workplace learning and performance. He says nearly 20 percent of all training is based on some form of electronic technology, such as CD-ROM, the Internet, cable television or satellite links. In 1996, that figure was between 8 and 9 percent.

Van Buren says convenience, cost savings and improved multimedia technology have led companies to adopt technology-based learning. Many organizations are using Web- or CD-based learning systems to minimize travel expenses and employee down time. But even with the flashy new tools, some industry professionals prefer more traditional learning channels such as instructor-led classes and training videos. "There's still nothing like seeing a person face-to-face," says Van Buren, predicting that classroom training will

be supplemented-but not replaced-by the newer training tools.

### Open-Ended Learning

Software vendors such as Autodesk ([www.autodesk.com](http://www.autodesk.com)) apparently see a bright future for technology-based learning. With AutoCAD 2000, the company released a modified version of its Autodesk Learning Assistance system that allows end users to add their own content to that provided by Autodesk. After installing the system using the ALA CD-ROM that ships with AutoCAD 2000, users can arrange information from text, graphic or animation files and display it on screen just like the Autodesk material shown in Figure 1.

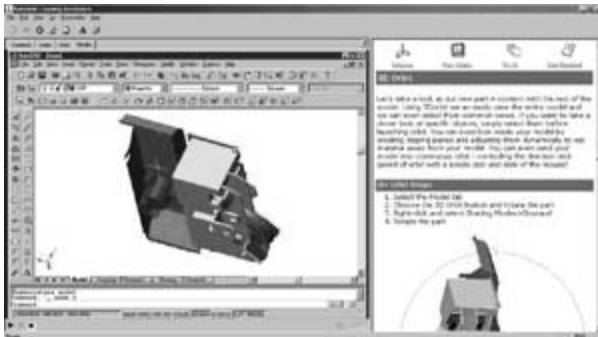

**Figure 1. Autodesk Learning Assistance provides training content in a multimedia environment.**

Possible uses of the open-ended system include placing company drafting standards or suggested procedures for certain tasks in files accessible to all CAD users in a firm. Tips and tricks for using AutoCAD and third-party software might also be included. The added topics are displayed in the menu along the left side of the screen, as shown in Figure 2.

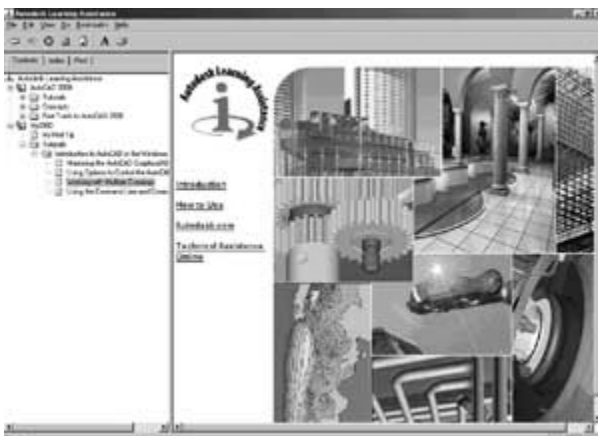

**Figure 2. Users can add their own topics to Autodesk Learning Assistance.**

The new ALA system "is a vehicle that handles content from many sources," says Jimm Meloy, Autodesk's worldwide director of Learning and Training. "The customer doesn't

know where it's coming from" because the interface is seamless. In addition to displaying user-created screens, the system includes a "Try It" link that allows a user to launch an application and try out a help technique live, with the help content still displayed on the screen. While this feature is primarily intended for users to launch AutoCAD, it can also be used to launch any other application, such as Microsoft Excel or Word, and demonstrate concepts covered in custom help files.



Source (October 2004):

<http://www.cadresource.com/r2000/4%20page%20summary%20fax.htm>

#### Ease Your Transition

AutoCAD 2000 supplies vital learning assistance and utilities to help smooth your transition from an earlier version of AutoCAD software.

- AutoCAD Learning Assistance™, an award-winning interactive training tool, helps you learn<sup>3/4</sup> and find more ways to use<sup>3/4</sup> the software's new features and enhancements.
- AutoCAD Support Assistance, which answers commonly asked questions directly from your desktop, can be updated each quarter from the Autodesk website.
- AutoCAD Migration Assistance contains numerous timesaving tools for migrating your custom applications, routines, and more.

## Learning from the Inside

*Arnie Williams*

*CADENCE Channel*

*November, 2004*

Criticized for many years for the difficulty of AutoCAD and the enormous learning curve new users faced after spending several thousand dollars to purchase the program,



Autodesk took solid steps to make AutoCAD easier to master last year when the company introduced Inside Track. Modeled after Encarta, the successful multimedia encyclopedia, Inside Track sported a searchable glossary, movie demos of drawing techniques, a general concepts to specific drawing task palette of choices, and narrated step-by-step tutorials. The relatively inexpensive CD was a hit among both day-to-day users and CAD managers who could assign users exercises on the CD before setting down with trainees to cover similar techniques for in-house courses.

With the launch of AutoCAD Release 14 in May, Autodesk brought a redesigned Inside Track inside AutoCAD and called it AutoCAD Learning Assistance.

### A Movie Startup

Installing AutoCAD Learning Assistance is easy. You merely insert the CD in your PC's drive, and the install Wizard takes over with standard Windows dialog boxes to take you through all the necessary steps. Then you're greeted with an introductory movie that gives you a sampling of some of the features provided. One of the technological improvements over the early Inside Track CDs is that AutoCAD Learning Assistance sports an Internet Explorer interface and is, in fact, designed to link you to the Autodesk Web site for additional support.

### Concepts

Learning Assistance is divided into three sections: Tutorials, Fast Answers and Concepts. Let's take the last section first. Clicking on Concepts takes you to a page designed much like "frames" on a Web site. In the left frame appear terms such as 3D Design, Boolean Operations, Coordinate Entry Method, Object Snaps, Raster Files and so on. The terms are alphabetized and cover the main terms an AutoCAD user needs to know. This is a great place for the novice to start.

Clicking on a term in the left frame brings up its definition in the right frame. If you're just looking for a reminder of what a term means, this is a quick way to refresh your memory. But each definition is headed by a filmstrip icon titled "play animation" and herein lies one of the key strengths of the program. You can not only read the meaning of a term, but see the operation described in action. The narrated animations are short, but visually illustrate what a term such as Boolean Operations, for example, really means.

### Fast Answers

The Fast Answers section also uses the "frames" method of organization, this time dividing your screen into three areas. A left section lists broad categories of Windows Explorer-type folders, such as Drawing With Precision, Using Blocks, Attributes, and External References and so on. The right two frames take the Web-like design even further, allowing you to enter the term you want to search for in the top frame and displaying the results of the search in the bottom frame. Clicking on any selection brings

up explanations, short animations, and hot-linked terms that transport you to related concepts.

Fast Answers is meant to be just that--a just-in-time knowledge bank where you can go when you've got a question and little time. Let's say you're stumped during a project. You enter your question in the search area, read about a technique, perhaps play an animation, and then back to work. But this area also bears some exploring when you have the time.

## Tutorials

The heart of AutoCAD Learning Assistance is three main tutorials: the first covers the Windows environment and guides you through techniques to use AutoCAD and Windows more efficiently. The second tutorial concentrates on how to draw more efficiently by helping you hone basic AutoCAD skills and the third tutorial section covers collaboration techniques, including ways to use the Internet to share drawings and work with raster files inside of AutoCAD.

The tutorials are designed for easy use: click on a technique you want help with in the left frame, and the tutorial lesson is displayed in the right frame. First, watch a narrated animation of the technique performed for you. Then you can read through the steps that were followed in the animation to perform the technique. And finally, a learn-by-doing option: you click on the "try it" icon, and AutoCAD is launched for you. The drawing area is reduced and the tutorial steps are placed in a frame beside the drawing area so that you can follow the steps and perform the technique yourself.

## Learning from the Inside

CAD managers and AutoCAD novices will probably be the greatest fans of AutoCAD Learning Assistance. But the program is just plain fun to explore for any level AutoCAD user. It's primary strengths are the number of options it provides. If you just want the quick glimpse of a written definition and then want to be on your way, it's like having an extended Help file at your service. If you're a visual learner, almost every technique accomplished users encounter on a project is illustrated here with brief animations. And if you just like to explore and learn by discovery, there's plenty of that for you, as well.

## Sample Layout of the Tutorial Interface

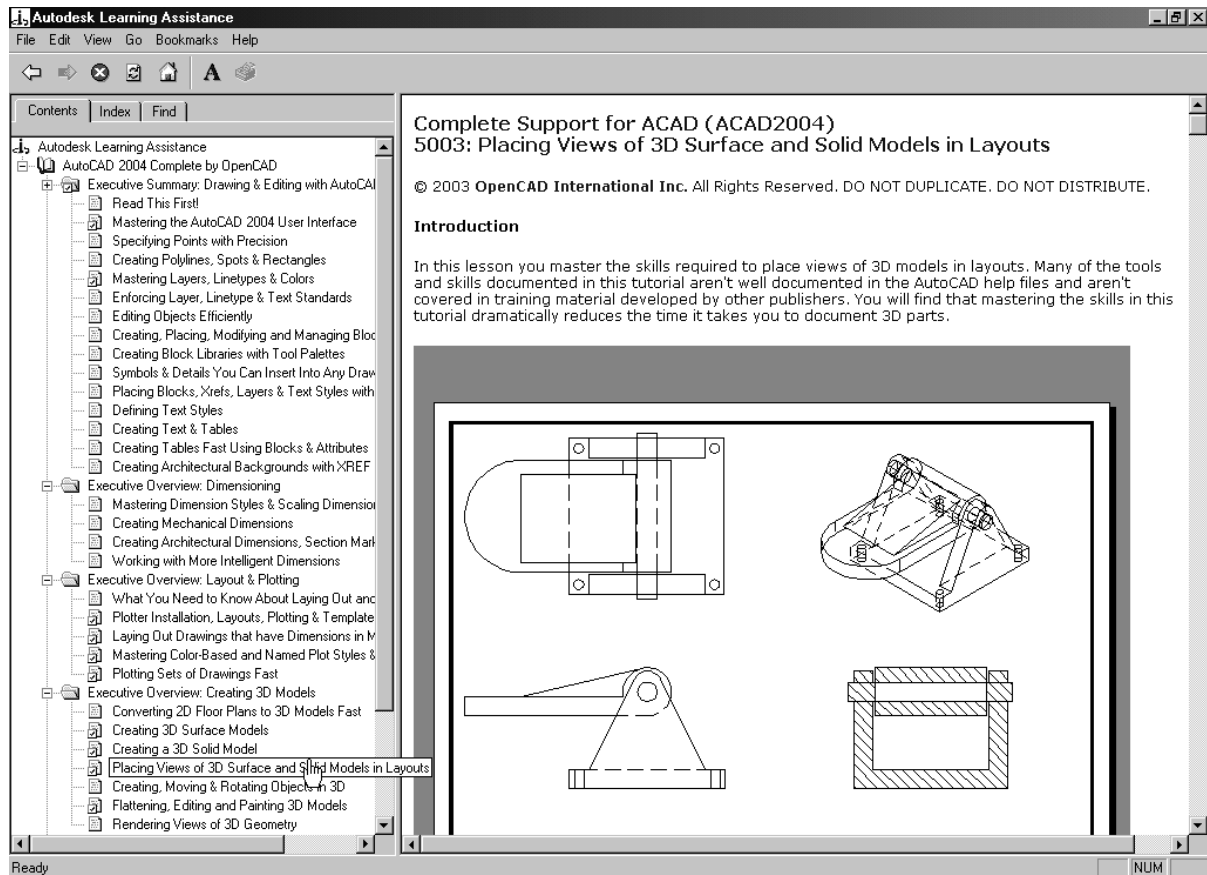

### List of General Topics Covered on the CD-ROM:

- Mastering the AutoCAD User Interface
- Precision Drawing Commands including Object Tracking, Editing Objects
- Creating and Modifying Layers
- Creating and Editing Blocked Symbols
- Using Design Center to Manage Drawing Data
- Working with External References (Xrefs)
- In-Place Editing of Blocks and External References
- Working with Text and Text Styles
- Architectural and Mechanical Dimensioning
- Creating and Maintaining Dimension Styles
- Using Layouts to Plot Multiple Drawings
- Creating Scaled Drawings
- Plotting Drawings
- Installing Plotters
- Working with Page Setup
- Plot Styles & Plot Style Tables

- Understanding Named Plot Style Tables
- Working with Layers and Layer States
- Publishing Drawings on Web Pages
- Using Partial Open and Partial Load to Work with Large Drawing Files
- Creating and Transferring Files using the Internet
- Creating Block Libraries Fast
- Creating and Viewing Electronic Plots,
- Creating 3D Architectural Models with Hollow Walls
- Creating 3D Architectural Models with Solid Walls
- Creating 3D Architectural Models from Elevations
- Surface Modeling for Mechanical Applications
- Creating, Editing and Viewing Mechanical Solid Models
- Creating Presentation Graphics with VIZ and AutoCAD
- Moving, Copying and Rotating Objects in 3D
- Creating Standard Views of Solid Parts and Assemblies
- Working with Faces and User Coordinate Systems
- Exporting, Editing and Painting 2D Views of 3D Models
- Modifying AutoCAD's User Interface
- Creating Custom Toolbars
- Flyouts and Shortcuts
- Working with Custom Menus
- Introduction to AutoLISP
- Creating Commands with AutoLISP

## Appendix M

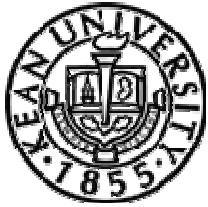

**Kean University**  
**1000 Morris Avenue**  
**Union, New Jersey 07083**  
**(908) 737-5326**

**PLEASE POST AT YOUR COMPANY NEWS BOARD**

**Attention all**  
**Manufacturing / Technical /**  
**Construction/Architectural employees**

---

Free professional training available as part of the special ACTC program for all employees interested in learning Autocad Level I. The training will be free of charge to all applicants.

Please be advised that the number of applicants is limited.

RSVP your registration before Friday, Jan.14, 2005

To register please contact  
Professor James A. Sinclair, Director of ACTC Center or Mrs. Elaine  
Smalley, Technology Dept. Secretary  
At (908) 737-3517 or (908) 737-3520

## Appendix N

### Content Validity of the Achievement Examination

The Content Validity of the achievement test was established by the panel of three experts. In Appendix C there is a list of objectives that the panel of experts used to measure the quality of the Achievement examination (criterion validity). Each question on the test was evaluated by each expert against the specific objective. The appendix C provides the list of objectives and the Appendix D provides the rating forms that were used to measure the questions against the specific objectives. There were many changes during the initial process both to the test and the objective list. The test went through a number of modifications before it was used first during the pilot, and in the final experiment. The rating form in Appendix D were broken into 3 parts (questions 1-25, 26-50. 51-75). There were 8 objectives in each module, and 25 rating components, each rated on the Likert scale. The entire content of the Achievement test was scrutinized and rated. The inter reliability was established by analyzing the mean statistics and a variance of results among the raters. Furthermore, the test results during the pilot studies and the experiment were randomly split in two halves and analyzed for consistency and unanimously found reliable within a statistically acceptable range ( $\alpha = 0.87$ ).

#### *Actual Validity Data Results:*

Professor Marvin Sarapin, Coordinator Dept. of Technology, Kean University	$\alpha = 0.89$
Professor Timothy Riegle, Coordinator Design Department, Kean University	$\alpha = 0.86$
Professor Alexander Tsygutkin, Faculty, Dept. of Technology, Kean University	$\alpha = 0.85$
Total mean results of al raters:	$\alpha = 0.866$

### Reference List

- Abbey, B. (2000). *Instructional and Cognitive Impacts of Web-Based Education*. Hershey, PA: Idea Group Publishing.
- Abramov, L. & Martkovich, N. (2002). Making Teachers Feel Contented with Online Courses. *USDLA Journal*, 16(2), February, 1-16.
- Advanced Systems Technology, Inc. (AST). (1999). *Development of Computer-Based Training for Law Enforcement*. Lawton, OK: Advanced Systems Technology Publications.
- Aldrich, C. (2005). *Learning by Doing: A Comprehensive Guide to Simulations, Computer Games, and Pedagogy in e-Learning and Other Educational Experiences*. Indianapolis, IN: Wiley Publishing Jossey-Bass.
- Allen, M., Bourhis, J., Burrell, N., & Mabry, E., (2002). Comparing student satisfaction with distance education to traditional classrooms in higher education: A meta-analysis. *The American Journal of Distance Education*, 16(2), 83-97.
- Anderson, L.P., Banks, S.R., & Leary, P.A. (2002). The effect of interactive television courses on student satisfaction. *Journal of Education for Business*, 7, 164-168.
- Aragon, S. R. (2003). *Facilitating Learning in Online Environments: New Directions for Adult and Continuing Education*. Indianapolis, IN: Wiley Publishing.
- Aragon, S. R., Johnson, S., Palma-Rivas, N., & Shaik, N. (2000). Comparative Analysis of Online vs. Face-to-Face Instruction. *Champaign, IL: University of Illinois at Urbana-Champaign. Department of Human Resource Education Publications*.
- Arbaugh, J.B. (2000). Virtual Classroom vs. Physical Classroom: An Exploratory Study of Class Discussion Patterns and Student Learning in an Asynchronous, Internet-based MBA Course. *Journal of Management Education*, 24(2), 213-233
- Arsham, H. (2002). Impact of the Internet on Learning and Teaching. *USDLA Journal*, 16(3), 1-16.
- Ayers, J. (1972). *Sensory Integration and the Child*. Los Angeles, CA: Western Psychological Services.
- Bailey, R.N. (1996). *Human performance engineering: Designing high Quality Professional User Interfaces for Computer Products, Applications, and Systems*. Saddle River, NJ: Prentice Hall.
- Bahrck, H.P., & L.K. Hall. (1991). Lifetime Maintenance of High School Mathematics

- Content. *Journal of Experimental Psychology*, 120, 20-33.
- Banathy, B. (1994). *Designing Educational Systems: Creating Our Future In a Changing World*. Englewood Cliffs, NJ: Educational Technology Publications.
- Barnett, J. (1994) *Learning styles*. South Carolina Department of Education.
- Barr, R. E., & Juricic, D., (1998). Development of a Modern Curriculum for Engineering Design Graphics. *Engineering Education*, 81 (1) 26-29.
- Bastiaens, T.J. & Martens, R.L. (2000). *Instructional and Cognitive Impacts of Web-Based education*. Hershey, PA: Idea Group Publishing.
- Beard, L.A., & Harper, C. (2002). Student perceptions of online versus on campus instruction. *Education*, 122, 658-663.
- Belanger, F. (2000). *Evaluation and Implementation of Distance Learning: Technologies, Tools, and Techniques*. Hershey, PA: Idea Group Publications.
- Belanger, K., & Strom, L. (1999). *Second shift: Teaching writing to working adults*. Portsmouth, NH: Boynton/Cook.
- Bender, D.M., Wood, B.J. & Vredevoogd, J.D. (2004). Teaching Time: Distance Education Versus Classroom Instruction. *American Journal of Distance Education*, 18(2), 103-114.
- Berge, Z.L. (2002). Active, interactive, and reflective elearning. *Quarterly Review of Distance Education*, 3, 181-190.
- Bloom, F., Lazerson, A., & Hofstadter, L. (1988) *Brain, Mind and Behavior*, 2<sup>nd</sup> edition. New York, NY: W.H. Freeman & Co.
- Bobinski, D. (2002) Learning and the Brain. *Leadership Development*. Retrieved March 8, 2006 from the World Wide Web:  
<http://www.leadershipanswers.com/ArticleDetails.asp?ID=3>
- Boone, E.J., Jones, J. & Safrit, R.D., (2002). *Developing Programs in Adult Education: A Conceptual Programming Model*. Long Grove, IL: Waveland Press.
- Brandt, D. S. (1996, February). Teaching the net: Innovative Techniques in Internet Training. *Washington, DC: Paper presented at the 11<sup>th</sup> Annual Computers in Business Conference*.
- Briggs, K., & Myers, I. (1991). *Myers-Briggs Type Indicator*. Palo Alto, CA: Consulting Psychologists Press.



- Bruce, V. & Green, P. (1990). *Visual Perception*. East Sussex, UK: Lawrence Erlbaum & Associates.
- Burleson, W., Ganz, A., & Harris, I. (2001). Educational Innovations in Multimedia Systems. *Journal of Engineering Education*, 90 (1), 21-31.
- Buzan, T. (1984) *Make the Most of Your Mind*. New York, NY: Linden Press/Simon & Schuster.
- Caffarella, R. (2001). *Planning Programs for Adult Learners: A Practical Guide for Educators, Trainers, and Staff Developers*, 2<sup>nd</sup> Edition. Hoboken, NJ: Jossey-Bass Publications.
- Chen, H. (2002). Interaction in distance education. Retrieved March 8, 2006, from the World Wide Web: <http://seamonkey.ed.asu.edu/~mcisaac/disted/week2/7focushc.html>
- Cranton, P. (2001). *Planning Instruction for Adult Learners*, 2<sup>nd</sup> Edition. Toronto, Ontario: Wall & Emerson Publications.
- Davis, J. (1997). *Mapping the Mind*. Secaucus, NJ: Carol Publishing Group.
- Debourgh, G. A. (1998). *Learner And Instructional Predictors Of Student Satisfaction In A Program Taught Via Interactive Video Conferencing*. Doctoral Dissertation. San Francisco, CA: University of San Francisco.
- Desberg, P., & Fisher, F. (2000). *Teaching with Technology*. 3<sup>rd</sup> Edition. Boston, MA: Allyn & Bacon - Longman Publishers.
- Driscoll, M. & Carliner, S. (2005). *Advanced Web-Based Training Strategies: Unlocking Instructionally Sound Online Learning*. Indianapolis, IN: Wiley Publishing.
- Enockson, J. (1997). *An Assessment Of An Emerging Technological Delivery For Distance Education*. Doctoral Dissertation. Flagstaff, AZ: Northern Arizona University.
- Ertmer, P.A., & Newby, T. (1996). The Expert Learner: Strategic, Self-Regulated and Reflective. *Instructional Science*, 24, 1-24.
- Florman, S. (1997). Escape From Engineering Boot Camp. *Technology Review*, 96 (1).
- Galbraith, M.W. (2003). *Adult Learning Methods: A Guide for Effective Instruction* Melbourne, FL.: Krieger Publishing Company.
- Galyan, D. (1999). Nurse Education, Hyperlearning, and a Virtual Clinic. *Research & Creative Activity*, 22 (1).
- Gay, L.R., & Airasian, P. (2000). *Educational Research*. Saddle River, NJ: Prentice Hall.

- Ghee, S. (June, 1998). The virtues of virtual products. *Mechanical Engineering*. Retrieved March 8, 2006 from the World Wide Web:  
<http://www.memagazine.org/backissues/june98/features/virtues/virtues.html>
- Gillmore, G. (1998). Assessment and Accountability: The Annual Assessment Report to the Higher Education Coordinating Board of the State of Washington. *Office of Research and Assessment*. Seattle, WA: University of Washington.
- Hai, L. (1997). *Hyperlearning: A Non-Linear, Variable Path, Variable Time, Fixed Outcome Model For On-line Self-assessment and Certification*. Doctoral Dissertation. Fairfax, VA: George Mason University.
- Hanna, D, Glowaski-Dudka, M., & Conceicao-Runlee, S. (2000). *Practical Tips for Teaching Online Groups: Essentials of Web-Based Education*. Overland Park, KS: Atwood Publishing, LLC.
- Harrison, P. J., Seeman, B. J., Behm, R., Saba, F., Molise, G., & Williams, M.D. (1991). Development of a Distance Education Assessment Instrument. *Educational Technology Research & Development*, 39(4), 65-77.
- Henderson, K. (1999). *On Line and on Paper: Visual Representations, Visual Culture, and Computer Graphics in Design Engineering*. Cambridge, MA: MIT Press.
- Hess, A., Zachar, P., & Kramer, J. (2001). *The fourteenth mental measurements yearbook* [Electronic version]. Retrieved March 8, 2006 from Buros Institute: <http://www.unl.edu/buros>
- Hewett, T, Baecker, R., Card, S., Carey, T., Gasen, G., Mantei, M., Perlman, G., Strong, G., & Verplank, W. (1997). *Curricula for Human-Computer Interaction*. New York, NY: ACM SIGCHI Publications.
- Hill, J. R. (1997). *Distance Learning Environments Via World Wide Web*. Englewood Cliffs, NJ: Educational Technology Publications.
- Hirumi, A. (2002). The design and sequencing of e-Learning interactions: A grounded approach. *International Journal on E-Learning*, 1, 19-27.
- Horton, W. K. (2000). *Designing Web-Based Training: How to Teach Anyone Anything Anywhere Anytime*. Hoboken, NJ: John Wiley & Sons.
- Ilabaca, J.S. (2000). To Learn with the Internet: Myths and Realities. *Proceedings 4<sup>th</sup> Iberoamerican Congress on Informatics and Education, RIBIE 2000*, Viña del Mar, Chile Santiago, Chile: University of Chile Press.

- Jegede, O. J., Fraser, B., & Curtin, D. F. (1995). The Development and Validation of a Distance and Open Learning Environment Scale. *Educational Technology Research & Development*, 43 (1), 90-94.
- Jeffries, P. (2000). Development and Test of a Model for Designing Interactive CD-ROMS for Teaching Nursing Skills. *Computers in Nursing*, 18 (3), 118-124
- Jensen, E. (1998). *Teaching with The Brain in Mind*. Alexandria, VA. : Association for Supervision and Curriculum Development Publications.
- Johanson, T. (1996). *The Virtual Community Of An Online Classroom: Participant's Interactions In A Community College Writing Class By Computer Mediated Communication*. Doctoral Dissertation, Oregon State University.
- Jones, E.C. (2001). Hypermedia Aided Instruction: An Investigation of its Effectiveness in elivering Skills Based Training to Information Technology Professionals in the Telecommunications Industry. *Proquest Dissertation Abstracts (UMI No.9989729)*
- Jung, C.G. (1990). *Psychological Types*, ninth printing, revision by Hull, R.F.C. of the translation by Baynes, H.G. Princeton, NJ: Princeton Press.
- Kalameja, A. (2000). *AutoCAD 2000: Assessment Exam Preparation Manual*. Albany, NY: Autodesk Press.
- Kauchak, D.P., Eggen, P.D. & Burbank, M.D. (2005). *Charting a Professional Course: Issues and Controversies in Education*. Upper Saddle River, NJ: Prentice Hall
- Keller J. (1983). *Motivational Design Of Instruction: Instructional Design Theories and Models*. (pp. 386-434) Hillsdale, NJ: Erlbaum.
- Kenny, A. (2002). Online learning: Enhancing nurse education? *Journal of Advanced Nursing*, 38, 127-135.
- Knowles, M., Holton, E.S, & Swanson, R. (2005). *The Adult Learner: The Definitive Classic in Adult Education and Human Resource Development*. St. Lois, MO: Butterworth-Heinemann.
- Konschak, P. E. (2002). *An Evaluation of the Effectiveness of Computer-Based Training For Police Radar Operators*. Minneapolis, MN: Capella University
- Krause, L. (2000). *How we Learn and Why We Don't*. Cincinnati, OH: Thomson Learning.
- Kriewaldt, J. (2001). Metacognition: A Thinking Geography Curriculum. *Geography Teachers Association Publications* (29), 4.

- LaRose, R., Gregg, J., & Eastin, M. (1998). Audiographic Telecourses For The Web: An Experiment. *Journal of Computer-Mediated Communication*, 4(2). Retrieved March 8, 2006 from the World Wide Web: <http://jcmc.indiana.edu/vol4/issue2/larose.html>
- Larson, B.E., & Keiper, T.A. (2002). Classroom discussion and threaded electronic discussion: Learning in two arenas. *Contemporary Issues in Technology and Teacher Education*, 2(1). Retrieved March 8, 2006 from the World Wide Web: <http://www.citejournal.org/vol2/iss1/socialstudies/article1.cfm>
- Lasley, E. (1997). How the Brain Learns and Remembers. *BrainWork* 7 (1), 9-13.
- Lawson, R. (1999). Computer-based training: Is it the next wave? *Professional Safety*.
- Lee, W. W., & Owens, D. L. (2000). *Multimedia-Based Instructional Design: Computer-Based Training, Web-Based Training, and Distance Learning*. Hoboken, NJ: Jossey-Bass.
- Leong, P., Ho, C.P., & Saromines-Ganne, B. (2002). An empirical investigation of student satisfaction with Web-based courses. *World Conference on E-Learning in Corporate, Government, Healthcare, & Higher Education*, 2002(1), 1792-1795.
- Levy, P. & Lemeshow, S. (1999) *Sampling of Populations: Methods and Applications*. Hoboken, NJ: John Wiley & Sons (Wiley-Interscience)
- McCabe, M. (1997). *Online Classrooms: Case Studies Of Computer Conferencing In Higher Education*. Doctoral Dissertation, New York, NY: Columbia University Teachers College.
- Meshor, D. (1999). Designing Interactivities for Internet Learning. *Syllabus*, 13 (7), 16-20.
- Moore, G.S., Winograd, K., & Lange, D. (2001). *You CAN Teach Online! The McGrawHill Guide to Building Creative Learning Environments*. Columbus, OH: McGraw-Hill Companies.
- Morris, S. (2002) *Teaching and Learning Online*. Lanham, MD: Scarecrow Press, Inc.
- Morris, N., Buck-Rolland, C., & Gagne, M. (2002). From bricks to bytes: Faculty and student perspectives of online graduate nursing courses. *CIN: Computers, Informatics, Nursing*, 20, 108-118.
- Odem, M. & Griffin, R. A. (1999). Embracing technology is reaping rewards. *School Business Affairs*, 65 (2), 7-10.

- OES-UW (2002). *Educational Assessment Form E*. Office of Educational Assessment. Seattle, WA: University of Washington.
- O'Quinn, L. & Corry, M. (2002). Factors that Deter Faculty from Participating in Distance Education. *Online Journal of Distance Learning Administration*, 5(4) Winter, 1-17.
- Pachnowski, L. & Jurczyk, J. (2003). Perceptions of faculty on the effect of distance learning technology on faculty preparation time. *Online Journal of Distance Learning Administration*, 6(3), 1-10.
- Palloff, R. M., & Pratt, K (2001) *Lessons From the Cyberspace Classroom: The Realities Of Online Teaching*. San Francisco, CA: Jossey-Bass Publications.
- Pappas, J.P., & Jerman, J. (2004). *Developing and Delivering Adult Degree Programs: New Directions for Adult and Continuing Education*. Indianapolis, IN: Wiley Publishing.
- Park, O., & Seidel, R. J. (1989). A Multi-disciplinary Model for Development of Intelligent Computer-Assisted Instruction. *Educational Technology Research & Development, (ETR&D)*, 37 (3) 81-94.
- Pascarella, E.T., & Terenzini, P.T. (2001). *How College Affects Students: Findings and Insights from Twenty Years of Research*. Hoboken, NJ: Jossey-Bass Higher and Adult Education.
- Payne, D. A. (2002). *Applied Educational Assessment*. Florence, KY: Wadsworth Publishing Company.
- Payne, C.R. (2002). Good practice and motivation in online courses. *Virtual University Gazette*. Retrieved March 8, 2006 from the World Wide Web: <http://www.geteducated.com/vug/index.asp>
- Perelman, L. (1992). *School's Out: Hyperlearning, the New Technology*. New York, NY: William Morrow & Co. Publications.
- Pistillo, D. (1996). Hyperlearning: A Hybrid Model for Higher Education. White paper. Tempe, AZ: *University of Advanced Computer Technology (UACT)*.
- Pittinsky, M. (2002) *The Wired Tower: Perspectives on the Impact of the Internet on Higher Education*. Indianapolis, IN: Prentice Hall Publications.
- Poonwassie, D. H., & Poonwassie, A. (2001). *Fundamentals of Adult Education: Issues and Practices for Lifelong Learning*. Toronto, Ontario: Thompson Educational Publications.

- Provenzo, E.F., Brett, A. & McCloskey, G.N. (1999). *Computers, curriculum and cultural change*. Mahwah, N.J.: Lawrence Erlbaum Associates.
- Ratcliff, J.L., Johnson, D.K., & Gaff J.G. (2004). *Changing General Education Curriculum: New Directions for Higher Education*. Indianapolis, IN: Jossey-Bass
- Relan, A., & Gillani, B. (1997). *Web-Based Instruction And The Traditional Classroom: Similarities And Differences*. Englewood Cliffs, NJ: Educational Technology Publications.
- Roblyer, M.D., (2004). *Educational Technology in Action*. Upper Saddle River, NJ: Prentice Hall
- Rothwell, W.J., Butler, M., Maldonado, C., Hunt, D., Peters, K, Li, J. (2006). *The Handbook of Training Technologies: An Introductory Guide to Facilitating Learning with Technology - from Planning to Evaluation*. Indianapolis, IN: Wiley Publishing.
- Salmon, G. (2000). *E-Moderating: The Key to Teaching and Learning Online (Open and Distance Learning Series)*. London, UK: Kogan Page, LTD Publishers.
- Schutte, J. (1997). Virtual Teaching In Higher Education: The New Intellectual Superhighway Or Just Another Traffic Jam. *California State University*. Retrieved March 8, 2006 from the World Wide Web: <http://www.csun.edu/sociology/virexp.htm>
- Scuito, G.T. (2002). Setting students up for success: The instructor's role in creating a positive, asynchronous, distance education experience. *Virtual University Gazette*. Retrieved March 8, 2006 from the World Wide Web: <http://www.geteducated.com/vugaz.htm>
- Sigmund T., & Fletcher, J.D. (2000). *Training & Retraining: A Handbook for Business, Industry, Government, and the Military*. New York, NY: Macmillan Reference.
- Simonson, M., Smaldino, S., Albright, & Zvacek, S. (2005). *Teaching and Learning at a Distance: Foundations of Distance Education*. Upper Saddle River, NJ: Prentice Hall Publications.
- Statistical Abstracts of the United States. (2002) *U.S. Census Bureau, Administrative and Customer Services Division, Statistical Compendia Branch*. Last Revised: December 4, 2002.
- Steele, J. (2001). *Architecture and Computers: Action and Research in the Digital Design Revolution*. New York, NY: Watson-Guption Publications

- Sutherland, I. E. (1963) *Sketchpad: The First Interactive Computer Graphics*  
Ph.D. Thesis, Cambridge, MA: Massachusetts Institute of Technology.
- TechEncyclopedia (2003). Definition of Technical Terms. *Retrieved from the World Wide Web on March 8, 2006: <http://www.techweb.com/encyclopedia/>*
- Techtarget (2003). An Online Technology reference Guide. *Retrieved from the World Wide Web on March 8, 2006: [http://www.techtarget.com/html/ab\\_index.htm](http://www.techtarget.com/html/ab_index.htm)*
- Thurmond, V.A., Wambach, K., Connors, H.R., & Frey, B.B. (2002). Evaluation of student satisfaction: Determining the impact of a Web-based environment by controlling for student characteristics. *The American Journal of Distance Education*, 16, 169-189.
- Tinto, V. (1997). Universities as Learning Organizations. *About Campus* (6), 2-4.
- Torre, M. (2000). *Celebrating Computers in Engineering*. New York, NY: American Society of Mechanical Engineers.
- UWA (University of Western Australia), (2000). Alternative Modes of Teaching and Learning. *Retrieved from the World Wide Web on March 8, 2006: <http://www.acs.uwa.edu.au/csd/tl/report.rtf>*.
- Van Dusen, G. C. (2000). *Digital Dilemma: Issues Of Access, Cost, and Quality in Media-Enhanced and Distance Education*. San Francisco, CA: Jossey-Bass Publications.
- Verplank, B., & Kim, S. (1987). Graphic invention for user interfaces: An experimental course in user-interface design. *ACM SIGCHI Bulletin*, 18 (3), 50-66.
- Webster, J., & Hackley, P. (1997). Teaching Effectiveness In Technology-Mediated Distance Learning. *The Academy of Management Journal*, 40(6), 1282-1309.
- West, R.P. (1998). Reducing the Barriers. *EDUCAUSE*. 21(2), 6-7
- Wilson, A. L., & Hayes E. (2000). *Handbook of Adult and Continuing Education*. Hoboken, NJ: Jossey-Bass Higher and Adult Education.
- Winkleman, M. (1999). The Applications of Hyperlearning in the Classroom. Santa Clara, CA: *Conference presentation at Syllabus '99*.
- Zoeller, M.A. (2000). Technology Integration in United States. Retrieved March 8, 2006 from the World Wide Web:  
<http://courseweb.tac.unt.edu/rhondac/ss2000/cecs5800/papers/Maroba.pdf>