

4-1-1978

Volume 2, Number 4 (April 1978)

The OTEC Liaison

Follow this and additional works at: http://nsuworks.nova.edu/nsudigital_otec-liaison

 Part of the [Energy Policy Commons](#), [Environmental Studies Commons](#), [Natural Resources Management and Policy Commons](#), [Oceanography Commons](#), [Oil, Gas, and Energy Commons](#), [Science and Technology Studies Commons](#), and the [Water Resource Management Commons](#)

NSUWorks Citation

The OTEC Liaison, "Volume 2, Number 4 (April 1978)" (1978). *The OTEC Liaison*. Paper 8.
http://nsuworks.nova.edu/nsudigital_otec-liaison/8

This Newsletter is brought to you for free and open access by the NSU Digital Collections at NSUWorks. It has been accepted for inclusion in The OTEC Liaison by an authorized administrator of NSUWorks. For more information, please contact nsuworks@nova.edu.

Offshore Technology Conference Draws Record Crowds

FERTILIZER PRODUCER - OFFSHORE CONTRACTOR TEAM PROPOSED

Over 70,000 scientists, engineers, businessmen, and political leaders came to Houston May 8th through 11th for the 10th Offshore Technology Conference, the largest industrial conference ever held in the United States. Representatives from China, Russia, and 95 other foreign countries attended the meeting in the Astrodome complex, where 1800 companies exhibited and more than 300 papers on

Private OTEC Plant Proposed

One of the highlights of the paper presented by E. L. "Bud" Francis of the Applied Physics Laboratory of Johns Hopkins University was a proposal of partnership between firms now producing and distributing ammonia and the large offshore construction firms, via an OTEC plant. In his

ment for six to eight months. In advancing the commercialization aspects of OTEC, it was pointed out that it is now competitive with nuclear energy and coal, has no environmental problems or shortages of raw material, and is not subject to strikes as are the other major energy-producing industries. Also, once an OTEC plant is in operation, 77% of the costs are fixed.

Lavi Tells of Tentative Heat-Exchanger Conclusions

At the beginning of Dr. Abraham Lavi's paper, he pointed out that while he was a representative of the Department of Energy, he was at the same time a "free agent", and his remarks were not intended to be taken as official policy of that Department. He told his listeners that Southwest Engineering of Los Angeles, a subcontractor to TRW, had decided that the best way to go with heat exchangers would be the shell-and-tube type constructed of titanium, using spray evaporators and no enhancement. He predicted that an OTEC plant would be at sea by early 1980.

Antonio Parazzulo of Technomare s.p.a. of Italy told the meeting that a "100 MWe plant can be built in existing shipyard facilities throughout the world, four of which are in the United States"—countering the concern of some that OTEC plants, due to their size, would be difficult to construct.

(continued on Page 3)

The OTEC Liaison

VOLUME 2, NUMBER 4
April 1978

all aspects of offshore-resources development were presented. The conference, sponsored by 11 international and scientific societies, has grown tremendously since its inception in 1969, when 4300 people attended, 125 papers were delivered, and only 120 companies participated.

Much of the conference focused on energy and how to obtain it while protecting the fragile marine environment, but there were also discussions and exhibits on ocean mining and food production. OTEC was presented in various aspects at one well-attended technical session, with papers presented by Abe Lavi of DOE, Bud Francis of APL, Bob Waid of Lockheed, and others. Among the exhibitors were many firms active in the OTEC program, including TRW, Lockheed, Alfa-Laval, ODECO, SEDCO, and Global Marine.

SEDCO Turned Down on OTEC-1

It was learned by *The OTEC Liaison* during the conference that the Department of Energy had advised SEDCO (Southeast Drilling and Exploration Company: see story in April issue of OTC) that their bid for the OTEC-1 platform had been rejected. The main reason given was that their bid included cold-water-pipe (CWP) construction of fiberglass and their method of attachment of the CWP "was not suitable". This leaves Lockheed, Global Marine/TRW, and ODECO (Offshore Drilling and Exploration Company: see story elsewhere in this issue) still in the running for this major contract.

presentation Francis pointed out that 98% of all ammonia in the United States was produced from natural gas, with 78% of this chemical being currently distributed in the Midwest. With the advent of natural-gas shortages likely, this proposed marriage seems an ideal opportunity for heavy private investment in OTEC.

Francis told the meeting that this type of relationship has been under develop-



One of the OTEC-related exhibitors at the Houston OTC conference was Alfa-Laval. Examples of their heat-exchanger plates are in the background. That's Dr. Ken Bell, a conference attendee, in the foreground.

PHOTO: TOL

The OTEC Liaison

AN INTERNATIONAL NEWSLETTER
ENGAGED AS LIAISON FOR THE
COMMUNITY OF OCEAN THERMAL
ENERGY CONVERSION

VOLUME 2, NUMBER 4
April 1978

EDITOR/PUBLISHER
Richard Arlen Meyer

WASHINGTON EDITOR
John O. Ludwigson

TYPESETTER
AND COPY EDITOR
Shelly Treshansky

ART DIRECTOR
Pamela Greenfield

BUSINESS MANAGER
Robert Bernstein

CIRCULATION MANAGER
Denise Apter

SUBSCRIPTION MANAGER
Kathleen Guido

The OTEC Liaison is published monthly by Popular Products, Inc., 1910 N. Elston Ave., Chicago, Illinois 60622, USA; (312) 489-5900. Our Washington office is at 1254 National Press Building, Washington DC 20045, USA; (202) 783-2842. Copyright 1977 by Popular Products, Inc., Chicago, Illinois. All rights reserved. Contents of this newsletter may not be reproduced in whole or part without permission. Printed in USA. Unsolicited manuscripts must be accompanied by a stamped, self-addressed envelope for return. The OTEC Liaison will not assume responsibility for unsolicited manuscripts or photographs. The OTEC Liaison will not assume responsibility for manuscripts or photographs left or submitted on speculation. Subscription prices: United States and possessions: one year \$80, universities \$70. Foreign: Add \$5. Single copies: US \$6 each, Foreign \$6.50.

Please Subscribe!

The OTEC Liaison will provide continued liaison [from the French: *an instance or means of communication between bodies, groups, or units*] to the community of ocean thermal-energy conversion, with response to your expressed needs. Your comments and criticisms are welcomed.

(The following story, which appeared on May 15th, 1978, is reproduced with permission from The Wall Street Journal.)

OLD DREAM OF ENERGY FROM WARMTH OF SEA GETS NEW IMPETUS

Japanese Engineers Suggest
Mix of Water, Nitric Acid
To Raise Heat Extraction

by Jerry E. Bishop
Wall Street Journal
Staff Reporter

A novel method of extracting solar energy from the sun-warmed surface waters of oceans was proposed by two Japanese engineers.

The pair, both at Yokohama National University, proposed what amounts to a new kind of chemical heat engine, in effect powered by water warmed by the sun or by industrial processes.

A keystone of the method is the fact that when a small amount of water is mixed with concentrated nitric acid, the solution will heat up by several degrees. The engineers outlined a plan whereby the water-nitric-acid reaction could be carried out repeatedly, to parlay or upgrade the warmth of the sea surface into a sizable amount of usable heat.

The proposal is outlined by N. Wakao and K. Nojo, of the University's chemical-engineering department, in the May issue of a British magazine, *Nature*.

The novel heat engine is the latest of many proposals, some dating back almost a century, aimed at exploiting the temperature difference between the sun-warmed surface waters of the oceans and colder waters deeper down. The schemes usually involve using the warmer water to produce a vapor to drive a turbine and then using the colder water to condense the vapor.

As early as 1930, for example, a French scientist built a small power plant near Cuba that produced 22 kilowatts of power by such means, according to an article by Gordon L. Dugger of Johns Hopkins University in the McGraw Hill *Energy Technology Handbook*. In the plant, surface seawater was run into a low-pressure chamber. In the near-vacuum of the chamber the warm water would vaporize, and the resulting steam was used to run a turbine. Cold seawater from below the surface would then be used to condense the steam.

More recently, according to Mr. Dugger, researchers have proposed using the sun-warmed surface waters to vaporize such volatile fluids as ammonia or propane. The vapors would be used to drive a turbine, after which they would be cooled and condensed by the cold seawater. The cold liquid ammonia or propane would then be boiled again by the warm seawater, and the cycle repeated. Thus, the solar

energy stored as heat in the warm surface water is converted to usable mechanical energy.

In such operations, the greater the difference in temperature between the surface and deeper seawater, the more energy released to drive the turbine. Mr. Dugger notes that in tropical seas there may be as much as 20 degrees Celsius (68 degrees Fahrenheit) difference between the surface waters and the deep waters, which could drive rather sizable power plants.

The novelty of the Japanese proposal is the use of the water-nitric-acid reaction to greatly boost the amount of heat that can be extracted from the tepid seawater.

In their article, Messrs. Wakao and Nojo note that if a kilogram (2.2 pounds) of concentrated nitric acid is diluted with 0.4 to 0.8 kilogram of distilled water, the resulting solution will heat up by about 20 degrees C (68 degrees F). Thus, if the distilled water is 26 degrees C, mixing it with concentrated nitric acid will produce a solution that heats up by chemical reaction to 46 degrees C.

In their proposal, the initial step would be to produce a 20-degree boost in temperature by mixing nitric acid and distilled water. The added heat would be drawn off by a heat exchanger. The diluted nitric-acid solution would then be piped into a low-pressure chamber that acts as a still. In the low pressure, sun-warmed surface seawater at a tepid 26 degrees C (79 degrees F) would be warm enough to boil water out of the solution.

The newly reconcentrated nitric acid would be piped out of the bottom of the still. Meanwhile, the water vapor rising to the top would be piped into a condenser cooled by deep-sea water. The resulting distilled water and reconcentrated nitric acid would then be mixed again to produce another 20-degree boost in temperature. Constantly repeating the cycle, using only the sun-warmed seawater as a heat source for the still, would produce a steady flow of low-level heat.

In one arrangement suggested by the engineers, several such units could be put in tandem, each adding heat until temperatures of 100 degrees C (212 degrees F) were reached.

The engineers said they didn't know whether such a system could produce heat economically for electricity generation or industrial processes. That would depend on the cost of the materials and how efficiently the heat could be extracted, as well as on the cost of running the pumps.

"Although its economic feasibility isn't yet established, we expect that the process of extracting pollution-free thermal energy of a higher temperature from solar sea energy or waste heat will become a promising candidate as a new energy source," they wrote.

(Reprinted with permission of *The Wall Street Journal*, © 1978, Dow Jones and Company, Inc. All rights reserved.)

(continued from Page 1)

Confusion on Economic Assessments

In an open discussion following Abe Lavi's presentation, Bud Francis took exception to the idea that economic assessment by DOE seemed to be predicated on a 10-year life expectancy for an OTEC plant. He pointed out that the National Science Foundation had previously used a 50-year figure, which was later reduced to 30 years by ERDA, and had now been cut down to 10 years by DOE. Abe Lavi responded by saying that there was no firm DOE policy, "however based on a 30-year life and with *no* help from the government, an OTEC plant would pay off in 15 years." This was based on the less-costly use of aluminum in the heat exchangers. It was also observed that the economic assessments of Lockheed, TRW, and Westinghouse were roughly about 50% more costly than those of the Applied Physics Laboratory. Needless to say, a discussion followed on why this should be so.

An Important Conference for OTEC

With the offshore oil industry becoming increasingly interested in OTEC, it is suggested that everyone involved in the OTEC program attend next year's Offshore Technology Conference. As one of the speakers pointed out, after touring the multiple and massive exhibits of firms with 20 years' experience in offshore exploitation, "It's worthwhile to actually *see* just how much can be done in the oceans." Many of the occasional obstacles to OTEC development seem small when one sees how far the world's offshore technology has progressed. **Make plans now to attend the conference at Houston, April 30th to May 3rd, 1979.**

SOLAR REVIEW AVAILABLE

"Solar-Energy Research and Development: Program Balance", COE/IR-0004, February 1978, is available at the National Technical Information Service (NTIS) for \$4.50. This Department of Energy report was a review by the General Advisory Committee of the Energy Research and Development Administration, which became the Solar Working Group when ERDA was incorporated into the Department of Energy last October. Copies may be ordered from NTIS at 5285 Port Royal Road, Springfield VA 22161.

Two documents done for the Solar Working Group by SRI International, entitled "Solar-Energy Research and Development: Program Balance", Annex, Volume I, HCP/M2693-01, and Volume II, HCP/M2693-02, provide more detail. The two volumes are expected to be available from NITS in the near future.

NEW "MINI-OTEC" DEMONSTRATION PLANT PLANNED FOR HAWAII

The Hawaiian government, The Dillingham Corporation, and Lockheed Missiles and Space Company have reached a tentative agreement to begin preliminary engineering design of a 50-kilowatt plant that will demonstrate the technology available today to produce electrical power from the sea. Lockheed's James G. Wenzel, Vice-President for Ocean Systems, announced in late April that the first phase of the project, preliminary engineering design, will provide sound cost estimates in the \$1 million to \$2 million range for the project and will form a basis for decision-making on subsequent phases of the program. Phase I will be completed in two to three months.

Costs of the Mini-OTEC plant will be shared by the state and industry. Wenzel said the plant will prove the feasibility of ocean thermal-energy conversion as a non-polluting power source. It could be an important milestone in Hawaii's search for energy independence. Dillingham, headquartered in Honolulu, is an international firm active in shipping, mining, construction, energy, and property management.

TRW RECEIVES OTEC CONTRACT

Under a recently-signed DOE contract, TRW Inc. Defense and Space Systems Group, Redondo Beach, California, will begin designing OTEC systems.

TRW will prepare conceptual and preliminary designs of a commercial-scale (OTEC) power system and of a smaller pilot plant that will be a scaled-down version of the larger system.

Although exact sizes will be determined during the design efforts, a commercial-size OTEC system conceivably might link several individual modules, each generating as much as 50,000 kilowatts.

In addition to its design efforts, TRW will build a 1,000-kilowatt heat exchanger for testing on board OTEC-1, an ocean-going test platform being used by DOE to test and evaluate individual OTEC components.

TRW, whose contract totals \$2.64 million, is one of three organizations selected last summer to work on OTEC power-system designs. Earlier this year, DOE signed similar contracts with Westinghouse Electric Corporation and Lockheed Missiles and Space Company.

Following completion of the designs in September 1978, DOE will select one or more for actual fabrication of an ocean-based pilot plant producing between 5,000 and 12,000 kilowatts of electricity.

Attendance at the tenth annual Offshore Technology Conference in Houston in May was 79,689 persons—over 20% more than the previous year.

US FACILITIES TO PRODUCE LARGE-DIAMETER PIPE EXPANDED

While the last remaining major hurdle in development and production of large-diameter pipe for OTEC plants is receiving increased attention, US Steel has recently announced that it will expand its present production capability of 48-inch-wide pipe. Decisions regarding the use of steel, aluminum, concrete, rubber, or plastics for OTEC cold-water pipe (CWP) are still pending, but the nation's largest steelmaker said its expansion of a present facility at its McKeesport, Pennsylvania plant will provide "a broader participation in the growing market" for large-diameter pipe used in gas, oil, and coal slurry production lines. Last October US Steel built the nation's first mill capable of producing 48-inch-wide steel pipe at its Baytown, Texas works. The new McKeesport expansion will begin this month so that output can begin in December.

While *The OTEC Liaison's* delivery schedule could be improved, it's a far cry from the record of DOE's Solar Energy Research and Development Report. Two copies of the same issue, dated May 1st, were received by *The OTEC Liaison*—one on May 15th and the other the next day. The lead story was on DOE's activities for Sun Day, May 3rd.

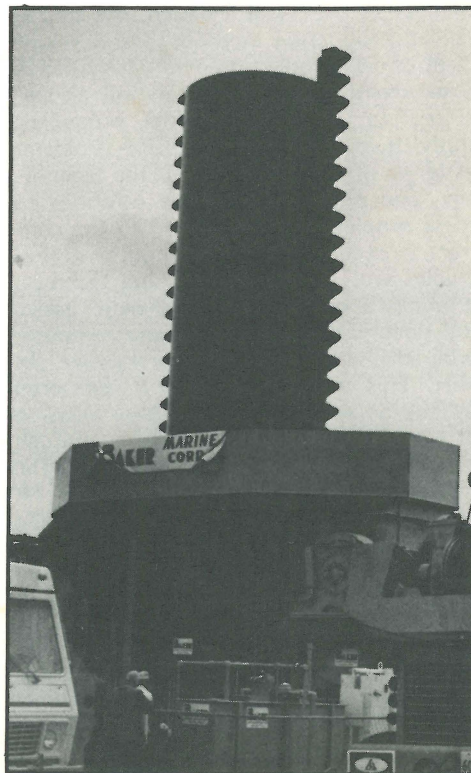

PHOTO: TOL

One of many exhibits in Houston too large even for the Astrodome was this pipe-lowering machine by Baker Industries. It can lower 250 feet per hour, and has carried 25,000 tons. Maybe when the cold-water pipe is ready . . .

OCEAN RESOURCES

While the dissemination of information about OTEC development is the prime purpose of this publication, information about other ocean energy resources, such as wave and tidal energy, salinity gradients, and biomass conversion, and inter-related technologies such as deep-sea mining and aquaculture is also being brought to the attention of readers of *The OTEC Liaison* from time to time.

DEEP OCEAN MINING COULD BE PROFITABLE, MIT STUDY FINDS

**Manganese Nodule Venture
Seen Producing 15%-22%
Return on an Investment**

By a *Wall Street Journal*
Staff Reporter

Cambridge MA: Deep-ocean mining of key minerals looks like a profitable enterprise with a high strategic value for the US, a team of scientists at the Massachusetts Institute of Technology has asserted.

A mining venture designed to scoop up manganese nodules from the ocean floor might produce a return on investment of 15% to 22%, according to projections run through a computer model that the report describes.

The report deals with prospects for scooping, or sucking up, ferromanganese nodules from the sea bed. Such nodules, averaging about the size of squash balls, are found in abundance, particularly in the eastern equatorial Pacific Ocean, the report says.

The computer model assumes recovery of nodules containing about 1.5% nickel, 1.3% copper, 0.24% cobalt, and 26.9% manganese. A viable US industry mining these nodules could protect the US from foreign economic pressures as domestic land-based supplies run short toward the end of this century, the report says.

The study was compiled by MIT students led by J. D. Nyhart, an associate professor of management at MIT's Sloan School of Management, and written for MIT's sea-grant program, which deals with ocean subjects.

The purpose of the model is to enable governments and companies to analyze how various policy options and economic factors could affect a deep-sea mining venture.

Although the model is flexible and able to use a variety of different assumptions, the basic venture that it takes as a starting point for analysis would involve a "mine site" in about 18,000 feet of water about 2,640 miles from the nearest port with about two pounds of nodules per square foot of ocean floor. The model venture

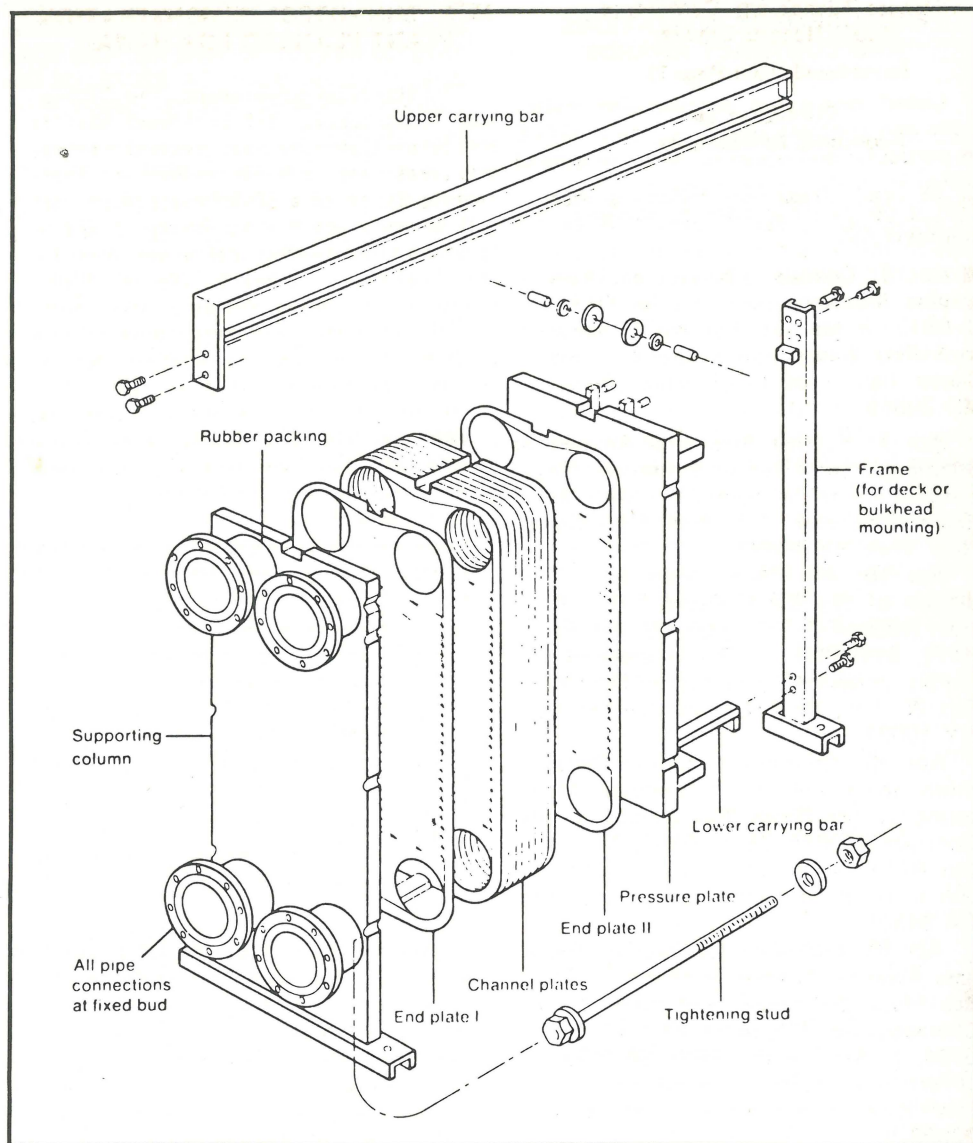

Exploded view of Alfa-Laval plate heat exchangers, using plates similar to that illustrated on the cover of this issue.

would require investment of about \$560 million before it began to return any income from the sale of refined minerals. Total annual revenue from such a venture in its sixth through 30th years might be about \$250 million after operating expenses of \$100 million.

According to the study, four North American-based groups have actually spent an estimated \$100 million to \$150 million on deep-ocean prospecting, exploration, and research and development.

Members of these groups include affiliates of US Steel Co., Sun Oil Co., Kennecott Copper Corp., Inco Ltd., Standard Oil Co. (Indiana), Royal Dutch/Shell Group, and Lockheed Corp., among others.

In another development, Ocean Management Inc., one of the groups testing seabed mining techniques, said it successfully pumped a continuous stream of manganese nodules aboard a pilot ocean-mining

ship in a recent test. Ocean Management, which includes Inco Ltd., Toronto, Sedco Inc. of the US, and a number of West German and Japanese concerns, said the nodules were picked up from a depth of about three miles.

The group added, however, that while the test was "a significant technical achievement", it has decided to reduce the scope of its feasibility study because of the uncertain outlook for nickel and copper markets and uncertainty over future rules that may apply to ocean mining. The group, which originally planned to investigate the mining, processing, and marketing of ocean-mined minerals, now will stop work after completion of the current mining test, Ocean Management said.

(Reprinted with permission of *The Wall Street Journal*, © 1978, Dow Jones and Company, Inc. All rights reserved.)

CREDIT: ALFA-LAVAL

**US GOVERNMENT
PROCUREMENT INVITATIONS
AND CONTRACT AWARDS**

Listed below are procurement invitations and contract awards related to OTEC in particular and ocean resources in general culled from the *Commerce Business Daily*. This is not to be construed, however, as a complete list.

● **Apr 3: Conduct Analyses on Oceanographic Moorings:** Contract N00014-78-C-0319, 9 Mar 78 (no RFP), \$59,929, to EG&G Washington Analytical Services Center Inc., 2150 Fields Road, Rockville MD 20850.

Apr 7: Further Structural Analysis of Submerged and Floating Structures: Negotiations are to be conducted with Weidlinger Associates, 110 East 59th Street, New York NY 10022.

Apr 10: Additional Research on Prediction of Worldwide Ocean Tides: Contract N00014-75-C-0605, 22 Mar 78 (no RFP), \$140,000, to The Trustees of Columbia University in the City of New York, Box 20, Low Memorial Library, New York NY 10027.

Apr 10: Continue to Utilize Radar to Study the Feasibility of Remotely Monitoring Surface Winds, Waves, and Currents: Contract N00014-75-C-0356, 23 Mar 78 (no RFP), \$184,300, to Leland Stanford Junior University, Old Pavilion, Stanford CA 94305.

Apr 10: Additional Research to Investigate Acoustic Parameters of the Sea Floor, Sea-Floor Sediments, and Internal Wave Characteristics: Contract N00014-75-C-0704, 17 Mar 78 (no RFP), \$603,504, to University of California, San Diego, Scripps Institution of Oceanography, La Jolla CA 92093.

Apr 10: Further Research on Mechanical Behavior of Titanium Alloys: Contract N00014-76-C-0598, 17 Mar 78 (no RFP), \$97,352, to Rockwell International Corp., Science Center (L), PO Box 1085, Thousand Oaks CA 91360.

Apr 10: Study of Ocean Fine Structure: Contract NAS 6-2888, 22 Mar 78, for \$50,043, to the Johns Hopkins University, 34th and Charles Streets, Baltimore MD 21218. NASA, Wallops Flight Center, Wallops Island VA 23337.

Apr 12: Fuels From Biomass Program: Herbaceous-species screening program to identify species which have high productivity and would be suitable for biomass energy farms. Contractor will be required to conduct a preliminary assessment of the potential herbaceous plants for energy farms, recommend species which are to be screened in each of six discrete regions of the US, provide technical guidance and project management for subcontractors who perform field screening trials and evaluate the results. Cite RFP ET-78-R-01-3100. All requests must be in writing. Department of Energy, Office of Procurement Operations, Washington DC 20545. Attn: Document Control Specialist.

● **Apr 12: OTEC Power System Development Program:** Contract EG-77-C-03-1570, \$2,643,251, to TRW Inc., One Space Park, Redondo Beach CA 92078. US Department of Energy, 1333 Broadway, Oakland CA 94612.

Apr 12: Navstar Global Positioning System Library Update: The following documents have been placed in the GPS Library: (A) Aero 120-1834 (Copy 2), 8 Mar 78: Preliminary documentation for MS phased array antenna. (B) MC409-0018, 1 Dec 76: PRN Signal Assembly Performance, Design, Development, and Test Requirements. (C) Tor-0059(6110-01)-3 Reissue C, 10 Jun 75: Air Force Satellite Control Facility Space/Ground Interface. (D) Yen 78-019 Rev 1, 10 Mar 78: Requirements for the Phase II/III control segment of the Navstar Global Positioning System. Revisions to existing documents are as follows: (A) Yen 76-208F: Orbital Requirements Document Navstar Global Positioning System Revision F, 15 Feb 78. (B) CP-CS-305, Part 1, 16 Dec 77: Computer Program Development Specifications for the GPS Master Control Station Navigation Subsystem Message Formatter Computer Programs. The GPS Library will be updated periodically. Notifications will follow as required. Headquarters, Space and Missile Systems Organization (AFSC) (PMN), PO Box 92960, Worldway Postal Center, Los Angeles CA 90009.

Apr 13: Fabrication of Deep-Sea Tow Cable: The electrical core of the cable will require dimensional and electrical characteristics similar to an RG-17 coaxial cable. The strength member will be an armor consisting of two layers of contrahelically wrapped high-strength composite material. The composite material will be PRD-49-111 filaments in a polyurethane matrix, possibly jacketed. The cable will be approximately 23,000 feet. Interested firms fulfilling the following prerequisites are invited to respond for evaluation and consideration of company capabilities: (1) Previous experience in building coaxial undersea cables, using both metallic and non-metallic strength members. (2) Manufacturing equipment with adequate versatility to permit adjustment of lay lengths of the armor layers to insure that the cable will be torque-free and rotation-free. This equipment must also be instrumented to continuously monitor (and provide process control of) concentricity, dielectric diameter, and jacket thickness. (3) Available adequate electrical measuring equipment to determine characteristic impedance, RF attenuation, corona, conductor resistance, insulation resistance, and time-domain reflectometry for the finished cable. Such instrumentation need not be permanent capital equipment, but must be on hand during acceptance testing with verifiable calibration certificates. This is not a request for proposal for bids, and only responses containing information adequate for evaluation will be considered. Re-

sponses should reference schedule SK78-0930, Attn: Code CDB-50. Responses should be received by the listed purchasing office no later than 21 days from the date of this notice. Only those firms deemed qualified will be solicited for a proposal. OIC, Naval Regional Procurement Office, Long Beach CA 90822.

Apr 14: Further Research of a Seawater Temperature Sensor and Telemetry for the HLF-3 Sound Source: Negotiations are to be conducted with Hydroacoustics Inc., 321 Northland Ave., PO Box 3818, Rochester NY 14610. Office of Naval Research, 800 North Quincy, Arlington VA 22217.

Apr 14: Study of Energy Requirements for the Period 1977 to 2000 (Regional and National) Using the Energy Supply Planning Model Developed and Owned by Bechtel: Contract A06-78-1321SD being negotiated with Bechtel National Inc., PO Box 3965, San Francisco CA 94119.

Apr 14: Ocean Color Measurement Study Utilizing an Airborne Sensor Package: RFP N66001-78-R-0229. Negotiations will be conducted on a sole-source basis with ESCA-TECH Corp., 3001 Red Hill Ave., Suite 212, Costa Mesa CA 92626.

Apr 14: Research/Development/Demonstration Opportunities in Solar Energy: The Division of Solar Technology, US Department of Energy, has published a Guide to Solar-Energy Programs, March 1978, Document DOE/ET-0036, which describes the various solar technologies as well as applicable procurement methods. This document is available from National Technical Information Service (NTIS), US Department of Commerce, 5285 Port Royal Road, Springfield VA 22161. Prices are \$5.25 for a printed copy and \$3 for microfiche. Telephone orders: 703/557-4650 (101). Department of Energy, Division of Solar Technology, Washington DC 20545.

Apr 14: Analysis of the Establishment of the Naval Ocean Systems Center: Negotiations will be conducted on a sole-source basis with Santa Fe Corp., Alexandria VA, based on an unsolicited proposal: RFP N66001-78-R-0233/GE8.

Apr 17: Hydrogen Attack of Steel: Contract EY-76-S-02-2672.A0003, for \$41,257, to Ohio State University Research Foundation, Columbus OH 43212.

Apr 17: Catalyzed Water/Steam Gasification of Biomass: Contract ET-78-C-02-4736.A000, for \$302,129, to Wright-Malta Corp., Baliston Spa NY 12020.

Apr 17: Additional Research on the Variable Structure of the Interior of the Deep Ocean: Contract N00014-75-C-0155, 30 Mar 78 (no RFP), for \$487,612, to the Regents of the University of California, Contracts and Grants Office, SIO, Code A-010, University of California at San Diego, La Jolla CA 92903.

● **Apr 17: Further Research on Self-Implanting Moorings:** Contract N00014-77-C-0230, 29 Mar 78 (no RFP), \$57,288, to Woods Hole Oceanographic Institution, Woods Hole MA 02543.

Apr 17: Operation of National Energy Information Affiliate: Contract EI-78-C-01-8285 (no RFP), for \$491,709, to University of New Mexico, Albuquerque NM 87131.

Apr 18: Further Modification of an Oceanographic Sensor Package Known As Ocean Environmental Sensing Equipment to Operate in a Digital Mode: Negotiations are to be conducted with the Charles Start Draper Laboratory Inc., 555 Technology Square, Cambridge MA 02139.

Apr 18: Citizen Involvement in Renewable Sources of Energy: Contract EU-78-G-01-6308 (grant), for \$186,970, to Solar Action Inc., Washington DC 20036.

Apr 20: Study of the Mass Production and Industrialization of Small Solar Thermal Electric Power Systems: Planned for release in May 1978. The overall goal of the SPSA Project is the commercial availability of small (1 to 10 MWe) solar thermal electric power systems by the later 1980s. As part of its analytic program in support of this goal, JPL has identified the need for a comprehensive manufacturing analysis of these systems. The objectives of this study are to determine quantitatively the potential for system cost reduction through mass production and to characterize the factors, issues, and problems inherent in the transfer of this technology to the manufacturing sector. For given system concepts and designs, the contractor will be required to define mass-production scenarios and cost them out. These scenarios must include full consideration of production options such as changes in the system design, use of advanced production methods, and development of new production methods via R&D. Concurrently the contractor will be required to identify potential producers, study them in depth, identify problems in terms of their adoption of the technology, and determine possible solutions to these problems. The duration of the contract is expected to be 14 months. Deliverables will include reports and technical briefings upon completion of major tasks, full documentation of data and computer programs, and a final comprehensive report. This technology effort is sponsored by the Solar Energy Technology Division of the US Department of Energy through an interagency agreement with NASA. The California Institute of Technology's Jet Propulsion Laboratory (JPL), operating under a prime contract with NASA, will release the RFP. The JPL requests that all interested firms which have a capability in this area provide a written expression of interest to the JPL no later than 20 days from the date of publication of this synopsis. Telephone inquiries will not be honored. This is not a request for proposal. No additional information is available at this time. Jet Propulsion Laboratory, 4800 Oak Grove Drive, Pasadena CA 91103, Attn: O. Figueroa, MS 506-401.

Apr 21: Priority at the Pump: Study of possible means of dispensing motor gasoline in order to limit the length of queues during a severe shortage resulting from an oil embargo or other supply interruption. RFP EB-78-R-01-6299 to be issued the week of 24 Apr 78. Proposals will be due 20 days after release. All requests must be in writing. No telephone requests will be honored. Department of Energy, Office of Procurement Operations, Washington DC 20545, Attn: Document Control Specialist.

Apr 25: NAVSTAR Global Positioning System: Phase I: Controllable Reception Pattern Antenna program, general (RFP F04701-78-R-0040) and manpack/vehicular (RFP F04701-78-R-0041). Proposals are sought from firms which meet the requirements previously synopsisized in 2 Feb 78 *Commerce Business Daily*. R&D sources sought. Issuance date of both solicitations o/a 26 Apr 78 and responses are due in the contracting office 30 days thereafter. Headquarters, Space and Missile Systems Organization (AFSC) (PMN), PO Box 92960, Worldway Postal Center, Los Angeles CA 90009.

● **Apr 26: Design and Construction of an OTEC Seacoast Test Facility:** RFP 784406 will be issued on 28 Apr 78, responses evaluated, approvals obtained, a contract awarded, and the contract administered until the construction is completed and accepted. The RFP is for the design and construction of an OTEC Seacoast Test Facility on a cost-sharing basis, with the selected contractor providing the construction costs, at a site which would meet OTEC seawater-resource requirements and be a potential candidate for an ultimate demonstration and a commercial OTEC power plant. The facility will serve to conduct heat transfer, biofouling, corrosion, cleaning, and materials studies on heat exchangers ranging from single tubes, to small complete heat exchangers, to 1MWt "core" test units. The studies will include testing of auxiliary components such as pumps, piping, screens, valves, and cables. The cold seawater intake pipe will provide seawater with deep-ocean quality. The warm seawater intake pipe will provide the clean characteristics of open-ocean water. The laboratory is specifically intended as a "center of excellence" in OTEC and marine engineering in general. It is envisioned that scientists and engineers would use the laboratory as a sort of post-graduate school in marine technology. Plans have been initiated to eventually conduct a marine corrosion, biofouling, and materials course for interested individuals such as utility personnel. The resultant contractor(s) shall provide a suitable OTEC seacoast site with adequate supporting facilities such as roads, communications, etc. The site shall be suitable ultimately for an OTEC application. In addition to the site selection, the resultant contractor(s) shall design the cold- and warm-water pipe systems, laboratory facilities, and any necessary supporting facilities, and construct the pipe system and shore facilities. A detailed

Statement of Work is included in this Request for Proposal. A list of deliverables is also provided as a portion of the Statement of Work. Closing date 16 Jun 78. (114) Argonne National Laboratory, 9700 South Cass Avenue, Argonne IL 60439, Attn: R. Houghton, Building 4.

Apr 26: Accelerated Environmental Tests on Thermal Detection Devices: Contract N DOT-TSC-1529 (TSC/743-0009-PK), for \$40,975, to Southwest Research Institute, 8500 Culebra Road, San Antonio TX 78284.

Apr 27: Further Research on Descriptive Physical Oceanography: Contract N00014-75-C-0201, 11 Apr 78 (no RFP), for \$263,639, to Florida State University, Tallahassee FL 32306.

Apr 27: Additional Oceanographic Research to Include Physical, Chemical, and Biological Oceanography, Environmental Acoustics, Marine Geophysics, Ocean Engineering: Contract N00014-76-C-0067, 11 Apr 78 (no RFP), for \$63,000, to The State of Oregon Acting By and Through The State Board of Higher Education on Behalf of Oregon State University, Corvallis OR 97331.

● **Apr 27: Island-Wide Power System (IWPS) Stability Study, Guam Power Authority and Public Works Center, Guam, Mariana Islands:** Contract N62742-78-C-0004, 24 Mar 78, for \$52,230, to Westinghouse Electric Corp., 1030 Mapunapuna St., Honolulu HI 96819. Pacific Division, Naval Facilities Engineering Command, Pearl Harbor HI 96860.

Apr 28: Architectural Engineer Support to a Co-operative Energy Assessment for Egypt: Negotiations are being conducted with Bechtel National Inc., 50 Beale St., PO Box 3965, San Francisco CA 94119. (115)

May 1: Design a Computer Model That Will Take the Output From Existing Operational Models to Predict Detailed Distributions of Wind, Temperature, Humidity, Turbulence, and Turbulent Transport in the Lower Layers of the Atmosphere Over the Ocean and Along Coasts at Selected Locations and Times: Contract N00019-78-C-0300, 13 Apr 78 (no formal RFQ), for \$85,060, to Aeronautical Research Associates, Princeton NJ. Naval Air Systems Command, Washington DC 20361.

CONTRIBUTIONS INVITED

To add to *The OTEC Liaison's* function as an informative and useful instrument of communication, the editor invites readers to contribute. Contributions may take the form of informally-written reviews of research underway or planned, letters to the editor, or collect telephone calls. Inquiries of any sort are also invited, as we are generally well informed of OTEC progress as well as projected planning by researchers, government and private industry.