

6-9-2008

Activation of Alpha7 Subunit Containing Nicotinic Acetylcholine Receptors Mediates Cell Death of Neurons in the Avian Ciliary Ganglion

Martin Hruska
University of Vermont

Follow this and additional works at: <http://scholarworks.uvm.edu/graddis>

Recommended Citation

Hruska, Martin, "Activation of Alpha7 Subunit Containing Nicotinic Acetylcholine Receptors Mediates Cell Death of Neurons in the Avian Ciliary Ganglion " (2008). *Graduate College Dissertations and Theses*. Paper 112.

This Dissertation is brought to you for free and open access by the Dissertations and Theses at ScholarWorks @ UVM. It has been accepted for inclusion in Graduate College Dissertations and Theses by an authorized administrator of ScholarWorks @ UVM. For more information, please contact donna.omalley@uvm.edu.

**ACTIVATION OF ALPHA7 SUBUNIT CONTAINING NICOTINIC
ACETYLCHOLINE RECEPTORS MEDIATES CELL DEATH OF NEURONS IN
THE AVIAN CILIARY GANGLION**

A Dissertation Presented

by

Martin Hruska

to

The Faculty of the Graduate College

of

The University of Vermont

In Partial Fulfillment of the Requirements
for the Degree of Doctor of Philosophy
Specializing in Anatomy and Neurobiology

February, 2008

Accepted by the Faculty of the Graduate College, The University of Vermont, in partial fulfillment of the requirements for the degree of Doctor of Philosophy, specializing in Anatomy and Neurobiology

Dissertation Examination Committee:

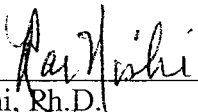

Rae Nishi, Ph.D. Advisor

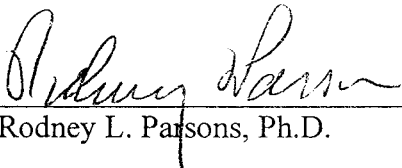

Rodney L. Parsons, Ph.D.

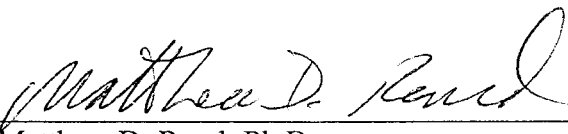

Matthew D. Rand, Ph.D.

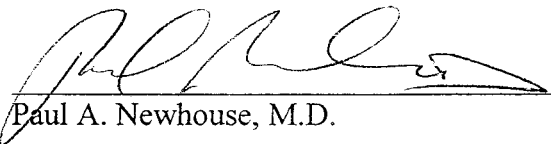

Paul A. Newhouse, M.D. Chairperson

Frances E. Carr, Ph.D. Vice President for the Research and
Dean of the Graduate College

Date: October 18, 2007

ABSTRACT

Programmed cell death is a widespread phenomenon in the developing nervous system. During early development, neurons are initially produced in excess and up to 70% of them are eliminated in later stages of development, during a period of synapse formation with their targets. However, the mechanisms that initiate the death of neurons are not clear. In the avian ciliary ganglion, neurons go through the period of target-dependent cell loss between E8 and E14; however, almost all neurons in the ganglion are prevented from dying by the chronic *in ovo* treatment with $\alpha 7$ -nAChRs specific antagonists, α -bungarotoxin or MLA. Since $\alpha 7$ -nAChRs are implicated in the cell death of ciliary ganglion neurons, I tested whether the activation of these receptors directly on the ciliary ganglion neurons facilitates cell death by inducing large increases in intracellular Ca^{2+} . I found that the ciliary ganglion neurons are heterogeneous with respect to their surface $\alpha 7$ -nAChR density and, as a result, activation of these receptors by nicotine leads to large increases in $[\text{Ca}^{2+}]_i$ in some neurons but not in others. Furthermore, immature E8 neurons exhibit slower rates of Ca^{2+} decay after nicotine stimulation than E13 neurons, suggesting that E8 neurons do not clear $[\text{Ca}^{2+}]_i$ efficiently and could be more susceptible to Ca^{2+} overload. Expressing the α btx that is tethered to the cell membrane via the glycosylphosphatidylinositol anchor (GPI α btx) in the ciliary ganglion neurons inhibits the increases in $[\text{Ca}^{2+}]_i$ induced by nicotine through $\alpha 7$ -nAChRs specifically. This cell-autonomous inhibition of $\alpha 7$ -nAChRs prevents cell death of ciliary and choroid neurons. For this to happen, GPI α btx must be expressed in neurons; the expression of this construct in the surrounding non-neural tissue does not prevent neuronal loss in the ciliary ganglion. Later in development, $\alpha 7$ -nAChRs are prevented from inducing cell death by the chicken PSCA molecule that is significantly upregulated in the ciliary ganglion between E8 and E15. The chicken PSCA is neuronal specific molecule that belongs to the Ly-6/neurotoxin superfamily that includes α btx and lynx1 and compared to other tissues, it is highly expressed in the ciliary ganglion. The expression of the PSCA mRNA in tissues correlates with the expression of $\alpha 7$ -nAChR mRNA, suggesting that PSCA modulates the signaling via these receptors. In fact, overexpressing the PSCA in the ciliary ganglion neurons prevents nicotine-induced increases in $[\text{Ca}^{2+}]_i$ through $\alpha 7$ -nAChRs. Misexpressing the PSCA in E8 ciliary ganglion prevents choroid but not ciliary neurons from dying. Therefore afferent inputs can induce cell death by activation of $\alpha 7$ -nAChRs in the developing ciliary ganglion by increasing the $[\text{Ca}^{2+}]_i$ over the threshold for cell death. Upregulation of endogenous prototoxins, such as PSCA, opposes the large increases in $[\text{Ca}^{2+}]_i$ via $\alpha 7$ -nAChRs and prevents these channels from facilitating cell death after the final numbers of neurons have been established. These results indicate that the control of cell death is more complex than originally proposed by the neurotrophic hypothesis and present the mechanism by which cell death in the developing ciliary ganglion is regulated, thus, further highlighting the importance of non-traditional roles of $\alpha 7$ -nAChRs during the development of the nervous system.

CITATIONS

Material from this dissertation has been published in the following form:

Hruska, M. and Nishi, R. (2007). Cell-Autonomous Inhibition of $\alpha 7$ Containing Nicotinic Acetylcholine Receptors Prevents Death of Parasympathetic Neurons during Development. *J. Neurosci.* 27 (43): 11501-11509.

ACKNOWLEDGEMENTS

I would like to express the sincerest gratitude to Dr. Rae Nishi for being an amazing advisor and mentor. Besides teaching me how to be a responsible scientist, I cannot thank you enough for giving me the opportunity to teach at the MBL where I truly learned what science is all about and where I got a chance to meet other great scientists in the field of neuroscience. Thank you for the hard work that you put into my training; you are the role model that I will look up to for the rest of my scientific career. I would also like to thank the members of my committee, Dr. Rodney L. Parsons, Dr. Matthew D. Rand and Dr. Paul A. Newhouse, for their guidance during my graduate work. Your invaluable advice and experience helped me to carry this project to completion.

I would also like to thank my family, my parents Viera and Stefan and my sister Eva. Thank you for stressing the importance of education and making numerous sacrifices, which allowed me to reach the goals that I set for myself. It would never be possible without your unconditional support.

Finally, I would like to thank all the members of the Department of Anatomy and Neurobiology and especially the graduate students, who made my time here so enjoyable. A special thanks to Sue Buckingham, Eric Krauter, Matt Maneen, and John Tompkins who over the years became my closest friends. You made my time in graduate school so much fun and gave me the support I needed when the times were tough. I would be so lucky to work with people like you in my next scientific life.

TABLE OF CONTENTS

CITATIONS	ii
ACKNOWLEDGEMENTS	iii
LIST OF FIGURES.....	viii
LIST OF TABLES	x

CHAPTER 1

COMPREHENSIVE LITERATURE REVIEW	1
<i>Developmental Cell Death in The Vertebrate Nervous System</i>	1
Biological Role.....	1
Error Correction.....	2
Quantitative Optimization of Connectivity (System-Matching Hypothesis).....	4
Target-Dependent Cell Death and The Neurotrophic Hypothesis	6
Afferent/Non-Target Dependent Cell Death.....	9
Calcium Set-Point Hypothesis.....	11
Cholinergic Agents	14
<i>Nicotinic Acetylcholine Receptors</i>	15
Neuronal Nicotinic Acetylcholine Receptors.....	16
$\alpha 7$ Subunit Containing nAChRs.....	19
Presynaptic $\alpha 7$ -nAChRs	20
Postsynaptic $\alpha 7$ -nAChRs.....	21

The function of $\alpha 7$ -nAChRs during development.....	22
<i>The Avian Ciliary Ganglion As a Model System</i>	28
Nicotinic Acetylcholine Receptors in the Ciliary Ganglion	30
Developmental Cell Death in the Ciliary Ganglion.....	34
<i>Aims of This Dissertation</i>	36
LITERATURE CITED.....	39

CHAPTER 2

CELL-AUTONOMOUS INHIBITION OF $\alpha 7$ CONTAINING NICOTINIC ACETYLCHOLINE RECEPTORS PREVENTS DEATH OF PARASYMPATHETIC NEURONS DURING DEVELOPMENT	68
ABSTRACT.....	69
INTRODUCTION.....	70
MATERIALS AND METHODS.....	73
RESULTS	80
<i>Immature ciliary ganglion neurons express heterogeneous levels of $\alpha 7$-nAChRs</i>	80
<i>Membrane-tethered α-bungarotoxin inhibits $\alpha 7$-nAChR mediated Ca^{2+} influx in ciliary ganglion neurons</i>	84
<i>GPIαbtx rescues ciliary and choroid neurons from cell death</i>	86
DISCUSSION.....	88
REFERENCES.....	94

CHAPTER 3

PROSTATE STEM CELL ANTIGEN IS AN ENDOGENOUS PROTOTOXIN THAT
ANTAGONIZES ALPHA 7 CONTAINING NICOTINIC RECEPTORS AND
PREVENTS PROGRAMMED CELL DEATH OF PARASYMPATHETIC NEURONS
..... 118

SUMMARY 119

INTRODUCTION..... 120

RESULTS 124

Identification of chicken lynx sequences..... 124

Expression pattern of chicken PSCA..... 125

PSCA blocks activation of $\alpha 7$ nAChRs and rescues choroid neurons from cell death
 128

DISCUSSION 131

SUPPLEMENTAL MATERIAL 136

EXPERIMENTAL PROCEDURES 137

REFERENCES..... 143

FIGURE LEGENDS 152

TABLES 164

CHAPTER 4

SUMMARY AND CONCLUSIONS..... 166

Significance of the results..... 168

<i>Future Directions</i>	175
COMPREHENSIVE BIBLIOGRAPHY	179

LIST OF FIGURES

CHAPTER 1:

Figure 1. Classic model of the neurotrophic hypothesis.....	7
Figure 2. Calcium set point hypothesis.....	13
Figure 3. Structure of the neuronal nicotinic acetylcholine receptors.....	18
Figure 4. Location of targets in the avian ciliary ganglion.....	29
Figure 5. Nicotinic acetylcholine receptors in the ciliary ganglion.	31
Figure 6. Cell death in the ciliary ganglion.....	35

CHAPTER 2:

Figure 1. Cell surface $\alpha 7$ -nAChRs on developing ciliary ganglion neurons.....	104
Figure 2. Calcium influx through $\alpha 7$ -nAChRs during ciliary ganglion development...	106
Figure 3. GPI α btx expression in ciliary ganglion neurons after injection with RCASBP(A) retrovirus.	108
Figure 4. The majority of GPI α btx is not released from cell membranes.....	110
Figure 5. Cell-autonomous inhibition with GPI α btx rescues ciliary ganglion neurons from cell death.....	112
Figure 6. Presynaptic $\alpha 7$ -nAChRs from AON are unlikely to mediate death of ciliary ganglion neurons	114
Supplementary Figure 1. Specificity of rabbit anti- α btx.....	116

CHAPTER 3:

Figure 1. Expression of molecules with homologies to the Ly6/Neurotoxin superfamily
in chicken ciliary ganglion..... 152

Figure 2. The *ch6Ly* is prostate stem cell antigen..... 154

Figure 3. Quantification of PSCA transcript expression 156

Figure 4. Misexpression of chicken PSCA using RCASBP(A) retrovirus..... 158

Figure 5. Overexpression of PSCA at E8 blocks nicotine-induced calcium influx via $\alpha 7$ -
nAChRs..... 160

Figure 6. Misexpression of PSCA rescues choroid, but not ciliary neurons 162

CHAPTER 4:

Figure 1. A model of cell death in the ciliary ganglion..... 167

LIST OF TABLES

Supplemental Table 1. Chicken lynx specific sequence primer	136
Supplemental Table 2. Chicken-specific real-time PCR primers and probes	136
Table 1. Relative real-time PCR quantification of transcripts in tissues from E15 chicken embryos.....	164
Table 2. Relative real-time PCR quantification of PSCA transcript in adult mouse tissue	165

CHAPTER 1

COMPREHENSIVE LITERATURE REVIEW

Developmental Cell Death in The Vertebrate Nervous System

Biological Role

Programmed cell death is a widespread phenomenon in the developing nervous system. Nearly all classes of neurons are produced during development in numbers greater than that found in the adult nervous system, only to be partially eliminated later in development (Cowan et al., 1984). Depending on the region of the nervous system, 20% - 70% of neurons are eliminated by a highly regulated process known as programmed cell death. This phenomenon is conserved throughout evolution (Ameisen, 1996) and involves activation of specific cell death genes (Ellis and Horvitz, 1986; Kuida et al., 1996; Pettmann and Henderson, 1998). Although most studies involving developmental cell death have been done in birds and mammals, it is believed that cell death involves all major taxonomic groups and many types of neurons (motor, sensory, autonomic) in central (CNS) and peripheral (PNS) nervous systems, suggesting that it plays an important role in sculpting the gross structure of the vertebrate nervous system (Oppenheim, 1991; Buss et al., 2006). It is now recognized that many neurons are eliminated well before they contact their targets; however, the majority of neuronal cell

loss involves post-mitotic neurons and coincides with the period of target innervation (Oppenheim, 1991).

The process of developmental cell death has been extensively described (Oppenheim, 1991), but the reason for this massive neuronal cell death is still unclear. Several hypotheses for the explanation of this phenomenon have been proposed, however, only some of these received experimental support. Since the vast majority of neurons eliminated during development are terminally post-mitotic and proper nervous system function critically depends on formation of extensive and highly specific synaptic circuits, two particularly attractive hypotheses are (i) error correction and, (ii) the optimization of connectivity between neurons, their targets and afferent inputs (system matching hypothesis) (Clarke et al., 1998; Buss et al., 2006).

Error Correction

The formation of appropriate connections is critical for proper functioning of the nervous system. Therefore, it is reasonable to assume that one of the roles of developmental cell death is the elimination of aberrant connections (Cowan et al., 1984). Initial evidence for this came from studies in the isthmo-optic nucleus (ION) of chicken embryos. The axons from neurons in ION normally project to, and synapse in, the contralateral retina, however, a small number of ION neurons project to the ipsilateral retina (Clarke and Cowan, 1975, 1976). These ipsilateral projections are transient and subsequent studies showed that these incorrectly projecting ION neurons die rather than lose their ipsilateral

axons (McLoon and Lund, 1982; O'Leary and Cowan, 1982). Furthermore, in a developing chicken visual system, a number of incorrect projections from the retina of one eye to the retina of the opposite eye, as well as the projections from the retina to the ipsilateral tectal lobe, are observed. These targeting errors are eliminated in the later stages of development, during the cell death of retinal ganglion neurons (McLoon and Lund, 1982; O'Leary et al., 1983; Thanos and Bonhoeffer, 1984).

Although many of the aberrantly projecting ION neurons are eliminated during the period of cell death, they constitute less than 1% of the total ION population undergoing cell death (Clarke and Cowan, 1976). However, rather than synapsing on a completely incorrect target, it is more common for neurons to project to the wrong area of the topographically correct target. For example, in a mature rat visual system, the retino-collicular projections form a highly organized structure where neurons from the nasal part of the retina project to the caudal part of the contralateral superior colliculus (Land and Lund, 1979). In newborn animals, however, a number of neurons from the temporal part of the retina also synapse in caudal superior colliculus but the majority of these improperly projecting neurons are eliminated during the period of cell death of the retinal ganglion cells (Crespo et al., 1985; O'Leary et al., 1986). Similarly, 40% of the ION neurons synapsing in the topographically wrong area of contralateral retina are eliminated by the end of cell death in the ION, suggesting that the majority of neurons that die are the ones whose axons do not conform to the topography of the isthmo-optic projections (Catsicas et al., 1987).

The elimination of erroneous connections during the programmed cell death seems to be one of the dividends associated with a larger process of system matching (see below). Still, the mechanisms that lead to the preferential death of some neurons over others are largely unknown.

Quantitative Optimization of Connectivity (System-Matching Hypothesis)

Most of the evidence in the field of developmental cell death agrees with the hypothesis that neurons are initially overproduced so that the number of functional contacts with their cellular partners can be adjusted to provide sufficient innervation of their targets (Pettmann and Henderson, 1998). The most direct evidence for the system-matching hypothesis comes from studies in which target fields of various neuronal populations have been experimentally manipulated. In these studies, complete or partial removal of the target tissue exacerbated neuronal cell death (Hamburger, 1958; Landmesser and Pilar, 1974b; Oppenheim et al., 1978), while increasing target availability significantly reduced the number of neurons undergoing cell death (Hollyday and Hamburger, 1976; Narayanan and Narayanan, 1978b; Boydston and Sohal, 1979).

These experiments suggest that the size of the target field regulates the number of surviving neurons; however, in many instances this relationship does not appear to hold. For example, doubling the size of the target tissue does not prevent death of all neurons as would be expected according to this hypothesis, instead little less than half of cell death is prevented (Sperry and Grobstein, 1985; Tanaka and Landmesser, 1986;

Oppenheim, 1991). Similarly, complete removal of the target tissue does not result in the loss of all neurons (Tanaka and Landmesser, 1986).

The most serious challenge for the size-matching hypothesis comes from studies in *Xenopus laevis* larvae. After the removal of a hind limb and experimentally directing the axons of these motoneurons into the contralateral (surviving) limb, the number of surviving motoneurons on both sides of the spinal chord was equivalent to the control animals with both hind limbs intact (Lamb, 1980). Muscle from the single limb was able to support twice as many motoneurons. These results suggest that the cell death of motoneurons does not depend on the magnitude of the projection field but rather on some other mechanisms, unless the amount of the trophic factor produced by targets is controlled by the magnitude of its innervation (Purves, 1980). In contrast to Lamb's findings, the removal of the optic primodium and the disruption of the optic chiasm, which re-routes axons from both IONs to the surviving eye, exacerbates cell death in both IONs (O'Leary and Cowan, 1984).

Although targets seem to play an important role in regulating neuronal survival during developmental cell death, the above results indicate that the process of neuronal cell death is not a random matching of the neuronal pool to the size of the target. Multiple hypotheses have been proposed to explain the cell death of post-mitotic neurons but none of these have proven to be completely correct. Therefore, the significance of programmed cell death during development of the vertebrate nervous system is still not

understood. Moreover, the mechanisms that induce neuronal cell death during development are still unknown. It is possible that the initial overproduction of neurons and their subsequent elimination later in development sub-serves many different functions necessary for the proper functioning of the nervous system.

Target-Dependent Cell Death and The Neurotrophic Hypothesis

The observation that neuron-target interactions play an important role during the developmental cell death suggested that neurons compete for some “entity” within the target tissue and that this competition determines the fate of a neuron (Cowan et al., 1984). This line of evidence led to a discovery of the nerve growth factor (NGF) and the formulation of the neurotrophic hypothesis, which states that the neurons compete for limiting amounts of trophic molecules released by their targets and the winners of this competition survive, while the losers die by programmed cell death (Figure 1; Levi-Montalcini and Angeletti, 1968; Oppenheim, 1989, 1991; Davies, 1996). The first direct evidence for this view was the demonstration that NGF supports the survival of sympathetic and some sensory neurons *in vitro* and *in vivo*. Administration of anti-NGF antibodies during the period of target innervation eliminates these neurons while the application of exogenous NGF prevents cell death of the same population of neurons (Levi-Montalcini and Angeletti, 1968; Johnson et al., 1980; Hamburger and Yip, 1984; Ruit et al., 1992). Additional evidence for the neurotrophic hypothesis came from the findings that neurons in the avian ciliary ganglion can be supported *in vitro* in the presence of cultured muscle cells as well as in the medium that has been conditioned

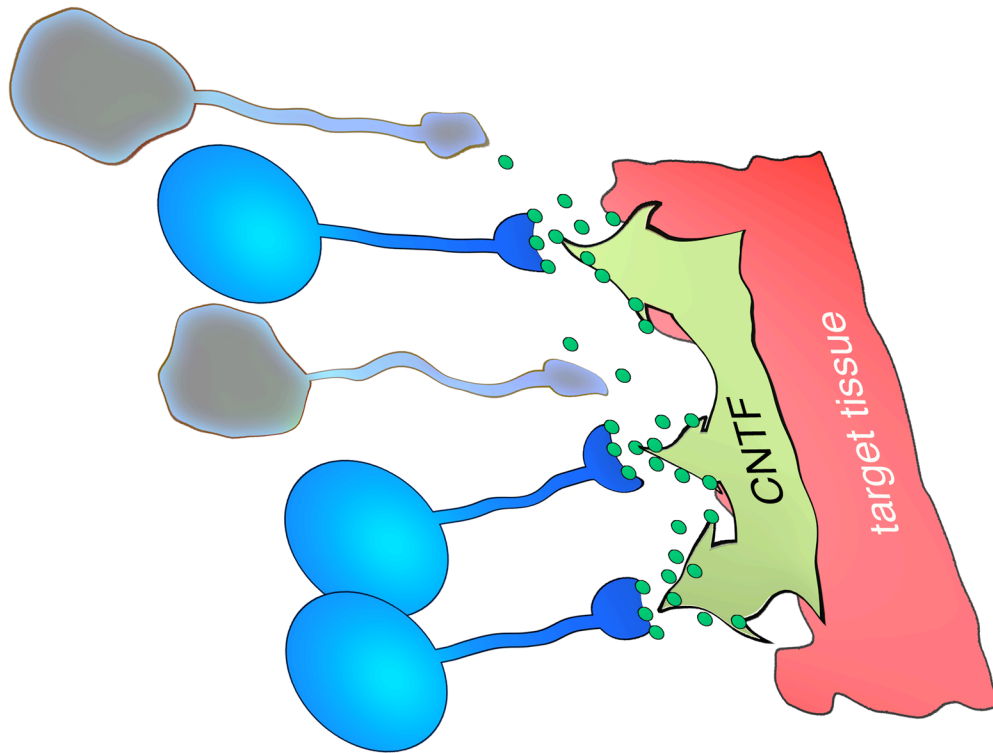

Figure 1. Classic model of the neurotrophic hypothesis.

As soon as neurons arrive to their targets, they become dependent on target-derived factors for survival. The neurotrophic hypothesis states that neuronal survival is determined based on competition for target-derived factors. The winners of this competition survive and the losers die.

by these muscle cells (Nishi and Berg, 1977, 1979). These studies together with the observation that NGF is essential for the survival of only two classes of neurons, paved the way for the discovery of additional target-derived factors, such as brain-derived neurotrophic factor (BDNF), neurotrophin-3 (NT-3) and neurotrophin-4/5 (NT-4/5; the members of the neurotrophin family), ciliary neurotrophic factor (CNTF), fibroblast growth factor and others (Barde et al., 1982; Ernfors et al., 1990; Jones and Reichardt, 1990; Berkemeier et al., 1991; Leung et al., 1992).

Additional molecular evidence supporting the neurotrophic hypothesis was provided by studies from the knockout mouse in which the deletion of genes coding for different members of neurotrophin family and their receptors exacerbated cell death of specific neuronal populations (Snider, 1994). NGF and *trkA* knockouts have dramatically reduced populations of dorsal root ganglion (DRG) neurons and virtually absent sympathetic ganglia (Crowley et al., 1994; Smeyne et al., 1994). In line with this evidence, overexpression or experimental administration of NGF prevents cell death of the same neuronal populations (nociceptive DRG neurons and sympathetic ganglia), and in turn, causes profound hyperalgesia to noxious mechanical stimuli (Davis et al., 1993). BDNF and *trkB* knockouts exhibit drastically depleted neuronal populations in vestibular ganglia and significant neuronal loss in trigeminal ganglia and DRG. However, the BDNF knockout animals exhibit more subtle phenotypes in the CNS (Ernfors et al., 1994a; Jones et al., 1994) probably due to the redundant functions of multiple trophic factors. The retrograde signaling by NT-3 seems to be responsible for the survival of

proprioceptive neurons in the PNS and the CNS, because NT-3 or *trkC* knockout animals have a significantly depleted pool of large myelinated group Ia afferents and exhibit 50% loss of proprioceptive neurons in the mesencephalic nucleus (Ernfors et al., 1994b; Klein et al., 1994).

In its original form, the neurotrophic hypotheses proposed that the survival of each neuronal population depends on the supply of a single target-derived neurotrophic factor (Davies, 1996). With the discovery of multiple neurotrophic factors, it is now recognized that certain populations of neurons require the cooperation of two or more neurotrophic factors for survival. Neurons have to integrate trophic support from glia as well as their targets (Riethmacher et al., 1997; Grieshammer et al., 1998). Furthermore, developing neurons encounter intermediate targets *en route* to their final destination with an entirely different trophic repertoire than their targets (Eisen and Melancon, 2001). These results indicate that the neurons have more complex trophic requirements than originally predicted by the neurotrophic hypothesis.

Afferent/Non-Target Dependent Cell Death

Although competition for neurotrophic factors has been central in explaining developmental cell death, afferent influences such as activity are emerging as important in controlling neuronal survival during development. The observation that afferent input is necessary for the survival of neurons has been demonstrated in studies where the deletion of presynaptic axons resulted in the widespread death of postsynaptic neurons in

the visual, olfactory, auditory sensory systems (reviewed in Linden, 1994; Mennerick and Zorumski, 2000). In addition, blocking afferent neuronal activity pharmacologically with tetrodotoxin (TTX; a voltage-gated sodium channel blocker) or colchicine (microtubule polymerization inhibitor that blocks fast axoplasmic transport) leads to an increased cell death of rat and chicken tectal neurons (Catsicas et al., 1992; Galli-Resta et al., 1993), further demonstrating the need for activity-dependent neuronal support in the developing nervous system. In the chicken auditory system, transection or electrical block of the auditory nerve causes loss of neurons in the nucleus magnocellularis, a structure analogous to a mammalian cochlear nucleus (Rubel et al., 1990). Similarly, in the PNS, deletion of the preganglionic accessory oculomotor nucleus (AON) in developing chicken embryos exacerbates cell death of the ciliary ganglion neurons (Furber et al., 1987). Altogether, these findings suggest that the inhibition or lack of excitation is directly toxic to developing neurons. Although the *in vivo* results demonstrate that the afferent input is necessary for neuronal survival, the mechanism of activity-dependent survival is not clear from these studies. Due to their accessibility, a variety of cell culture models have been used to further elucidate what this mechanism could be.

In accordance with *in vivo* results, several cell culture studies show that high K^+ or neurotransmitter-induced depolarization promotes survival of neurons without the requirement for the trophic support (Lipton, 1986; Cohen-Cory et al., 1991; Collins et al., 1991; Eichler et al., 1992; Pugh and Margiotta, 2000). Depolarization of neurons by elevating the extracellular K^+ concentration leads to an increase in intracellular Ca^{2+}

concentration ($[Ca^{2+}]_i$) through activation of the L-type voltage-gated Ca^{2+} channels (VGCC), because the survival promoting effect of K^+ can be blocked by dihydropyridines like nifedipine or nitrendipine (Collins and Lile, 1989). However, other means of raising $[Ca^{2+}]_i$, such as thapsigargin-induced Ca^{2+} release from internal stores, can substitute for the activation of VGCC (Lampe et al., 1995). Therefore, it is likely that the increases in $[Ca^{2+}]_i$ by activity-dependent mechanisms support survival by a Ca^{2+} -dependent gene regulation or posttranscriptional modifications of proteins.

Calcium Set-Point Hypothesis

Calcium is a ubiquitous second messenger that can affect a variety of intracellular events. Furthermore, Ca^{2+} overload has been suggested to be the final common pathway to all types of cell death (Berridge et al., 2003; Hajnoczky et al., 2003). Based on the work with cell culture models, specifically sympathetic neurons, the calcium set point hypothesis has been proposed to explain the relationship between the activity-dependent survival and neurotrophic factor dependence (Koike et al., 1989; Johnson et al., 1992). In these studies, sympathetic neurons deprived of NGF were protected from cell death in a dose-dependent manner if grown in a culture medium containing elevated K^+ concentrations (15-30 mM). Potassium concentrations that resulted in a partial survival of NGF-deprived sympathetic neurons caused smaller increases in $[Ca^{2+}]_i$ than the concentrations of K^+ that prevented cell death of all neurons. Furthermore, the age-dependent reduction of NGF requirement by sympathetic neurons is associated with an increase in the resting calcium levels (Koike and Tanaka, 1991). Therefore, according to

the Ca^{2+} set point hypothesis, in the absence of neurotrophic factors, modest elevations in $[\text{Ca}^{2+}]_i$ are protective. When the $[\text{Ca}^{2+}]_i$ is driven to low levels not conducive to survival, neurotrophic factors can protect neurons from dying. However, if the $[\text{Ca}^{2+}]_i$ is driven too high for a long period of time, excitotoxicity or Ca^{2+} -dependent apoptosis ensues and neurons can no longer be rescued from dying by neurotrophic factors (Figure 2; Koike et al., 1989; Johnson et al., 1992; Mennerick and Zorumski, 2000).

Although it is well accepted that in many neuropathological conditions in the mature nervous system, the large increases in $[\text{Ca}^{2+}]_i$ and subsequent Ca^{2+} excitotoxicity result from excessive activation of NMDA receptors by glutamate (Zorumski and Olney, 1993; Choi, 1994), in the developing nervous system, increases in $[\text{Ca}^{2+}]_i$ are usually protective. However, studies in developing chicken nucleus magnocellularis indicate that activation of metabotropic glutamate receptors (mGluRs) by glutamate can diminish apoptosis-inducing rises in $[\text{Ca}^{2+}]_i$ that result from high spontaneous firing levels in magnocellularis neurons (Lachica et al., 1998). This provides a clear example that conventional neurotransmitters regulate survival of neurons by controlling the levels of $[\text{Ca}^{2+}]_i$ during development of the vertebrate nervous system.

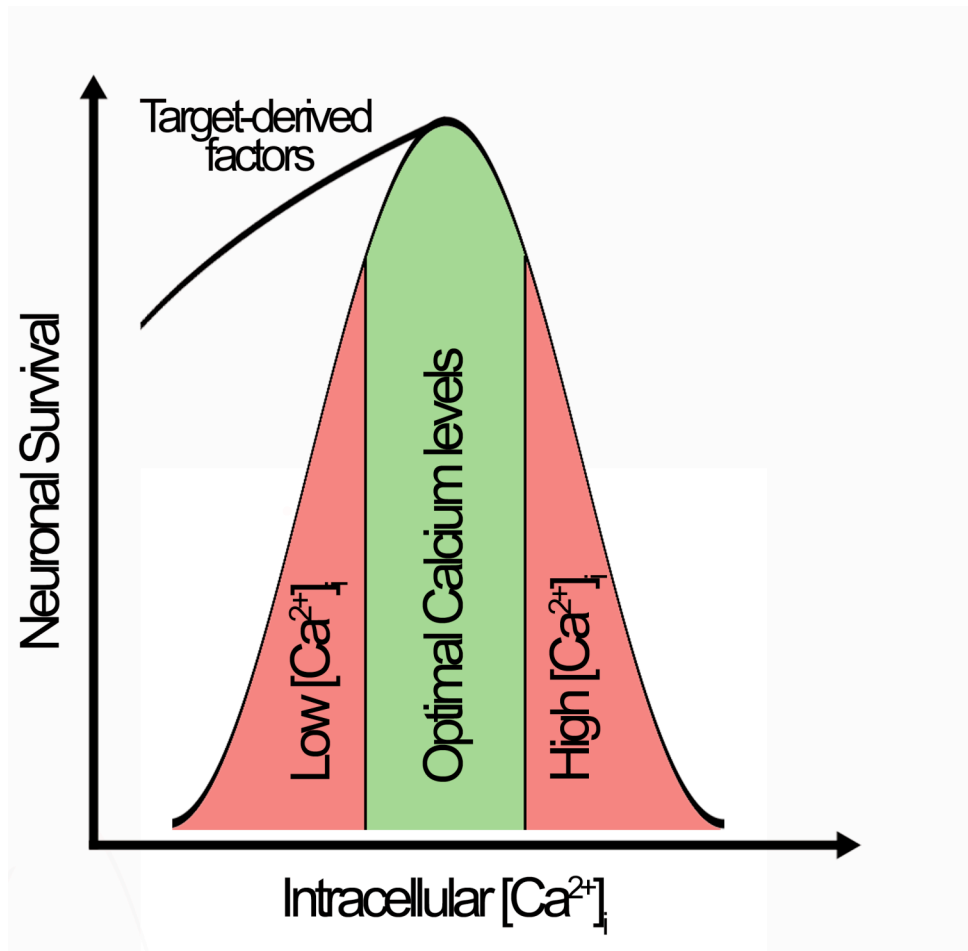

Figure 2. Calcium set point hypothesis.

Depolarization of neurons with high extracellular K^+ or postsynaptic receptor stimulation supports neuronal survival without the requirement for trophic factors. According to this theory, optimal levels of $[Ca^{2+}]_i$ promote survival without the requirement for neurotrophic factors. Raising or decreasing the $[Ca^{2+}]_i$ and moving it away from the optimal Ca^{2+} set point leads to cell death. Trophic factors protect neurons against low $[Ca^{2+}]_i$ but they are unable to protect neurons when the $[Ca^{2+}]_i$ rises to the levels high enough to reach the threshold for cell death. (Adapted from Mennerick and Zorumski, 2000).

Cholinergic Agents

The blockade of neuromuscular transmission with cholinergic antagonists, such as curare or α -bungarotoxin (α btx), has the opposite effect from that of TTX or colchicine: it prevents cell death of motoneurons. In fact, treatment of embryos with agents that block neuromuscular transmission is the most effective way of preventing spinal cord motoneurons from dying. These manipulations prevent cell death of more than 60% of neurons normally destined to die (Pittman and Oppenheim, 1979). Because the treatment of embryos with curare or α btx increases the axonal branching of motoneurons as well as the number of synaptic contacts with the targets (demonstrated by an increased number of nAChR clusters), it has been proposed that the motoneurons survive because they have increased access to target-derived neurotrophic factors (Dahm and Landmesser, 1988; Landmesser, 1992; Usiak and Landmesser, 1999).

Although it is assumed that cholinergic antagonists prevent cell death of motoneurons by blocking peripheral neuromuscular transmission, they may also act by blocking nAChRs at centrally located synapses in the spinal cord (Landmesser and Szente, 1986). Evidence supporting this hypothesis comes from studies in which embryos treated with the subparalytic doses of α btx still exhibit a significantly larger number of spinal motoneurons compared to the saline treated embryos (Hory-Lee and Frank, 1995). Furthermore, treatment of *crooked neck* chicken embryos, which are already paralyzed due to the naturally occurring mutation in the ryanodine receptor with curare or α btx, prevents the cell death of a significant number of motoneurons (Oppenheim et al., 2000).

These results suggest that the cessation of neuromuscular transmission cannot be entirely responsible for the prevention of naturally occurring motoneuron cell death. In line with these observations, chronic treatment of embryos with α btx or α -methyllycaconitine (MLA), the α 7-nAChR-specific antagonists, prevents cell death of ciliary ganglion neurons, without accompanying changes at the target tissues, such as increase in branching or synaptogenesis (Meriney et al., 1987; Bunker and Nishi, 2002). These results implicate activation of α 7-nAChRs in facilitating cell death of ciliary ganglion neurons.

Altogether, the above evidence indicates that activity (afferent or neuromuscular) plays an essential role during programmed cell death of neurons; however, signaling via the nAChRs is complex and can either induce or prevent neuronal cell death, depending on their anatomical and cellular location, their subunit composition as well as cellular context. These results further point out that the mechanisms underlying the induction of developmental cell death are not well understood.

Nicotinic Acetylcholine Receptors

Nicotinic acetylcholine receptors (nAChRs) belong to the superfamily of ligand-gated ion channels that includes GABA_A, glycine and 5-HT₃ serotonin receptors (McGehee and Role, 1995; Dani, 2001). Although these receptors exhibit great diversity due to many different combinations of subunits composing functional nAChRs, they also share some

basic features. They occupy three main functional states – closed, open and desensitized. Brief exposure to high concentrations of the neurotransmitter acetylcholine (ACh) causes the opening of these receptors, quickly followed by their desensitization (reviewed in Dani and Bertrand, 2007). Due to their great diversity, nAChRs appear to play fundamental roles in synaptic plasticity and are involved in attention, learning, memory, and development (Role and Berg, 1996a). Disruptions in nAChRs signaling have been implicated in a variety of dysfunctions, such as schizophrenia, epilepsy, autism, Alzheimer's disease and addiction (Lena and Changeux, 1998; Picciotto and Zoli, 2002; Gotti and Clementi, 2004).

Neuronal Nicotinic Acetylcholine Receptors

Neuronal nAChRs are assembled from five transmembrane subunits arranged around a central water-filled pore (Figure 3; Karlin, 2002). To date, twelve genes that code for the neuronal nAChR subunits have been identified; nine are designated α -type ($\alpha 2$ - $\alpha 10$) and three as β -type ($\beta 2$ - $\beta 4$). Neuronal subunits that form the heteromeric nAChRs include $\alpha 2$ - $\alpha 6$ and $\beta 2$ - $\beta 4$. The $\alpha 7$, $\alpha 8$ and $\alpha 9$ subunits give rise to the homo-pentameric nAChRs, which are blocked by nanomolar concentrations of α btx (Role and Berg, 1996a; Broide and Leslie, 1999). The $\alpha 9$ subunit can also form heteromers with the $\alpha 10$ subunit (Dani and Bertrand, 2007). Heterologous expression studies in *Xenopus* oocytes show that many of the α and β subunits co-assemble to form functional nAChRs with a variety of biophysical and pharmacological properties (Sargent, 1993; McGehee and Role,

1995). Compared to other ligand-gated channels, all nAChRs have a high relative permeability to Ca^{2+} and their opening probability is modulated by external Ca^{2+} (Role and Berg, 1996a). Of all the nAChRs, homomers composed of $\alpha 7$ subunits have the highest permeability to Ca^{2+} , equal to that of NMDA receptors (Castro and Albuquerque, 1995; Rogers and Dani, 1995).

Although distinct functional nAChRs have been identified based on their biophysical and pharmacological properties, they fall into two major categories: α btx insensitive nAChRs and α btx sensitive nAChRs. The most abundant nAChR species in the CNS is made up of $\alpha 4$ and $\beta 2$ subunits. These nAChRs account for most of the high affinity nicotine labeling and assemble with two-to-three of $\alpha 4$: $\beta 2$ ratio (Wada et al., 1989; Anand et al., 1991; Flores et al., 1992; Zoli et al., 1998). These α btx insensitive nAChRs are mostly found in the nigrostriatal and mesolimbic pathways where they modulate the release of dopamine (Charpantier et al., 1998; Sorenson et al., 1998). However, $\alpha 4$ / $\beta 2$ nAChRs are not found in the PNS (Listerud et al., 1991). Of the homomeric nAChRs, only $\alpha 7$ -nAChRs are widely distributed in the CNS as well as in the PNS. These receptors account for most of the high affinity α btx binding, display high Ca^{2+} permeability and desensitize rapidly (Schoepfer et al., 1990; Bertrand et al., 1993; Vernallis et al., 1993; Zhang et al., 1994). The third major group of nAChRs is found primarily in the autonomic ganglia and is composed of $\alpha 3$, $\alpha 5$, $\beta 4$, and sometimes, $\beta 2$ subunits (Listerud et al., 1991; Vernallis et al., 1993). These nAChRs belong to the α btx insensitive class

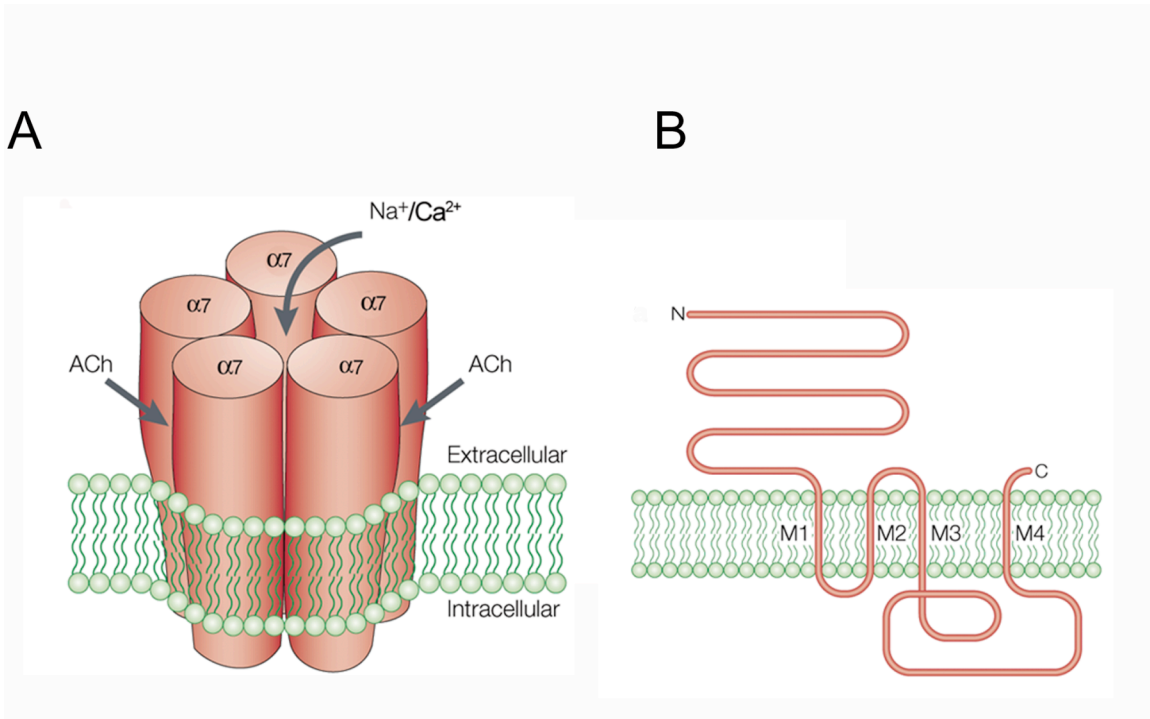

Figure 3. Structure of the neuronal nicotinic acetylcholine receptors.

Neuronal nAChRs are ligand-gated ion channels activated by ACh *in vivo*. (A) Each nAChR consists of five subunits arranged in a circular manner, forming a central water-filled pore. The activation of nAChRs by ACh or nicotine causes opening of the pore, the influx of Na^+ and Ca^{2+} and the efflux of K^+ ions. (B) Each subunit contains a large extracellular N-terminal domain with the ACh binding site, four transmembrane domains and a small extracellular C-terminal domain. (Adapted from Karlin, 2002).

and are found in the postsynaptic densities (PSD) where they mediate fast excitatory synaptic transmission (Jacob et al., 1986). Other subunits expressed in both the CNS and the PNS are much less abundant. Individual neurons commonly express more than one subtype of nAChRs depending on which gene products they express. By forming different subunit combinations, neurons can produce a large number of nAChR subtypes (Role and Berg, 1996a).

$\alpha 7$ Subunit Containing nAChRs

One of the most abundant nAChRs in the nervous system are the homo-pentamers composed of $\alpha 7$ subunits. These receptors display a relatively low affinity for ACh with half-activation at $\sim 200 \mu\text{M}$. Furthermore, $\alpha 7$ -nAChRs desensitize rapidly following agonist stimulation but due to their low affinity for the agonist, $\alpha 7$ -nAChRs are not effectively desensitized by agonist concentrations below $1 \mu\text{M}$ (Dani et al., 2000; Woollorton et al., 2003; Dani and Bertrand, 2007). Another important feature of $\alpha 7$ -nAChRs is their inward current rectification for transmembrane potentials above -40 mV (Forster and Bertrand, 1995). Due to this inward rectification and high relative Ca^{2+} permeability, $\alpha 7$ -nAChRs can induce large increases in $[\text{Ca}^{2+}]_i$ at rest or at hyperpolarized potentials. This is unlike NMDA receptors, which require depolarization to cause an elevation in $[\text{Ca}^{2+}]_i$. Therefore, $\alpha 7$ -nAChRs are well suited for the regulation of a variety of Ca^{2+} -dependent downstream signaling events (Broide and Leslie, 1999; Berg and Conroy, 2002).

Presynaptic $\alpha 7$ -nAChRs

It has been well demonstrated that nAChRs in the vertebrate neuromuscular junction as well as in the autonomic ganglia are concentrated in the PSD, where they mediate fast excitatory postsynaptic transmission; however, the situation in the CNS is a little different. Because of their high Ca^{2+} permeability and rapid desensitization, $\alpha 7$ -nAChRs are largely found at presynaptic terminals, where they regulate the extent of neurotransmitter release. This was first demonstrated in the hippocampus (Gray et al., 1996) and the interpeduncular nucleus (McGehee et al., 1995), where the application of nicotine in the presence of TTX enhanced the release of glutamate, an effect that was blocked by αbtx . The activation of presynaptic $\alpha 7$ -nAChRs is now known to modulate the release of ACh, dopamine, norepinephrine, serotonin and GABA (Lapchak et al., 1989; Vidal and Changeux, 1989; King, 1990; Lena et al., 1993; Summers and Giacobini, 1995). These functional studies were corroborated by immunogold labeling, which demonstrated the presence of $\alpha 7$ subunits in the CA1 region of a rat hippocampus, where they were located on both the GABAergic and the glutamatergic presynaptic terminals (Fabian-Fine et al., 2001).

Presynaptic $\alpha 7$ -nAChRs also modulate a neurotransmitter release in the PNS. In the ciliary ganglion, the activation of $\alpha 7$ -nAChRs on the presynaptic calyces leads to enhanced release of ACh from presynaptic terminals, creating a positive feedback loop (Coggan et al., 1997; Rogers and Sargent, 2003). Interestingly, unlike conventional $\alpha 7$ -nAChRs, these presynaptic receptors display little desensitization, which could be due to

a low concentration of ACh reaching the presynaptic terminal (Zhang et al., 1994). Alternatively, the presynaptic receptors containing $\alpha 7$ subunits may differ from the homomeric $\alpha 7$ -nAChRs in their subunit composition. Heterologous expression studies showed that co-expression of $\alpha 7$ and $\beta 2$ subunits can form a functional nAChR channel with diminished rates of desensitization (Khiroug et al., 2002). Although $\alpha 7/\beta 2$ receptors have not been found *in situ*, there are reports of slowly desensitizing $\alpha 7$ -nAChRs (Cuevas and Berg, 1998; Yu and Role, 1998). Therefore, the distinct subunit composition of nAChRs may serve as a signal for targeting nAChRs to different cellular locations (presynaptic vs. somatodendritic; Berg and Conroy, 2002).

Postsynaptic $\alpha 7$ -nAChRs

The vast majority of postsynaptic nAChRs are found in the autonomic ganglia but some are also found in the CNS. In fact, $\alpha 7$ -nAChRs generate significant postsynaptic currents in the hippocampus and the ciliary ganglion (Zhang et al., 1996; Ullian et al., 1997; Frazier et al., 1998). In both of these structures, $\alpha 7$ -nAChRs are excluded from the PSDs on neurons. Specifically, in the ciliary ganglion, the majority of $\alpha 7$ -nAChRs are concentrated on the somatic spines and are absent from PSDs (Jacob and Berg, 1983; Horch and Sargent, 1995; Shoop et al., 1999b; Shoop et al., 2002). Because PSDs and somatic spines on ciliary neurons are overlaid by a large presynaptic calyx, even these extrasynaptically-located $\alpha 7$ -nAChRs are readily exposed to ACh (Shoop et al., 1999b; Shoop et al., 2002). This is corroborated by the presence of large evoked synaptic

currents generated by $\alpha 7$ -nAChRs and the contribution of $\alpha 7$ -nAChRs to the miniature postsynaptic currents (Zhang et al., 1996; Chang and Berg, 1999).

In the hippocampus, immunogold labeling revealed that $\alpha 7$ -nAChRs are indeed located on the postsynaptic sites. However, these sites represent non-cholinergic synapses because they include nearly all recognizable synapses in the CA1 stratum radiatum of the rat hippocampus (Fabian-Fine et al., 2001), and therefore, represent either GABAergic or glutamatergic synapses. In fact, postsynaptic clusters of $\alpha 7$ -nAChR co-distribute with GABA_A receptor clusters on hippocampal neurons in culture (Kawai et al., 2002). Similarly, in a rat somatosensory cortex, an ultrastructural analysis has demonstrated the presence of postsynaptic $\alpha 7$ -nAChRs on glutamatergic synapses (Levy and Aoki, 2002). Although these $\alpha 7$ -nAChRs are located in postsynaptic locations on GABAergic and glutamatergic neurons *in vivo* and *in vitro*, they are viewed as perisynaptic at these loci, and, as such, positioned effectively for the modulation of non-cholinergic synapses (Berg and Conroy, 2002).

The function of $\alpha 7$ -nAChRs during development

The early presence of the machinery for synthesizing ACh and the transcripts for the specific nAChR subunits suggests that the nAChRs play an important role during development of the nervous system. Furthermore, expression of $\alpha 7$ -nAChRs is highly regulated in the developing CNS during critical periods of synaptic plasticity. In both

rodents and chicken, $\alpha 7$ subunit mRNA and protein are highly expressed in the developing brain (Wang and Schmidt, 1976; Couturier et al., 1990; Broide et al., 1995), with a subsequent reduction in many brain regions during the postnatal development (Fiedler et al., 1990; Bina et al., 1995; Broide et al., 1995). Given the high Ca^{2+} permeability of these channels and the fact that the varying levels of $[\text{Ca}^{2+}]_i$ can have diverse effects on developing neurons, from altering gene expression to apoptosis, $\alpha 7$ -nAChRs can influence many aspects of neuronal differentiation in the developing nervous system.

Spontaneous nicotinic activity arises early in development and often occurs in bursts or waves traveling through the tissue. In the retina and the spinal cord, spontaneous nicotinic activity has been shown to direct synapse formation (Feller et al., 1996; Bansal et al., 2000; Hanson and Landmesser, 2003), demonstrating that early activation of nAChRs is important for the formation of neural circuits. In line with this evidence, the inhibition of $\alpha 7$ -nAChRs by αbtx modulates development and maintenance of retinotectal connections in the toad optic tectum (Freeman, 1977). Furthermore, pulses of ACh or nicotine applied to growing neurites in cultured ciliary ganglion neurons induce neurite retraction, a Ca^{2+} -dependent effect that is blocked by nanomolar concentrations of αbtx (Pugh and Berg, 1994). In contrast, activation of $\alpha 7$ -nAChRs leads to neurite elongation in cultured rat olfactory bulb neurons (Coronas et al., 2000). Therefore, depending on diverse neuronal cell types and the Ca^{2+} -sensitive intracellular signaling machinery, $\alpha 7$ -nAChRs can have opposing effects in developing neurons. In addition,

when septal explants are co-cultured with hippocampal slices, the filopodia of the hippocampal neurons become co-innervated by cholinergic and GABAergic terminals. This convergence of input depends on the $\alpha 7$ -nAChRs signaling, because a three day blockade of these receptors with α btx reduces the degree of cholinergic innervation, while GABAergic innervation remains unchanged (Kawai et al., 2002; Zago et al., 2006). Altogether, above evidence suggests that the activation of $\alpha 7$ -nAChRs in the developing nervous system can lead to the formation of neuronal circuitry through Ca^{2+} -dependent mechanisms.

One of the most important aspects of $\alpha 7$ -nAChR signaling at the cellular level is regulation of gene expression. Like NMDA receptors, $\alpha 7$ -nAChRs associate with PDZ scaffolding proteins such as PSD-95 that tether them to specific downstream signaling molecules, on which diverse Ca^{2+} signaling outcomes critically depend (Conroy et al., 2003; Berg et al., 2006). In ciliary ganglion neurons, increases in $[\text{Ca}^{2+}]_i$ via $\alpha 7$ -nAChRs induce long term phosphorylation of CREB (calcium and cAMP-responsive transcription factor) through the activation of CaMKII/IV and MAPK pathways. Interestingly, the coincident activation of voltage-gated calcium channels (VGCC) prevents this prolonged CREB phosphorylation (Chang and Berg, 2001b). Therefore, the activation of $\alpha 7$ -nAChRs, independent of VGCC, leads to activity-dependent gene regulation, which can have important consequences for the modulation of neuronal circuits as well as other developmental processes. In fact, endogenous nicotinic activity determines when GABAergic signaling converts from excitation (important for integration of neurons into

circuits) to inhibition (seen in the mature nervous system) during development by changing the chloride gradient across the membrane (Liu et al., 2006). The results from this study indicate that the inhibition of $\alpha 7$ -nAChRs with MLA or α btx prevents expression of the mature chloride transporter (KCC2) in both ciliary ganglion and hippocampal neurons, while expression of the immature chloride transporter (NKCC1) is retained. This in turn causes retention of the excitatory GABAergic response (Liu et al., 2006). Since $\alpha 7$ -nAChR activation induces CREB phosphorylation only in the absence of VGCC activation, the inhibitory GABAergic responses help $\alpha 7$ -nAChRs activate CREB in mature neurons by maintaining a negative membrane potential in order to prevent activation of VGCC (Chang and Berg, 2001b; Liu et al., 2006). Finally, regulation of KCC2 expression by nicotinic signaling has profound consequences on further maturation of circuits, because inhibitory GABAergic signaling induces unipolarity (seen in mature ciliary ganglion neurons *in vivo*) and restricts the innervation of ciliary ganglion neurons in culture (Liu et al., 2006).

Consistent with the control of gene expression during development, the activation of $\alpha 7$ -nAChRs has been shown to regulate NGF and BDNF mRNA levels in the adult rat hippocampus (Freedman et al., 1993). Calcium influx via $\alpha 7$ -nAChRs activates a variety of second messenger pathways, evidenced by release of the arachidonic acid in ciliary ganglion neurons (Vijayaraghavan et al., 1995), activation of Ca^{2+} /Calmodulin protein kinase and regulation of c-fos expression in PC12 cells (Greenberg et al., 1986).

Furthermore, the stimulation of $\alpha 7$ -nAChRs induces the proliferation of neuroendocrine cell lines (Quik et al., 1994).

Because Ca^{2+} is one of the key regulators of cell survival, $\alpha 7$ -nAChRs have also been implicated in controlling survival of the developing neurons. Much of *in vivo* and *in vitro* evidence indicates that nicotine is neuroprotective especially for neurons that are exposed to ischemic or toxic insults and the majority of the neuroprotective effects are attributed to $\alpha 7$ -nAChRs (Picciotto and Zoli, 2002). For example, the pre-activation of $\alpha 7$ -nAChRs protects mouse neonatal cortical neurons in culture from NMDA induced Ca^{2+} excitotoxicity (Carlson et al., 1998). In contrast, the activation of $\alpha 7$ -nAChRs by nicotine can potentiate toxic effects induced by the glutamatergic agonist ibotenate in the developing mouse brain (Laudenbach et al., 2002), indicating that, in some circumstances, $\alpha 7$ -nAChRs can have pro-apoptotic effects. In line with this evidence, the activation of $\alpha 7$ -nAChRs by nicotine induces apoptotic cell death of rat hippocampal progenitor cells. Moreover, $\alpha 7$ -nAChRs do not induce apoptosis in mature hippocampal neurons, because these neurons upregulate expression of Ca^{2+} buffers such as calbindin, and therefore, are able to counteract the large increases in $[\text{Ca}^{2+}]_i$ induced by $\alpha 7$ -nAChR activation (Berger et al., 1998a).

The above results indicate that large increases in $[\text{Ca}^{2+}]_i$ through $\alpha 7$ -nAChRs can be toxic to developing neurons. In accordance with this, a naturally occurring mutation in $\alpha 7$ -nAChR induces apoptosis in *C. elegans* due to a large Ca^{2+} influx through the slowly

desensitizing channels (Treinin and Chalfie, 1995). Furthermore, mice carrying a similar L250T mutation in their $\alpha 7$ -nAChRs, which also reduces a rate of receptor desensitization, exhibit extensive apoptotic cell death throughout the somatosensory cortex and die within 24 hours of birth (Orr-Urtreger et al., 2000). Recent evidence suggests that the $\alpha 7$ -nAChRs facilitate cell death of neurons during the period of naturally occurring cell death. For example, chicken embryos treated with sub-paralytic doses of α btx during the period of developmental cell death exhibit a small but significant increase in motoneuron survival (Hory-Lee and Frank, 1995). Similarly, chronic treatment of chicken embryos with the $\alpha 7$ -nAChR specific antagonists, α btx and MLA, rescues ciliary ganglion neurons from naturally occurring cell death (Meriney et al., 1987; Bunker and Nishi, 2002). However, the mechanism by which the $\alpha 7$ -nAChRs could induce cell death of neurons during development is unknown.

Taken together, the evidence indicates that, besides their “traditional” roles in mediating fast excitatory synaptic transmission in the autonomic ganglia, $\alpha 7$ -nAChRs mediate diverse “non-traditional” effects in the developing nervous system, ranging from the regulation of transcription to modification of neuronal circuitry and apoptosis.

Understanding these non-traditional roles will help to shed light on many different neurodevelopmental, behavioral and neurodegenerative diseases.

The Avian Ciliary Ganglion As a Model System

One of the most instructive systems for studying the function of nAChRs during development is the avian ciliary ganglion. It contains some of the highest known levels of $\alpha 7$ -nAChRs per neuron and nAChRs are essential for excitatory chemical transmission through the ganglion (Chiappinelli and Giacobini, 1978; Berg and Conroy, 2002). The ciliary ganglion is part of the parasympathetic nervous system and is derived from the mesencephalic neural crest (Hammond and Yntema, 1958; Narayanan and Narayanan, 1978a). Ciliary ganglion neuron precursors migrate from the cranial neural crest at St. 10-11 (embryonic day; E1.5) of chicken embryo development, and by St. 24 (E4) most of these neurons have reached the position of the ganglion. Ciliary ganglion neurons are born by St. 28 (E 5.5; D'Amico-Martel, 1982; Hamburger and Hamilton, 1992; Rohrer and Thoenen, 1987; Sechrist et al., 1998).

There are two types of neurons in the ciliary ganglion, ciliary and choroid, that can be distinguished morphologically and chemically. Ciliary neurons are large, myelinated neurons that innervate striated muscle in the iris and ciliary body via nAChRs, while choroid neurons are smaller, unmyelinated neurons that innervate smooth muscle of the choroid layer in the eye via muscarinic AChRs (Figure 4; Marwitt et al., 1971; Meriney and Pilar, 1987; Pilar et al., 1987). Choroid neurons can be distinguished from ciliary neurons by the presence of the neuropeptide somatostatin (Epstein et al., 1988), which acts as a co-transmitter in these neurons, inhibiting the release of ACh from the choroid nerve terminals (Gray et al., 1989; Pilar et al., 1996). Somatostatin expression in

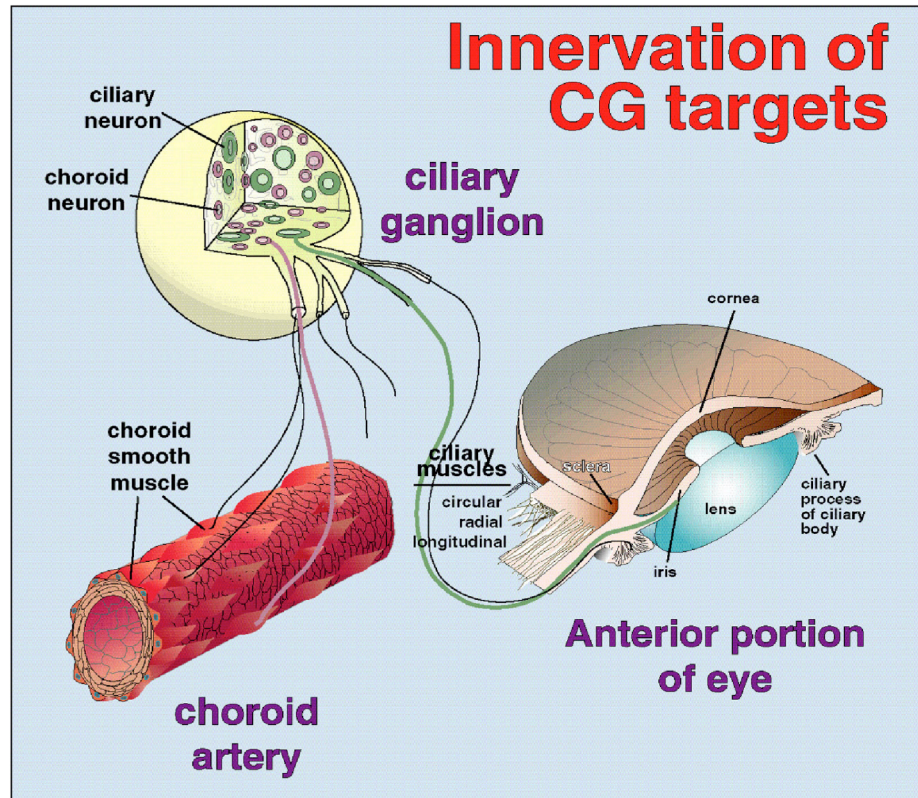

Figure 4. Location of targets in the avian ciliary ganglion.

The ciliary ganglion is a parasympathetic ganglion located in the close vicinity of the eye, next to the optic nerve. The ganglion contains two types of neurons, ciliary and choroid, innervating distinct targets in the eye. Ciliary neurons innervate striated muscle of the iris and the ciliary body via nAChRs and control lens accommodation and pupillary light reflex. Choroid neurons innervate smooth muscle of the choroidal coat via muscarinic AChRs and control the blood flow to the eye. Courtesy of Tom Finn and Rae Nishi.

choroid neurons coincides with the period of synaptogenesis with the peripheral targets, suggesting that targets differentially regulate somatostatin expression in choroid and ciliary neurons (Coulombe and Nishi, 1991). In fact, the expression of somatostatin is induced in choroid neurons by the activin molecule, a member of the TGF β superfamily, which is secreted from the targets of choroid neurons (Coulombe et al., 1993). Although activin is also secreted from the iris, the induction of somatostatin in ciliary neurons is prevented by expression of an endogenous inhibitor of activin, follistatin, in targets of the ciliary neurons (Darland et al., 1995; Darland and Nishi, 1998). Therefore, neuron-target interactions also determine the neurotransmitter phenotype in the ciliary ganglion.

Nicotinic Acetylcholine Receptors in the Ciliary Ganglion

Both types of neurons in the ciliary ganglion are cholinergic and nAChRs are essential for transmission through the ganglion. Two types of nAChRs are found on ciliary and choroid neurons, heteromeric $\alpha 3^*$ -nAChRs composed of $\alpha 3$, $\beta 4$, $\alpha 5$ and sometimes $\beta 2$ subunits, and homomeric nAChRs composed of $\alpha 7$ subunits (Conroy et al., 1992; Vernallis et al., 1993; Conroy and Berg, 1998). Heteromeric $\alpha 3^*$ -nAChRs are found in the PSDs on ciliary ganglion neurons but $\alpha 7$ -nAChRs are excluded from the postsynaptic densities and are located in perisynaptic sites (Jacob and Berg, 1983; Jacob et al., 1986; Horch and Sargent, 1995). Moreover, $\alpha 7$ -nAChRs on ciliary neurons form clusters concentrated on the somatic spines (Figure 5; Shoop et al., 1999b; Shoop et al., 2002). Although located extrasynaptically, $\alpha 7$ -nAChRs are necessary for reliable transmission

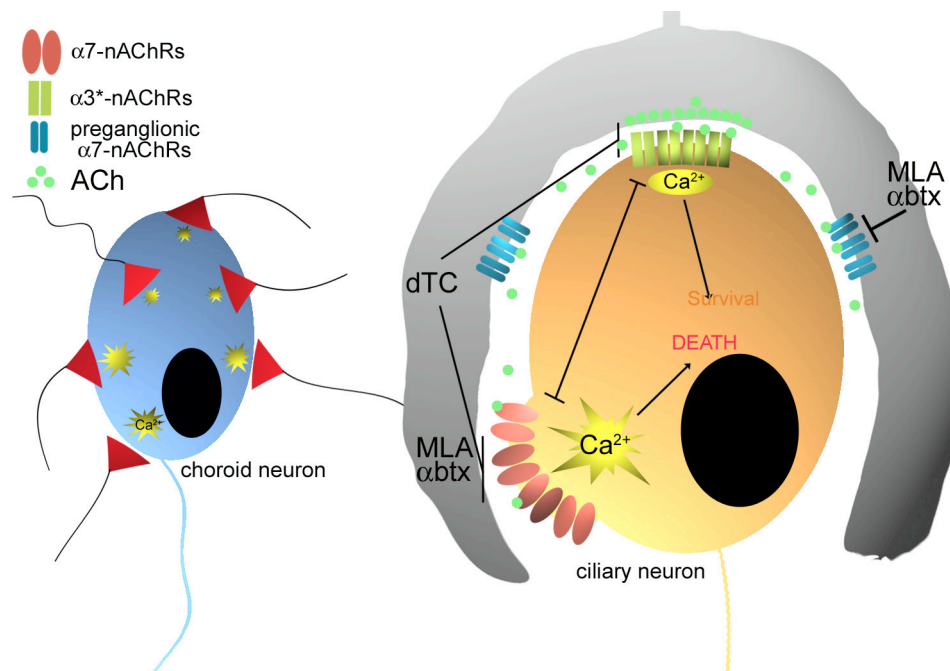

Figure 5. Nicotinic acetylcholine receptors in the ciliary ganglion.

Ciliary and choroid neurons express heteromeric α3*-nAChRs (blocked by curare) and homomeric nAChRs containing α7 subunits (blocked by αbtx or MLA). In mature ciliary neurons α3*-nAChRs are found in the PSDs while the α7-nAChRs are located extrasynaptically, clustered on the somatic spines. Although not located directly in the PSDs, extrasynaptic α7-nAChRs are still activated by ACh released from the large presynaptic calyx, engulfing the ciliary neurons. The location of α7-nAChRs on choroid neurons is less well known, and unlike ciliary neurons, choroid neurons are multiply innervated. Presynaptic α7-nAChRs modulate the release of ACh from the preganglionic neurons.

through the ganglion at early embryonic ages and contribute to more than 90% of the whole cell current in ciliary neurons (Zhang et al., 1996; Chang and Berg, 1999).

The expression of nAChRs in the ciliary ganglion is developmentally regulated. $\alpha 7$ -AChRs are present on ciliary ganglion neurons as early as E5 and their expression levels increase nine-fold between E5 and E15 (Corriveau and Berg, 1993; Brumwell et al., 2002). Similar developmental increases are seen in the expression of $\alpha 3^*$ -nAChRs between E5 and E15 but expression of $\alpha 7$ -nAChR mRNA levels are at least two-fold higher than $\alpha 3^*$ -nAChR transcripts at every developmental stage examined (Brumwell et al., 2002). These increases occur despite a 50% decrease in neuronal number as a result of naturally occurring cell death (Landmesser and Pilar, 1974a). Furthermore, the expression of nAChRs during development of the ciliary ganglion depends on targets, synaptic inputs and activity, because removal of the presynaptic input and/or the target tissue reduces expression levels of $\alpha 7$ and $\alpha 3^*$ -nAChRs. However, two types of nAChRs are regulated differently by activity. Visual deprivation downregulates $\alpha 7$ -nAChRs levels but not $\alpha 3^*$ -nAChRs levels (Brumwell et al., 2002), suggesting that $\alpha 7$ -nAChRs may also serve as the activity sensor in the ciliary ganglion.

The large increase in nAChR levels during development does not match the increase in current density through these receptors, suggesting that ciliary ganglion neurons contain a large fraction of “silent” (non-functional) receptors (Margiotta and Gurantz, 1989).

Binding assays using a mAb 35 antibody that recognizes $\alpha 1$ gene product of muscle

nAChRs and the $\alpha 5$ gene product of chicken neuronal nAChRs shows a 12-fold increase in $\alpha 3^*$ -nAChRs between E8 and E15, while the whole cell response attributed to $\alpha 3^*$ -nAChRs increases only 5-fold during the same time period (Blumenthal et al., 1999). This supports the argument that 60% of $\alpha 3^*$ -nAChRs that appear later in development on the ciliary ganglion neurons are functionally silent. Similarly, both ciliary and choroid neurons contain a large number of silent $\alpha 7$ -nAChRs. In fact, functional $\alpha 7$ -nAChRs receptors on choroid neurons represent only 8-24% of the total $\alpha 7$ -nAChRs, while the number of functional $\alpha 7$ -nAChRs on ciliary neurons represents 3-8% of the total $\alpha 7$ -nAChRs (McNerney et al., 2000a). Furthermore, nicotinic response densities attributable to $\alpha 7$ -nAChRs are 3-fold larger on choroid neurons than on ciliary neurons, while those attributable to $\alpha 3^*$ -nAChRs are similar between the two neuronal populations (McNerney et al., 2000a). The significance of these silent receptors is unknown, but this could reflect a regulatory mechanism that comes into play later in development to control the number of receptors available for activation.

All ciliary ganglion neurons receive functional nicotinic innervation by E7 and by E8 the transmission through the ganglion is 100% (Landmesser and Pilar, 1972). Preganglionic neurons located in the accessory oculomotor nucleus (AON) in the midbrain also contain $\alpha 7$ -nAChRs on their terminals, which are activated by ACh released from the same terminals (Coggan et al., 1997; Rogers and Sargent, 2003). The activation of presynaptic $\alpha 7$ -nAChRs leads to Ca^{2+} elevation within the presynaptic terminal and enhanced release of ACh in a positive feedback manner. Therefore the release of ACh and the activation

of presynaptic $\alpha 7$ -nAChRs can influence transmission through the ciliary ganglion based on the firing rate of preganglionic neurons.

Developmental Cell Death in the Ciliary Ganglion

The developmental cell death of ciliary ganglion neurons has been well documented (Landmesser and Pilar, 1974a). Between St. 34 and 40 (E8 and E14), 50% of ciliary ganglion neurons are eliminated due to programmed cell death. This cell loss coincides with the period of peripheral synaptogenesis, which occurs between E9 and E14, and has been shown to be target-dependent since removal of the eye before onset of cell loss exacerbates cell death of ciliary ganglion neurons (Landmesser and Pilar, 1974a). In fact, ciliary ganglion neurons are dependent on the ciliary neurotrophic factor (CNTF), a target-derived factor, for survival *in vivo* and *in vitro*. The overexpression of chCNTF reduces the cell death of ciliary ganglion neurons *in vivo* (Finn and Nishi, 1996; Finn et al., 1998). The treatment of ciliary ganglion neurons in culture with glial cell line-derived neurotrophic factor (GDNF) has also been demonstrated to support survival (Hashino et al., 1999; Hashino et al., 2001). Although there is a wave of apoptosis at E8 after which 50% of neurons are eliminated, a significant number of neurons in the ciliary ganglion are dying at E6, well before the neurons make contact with peripheral targets (Lee et al., 2001). These results indicate that targets control cell death of ciliary ganglion neurons at least in part by limiting the availability of trophic support but other mechanisms are also involved (Figure 6).

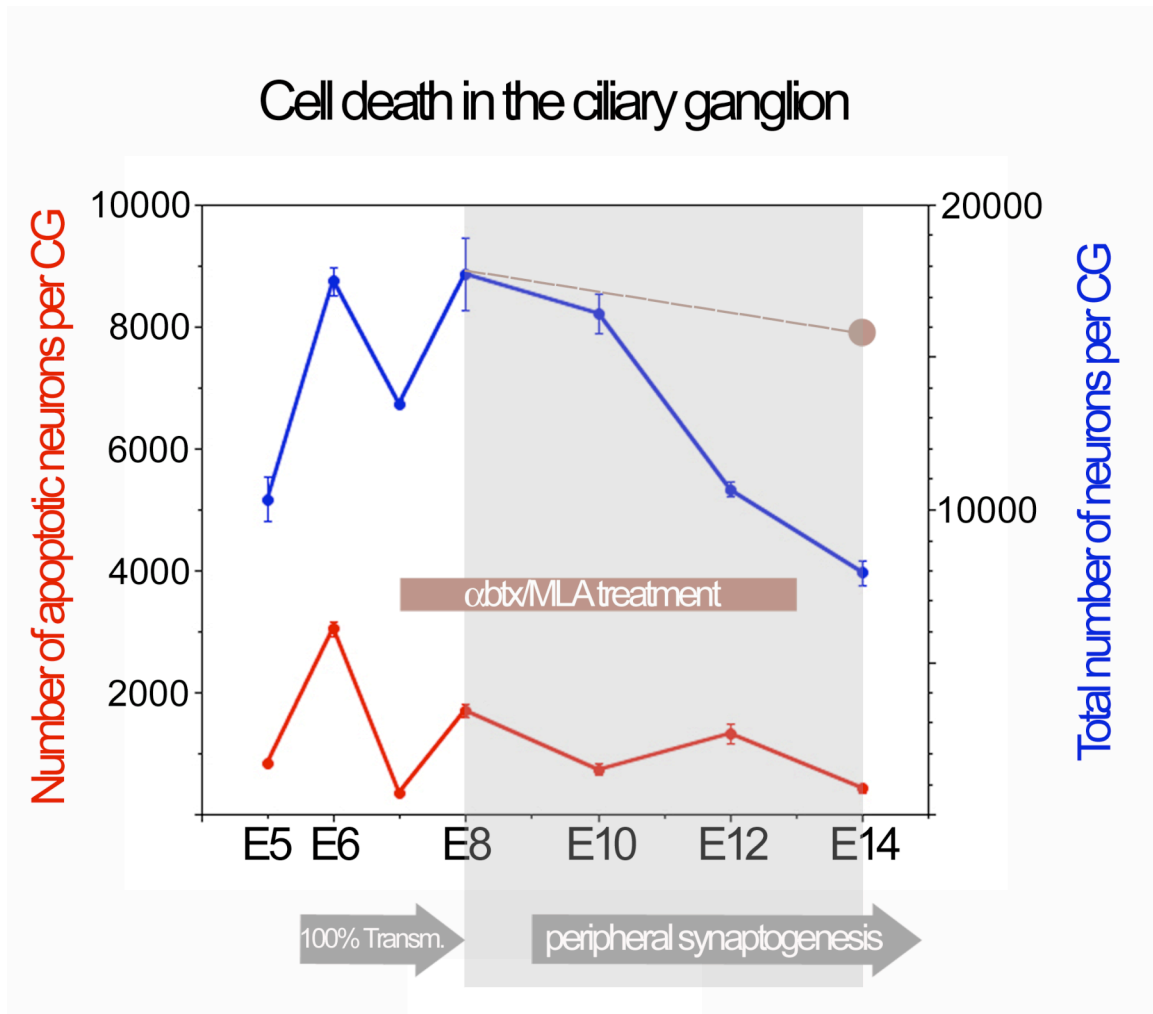

Figure 6. Cell death in the ciliary ganglion.

Between E8 and E14, 50% of neurons are lost due to programmed cell death (blue trace). This cell loss occurs at the time when neurons are making contacts with their targets. Nearly all neurons are prevented from dying when the embryos are treated with α btx or MLA between E7 and E13, implicating $\alpha 7$ -nAChR in facilitating cell death (Bunker and Nishi, 2002). The neurons in the ganglion are dying at much earlier stage (E6, red trace), at the time of ganglion innervation and well before synaptogenesis with targets. These neurons are replaced by E8 before 50% of them are eliminated (Lee et al., 2001).

In addition to the target-derived trophic factors, activity also influences the survival of the ciliary ganglion neurons. The removal of the preganglionic input to the ciliary ganglion exacerbates cell death (Furber et al., 1987) and treatment of embryos with pan-nicotinic cholinergic antagonists such as chlorisondamine, pempidine, or d-tubocurare, also reduce the survival of ciliary ganglion neurons (Wright, 1981b; Meriney et al., 1987b; Maderdrut et al., 1988), presumably by blocking the ganglionic transmission. In contrast, treatment of chicken embryos with $\alpha 7$ -nAChRs-specific antagonists such as α btx and methyllycaconitine (MLA), between E7 and E14, prevents cell death of almost all ciliary ganglion neurons (Bunker and Nishi, 2002). Therefore, control of cell death in the ciliary ganglion by afferent input is complex and activation of different classes of nAChRs can have different outcomes for the survival of ciliary ganglion neurons. The data summarized above indicate that multiple mechanisms work together to control neuronal cell death in the ciliary ganglion and interplay between retrograde and anterograde factors determines the final number of neurons in the ciliary ganglion.

Aims of This Dissertation

Even though developmental cell death in the vertebrate nervous system has been extensively described, the means by which cell death is induced are not well understood. The neurotrophic hypothesis states that neurons that do not adequately compete for the limited amount target-derived factors die and neurons that compete well survive. However, it is unclear how targets limit access to target-derived factors, because they

secrete them in a constitutive manner. Since almost all neurons can be prevented from dying by other manipulations, such as treatment with cholinergic antagonists, additional mechanisms must be involved in the regulation of neuronal survival during development. The studies in the ciliary ganglion suggest that $\alpha 7$ -nAChRs induce the cell death of ciliary ganglion neurons (Bunker and Nishi, 2002). However, the antagonists in these studies were applied directly to the chorioallantoic membrane of chicken embryos, causing the systemic inhibition of nAChRs and, therefore, the site at which they work is not clear. If the activation of $\alpha 7$ -nAChRs induces cell death, the mechanism by which this happens is not known.

Based on these preliminary results, I proposed to test the hypothesis that **the activation of $\alpha 7$ -nAChRs *in vivo* facilitates the cell death of ciliary ganglion neurons by increasing the $[Ca^{2+}]_i$ over the threshold for cell death.** I proposed to test this hypothesis by performing experiments outlined below:

Specific Aim 1: Tested the hypothesis that ciliary ganglion neurons express heterogeneous levels of $\alpha 7$ -nAChRs on their surface. Only 50% of neurons are eliminated between E8 and E14. Therefore, if $\alpha 7$ -nAChRs facilitate cell death, they do so only in a subset of ciliary ganglion neurons. In this aim I tested whether before the onset of cell loss in the ciliary ganglion some neurons express higher levels of surface $\alpha 7$ -nAChRs and thus are more likely to die from Ca^{2+} overload.

Specific Aim 2: Tested the hypothesis that cell-autonomous inhibition of $\alpha 7$ -nAChRs on ciliary ganglion neurons prevents neuronal cell death in the ganglion.

Although treatment of embryos with $\alpha 7$ -nAChR antagonists prevents cell death of ciliary ganglion neurons, the site of action of these antagonists is not clear. Therefore I tested whether the inhibition of $\alpha 7$ -nAChRs directly on ciliary ganglion neurons prevents neuronal cell death.

Specific Aim 3: Tested the hypothesis that endogenous modulators of $\alpha 7$ -nAChR function prevent $\alpha 7$ -nAChR-mediated cell death signaling later in development. If $\alpha 7$ -nAChRs facilitate cell death of the ciliary ganglion neurons, how are these receptors prevented from inducing cell death after the final number of neurons in the ciliary ganglion has been determined? I tested whether endogenous prototoxins that modulate nAChR function are present in the ciliary ganglion during the period of cell death and prevent the large increases in $[Ca^{2+}]_i$ via $\alpha 7$ -nAChRs, thus, preventing these receptors from activating the cell death machinery after the neuronal numbers in the ciliary ganglion have been established.

LITERATURE CITED

Ameisen JC (1996) The origin of programmed cell death. *Science* 272:1278-1279.

Anand R, Conroy WG, Schoepfer R, Whiting P, Lindstrom J (1991) Neuronal nicotinic acetylcholine receptors expressed in *Xenopus* oocytes have a pentameric quaternary structure. *J Biol Chem* 266:11192-11198.

Bansal A, Singer JH, Hwang BJ, Xu W, Beaudet A, Feller MB (2000) Mice lacking specific nicotinic acetylcholine receptor subunits exhibit dramatically altered spontaneous activity patterns and reveal a limited role for retinal waves in forming ON and OFF circuits in the inner retina. *J Neurosci* 20:7672-7681.

Barde YA, Edgar D, Thoenen H (1982) Purification of a new neurotrophic factor from mammalian brain. *Embo J* 1:549-553.

Berg DK, Conroy WG (2002) Nicotinic alpha 7 receptors: synaptic options and downstream signaling in neurons. *J Neurobiol* 53:512-523.

Berg DK, Conroy WG, Liu Z, Zago WM (2006) Nicotinic signal transduction machinery. *J Mol Neurosci* 30:149-152.

Berger F, Gage FH, Vijayaraghavan S (1998) Nicotinic receptor-induced apoptotic cell death of hippocampal progenitor cells. *J Neurosci* 18:6871-6881.

Berkemeier LR, Winslow JW, Kaplan DR, Nikolics K, Goeddel DV, Rosenthal A (1991) Neurotrophin-5: a novel neurotrophic factor that activates trk and trkB. *Neuron* 7:857-866.

Berridge MJ, Bootman MD, Roderick HL (2003) Calcium signalling: dynamics, homeostasis and remodelling. *Nat Rev Mol Cell Biol* 4:517-529.

Bertrand D, Galzi JL, Devillers-Thiery A, Bertrand S, Changeux JP (1993) Mutations at two distinct sites within the channel domain M2 alter calcium permeability of neuronal alpha 7 nicotinic receptor. *Proc Natl Acad Sci U S A* 90:6971-6975.

Bina KG, Guzman P, Broide RS, Leslie FM, Smith MA, O'Dowd DK (1995) Localization of alpha 7 nicotinic receptor subunit mRNA and alpha-bungarotoxin binding sites in developing mouse somatosensory thalamocortical system. *J Comp Neurol* 363:321-332.

Blumenthal EM, Shoop RD, Berg DK (1999) Developmental changes in the nicotinic responses of ciliary ganglion neurons. *J Neurophysiol* 81:111-120.

Boydston WR, Sohal GS (1979) Grafting of additional periphery reduces embryonic loss of neurons. *Brain Res* 178:403-410.

Broide RS, Leslie FM (1999) The alpha7 nicotinic acetylcholine receptor in neuronal plasticity. *Mol Neurobiol* 20:1-16.

Broide RS, O'Connor LT, Smith MA, Smith JA, Leslie FM (1995) Developmental expression of alpha 7 neuronal nicotinic receptor messenger RNA in rat sensory cortex and thalamus. *Neuroscience* 67:83-94.

Brumwell CL, Johnson JL, Jacob MH (2002) Extrasynaptic alpha 7-nicotinic acetylcholine receptor expression in developing neurons is regulated by inputs, targets, and activity. *J Neurosci* 22:8101-8109.

Bunker GL, Nishi R (2002) Developmental cell death in vivo: rescue of neurons independently of changes at target tissues. *J Comp Neurol* 452:80-92.

Buss RR, Sun W, Oppenheim RW (2006) Adaptive roles of programmed cell death during nervous system development. *Annu Rev Neurosci* 29:1-35.

Carlson NG, Bacchi A, Rogers SW, Gahring LC (1998) Nicotine blocks TNF-alpha-mediated neuroprotection to NMDA by an alpha-bungarotoxin-sensitive pathway. *J Neurobiol* 35:29-36.

Castro NG, Albuquerque EX (1995) alpha-Bungarotoxin-sensitive hippocampal nicotinic receptor channel has a high calcium permeability. *Biophys J* 68:516-524.

Catsicas M, Pequignot Y, Clarke PG (1992) Rapid onset of neuronal death induced by blockade of either axoplasmic transport or action potentials in afferent fibers during brain development. *J Neurosci* 12:4642-4650.

Catsicas S, Thanos S, Clarke PG (1987) Major role for neuronal death during brain development: refinement of topographical connections. *Proc Natl Acad Sci U S A* 84:8165-8168.

Chang KT, Berg DK (1999) Nicotinic acetylcholine receptors containing alpha7 subunits are required for reliable synaptic transmission in situ. *J Neurosci* 19:3701-3710.

Chang KT, Berg DK (2001) Voltage-gated channels block nicotinic regulation of CREB phosphorylation and gene expression in neurons. *Neuron* 32:855-865.

Charpantier E, Barneoud P, Moser P, Besnard F, Sgard F (1998) Nicotinic acetylcholine subunit mRNA expression in dopaminergic neurons of the rat substantia nigra and ventral tegmental area. *Neuroreport* 9:3097-3101.

Chiappinelli VA, Giacobini E (1978) Time course of appearance of alpha-bungarotoxin binding sites during development of chick ciliary ganglion and iris. *Neurochem Res* 3:465-478.

Choi DW (1994) Glutamate receptors and the induction of excitotoxic neuronal death. *Prog Brain Res* 100:47-51.

Clarke PG, Cowan WM (1975) Ectopic neurons and aberrant connections during neural development. *Proc Natl Acad Sci U S A* 72:4455-4458.

Clarke PG, Cowan WM (1976) The development of the isthmo-optic tract in the chick, with special reference to the occurrence and correction of developmental errors in the location and connections of isthmo-optic neurons. *J Comp Neurol* 167:143-164.

Clarke PG, Posada A, Primi MP, Castagne V (1998) Neuronal death in the central nervous system during development. *Biomed Pharmacother* 52:356-362.

Coggan JS, Paysan J, Conroy WG, Berg DK (1997) Direct recording of nicotinic responses in presynaptic nerve terminals. *J Neurosci* 17:5798-5806.

Cohen-Cory S, Dreyfus CF, Black IB (1991) NGF and excitatory neurotransmitters regulate survival and morphogenesis of cultured cerebellar Purkinje cells. *J Neurosci* 11:462-471.

Collins F, Lile JD (1989) The role of dihydropyridine-sensitive voltage-gated calcium channels in potassium-mediated neuronal survival. *Brain Res* 502:99-108.

Collins F, Schmidt MF, Guthrie PB, Kater SB (1991) Sustained increase in intracellular calcium promotes neuronal survival. *J Neurosci* 11:2582-2587.

Conroy WG, Berg DK (1998) Nicotinic receptor subtypes in the developing chick brain: appearance of a species containing the alpha4, beta2, and alpha5 gene products. *Mol Pharmacol* 53:392-401.

Conroy WG, Vernallis AB, Berg DK (1992) The alpha 5 gene product assembles with multiple acetylcholine receptor subunits to form distinctive receptor subtypes in brain. *Neuron* 9:679-691.

Conroy WG, Liu Z, Nai Q, Coggan JS, Berg DK (2003) PDZ-containing proteins provide a functional postsynaptic scaffold for nicotinic receptors in neurons. *Neuron* 38:759-771.

Coronas V, Durand M, Chabot JG, Jourdan F, Quirion R (2000) Acetylcholine induces neuritic outgrowth in rat primary olfactory bulb cultures. *Neuroscience* 98:213-219.

Corriveau RA, Berg DK (1993) Coexpression of multiple acetylcholine receptor genes in neurons: quantification of transcripts during development. *J Neurosci* 13:2662-2671.

Coulombe JN, Nishi R (1991) Stimulation of somatostatin expression in developing ciliary ganglion neurons by cells of the choroid layer. *J Neurosci* 11:553-562.

Coulombe JN, Schwall R, Parent AS, Eckenstein FP, Nishi R (1993) Induction of somatostatin immunoreactivity in cultured ciliary ganglion neurons by activin in choroid cell-conditioned medium. *Neuron* 10:899-906.

Couturier S, Bertrand D, Matter JM, Hernandez MC, Bertrand S, Millar N, Valera S, Barkas T, Ballivet M (1990) A neuronal nicotinic acetylcholine receptor subunit (alpha 7) is developmentally regulated and forms a homo-oligomeric channel blocked by alpha-BTX. *Neuron* 5:847-856.

Cowan WM, Fawcett JW, O'Leary DD, Stanfield BB (1984) Regressive events in neurogenesis. *Science* 225:1258-1265.

Crespo D, O'Leary DD, Cowan WM (1985) Changes in the numbers of optic nerve fibers during late prenatal and postnatal development in the albino rat. *Brain Res* 351:129-134.

Crowley C, Spencer SD, Nishimura MC, Chen KS, Pitts-Meek S, Armanini MP, Ling LH, McMahon SB, Shelton DL, Levinson AD, et al. (1994) Mice lacking nerve growth factor display perinatal loss of sensory and sympathetic neurons yet develop basal forebrain cholinergic neurons. *Cell* 76:1001-1011.

Cuevas J, Berg DK (1998) Mammalian nicotinic receptors with alpha7 subunits that slowly desensitize and rapidly recover from alpha-bungarotoxin blockade. *J Neurosci* 18:10335-10344.

D'Amico-Martel A (1982) Temporal patterns of neurogenesis in avian cranial sensory and autonomic ganglia. *Am J Anat* 163:351-372.

Dahm LM, Landmesser LT (1988) The regulation of intramuscular nerve branching during normal development and following activity blockade. *Dev Biol* 130:621-644.

Dani JA (2001) Overview of nicotinic receptors and their roles in the central nervous system. *Biol Psychiatry* 49:166-174.

Dani JA, Bertrand D (2007) Nicotinic acetylcholine receptors and nicotinic cholinergic mechanisms of the central nervous system. *Annu Rev Pharmacol Toxicol* 47:699-729.

Dani JA, Radcliffe KA, Pidoplichko VI (2000) Variations in desensitization of nicotinic acetylcholine receptors from hippocampus and midbrain dopamine areas. *Eur J Pharmacol* 393:31-38.

Darland DC, Nishi R (1998) Activin A and follistatin influence expression of somatostatin in the ciliary ganglion in vivo. *Dev Biol* 202:293-303.

Darland DC, Link BA, Nishi R (1995) Activin A and follistatin expression in developing targets of ciliary ganglion neurons suggests a role in regulating neurotransmitter phenotype. *Neuron* 15:857-866.

Davies AM (1996) The neurotrophic hypothesis: where does it stand? *Philos Trans R Soc Lond B Biol Sci* 351:389-394.

Davis BM, Lewin GR, Mendell LM, Jones ME, Albers KM (1993) Altered expression of nerve growth factor in the skin of transgenic mice leads to changes in response to mechanical stimuli. *Neuroscience* 56:789-792.

Eichler ME, Dubinsky JM, Rich KM (1992) Relationship of intracellular calcium to dependence on nerve growth factor in dorsal root ganglion neurons in cell culture. *J Neurochem* 58:263-269.

Eisen JS, Melancon E (2001) Interactions with identified muscle cells break motoneuron equivalence in embryonic zebrafish. *Nat Neurosci* 4:1065-1070.

Ellis HM, Horvitz HR (1986) Genetic control of programmed cell death in the nematode *C. elegans*. *Cell* 44:817-829.

Epstein ML, Davis JP, Gellman LE, Lamb JR, Dahl JL (1988) Cholinergic neurons of the chicken ciliary ganglion contain somatostatin. *Neuroscience* 25:1053-1060.

Ernfors P, Lee KF, Jaenisch R (1994a) Mice lacking brain-derived neurotrophic factor develop with sensory deficits. *Nature* 368:147-150.

Ernfors P, Lee KF, Kucera J, Jaenisch R (1994b) Lack of neurotrophin-3 leads to deficiencies in the peripheral nervous system and loss of limb proprioceptive afferents. *Cell* 77:503-512.

Ernfors P, Ibanez CF, Ebendal T, Olson L, Persson H (1990) Molecular cloning and neurotrophic activities of a protein with structural similarities to nerve growth factor: developmental and topographical expression in the brain. *Proc Natl Acad Sci U S A* 87:5454-5458.

Fabian-Fine R, Skehel P, Errington ML, Davies HA, Sher E, Stewart MG, Fine A (2001) Ultrastructural distribution of the alpha7 nicotinic acetylcholine receptor subunit in rat hippocampus. *J Neurosci* 21:7993-8003.

Feller MB, Wellis DP, Stellwagen D, Werblin FS, Shatz CJ (1996) Requirement for cholinergic synaptic transmission in the propagation of spontaneous retinal waves. *Science* 272:1182-1187.

Fiedler EP, Marks MJ, Collins AC (1990) Postnatal development of two nicotinic cholinergic receptors in seven mouse brain regions. *Int J Dev Neurosci* 8:533-540.

Finn TP, Nishi R (1996) Expression of a chicken ciliary neurotrophic factor in targets of ciliary ganglion neurons during and after the cell-death phase. *J Comp Neurol* 366:559-571.

Finn TP, Kim S, Nishi R (1998) Overexpression of ciliary neurotrophic factor in vivo rescues chick ciliary ganglion neurons from cell death. *J Neurobiol* 34:283-293.

Flores CM, Rogers SW, Pabreza LA, Wolfe BB, Kellar KJ (1992) A subtype of nicotinic cholinergic receptor in rat brain is composed of alpha 4 and beta 2 subunits and is up-regulated by chronic nicotine treatment. *Mol Pharmacol* 41:31-37.

Forster I, Bertrand D (1995) Inward rectification of neuronal nicotinic acetylcholine receptors investigated by using the homomeric alpha 7 receptor. *Proc Biol Sci* 260:139-148.

Frazier CJ, Buhler AV, Weiner JL, Dunwiddie TV (1998) Synaptic potentials mediated via alpha-bungarotoxin-sensitive nicotinic acetylcholine receptors in rat hippocampal interneurons. *J Neurosci* 18:8228-8235.

Freedman R, Wetmore C, Stromberg I, Leonard S, Olson L (1993) Alpha-bungarotoxin binding to hippocampal interneurons: immunocytochemical characterization and effects on growth factor expression. *J Neurosci* 13:1965-1975.

Freeman JA (1977) Possible regulatory function of acetylcholine receptor in maintenance of retinotectal synapses. *Nature* 269:218-222.

Furber S, Oppenheim RW, Prevet D (1987) Naturally-occurring neuron death in the ciliary ganglion of the chick embryo following removal of preganglionic input: evidence for the role of afferents in ganglion cell survival. *J Neurosci* 7:1816-1832.

Galli-Resta L, Ensini M, Fusco E, Gravina A, Margheritti B (1993) Afferent spontaneous electrical activity promotes the survival of target cells in the developing retinotectal system of the rat. *J Neurosci* 13:243-250.

Gotti C, Clementi F (2004) Neuronal nicotinic receptors: from structure to pathology. *Prog Neurobiol* 74:363-396.

Gray DB, Pilar GR, Ford MJ (1989) Opiate and peptide inhibition of transmitter release in parasympathetic nerve terminals. *J Neurosci* 9:1683-1692.

Gray R, Rajan AS, Radcliffe KA, Yakehiro M, Dani JA (1996) Hippocampal synaptic transmission enhanced by low concentrations of nicotine. *Nature* 383:713-716.

Greenberg ME, Ziff EB, Greene LA (1986) Stimulation of neuronal acetylcholine receptors induces rapid gene transcription. *Science* 234:80-83.

- Grieshammer U, Lewandoski M, Prevet D, Oppenheim RW, Martin GR (1998) Muscle-specific cell ablation conditional upon Cre-mediated DNA recombination in transgenic mice leads to massive spinal and cranial motoneuron loss. *Dev Biol* 197:234-247.
- Hajnoczky G, Davies E, Madesh M (2003) Calcium signaling and apoptosis. *Biochem Biophys Res Commun* 304:445-454.
- Hamburger V (1958) Regression versus peripheral control of differentiation in motor hypoplasia. *Am J Anat* 102:365-409.
- Hamburger V, Yip JW (1984) Reduction of experimentally induced neuronal death in spinal ganglia of the chick embryo by nerve growth factor. *J Neurosci* 4:767-774.
- Hamburger V, Hamilton HL (1992) A series of normal stages in the development of the chick embryo. 1951. *Dev Dyn* 195:231-272.
- Hammond WS, Yntema CL (1958) Origin of ciliary ganglia in the chick. *J Comp Neurol* 110:367-389.
- Hanson MG, Landmesser LT (2003) Characterization of the circuits that generate spontaneous episodes of activity in the early embryonic mouse spinal cord. *J Neurosci* 23:587-600.

Hashino E, Johnson EM, Jr., Milbrandt J, Shero M, Salvi RJ, Cohan CS (1999) Multiple actions of neurturin correlate with spatiotemporal patterns of Ret expression in developing chick cranial ganglion neurons. *J Neurosci* 19:8476-8486.

Hashino E, Shero M, Junghans D, Rohrer H, Milbrandt J, Johnson EM, Jr. (2001) GDNF and neurturin are target-derived factors essential for cranial parasympathetic neuron development. *Development* 128:3773-3782.

Hollyday M, Hamburger V (1976) Reduction of the naturally occurring motor neuron loss by enlargement of the periphery. *J Comp Neurol* 170:311-320.

Horch HL, Sargent PB (1995) Perisynaptic surface distribution of multiple classes of nicotinic acetylcholine receptors on neurons in the chicken ciliary ganglion. *J Neurosci* 15:7778-7795.

Hory-Lee F, Frank E (1995) The nicotinic blocking agents d-tubocurarine and alpha-bungarotoxin save motoneurons from naturally occurring death in the absence of neuromuscular blockade. *J Neurosci* 15:6453-6460.

Jacob MH, Berg DK (1983) The ultrastructural localization of alpha-bungarotoxin binding sites in relation to synapses on chick ciliary ganglion neurons. *J Neurosci* 3:260-271.

Jacob MH, Lindstrom JM, Berg DK (1986) Surface and intracellular distribution of a putative neuronal nicotinic acetylcholine receptor. *J Cell Biol* 103:205-214.

Johnson EM, Jr., Koike T, Franklin J (1992) A "calcium set-point hypothesis" of neuronal dependence on neurotrophic factor. *Exp Neurol* 115:163-166.

Johnson EM, Jr., Gorin PD, Brandeis LD, Pearson J (1980) Dorsal root ganglion neurons are destroyed by exposure in utero to maternal antibody to nerve growth factor. *Science* 210:916-918.

Jones KR, Reichardt LF (1990) Molecular cloning of a human gene that is a member of the nerve growth factor family. *Proc Natl Acad Sci U S A* 87:8060-8064.

Jones KR, Farinas I, Backus C, Reichardt LF (1994) Targeted disruption of the BDNF gene perturbs brain and sensory neuron development but not motor neuron development. *Cell* 76:989-999.

Karlin A (2002) Emerging structure of the nicotinic acetylcholine receptors. *Nat Rev Neurosci* 3:102-114.

Kawai H, Zago W, Berg DK (2002) Nicotinic alpha 7 receptor clusters on hippocampal GABAergic neurons: regulation by synaptic activity and neurotrophins. *J Neurosci* 22:7903-7912.

Khiroug SS, Harkness PC, Lamb PW, Sudweeks SN, Khiroug L, Millar NS, Yakel JL (2002) Rat nicotinic ACh receptor alpha7 and beta2 subunits co-assemble to form functional heteromeric nicotinic receptor channels. *J Physiol* 540:425-434.

King WM (1990) Nicotinic depolarization of optic nerve terminals augments synaptic transmission. *Brain Res* 527:150-154.

Klein R, Silos-Santiago I, Smeyne RJ, Lira SA, Brambilla R, Bryant S, Zhang L, Snider WD, Barbacid M (1994) Disruption of the neurotrophin-3 receptor gene *trkC* eliminates Ia muscle afferents and results in abnormal movements. *Nature* 368:249-251.

Koike T, Tanaka S (1991) Evidence that nerve growth factor dependence of sympathetic neurons for survival in vitro may be determined by levels of cytoplasmic free Ca²⁺. *Proc Natl Acad Sci U S A* 88:3892-3896.

Koike T, Martin DP, Johnson EM, Jr. (1989) Role of Ca²⁺ channels in the ability of membrane depolarization to prevent neuronal death induced by trophic-factor deprivation: evidence that levels of internal Ca²⁺ determine nerve growth factor dependence of sympathetic ganglion cells. *Proc Natl Acad Sci U S A* 86:6421-6425.

Kuida K, Zheng TS, Na S, Kuan C, Yang D, Karasuyama H, Rakic P, Flavell RA (1996) Decreased apoptosis in the brain and premature lethality in CPP32-deficient mice. *Nature* 384:368-372.

Lachica EA, Kato BM, Lippe WR, Rubel EW (1998) Glutamatergic and GABAergic agonists increase $[Ca^{2+}]_i$ in avian cochlear nucleus neurons. *J Neurobiol* 37:321-337.

Lamb AH (1980) Motoneurone counts in *Xenopus* frogs reared with one bilaterally-innervated hindlimb. *Nature* 284:347-350.

Lampe PA, Cornbrooks EB, Juhasz A, Johnson EM, Jr., Franklin JL (1995) Suppression of programmed neuronal death by a thapsigargin-induced Ca^{2+} influx. *J Neurobiol* 26:205-212.

Land PW, Lund RD (1979) Development of the rat's uncrossed retinotectal pathway and its relation to plasticity studies. *Science* 205:698-700.

Landmesser L (1992) The relationship of intramuscular nerve branching and synaptogenesis to motoneuron survival. *J Neurobiol* 23:1131-1139.

Landmesser L, Pilar G (1972) The onset and development of transmission in the chick ciliary ganglion. *J Physiol* 222:691-713.

Landmesser L, Pilar G (1974a) Synaptic transmission and cell death during normal ganglionic development. *J Physiol* 241:737-749.

Landmesser L, Pilar G (1974b) Synapse formation during embryogenesis in ganglion cells lacking the periphery. *J Physiol* 241:715-736.

Landmesser LT, Szente M (1986) Activation patterns of embryonic chick hind-limb muscles following blockade of activity and motoneurone cell death. *J Physiol* 380:157-174.

Lapchak PA, Araujo DM, Quirion R, Collier B (1989) Presynaptic cholinergic mechanisms in the rat cerebellum: evidence for nicotinic, but not muscarinic autoreceptors. *J Neurochem* 53:1843-1851.

Laudenbach V, Medja F, Zoli M, Rossi FM, Evrard P, Changeux JP, Gressens P (2002) Selective activation of central subtypes of the nicotinic acetylcholine receptor has opposite effects on neonatal excitotoxic brain injuries. *FASEB J* 16:423-425.

Lee VM, Smiley GG, Nishi R (2001) Cell death and neuronal replacement during formation of the avian ciliary ganglion. *Dev Biol* 233:437-448.

Lena C, Changeux JP (1998) Allosteric nicotinic receptors, human pathologies. *J Physiol Paris* 92:63-74.

Lena C, Changeux JP, Mulle C (1993) Evidence for "preterminal" nicotinic receptors on GABAergic axons in the rat interpeduncular nucleus. *J Neurosci* 13:2680-2688.

Leung DW, Parent AS, Cachianes G, Esch F, Coulombe JN, Nikolics K, Eckenstein FP, Nishi R (1992) Cloning, expression during development, and evidence for release of a trophic factor for ciliary ganglion neurons. *Neuron* 8:1045-1053.

Levi-Montalcini R, Angeletti PU (1968) Nerve growth factor. *Physiol Rev* 48:534-569.

Levy RB, Aoki C (2002) Alpha7 nicotinic acetylcholine receptors occur at postsynaptic densities of AMPA receptor-positive and -negative excitatory synapses in rat sensory cortex. *J Neurosci* 22:5001-5015.

Linden R (1994) The survival of developing neurons: a review of afferent control. *Neuroscience* 58:671-682.

Lipton SA (1986) Blockade of electrical activity promotes the death of mammalian retinal ganglion cells in culture. *Proc Natl Acad Sci U S A* 83:9774-9778.

Listerud M, Brussaard AB, Devay P, Colman DR, Role LW (1991) Functional contribution of neuronal AChR subunits revealed by antisense oligonucleotides. *Science* 254:1518-1521.

Liu Z, Neff RA, Berg DK (2006) Sequential interplay of nicotinic and GABAergic signaling guides neuronal development. *Science* 314:1610-1613.

Maderdrut JL, Oppenheim RW, Prevet D (1988) Enhancement of naturally occurring cell death in the sympathetic and parasympathetic ganglia of the chicken embryo following blockade of ganglionic transmission. *Brain Res* 444:189-194.

Margiotta JF, Gurantz D (1989) Changes in the number, function, and regulation of nicotinic acetylcholine receptors during neuronal development. *Dev Biol* 135:326-339.

Marwitt R, Pilar G, Weakly JN (1971) Characterization of two ganglion cell populations in avian ciliary ganglia. *Brain Res* 25:317-334.

McGehee DS, Role LW (1995) Physiological diversity of nicotinic acetylcholine receptors expressed by vertebrate neurons. *Annu Rev Physiol* 57:521-546.

McGehee DS, Heath MJ, Gelber S, Devay P, Role LW (1995) Nicotine enhancement of fast excitatory synaptic transmission in CNS by presynaptic receptors. *Science* 269:1692-1696.

McLoon SC, Lund RD (1982) Transient retinofugal pathways in the developing chick. *Exp Brain Res* 45:277-284.

McNerney ME, Pardi D, Pugh PC, Nai Q, Margiotta JF (2000) Expression and channel properties of alpha-bungarotoxin-sensitive acetylcholine receptors on chick ciliary and choroid neurons. *J Neurophysiol* 84:1314-1329.

Mennerick S, Zorumski CF (2000) Neural activity and survival in the developing nervous system. *Mol Neurobiol* 22:41-54.

Meriney SD, Pilar G (1987) Cholinergic innervation of the smooth muscle cells in the choroid coat of the chick eye and its development. *J Neurosci* 7:3827-3839.

Meriney SD, Pilar G, Ogawa M, Nunez R (1987) Differential neuronal survival in the avian ciliary ganglion after chronic acetylcholine receptor blockade. *J Neurosci* 7:3840-3849.

Narayanan CH, Narayanan Y (1978a) On the origin of the ciliary ganglion in birds studied by the method of interspecific transplantation of embryonic brain regions between quail and chick. *J Embryol Exp Morphol* 47:137-148.

Narayanan CH, Narayanan Y (1978b) Neuronal adjustments in developing nuclear centers of the chick embryo following transplantation of an additional optic primordium. *J Embryol Exp Morphol* 44:53-70.

Nishi R, Berg DK (1977) Dissociated ciliary ganglion neurons in vitro: survival and synapse formation. *Proc Natl Acad Sci U S A* 74:5171-5175.

Nishi R, Berg DK (1979) Survival and development of ciliary ganglion neurones grown alone in cell culture. *Nature* 277:232-234.

O'Leary DD, Cowan WM (1982) Further studies on the development of the isthmo-optic nucleus with special reference to the occurrence and fate of ectopic and ipsilaterally projecting neurons. *J Comp Neurol* 212:399-416.

O'Leary DD, Cowan WM (1984) Survival of isthmo-optic neurons after early removal of one eye. *Brain Res* 314:293-310.

O'Leary DD, Fawcett JW, Cowan WM (1986) Topographic targeting errors in the retinocollicular projection and their elimination by selective ganglion cell death. *J Neurosci* 6:3692-3705.

O'Leary DM, Gerfen CR, Cowan WM (1983) The development and restriction of the ipsilateral retinofugal projection in the chick. *Brain Res* 312:93-109.

Oppenheim RW (1989) The neurotrophic theory and naturally occurring motoneuron death. *Trends Neurosci* 12:252-255.

Oppenheim RW (1991) Cell death during development of the nervous system. *Annu Rev Neurosci* 14:453-501.

Oppenheim RW, Chu-Wang IW, Maderdrut JL (1978) Cell death of motoneurons in the chick embryo spinal cord. III. The differentiation of motoneurons prior to their induced degeneration following limb-bud removal. *J Comp Neurol* 177:87-111.

Oppenheim RW, Prevet D, D'Costa A, Wang S, Houenou LJ, McIntosh JM (2000) Reduction of neuromuscular activity is required for the rescue of motoneurons from naturally occurring cell death by nicotinic-blocking agents. *J Neurosci* 20:6117-6124.

Orr-Urtreger A, Broide RS, Kasten MR, Dang H, Dani JA, Beaudet AL, Patrick JW (2000) Mice homozygous for the L250T mutation in the alpha7 nicotinic acetylcholine receptor show increased neuronal apoptosis and die within 1 day of birth. *J Neurochem* 74:2154-2166.

Pettmann B, Henderson CE (1998) Neuronal cell death. *Neuron* 20:633-647.

Picciotto MR, Zoli M (2002) Nicotinic receptors in aging and dementia. *J Neurobiol* 53:641-655.

Pilar G, Gray DB, Meriney SD (1996) Membrane delimited and intracellular soluble pathways in the somatostatin modulation of ACh release. *Life Sci* 58:1979-1986.

Pilar G, Nunez R, McLennan IS, Meriney SD (1987) Muscarinic and nicotinic synaptic activation of the developing chicken iris. *J Neurosci* 7:3813-3826.

Pittman R, Oppenheim RW (1979) Cell death of motoneurons in the chick embryo spinal cord. IV. Evidence that a functional neuromuscular interaction is involved in the

regulation of naturally occurring cell death and the stabilization of synapses. *J Comp Neurol* 187:425-446.

Pugh PC, Berg DK (1994) Neuronal acetylcholine receptors that bind alpha-bungarotoxin mediate neurite retraction in a calcium-dependent manner. *J Neurosci* 14:889-896.

Pugh PC, Margiotta JF (2000) Nicotinic acetylcholine receptor agonists promote survival and reduce apoptosis of chick ciliary ganglion neurons. *Mol Cell Neurosci* 15:113-122.

Purves D (1980) Neuronal competition. *Nature* 287:585-586.

Quik M, Chan J, Patrick J (1994) alpha-Bungarotoxin blocks the nicotinic receptor mediated increase in cell number in a neuroendocrine cell line. *Brain Res* 655:161-167.

Riethmacher D, Sonnenberg-Riethmacher E, Brinkmann V, Yamaai T, Lewin GR, Birchmeier C (1997) Severe neuropathies in mice with targeted mutations in the ErbB3 receptor. *Nature* 389:725-730.

Rogers M, Dani JA (1995) Comparison of quantitative calcium flux through NMDA, ATP, and ACh receptor channels. *Biophys J* 68:501-506.

Rogers M, Sargent PB (2003) Rapid activation of presynaptic nicotinic acetylcholine receptors by nerve-released transmitter. *Eur J Neurosci* 18:2946-2956.

Rohrer H, Thoenen H (1987) Relationship between differentiation and terminal mitosis: chick sensory and ciliary neurons differentiate after terminal mitosis of precursor cells, whereas sympathetic neurons continue to divide after differentiation. *J Neurosci* 7:3739-3748.

Role LW, Berg DK (1996) Nicotinic receptors in the development and modulation of CNS synapses. *Neuron* 16:1077-1085.

Rubel EW, Hyson RL, Durham D (1990) Afferent regulation of neurons in the brain stem auditory system. *J Neurobiol* 21:169-196.

Ruit KG, Elliott JL, Osborne PA, Yan Q, Snider WD (1992) Selective dependence of mammalian dorsal root ganglion neurons on nerve growth factor during embryonic development. *Neuron* 8:573-587.

Sargent PB (1993) The diversity of neuronal nicotinic acetylcholine receptors. *Annu Rev Neurosci* 16:403-443.

Schoepfer R, Conroy WG, Whiting P, Gore M, Lindstrom J (1990) Brain alpha-bungarotoxin binding protein cDNAs and MAbs reveal subtypes of this branch of the ligand-gated ion channel gene superfamily. *Neuron* 5:35-48.

Sechrist JW, Wolf J, Bronner-Fraser M (1998) Age-dependent neurotransmitter plasticity of ciliary ganglion neurons. *Mol Cell Neurosci* 12:311-323.

Shoop RD, Martone ME, Yamada N, Ellisman MH, Berg DK (1999) Neuronal acetylcholine receptors with alpha7 subunits are concentrated on somatic spines for synaptic signaling in embryonic chick ciliary ganglia. *J Neurosci* 19:692-704.

Shoop RD, Esquenazi E, Yamada N, Ellisman MH, Berg DK (2002) Ultrastructure of a somatic spine mat for nicotinic signaling in neurons. *J Neurosci* 22:748-756.

Smeyne RJ, Klein R, Schnapp A, Long LK, Bryant S, Lewin A, Lira SA, Barbacid M (1994) Severe sensory and sympathetic neuropathies in mice carrying a disrupted *Trk/NGF* receptor gene. *Nature* 368:246-249.

Snider WD (1994) Functions of the neurotrophins during nervous system development: what the knockouts are teaching us. *Cell* 77:627-638.

Sorenson EM, Shiroyama T, Kitai ST (1998) Postsynaptic nicotinic receptors on dopaminergic neurons in the substantia nigra pars compacta of the rat. *Neuroscience* 87:659-673.

Sperry DG, Grobstein P (1985) Regulation of neuron numbers in *Xenopus laevis*: effects of hormonal manipulation altering size at metamorphosis. *J Comp Neurol* 232:287-298.

Summers KL, Giacobini E (1995) Effects of local and repeated systemic administration of (-)-nicotine on extracellular levels of acetylcholine, norepinephrine, dopamine, and serotonin in rat cortex. *Neurochem Res* 20:753-759.

Tanaka H, Landmesser LT (1986) Cell death of lumbosacral motoneurons in chick, quail, and chick-quail chimera embryos: a test of the quantitative matching hypothesis of neuronal cell death. *J Neurosci* 6:2889-2899.

Thanos S, Bonhoeffer F (1984) Development of the transient ipsilateral retinotectal projection in the chick embryo: a numerical fluorescence-microscopic analysis. *J Comp Neurol* 224:407-414.

Treinin M, Chalfie M (1995) A mutated acetylcholine receptor subunit causes neuronal degeneration in *C. elegans*. *Neuron* 14:871-877.

Ullian EM, McIntosh JM, Sargent PB (1997) Rapid synaptic transmission in the avian ciliary ganglion is mediated by two distinct classes of nicotinic receptors. *J Neurosci* 17:7210-7219.

Usiak MF, Landmesser LT (1999) Neuromuscular activity blockade induced by muscimol and d-tubocurarine differentially affects the survival of embryonic chick motoneurons. *J Neurosci* 19:7925-7939.

Vernallis AB, Conroy WG, Berg DK (1993) Neurons assemble acetylcholine receptors with as many as three kinds of subunits while maintaining subunit segregation among receptor subtypes. *Neuron* 10:451-464.

Vidal C, Changeux JP (1989) Pharmacological profile of nicotinic acetylcholine receptors in the rat prefrontal cortex: an electrophysiological study in a slice preparation. *Neuroscience* 29:261-270.

Vijayaraghavan S, Huang B, Blumenthal EM, Berg DK (1995) Arachidonic acid as a possible negative feedback inhibitor of nicotinic acetylcholine receptors on neurons. *J Neurosci* 15:3679-3687.

Wada E, Wada K, Boulter J, Deneris E, Heinemann S, Patrick J, Swanson LW (1989) Distribution of alpha 2, alpha 3, alpha 4, and beta 2 neuronal nicotinic receptor subunit mRNAs in the central nervous system: a hybridization histochemical study in the rat. *J Comp Neurol* 284:314-335.

Wang GK, Schmidt J (1976) Receptors for alpha-bungarotoxin in the developing visual system of the chick. *Brain Res* 114:524-529.

Wooltorton JR, Pidoplichko VI, Broide RS, Dani JA (2003) Differential desensitization and distribution of nicotinic acetylcholine receptor subtypes in midbrain dopamine areas. *J Neurosci* 23:3176-3185.

Wright L (1981) Cell survival in chick embryo ciliary ganglion is reduced by chronic ganglionic blockade. *Brain Res* 227:283-286.

Yu CR, Role LW (1998) Functional contribution of the alpha7 subunit to multiple subtypes of nicotinic receptors in embryonic chick sympathetic neurones. *J Physiol* 509 (Pt 3):651-665.

Zago WM, Massey KA, Berg DK (2006) Nicotinic activity stabilizes convergence of nicotinic and GABAergic synapses on filopodia of hippocampal interneurons. *Mol Cell Neurosci* 31:549-559.

Zhang ZW, Vijayaraghavan S, Berg DK (1994) Neuronal acetylcholine receptors that bind alpha-bungarotoxin with high affinity function as ligand-gated ion channels. *Neuron* 12:167-177.

Zhang ZW, Coggan JS, Berg DK (1996) Synaptic currents generated by neuronal acetylcholine receptors sensitive to alpha-bungarotoxin. *Neuron* 17:1231-1240.

Zoli M, Lena C, Picciotto MR, Changeux JP (1998) Identification of four classes of brain nicotinic receptors using beta2 mutant mice. *J Neurosci* 18:4461-4472.

Zorumski CF, Olney JW (1993) Excitotoxic neuronal damage and neuropsychiatric disorders. *Pharmacol Ther* 59:145-162.

CHAPTER 2

CELL-AUTONOMOUS INHIBITION OF $\alpha 7$ CONTAINING NICOTINIC ACETYLCHOLINE RECEPTORS PREVENTS DEATH OF PARASYMPATHETIC NEURONS DURING DEVELOPMENT

Martin Hruska and Rae Nishi

Department of Anatomy and Neurobiology
University of Vermont College of Medicine
Burlington, VT 05405

Corresponding Author:

Rae Nishi
Dept. Anatomy and Neurobiology
149 Beaumont Ave.
Burlington, VT 05405
Voice: 802-656-4504
Email: rnishi@uvm.edu

Abbreviated Title: $\alpha 7$ -nAChR Mediated Cell Death of Ciliary Ganglion Neurons

Number of Figures and Tables: 6 Figures, 0 Tables

Supplemental Material: Supplementary Figure 1.

Number of Pages: 49

Number of words for Abstract/Introduction/Discussion: 246/493/1495

Key words: Glycosylphosphatidylinositol, α -bungarotoxin, RCAS, calcium imaging, ciliary ganglion, retrovirus

Acknowledgments: We thank Drs. Ines Ibanez-Tallon and Nathaniel Heintz for providing us with the GPI- α btx construct. We are also grateful to Drs. Rodney Parsons, Victor May, Jennifer Straub, and Steven Straub for their comments on our manuscript.

ABSTRACT

Neurotrophic molecules are key retrograde influences of cell survival in the developing nervous system, but other influences such as activity are also emerging as important factors. In the avian ciliary ganglion, half the neurons are eliminated between embryonic days 8 and 14, but it is not known how cell death is initiated. Since systemic application of $\alpha 7$ -nicotinic acetylcholine receptor (nAChR) antagonists prevents this cell loss, we examined differences in receptor densities and responses of intracellular calcium to nicotine using the calcium-sensitive dye Fura-2. In addition, we determined whether cell autonomous inhibition of $\alpha 7$ activation in neurons prevented cell death. E8 neurons are heterogeneous with respect to $\alpha 7$ -nAChR density, which leads to large increases in $[Ca^{2+}]_i$ in some neurons; E8 neurons also exhibit a slower rate of Ca^{2+} decay after nicotinic stimulation than E13 neurons. Expressing α -bungarotoxin that is tethered to the membrane by a glycosylphosphatidylinositol linkage (GPI α btx) in ciliary ganglion neurons with the retroviral vector RCASBP(A) blocks increases in intracellular calcium induced by nicotine through $\alpha 7$ -nAChRs and prevents neurons from dying. Expression of GPI α btx in surrounding non-neural tissues, but not in neurons, does not prevent cell loss. Furthermore, the GPI α btx is not efficiently expressed in the accessory oculomotor neurons, eliminating preganglionic inputs as another site for action of the antagonist. These results support the hypothesis that cholinergic inputs facilitate cell death in the developing autonomic nervous system by activating $\alpha 7$ -nAChRs, possibly by leading to increases in intracellular calcium that exceed the threshold for cell survival.

INTRODUCTION

The phenomenon of cell death of post-mitotic neurons in the developing vertebrate nervous system has been well described but the means by which cell death is induced are not well understood (Oppenheim, 1991). Up to 70% of neurons are lost at the time of synapse formation with their targets, during which neurons are dependent upon target-derived factors for survival (Davies, 1996). The neurotrophic hypothesis proposes that neurons die because they fail to compete effectively for a limited amount of trophic factor in the target tissue. Both gain and loss of function studies show that many target-derived factors are essential for supporting neuronal survival (Snider, 1994); however, neurons integrate trophic support from more than one source (target and glia) and to do this, they must enter the competition with some advantage involving cell-to-cell differences in intrinsic factors, like surface receptor expression (Pettmann and Henderson, 1998). This suggests that the trophic requirements of neurons are more complex and other signals may also be involved in controlling cell death (Eisen and Melancon, 2001).

The ciliary ganglion, a parasympathetic ganglion that innervates the iris, ciliary muscle, and choroidal vasculature in the avian eye (Marwitt et al., 1971), undergoes a period of target-dependent cell loss between E8 and E14 (Landmesser and Pilar, 1974a). However, virtually all ciliary ganglion neurons are rescued from dying by daily application of $\alpha 7$ subunit-containing nAChR-specific antagonists to the chorioallantoic membrane between E8 and E14 without changes in trophic factor availability or access at target tissues

(Meriney et al., 1987; Bunker and Nishi, 2002). This suggests that activation of $\alpha 7$ -nAChRs can facilitate cell death independently of the competition for target-derived factors. However, the site at which these antagonists act is not clear because they were delivered throughout the entire chicken embryo.

$\alpha 7$ -nAChRs are cation-selective channels that are highly expressed together with heteromeric nAChRs containing $\alpha 3$, $\alpha 5$, $\beta 4$ and sometimes $\beta 2$ subunits on ciliary ganglion neurons, where they mediate excitatory transmission (Zhang et al., 1996; Chang and Berg, 1999). In addition, $\alpha 7$ -nAChR have high relative permeability to Ca^{2+} that rivals that of NMDA receptors but, unlike NMDA receptors, $\alpha 7$ -nAChRs can mediate Ca^{2+} influx at resting or hyperpolarized potentials (Role and Berg, 1996a). This feature enables them to influence a variety of Ca^{2+} -dependent events, including gene expression, neurite retraction, axonal pathfinding and cell death (Pugh and Berg, 1994; Zheng et al., 1994; Berger et al., 1998a; Chang and Berg, 2001b; Liu et al., 2006).

This study was undertaken to determine whether activation of $\alpha 7$ -nAChRs on ciliary ganglion neurons causes cell death. To do this, we used α -bungarotoxin tethered to the membrane by glycosylphosphatidylinositol (GPI) linkage (Ibanez-Tallon et al., 2004), to determine whether cell-autonomous inhibition of $\alpha 7$ -nAChRs prevents both ciliary and choroid neurons from dying. We also examine differences in Ca^{2+} signaling between neurons prior to cell death, and propose a possible mechanism of $\alpha 7$ -nAChR-induced cell

death through Ca^{2+} overload. Our findings highlight the importance of non-traditional roles of nAChRs during neural development.

MATERIALS AND METHODS

Isolation of neurons: Ciliary ganglia were isolated and dissociated for imaging, staining, and flow cytometry from E6-E10 embryos as previously described (Nishi, 1996). E13 ciliary ganglia were dissociated by incubating in Earle's Balanced Salt Solution (EBSS) containing 1 mg/ml collagenase type 2 (Cat # 4176, Worthington, Lakewood, NJ), 1 mg/ml hyaluronidase (Cat # 2592, Worthington), and 10 mg/ml bovine serum albumin (Sigma, St. Louis, MO) for 15 min at 37°C. The activity of the proteases was terminated by dilution, then the supernatant was removed and ganglia were incubated in EBSS containing 3 mg/ml trypsin (Cat # 3703, Worthington) for 3 min at 37°C. Ciliary ganglia were triturated until completely dissociated. Following dissociation, cells were pre-plated on the plastic surface for 30 min at 37°C in order to remove adherent cells (fibroblast and glia). Neurons were plated on poly-D-lysine/laminin coated coverslips in complete medium consisting of Dulbecco's Modified Eagle Medium (DMEM, Invitrogen, Carlsbad, CA) containing 10% (v/v) heat-inactivated horse serum (Invitrogen), 2% (v/v) fetal calf serum (Atlanta Biologicals, Lawrenceville, GA), 2% (v/v) chicken eye extract with 50 U/ml penicillin, 50 mg/ml streptomycin, and 2 mM glutamine (Invitrogen). Neurons were used for staining or calcium imaging after allowing them to attach to the coverslip for 2 hrs after plating. Alternatively, acutely isolated neurons were incubated with α -bungarotoxin-Alexa 488 or Q211 and immediately processed for flow cytometry as described below.

Immunostaining and live cell labeling: Dissociated E8 or E13 neurons were incubated while alive with Alexa 488 conjugated α btx (Invitrogen) diluted 1:500 in complete medium for 30 min at 37°C or with rabbit anti- α btx, diluted 1:1000 in complete medium for 30 min on ice, in order to label only cell surface molecules. Following the incubation, neurons were washed 3x in EBSS and fixed in Zamboni's fixative (4% paraformaldehyde, 15% picric acid in 0.1 M sodium phosphate, pH 7.4) for 2 hr at 4°C. Coverslips were washed with phosphate buffered saline (PBS; 137 mM NaCl, 20 mM sodium phosphate, pH 7.4), blocked overnight in blocking buffer (PBS + 0.5% (v/v) TritonX-100 containing 5% (v/v) horse serum) at 4°C, then incubated overnight in primary antibodies. Secondary antibodies were incubated for 1-2 hrs at room temperature.

Tissues were prepared for immunohistochemistry as follows: Ciliary ganglia and brainstems from E14 embryos were harvested, fixed in Zamboni's for 48 hours at 4°C, washed, then equilibrated in 30% sucrose at 4°C. Tissue was embedded in Microm cryo-embedding compound (Richard Allen Scientific, Kalamazoo, MI), sectioned on a Microm HM 560 cryostat (Richard Allen Scientific) at 30 μ m, and collected on Superfrost Plus slides (Fisher Scientific, Pittsburgh, PA). Sections were post-fixed in Zamboni's vapors for 15 min at 37°C, submerged in Zamboni's fixative for additional 15 min at 25°C, washed in PBS and blocked. Primary antibodies were incubated overnight at 4°C and secondary antibodies were incubated 2 hr at room temperature.

Primary antibodies and the dilutions in blocking buffer at which they were used were: anti-mouse AMV-3C2 (Developmental Studies Hybridoma Bank (DSHB), Iowa City, Iowa), which recognizes a viral p19 gag expressed by avian sarcoma and leukemia viruses (Potts et al., 1987) at 1:10; mouse anti-Islet-1, which recognizes a transcription factor expressed in ciliary ganglion neurons (Lee et al., 2001) at 1:100 dilution of the culture supernatant (prepared in the Nishi Lab from clone 39.4D5, DSHB); mouse anti-Hu C/D (Invitrogen), which recognizes a neuron-specific RNA binding protein (Marusich and Weston, 1992; Lee et al., 2001) at 1:250 dilution of the culture supernatant; rabbit anti-p27gag (SPAFAS, Norwich, CT), which recognizes avian sarcoma gag p27 (Wang et al., 1976) at 1:1000; rat anti-somatostatin (Product #: YMC1020, Accurate Chemical & Scientific corporation, Westbury, NY) diluted 1:100, and rabbit anti- α btx at 1:1000 (a generous gift from Dr. Joshua Sanes, Washington University (now at Harvard University), whose specificity is shown in Supplementary Figure 1).

Secondary antibodies: biotinylated anti-mouse (Vector Laboratories, Burlingame, CA) at 1:250; biotinylated anti-rabbit (Vector Laboratories) at 1:250; goat anti-mouse Cy3 (Jackson Immuno Research, West Grove, PA) at 1:750; goat anti-rabbit Alexa 488 (Invitrogen) at 1:750; and goat anti-rat Cy3 (Jackson Immuno Research) at 1:750. Images of dissociated neurons were acquired with 60x objective on DeltaVision (Olympus IX70) deconvolution microscope (Applied Precision, Inc., Issaquah, WA) using a CoolSNAP HQ CCD camera (Photometrics, Tucson, AZ). Image stacks were deconvolved using softWoRx image analysis software version 3.5.1 (Applied Precision,

Inc.). Images of ciliary ganglia and midbrain were acquired with 20x objective using Nikon C1 confocal scanner (Nikon Instruments Inc., Melville, NY) attached to a Nikon Eclipse E800 microscope (Micro Video Instruments, Avon, MA).

Flow Cytometry: Dissociated neurons were labeled live with 1:500 α btx-Alexa 488 and 1:3000 mouse anti-Q211 (kindly provided by Dr. Herman Rohrer), which recognizes a neuron-specific ganglioside (Rohrer et al., 1985). Q211 immunoreactivity was visualized with goat F(ab')₂ anti-mouse IgG conjugated to PE-Cy5.5 (Caltag Laboratories, Burlingame, CA) diluted 1:200. At each developmental stage examined, 40,000 cells were analyzed for their surface α 7-nAChR levels by flow cytometry using a Coulter Epics XL Analyzer (Coulter Corporation, Miami, FL). Generated scatter plots indicated the relative levels of α btx-Alexa 488 binding of all Q211 positive cells.

Expression of GPI α btx with a viral vector: An α -bungarotoxin that is tethered to the membrane via a glycosylphosphatidyl-inositide linkage (GPI α btx) was a gift from Drs. Inez Ibanez-Tallon and Nathaniel Heintz, Rockefeller University (Ibanez-Tallon et al., 2004). The GPI α btx sequence was cloned into the Slax13NCO1 shuttle vector using 5' Nco1 and 3' EcoR1 sites (Morgan and Fekete, 1996); the insert was removed from Slax13NCO1 by cutting with Cla1, and cloned into the avian retroviral vector RCASBP(A) (Federspiel and Hughes, 1997). Infective RCASBP(A)-GPI- α btx viral particles were generated by transfecting DF-1 chicken fibroblast cells with 800 ng of RCASBP(A)-GPI α btx plasmid using Mirus TransIT-LT transfection reagent (Mirus Bio Corporation, Madison, WI). Conditioned media containing viral stocks collected from

DF-1 cells were concentrated approximately 20-fold by ultracentrifugation at 90,000 x g at 4°C for 3 hr (Morgan and Fekete, 1996). Concentrated stocks were titered by limiting dilution and infectivity of cells as measured by staining with p27gag antibody. Stocks with concentration of $>10^8$ infectious particles/ml were used for *in vivo* injection. Viral particles (60-120 nL) were injected into the mesencephalic enlargement of the neural tube of Hamburger/Hamilton stage (St.) 8-9 or St. 10-13 embryos using a Drummond Nanoject microinjector (Drummond Scientific, Broomall, PA). The shells were sealed with a glass coverslip and sterile vacuum grease and incubated at 37°C to the desired stage.

Calcium imaging: Acutely isolated ciliary ganglion neurons were loaded with Fura-2 AM (Invitrogen) dissolved in DMSO at final concentration of 5 μ M with 2% Pluronic F-127 (Invitrogen). Neurons were loaded at room temperature for 30 min in the dark. Calcium signals were recorded by exposure to alternating wavelength (340 and 380 nm, 50 ms) generated by a Xenon light source and Lambda DG-4 ultra high-speed wavelengths switcher (Sutter Instruments, Novato, CA). Fluorescent responses were recorded using an Orca-ER digital camera (Hamamatsu, Bridgewater, NJ). Paired 340/380 ratio images were acquired at 4s intervals with Metaflour 5.0r5 software (Molecular Devices Corp, Downingtown, PA). Drugs were dissolved in chicken physiological buffer (145 mM NaCl, 5.4 mM KCl, 0.8 mM MgCl₂, 5.4 mM CaCl₂, 5 mM glucose, 13 mM HEPES, pH 7.4). Voltage gated sodium and calcium channels were blocked by supplementing the perfusion medium with 600 nM tetrodotoxin (Tocris, Ellisville, MO) and 200 μ M cobalt

chloride (Sigma), respectively. 10 μ M Nicotine (Sigma) was applied for 20 sec to activate nAChRs. α 7-nAChRs were inhibited by perfusing the neurons with 50 nM α -methyllycaconitine citrate hydrate (MLA) (Sigma) for 1min or pre-incubating with 50 nM α btx (Sigma) for 30 min at 25°C. Heteromeric α 3/ α 5/ β 4/ β 2 (α 3*)-nAChRs were blocked by perfusing neurons for 1 min with 5 μ M Dihydro- β -erythroidine hydrobromide (DH β E; Sigma). Upon completion of these experiments, the extent of dye loading was determined by activating voltage-gated calcium channels with high potassium perfusion solution (25 mM KCl, with no TTX or cobalt chloride).

Analysis of Ca²⁺ imaging data: After the initial recordings were performed, background was subtracted from every image acquired and new ratios were calculated using the Metafluor 5.0r5 software. The ratios were then exported into the Microsoft Excel spreadsheet and all the calculations were performed using Microsoft Excel. For the calculation of Ca²⁺ decay rates, traces were normalized so that the baseline was always 0 and the peak calcium signal was always 1, using the equation $(F-F_0)/F_{\text{peak}}$. Baseline fluorescence (F_0) was subtracted from the fluorescence at every time point (F). This value was then divided by peak amplitude fluorescence (F_{peak}). This allowed us to observe changes in the rate of Ca²⁺ decay between individual neurons.

Design-based stereology: Serially sectioned ciliary ganglia (cut at 30 μ m) were prepared for design-based stereology as previously described (Bunker and Nishi, 2002) and Islet-1 positive nuclei (representing all neurons) together with somatostatin-positive cell

bodies (representing all choroid neurons) were counted using the Optical Dissector Probe of Stereo Investigator (MBF Biosciences, Williston, VT) in conjunction with a Nikon Optiphot 2 microscope with a Hitachi HVC20 camera, Heidenhahn focus encoder, and a motorized, computer-driven X, Y, Z stage (all microscope attachments provided by MBF Biosciences). To avoid inaccuracies caused by cutting artifacts and double counting between adjacent sections, an upper guard of 4 μm and lower guard of 7 μm were used (Bunker and Nishi, 2002). Spacing between sampling sites (grid size) was set such that 13-15 sampling sites were counted per section, which yielded 100-300 objects per each ciliary ganglion. The number of ciliary neurons was calculated by subtracting the number of somatostatin-positive neurons from the total number of neurons per ciliary ganglion (Bunker and Nishi, 2002).

RESULTS

Immature ciliary ganglion neurons express heterogeneous levels of $\alpha 7$ -nAChRs

If cell death in the ciliary ganglion is triggered in some neurons but not others *in vivo* between E7 and E9 by excessive signaling through $\alpha 7$ subunit containing nAChRs, then there should be heterogeneity in $\alpha 7$ -nAChR expression between individual neurons, where the neurons with high levels of surface $\alpha 7$ -nAChRs would be especially at risk to die from high Ca^{2+} influx through these receptors. To label surface $\alpha 7$ -nAChRs, αbtx -Alexa 488 was bound to live ciliary ganglion neurons at E8. Individual E8 neurons exhibit different intensities of staining with αbtx -Alexa 488 (Fig. 1A). One example of $\alpha 7$ -nAChR heterogeneity is shown in figure 1A, where a neuron indicated by arrow labels brightly with αbtx -Alexa 488, while neighboring neurons display a low level of αbtx -Alexa 488 binding (arrowhead in Fig. 1A).

At E13, we identified acutely isolated neurons as choroid or ciliary based on somatostatin immunoreactivity (Epstein et al., 1988; Coulombe et al., 1993). Both ciliary and choroid neurons express high levels of surface $\alpha 7$ -nAChRs (Fig. 1B,C). Moreover, $\alpha 7$ -nAChRs on somatostatin-negative, ciliary neurons are found tightly clustered on somatic spines at this developmental stage, which is another sign of maturation (arrows in Fig. 1B, Shoop et al, 1999). Choroid neurons that express somatostatin do not show $\alpha 7$ -nAChR

clustering (Fig. 1C). Qualitatively, the intensity of staining with α btx-Alexa 488 does not differ between individual E13 neurons of each population.

To survey the number of neurons exhibiting different levels of α btx-Alexa 488 binding at various stages of development across ganglia, we used flow cytometry (Fig. 1D-G).

Neurons were distinguished from non-neuronal cells by immunoreactivity to Q211, an antibody that recognizes a neuron-specific ganglioside shortly after neural progenitors have commenced differentiation (Rohrer et al., 1985). At E6 and E7, neurons (Q211 positive cells) are very heterogeneous with respect to their surface α btx binding, as can be seen by the large amount of scatter in α btx labeling intensities (Fig. 1D,E). By E9, the Q211 positive cells with little or no α btx binding have all begun to express α 7-nAChRs, and a few neurons still display very high α btx binding (arrowhead, Fig. 1F). However, by E10, α btx binding is much more homogeneous than at E6 and E7 (Fig. 1G). The loss of Q211 immunoreactivity, as seen by the spread of α btx-positive cells into the upper left quadrant (Fig. 1F,G) is a normal progression of Q211 staining that we have observed as neurons mature.

Because α 7-nAChRs have a high relative permeability to calcium equal to that of NMDA receptors (Role and Berg, 1996a), we tested whether the heterogeneity in surface α 7-nAChRs observed at E8 leads to larger increases in intracellular Ca^{2+} in some neurons versus others. Neurons were imaged using the ratiometric dye fura-2 and 10 μM nicotine was applied by perfusion to activate the maximum number of nAChRs in all the neurons

imaged by the microscope. By doing so, we could collect data on a large number of neurons per experiment, which is not possible by single cell electrophysiology. To ensure that only nicotinic Ca^{2+} responses were measured, 200 μM CoCl_2 and 600 nM tetrodotoxin (TTX) were added to the perfusion buffer in order to inhibit voltage-gated calcium and sodium channels, respectively (see Materials and Methods).

First, we tested whether neurons could recover nAChR sensitivity after nicotine application so that the efficacy of antagonists could be tested. After the first application of nicotine (Nic1), we washed cells for 5 min, and then perfused nicotine again (Nic2, Fig. 2A). The peak amplitude of the Ca^{2+} response after second stimulation was not significantly different from the initial application of nicotine (Fig. 2B). Therefore, in all subsequent experiments we washed for at least 5 minutes after the initial application of nicotine before we applied nicotine together with nicotinic antagonists. The response elicited by nicotine could be significantly reduced by 50 nM MLA, an antagonist known to selectively block $\alpha 7$ -nAChRs on ciliary ganglion neurons at this concentration (Alkondon et al., 1992); Fig. 2C, $p < 0.0001$; one-way ANOVA, $n = 34$ neurons). The residual response was completely blocked with a cocktail containing 50 nM MLA and 5 μM Dihydro- β -erythroidine hydrobromide (DH β E; Fig. 2C, compare MLA with DH β E/MLA, $p < 0.0001$; one-way ANOVA, $n = 30$ neurons), which completely blocks transmission through the ciliary ganglion (Bertrand et al., 1992; Liu et al., 2006).

We then examined whether there are differences in $\alpha 7$ -nAChR-induced Ca^{2+} influx between ciliary ganglion neurons isolated at different stages of development. To determine the Ca^{2+} influx mediated by $\alpha 7$ -nAChR, Ca^{2+} responses obtained in the presence of the $\alpha 7$ -nAChR specific antagonist MLA were subtracted from the total Ca^{2+} responses to 10 μM nicotine. When E8 neurons are stimulated with nicotine, the elicited Ca^{2+} responses have a broad distribution (Fig. 2D), demonstrating that individual E8 neurons exhibit variability in Ca^{2+} influx through $\alpha 7$ -nAChRs. Compared to E8 neurons, $\alpha 7$ -specific Ca^{2+} responses at E9 are skewed to the left with the majority of responses clustered around the mean (Fig. 2D). The mean of $\alpha 7$ -nAChR-specific Ca^{2+} responses at E9 is significantly smaller compared to E8 neurons ($p < 0.0002$, Student t-test, E8: 0.09 ± 0.007 , $n=41$; E9: 0.06 ± 0.004 , $n=80$). At E13, which is near the end of the cell death period, only half of the ciliary ganglion neurons display increases in intracellular calcium in response to perfused nicotine, despite the fact that all of them respond to high K^+ , indicating that all cells are equally loaded with Fura-2. Of the ones that respond, intracellular Ca^{2+} decays to baseline at much faster rate than in neurons isolated at E8 (before onset of neuronal loss; Fig. 2E). At E8 the rate of Ca^{2+} decay can be fitted with a single exponential ($\tau=48.9 \pm 0.98\text{s}$) while the rate of Ca^{2+} decay at E13 can be fitted with double exponential, with initial fast decay ($\tau_1=17.5 \pm 0.42\text{s}$) and later slower decay ($\tau_2=175.6 \pm 91.4\text{s}$), suggesting that an additional mechanism for sequestering intracellular calcium has developed. Treatment with MLA eliminates differences in the rate of Ca^{2+} decay between E8 and E13 neurons; at both stages the rate of Ca^{2+} decay can be fitted with a double exponential equation (Fig. 2F; E8: $\tau_1=27.9 \pm 0.0005\text{s}$, $\tau_2=1014.1\text{s}$; E13:

$\tau_1=20.7\pm 1.56s$, $\tau_2=78.8\pm 26.1s$). These results suggest that the activation of $\alpha 7$ -nAChRs influences how neurons handle increases in $[Ca^{2+}]_i$.

Membrane-tethered α -bungarotoxin inhibits $\alpha 7$ -nAChR mediated Ca^{2+} influx in ciliary ganglion neurons

In order to block Ca^{2+} influx via $\alpha 7$ -nAChRs cell-autonomously *in vivo*, we used the avian retroviral vector RCASBP(A) to express an α btx that was modified at the C-terminus to include a linker with a consensus sequence for the glycosylphosphatidylinositol linkage from mouse lynx-1 (Fig. 3A; (Ibanez-Tallon et al., 2004). Ciliary ganglion neurons infected with this construct exhibit bright, punctate α btx immunoreactivity on their cell surface, indicating efficient expression of tethered α btx (Fig. 3C). When the ciliary ganglion cultures are prepared from embryos infected with the control (open) virus, neurons do not label with α btx antibody (Fig. 3B). The specificity of α btx antibody was confirmed by western blot and ELISA (Supplementary Fig. 1).

To test whether GPI α btx blocks Ca^{2+} influx through $\alpha 7$ -nAChRs, E8 ciliary ganglion neurons infected either with GPI α btx or open virus were subjected to Ca^{2+} imaging as described above. GPI α btx-infected neurons have significantly reduced nicotinic Ca^{2+} responses compared to the neurons infected with control virus (Fig. 3D; open: 1.29 ± 0.13 , n=21; GPI α btx: 0.36 ± 0.06 , n=23, $P<0.0001$, Student t-test). In fact, GPI α btx

inhibits nicotine-induced increases in intracellular Ca^{2+} to the same extent as exogenously applied αbtx (Fig. 3D; open+ αbtx : 0.19 ± 0.04 , n=7; GPI αbtx : 0.36 ± 0.06 , n=23).

Moreover, applying exogenous αbtx (50 nM) to GPI αbtx infected cultures does not cause additional reduction in Ca^{2+} influx (Fig. 3D; GPI αbtx : 0.36 ± 0.06 , n=23; GPI αbtx + 50 nM αbtx : 0.30 ± 0.05 , n=6). The above findings indicate that tethered αbtx inhibits $\alpha 7$ -nAChR mediated increases in intracellular Ca^{2+} .

Expression of the GPI αbtx does not eliminate all of the calcium influx, leaving behind the residual Ca^{2+} response (Fig. 3D), which is very similar to the residual response observed after a treatment with MLA (Fig. 2C). This residual response is eliminated by the treatment with DH β E (Fig. 2C), an antagonist that is more selective for heteromeric $\alpha 3^*$ -nAChRs. Treatment of GPI αbtx infected neurons with exogenous αbtx does not cause further reduction in the residual Ca^{2+} response (Fig. 3D).

To determine if the GPI αbtx can be spontaneously released from the surface of a neuron and bind to $\alpha 7$ -nAChRs on nearby neurons, we co-incubated uninfected ciliary ganglion neurons overnight with the neurons infected with the GPI αbtx (Fig. 4). The cultures were then live-labeled with αbtx -Alexa 488 to visualize unoccupied surface $\alpha 7$ -nAChRs. Uninfected neurons label strongly with αbtx -Alexa 488, while neurons infected with GPI αbtx retrovirus do not label with αbtx -Alexa 488 (Fig. 4B,C). Importantly, uninfected neurons that were co-incubated with the GPI αbtx -infected neurons still exhibit intense αbtx -Alexa 488 labeling that is comparable to uninfected controls (Fig.

4D), demonstrating that their $\alpha 7$ -nAChRs are not occupied by α btx clipped off the surface of GPI α btx-infected neurons.

GPI α btx rescues ciliary and choroid neurons from cell death.

To block activation of $\alpha 7$ -nAChRs on ciliary ganglion neurons *in vivo*, we infected chicken embryos with RCASBP(A)-GPI α btx and counted the number of surviving neurons at E14 using design-based stereology (Bunker and Nishi, 2002). If the viral particles are injected into the mesencephalon at St. 8-9 (36 hours of development), ciliary ganglion neurons precursors are still present at the neural tube and accessible to retroviral infection (Fig. 5A-C). However, if viral particles are injected at St. 10-13, the precursors have already migrated away from the neural tube to form a ganglion and are therefore inaccessible to the retrovirus, resulting in uninfected neurons surrounded by infected non-neuronal cells (Fig. 5D-F).

For counting purposes, ciliary ganglia were labeled with Islet-1 and somatostatin antibodies (Fig. 5G). Infection with GPI α btx at 36 hours of development rescues 41% of ciliary ganglion neurons from cell death compared to control-infected ganglia (Fig. 5H, $p < 0.001$, ANOVA; open ganglia: 6459 neurons, $n=6$; GPI α btx ganglia: 11,310 neurons, $n=8$). Moreover, both ciliary ($p < 0.01$) and choroid neurons are rescued (Fig. 5H, $p < 0.001$, ANOVA with Tukey's multiple comparison post hoc). When neurons are not infected, but surrounding non-neuronal cells are with RCASBP(A)-GPI α btx, then

neuronal cell numbers are not significantly different from open-infected control ciliary ganglia (Fig. 5H, GPI α btx ganglia infected at 48 hr: 8250 neurons, n=9). Thus, the GPI α btx must be expressed in ciliary ganglion neurons to block cell death. These results also show that GPI α btx is not released from cells in quantities sufficient to block α 7 nAChRs on nearby neurons.

The ciliary ganglion receives preganglionic input from the accessory oculomotor nucleus (AON) in the midbrain. The preganglionic neurons also contain presynaptic α 7-nAChRs that control the release of acetylcholine by increasing the Ca²⁺ influx into the presynaptic terminals (Coggan et al., 1997; Rogers and Sargent, 2003). Therefore, inhibition of these receptors with GPI α btx could also affect survival of ciliary ganglion neurons. However, p27gag immunoreactivity is observed only in a small number of AON neurons (arrows in Fig. 6A-C), indicating that preganglionic neurons do not express GPI α btx. Thus, presynaptic α 7-nAChRs in terminals from AON are unlikely to affect survival of ciliary ganglion neurons.

DISCUSSION

The principal findings reported here support the hypothesis that $\alpha 7$ -nAChRs facilitate developmental cell death of parasympathetic neurons, possibly by allowing increases in intracellular calcium that exceed the threshold for cell survival. Shortly after all of the neurons in the ciliary ganglion are innervated by preganglionic inputs, neurons express variable levels of $\alpha 7$ -nAChRs together with differences in $\alpha 7$ -mediated increases in intracellular calcium induced by nicotine. Furthermore, intracellular increases in calcium fall to baseline levels at slower rates in young neurons when compared to neurons that have survived the cell death period. Finally, cell-autonomous inhibition of $\alpha 7$ -nAChR signaling prevents cell death. Thus, anterograde signals play an important role in sculpting the final number of neurons in the autonomic nervous system.

The conclusion that activation of $\alpha 7$ -nAChRs on ciliary ganglion neurons facilitates normal neuronal loss in the ganglion is based on the cell-autonomous action of GPI α btx. The utility of this reagent *in vivo* was first demonstrated in zebrafish striated muscle; also in these studies, *Xenopus* oocytes expressing the GPI α btx co-incubated with oocytes expressing $\alpha 7$ -nAChRs did not block $\alpha 7$ responses, demonstrating that the toxin was not cleaved and acting non-cell autonomously (Ibanez-Tallon et al., 2004). We show similar results when neurons expressing GPI α btx are co-cultured with uninfected neurons. Importantly, *in vivo*, we fail to rescue neurons when the GPI α btx is expressed only in surrounding non-neuronal cells; the construct must be in neurons to rescue them.

However, at present time we cannot distinguish between $\alpha 7$ -nAChRs located in cell soma and the terminals of ciliary ganglion neurons. RCASBP(A) does not efficiently infect early neural progenitors in the neural tube, therefore, GPI α btx is poorly expressed on the preganglionic neurons in the midbrain. Thus, presynaptic $\alpha 7$ -nAChRs in GPI α btx-infected embryos are not affected. This observation excludes $\alpha 7$ -nAChRs on neurons in the accessory oculomotor nucleus as a significant contributor to cell death of ciliary ganglion neurons.

The hypothesis that $\alpha 7$ -nAChR activation facilitates cell death of ciliary ganglion neurons is consistent with the temporal sequence of ganglionic innervation. Afferents from the AON first make contact at E4.5 and the neurons are 100% functionally innervated by E8, prior to the onset of cell loss (Landmesser and Pilar, 1972, 1974b). Our flow cytometry and calcium imaging data confirm and extend previous observations that ciliary ganglion neurons express many $\alpha 7$ receptors by E8 (Corriveau and Berg, 1993; Blumenthal et al., 1999; Brumwell et al., 2002). Whether the AON is spontaneously active at such early times is not clear, however, spontaneous electrical activity in the brainstem is detected using optical recording techniques at very early stages of embryonic development (Momose-Sato et al., 2003; Sato and Momose-Sato, 2003). In addition, ciliary neurons are enveloped in a preganglionic calyx at E8 that may serve to trap acetylcholine, bringing it to high levels if extracellular esterase activity is low. Finally, the kinetics of $\alpha 7$ -nAChR inactivation at E8 versus E13 have yet to be

examined. It is plausible that $\alpha 7$ -nAChRs at E8 inactivate more slowly than more mature receptors.

The molecular mechanism underlying $\alpha 7$ -nAChR effects on survival is likely to involve Ca^{2+} as an activator of cell death. Ca^{2+} is an intracellular messenger that operates over a wide temporal and spatial range to regulate many different cellular processes and Ca^{2+} overload has been suggested to be the final common pathway of all types of cell death (Berridge et al., 2003; Hajnoczky et al., 2003; Rizzuto et al., 2003). $\alpha 7$ -nAChRs have very high relative permeability to Ca^{2+} that is comparable to that of NMDA receptors. Furthermore, $\alpha 7$ -nAChRs are insensitive to Mg^{2+} blockade, which allows them to mediate Ca^{2+} influx at rest (Role and Berg, 1996a; Berg and Conroy, 2002). Therefore, we propose that activation of $\alpha 7$ -nAChRs can increase $[\text{Ca}^{2+}]_i$ to the levels that can be toxic to immature neurons. In support of this, a naturally occurring mutation in $\alpha 7$ -nAChR homolog induces cell death in *C. elegans* due to increased Ca^{2+} influx entering via slowly desensitizing receptors (Treinin and Chalfie, 1995). Transgenic mice homozygous for a similar gain of function mutation in $\alpha 7$ -nAChRs also exhibit widespread neuronal apoptosis (Orr-Urtreger et al., 2000). Furthermore, Ca^{2+} influx caused by activation of $\alpha 7$ -nAChRs induced apoptotic cell death in undifferentiated and immortalized hippocampal progenitor cells, but not in differentiated cells (Berger et al., 1998a). These progenitor cells were susceptible to Ca^{2+} overload due to their lack of buffering capability, while more mature neurons upregulated the expression of calbindin and no longer died as a result of $\alpha 7$ -nAChR activation. In line with this evidence, ciliary

ganglion neurons generate significantly larger increases in $[Ca^{2+}]_i$ in response to nicotine at E8 than at E9. In addition, after nicotine stimulation, E8 neurons exhibit a slower rate of intracellular Ca^{2+} decay than E13 neurons. Thus, E8 neurons with a large response to nicotine are likely to be more vulnerable to Ca^{2+} influx through $\alpha 7$ -nAChRs.

What prevents $\alpha 7$ -nAChRs from triggering cell death after the final number of neurons is established? In mature neurons, multiple factors control expression and signaling via $\alpha 7$ -nAChRs, thus protecting neurons from large, global increases in $[Ca^{2+}]_i$. For example, mature ciliary neurons cluster $\alpha 7$ -nAChRs on somatic spines (Shoop et al., 2001b; Shoop et al., 2002), narrowing the spatial signaling range of Ca^{2+} to somatic spines, where it can be handled regionally. Furthermore, $\alpha 7$ -nAChRs on mature neurons are excluded from postsynaptic densities and therefore are less likely to be activated by the release of acetylcholine from presynaptic terminals (Jacob and Berg, 1983; Horch and Sargent, 1995). Both types of neurons contain a large number of silent $\alpha 7$ -nAChRs, suggesting that the majority of $\alpha 7$ -nAChRs are normally prevented from signaling and are recruited only in special circumstances (McNerney et al., 2000a). In addition, ciliary neurotrophic factor (CNTF), which is expressed by ciliary ganglion target tissues, downregulates the expression of $\alpha 7$ -nAChRs (Halvorsen and Berg, 1989). Finally, endogenous neurotoxin-like molecules such as lynx1 are emerging as important modulators of $\alpha 7$ -nAChR function (Miwa et al., 1999; Ibanez-Tallon et al., 2002). In fact, ciliary ganglion neurons turn on expression of lynx related gene during the period of cell loss, which reduces the Ca^{2+} influx through $\alpha 7$ -nAChRs receptors (Rae Nishi, 2006 Soc. Neurosci. Abstr. 322.9.).

Other studies with pharmacological agents that block nicotinic signaling differ from our conclusion that inhibition of $\alpha 7$ -nAChRs prevents cell death in the ciliary ganglion. Pan-nicotinic antagonists such as chlorisondamine, pempidine, or d-tubocurare, reduce survival of ciliary ganglion neurons (Wright, 1981b; Meriney et al., 1987b; Maderdrut et al., 1988). Furthermore, removal of afferent input to the ciliary ganglion exacerbates cell death (Furber et al., 1987). These studies together with some cell culture models indicate that depolarization and increases in $[Ca^{2+}]_i$ normally enhance survival of ciliary ganglion neurons (Pugh and Margiotta, 2000). However, increases in intracellular free calcium can be either survival promoting or death inducing, depending on a neuron's Ca^{2+} set-point (Johnson et al., 1992; Ghosh and Greenberg, 1995). Therefore, excessive increases in intracellular Ca^{2+} via $\alpha 7$ -nAChRs could exceed threshold for an optimal Ca^{2+} set-point and induce cell death, while moderate increases in intracellular Ca^{2+} are survival promoting. To this end, we showed that individual E8 ciliary ganglion neurons express heterogeneous levels of $\alpha 7$ -nAChRs on their surface. As a result, some neurons display very large increases in $[Ca^{2+}]_i$ while others exhibit a much smaller elevation in $[Ca^{2+}]_i$ via $\alpha 7$ -nAChRs. Therefore, we propose that the neurons that die as a result of $\alpha 7$ -nAChR activation are the ones that express high levels of surface $\alpha 7$ -nAChRs and generate large $[Ca^{2+}]_i$ that exceed the set-point for cell death. Furthermore, activation of heteromeric $\alpha 3/\beta 4$ nAChRs, which is the second type of nAChRs in the ciliary ganglion, leads to smaller increases in $[Ca^{2+}]_i$ that could be survival promoting. Thus the balance between death-inducing signals via $\alpha 7$ -nAChRs and survival-promoting signals via $\alpha 3^*$ -nAChRs could determine which neurons die and which neurons survive.

Although our findings demonstrate that anterograde signaling via $\alpha 7$ -nAChRs influence the survival of ciliary ganglion neurons, they do not invalidate the neurotrophic hypothesis. In fact, inhibition of $\alpha 7$ -nAChRs with membrane-tethered α btx rescues only 41% of neurons from dying, which argues that $\alpha 7$ -nAChRs are not solely responsible for cell death of the ciliary ganglion neurons. Actually, ciliary ganglion neurons depend on ciliary neurotrophic factor (CNTF) for survival *in vitro* and *in vivo* and overexpression of CNTF in chicken embryos rescues 31% of ciliary ganglion neurons that would have normally died *in vivo* (Nishi and Berg, 1979, 1981; Finn et al., 1998). Therefore, we propose that the balance between death-inducing and survival-promoting factors determines the final numbers of neurons in the ganglion. Initially, death signals predominate, which is evidenced by large programmed cell death at E6, several days before the actual decrement in cell number and synaptogenesis with the target tissues (Lee et al., 2001). As neurons extend processes and synapse with their targets they become dependent on CNTF, which opposes the deleterious effects of $\alpha 7$ -nAChRs by downregulating their expression (Halvorsen and Berg, 1989) or upregulating modulators of nAChR function such as lynx-1. In conclusion, our results highlight the importance of nontraditional roles of nAChRs during neural development.

REFERENCES

Alkondon M, Pereira EF, Wonnacott S, Albuquerque EX (1992) Blockade of nicotinic currents in hippocampal neurons defines methyllycaconitine as a potent and specific receptor antagonist. *Mol Pharmacol* 41:802-808.

Berg DK, Conroy WG (2002) Nicotinic alpha 7 receptors: synaptic options and downstream signaling in neurons. *J Neurobiol* 53:512-523.

Berger F, Gage FH, Vijayaraghavan S (1998) Nicotinic receptor-induced apoptotic cell death of hippocampal progenitor cells. *J Neurosci* 18:6871-6881.

Berridge MJ, Bootman MD, Roderick HL (2003) Calcium signalling: dynamics, homeostasis and remodelling. *Nat Rev Mol Cell Biol* 4:517-529.

Bertrand D, Bertrand S, Ballivet M (1992) Pharmacological properties of the homomeric alpha 7 receptor. *Neurosci Lett* 146:87-90.

Blumenthal EM, Shoop RD, Berg DK (1999) Developmental changes in the nicotinic responses of ciliary ganglion neurons. *J Neurophysiol* 81:111-120.

Brumwell CL, Johnson JL, Jacob MH (2002) Extrasynaptic alpha 7-nicotinic acetylcholine receptor expression in developing neurons is regulated by inputs, targets, and activity. *J Neurosci* 22:8101-8109.

Bunker GL, Nishi R (2002) Developmental cell death in vivo: rescue of neurons independently of changes at target tissues. *J Comp Neurol* 452:80-92.

Chang KT, Berg DK (1999) Nicotinic acetylcholine receptors containing alpha7 subunits are required for reliable synaptic transmission in situ. *J Neurosci* 19:3701-3710.

Chang KT, Berg DK (2001) Voltage-gated channels block nicotinic regulation of CREB phosphorylation and gene expression in neurons. *Neuron* 32:855-865.

Coggan JS, Paysan J, Conroy WG, Berg DK (1997) Direct recording of nicotinic responses in presynaptic nerve terminals. *J Neurosci* 17:5798-5806.

Corriveau RA, Berg DK (1993) Coexpression of multiple acetylcholine receptor genes in neurons: quantification of transcripts during development. *J Neurosci* 13:2662-2671.

Coulombe JN, Schwall R, Parent AS, Eckenstein FP, Nishi R (1993) Induction of somatostatin immunoreactivity in cultured ciliary ganglion neurons by activin in choroid cell-conditioned medium. *Neuron* 10:899-906.

Davies AM (1996) The neurotrophic hypothesis: where does it stand? *Philos Trans R Soc Lond B Biol Sci* 351:389-394.

Eisen JS, Melancon E (2001) Interactions with identified muscle cells break motoneuron equivalence in embryonic zebrafish. *Nat Neurosci* 4:1065-1070.

Epstein ML, Davis JP, Gellman LE, Lamb JR, Dahl JL (1988) Cholinergic neurons of the chicken ciliary ganglion contain somatostatin. *Neuroscience* 25:1053-1060.

Federspiel MJ, Hughes SH (1997) Retroviral gene delivery. *Methods Cell Biol* 52:179-214.

Finn TP, Kim S, Nishi R (1998) Overexpression of ciliary neurotrophic factor in vivo rescues chick ciliary ganglion neurons from cell death. *J Neurobiol* 34:283-293.

Furber S, Oppenheim RW, Prevet D (1987) Naturally-occurring neuron death in the ciliary ganglion of the chick embryo following removal of preganglionic input: evidence for the role of afferents in ganglion cell survival. *J Neurosci* 7:1816-1832.

Ghosh A, Greenberg ME (1995) Calcium signaling in neurons: molecular mechanisms and cellular consequences. *Science* 268:239-247.

Hajnoczky G, Davies E, Madesh M (2003) Calcium signaling and apoptosis. *Biochem Biophys Res Commun* 304:445-454.

Halvorsen SW, Berg DK (1989) Specific down-regulation of the alpha-bungarotoxin binding component on chick autonomic neurons by ciliary neuronotrophic factor. *J Neurosci* 9:3673-3680.

Horch HL, Sargent PB (1995) Perisynaptic surface distribution of multiple classes of nicotinic acetylcholine receptors on neurons in the chicken ciliary ganglion. *J Neurosci* 15:7778-7795.

Ibanez-Tallon I, Miwa JM, Wang HL, Adams NC, Crabtree GW, Sine SM, Heintz N (2002) Novel modulation of neuronal nicotinic acetylcholine receptors by association with the endogenous prototoxin lynx1. *Neuron* 33:893-903.

Ibanez-Tallon I, Wen H, Miwa JM, Xing J, Tekinay AB, Ono F, Brehm P, Heintz N (2004) Tethering naturally occurring peptide toxins for cell-autonomous modulation of ion channels and receptors in vivo. *Neuron* 43:305-311.

Jacob MH, Berg DK (1983) The ultrastructural localization of alpha-bungarotoxin binding sites in relation to synapses on chick ciliary ganglion neurons. *J Neurosci* 3:260-271.

Johnson EM, Jr., Koike T, Franklin J (1992) A "calcium set-point hypothesis" of neuronal dependence on neurotrophic factor. *Exp Neurol* 115:163-166.

Landmesser L, Pilar G (1972) The onset and development of transmission in the chick ciliary ganglion. *J Physiol* 222:691-713.

Landmesser L, Pilar G (1974a) Synaptic transmission and cell death during normal ganglionic development. *J Physiol* 241:737-749.

Landmesser L, Pilar G (1974b) Synapse formation during embryogenesis on ganglion cells lacking the periphery. *J Physiol* 241:715-736.

Lee VM, Smiley GG, Nishi R (2001) Cell death and neuronal replacement during formation of the avian ciliary ganglion. *Dev Biol* 233:437-448.

Liu Z, Neff RA, Berg DK (2006) Sequential interplay of nicotinic and GABAergic signaling guides neuronal development. *Science* 314:1610-1613.

Maderdrut JL, Oppenheim RW, Prevet D (1988) Enhancement of naturally occurring cell death in the sympathetic and parasympathetic ganglia of the chicken embryo following blockade of ganglionic transmission. *Brain Res* 444:189-194.

Marusich MF, Weston JA (1992) Identification of early neurogenic cells in the neural crest lineage. *Dev Biol* 149:295-306.

Marwitt R, Pilar G, Weakly JN (1971) Characterization of two ganglion cell populations in avian ciliary ganglia. *Brain Res* 25:317-334.

McNerney ME, Pardi D, Pugh PC, Nai Q, Margiotta JF (2000) Expression and channel properties of alpha-bungarotoxin-sensitive acetylcholine receptors on chick ciliary and choroid neurons. *J Neurophysiol* 84:1314-1329.

Meriney SD, Pilar G, Ogawa M, Nunez R (1987) Differential neuronal survival in the avian ciliary ganglion after chronic acetylcholine receptor blockade. *J Neurosci* 7:3840-3849.

Miwa JM, Ibanez-Tallon I, Crabtree GW, Sanchez R, Sali A, Role LW, Heintz N (1999) *lynx1*, an endogenous toxin-like modulator of nicotinic acetylcholine receptors in the mammalian CNS. *Neuron* 23:105-114.

Momose-Sato Y, Mochida H, Sasaki S, Sato K (2003) Depolarization waves in the embryonic CNS triggered by multiple sensory inputs and spontaneous activity: optical imaging with a voltage-sensitive dye. *Neuroscience* 116:407-423.

Morgan BA, Fekete DM (1996) Manipulating gene expression with replication-competent retroviruses. *Methods Cell Biol* 51:185-218.

Nishi R (1996) Autonomic and sensory neuron cultures. *Methods Cell Biol* 51:249-263.

Nishi R, Berg DK (1979) Survival and development of ciliary ganglion neurones grown alone in cell culture. *Nature* 277:232-234.

Nishi R, Berg DK (1981) Two components from eye tissue that differentially stimulate the growth and development of ciliary ganglion neurons in cell culture. *J Neurosci* 1:505-513.

Oppenheim RW (1991) Cell death during development of the nervous system. *Annu Rev Neurosci* 14:453-501.

Orr-Urtreger A, Broide RS, Kasten MR, Dang H, Dani JA, Beaudet AL, Patrick JW (2000) Mice homozygous for the L250T mutation in the alpha7 nicotinic acetylcholine receptor show increased neuronal apoptosis and die within 1 day of birth. *J Neurochem* 74:2154-2166.

Pettmann B, Henderson CE (1998) Neuronal cell death. *Neuron* 20:633-647.

Potts WM, Olsen M, Boettiger D, Vogt VM (1987) Epitope mapping of monoclonal antibodies to gag protein p19 of avian sarcoma and leukaemia viruses. *J Gen Virol* 68 (Pt 12):3177-3182.

Pugh PC, Berg DK (1994) Neuronal acetylcholine receptors that bind alpha-bungarotoxin mediate neurite retraction in a calcium-dependent manner. *J Neurosci* 14:889-896.

Pugh PC, Margiotta JF (2000) Nicotinic acetylcholine receptor agonists promote survival and reduce apoptosis of chick ciliary ganglion neurons. *Mol Cell Neurosci* 15:113-122.

Rizzuto R, Pinton P, Ferrari D, Chami M, Szabadkai G, Magalhaes PJ, Di Virgilio F, Pozzan T (2003) Calcium and apoptosis: facts and hypotheses. *Oncogene* 22:8619-8627.

Rogers M, Sargent PB (2003) Rapid activation of presynaptic nicotinic acetylcholine receptors by nerve-released transmitter. *Eur J Neurosci* 18:2946-2956.

Rohrer H, Henke-Fahle S, el-Sharkawy T, Lux HD, Thoenen H (1985) Progenitor cells from embryonic chick dorsal root ganglia differentiate in vitro to neurons: biochemical and electrophysiological evidence. *Embo J* 4:1709-1714.

Role LW, Berg DK (1996) Nicotinic receptors in the development and modulation of CNS synapses. *Neuron* 16:1077-1085.

Sato K, Momose-Sato Y (2003) Optical detection of developmental origin of synaptic function in the embryonic chick vestibulocochlear nuclei. *J Neurophysiol* 89:3215-3224.

Shoop RD, Chang KT, Ellisman MH, Berg DK (2001) Synaptically driven calcium transients via nicotinic receptors on somatic spines. *J Neurosci* 21:771-781.

Shoop RD, Esquenazi E, Yamada N, Ellisman MH, Berg DK (2002) Ultrastructure of a somatic spine mat for nicotinic signaling in neurons. *J Neurosci* 22:748-756.

Snider WD (1994) Functions of the neurotrophins during nervous system development: what the knockouts are teaching us. *Cell* 77:627-638.

Treinin M, Chalfie M (1995) A mutated acetylcholine receptor subunit causes neuronal degeneration in *C. elegans*. *Neuron* 14:871-877.

Wang L, Galehouse D, Mellon P, Duesberg P, Mason WS, Vogt PK (1976) Mapping oligonucleotides of Rous sarcoma virus RNA that segregate with polymerase and group-specific antigen markers in recombinants. *Proc Natl Acad Sci U S A* 73:3952-3956.

Wright L (1981) Cell survival in chick embryo ciliary ganglion is reduced by chronic ganglionic blockade. *Brain Res* 227:283-286.

Zhang ZW, Coggan JS, Berg DK (1996) Synaptic currents generated by neuronal acetylcholine receptors sensitive to alpha-bungarotoxin. *Neuron* 17:1231-1240.

Zheng JQ, Felder M, Connor JA, Poo MM (1994) Turning of nerve growth cones induced by neurotransmitters. *Nature* 368:140-144.

Figure 1. Cell surface $\alpha 7$ -nAChRs on developing ciliary ganglion neurons.

Acutely dissociated neurons were incubated while alive with α btx-Alexa 488, then imaged (A-C) or subjected to flow cytometry (D-G). E13 neurons (B,C) were fixed and stained for somatostatin immunoreactivity to identify choroid neurons. (A) At E8, some neurons express a large number of $\alpha 7$ -nAChRs (arrow), while others have very low numbers (arrowhead). (B) At E13, $\alpha 7$ -nAChRs are clustered on ciliary neurons (arrows). (C) E13 choroid neurons have evenly distributed receptors on their cell surface. Similar results were obtained from three additional experiments. Images were captured as optical stacks on an Olympus epifluorescence microscope and deconvolved on a Deltavision workstation. Calibration bar = 15 μ m. (D-G) Acutely dissociated E6-E10 ciliary ganglion neurons were co-labeled with the neuronal specific Q211 antibody and α btx-Alexa 488 and at each age 40,000 cells were analyzed by flow cytometry. Axes for all four graphs are identical to those labeled in F. Cells in the upper right quadrant are neurons (Q211 positive) that express $\alpha 7$ nAChRs (α btx binding). The majority of neurons label at a tightly clustered level of α btx intensity; however, at E6 (D) and E7 (E), there is a subpopulation of cells with high α btx-Alexa 488 binding (arrowhead) and a subpopulation with very low α btx-Alexa 488 binding (arrow). (F) At E9, all neurons bind α btx, but few neurons still exhibit high α btx binding (arrowhead). (G) By E10, virtually all neurons have relatively homogeneous α btx-Alexa 488 binding.

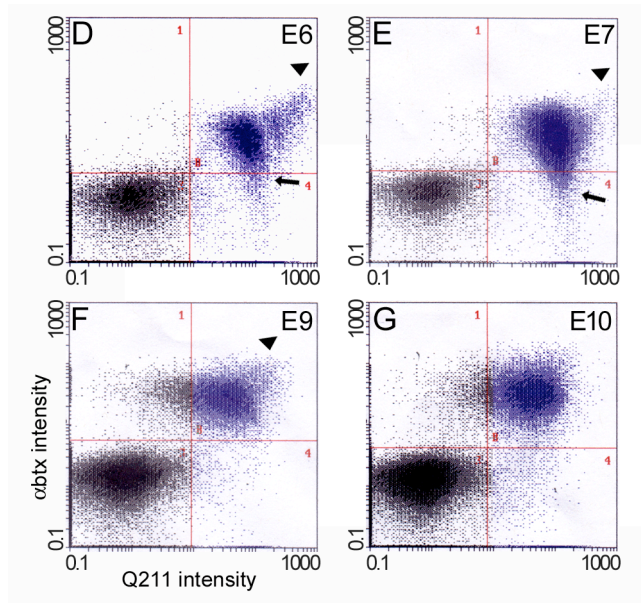
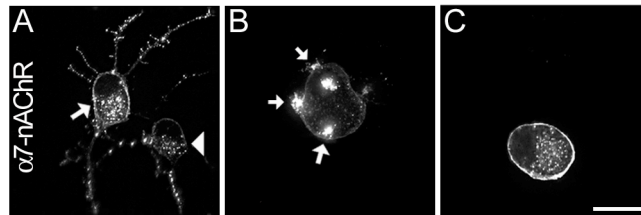

Figure 2. Calcium influx through $\alpha 7$ -nAChRs during ciliary ganglion development.

Acutely dissociated E8 neurons were loaded with the ratiometric calcium indicator dye Fura-2 and stimulated by perfusing with 10 μ M nicotine. (A) Cell responses to two applications of nicotine (Nic1 and Nic2) for 20 sec with 5 minute wash-out between them are shown. (B) The mean Nic1 and Nic2 Ca^{2+} responses are not significantly different, indicating that nAChRs recover from desensitization during the 5 minute wash-out ($p > 0.05$ Student t-test, $n = 14$ neurons). (C) Nicotine induced Ca^{2+} response is significantly reduced by treatment with MLA ($n = 34$ neurons, $p < 0.0001$, one-way ANOVA) and completely eliminated by treatment with MLA and DH β E ($n = 30$ neurons; $p < 0.0001$, one-way ANOVA). (D) At E8, $\alpha 7$ -nAChRs-specific Ca^{2+} responses are distributed over a wide range (mean 0.09 ± 0.007 , $n = 41$), while E9 Ca^{2+} responses are skewed to the left with majority of Ca^{2+} responses clustered around mean (0.06 ± 0.004 , $n = 80$). Compared to E9 neurons, 20 sec application of 10 μ M nicotine induces larger increases in $[\text{Ca}^{2+}]_i$ in E8 neurons ($p < 0.0002$, Student t-test). (E,F) The rate of Ca^{2+} decay was measured in E8 and E13 acutely dissociated neurons. Traces were normalized to the percent of peak Ca^{2+} amplitude in order to detect changes in the time course of Ca^{2+} decay. (E) At E8, Ca^{2+} decays back to baseline at much slower rate than at E13 (E8: $\tau = 48.9 \pm 0.98$ s, $n = 33$ from 3 different ganglia; E13: $\tau_1 = 17.5 \pm 0.42$ s, $\tau_2 = 175.6 \pm 91.4$ s, E13 $n = 6$ from 5 different ganglia). (F) Treatment with MLA eliminates the differences in the rate of Ca^{2+} decay between E8 and E13 neurons. Values represent mean \pm SEM.

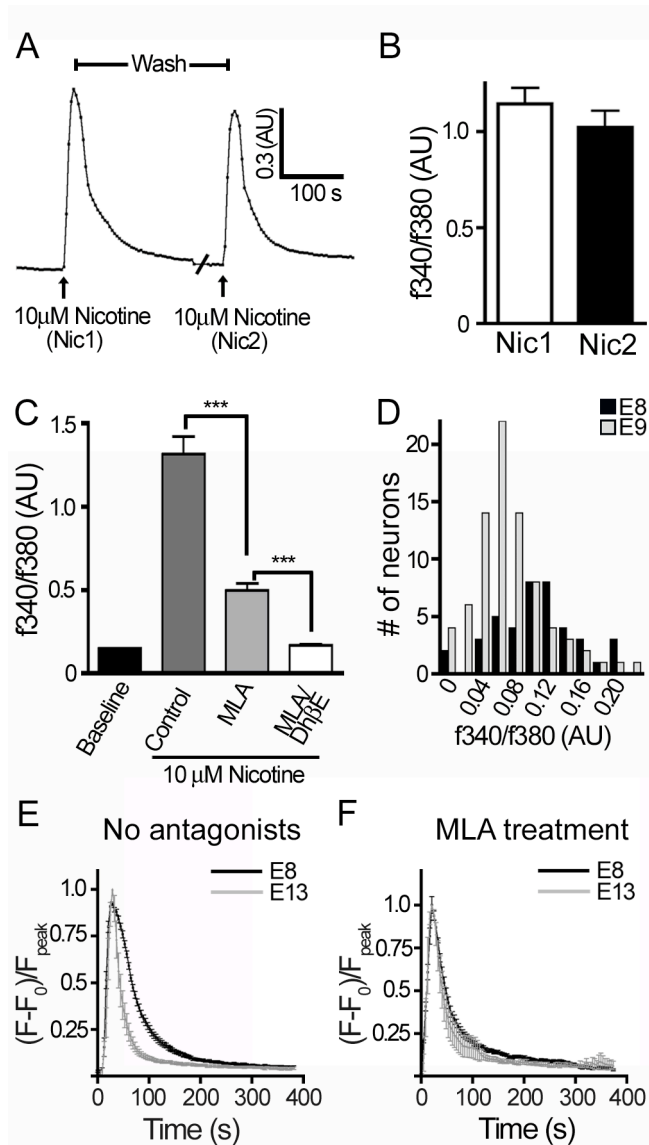
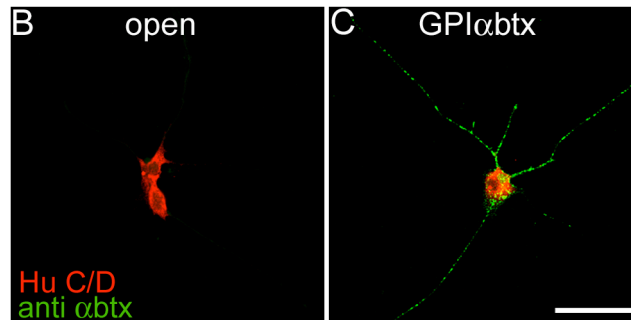

Figure 3. GPI α btx expression in ciliary ganglion neurons after injection with RCASBP(A) retrovirus.

(A) Diagram of GPI α btx cassette, containing the mature α btx sequence linked to the lynx1 consensus sequence for addition of a GPI anchor. (B,C) Dissociated E8 ciliary ganglion neurons infected with (B) control (open) RCASBP(A) or (C) RCASBP(A)-GPI α btx were incubated with anti- α btx while alive at 4°C in order to label cell surface α btx (green), then fixed and co-labeled with neuronal specific HuC/D antibody (red) to demonstrate efficacy of infection. Only neurons infected with the RCASBP(A)- GPI α btx are labeled with the antibody. Calibration bar = 10 μ m.

(D) GPI α btx-infected neurons exhibit significant reduction in calcium influx via α 7-nAChRs compared to the open-infected neurons ($P < 0.0001$, Student's t-test). GPI α btx reduces the peak Ca^{2+} amplitude to the same extent as exogenously applied α btx and exogenous application of α btx does not further reduce peak calcium amplitude in GPI α btx-infected neurons. Values represent mean \pm SEM of results from ≥ 20 neurons for each treatment from three separate experiments.

A



D

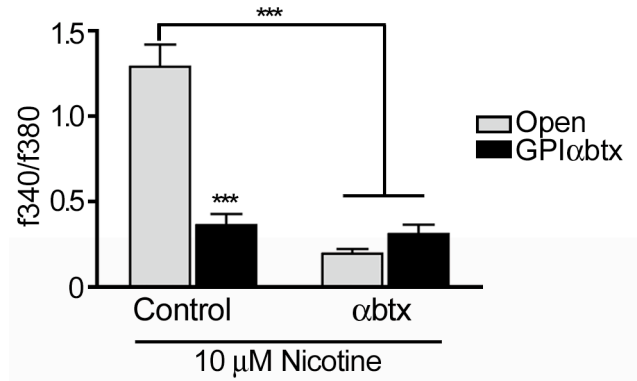

Figure 4. The majority of GPI α btx is not released from cell membranes.

(A-D) Uninfected or GPI α btx infected E8 neurons were incubated alone or co-incubated for 24 hours and then labeled while alive with α btx-Alexa 488 to identify cell surface α 7-nAChRs. Uninfected neurons label brightly with α btx-Alexa 488 whether they are incubated alone (B), or co-incubated with GPI α btx-infected neurons (D), demonstrating that few of the cell surface α 7-nAChRs are occupied by GPI α btx that has been released from the membrane. (C) GPI α btx-infected neurons do not label with α btx-Alexa 488, showing that cell surface α 7-nAChRs are either occupied by membrane-tethered α btx or because they fail to traffic to the cell surface when GPI α btx is expressed. Calibration bar = 15 μ m.

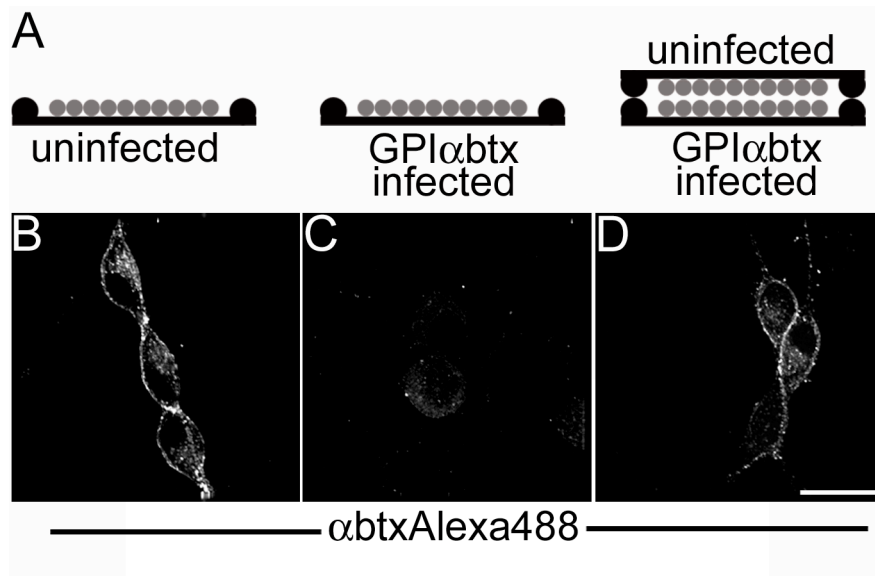

Figure 5. Cell-autonomous inhibition with GPI α btx rescues ciliary ganglion neurons from cell death.

Embryos were infected with open RCASBP(A) or RCASBP(A)-GPI α btx at 36 hrs of development (St. 8-9; A-C) or 48 hrs of development (St. 10-13; D-F). Immunoreactivity for p27gag (green) is observed in neurons (red) of ciliary ganglia from embryos infected at St. 8-9 (A,C; arrows indicate few uninfected neurons), while only surrounding non-neural tissue is immunoreactive for p27gag in embryos infected at St. 10-13 (D,F).

Calibration bars = 200 μ m (inset = 50 μ m). (G) Serially sectioned E14 ganglia were labeled with neuronal-specific Islet-1 antibody (nuclear, arrows) and somatostatin antibody (cytoplasmic, arrowheads) to identify choroid neurons. Calibration bar = 50 μ m.

(H) The total number of neurons (Islet-1 positive) and the number of choroid neurons (somatostatin-positive) in sections stained as in G were counted by design-based stereology and the number of ciliary neurons was inferred by subtracting the number of choroid neurons from the total. Expression of GPI α btx prevents cell death of ciliary ($p < 0.01$, one-way ANOVA) and choroid ($p < 0.001$, one-way ANOVA) neurons.

Expression of GPI α btx only in surrounding non-neural tissues does not prevent cell death. Values represent mean \pm SEM.

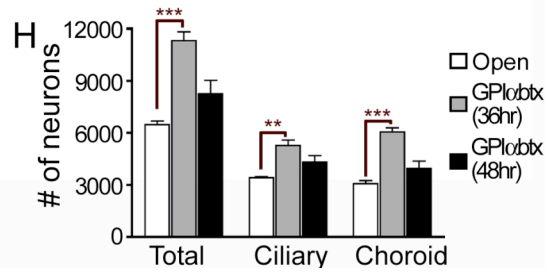
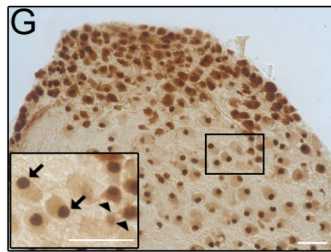
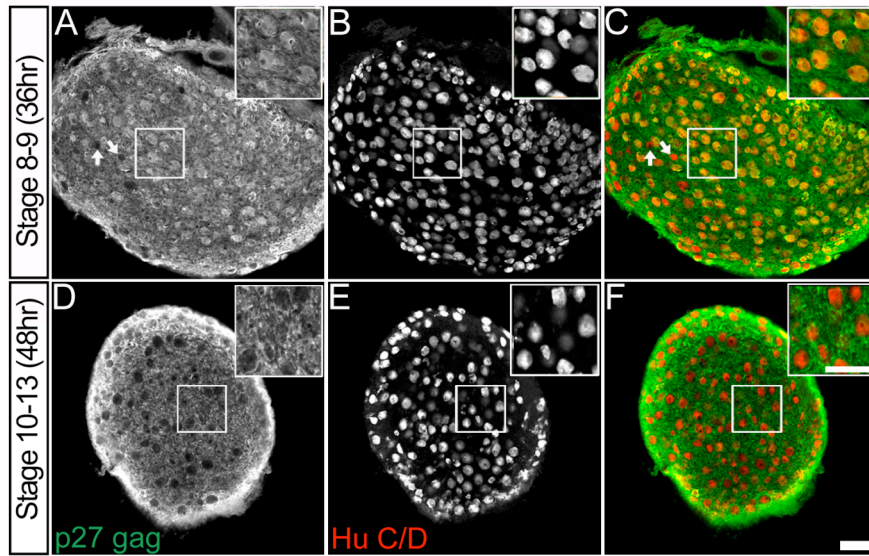
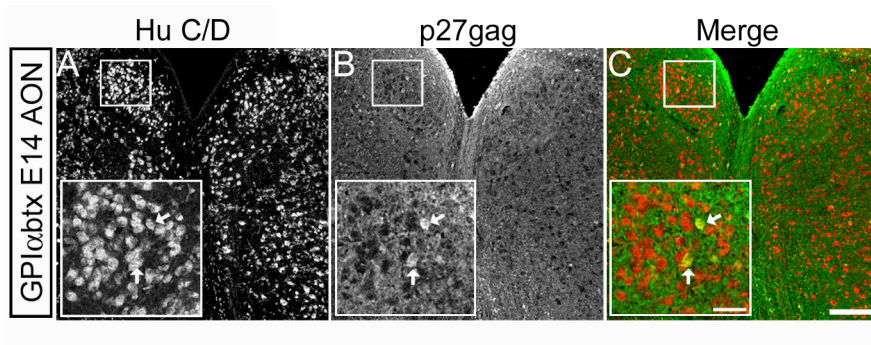

Figure 6. Presynaptic $\alpha 7$ -nAChRs from AON are unlikely to mediate death of ciliary ganglion neurons.

(A) Neurons in the preganglionic AON from embryos infected at St. 8-9 were identified with HuC/D antibody. (B) Only surrounding glia, but not HuC/D positive cells, label with p27gag antibody, indicating that AON neurons are not infected. (C) Overlay of the HuC/D immunoreactivity (red) with the p27gag immunoreactivity (green). Only a few neurons show p27gag immunoreactivity (C; arrows). Calibration bar = 200 μm (inset = 50 μm).



Supplementary Figure 1. Specificity of rabbit anti- α btx.

Purified α btx protein was probed with rabbit anti- α btx and analyzed by (A) ELISA and (B) western blot. (A) 50 μ g of α btx protein was used to coat the wells. Rabbit anti- α btx was serially diluted as shown. Goat anti-rabbit coupled to alkaline phosphatase (1:2500) together with p-nitrophenyl phosphate diluted in alkaline phosphatase buffer was used to develop the signal. Rabbit anti- α btx detected purified α btx protein and this signal was effectively blocked by preabsorbing the antibody with 100 μ g of α btx protein. (B) Purified α btx protein was separated on 14% polyacrylamide gel and transferred to PVDF membrane. Rabbit anti- α btx (1:10,000) was used to probe the membrane. The signal was detected with goat anti-rabbit AlexaFlour 680 (1:20,000) by scanning the membrane on LI-COR infrared scanner. The antiserum is able to detect 65 ng of α btx at a 1:10,000 dilution.

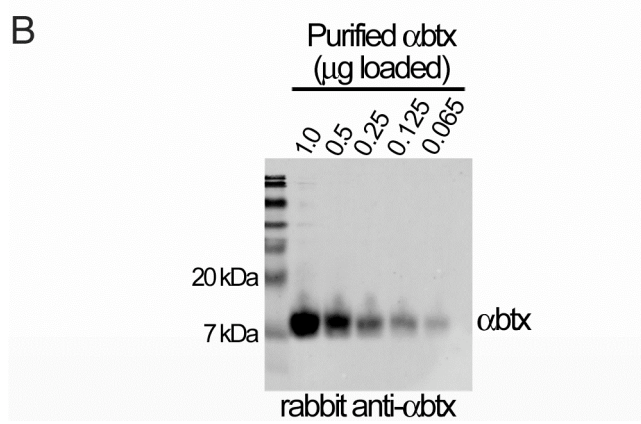
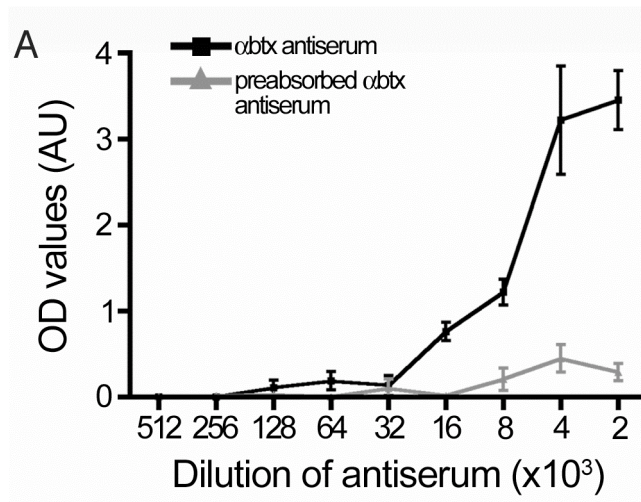

CHAPTER 3

PROSTATE STEM CELL ANTIGEN IS AN ENDOGENOUS PROTOTOXIN THAT ANTAGONIZES ALPHA 7 CONTAINING NICOTINIC RECEPTORS AND PREVENTS PROGRAMMED CELL DEATH OF PARASYMPATHETIC NEURONS

**Martin Hruska¹, Julie Keefe¹, David Wert¹, Ayse Begum Tekinay², Inez Ibanez-
Tallon³ and Rae Nishi^{1*}**

¹Department of Anatomy and Neurobiology
University of Vermont College of Medicine
Burlington, VT 05405

²Rockefeller University, Howard Hughes Med Inst
Laboratory of Molecular Biology
1230 York Ave, Box 260
New York NY 10021

³Molecular Neurobiology Group
Max-Delbrück-Center
Robert-Rössle-Str. 10
13125 Berlin
Germany

*Corresponding Author
Dept. Anatomy and Neurobiology
HSRF 406
149 Beaumont Ave.
Burlington, VT 05405
Voice: 802-656-4504
Fax: 802-656-8704
Email: rnishi@uvm.edu

SUMMARY

Vertebrate prototoxins modulate nicotinic acetylcholine receptor (nAChR) function and have been implicated as balancers of neuronal activity and survival in vivo. To identify members of this family involved in regulating programmed cell death during development, we screened a chick expressed sequence tag database using lynx1 and lynx2 and identified 6 sequences, of which one, an ortholog of prostate stem cell antigen (PSCA), is significantly upregulated in the ciliary ganglion during the period of cell loss. PSCA expression is neural specific and correlates with the expression of nAChRs. If PSCA is overexpressed in ciliary ganglion neurons, $\alpha 7$ -nAChR activation by nicotine is selectively blocked. Furthermore, premature expression of PSCA in vivo rescues the choroid, but not the ciliary neuron subpopulation. These results demonstrate a developmental function for PSCA and suggest that other members of the prototoxin family may serve similar functions.

INTRODUCTION

Nicotinic acetylcholine receptors (nAChRs) are ligand-gated ion channels that play an essential role in a wide variety of processes in the nervous system including synaptic plasticity, perception of pain, and attention (Dani and Bertrand, 2007; Rezvani and Levin, 2001). Activation of postsynaptic nAChRs causes rapid depolarization and mediates fast synaptic transmission, while presynaptic nAChRs control the release of neurotransmitter (Dani, 2001). To date, 17 nAChR subunits have been cloned, including 10 alpha subunits, 4 beta subunits, and the muscle specific delta, gamma and epsilon subunits. Functional neuronal nAChRs are comprised of alpha and beta containing heteromers or alpha 7 containing homomers, and they have widespread, yet specific patterns of expression in the central and peripheral nervous system (Role and Berg, 1996). All nAChR channels are permeable to calcium in addition to sodium and potassium, with alpha 7 homomers having a calcium permeability comparable to the unblocked NMDA channel (Berg and Conroy, 2002). Thus, nAChRs have been implicated in calcium-dependent functions such as regulating gene expression in addition to mediating chemical neurotransmission (Chang and Berg, 2001). In fact, nAChRs have been found in a number of non-neuronal cell types including lymphocytes, keratinocytes, epithelium, and gut endothelium (Sharma and Vijayaraghavan, 2002).

Nicotinic signaling has also been implicated in controlling programmed cell death during development. By far the most effective means of rescuing spinal cord motor neurons

from dying is to treat embryos with nicotinic antagonists of neuromuscular transmission such as d-tubocurarine (dTC) or alpha-bungarotoxin (α btx) (Pittman and Oppenheim, 1979). Similarly, up to 90% of the neurons in the avian ciliary ganglion are rescued by antagonists of α 7 nAChRs such as α btx and MLA (Bunker and Nishi, 2002); however, non-selective nAChR antagonists that completely block ganglionic transmission exacerbate cell death (Maderdrut et al., 1988; Meriney et al., 1987; Wright, 1981). In cell culture, nicotine promotes survival of neurons, but it does so at concentrations at which α 7 nAChRs are desensitized (Pugh and Margiotta, 2000). Thus, nicotinic signaling through specific subsets of nAChRs may contribute differentially to neuronal survival, with activation of α 7 nAChRs exacerbating cell death, while heteromeric nAChRs promote neuronal survival.

One means by which nicotinic signaling can be regulated is by the expression of endogenous prototoxins that are structurally homologous to snake venom neurotoxins that antagonize specific subclasses of nAChRs. These molecules are members of the super family of Ly6 molecules that are GPI-linked, cysteine-rich molecules that are expressed in the nervous system. A number of members of this family have been identified, including Ly6H, lynx1, lynx2 and SLURP-1 (Chimienti et al., 2003; Dessaud et al., 2006; Horie et al., 1998; Miwa et al., 1999). These molecules fold into the typical three-fingered loop structure of α btx (Miwa et al., 1999). In Heterologous expression systems, mouse lynx1 binds to and alters the kinetics of α 7 and α 4 β 2 nAChRs (Ibanez-Tallon et al., 2002). Furthermore, cortical neurons of mice lacking lynx1 have an

enhanced sensitivity to nicotine that potentiates excitotoxicity, while aging lynx1 null mice exhibit an exacerbated degeneration of the central nervous system that is enhanced by nicotine and attenuated by loss of nAChRs (Miwa et al., 2006).

In the present study we determined whether endogenous prototoxins are expressed during the development of the avian ciliary ganglion. The ganglion contains two types of neurons, ciliary and choroid, and both receive cholinergic innervation that is detectable at E5.5 and complete by E8 (Landmesser and Pilar, 1972). Programmed cell death coincides with the arrival of afferents, with a loss of over half of the neurons occurring between E8 and E14 (Furber et al., 1987; Landmesser and Pilar, 1974; Lee et al., 2001). By E8, both ciliary and choroid neurons express two major subclasses of nAChRs: $\alpha 7$ nAChRs and heteromeric $\alpha 3^*$ nAChRs containing $\alpha 3$, $\alpha 5$, $\beta 4$ subunits (Blumenthal et al., 1999; McNerney et al., 2000) and sometimes $\beta 2$ (Conroy and Berg, 1995). The number of receptors increases steadily with development; however, by E14, there are many fewer functional $\alpha 3^*$ and $\alpha 7$ receptors than are found on the surface, suggesting that “silent” nAChRs predominate (McNerney et al., 2000). A mechanism that could silence cell surface $\alpha 7$ nAChRs is the cell autonomous binding of an accessory molecule that prevents binding of acetylcholine or alters the kinetics of ligand induced channel opening such as lynx1. Using mouse lynx1 and lynx2 we screened for homologous molecules in the chick and identified 6 molecules. Of these, one is induced in the ciliary ganglion during the period of cell loss and is the chick ortholog of human prostate stem cell antigen (PSCA). PSCA prevents rises in intracellular calcium due to nicotine and its

misexpression prior to loss of neurons in the ciliary ganglion rescues choroid neurons from cell death. This suggests a function for endogenous prototoxins during development of the nervous system.

RESULTS

Identification of chicken lynx sequences

Since mouse lynx1 interacts with α 7-nAChRs from chicken (Ibanez-Tallon et al., 2002), we used the amino acid sequences of mouse lynx1 and lynx2 to search a chicken expressed sequence tag (EST) database for proteins that had the Ly6 domain as the only functional domain and whose genes matched the exon-intron structures of lynx1 and other toxins that have the Ly6 domain. Six sequences that matched these criteria were identified (Fig. 1A). All 6 sequences are cysteine-rich and 10 of the cysteine residues are aligned across all molecules. The sequences also encode an N-terminal signal sequence and a C-terminal consensus sequence for creating a glycosyl-phosphatidylinositol linkage to the membrane. When analyzed by SMART (a Simple Modular Architecture Research Tool; <http://smart.embl-heidelberg.de/>), all molecules are also predicted to fold into a three-fingered coiled structure similar to that of mouse lynx1 and the cobra venom neurotoxins (Gumley et al., 1995). This striking structural homology suggests that these chicken molecules can interact with nicotinic acetylcholine receptors as shown for mouse lynx1 (Ibanez-Tallon et al., 2002).

To determine if any of the 6 EST transcripts were expressed in a developmentally regulated pattern in the ciliary ganglion, we used sequence specific primers to amplify cDNA from ciliary ganglia collected from embryonic days (E) 8, while cell death is occurring, and E15, which is a day after cell death has ceased (Landmesser and Pilar,

1974). Three sequences, ch3Ly, ch5Ly and ch6Ly were expressed in E15 ganglia; however, ch3Ly and ch5Ly were also expressed at E8 (Fig. 1B). In contrast, no expression of ch6Ly is detectable at E8 (Fig. 1B). Identity of the amplified gene product as ch6Ly was confirmed by sequencing. The remaining transcripts are not expressed in the embryonic ciliary ganglion (data not shown). Ch6Ly encodes a pro-protein of 122 amino acids, which corresponds to a molecular weight of 11,160 Da. The mature GPI-linked protein is 8,051 Da. When ch6Ly is used to search Entrez, it matches mouse prostate stem cell antigen, with which it shares 40% amino acid identity and 80% homology (Fig. 2A). Like ch6Ly, open reading frame (ORF) of mouse PSCA shares the homology with other Ly6 superfamily members and contains cysteine rich Ly6 domain (Fig. 2B). Thus, ch6Ly is likely to be the chicken ortholog of prostate stem cell antigen (PSCA), Ly6 family member whose expression becomes upregulated in prostate tumors (Reiter et al., 1998).

Expression pattern of chicken PSCA

To determine the specificity of chicken PSCA expression, we quantified transcripts in a variety of tissues in the E15 chicken embryo using real-time PCR and normalized these levels to chick ribosomal binding protein s17 (CHRPS), a constitutively expressed housekeeping gene that is abundant in all tissues (Table 1). Heart expresses the lowest levels of PSCA and, therefore, relative expression of PSCA in all other tissues was compared to that of heart. Skeletal muscle, liver, ovary and testes (data not shown) have

1.5-fold higher levels of PSCA mRNA than heart. In the nervous system, the cerebellum, a structure with few cholinergic synapses also has very low levels; however, the telencephalon has 7-fold greater levels of PSCA mRNA than cerebellum. In the peripheral nervous system, ciliary and sympathetic ganglia contain significantly higher levels of PSCA mRNA than heart ($p < 0.05$, one-way ANOVA). The levels of PSCA transcripts in the peripheral ganglia are another 2.5 to 7-fold higher than the telencephalon and ciliary ganglion contains significantly higher levels of PSCA than cerebellum ($p < 0.05$, one-way ANOVA). Dorsal root ganglia also express higher levels of PSCA mRNA if compared to heart and liver, but 5 to 10-fold less than sympathetic or ciliary ganglia.

Because PSCA is enriched in the nervous tissues of chicken embryos, we determined whether mammalian tissues exhibit a similar expression pattern of PSCA mRNA. We isolated the neural and non-neural tissues from adult mice and quantified relative abundance of mouse PSCA normalized to β -actin. As in nearly mature chicken embryos, the nervous tissues isolated from adult mice contain significantly higher levels of PSCA than non-neural tissues (Table 2). Furthermore, the superior cervical ganglia express nearly twice as much PSCA as cerebellum and telencephalon and this increase is also significant ($p < 0.001$, one-way ANOVA). Thus, PSCA is expressed at very high levels in neural tissues, and its level of expression correlates with the transcript expression of $\alpha 7$ and $\alpha 3$ subunits of nAChRs in these ganglia (Fig. 3A and Table 1), suggesting a role of PSCA in modulating nAChR signaling.

In ciliary ganglia, expression of PSCA mRNA is developmentally regulated between E8 and E15, suggesting that PSCA plays an important role during cell death, possibly by interacting with $\alpha 7$ -nAChRs, which have previously been implicated in inducing cell death (Bunker and Nishi, 2002, Hruska and Nishi, 2007, in press). If PSCA is involved in regulating cell death through $\alpha 7$ subunit containing nAChRs, then its expression should be low when cell death commences, and it should be upregulated as neurons in the ganglion extend axons to the periphery and initiate synaptogenesis. Accordingly, we used real time PCR to quantify PSCA transcripts and normalized expression to Islet-1, a transcription factor that is expressed solely in neurons throughout embryonic development in the ciliary ganglion (Lee et al., 2001). By normalizing to Islet-1, we could thus correct for the 50% decrease in neuronal number that occurs between E8 and E15. PSCA transcripts from ciliary ganglia are low but detectable at E8 with a 100-fold increase from E8 to E13 (Fig. 3B, $p < 0.05$, one-way ANOVA). The PSCA transcript levels remain steady through E14, and by E15 PSCA is significantly upregulated in the ciliary ganglion with levels that are approximately 10^8 -fold higher than those found at E8 (Fig. 3B; $p < 0.001$, one-way ANOVA). Thus, the expression pattern of PSCA mRNA fits with its role as a modifier of cell death that is induced by interactions between the target and innervating neurons.

PSCA blocks activation of $\alpha 7$ nAChRs and rescues choroid neurons from cell death

To test whether PSCA could modify nicotine-induced responses in ciliary ganglion neurons, we used the retroviral vector RCASBP(A) to express PSCA prematurely at E8. If infective RCASBP(A)-PSCA particles are injected at St. 8-9 (36 hrs of incubation), virtually all of the ciliary ganglion neurons are infected (Fig. 4A-C), while little or no infection is detected in the accessory oculomotor nucleus, which innervates the ciliary ganglion (Fig. 4G-I). We removed PSCA-misexpressing ciliary ganglia and vector-only infected controls at E8, plated the neurons from dissociated ganglia on coverslips, and loaded them with the calcium sensitive dye, fura-2, in order to quantify intracellular calcium in response to rapidly perfused nicotine. TTX and cobalt were added to the perfusion solution to inhibit voltage-gated sodium and calcium channels, respectively.

Nicotine induces a large increase in intracellular calcium, of which 50-60% can be blocked by 50 nM MLA or 50 nM α btx (Fig. 5A and data not shown). When neurons infected with RCASBP(A)-PSCA are compared to those infected with open-RCASBP(A), the nicotine induced rise in intracellular calcium is reduced by 43% ($p < 0.0001$, Student t-test; open: 0.3 ± 0.02 , $n=69$; PSCA: 0.17 ± 0.01 , $n=86$), and this response cannot be further lowered by the inclusion of $\alpha 7$ -nAChR specific antagonist, α btx (Fig 5C). In contrast, inclusion of α btx to open-RCASBP(A) infected neuronal cultures significantly reduces the amplitude of Ca^{2+} transients to the levels that are comparable to the PSCA infected neurons (Fig. 5C; $p < 0.0001$, Student t-test open: $0.3 \pm$

0.02, n=69, open+btx: 0.14 ± 0.02 , n=31). Furthermore, increases in $[Ca^{2+}]_i$ when neurons are depolarized with 25 mM KCl are not significantly different between RCASBP(A)-open and RCASBP(A)-PSCA infected neurons, indicating that the differences in nicotinic responses between these two groups are not due to the unequal loading with fura-2 (Fig. 5B). Thus, retrovirally delivered PSCA is expressed at E8 in ciliary ganglion neurons and it specifically suppresses activation of $\alpha 7$ -nAChRs.

To determine if the premature expression of PSCA by E8 caused a change in the final number of neurons recovered in the ciliary ganglion, we infected neurons at St. 8-9 of development with a retroviral vector containing full length PSCA and quantified the total number of neurons as well as the number of choroid neurons at E14 by using design-based stereology (Bunker and Nishi, 2002; Lee et al., 2001). Neurons were identified by the expression of the transcription factor Islet-1; subpopulations were identified by somatostatin immunoreactivity, which is found in choroid neurons, but not in ciliary neurons (Coulombe et al., 1993; Epstein et al., 1988). On the average, PSCA expressing ganglia contained 35% more choroid neurons as ganglia infected with open-RCASBP(A) ($p < 0.0001$, one-way ANOVA; open: 4679 ± 353.4 , n=16; PSCA at 36hrs: 7125 ± 355.1 , n=13) and this was reflected in a significant change in the total number of neurons in the ganglion ($p < 0.001$ one-way ANOVA; open: 8626 ± 418.8 , n=16; PSCA at 36hrs: 11173 ± 467 , n=13), indicating that the change in the number of neurons expressing somatostatin-like immunoreactivity was not merely due to a shift in neuropeptide expression (Fig. 6). Interestingly, the number of ciliary neurons remained unchanged

(Fig. 6), suggesting that choroid neurons are more sensitive to the expression of PSCA. If injections of RCASBP(A)-PSCA retrovirus into the neural tube are delayed to St .10-13 (48 hrs of incubation), then ciliary ganglion neurons are not infected but neighboring glia are (Fig. 5 D-F). These “late-injected” ganglia serve as controls for non-cell autonomous effects of the membrane-tethered PSCA. In contrast to neuronally expressed PSCA, PSCA expressed in neighboring glia fails to rescue neurons from dying (Fig. 6; PSCA at 48 hrs: 9352 ± 646.1 , n=9).

DISCUSSION

The principal finding of this study is that PSCA, a molecule originally identified as an antigen upregulated in prostate cancer, is a prototoxin that prevents signaling through $\alpha 7$ subunit containing nAChRs. PSCA is expressed at considerably higher levels in the nervous system and the levels at which it is expressed correlate with the relative expression of $\alpha 7$ containing nAChRs. In the avian ciliary ganglion, PSCA expression is induced and upregulated between E8 and E15, a time during which half of the neurons are lost by cell death and peripheral synaptogenesis is completed. Furthermore, forcing premature expression of PSCA prevents choroid neurons from dying. These results suggest a modulatory function for prototoxins in nicotinic signaling.

PSCA belongs to the Ly6 superfamily, which are GPI-linked molecules expressed in tissue specific patterns during development and in the adult. To date, the function of such molecules has been mysterious because their small size and lack of a transmembrane domain preclude a direct role in mediating cell signaling (Gumley et al., 1995). Within this family, molecules that fold into a structure homologous to those formed by cobratoxins (Betzel et al., 1991; Tsetlin, 1999), which bind with high affinity to specific subclasses of nAChRs, have been described as prototoxins and include mouse lynx1 (Miwa et al., 1999), mouse lynx2 (Dessaud et al., 2006), Ly6H (Horie et al., 1998) and SLURP-1 (Chimienti et al., 2003). These endogenous prototoxins are expressed in the CNS and the PNS, and likely act as molecules that interact cell autonomously to

modulate nicotinic receptor function *in vivo*. Indeed, *lynx1* colocalizes with $\alpha4/\beta2$ as well as $\alpha7$ subunit containing nAChRs in mouse CNS and this association alters nAChR kinetics, extent of receptor desensitization and agonist affinity (Ibanez-Tallon et al., 2002; Miwa et al., 1999). Furthermore, neurons from *lynx1* null mice exhibit large increases in $[Ca^{2+}]_i$ in response to nicotine and, as a result, display age-dependent degeneration that is exacerbated by nicotine and ameliorated by null mutations in nAChRs (Miwa et al., 2006). Our analyses indicate that PSCA exhibits many of the features of a prototoxin: 1) it is cysteine-rich, with a spacing of cysteine residues that is conserved with other members of the family; 2) it is highly expressed in tissues of nervous system that contain high levels of $\alpha7$ -nAChRs and these data are corroborated by *in situ* hybridization from mouse brain, where PSCA is detected in Purkinje and granule cell layers of cerebellum, cerebral cortex and hippocampus (<http://www.brain-map.org/mouse/brain/Psca.html>); 3) it is predicted to form a “three-fingered” tertiary structure similar to that of nicotinic antagonists derived from cobratoxin; 4) it interferes with nicotine-induced increases in $[Ca^{2+}]_i$ through $\alpha7$ -nAChRs, but not heteromeric nAChRs. These results suggest that many other members of the Ly6 superfamily may also serve as prototoxins with selectivity for specific classes of nAChRs.

Nicotinic signaling has long been known to play an important role in regulating programmed cell death during development. Blocking neuromuscular transmission with nicotinic antagonists such as d-tubocurarine or α -bungarotoxin is one of the most effective ways to rescue spinal cord motor neurons from dying (Pittman and Oppenheim,

1978; Pittman and Oppenheim, 1979). In the autonomic and the central nervous system, activation of neuronal nAChRs can directly induce apoptosis. For example, chronic blockade of $\alpha 7$ -nAChRs with systemically applied α btx or MLA prevents cell death of nearly all ciliary ganglion neurons (Bunker and Nishi, 2002; Meriney et al., 1987). In addition, reduction in Ca^{2+} influx through $\alpha 7$ -nAChRs in a cell-autonomous manner prevents ciliary and choroid neurons from dying, suggesting that large $\alpha 7$ -nAChR mediated increases in $[\text{Ca}^{2+}]_i$ promote cell death of ciliary ganglion neurons during development (Hruska and Nishi, 2007 in press). Immature neurons are especially vulnerable to Ca^{2+} influx via $\alpha 7$ -nAChRs; activation of these channels induces apoptosis of hippocampal progenitor cells but not differentiated hippocampal neurons (Berger et al., 1998). Since the activation of $\alpha 7$ -nAChRs can be pro-apoptotic in certain neuronal populations, the signaling through these channels must be precisely regulated.

Our data are consistent with PSCA acting as a modulator of nicotinic signaling in the ciliary ganglion that limits cell death caused by activation of $\alpha 7$ -nAChRs in neurons vulnerable to calcium overload. At E8, when PSCA is undetectable, many ciliary ganglion neurons are undergoing apoptotic cell death (Lee, 2001). Subsequent upregulation of PSCA correlates with a significant decrease in cell death, reflected in the stabilization of neuronal cell number. Overexpression of PSCA at E8, when it is not normally expressed, blocks nicotine-induced increases in intracellular calcium through $\alpha 7$ -nAChRs and prevents cell death of choroid but not ciliary neurons. Consistent with this, it has been estimated that approximately a third of the $\alpha 7$ containing nAChRs on

mature choroid neurons are “silent” (McNerney et al., 2000). That is, there are more receptors on the surface than can be accounted for by measuring whole cell ACh-induced current through $\alpha 7$ -nAChRs. The number of silent $\alpha 7$ -nAChRs increases between E8 and E15 (Blumenthal et al., 1999; McNerney et al., 2000), which correlates with the increase in PSCA mRNA that we observe.

In contrast to a membrane-tethered α btx, which also prevents nicotine-induced increases in $[Ca^{2+}]_i$ via $\alpha 7$ -nAChRs (Hruska and Nishi, 2007, in press), PSCA rescues only choroid neurons rather than both ciliary and choroid subpopulations. This suggests that intrinsic differences between ciliary and choroid neurons could be responsible for the differential effect of PSCA on ciliary ganglion neurons. In fact, ciliary neurons cluster $\alpha 7$ -nAChRs on somatic spines that develop between E10 and E14 (Shoop et al., 2001; Shoop et al., 1999), thus, they have a mechanism that protects them from the global increases in $[Ca^{2+}]_i$ and choroid neurons display larger $\alpha 7$ -nAChR-mediated whole cell current densities than ciliary neurons (McNerney et al., 2000). Furthermore, $\alpha 7$ -containing nAChRs in choroid neurons may be qualitatively different from those in ciliary neurons. Recent data show that $\alpha 7$ -nAChRs can adopt multiple conductance states and, as a result, ciliary ganglion neurons display heterogeneous $\alpha 7$ -nAChR-mediated whole-cell currents (McNerney et al., 2000; Nai et al., 2003). These heterogeneous conductance states of $\alpha 7$ -nAChR might arise from different affinities of distinct $\alpha 7$ -nAChRs subclasses for PSCA and other prototoxins. If choroid neurons express higher number of $\alpha 7$ -nAChRs with high affinity for PSCA than ciliary neurons, overexpressing PSCA in the ciliary ganglion

would preferentially prevent choroid neurons from dying. We have also found that two other members of Ly6 superfamily are expressed in the ciliary ganglion but are not developmentally regulated. These prototoxins may act with higher efficacy on ciliary neurons.

The relationship of PSCA expressed in the prostate to its expression in the nervous system is not clear. PSCA was first identified as an antigen enriched in basal cells of the prostate epithelium that is upregulated in high grade, metastatic prostate tumors (Reiter et al., 1998), suggesting that it promotes cell proliferation. Currently, it is unknown whether PSCA modulates $\alpha 7$ -nAChRs signaling in the prostate or whether it has completely unrelated function. However, many non-neural cells, such as keratinocytes, lymphocytes, endothelial cells and glia, express $\alpha 7$ -nAChRs (Benhammou et al., 2000; Macklin et al., 1998; Sharma and Vijayaraghavan, 2001; Smit et al., 2001; Zia et al., 2000). In fact, inhibition of $\alpha 7$ -nAChRs by α btx prevents terminal differentiation of human keratinocytes, suggesting that $\alpha 7$ -nAChRs play an important role in proliferation of these cells (Arredondo et al., 2002). It is possible that $\alpha 7$ -nAChR signaling also regulates cell proliferation in the prostate. Therefore, uncovering the neural and non-neural functions of nAChRs and their accompanying prototoxin modulators will be key for understanding the importance of nicotinic signaling in normal physiology and disease.

SUPPLEMENTAL MATERIAL

Supplemental Table 1: Chicken lynx specific sequence primer

Name	TC# ^a	Forward primer (5' → 3')	Reverse primer (5' → 3')
Ch1Ly	TC935	CAACCACATACAGTGCTGCTGG	CAATCCTGCCCTAATGACAC
Ch2Ly	TC877	TTCTTGTCGTGCTTGTCAATTGC	CGGTCATCGCCGAGTCCCTTAG
Ch3Ly	TC810	CTCATCTGCTTTTCGTGCTCG	AGACTTGCCACCGATTCCCCTC
Ch4Ly	TC870	TTGTCCTGTGCGTTGGAGTGGT	CGAGGGAGGTTTGTATGATGGC
Ch5Ly	TC928	CATCGGTCACCAAAAAATGTGC	AAACACATTCTGTGTGACCAC
Ch6Ly	TC654	GGTTTTCTTCATCCTCCTGCTGG	ATCCCTGCTGCCATTCCATAG

^aChicken lynx sequence specific primers were designed by searching chicken EST database (<http://www.tigr.org/tdb/tgi/>) using the specified TC accession numbers.

Supplemental Table 2: Chicken-specific real-time PCR primers and probes

Name	Forward primer (5' → 3')	Reverse primer (5' → 3')	Probe (5'FAM → 3' BHQ)*
α3 subun.	CGCTCTCCTTAACTGCTG	GCGGACGAAGTGGTTGTAG	AGCCCGAGCACCGGCTGTAC
α7 subun.	ATCTGCCACCAGGCATATTT	CAGCCTCCATATGTCCAAGA	CGTGCGTTGGTTTCCATTTGATG
chPSCA	TTTTCTTCATCCTCCTGCTG	GCACATTTCAATTTTCCTTGC	TCAGCAACAGCAACTGTCAGGCC
chrps	AACGACTCCACACCAACAA	CTTCATCAGGTGGGTGACAT	CGCCATCATCCCCAGCAAGA
Islet-1	GTCCGGAGAGACATGATGGT	CGTATCTGGGAGCTGAGAGG	TTTACAGGCGAACCCGGTGGGA

EXPERIMENTAL PROCEDURES

Identification of chicken lynx sequences: Mouse lynx1 and lynx2 protein sequences were blasted against chicken TIGR gene indices (<http://www.tigr.org/tdb/tgi/>) and we chose 6 sequences (accession number for each sequence is shown in supplemental table 1) that fit the following criteria: 1) to have the Ly6 domain as the only functional domain; 2) to match the exon-intron structures of Lynx1 and other toxins that have the Ly6 domain. Based on predicted sequences, the sequence specific primers were used to identify the expression profile of lynx related transcripts in the ciliary ganglion between E8 and E15 (see Supplemental Table 1).

RNA extraction and PSCA cloning: Tissues were isolated at the indicated stages of development and rapidly frozen on dry ice. Total RNA was extracted by using TRI reagent (Molecular Research Center Inc., Cincinnati). The cDNA was synthesized from 2 µg of total RNA by reverse transcription using Oligo dTs and Superscripts II Reverse transcriptase (Invitrogen). The full length PSCA was obtained by PCR using forward primer (5' ccatggtaatgaaggtttcttcacctcc 3') that attached Nco1 restriction site to the 5' end of a PSCA sequence and reverse primer (5' ggatcccttcacagtctgtgttcagg 3') that added BamH1 restriction site to the 3' end of PSCA sequence. The 369 base pair PCR product was cloned into Nco1 and BamH1 cloning sites on pSlax13Nco vector and the sequencing confirmed that it was in fact full-length chicken PSCA sequence.

Real-time PCR: Tissues were isolated at indicated ages and rapidly frozen on dry ice. Total RNA was extracted and cDNA was synthesized as described above. The expression profile of $\alpha 7$ -nAChRs, $\alpha 3$ -nAChRs and PSCA was assessed using 7500 Fast Real-Time PCR System (Applied Biosystems, Foster City, CA) and their expression in chicken tissues was normalized to the endogenous gene control (chicken S17 ribosomal binding protein-*chrps*), which is constitutively expressed in all cells or to *Islet-1*, a neural-specific transcription factor. Primers and probes were designed using a primer design website at Whitehead Institute at MIT (http://frodo.wi.mit.edu/cgi-bin/primer3/primer3_www.cgi; see Supplemental Table 2). The probes were labeled with 6 FAM reporter dye at their 5' ends and black hole quencher (BHQ) at their 3' ends. The transcript expression and number was determined using Sequence Detection Software (SDS) version 1.4. PSCA expression in mouse tissues was normalized to β -actin using Assays on Demand from Applied Biosystems (PSCA: Mm00452908_m1; β -actin: Mm00607939_s1).

Expression of PSCA with a viral vector: The PSCA sequence was cloned into the Slax13NCO1 shuttle vector using 5' Nco1 and 3' BamH1 sites (Morgan and Fekete, 1996); the insert was removed from Slax13NCO1 by cutting with Cla1, and cloned into the avian retroviral vector RCASBP(A) (Federspiel and Hughes, 1997). Infective RCASBP(A)-PSCA viral particles were generated by transfecting DF-1 chicken fibroblast cells with 800 ng of RCASBP(A)-PSCA plasmid using Mirus TransIT-LT transfection reagent (Mirus Bio Corporation, Madison, WI). Conditioned media

containing viral stocks collected from DF-1 cells were concentrated approximately 20-fold by ultracentrifugation at 90,000 x g at 4°C for 3 hr (Morgan and Fekete, 1996). Concentrated stocks were titered by limiting dilution and infectivity of cells as measured by staining with p27gag antibody. Stocks with concentration of $>10^8$ infectious particles/ml were used for *in vivo* injection. Viral particles (60-120 nL) were injected into the mesencephalic enlargement of the neural tube of Hamburger/Hamilton stage (St.) 8-9 or St. 10-13 embryos using a Drummond Nanoject microinjector (Drummond Scientific, Broomall, PA). The shells were sealed with a glass coverslip and sterile vacuum grease and incubated at 37°C to the desired stage.

Calcium imaging: Acutely isolated ciliary ganglion neurons were loaded with Fura-2 AM (Invitrogen) dissolved in DMSO at final concentration of 5 μ M with 2% Pluronic F-127 (Invitrogen). Neurons were loaded at room temperature for 30 min in the dark. Calcium signals were recorded by exposure to alternating wavelength (340 and 380 nm, 50 ms) generated by a Xenon light source and Lambda DG-4 ultra high-speed wavelengths switcher (Sutter Instruments, Novato, CA). Fluorescent responses were recorded using an Orca-ER digital camera (Hamamatsu, Bridgewater, NJ). Paired 340/380 ratio images were acquired at 4s intervals with Metaflour 5.0r5 software (Molecular Devices Corp, Downingtown, PA). Drugs were dissolved in chicken physiological buffer (145 mM NaCl, 5.4 mM KCl, 0.8 mM MgCl₂, 5.4 mM CaCl₂, 5 mM glucose, 13 mM HEPES, pH 7.4). Voltage gated sodium and calcium channels were blocked by supplementing the perfusion medium with 600 nM tetrodotoxin (Tocris, Ellisville, MO) and 200 μ M cobalt

chloride (Sigma), respectively. 10 μ M Nicotine (Sigma) was applied for 20 sec to activate nAChRs. α 7-nAChRs were inhibited by perfusing the neurons with 50 nM α -methyllycaconitine citrate hydrate (MLA) (Sigma) for 1min or pre-incubating with 50 nM α btx (Sigma) for 30 min at 25°C. Upon completion of these experiments, the extent of dye loading was determined by activating voltage-gated calcium channels with high potassium perfusion solution (25 mM KCl, with no TTX or cobalt chloride). After the initial recordings were performed, background was subtracted from every image acquired and new ratios were calculated using the Metafluor 5.0r5 software. The ratios were then exported into the Microsoft Excel spreadsheet and all the calculations were performed using Microsoft Excel.

Tissues were prepared for immunohistochemistry as follows: Ciliary ganglia and brainstems from E14 embryos were harvested, fixed in Zamboni's for 48 hours at 4°C, washed, then equilibrated in 30% sucrose at 4°C. Tissue was embedded in Microm cryo-embedding compound (Richard Allen Scientific, Kalamazoo, MI), sectioned on a Microm HM 560 cryostat (Richard Allen Scientific) at 30 μ m, and collected on Superfrost Plus slides (Fisher Scientific, Pittsburgh, PA). Sections were post-fixed in Zamboni's vapors for 15 min at 37°C, submerged in Zamboni's fixative for additional 15 min at 25°C, washed in PBS and blocked. Primary antibodies were incubated overnight at 4°C and secondary antibodies were incubated 2 hr at room temperature.

Primary antibodies and the dilutions in blocking buffer at which they were used were: mouse anti-Islet-1, which recognizes a transcription factor expressed in ciliary ganglion neurons (Lee et al., 2001) at 1:100 dilution of the culture supernatant (prepared in the Nishi Lab from clone 39.4D5, DSHB); mouse anti-Hu C/D (Invitrogen), which recognizes a neuron-specific RNA binding protein (Lee et al., 2001; Marusich and Weston, 1992) at 1:250 dilution of the culture supernatant; rabbit anti-p27gag (SPAFAS, Norwich, CT), which recognizes avian sarcoma gag p27 (Wang et al., 1976) at 1:1000; rat anti-somatostatin (Product #: YMC1020, Accurate Chemical & Scientific corporation, Westbury, NY) diluted 1:100.

Secondary antibodies: biotinylated anti-mouse (Vector Laboratories, Burlingame, CA) at 1:250; biotinylated anti-rabbit (Vector Laboratories) at 1:250; goat anti-mouse Cy3 (Jackson Immuno Research, West Grove, PA) at 1:750; goat anti-rabbit Alexa 488 (Invitrogen) at 1:750; and goat anti-rat Cy3 (Jackson Immuno Research) at 1:750.

Images of ciliary ganglia and midbrain were acquired with 20x objective using Nikon C1 confocal scanner (Nikon Instruments Inc., Melville, NY) attached to a Nikon Eclipse E800 microscope (Micro Video Instruments, Avon, MA).

Design-based stereology: Serially sectioned ciliary ganglia (cut at 30 μm) were prepared for design-based stereology as previously described (Bunker and Nishi, 2002) and Islet-1 positive nuclei (representing all neurons) together with somatostatin-positive cell bodies (representing all choroid neurons) were counted using the Optical Dissector Probe

of Stereo Investigator (MBF Biosciences, Williston, VT) in conjunction with a Nikon Optiphot 2 microscope with a Hitachi HVC20 camera, Heidenhain focus encoder, and a motorized, computer-driven X, Y, Z stage (all microscope attachments provided by MBF Biosciences). To avoid inaccuracies caused by cutting artifacts and double counting between adjacent sections, an upper guard of 4 μm and lower guard of 7 μm were used (Bunker and Nishi, 2002). Spacing between sampling sites (grid size) was set such that 13-15 sampling sites were counted per section, which yielded 100-300 objects per each ciliary ganglion. The number of ciliary neurons was calculated by subtracting the number of somatostatin-positive neurons from the total number of neurons per ciliary ganglion (Bunker and Nishi, 2002).

REFERENCES

- Arredondo, J., Nguyen, V.T., Chernyavsky, A.I., Bercovich, D., Orr-Urtreger, A., Kummer, W., Lips, K., Vetter, D.E., and Grando, S.A. (2002). Central role of alpha7 nicotinic receptor in differentiation of the stratified squamous epithelium. *The Journal of cell biology* 159, 325-336.
- Benhammou, K., Lee, M., Strook, M., Sullivan, B., Logel, J., Raschen, K., Gotti, C., and Leonard, S. (2000). [(3)H]Nicotine binding in peripheral blood cells of smokers is correlated with the number of cigarettes smoked per day. *Neuropharmacology* 39, 2818-2829.
- Berg, D.K., and Conroy, W.G. (2002). Nicotinic alpha 7 receptors: synaptic options and downstream signaling in neurons. *Journal of neurobiology* 53, 512-523.
- Berger, F., Gage, F.H., and Vijayaraghavan, S. (1998). Nicotinic receptor-induced apoptotic cell death of hippocampal progenitor cells. *J Neurosci* 18, 6871-6881.
- Betzl, C., Lange, G., Pal, G.P., Wilson, K.S., Maelicke, A., and Saenger, W. (1991). The refined crystal structure of alpha-cobratoxin from *Naja naja siamensis* at 2.4-A resolution. *The Journal of biological chemistry* 266, 21530-21536.

Blumenthal, E.M., Shoop, R.D., and Berg, D.K. (1999). Developmental changes in the nicotinic responses of ciliary ganglion neurons. *J Neurophysiol* 81, 111-120.

Bunker, G.L., and Nishi, R. (2002). Developmental cell death in vivo: rescue of neurons independently of changes at target tissues. *J Comp Neurol* 452, 80-92.

Chang, K.T., and Berg, D.K. (2001). Voltage-gated channels block nicotinic regulation of CREB phosphorylation and gene expression in neurons. *Neuron* 32, 855-865.

Chimienti, F., Hogg, R.C., Plantard, L., Lehmann, C., Brakch, N., Fischer, J., Huber, M., Bertrand, D., and Hohl, D. (2003). Identification of SLURP-1 as an epidermal neuromodulator explains the clinical phenotype of Mal de Meleda. *Human molecular genetics* 12, 3017-3024.

Conroy, W.G., and Berg, D.K. (1995). Neurons can maintain multiple classes of nicotinic acetylcholine receptors distinguished by different subunit compositions. *The Journal of biological chemistry* 270, 4424-4431.

Coulombe, J.N., Schwall, R., Parent, A.S., Eckenstein, F.P., and Nishi, R. (1993). Induction of somatostatin immunoreactivity in cultured ciliary ganglion neurons by activin in choroid cell-conditioned medium. *Neuron* 10, 899-906.

Dani, J.A. (2001). Overview of nicotinic receptors and their roles in the central nervous system. *Biol Psychiatry* 49, 166-174.

Dani, J.A., and Bertrand, D. (2007). Nicotinic acetylcholine receptors and nicotinic cholinergic mechanisms of the central nervous system. *Annual review of pharmacology and toxicology* 47, 699-729.

Dessaud, E., Salaun, D., Gayet, O., Chabbert, M., and deLapeyriere, O. (2006). Identification of lynx2, a novel member of the ly-6/neurotoxin superfamily, expressed in neuronal subpopulations during mouse development. *Molecular and cellular neurosciences* 31, 232-242.

Epstein, M.L., Davis, J.P., Gellman, L.E., Lamb, J.R., and Dahl, J.L. (1988). Cholinergic neurons of the chicken ciliary ganglion contain somatostatin. *Neuroscience* 25, 1053-1060.

Federspiel, M.J., and Hughes, S.H. (1997). Retroviral gene delivery. *Methods Cell Biol* 52, 179-214.

Furber, S., Oppenheim, R.W., and Prevet, D. (1987). Naturally-occurring neuron death in the ciliary ganglion of the chick embryo following removal of preganglionic input: evidence for the role of afferents in ganglion cell survival. *J Neurosci* 7, 1816-1832.

Gumley, T.P., McKenzie, I.F., and Sandrin, M.S. (1995). Tissue expression, structure and function of the murine Ly-6 family of molecules. *Immunology and cell biology* 73, 277-296.

Horie, M., Okutomi, K., Taniguchi, Y., Ohbuchi, Y., Suzuki, M., and Takahashi, E. (1998). Isolation and characterization of a new member of the human Ly6 gene family (LY6H). *Genomics* 53, 365-368.

Ibanez-Tallon, I., Miwa, J.M., Wang, H.L., Adams, N.C., Crabtree, G.W., Sine, S.M., and Heintz, N. (2002). Novel modulation of neuronal nicotinic acetylcholine receptors by association with the endogenous prototoxin lynx1. *Neuron* 33, 893-903.

Landmesser, L., and Pilar, G. (1972). The onset and development of transmission in the chick ciliary ganglion. *J Physiol (Lond)* 222, 691-713.

Landmesser, L., and Pilar, G. (1974). Synaptic transmission and cell death during normal ganglionic development. *J Physiol* 241, 737-749.

Lee, V.M. (2001). Regulation of neuronal cell number in the developing ciliary ganglion. In *Cell and Developmental Biology* (Portland, Oregon Health Sciences University), p. 137.

Lee, V.M., Smiley, G.G., and Nishi, R. (2001). Cell death and neuronal replacement during formation of the avian ciliary ganglion. *Dev Biol* 233, 437-448.

Macklin, K.D., Maus, A.D., Pereira, E.F., Albuquerque, E.X., and Conti-Fine, B.M. (1998). Human vascular endothelial cells express functional nicotinic acetylcholine receptors. *The Journal of pharmacology and experimental therapeutics* 287, 435-439.

Maderdrut, J.L., Oppenheim, R.W., and Prevet, D. (1988). Enhancement of naturally occurring cell death in the sympathetic and parasympathetic ganglia of the chicken embryo following blockade of ganglionic transmission. *Brain Res* 444, 189-194.

Marusich, M.F., and Weston, J.A. (1992). Identification of early neurogenic cells in the neural crest lineage. *Developmental biology* 149, 295-306.

McNerney, M.E., Pardi, D., Pugh, P.C., Nai, Q., and Margiotta, J.F. (2000). Expression and channel properties of alpha-bungarotoxin-sensitive acetylcholine receptors on chick ciliary and choroid neurons. *J Neurophysiol* 84, 1314-1329.

Meriney, S.D., Pilar, G., Ogawa, M., and Nunez, R. (1987). Differential neuronal survival in the avian ciliary ganglion after chronic acetylcholine receptor blockade. *J. Neurosci.* 7, 3840-3849.

Miwa, J.M., Ibanez-Tallon, I., Crabtree, G.W., Sanchez, R., Sali, A., Role, L.W., and Heintz, N. (1999). lynx1, an endogenous toxin-like modulator of nicotinic acetylcholine receptors in the mammalian CNS. *Neuron* 23, 105-114.

Miwa, J.M., Stevens, T.R., King, S.L., Caldarone, B.J., Ibanez-Tallon, I., Xiao, C., Fitzsimonds, R.M., Pavlides, C., Lester, H.A., Picciotto, M.R., and Heintz, N. (2006). The prototoxin lynx1 acts on nicotinic acetylcholine receptors to balance neuronal activity and survival in vivo. *Neuron* 51, 587-600.

Morgan, B.A., and Fekete, D.M. (1996). Manipulating gene expression with replication-competent retroviruses. *Methods Cell Biol* 51, 185-218.

Nai, Q., McIntosh, J.M., and Margiotta, J.F. (2003). Relating neuronal nicotinic acetylcholine receptor subtypes defined by subunit composition and channel function. *Mol Pharmacol* 63, 311-324.

Pittman, R., and Oppenheim, R.W. (1978). Neuromuscular blockade increases motoneurone survival during normal cell death in the chick embryo. *Nature* 271, 364-366.

Pittman, R., and Oppenheim, R.W. (1979). Cell death of motoneurons in the chick embryo spinal cord. IV. Evidence that a functional neuromuscular interaction is involved

in the regulation of naturally occurring cell death and the stabilization of synapses. *J Comp Neurol* *187*, 425-446.

Pugh, P.C., and Margiotta, J.F. (2000). Nicotinic acetylcholine receptor agonists promote survival and reduce apoptosis of chick ciliary ganglion neurons. *Molecular and cellular neurosciences* *15*, 113-122.

Reiter, R.E., Gu, Z., Watabe, T., Thomas, G., Szigeti, K., Davis, E., Wahl, M., Nisitani, S., Yamashiro, J., Le Beau, M.M., *et al.* (1998). Prostate stem cell antigen: a cell surface marker overexpressed in prostate cancer. *Proceedings of the National Academy of Sciences of the United States of America* *95*, 1735-1740.

Rezvani, A.H., and Levin, E.D. (2001). Cognitive effects of nicotine. *Biol Psychiatry* *49*, 258-267.

Role, L.W., and Berg, D.K. (1996). Nicotinic receptors in the development and modulation of CNS synapses. *Neuron* *16*, 1077-1085.

Sharma, G., and Vijayaraghavan, S. (2001). Nicotinic cholinergic signaling in hippocampal astrocytes involves calcium-induced calcium release from intracellular stores. *Proceedings of the National Academy of Sciences of the United States of America* *98*, 4148-4153.

Sharma, G., and Vijayaraghavan, S. (2002). Nicotinic receptor signaling in nonexcitable cells. *Journal of neurobiology* 53, 524-534.

Shoop, R., Chang, K., Ellisman, M., and Berg, D. (2001). Synaptically driven calcium transients via nicotinic receptors on somatic spines. *J Neurosci* 21, 771-781.

Shoop, R.D., Martone, M.E., Yamada, N., Ellisman, M.H., and Berg, D.K. (1999). Neuronal acetylcholine receptors with alpha7 subunits are concentrated on somatic spines for synaptic signaling in embryonic chick ciliary ganglia. *J Neurosci* 19, 692-704.

Smit, A.B., Syed, N.I., Schaap, D., van Minnen, J., Klumperman, J., Kits, K.S., Lodder, H., van der Schors, R.C., van Elk, R., Sorgedrager, B., *et al.* (2001). A glia-derived acetylcholine-binding protein that modulates synaptic transmission. *Nature* 411, 261-268.

Tsetlin, V. (1999). Snake venom alpha-neurotoxins and other 'three-finger' proteins. *European journal of biochemistry / FEBS* 264, 281-286.

Wang, L., Galehouse, D., Mellon, P., Duesberg, P., Mason, W.S., and Vogt, P.K. (1976). Mapping oligonucleotides of Rous sarcoma virus RNA that segregate with polymerase and group-specific antigen markers in recombinants. *Proceedings of the National Academy of Sciences of the United States of America* 73, 3952-3956.

Wright, L. (1981). Cell survival in chick embryo ciliary ganglion is reduced by chronic ganglionic blockade. *Brain Res* 227, 283-286.

Zia, S., Ndoye, A., Lee, T.X., Webber, R.J., and Grando, S.A. (2000). Receptor-mediated inhibition of keratinocyte migration by nicotine involves modulations of calcium influx and intracellular concentration. *The Journal of pharmacology and experimental therapeutics* 293, 973-981.

FIGURE LEGENDS AND FIGURES

Figure 1. Expression of molecules with homologies to the Ly6/Neurotoxin superfamily in chicken ciliary ganglion.

(A) Chicken EST databases were searched for the sequences with amino acid homologies to mouse *lynx1* and *lynx2*. Six sequences were identified. All sequences have the same intron-exon breaks as mouse *lynx1* and contain Ly6 functional domain (in bold at the bottom). Open reading frame of all six molecules contains the N-terminal signal sequence and consensus sequence for the addition of the GPI anchor at their C-terminal.

(B) Sequence specific primers were used to amplify cDNA from E8 and E15 ciliary ganglia. Three chicken specific *lynx* sequences are expressed in the ciliary ganglion. The *ch3Ly* and *ch5Ly* are present at E8 and E15. The *ch6Ly* is not expressed at E8 but is expressed at E15. *Chrps* codes for the ribosomal binding protein expressed ubiquitously in the ciliary ganglion.

Figure 2. The *ch6Ly* is prostate stem cell antigen.

(A) The amino acid sequence of *ch6Ly* was used to search NCBI and Ensembl databases and the mouse *PSCA* sequence was pulled down in the search. The two sequences share 80% homology and 40% identity. Black highlight indicates positions with single, fully conserved residues. Dark grey highlight indicates that the strong amino acid groups are fully conserved. Light grey highlight represents the fully conserved weak amino acid groups. Both molecules contain cysteine-rich Ly6 domain (shown above the amino acid sequence) with conserved N-terminal leucine and C-terminal asparagine. (B) Representation of the coding sequence of *ch6Ly* and mouse *pzca* as compared to the other members of Ly6/Neurotoxin superfamily such as *lynx1*, *ly6h*, *α -bungarotoxin*. The *ch6ly* and *pzca* have the same intro/exon breaks as the other members of the superfamily. 5' UTR sequence, signal sequence, mature protein containing Ly6 domain, hydrophobic GPI anchor and 3'UTR sequence are also conserved between *ch6ly*, *pzca* and other members of the family.

A

```

                                L--C--C-----C-----C-----C-----
Ch6Ly  MKVFFI LLLAAILCTDPGSSLQCYSCKTKLSNSNCQATMNCKENE-MCKTDVIRVIGFF
mPSCA  MKTVFF LLLATYLALHPGAALQCYSCTAQMNRDCLNVQNCSLDQHSCTSRIRAIGLV
      **..*:*:**: * . **:*:**:***:.....* :* . ** . : : * * . **:*:**:
-----C---C-----CC-----CN
SIISKGCEASCQEDYQDFKVGNRNVSCSTNLCNVNAAGSVR--SSYGMAAGTISASLLWTFLNNRL
TVISKGSSQCEDDSENYYLGKKNITCCYSDLCNVNGAHTLKPPTTLGLLTVLCSLLWSS--RL
:*****. :.*:* : : : *:*:**:***:*****.* : : : : * : : : : * * **

```

B

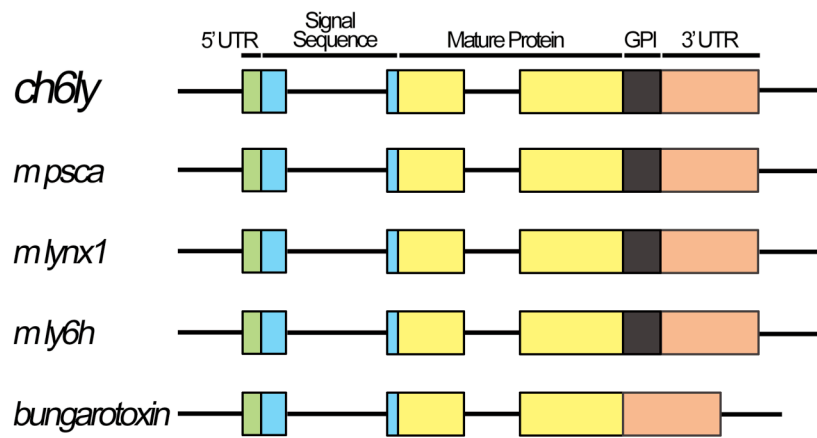

Figure 3. Quantification of PSCA transcript expression.

The PSCA mRNA transcripts from different tissues of E15 chicken embryos were quantified using the real-time PCR and normalized to ubiquitously expressed chicken ribosomal protein s17 or neuronal-specific transcription factor Islet-1. (A) The expression of PSCA in various tissues correlates with the expression levels of $\alpha 7$ - and $\alpha 3$ - subunits of nAChR. There is a tighter correlation between PSCA and $\alpha 7$ subunit ($r^2=0.8$) than between PSCA and $\alpha 3$ subunit ($r^2=0.5$). (B) PSCA expression is developmentally regulated in the chicken ciliary ganglion. The PSCA transcript levels were normalized to Islet-1 (neuronal specific transcription factor) to account for 50% decrease in neuronal numbers between E8 and E15. The levels of PSCA mRNA are the lowest at E8 and increase 100-fold by E13 ($p<0.05$). By E15 the levels of PSCA increase 10^6 -fold when compared to E14 ($p<0.001$, one-way ANOVA, Tukey's multiple comparison post hoc). Values represent mean \pm SEM from at least 3 separate experiments.

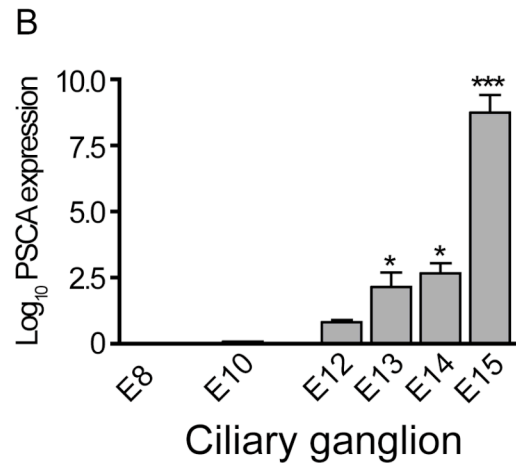
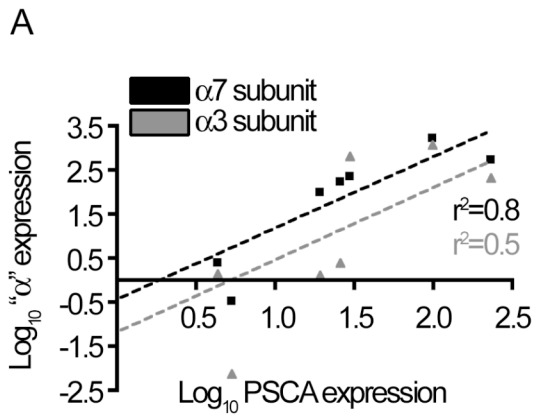

Figure 4. Misexpression of chicken PSCA using RCASBP(A) retrovirus.

Embryos were injected with RCASBP(A)-PSCA at 36 hrs of development (St. 8-9; A-C) and 48 hrs of development (St. 10-13, D-F). (A-C) p27 gag immunoreactivity (green) is observed in >80% of neurons (red) in ciliary ganglia from embryos infected at St. 8-9. (D-F) Only surrounding non-neural tissue exhibits p27gag immunoreactivity in the ciliary ganglia from embryos infected at St. 10-13. Calibration bar = 100 μm . (G-H) Neurons in the AON from the embryos injected at St. 8-9 are not infected and only surrounding glia exhibits p27gag immunoreactivity. Calibration bar = 250 μm (inset = 50 μm).

—— RCASBP(A)-PSCA ——

AON St. 8-9 E15 CG St. 10-13 E15 CG St. 8-9

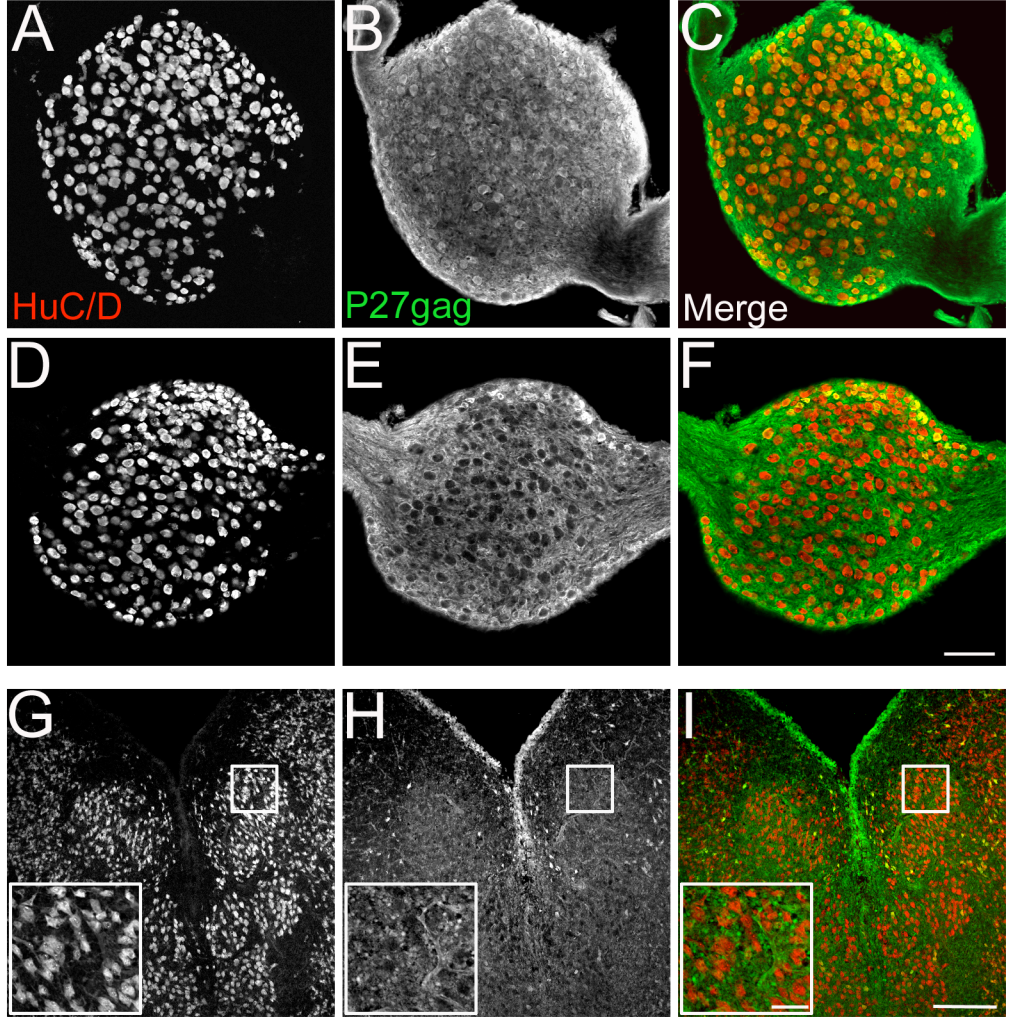

Figure 5. Overexpression of PSCA at E8 blocks nicotine-induced calcium influx via $\alpha 7$ -nAChRs.

Ciliary ganglion neurons from embryos infected with RCASBP(A)-PSCA at St. 8-9 were acutely dissociated and loaded with fura-2. 10 μ M nicotine was used to stimulate nAChRs in the presence TTX and cobalt. (A) Brief application of nicotine induces rapid increase in $[Ca^{2+}]_i$. 50% of this nicotinic response is blocked by $\alpha 7$ -specific antagonist MLA. (B) The Ca^{2+} responses due to depolarization with 25 mM KCl are not different between open and PSCA infected ciliary ganglion neurons, indicating the all neurons are equally loaded. (C) PSCA infected neurons exhibit significantly smaller nicotine-induced increases in $[Ca^{2+}]_i$ compared to open-infected neurons ($p < 0.0001$, Student t-test; open: 0.3 ± 0.02 , $n=69$; PSCA: 0.17 ± 0.01 , $n=86$). Addition of α btx (50 nM) to PSCA infected neurons does not cause additional reduction in nicotine-induced Ca^{2+} while addition of α btx into open infected neurons significantly reduces increases in $[Ca^{2+}]_i$ ($p < 0.0001$, Student t-test, open: 0.3 ± 0.02 , $n=69$; open+btx: 0.14 ± 0.02 $n=31$). Values represent mean \pm SEM of three separate experiments.

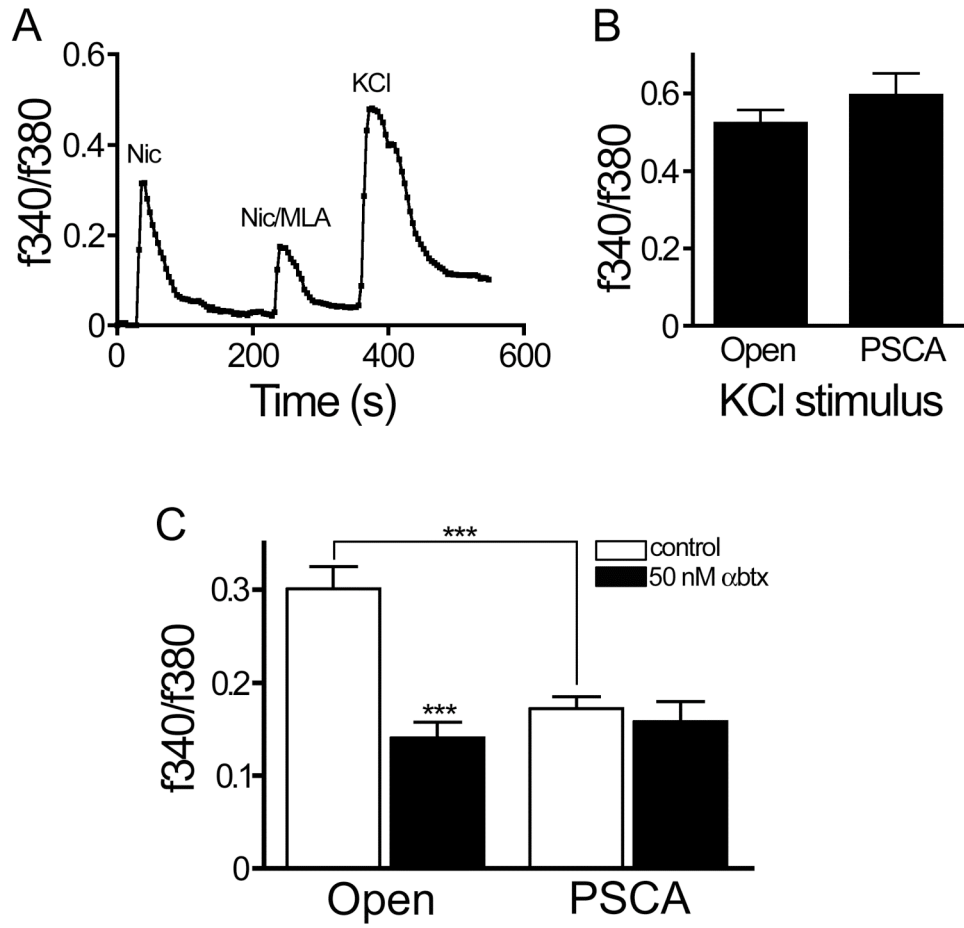
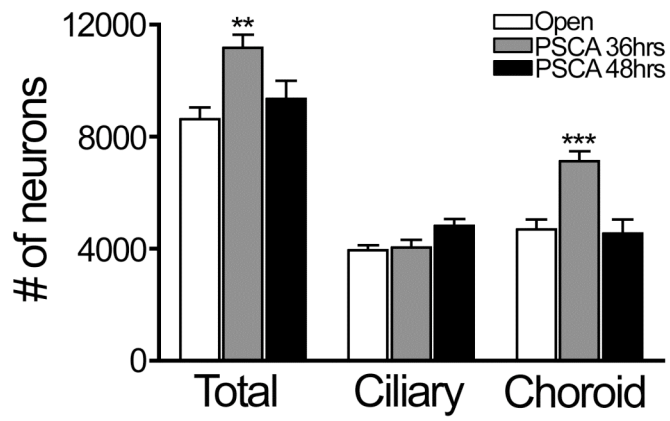

Figure 6. Misexpression of PSCA rescues choroid, but not ciliary neurons.

Serially sectioned E14 ciliary ganglia infected with RCASBP(A)-PSCA at St. 8-9 (36 hrs of incubation) or St. 10-13 (48 hrs of incubation) were labeled with Islet-1 antibody to stain all the neurons and somatostatin antibody to label choroid neurons. Number of surviving neurons was determined using design-based stereology. Ciliary ganglia infected at St. 8-9 have significantly more choroid neurons ($p < 0.0001$; open: 4679 ± 353.4 , $n=16$; PSCA at 36hrs: 7125 ± 355.1 , $n=13$) compared to the open-infected ganglia. The number of ciliary neurons is the same in open and RCASBP(A)-PSCA infected ciliary ganglia. The total number of neurons is also significantly greater in RCASBP(A)-PSCA ganglia infected at St. 8-9 ($p < 0.002$). Infection at St. 10-13 does not prevent cell death of ciliary or choroid neurons. Values represent mean \pm SEM of three or more separate experiments. One-way ANOVA with Tukey's multiple comparison post hoc was used to analyze the results.



TABLES

Table 1. Relative real-time PCR quantification of transcripts in tissues from E15 chicken embryos

<i>Tissue type</i>	Gene quantification (arbitrary units)		
	<i>PSCA</i>	<i>α3 subunit</i>	<i>α7 subunit</i>
Heart	4.55 ± 4.22	3.94 ± 2.14	1.7 ± 0.87
Liver	11.36 ± 5.44	0.009 ± 0.003	0.66 ± 0.38
Pectoral muscle	6.02 ± 2.87	1.47 ± 0.18	4.08 ± 2.48
Telencephalon	42.47 ± 28.84	2.6 ± 0.41	194 ± 56.54
Cerebellum	6.74 ± 6.18	1.42 ± 0.38	107.9 ± 28.08
Ciliary Ganglion	288.3 ± 131.8*	352 ± 241.6	1176 ± 905.9
Sympathetic Ganglia	100.6 ± 16.07	1452 ± 637.3*	1826 ± 453.9
DRG	29.58	668.4 ± 4.63	230.2 ± 1.675

The mRNA transcripts from different tissues of E15 chicken embryos were quantified using the real-time PCR and normalized to ubiquitously expressed chicken ribosomal protein s17. *Significant difference: $p < 0.05$, one-way ANOVA, Tukey's multiple comparison post hoc. Values represent mean ± SEM from three different animals.

Table 2. Relative real-time PCR quantification of PSCA transcript in adult mouse tissue

<i>Tissue type</i>	Gene (Arbitrary units)
	<i>PSCA</i>
Liver	3.06 ± 1.63
Spleen	2.142
Telencephalon	20.28 ± 1.79
Cerebellum	14.42 ± 0.86
SCG	58.78 ± 18.08***

PSCA levels in adult mouse tissues were quantified and normalized to β -actin. PSCA is preferentially upregulated in the nervous system. ***Significant difference: $p < 0.001$, one-way ANOVA, Tukey's multiple comparison post hoc. Values represent mean \pm SEM from three different animals. Spleen was collected only from a single animal.

CHAPTER 4

SUMMARY AND CONCLUSIONS

The principal finding in this dissertation shows that the activation of $\alpha 7$ -nAChRs on the ciliary ganglion neurons facilitates neuronal cell death, likely by increasing the levels of $[Ca^{2+}]_i$. Later in the development of the ciliary ganglion, a steady upregulation of the chicken PSCA molecule causes the reduction of Ca^{2+} influx via $\alpha 7$ -nAChRs and prevents choroid neurons from dying. At the same time, mature neurons become more efficient in intracellular Ca^{2+} handling and, thus, become more resistant to the $\alpha 7$ -nAChR-induced Ca^{2+} insults. These results show that in addition to the competition for target-derived factors, anterograde influences play an important role in regulating neuronal survival.

Based on these observations, I propose the following model of cell death in the developing ciliary ganglion (summarized in Figure 1). Ciliary ganglion neurons receive preganglionic innervation at E 5.5 and transmission through the ganglion is 100% functional by E8 (Landmesser and Pilar, 1972). By E8, ciliary ganglion neurons already express $\alpha 7$ -nAChRs (Corriveau and Berg, 1993; Brumwell et al., 2002); however, the neurons are heterogeneous with respect to surface $\alpha 7$ -nAChR levels. Therefore, the binding of ACh to $\alpha 7$ -nAChRs leads to large increases in $[Ca^{2+}]_i$ in some neurons. If these neurons are unable to buffer the $[Ca^{2+}]_i$ or reduce the Ca^{2+} influx via $\alpha 7$ -nAChRs, they die as a result of apoptosis. The intracellular concentration of Ca^{2+} in neurons with

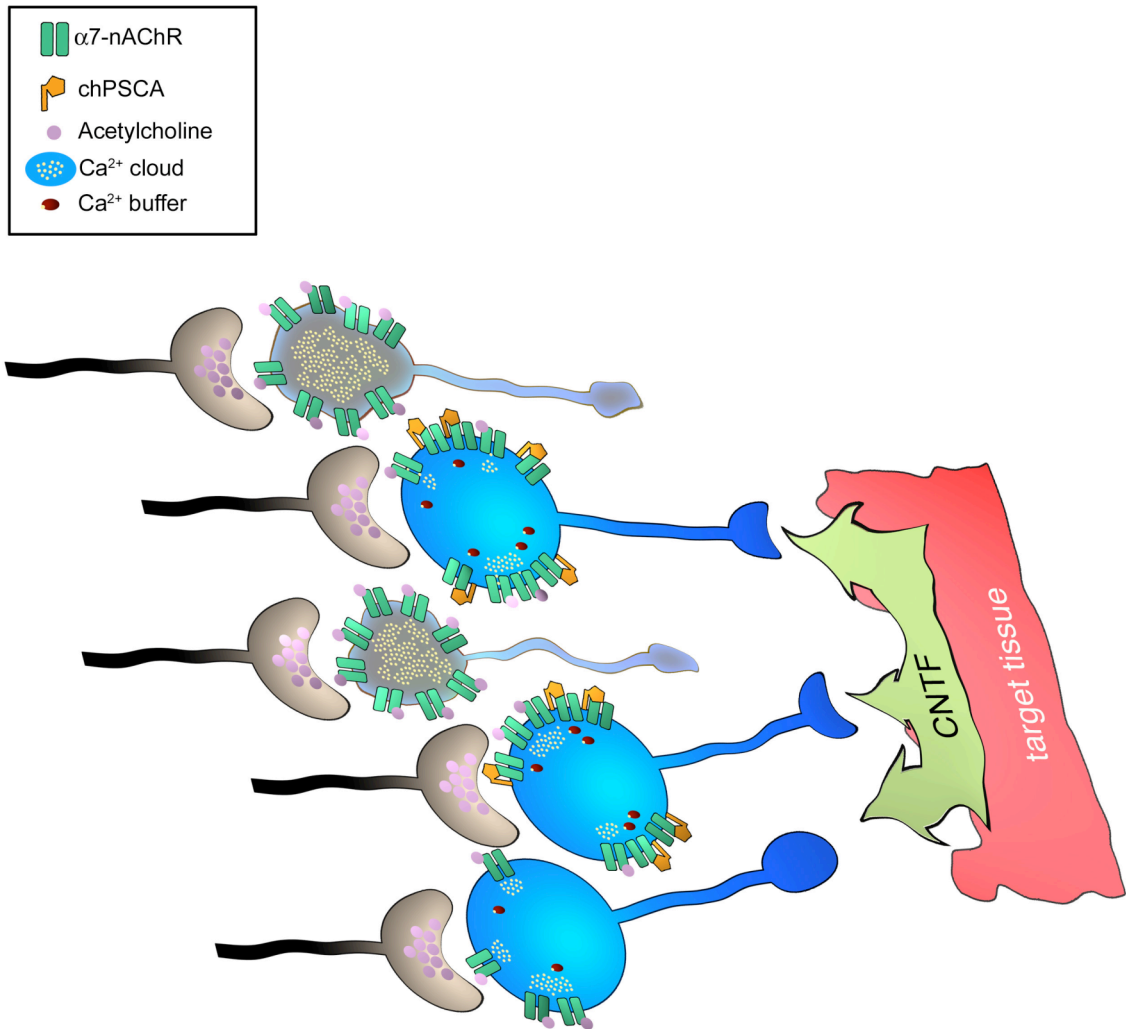

Figure 1. A model of cell death in the ciliary ganglion.

At E8, ciliary ganglion neurons express heterogeneous levels of surface $\alpha 7$ -nAChRs, which leads to the large global increases in $[\text{Ca}^{2+}]_i$ in some neurons but not others. A lack of Ca^{2+} buffers in immature neurons with too many $\alpha 7$ -nAChRs allows $[\text{Ca}^{2+}]_i$ to reach the threshold for cell death. In contrast, the $[\text{Ca}^{2+}]_i$ in neurons with lower levels of surface $\alpha 7$ -nAChRs does not reach the threshold for cell death. As neurons start making contacts with their targets (at about E9), they start responding to CNTF, which can downregulate surface $\alpha 7$ -nAChRs. At the same time, upregulation of chPSCA reduces the Ca^{2+} influx through $\alpha 7$ -nAChRs. Mature neurons also cluster $\alpha 7$ -nAChR, which restricts Ca^{2+} signaling to specific cellular subdomains. These mechanisms prevent large, global increase in $[\text{Ca}^{2+}]_i$ and stop $\alpha 7$ -nAChR from facilitating cell death.

fewer surface $\alpha 7$ -nAChRs does not reach a threshold for cell death and, therefore, these neurons survive. At E9, neurons start making contacts with their targets and by E14 peripheral synaptogenesis is complete (Landmesser and Pilar, 1978). During this time, chPSCA is upregulated on ciliary ganglion neurons, which leads to the reduction in Ca^{2+} influx via $\alpha 7$ -nAChRs. Furthermore, mature neurons start to express a variety of Ca^{2+} buffers and pumps, which either sequester the intracellular Ca^{2+} or pump it into the ER or out of the cell. The neurons also start responding to the ciliary neurotrophic factor (CNTF) released from their targets, on which they become dependent for survival (Finn and Nishi, 1996; Finn et al., 1998). Previously, CNTF was shown to downregulate surface $\alpha 7$ -nAChRs (Halvorsen and Berg, 1989). It is also possible that CNTF induces chPSCA expression, however this is currently unknown. All of these characteristics ultimately prevent the large, global increases in $[\text{Ca}^{2+}]_i$ in mature ciliary ganglion neurons, which protects them from $\alpha 7$ -nAChR mediated apoptosis later in development after the final numbers of neurons in the ciliary ganglion have been established.

Significance of the results

The proper complement of neurons is critical for the establishment of precise neuronal connections in the developing nervous system. Therefore elucidation of the mechanisms that sculpt the neuronal numbers during development is important for understanding the proper function of the mature nervous system. Most of the evidence in the field of developmental cell death supports the neurotrophic hypothesis, which focuses on the role

of neuron-target interactions and the retrograde control of neuronal survival by target-derived factors (Oppenheim, 1991; Snider, 1994; Davies, 1996). In contrast, the evidence for the role of afferents in regulation of neuronal survival is more limited. Much of the evidence supporting the role of activity in regulating cell death comes from the studies where the afferent input has been removed by nerve transection or blockade of the voltage-gated sodium channels with TTX, resulting in increased cell death in target neuronal populations (Okado and Oppenheim, 1984; Clarke, 1985; Furber et al., 1987). However, with the removal of pro-survival signaling pathways, complete deafferentation also removes the pro-death effects. Therefore, from these studies it is impossible to dissect which ligand-gated channels activate the pro-survival versus pro-death signaling pathways. In contrast, our studies focused on a role of the single ligand-gated ion channel, $\alpha 7$ -nAChR, that has been well studied in the ciliary ganglion and is known to be excluded from the PSDs (Jacob and Berg, 1983; Jacob et al., 1986; Horch and Sargent, 1995). Our observations demonstrate that anterograde factors, such as acetylcholine acting via $\alpha 7$ -nAChRs, can facilitate the cell death of neurons by inducing large increases in $[Ca^{2+}]_i$. These results provide an important contribution to the field of developmental cell death because they demonstrate that neuronal survival can also be regulated independently of neuron-target interactions. These results further indicate that control of developmental cell death is more complex than originally predicted by the neurotrophic hypothesis. Importantly, our data present a mechanism by which classical neurotransmitters can induce and regulate programmed cell death in the developing nervous system.

Although we have used the chicken ciliary ganglion as a model, our findings likely extend beyond the parasympathetic nervous system and may apply to the developing neurons in the sympathetic as well as the central nervous systems. Since sympathetic neurons also express high levels of $\alpha 7$ -nAChRs (Margiotta and Gurantz, 1989; Devay et al., 1994), a similar mechanism by which $\alpha 7$ -nAChRs induce cell death in this system may be applicable; however, this still needs to be determined. In the CNS, the activation of heteromeric nAChRs containing $\beta 2$ subunit on newborn granule cells in the olfactory bulb, a structure that undergoes neurogenesis throughout the adulthood, leads to the apoptosis of these neurons (Mechawar et al., 2004). Furthermore, in the developing retina, glutamate acting through NMDA receptors expressed on the retinal ganglion cells located in inner layer of the retina preferentially induces cell death in this neuronal population (Rocha et al., 1999; Grunder et al., 2000). Altogether, the above evidence indicates that, besides $\alpha 7$ -nAChRs, neurons use other ligand-gated ion channels to regulate cell death during development. This suggests that the control of cell death by the neurotransmitters and the neuromodulators may be the conserved phenomenon utilized by a variety of neuronal populations in the CNS and in the PNS.

Since $\alpha 7$ -nAChRs perform many different traditional and non-traditional roles, they are subjected to a variety of modulatory mechanisms that fine-tune their signaling. These modulatory mechanisms probably involve certain post-translational modifications that alter the conformation of these channels, resulting in changes in the conductance, agonist affinity and desensitization rates. The discovery of endogenous prototoxins, such as

lynx1 and lynx2, indicates that $\alpha 7$ -nAChR signaling can also be modulated locally at the cell surface by directly interacting with these molecules (Miwa et al., 1999; Ibanez-Tallon et al., 2002). Therefore, based on the intrinsic state of activity and the need for nicotinic signaling, neurons can recruit these prototoxins to the cell surface where they alter the biophysical and the pharmacological properties of $\alpha 7$ -nAChRs in a very short time period. We have demonstrated that the neurons in the ciliary ganglion express PSCA, which modulates the function of $\alpha 7$ -nAChRs. The PSCA belongs to the Ly-6/neurotoxin superfamily and, until our studies had demonstrated it, it was not believed to be expressed in the nervous system (Reiter et al., 1998). Furthermore, the upregulation of the PSCA during the period of cell loss in the ciliary ganglion offsets the deleterious effects of $\alpha 7$ -nAChRs, preferentially on choroid neurons, indicating that the endogenous prototoxins play an important role during normal development by modulating the nicotinic signaling. However, the mechanism by which PSCA modulates $\alpha 7$ -nAChRs function still needs to be determined.

The importance of endogenous prototoxins in the normal nervous system is only emerging and the way these molecules modulate the function of nAChRs is likely very complex. Based on the cellular distribution of nAChRs, different members of the Ly-6/neurotoxin superfamily may associate with different nAChRs and modulate nicotinic signaling in a variety of ways. For example, heteromeric nAChRs which are found in the PSDs on ciliary ganglion neurons may associate with completely different prototoxins than extrasynaptically located $\alpha 7$ -nAChRs. We have found three different Ly-

6/neurotoxin members in the ciliary ganglion, however, only PSCA was developmentally regulated. PSCA was shown to block virtually all intracellular increase in Ca^{2+} via $\alpha 7$ -nAChRs, suggesting that it has strong modulatory effects on the $\alpha 7$ -nAChR signaling. The presence of a large number of silent $\alpha 7$ -nAChRs on the surface of ciliary ganglion neurons (Blumenthal et al., 1999; McNerney et al., 2000a) further corroborates these strong modulatory effects of PSCA. Therefore, it is reasonable that other prototoxins expressed in the ciliary ganglion have more subtle effects on nAChRs signaling than PSCA. Since $\alpha 7$ -nAChRs in the ciliary ganglion display heterogeneous conductances (McNerney et al., 2000a; Nai et al., 2003), it is possible that they associate with different prototoxins that modulate their properties in a variety of ways. The neurons may have a sensor that determines the level of signaling via $\alpha 7$ -nAChRs. If the signaling through $\alpha 7$ -nAChRs is too high, neurons upregulate the surface PSCA expression in order to prevent activation of $\alpha 7$ -nAChRs. The neurons with low to moderate levels of $\alpha 7$ -nAChR signaling may present other prototoxins on their surface, only to fine-tune the signaling via $\alpha 7$ -nAChRs. Some nAChRs may not be modulated by prototoxins at all. For example, the presynaptic $\alpha 7$ -nAChRs that regulate the release of ACh from the presynaptic terminals in the ciliary ganglion system display much slower desensitization kinetics than their counterparts on the ciliary ganglion neurons (Zhang et al., 1994). These slower rates of desensitization could be due to a lack of association of the presynaptic $\alpha 7$ -nAChRs with the PSCA or another member of the Ly-6/neurotoxin superfamily rather than the association with the $\beta 2$ subunit. In fact, based on our real-time PCR data, we found much lower levels of PSCA mRNA in the CNS than in the

peripheral ganglia. The discovery of more members of the Ly-6/neurotoxin superfamily and their expression profile in the CNS and in the PNS will be essential for understanding the normal function of $\alpha 7$ -nAChRs in the developing and the mature nervous system.

The $\alpha 7$ -AChRs are expressed very early in development (Smith et al., 1979; Zoli et al., 1995) and their activation has been shown to play an important role in a variety of developmental processes (Role and Berg, 1996a; Broide and Leslie, 1999). Our results propose a mechanism of cell death induction in the developing parasympathetic neurons via the activation of $\alpha 7$ -nAChRs. Therefore, the activation of these receptors at improper times during development, for example, by smoking during pregnancy, can cause a variety of neurodevelopmental disorders due to improper cell migration, formation of circuits and increased cell death. In fact, animals that can self-administer nicotine display increased neuronal cell death in the dentate gyrus (Abrous et al., 2002) and prenatal exposure to nicotine in rats can alter the neuronal cell size and number in the hippocampus and the somatosensory cortex (Roy et al., 1998; Roy et al., 2002).

The $\alpha 7$ -nAChRs have also been implicated in many neurodegenerative disorders (Picciotto and Zoli, 2002); therefore, understanding their signaling and modulation during development can lead to discovery of new therapies for these diseases. For example, β -amyloid can bind to $\alpha 7$ -nAChRs and activate MAPK cascade in the hippocampus, which ultimately leads to dephosphorylation of pro-survival transcription factor CREB (Dineley et al., 2001). These results suggest that over-activation of $\alpha 7$ -nAChRs by the β -amyloid

can cause toxic effects and possibly cell death in the aging brain. Recent experiments show that increased signaling via nAChRs can lead to neurodegeneration in the developing mouse brain lacking the *lynx1* gene (Miwa et al., 1999), supporting our results that the modulation of nAChR function is important for proper development. Therefore, the failure to properly modulate the $\alpha 7$ -nAChR function in the aging brain could lead to overactivation of these receptors, which could be important for the etiology of many neurodegenerative diseases. Genetic screens performed on the brain tissue of patients with Alzheimer's or Parkinson's diseases could reveal whether they carry mutations in the genes coding for the Ly-6/Neurotoxin molecules.

One of the most provocative suggestions presented in this dissertation is that aberrant $\alpha 7$ -nAChR signaling may be associated with certain types of cancers. This is based on the observation that the chPSCA molecule is the ortholog of the mouse PSCA, which is an antigen upregulated in high-grade metastatic prostate tumors (Reiter et al., 1998). The implication that $\alpha 7$ -nAChR signaling is involved in tumorigenesis of non-neural tissue is corroborated by the expression of these channels in keratinocytes, lymphocytes, endothelial cells and glia (Macklin et al., 1998; Benhammou et al., 2000; Zia et al., 2000; Sharma and Vijayaraghavan, 2001; Smit et al., 2001). In fact, $\alpha 7$ -nAChRs control terminal differentiation in keratinocytes (Arredondo et al., 2002), suggesting that perturbations in $\alpha 7$ -nAChR signaling may lead to defects in the cell cycle regulation in these cells. It would be interesting to see whether the endogenous prototoxins are expressed in keratinocytes and other non-neural cells where they modulate the $\alpha 7$ -

nAChR signaling and whether their expression changes in cancer. Since PSCA is only one of the prototoxins that modulate the signaling via $\alpha 7$ -nAChRs, the discovery of more members of the Ly-6/Neurotoxin superfamily may prove fruitful in the treatment of cancers of neural and non-neural origins.

Future Directions

The experiments presented in this dissertation demonstrate that the activation of $\alpha 7$ -nAChRs on ciliary ganglion neurons facilitates cell death. These experiments suggest that large increases in $[Ca^{2+}]_i$ induce cell death of neurons with too many $\alpha 7$ -nAChRs. Although the experiments that can test this directly *in vivo* are not easy to design, the role of Ca^{2+} in $\alpha 7$ -nAChR-mediated cell death could be determined by performing some of the following experiments. First, the developmental expression of specific Ca^{2+} buffers and pumps will have to be assessed between E8 and E14 in chicken embryos. Using the RCASBP(A) retrovirus, buffers such as parvalbumin or pumps such as SERCA can be overexpressed in the ciliary ganglion neurons. If Ca^{2+} is the messenger of $\alpha 7$ -nAChR-mediated cell death, the chronic activation of $\alpha 7$ -nAChRs by the GTS-21, an $\alpha 7$ -nAChR specific agonist, during the period of cell loss in these embryos should result in the diminished cell death of ciliary ganglion neurons as compared to the open RCASBP(A) infected embryos. Also, GTS-21 should exacerbate cell death in embryos in which the endogenous Ca^{2+} buffers or pumps are removed by RNAi. Furthermore, overexpressing the $\alpha 7$ -nAChRs with slow desensitization rates in the ciliary ganglion neurons should

lead to a much larger influx of Ca^{2+} to the neurons and, therefore, increased cell death in the ciliary ganglion.

One of the most interesting results presented here is that the chPSCA molecule inhibits the nicotine-induced increases in $[\text{Ca}^{2+}]_i$ via $\alpha 7$ -nAChRs and prevents the cell death of choroid neurons. However, how the $\alpha 7$ -nAChRs and chPSCA interact is not clear. First, it will have to be determined whether these molecules physically interact with each other or whether there is an intermediate molecule that mediates this interaction. This can be initially assessed in cultured ciliary ganglion neurons overexpressing chPSCA tagged with a V5 epitope tag and determining whether there is a co-localization of $\alpha 7$ -nAChRs with the V5 antibody. Next, we can perform immunoprecipitations using the antibodies against $\alpha 7$ -nAChRs and the V5 and determine whether $\alpha 7$ -nAChRs immunoprecipitate with the V5 antibody. If there is such interaction between $\alpha 7$ -nAChRs and chPSCA, we will need to determine whether chPSCA binds to the same site on $\alpha 7$ -nAChRs as α btx or some other allosteric site. To show this, competition experiments using the labeled α btx can be performed in acutely dissociated ciliary ganglion neurons overexpressing chPSCA. If both molecules bind to the same site on the $\alpha 7$ -nAChRs molecule, adding increasingly higher concentrations of α btx-Alexa 488 to dissociated neurons should displace the bound chPSCA. This could be quantified with the flow cytometry or radioactively.

The molecular signals that lead to the upregulation of chPSCA in the ciliary ganglion during the period of cell loss are unknown. The sharp increase in chPSCA expression during the period of synapse formation suggests that targets regulate the expression of chPSCA in ciliary ganglion neurons. This can be tested *in vitro* by treating the ciliary ganglion neurons with different target-derived molecules. The expression of chPSCA can be quantified by quantitative real-time PCR. Since CNTF effectively downregulates the expression of $\alpha 7$ -nAChRs on the ciliary ganglion neurons (Halvorsen and Berg, 1989), it is a perfect candidate for the regulation of chPSCA expression. Rather than downregulating the expression of $\alpha 7$ -nAChRs, retrograde signaling via the CNTF could lead to the upregulation of chPSCA and the inhibition of $\alpha 7$ -nAChR current. Some other target-derived molecules that could regulate chPSCA expression include activin or follistatin, which are the molecules that regulate expression of somatostatin in ciliary ganglion neurons (Darland et al., 1995; Darland and Nishi, 1998).

In conclusion, in addition to mediating fast excitatory transmission, nAChRs perform a variety of non-traditional roles in the developing nervous system, which are attributed to their high relative Ca^{2+} permeability. Therefore, the precise function of nAChRs combined with fine-tuning in their signaling by a growing number of endogenous prototoxins is important for proper development of the nervous system. Furthermore, it is intriguing that chPSCA is an ortholog of mouse PSCA, an antigen upregulated in prostate cancers, suggesting that nAChRs may be involved in the formation of certain types of tumors, a function previously not associated with nAChRs. These findings

further demonstrate the widespread functions of nAChRs in the nervous system but also in non-neural tissues. Therefore, the elucidation of non-traditional roles of nAChRs will be important for a complete understanding of their function in normal physiology and in disease.

COMPREHENSIVE BIBLIOGRAPHY

Abrous DN, Adriani W, Montaron MF, Aurousseau C, Rougon G, Le Moal M, Piazza PV (2002) Nicotine self-administration impairs hippocampal plasticity. *J Neurosci* 22:3656-3662.

Alkondon M, Pereira EF, Wonnacott S, Albuquerque EX (1992) Blockade of nicotinic currents in hippocampal neurons defines methyllycaconitine as a potent and specific receptor antagonist. *Mol Pharmacol* 41:802-808.

Ameisen JC (1996) The origin of programmed cell death. *Science* 272:1278-1279.

Anand R, Conroy WG, Schoepfer R, Whiting P, Lindstrom J (1991) Neuronal nicotinic acetylcholine receptors expressed in *Xenopus* oocytes have a pentameric quaternary structure. *J Biol Chem* 266:11192-11198.

Arredondo J, Nguyen VT, Chernyavsky AI, Bercovich D, Orr-Urtreger A, Kummer W, Lips K, Vetter DE, Grando SA (2002) Central role of alpha7 nicotinic receptor in differentiation of the stratified squamous epithelium. *J Cell Biol* 159:325-336.

Bansal A, Singer JH, Hwang BJ, Xu W, Beaudet A, Feller MB (2000) Mice lacking specific nicotinic acetylcholine receptor subunits exhibit dramatically altered spontaneous

activity patterns and reveal a limited role for retinal waves in forming ON and OFF circuits in the inner retina. *J Neurosci* 20:7672-7681.

Barde YA, Edgar D, Thoenen H (1982) Purification of a new neurotrophic factor from mammalian brain. *Embo J* 1:549-553.

Benhammou K, Lee M, Strook M, Sullivan B, Logel J, Raschen K, Gotti C, Leonard S (2000) [(3)H]Nicotine binding in peripheral blood cells of smokers is correlated with the number of cigarettes smoked per day. *Neuropharmacology* 39:2818-2829.

Berg DK, Conroy WG (2002) Nicotinic alpha 7 receptors: synaptic options and downstream signaling in neurons. *J Neurobiol* 53:512-523.

Berg DK, Conroy WG, Liu Z, Zago WM (2006) Nicotinic signal transduction machinery. *J Mol Neurosci* 30:149-152.

Berger F, Gage FH, Vijayaraghavan S (1998) Nicotinic receptor-induced apoptotic cell death of hippocampal progenitor cells. *J Neurosci* 18:6871-6881.

Berkemeier LR, Winslow JW, Kaplan DR, Nikolics K, Goeddel DV, Rosenthal A (1991) Neurotrophin-5: a novel neurotrophic factor that activates trk and trkB. *Neuron* 7:857-866.

Berridge MJ, Bootman MD, Roderick HL (2003) Calcium signalling: dynamics, homeostasis and remodelling. *Nat Rev Mol Cell Biol* 4:517-529.

Bertrand D, Bertrand S, Ballivet M (1992) Pharmacological properties of the homomeric alpha 7 receptor. *Neurosci Lett* 146:87-90.

Bertrand D, Galzi JL, Devillers-Thiery A, Bertrand S, Changeux JP (1993) Mutations at two distinct sites within the channel domain M2 alter calcium permeability of neuronal alpha 7 nicotinic receptor. *Proc Natl Acad Sci U S A* 90:6971-6975.

Betz C, Lange G, Pal GP, Wilson KS, Maelicke A, Saenger W (1991) The refined crystal structure of alpha-cobratoxin from *Naja naja siamensis* at 2.4-Å resolution. *J Biol Chem* 266:21530-21536.

Bina KG, Guzman P, Broide RS, Leslie FM, Smith MA, O'Dowd DK (1995) Localization of alpha 7 nicotinic receptor subunit mRNA and alpha-bungarotoxin binding sites in developing mouse somatosensory thalamocortical system. *J Comp Neurol* 363:321-332.

Blumenthal EM, Shoop RD, Berg DK (1999) Developmental changes in the nicotinic responses of ciliary ganglion neurons. *J Neurophysiol* 81:111-120.

Boydston WR, Sohal GS (1979) Grafting of additional periphery reduces embryonic loss of neurons. *Brain Res* 178:403-410.

Broide RS, Leslie FM (1999) The alpha7 nicotinic acetylcholine receptor in neuronal plasticity. *Mol Neurobiol* 20:1-16.

Broide RS, O'Connor LT, Smith MA, Smith JA, Leslie FM (1995) Developmental expression of alpha 7 neuronal nicotinic receptor messenger RNA in rat sensory cortex and thalamus. *Neuroscience* 67:83-94.

Brumwell CL, Johnson JL, Jacob MH (2002) Extrasynaptic alpha 7-nicotinic acetylcholine receptor expression in developing neurons is regulated by inputs, targets, and activity. *J Neurosci* 22:8101-8109.

Bunker GL, Nishi R (2002) Developmental cell death in vivo: rescue of neurons independently of changes at target tissues. *J Comp Neurol* 452:80-92.

Buss RR, Sun W, Oppenheim RW (2006) Adaptive roles of programmed cell death during nervous system development. *Annu Rev Neurosci* 29:1-35.

Carlson NG, Bacchi A, Rogers SW, Gahring LC (1998) Nicotine blocks TNF-alpha-mediated neuroprotection to NMDA by an alpha-bungarotoxin-sensitive pathway. *J Neurobiol* 35:29-36.

Castro NG, Albuquerque EX (1995) alpha-Bungarotoxin-sensitive hippocampal nicotinic receptor channel has a high calcium permeability. *Biophys J* 68:516-524.

Catsicas M, Pequignot Y, Clarke PG (1992) Rapid onset of neuronal death induced by blockade of either axoplasmic transport or action potentials in afferent fibers during brain development. *J Neurosci* 12:4642-4650.

Catsicas S, Thanos S, Clarke PG (1987) Major role for neuronal death during brain development: refinement of topographical connections. *Proc Natl Acad Sci U S A* 84:8165-8168.

Chang KT, Berg DK (1999) Nicotinic acetylcholine receptors containing alpha7 subunits are required for reliable synaptic transmission in situ. *J Neurosci* 19:3701-3710.

Chang KT, Berg DK (2001a) Voltage-gated channels block nicotinic regulation of CREB phosphorylation and gene expression in neurons. *Neuron* 32:855-865.

Chang KT, Berg DK (2001b) Voltage-gated channels block nicotinic regulation of CREB phosphorylation and gene expression in neurons. *Neuron* 32:855-865.

Charpantier E, Barneoud P, Moser P, Besnard F, Sgard F (1998) Nicotinic acetylcholine subunit mRNA expression in dopaminergic neurons of the rat substantia nigra and ventral tegmental area. *Neuroreport* 9:3097-3101.

Chiappinelli VA, Giacobini E (1978) Time course of appearance of alpha-bungarotoxin binding sites during development of chick ciliary ganglion and iris. *Neurochem Res* 3:465-478.

Chimienti F, Hogg RC, Plantard L, Lehmann C, Brakch N, Fischer J, Huber M, Bertrand D, Hohl D (2003) Identification of SLURP-1 as an epidermal neuromodulator explains the clinical phenotype of Mal de Meleda. *Hum Mol Genet* 12:3017-3024.

Choi DW (1994) Glutamate receptors and the induction of excitotoxic neuronal death. *Prog Brain Res* 100:47-51.

Clarke PG (1985) Neuronal death during development in the isthmo-optic nucleus of the chick: sustaining role of afferents from the tectum. *J Comp Neurol* 234:365-379.

Clarke PG, Cowan WM (1975) Ectopic neurons and aberrant connections during neural development. *Proc Natl Acad Sci U S A* 72:4455-4458.

Clarke PG, Cowan WM (1976) The development of the isthmo-optic tract in the chick, with special reference to the occurrence and correction of developmental errors in the location and connections of isthmo-optic neurons. *J Comp Neurol* 167:143-164.

Clarke PG, Posada A, Primi MP, Castagne V (1998) Neuronal death in the central nervous system during development. *Biomed Pharmacother* 52:356-362.

Coggan JS, Paysan J, Conroy WG, Berg DK (1997) Direct recording of nicotinic responses in presynaptic nerve terminals. *J Neurosci* 17:5798-5806.

Cohen-Cory S, Dreyfus CF, Black IB (1991) NGF and excitatory neurotransmitters regulate survival and morphogenesis of cultured cerebellar Purkinje cells. *J Neurosci* 11:462-471.

Collins F, Lile JD (1989) The role of dihydropyridine-sensitive voltage-gated calcium channels in potassium-mediated neuronal survival. *Brain Res* 502:99-108.

Collins F, Schmidt MF, Guthrie PB, Kater SB (1991) Sustained increase in intracellular calcium promotes neuronal survival. *J Neurosci* 11:2582-2587.

Conroy WG, Berg DK (1995) Neurons can maintain multiple classes of nicotinic acetylcholine receptors distinguished by different subunit compositions. *J Biol Chem* 270:4424-4431.

Conroy WG, Berg DK (1998) Nicotinic receptor subtypes in the developing chick brain: appearance of a species containing the alpha4, beta2, and alpha5 gene products. *Mol Pharmacol* 53:392-401.

Conroy WG, Vernallis AB, Berg DK (1992) The alpha 5 gene product assembles with multiple acetylcholine receptor subunits to form distinctive receptor subtypes in brain. *Neuron* 9:679-691.

Conroy WG, Liu Z, Nai Q, Coggan JS, Berg DK (2003) PDZ-containing proteins provide a functional postsynaptic scaffold for nicotinic receptors in neurons. *Neuron* 38:759-771.

Coronas V, Durand M, Chabot JG, Jourdan F, Quirion R (2000) Acetylcholine induces neuritic outgrowth in rat primary olfactory bulb cultures. *Neuroscience* 98:213-219.

Corriveau RA, Berg DK (1993) Coexpression of multiple acetylcholine receptor genes in neurons: quantification of transcripts during development. *J Neurosci* 13:2662-2671.

Coulombe JN, Nishi R (1991) Stimulation of somatostatin expression in developing ciliary ganglion neurons by cells of the choroid layer. *J Neurosci* 11:553-562.

Coulombe JN, Schwall R, Parent AS, Eckenstein FP, Nishi R (1993) Induction of somatostatin immunoreactivity in cultured ciliary ganglion neurons by activin in choroid cell-conditioned medium. *Neuron* 10:899-906.

Couturier S, Bertrand D, Matter JM, Hernandez MC, Bertrand S, Millar N, Valera S, Barkas T, Ballivet M (1990) A neuronal nicotinic acetylcholine receptor subunit (alpha 7)

is developmentally regulated and forms a homo-oligomeric channel blocked by alpha-BTX. *Neuron* 5:847-856.

Cowan WM, Fawcett JW, O'Leary DD, Stanfield BB (1984) Regressive events in neurogenesis. *Science* 225:1258-1265.

Crespo D, O'Leary DD, Cowan WM (1985) Changes in the numbers of optic nerve fibers during late prenatal and postnatal development in the albino rat. *Brain Res* 351:129-134.

Crowley C, Spencer SD, Nishimura MC, Chen KS, Pitts-Meek S, Armanini MP, Ling LH, McMahon SB, Shelton DL, Levinson AD, et al. (1994) Mice lacking nerve growth factor display perinatal loss of sensory and sympathetic neurons yet develop basal forebrain cholinergic neurons. *Cell* 76:1001-1011.

Cuevas J, Berg DK (1998) Mammalian nicotinic receptors with alpha7 subunits that slowly desensitize and rapidly recover from alpha-bungarotoxin blockade. *J Neurosci* 18:10335-10344.

D'Amico-Martel A (1982) Temporal patterns of neurogenesis in avian cranial sensory and autonomic ganglia. *Am J Anat* 163:351-372.

Dahm LM, Landmesser LT (1988) The regulation of intramuscular nerve branching during normal development and following activity blockade. *Dev Biol* 130:621-644.

Dani JA (2001) Overview of nicotinic receptors and their roles in the central nervous system. *Biol Psychiatry* 49:166-174.

Dani JA, Bertrand D (2007) Nicotinic acetylcholine receptors and nicotinic cholinergic mechanisms of the central nervous system. *Annu Rev Pharmacol Toxicol* 47:699-729.

Dani JA, Radcliffe KA, Pidoplichko VI (2000) Variations in desensitization of nicotinic acetylcholine receptors from hippocampus and midbrain dopamine areas. *Eur J Pharmacol* 393:31-38.

Darland DC, Nishi R (1998) Activin A and follistatin influence expression of somatostatin in the ciliary ganglion in vivo. *Dev Biol* 202:293-303.

Darland DC, Link BA, Nishi R (1995) Activin A and follistatin expression in developing targets of ciliary ganglion neurons suggests a role in regulating neurotransmitter phenotype. *Neuron* 15:857-866.

Davies AM (1996) The neurotrophic hypothesis: where does it stand? *Philos Trans R Soc Lond B Biol Sci* 351:389-394.

Davis BM, Lewin GR, Mendell LM, Jones ME, Albers KM (1993) Altered expression of nerve growth factor in the skin of transgenic mice leads to changes in response to mechanical stimuli. *Neuroscience* 56:789-792.

Dessaud E, Salaun D, Gayet O, Chabbert M, deLapeyriere O (2006) Identification of lynx2, a novel member of the ly-6/neurotoxin superfamily, expressed in neuronal subpopulations during mouse development. *Mol Cell Neurosci* 31:232-242.

Devay P, Qu X, Role L (1994) Regulation of nAChR subunit gene expression relative to the development of pre- and postsynaptic projections of embryonic chick sympathetic neurons. *Dev Biol* 162:56-70.

Dineley KT, Westerman M, Bui D, Bell K, Ashe KH, Sweatt JD (2001) Beta-amyloid activates the mitogen-activated protein kinase cascade via hippocampal alpha7 nicotinic acetylcholine receptors: In vitro and in vivo mechanisms related to Alzheimer's disease. *J Neurosci* 21:4125-4133.

Eichler ME, Dubinsky JM, Rich KM (1992) Relationship of intracellular calcium to dependence on nerve growth factor in dorsal root ganglion neurons in cell culture. *J Neurochem* 58:263-269.

Eisen JS, Melancon E (2001) Interactions with identified muscle cells break motoneuron equivalence in embryonic zebrafish. *Nat Neurosci* 4:1065-1070.

Ellis HM, Horvitz HR (1986) Genetic control of programmed cell death in the nematode *C. elegans*. *Cell* 44:817-829.

Epstein ML, Davis JP, Gellman LE, Lamb JR, Dahl JL (1988) Cholinergic neurons of the chicken ciliary ganglion contain somatostatin. *Neuroscience* 25:1053-1060.

Ernfors P, Lee KF, Jaenisch R (1994a) Mice lacking brain-derived neurotrophic factor develop with sensory deficits. *Nature* 368:147-150.

Ernfors P, Lee KF, Kucera J, Jaenisch R (1994b) Lack of neurotrophin-3 leads to deficiencies in the peripheral nervous system and loss of limb proprioceptive afferents. *Cell* 77:503-512.

Ernfors P, Ibanez CF, Ebendal T, Olson L, Persson H (1990) Molecular cloning and neurotrophic activities of a protein with structural similarities to nerve growth factor: developmental and topographical expression in the brain. *Proc Natl Acad Sci U S A* 87:5454-5458.

Fabian-Fine R, Skehel P, Errington ML, Davies HA, Sher E, Stewart MG, Fine A (2001) Ultrastructural distribution of the alpha7 nicotinic acetylcholine receptor subunit in rat hippocampus. *J Neurosci* 21:7993-8003.

Federspiel MJ, Hughes SH (1997) Retroviral gene delivery. *Methods Cell Biol* 52:179-214.

Feller MB, Wellis DP, Stellwagen D, Werblin FS, Shatz CJ (1996) Requirement for cholinergic synaptic transmission in the propagation of spontaneous retinal waves. *Science* 272:1182-1187.

Fiedler EP, Marks MJ, Collins AC (1990) Postnatal development of two nicotinic cholinergic receptors in seven mouse brain regions. *Int J Dev Neurosci* 8:533-540.

Finn TP, Nishi R (1996) Expression of a chicken ciliary neurotrophic factor in targets of ciliary ganglion neurons during and after the cell-death phase. *J Comp Neurol* 366:559-571.

Finn TP, Kim S, Nishi R (1998) Overexpression of ciliary neurotrophic factor in vivo rescues chick ciliary ganglion neurons from cell death. *J Neurobiol* 34:283-293.

Flores CM, Rogers SW, Pabreza LA, Wolfe BB, Kellar KJ (1992) A subtype of nicotinic cholinergic receptor in rat brain is composed of alpha 4 and beta 2 subunits and is up-regulated by chronic nicotine treatment. *Mol Pharmacol* 41:31-37.

Forster I, Bertrand D (1995) Inward rectification of neuronal nicotinic acetylcholine receptors investigated by using the homomeric alpha 7 receptor. *Proc Biol Sci* 260:139-148.

Frazier CJ, Buhler AV, Weiner JL, Dunwiddie TV (1998) Synaptic potentials mediated via alpha-bungarotoxin-sensitive nicotinic acetylcholine receptors in rat hippocampal interneurons. *J Neurosci* 18:8228-8235.

Freedman R, Wetmore C, Stromberg I, Leonard S, Olson L (1993) Alpha-bungarotoxin binding to hippocampal interneurons: immunocytochemical characterization and effects on growth factor expression. *J Neurosci* 13:1965-1975.

Freeman JA (1977) Possible regulatory function of acetylcholine receptor in maintenance of retinotectal synapses. *Nature* 269:218-222.

Furber S, Oppenheim RW, Prevet D (1987) Naturally-occurring neuron death in the ciliary ganglion of the chick embryo following removal of preganglionic input: evidence for the role of afferents in ganglion cell survival. *J Neurosci* 7:1816-1832.

Galli-Resta L, Ensini M, Fusco E, Gravina A, Margheritti B (1993) Afferent spontaneous electrical activity promotes the survival of target cells in the developing retinotectal system of the rat. *J Neurosci* 13:243-250.

Ghosh A, Greenberg ME (1995) Calcium signaling in neurons: molecular mechanisms and cellular consequences. *Science* 268:239-247.

Gotti C, Clementi F (2004) Neuronal nicotinic receptors: from structure to pathology. *Prog Neurobiol* 74:363-396.

Gray DB, Pilar GR, Ford MJ (1989) Opiate and peptide inhibition of transmitter release in parasympathetic nerve terminals. *J Neurosci* 9:1683-1692.

Gray R, Rajan AS, Radcliffe KA, Yakehiro M, Dani JA (1996) Hippocampal synaptic transmission enhanced by low concentrations of nicotine. *Nature* 383:713-716.

Greenberg ME, Ziff EB, Greene LA (1986) Stimulation of neuronal acetylcholine receptors induces rapid gene transcription. *Science* 234:80-83.

Grieshammer U, Lewandoski M, Prevette D, Oppenheim RW, Martin GR (1998) Muscle-specific cell ablation conditional upon Cre-mediated DNA recombination in transgenic mice leads to massive spinal and cranial motoneuron loss. *Dev Biol* 197:234-247.

Grunder T, Kohler K, Kaletta A, Guenther E (2000) The distribution and developmental regulation of NMDA receptor subunit proteins in the outer and inner retina of the rat. *J Neurobiol* 44:333-342.

Gumley TP, McKenzie IF, Sandrin MS (1995) Tissue expression, structure and function of the murine Ly-6 family of molecules. *Immunol Cell Biol* 73:277-296.

Hajnoczky G, Davies E, Madesh M (2003) Calcium signaling and apoptosis. *Biochem Biophys Res Commun* 304:445-454.

Halvorsen SW, Berg DK (1989) Specific down-regulation of the alpha-bungarotoxin binding component on chick autonomic neurons by ciliary neuronotrophic factor. *J Neurosci* 9:3673-3680.

Hamburger V (1958) Regression versus peripheral control of differentiation in motor hypoplasia. *Am J Anat* 102:365-409.

Hamburger V, Yip JW (1984) Reduction of experimentally induced neuronal death in spinal ganglia of the chick embryo by nerve growth factor. *J Neurosci* 4:767-774.

Hamburger V, Hamilton HL (1951) A series of normal stages in the development of the chick embryo. *Dev Dyn* 195:231-272.

Hammond WS, Yntema CL (1958) Origin of ciliary ganglia in the chick. *J Comp Neurol* 110:367-389.

Hanson MG, Landmesser LT (2003) Characterization of the circuits that generate spontaneous episodes of activity in the early embryonic mouse spinal cord. *J Neurosci* 23:587-600.

Hashino E, Johnson EM, Jr., Milbrandt J, Shero M, Salvi RJ, Cohan CS (1999) Multiple actions of neurturin correlate with spatiotemporal patterns of Ret expression in developing chick cranial ganglion neurons. *J Neurosci* 19:8476-8486.

Hashino E, Shero M, Junghans D, Rohrer H, Milbrandt J, Johnson EM, Jr. (2001) GDNF and neurturin are target-derived factors essential for cranial parasympathetic neuron development. *Development* 128:3773-3782.

Hollyday M, Hamburger V (1976) Reduction of the naturally occurring motor neuron loss by enlargement of the periphery. *J Comp Neurol* 170:311-320.

Horch HL, Sargent PB (1995) Perisynaptic surface distribution of multiple classes of nicotinic acetylcholine receptors on neurons in the chicken ciliary ganglion. *J Neurosci* 15:7778-7795.

Horie M, Okutomi K, Taniguchi Y, Ohbuchi Y, Suzuki M, Takahashi E (1998) Isolation and characterization of a new member of the human Ly6 gene family (LY6H). *Genomics* 53:365-368.

Hory-Lee F, Frank E (1995) The nicotinic blocking agents d-tubocurarine and alpha-bungarotoxin save motoneurons from naturally occurring death in the absence of neuromuscular blockade. *J Neurosci* 15:6453-6460.

Ibanez-Tallon I, Miwa JM, Wang HL, Adams NC, Crabtree GW, Sine SM, Heintz N (2002) Novel modulation of neuronal nicotinic acetylcholine receptors by association with the endogenous prototoxin lynx1. *Neuron* 33:893-903.

Ibanez-Tallon I, Wen H, Miwa JM, Xing J, Tekinay AB, Ono F, Brehm P, Heintz N (2004) Tethering naturally occurring peptide toxins for cell-autonomous modulation of ion channels and receptors in vivo. *Neuron* 43:305-311.

Jacob MH, Berg DK (1983) The ultrastructural localization of alpha-bungarotoxin binding sites in relation to synapses on chick ciliary ganglion neurons. *J Neurosci* 3:260-271.

Jacob MH, Lindstrom JM, Berg DK (1986) Surface and intracellular distribution of a putative neuronal nicotinic acetylcholine receptor. *J Cell Biol* 103:205-214.

Johnson EM, Jr., Koike T, Franklin J (1992) A "calcium set-point hypothesis" of neuronal dependence on neurotrophic factor. *Exp Neurol* 115:163-166.

Johnson EM, Jr., Gorin PD, Brandeis LD, Pearson J (1980) Dorsal root ganglion neurons are destroyed by exposure in utero to maternal antibody to nerve growth factor. *Science* 210:916-918.

Jones KR, Reichardt LF (1990) Molecular cloning of a human gene that is a member of the nerve growth factor family. *Proc Natl Acad Sci U S A* 87:8060-8064.

Jones KR, Farinas I, Backus C, Reichardt LF (1994) Targeted disruption of the BDNF gene perturbs brain and sensory neuron development but not motor neuron development. *Cell* 76:989-999.

Karlin A (2002) Emerging structure of the nicotinic acetylcholine receptors. *Nat Rev Neurosci* 3:102-114.

Kawai H, Zago W, Berg DK (2002) Nicotinic alpha 7 receptor clusters on hippocampal GABAergic neurons: regulation by synaptic activity and neurotrophins. *J Neurosci* 22:7903-7912.

Khiroug SS, Harkness PC, Lamb PW, Sudweeks SN, Khiroug L, Millar NS, Yakel JL (2002) Rat nicotinic ACh receptor alpha7 and beta2 subunits co-assemble to form functional heteromeric nicotinic receptor channels. *J Physiol* 540:425-434.

King WM (1990) Nicotinic depolarization of optic nerve terminals augments synaptic transmission. *Brain Res* 527:150-154.

Klein R, Silos-Santiago I, Smeyne RJ, Lira SA, Brambilla R, Bryant S, Zhang L, Snider WD, Barbacid M (1994) Disruption of the neurotrophin-3 receptor gene *trkC* eliminates muscle afferents and results in abnormal movements. *Nature* 368:249-251.

Koike T, Tanaka S (1991) Evidence that nerve growth factor dependence of sympathetic neurons for survival in vitro may be determined by levels of cytoplasmic free Ca^{2+} . *Proc Natl Acad Sci U S A* 88:3892-3896.

Koike T, Martin DP, Johnson EM, Jr. (1989) Role of Ca^{2+} channels in the ability of membrane depolarization to prevent neuronal death induced by trophic-factor deprivation: evidence that levels of internal Ca^{2+} determine nerve growth factor dependence of sympathetic ganglion cells. *Proc Natl Acad Sci U S A* 86:6421-6425.

Kuida K, Zheng TS, Na S, Kuan C, Yang D, Karasuyama H, Rakic P, Flavell RA (1996) Decreased apoptosis in the brain and premature lethality in CPP32-deficient mice. *Nature* 384:368-372.

Lachica EA, Kato BM, Lippe WR, Rubel EW (1998) Glutamatergic and GABAergic agonists increase $[Ca^{2+}]_i$ in avian cochlear nucleus neurons. *J Neurobiol* 37:321-337.

Lamb AH (1980) Motoneurone counts in *Xenopus* frogs reared with one bilaterally-innervated hindlimb. *Nature* 284:347-350.

Lampe PA, Cornbrooks EB, Juhasz A, Johnson EM, Jr., Franklin JL (1995) Suppression of programmed neuronal death by a thapsigargin-induced Ca²⁺ influx. *J Neurobiol* 26:205-212.

Land PW, Lund RD (1979) Development of the rat's uncrossed retinotectal pathway and its relation to plasticity studies. *Science* 205:698-700.

Landmesser L (1992) The relationship of intramuscular nerve branching and synaptogenesis to motoneuron survival. *J Neurobiol* 23:1131-1139.

Landmesser L, Pilar G (1972) The onset and development of transmission in the chick ciliary ganglion. *J Physiol (Lond)* 222:691-713.

Landmesser L, Pilar G (1974a) Synaptic transmission and cell death during normal ganglionic development. *J Physiol* 241:737-749.

Landmesser L, Pilar G (1974b) Synapse formation during embryogenesis in ganglion cells lacking the periphery. *J Physiol* 241:715-736.

Landmesser L, Pilar G (1978) Interactions between neurons and their targets during in vivo synaptogenesis. *Fed Proc* 37:2016-2022.

Landmesser LT, Szente M (1986) Activation patterns of embryonic chick hind-limb muscles following blockade of activity and motoneurone cell death. *J Physiol* 380:157-174.

Lapchak PA, Araujo DM, Quirion R, Collier B (1989) Presynaptic cholinergic mechanisms in the rat cerebellum: evidence for nicotinic, but not muscarinic autoreceptors. *J Neurochem* 53:1843-1851.

Laudenbach V, Medja F, Zoli M, Rossi FM, Evrard P, Changeux JP, Gressens P (2002) Selective activation of central subtypes of the nicotinic acetylcholine receptor has opposite effects on neonatal excitotoxic brain injuries. *Faseb J* 16:423-425.

Lee VM (2001) Regulation of neuronal cell number in the developing ciliary ganglion. In: *Cell and Developmental Biology*, p 137. Portland: Oregon Health Sciences University.

Lee VM, Smiley GG, Nishi R (2001) Cell death and neuronal replacement during formation of the avian ciliary ganglion. *Dev Biol* 233:437-448.

Lena C, Changeux JP (1998) Allosteric nicotinic receptors, human pathologies. *J Physiol Paris* 92:63-74.

Lena C, Changeux JP, Mulle C (1993) Evidence for "preterminal" nicotinic receptors on GABAergic axons in the rat interpeduncular nucleus. *J Neurosci* 13:2680-2688.

Leung DW, Parent AS, Cachianes G, Esch F, Coulombe JN, Nikolics K, Eckenstein FP, Nishi R (1992) Cloning, expression during development, and evidence for release of a trophic factor for ciliary ganglion neurons. *Neuron* 8:1045-1053.

Levi-Montalcini R, Angeletti PU (1968) Nerve growth factor. *Physiol Rev* 48:534-569.

Levy RB, Aoki C (2002) Alpha7 nicotinic acetylcholine receptors occur at postsynaptic densities of AMPA receptor-positive and -negative excitatory synapses in rat sensory cortex. *J Neurosci* 22:5001-5015.

Linden R (1994) The survival of developing neurons: a review of afferent control. *Neuroscience* 58:671-682.

Lipton SA (1986) Blockade of electrical activity promotes the death of mammalian retinal ganglion cells in culture. *Proc Natl Acad Sci U S A* 83:9774-9778.

Listerud M, Brussaard AB, Devay P, Colman DR, Role LW (1991) Functional contribution of neuronal AChR subunits revealed by antisense oligonucleotides. *Science* 254:1518-1521.

Liu Z, Neff RA, Berg DK (2006) Sequential interplay of nicotinic and GABAergic signaling guides neuronal development. *Science* 314:1610-1613.

Macklin KD, Maus AD, Pereira EF, Albuquerque EX, Conti-Fine BM (1998) Human vascular endothelial cells express functional nicotinic acetylcholine receptors. *J Pharmacol Exp Ther* 287:435-439.

Maderdrut JL, Oppenheim RW, Prevet D (1988) Enhancement of naturally occurring cell death in the sympathetic and parasympathetic ganglia of the chicken embryo following blockade of ganglionic transmission. *Brain Res* 444:189-194.

Margiotta JF, Gurantz D (1989) Changes in the number, function, and regulation of nicotinic acetylcholine receptors during neuronal development. *Dev Biol* 135:326-339.

Marusich MF, Weston JA (1992) Identification of early neurogenic cells in the neural crest lineage. *Dev Biol* 149:295-306.

Marwitt R, Pilar G, Weakly JN (1971) Characterization of two ganglion cell populations in avian ciliary ganglia. *Brain Res* 25:317-334.

McGehee DS, Role LW (1995) Physiological diversity of nicotinic acetylcholine receptors expressed by vertebrate neurons. *Annu Rev Physiol* 57:521-546.

McGehee DS, Heath MJ, Gelber S, Devay P, Role LW (1995) Nicotine enhancement of fast excitatory synaptic transmission in CNS by presynaptic receptors. *Science* 269:1692-1696.

McLoon SC, Lund RD (1982) Transient retinofugal pathways in the developing chick. *Exp Brain Res* 45:277-284.

McNerney ME, Pardi D, Pugh PC, Nai Q, Margiotta JF (2000) Expression and channel properties of alpha-bungarotoxin-sensitive acetylcholine receptors on chick ciliary and choroid neurons. *J Neurophysiol* 84:1314-1329.

Mechawar N, Saghatelian A, Grailhe R, Scoriels L, Gheusi G, Gabellec MM, Lledo PM, Changeux JP (2004) Nicotinic receptors regulate the survival of newborn neurons in the adult olfactory bulb. *Proc Natl Acad Sci U S A* 101:9822-9826.

Mennerick S, Zorumski CF (2000) Neural activity and survival in the developing nervous system. *Mol Neurobiol* 22:41-54.

Meriney SD, Pilar G (1987) Cholinergic innervation of the smooth muscle cells in the choroid coat of the chick eye and its development. *J Neurosci* 7:3827-3839.

Meriney SD, Pilar G, Ogawa M, Nunez R (1987) Differential neuronal survival in the avian ciliary ganglion after chronic acetylcholine receptor blockade. *J Neurosci* 7:3840-3849.

Miwa JM, Ibanez-Tallon I, Crabtree GW, Sanchez R, Sali A, Role LW, Heintz N (1999) lynx1, an endogenous toxin-like modulator of nicotinic acetylcholine receptors in the mammalian CNS. *Neuron* 23:105-114.

Miwa JM, Stevens TR, King SL, Caldarone BJ, Ibanez-Tallon I, Xiao C, Fitzsimonds RM, Pavlides C, Lester HA, Picciotto MR, Heintz N (2006) The prototoxin lynx1 acts on nicotinic acetylcholine receptors to balance neuronal activity and survival in vivo. *Neuron* 51:587-600.

Momose-Sato Y, Mochida H, Sasaki S, Sato K (2003) Depolarization waves in the embryonic CNS triggered by multiple sensory inputs and spontaneous activity: optical imaging with a voltage-sensitive dye. *Neuroscience* 116:407-423.

Morgan BA, Fekete DM (1996) Manipulating gene expression with replication-competent retroviruses. *Methods Cell Biol* 51:185-218.

Nai Q, McIntosh JM, Margiotta JF (2003) Relating neuronal nicotinic acetylcholine receptor subtypes defined by subunit composition and channel function. *Mol Pharmacol* 63:311-324.

Narayanan CH, Narayanan Y (1978a) On the origin of the ciliary ganglion in birds studied by the method of interspecific transplantation of embryonic brain regions between quail and chick. *J Embryol Exp Morphol* 47:137-148.

Narayanan CH, Narayanan Y (1978b) Neuronal adjustments in developing nuclear centers of the chick embryo following transplantation of an additional optic primordium. *J Embryol Exp Morphol* 44:53-70.

Nishi R (1996) Autonomic and sensory neuron cultures. *Methods Cell Biol* 51:249-263.

Nishi R, Berg DK (1977) Dissociated ciliary ganglion neurons in vitro: survival and synapse formation. *Proc Natl Acad Sci U S A* 74:5171-5175.

Nishi R, Berg DK (1979) Survival and development of ciliary ganglion neurones grown alone in cell culture. *Nature* 277:232-234.

Nishi R, Berg DK (1981) Two components from eye tissue that differentially stimulate the growth and development of ciliary ganglion neurons in cell culture. *J Neurosci* 1:505-513.

O'Leary DD, Cowan WM (1982) Further studies on the development of the isthmo-optic nucleus with special reference to the occurrence and fate of ectopic and ipsilaterally projecting neurons. *J Comp Neurol* 212:399-416.

O'Leary DD, Cowan WM (1984) Survival of isthmo-optic neurons after early removal of one eye. *Brain Res* 314:293-310.

O'Leary DD, Fawcett JW, Cowan WM (1986) Topographic targeting errors in the retinocollicular projection and their elimination by selective ganglion cell death. *J Neurosci* 6:3692-3705.

O'Leary DM, Gerfen CR, Cowan WM (1983) The development and restriction of the ipsilateral retinofugal projection in the chick. *Brain Res* 312:93-109.

Okado N, Oppenheim RW (1984) Cell death of motoneurons in the chick embryo spinal cord. IX. The loss of motoneurons following removal of afferent inputs. *J Neurosci* 4:1639-1652.

Oppenheim RW (1989) The neurotrophic theory and naturally occurring motoneuron death. *Trends Neurosci* 12:252-255.

Oppenheim RW (1991) Cell death during development of the nervous system. *Annu Rev Neurosci* 14:453-501.

Oppenheim RW, Chu-Wang IW, Maderdrut JL (1978) Cell death of motoneurons in the chick embryo spinal cord. III. The differentiation of motoneurons prior to their induced degeneration following limb-bud removal. *J Comp Neurol* 177:87-111.

Oppenheim RW, Prevet D, D'Costa A, Wang S, Houenou LJ, McIntosh JM (2000) Reduction of neuromuscular activity is required for the rescue of motoneurons from naturally occurring cell death by nicotinic-blocking agents. *J Neurosci* 20:6117-6124.

Orr-Urtreger A, Broide RS, Kasten MR, Dang H, Dani JA, Beaudet AL, Patrick JW (2000) Mice homozygous for the L250T mutation in the alpha7 nicotinic acetylcholine receptor show increased neuronal apoptosis and die within 1 day of birth. *J Neurochem* 74:2154-2166.

Pettmann B, Henderson CE (1998) Neuronal cell death. *Neuron* 20:633-647.

Picciotto MR, Zoli M (2002) Nicotinic receptors in aging and dementia. *J Neurobiol* 53:641-655.

Pilar G, Gray DB, Meriney SD (1996) Membrane delimited and intracellular soluble pathways in the somatostatin modulation of ACh release. *Life Sci* 58:1979-1986.

Pilar G, Nunez R, McLennan IS, Meriney SD (1987) Muscarinic and nicotinic synaptic activation of the developing chicken iris. *J Neurosci* 7:3813-3826.

Pittman R, Oppenheim RW (1978) Neuromuscular blockade increases motoneurone survival during normal cell death in the chick embryo. *Nature* 271:364-366.

Pittman R, Oppenheim RW (1979) Cell death of motoneurons in the chick embryo spinal cord. IV. Evidence that a functional neuromuscular interaction is involved in the regulation of naturally occurring cell death and the stabilization of synapses. *J Comp Neurol* 187:425-446.

Potts WM, Olsen M, Boettiger D, Vogt VM (1987) Epitope mapping of monoclonal antibodies to gag protein p19 of avian sarcoma and leukaemia viruses. *J Gen Virol* 68 (Pt 12):3177-3182.

Pugh PC, Berg DK (1994) Neuronal acetylcholine receptors that bind alpha-bungarotoxin mediate neurite retraction in a calcium-dependent manner. *J Neurosci* 14:889-896.

Pugh PC, Margiotta JF (2000) Nicotinic acetylcholine receptor agonists promote survival and reduce apoptosis of chick ciliary ganglion neurons. *Mol Cell Neurosci* 15:113-122.

Purves D (1980) Neuronal competition. *Nature* 287:585-586.

Quik M, Chan J, Patrick J (1994) alpha-Bungarotoxin blocks the nicotinic receptor mediated increase in cell number in a neuroendocrine cell line. *Brain Res* 655:161-167.

Reiter RE, Gu Z, Watabe T, Thomas G, Szigeti K, Davis E, Wahl M, Nisitani S, Yamashiro J, Le Beau MM, Loda M, Witte ON (1998) Prostate stem cell antigen: a cell

surface marker overexpressed in prostate cancer. *Proc Natl Acad Sci U S A* 95:1735-1740.

Rezvani AH, Levin ED (2001) Cognitive effects of nicotine. *Biol Psychiatry* 49:258-267.

Riethmacher D, Sonnenberg-Riethmacher E, Brinkmann V, Yamaai T, Lewin GR, Birchmeier C (1997) Severe neuropathies in mice with targeted mutations in the ErbB3 receptor. *Nature* 389:725-730.

Rizzuto R, Pinton P, Ferrari D, Chami M, Szabadkai G, Magalhaes PJ, Di Virgilio F, Pozzan T (2003) Calcium and apoptosis: facts and hypotheses. *Oncogene* 22:8619-8627.

Rocha M, Martins RA, Linden R (1999) Activation of NMDA receptors protects against glutamate neurotoxicity in the retina: evidence for the involvement of neurotrophins. *Brain Res* 827:79-92.

Rogers M, Dani JA (1995) Comparison of quantitative calcium flux through NMDA, ATP, and ACh receptor channels. *Biophys J* 68:501-506.

Rogers M, Sargent PB (2003) Rapid activation of presynaptic nicotinic acetylcholine receptors by nerve-released transmitter. *Eur J Neurosci* 18:2946-2956.

Rohrer H, Thoenen H (1987) Relationship between differentiation and terminal mitosis: chick sensory and ciliary neurons differentiate after terminal mitosis of precursor cells, whereas sympathetic neurons continue to divide after differentiation. *J Neurosci* 7:3739-3748.

Rohrer H, Henke-Fahle S, el-Sharkawy T, Lux HD, Thoenen H (1985) Progenitor cells from embryonic chick dorsal root ganglia differentiate in vitro to neurons: biochemical and electrophysiological evidence. *Embo J* 4:1709-1714.

Role LW, Berg DK (1996a) Nicotinic receptors in the development and modulation of CNS synapses. *Neuron* 16:1077-1085.

Role LW, Berg DK (1996b) Nicotinic receptors in the development and modulation of CNS synapses. *Neuron* 16:1077-1085.

Roy TS, Seidler FJ, Slotkin TA (2002) Prenatal nicotine exposure evokes alterations of cell structure in hippocampus and somatosensory cortex. *J Pharmacol Exp Ther* 300:124-133.

Roy TS, Andrews JE, Seidler FJ, Slotkin TA (1998) Nicotine evokes cell death in embryonic rat brain during neurulation. *J Pharmacol Exp Ther* 287:1136-1144.

Rubel EW, Hyson RL, Durham D (1990) Afferent regulation of neurons in the brain stem auditory system. *J Neurobiol* 21:169-196.

Ruit KG, Elliott JL, Osborne PA, Yan Q, Snider WD (1992) Selective dependence of mammalian dorsal root ganglion neurons on nerve growth factor during embryonic development. *Neuron* 8:573-587.

Sargent PB (1993) The diversity of neuronal nicotinic acetylcholine receptors. *Annu Rev Neurosci* 16:403-443.

Sato K, Momose-Sato Y (2003) Optical detection of developmental origin of synaptic function in the embryonic chick vestibulocochlear nuclei. *J Neurophysiol* 89:3215-3224.

Schoepfer R, Conroy WG, Whiting P, Gore M, Lindstrom J (1990) Brain alpha-bungarotoxin binding protein cDNAs and MAbs reveal subtypes of this branch of the ligand-gated ion channel gene superfamily. *Neuron* 5:35-48.

Sechrist JW, Wolf J, Bronner-Fraser M (1998) Age-dependent neurotransmitter plasticity of ciliary ganglion neurons. *Mol Cell Neurosci* 12:311-323.

Sharma G, Vijayaraghavan S (2001) Nicotinic cholinergic signaling in hippocampal astrocytes involves calcium-induced calcium release from intracellular stores. *Proc Natl Acad Sci U S A* 98:4148-4153.

Sharma G, Vijayaraghavan S (2002) Nicotinic receptor signaling in nonexcitable cells. *J Neurobiol* 53:524-534.

Shoop R, Chang K, Ellisman M, Berg D (2001a) Synaptically driven calcium transients via nicotinic receptors on somatic spines. *J Neurosci* 21:771-781.

Shoop RD, Chang KT, Ellisman MH, Berg DK (2001b) Synaptically driven calcium transients via nicotinic receptors on somatic spines. *J Neurosci* 21:771-781.

Shoop RD, Martone ME, Yamada N, Ellisman MH, Berg DK (1999a) Neuronal acetylcholine receptors with alpha7 subunits are concentrated on somatic spines for synaptic signaling in embryonic chick ciliary ganglia. *J Neurosci* 19:692-704.

Shoop RD, Martone ME, Yamada N, Ellisman MH, Berg DK (1999b) Neuronal acetylcholine receptors with alpha7 subunits are concentrated on somatic spines for synaptic signaling in embryonic chick ciliary ganglia. *J Neurosci* 19:692-704.

Shoop RD, Esquenazi E, Yamada N, Ellisman MH, Berg DK (2002) Ultrastructure of a somatic spine mat for nicotinic signaling in neurons. *J Neurosci* 22:748-756.

Smeyne RJ, Klein R, Schnapp A, Long LK, Bryant S, Lewin A, Lira SA, Barbacid M (1994) Severe sensory and sympathetic neuropathies in mice carrying a disrupted *Trk/NGF* receptor gene. *Nature* 368:246-249.

Smit AB, Syed NI, Schaap D, van Minnen J, Klumperman J, Kits KS, Lodder H, van der Schors RC, van Elk R, Sorgedrager B, Brejc K, Sixma TK, Geraerts WP (2001) A glia-derived acetylcholine-binding protein that modulates synaptic transmission. *Nature* 411:261-268.

Smith J, Fauquet M, Ziller C, Le Douarin NM (1979) Acetylcholine synthesis by mesencephalic neural crest cells in the process of migration in vivo. *Nature* 282:853-855.

Snider WD (1994) Functions of the neurotrophins during nervous system development: what the knockouts are teaching us. *Cell* 77:627-638.

Sorenson EM, Shiroyama T, Kitai ST (1998) Postsynaptic nicotinic receptors on dopaminergic neurons in the substantia nigra pars compacta of the rat. *Neuroscience* 87:659-673.

Sperry DG, Grobstein P (1985) Regulation of neuron numbers in *Xenopus laevis*: effects of hormonal manipulation altering size at metamorphosis. *J Comp Neurol* 232:287-298.

Summers KL, Giacobini E (1995) Effects of local and repeated systemic administration of (-)nicotine on extracellular levels of acetylcholine, norepinephrine, dopamine, and serotonin in rat cortex. *Neurochem Res* 20:753-759.

Tanaka H, Landmesser LT (1986) Cell death of lumbosacral motoneurons in chick, quail, and chick-quail chimera embryos: a test of the quantitative matching hypothesis of neuronal cell death. *J Neurosci* 6:2889-2899.

Thanos S, Bonhoeffer F (1984) Development of the transient ipsilateral retinotectal projection in the chick embryo: a numerical fluorescence-microscopic analysis. *J Comp Neurol* 224:407-414.

Treinin M, Chalfie M (1995) A mutated acetylcholine receptor subunit causes neuronal degeneration in *C. elegans*. *Neuron* 14:871-877.

Tsetlin V (1999) Snake venom alpha-neurotoxins and other 'three-finger' proteins. *Eur J Biochem* 264:281-286.

Ullian EM, McIntosh JM, Sargent PB (1997) Rapid synaptic transmission in the avian ciliary ganglion is mediated by two distinct classes of nicotinic receptors. *J Neurosci* 17:7210-7219.

Usiak MF, Landmesser LT (1999) Neuromuscular activity blockade induced by muscimol and d-tubocurarine differentially affects the survival of embryonic chick motoneurons. *J Neurosci* 19:7925-7939.

Vernallis AB, Conroy WG, Berg DK (1993) Neurons assemble acetylcholine receptors with as many as three kinds of subunits while maintaining subunit segregation among receptor subtypes. *Neuron* 10:451-464.

Vidal C, Changeux JP (1989) Pharmacological profile of nicotinic acetylcholine receptors in the rat prefrontal cortex: an electrophysiological study in a slice preparation. *Neuroscience* 29:261-270.

Vijayaraghavan S, Huang B, Blumenthal EM, Berg DK (1995) Arachidonic acid as a possible negative feedback inhibitor of nicotinic acetylcholine receptors on neurons. *J Neurosci* 15:3679-3687.

Wada E, Wada K, Boulter J, Deneris E, Heinemann S, Patrick J, Swanson LW (1989) Distribution of alpha 2, alpha 3, alpha 4, and beta 2 neuronal nicotinic receptor subunit mRNAs in the central nervous system: a hybridization histochemical study in the rat. *J Comp Neurol* 284:314-335.

Wang GK, Schmidt J (1976) Receptors for alpha-bungarotoxin in the developing visual system of the chick. *Brain Res* 114:524-529.

Wang L, Galehouse D, Mellon P, Duesberg P, Mason WS, Vogt PK (1976) Mapping oligonucleotides of Rous sarcoma virus RNA that segregate with polymerase and group-specific antigen markers in recombinants. *Proc Natl Acad Sci U S A* 73:3952-3956.

Wooltorton JR, Pidoplichko VI, Broide RS, Dani JA (2003) Differential desensitization and distribution of nicotinic acetylcholine receptor subtypes in midbrain dopamine areas. *J Neurosci* 23:3176-3185.

Wright L (1981a) Cell survival in chick embryo ciliary ganglion is reduced by chronic ganglionic blockade. *Brain Res* 227:283-286.

Wright L (1981b) Cell survival in chick embryo ciliary ganglion is reduced by chronic ganglionic blockade. *Brain Res* 227:283-286.

Yu CR, Role LW (1998) Functional contribution of the alpha7 subunit to multiple subtypes of nicotinic receptors in embryonic chick sympathetic neurones. *J Physiol* 509 (Pt 3):651-665.

Zago WM, Massey KA, Berg DK (2006) Nicotinic activity stabilizes convergence of nicotinic and GABAergic synapses on filopodia of hippocampal interneurons. *Mol Cell Neurosci* 31:549-559.

Zhang ZW, Vijayaraghavan S, Berg DK (1994) Neuronal acetylcholine receptors that bind alpha-bungarotoxin with high affinity function as ligand-gated ion channels. *Neuron* 12:167-177.

Zhang ZW, Coggan JS, Berg DK (1996) Synaptic currents generated by neuronal acetylcholine receptors sensitive to alpha-bungarotoxin. *Neuron* 17:1231-1240.

Zheng JQ, Felder M, Connor JA, Poo MM (1994) Turning of nerve growth cones induced by neurotransmitters. *Nature* 368:140-144.

Zia S, Ndoye A, Lee TX, Webber RJ, Grando SA (2000) Receptor-mediated inhibition of keratinocyte migration by nicotine involves modulations of calcium influx and intracellular concentration. *J Pharmacol Exp Ther* 293:973-981.

Zoli M, Le Novere N, Hill JA, Jr., Changeux JP (1995) Developmental regulation of nicotinic ACh receptor subunit mRNAs in the rat central and peripheral nervous systems. *J Neurosci* 15:1912-1939.

Zoli M, Lena C, Picciotto MR, Changeux JP (1998) Identification of four classes of brain nicotinic receptors using beta2 mutant mice. *J Neurosci* 18:4461-4472.

Zorumski CF, Olney JW (1993) Excitotoxic neuronal damage and neuropsychiatric disorders. *Pharmacol Ther* 59:145-162.