

RESEARCH PUBLICATION No. 52

Preliminary Evaluation of an Acoustic Technique for Mapping Tropical Seagrass Habitats

W.J. Lee Long, C.A. Roder and L.J. McKenzie

Seagrass Ecology Group
Northern Fisheries Centre
Queensland Department of Primary Industries

A.J. Hundley

Offshore Scientific Pty Ltd



A REPORT TO THE GREAT BARRIER REEF MARINE PARK AUTHORITY

© Great Barrier Reef Marine Park Authority 1998

ISSN 1037-1508

ISBN 0 642 23048 X

Published June 1998

by the Great Barrier Reef Marine Park Authority

The opinions expressed in this document are not necessarily those of the Great Barrier Reef Marine Park Authority. Accuracy in calculations, figures, tables, names, quotations, references etc. is the complete responsibility of the authors.

Information contained in this publication is provided as general advice only. For application to specific circumstances, professional advice should be sought.

The Department of Primary Industries, Queensland has taken all reasonable steps to ensure the information contained in this publication is accurate at the time of publication.

Technical enquiries should be directed to: Warren Lee Long, Northern Fisheries Centre, PO Box 5396, Cairns Qld 4870 Australia

The correct citation of this report is:

Lee Long, W.J., Hundley, A.J., Roder, C.A. and McKenzie, L.J. 1998. *Preliminary Evaluation of an Acoustic Technique for Mapping Tropical Seagrass Habitats*. Research Publication No. 52, Great Barrier Reef Marine Park Authority, Townsville.

Cover: Photographs supplied courtesy of the Queensland Department of Primary Industries.

National Library of Australia Cataloguing-in-Publication data:

Preliminary evaluation of an acoustic technique for mapping tropical seagrass habitats.

Bibliography.

ISBN 0 642 23048 X.

1. Seagrasses - Habitat - Remote sensing. I. Lee Long, W. J. II. Great Barrier Reef Marine Park Authority (Australia). (Series : Research publication (Great Barrier Reef Marine Park Authority (Australia)) ; no. 52).

578.76940287



GREAT BARRIER REEF

MARINE PARK AUTHORITY

PO Box 1379

Townsville Qld 4810

Telephone (07) 4750 0700

Executive Summary

1. Our preliminary trials show that acoustic techniques can be used for mapping some types of tropical seagrass habitats. They cannot be used for determining above-ground seagrass biomass in these habitats.
2. The remote acoustic sensing technique can potentially minimise total in-water time and associated safety risks for divers in areas where dangerous marine animals and other obstacles are common.
3. Boundaries of seagrass meadows can be successfully mapped using a fan beam system, combined with ground-truth information. In these trials 13 percent of low-density ($<5\text{g.m}^2$) seagrass sites were not interpreted as seagrass with the acoustic technique. Meadow boundaries interpreted from fan beam data are at a higher resolution than is possible from dive-based surveys.
4. Refinement of the conical beam technique is also required before it is possible to discern low-biomass seagrass habitat from bare substrate. We recommend that modifications be made to reduce transducer instability, ensure the use of real-time dGPS systems and reliable satellite data capture, and to measure the effects of seagrass species, sediment type and bottom topography on acoustic signal strength.
5. Acoustic techniques can provide sediment mapping information at spatial resolutions better than normally available from traditional sediment grab mapping methods. Acoustic data can be used in some situations as a proxy for percent mud - a useful sediment parameter in marine ecology studies.
6. Acoustic data show stronger statistical relationships with some parameters of sediment composition (eg., percent coarse sand, and weighted average of sediment grain size), but cannot be used to describe details of sediment grain-size composition (eg., range, variance and distribution).
7. Acoustic signals provide a measure of changes in benthic parameters, but in tropical seagrasses calibration to absolute biomass measures has limited potential. Some form of calibration is usually necessary in every survey event to interpret graphs and images created with the acoustic technique. The frequency and intensity of ground-truth sampling to calibrate and interpret acoustic data will depend on the spatial scales at which parameters change and can be minimised once an area is initially mapped.
8. Advantages of the acoustic techniques for habitat mapping may be greatest where the scales of variation in seagrass species, sediment type and bottom topography are known and calibration sampling can be minimised. Acoustic data also has a higher spatial resolution than dive-based survey data.
9. Dive-based sampling will always be required in combination with acoustic surveys of seagrass habitat to a) interpret the acoustic signal, and b) collect information on species composition and faunal use (eg., dugong feeding trails) of seagrass habitats.

Table of Contents

| | |
|--|------------|
| EXECUTIVE SUMMARY | III |
| 1. INTRODUCTION & BACKGROUND..... | 1 |
| 1.1 Surveying techniques used in tropical seagrass habitats | 1 |
| 1.2 Acoustic techniques | 2 |
| 1.3 Objectives..... | 2 |
| 2. METHODS..... | 2 |
| 2.1 Site details..... | 2 |
| 2.2 Experimental design..... | 3 |
| 2.3 Acoustic surveying | 3 |
| 2.3.1 <i>Mapping seagrass habitat edges</i> | 4 |
| 2.3.2 <i>Seagrass biomass</i> | 4 |
| 2.3.3 <i>Sediment type</i> | 4 |
| 2.4 Dive-based Surveying | 4 |
| 2.4.1 <i>Mapping Seagrass Habitat Edges</i> | 4 |
| 2.4.2 <i>Seagrass Biomass</i> | 5 |
| 2.4.3 <i>Sediment Type</i> | 5 |
| 2.5 Comparison of methods..... | 5 |
| 2.5.1 <i>Mapping Seagrass Habitat Edges</i> | 5 |
| 2.5.2 <i>Estimating Seagrass Biomass</i> | 5 |
| 2.5.3. <i>Sediment type</i> | 5 |
| 3. RESULTS..... | 9 |
| 3.1 Mapping seagrass habitat edges | 9 |
| 3.1.1. <i>Fan beam mapping using a transducer on a “towfish”</i> | 9 |
| 3.1.2. <i>Fan beam mapping using a fixed transducer</i> | 9 |
| 3.2 Estimating seagrass biomass | 9 |
| 3.2.1. <i>Finescale (sites with 10 m radius)</i> | 10 |
| 3.2.2. <i>Broadscale (regions >1 hectare)</i> | 10 |
| 3.3 Describing sediment type | 16 |
| 4. DISCUSSION..... | 19 |
| 4.1 Mapping seagrass meadow edges | 19 |
| 4.2 Seagrass biomass..... | 20 |
| 4.3 Other seagrass mapping information..... | 21 |
| 4.4 Sediment mapping | 21 |
| 4.5 Efficiencies of survey methods | 22 |
| 5. CONCLUSIONS AND RECOMMENDATIONS..... | 23 |
| 6. REFERENCES..... | 25 |
| APPENDIX 1. DETAILS OF THE ACOUSTIC TECHNIQUE..... | 27 |

List of Figures and Tables

| | | |
|-------------------|--|----|
| Figure 1. | Survey areas in Cairns Harbour used to evaluate acoustic techniques for surveying seagrasses and sediments..... | 7 |
| Figure 2. | Equipment used in acoustic survey of benthic environments: a) configuration of fan beam transducer when deployed from survey vessel and b) hardware of acoustic systems..... | 8 |
| Figure 3. | Acoustic map of Esplanade seagrass habitat, May 1996. Overlay with ground-truthed (diver) sites with seagrass above-ground seagrass biomass (May 1996) and meadow boundaries (December 1993)..... | 11 |
| Figure 4. | Acoustic map of Ellie Point seagrass habitat, May 1996. Overlay with ground-truthed (diver) sites with seagrass above-ground seagrass biomass..... | 12 |
| Figure 5. | Acoustic map of Bessie Point seagrass habitat, May 1996. Overlay with ground-truthed (diver) sites with seagrass above-ground seagrass biomass (May 1996) and meadow boundaries (December 1993)..... | 13 |
| Figure 6. | Sites in each survey area at which above-ground seagrass biomass was ground-truthed by divers and examined using acoustic conical beam..... | 14 |
| Figure 7. | Mean acoustic intensity (decibels) and ground-truthed biomass (g DW m^{-2}) at each site examined at each survey area in Cairns Harbour..... | 15 |
| Figure 8. | Acoustic response measured in decibels and mean sediment grain-size along survey transect at Bessie Point..... | 17 |
| Figure 9. | Acoustic response measured in decibels and mean sediment grain-size along survey transect at Ellie Point..... | 17 |
| Figure 10. | Comparison of acoustic intensity and ground-truthed sediment composition for each sediment sampling site at Bessie Point..... | 18 |
| Table 1. | Seagrass species, ground-truthed mean above ground biomass and the number of sites examined by both acoustic technique and divers at each survey area in Cairns Harbour..... | 9 |
| Table 2. | Results of correlation and regression analysis between acoustic data (decibels) and above-ground seagrass biomass (g DW m^{-2}) at each survey area using conical beam (grazing angle 10°)..... | 10 |
| Table 3. | Results of two-sample T-tests analysis between regions within each survey area for acoustic (decibels) and diver (g DW m^{-2}) methods..... | 10 |
| Table 4. | Results of correlation and regression analysis between acoustic data (decibels) and sediment grain size at Bessie Point using multiple reflection technique (conical beam grazing angle 90°)..... | 16 |
| Table 5. | Results of correlation and regression analysis between acoustic data (decibels) and sediment grain size at Ellie Point using backscatter technique (conical beam grazing angle 45°)..... | 16 |

1. INTRODUCTION & BACKGROUND

Seagrass meadows in Queensland are important nursery habitat for commercial species of penaeid prawns and fish (Coles and Lee Long 1985; Coles *et al.* 1993; Watson *et al.* 1993). Seagrasses are essential food for dugong, *Dugong dugon* (Miller), and green sea turtles, *Chelonia mydas* (Linnaeus) (Lanyon *et al.* 1989) and act as nutrient and sediment sinks (Short 1987). Seagrasses in coastal regions play important roles in maintaining sediment stability and water clarity. Coastal seagrass meadows are therefore an important resource economically and ecologically. Information on the species composition, abundance and distribution of seagrasses is used by management to zone for protection of seagrass habitats.

Accurate information on seagrass habitats (distribution, abundance and species composition) is therefore vital, although the type of questions asked by managers ultimately determines the sampling design implemented in surveys of seagrass habitats. Surveys which rely mostly on diving based operations can be difficult in turbid waters and when vast areas are to be covered. Diving based surveys also increase the risks to diver safety where dangerous marine animals occur. A reliable remote sensing technique for surveying seagrasses would help to reduce these risks and improve the intensity and resolution of data collected.

Current remote-sensing techniques (satellite and aerial imagery) are useful for mapping dense seagrass meadows in the clear waters of temperate regions, but in the tropics they are inadequate for detecting seagrasses of low biomass or in turbid water. Recent advances in acoustic techniques for surveying benthic habitats present new possibilities for applications in seagrass surveys in tropical Australia. We provide a preliminary evaluation of acoustic techniques for surveying tropical Queensland seagrass habitats and compared these techniques against currently-used diving-based survey methods.

1.1 Surveying techniques used in tropical seagrass habitats

Tropical seagrass habitats in north Queensland are currently surveyed using diving-based surveys coupled with various methods of remote sensing. Aerial reconnaissance (eg., by helicopter), aerial photography (visible and infra red), underwater video and satellite imaging can provide mapping information over a large area in minimal time and a permanent image of the seagrass habitat for historical reference. These methods provide information that is relatively precise, but can be expensive. The use of aerial surveys to obtain clear images of seagrass meadows is also limited to localities with low turbidity and high density seagrass habitat. Aerial surveys are best when determining seagrass coverage in intertidal or shallow sites. Coupled with intensive ground-truthed seagrass data, visual remote-sensing data can be used to map the distribution of high-density seagrass communities over large areas.

Dive-based surveys can be undertaken to examine seagrass meadow parameters at either broad or fine spatial scales. Although this method is labour intensive, it provides both qualitative and quantitative data. Qualitative information may be in the form of presence/absence, percent cover and/or species composition. Quantitative data may include density or biomass measures, species composition, seagrass growth characteristics and depth distribution at a particular site. A visual biomass estimation technique adapted from Mellors (1991) has been used extensively in north Queensland to determine seagrass biomass. This survey method requires extensive field resources (labour and time) and involves increasing risks to diver safety where dangerous marine animals occur.

1.2 Acoustic techniques

Acoustic/echo-sounding methods are an important tool in fisheries studies; mapping of sea-floor types, underwater vegetation, sediment and sub-bottom sediment types (Hundley *et al.* 1994; Collins and Gregory 1996). They are also used in underwater searching for sunken vessels, downed aircraft and pipelines. The advantages of using acoustic energy over visual or other mediums to retrieve information in the marine environment, lie in the fact that sound travels underwater without appreciable attenuation relative to optical methods in the sea. Acoustic signals are less sensitive than light to turbidity or depth. Data is collected at higher spatial resolution than is usual with dive-based surveys and large areas can be surveyed quickly. Data is recorded digitally on PC in the field, and can be linked with GPS and processed into GIS format.

Vessel-mounted acoustic systems coupled with a GPS have been used previously to map seagrass habitats in temperate (Higginbottom *et al.* 1995) and tropical (Anon. 1995) waters. The system uses high frequency acoustic pulses to map the substrate and associated biota of the immediate area within a chosen swath width (approx. 50 m). An acoustic technique used in Lake Macquarie to map temperate *Zostera capricorni* meadows distinguished medium density (500-3500 shoots m⁻²) from high density (>3500 shoots m⁻²) habitat (Hundley *et al.* 1994). The same technique was used to map *Zostera* meadows of lower density (280 shoots m⁻²) at Narrabeen Lake, NSW (Hundley and Denning 1994). Reports of acoustic techniques for mapping tropical seagrass habitats are few. The SAVEW acoustic system was used to map low density *Halophila*, *Cymodocea*, *Syringodium* and *Zostera* in tropical U.S. waters (Anon. 1995; Bruce Sabol, Pers. Comm.).

1.3 Objectives

We provide a preliminary evaluation of an acoustic technique to map tropical seagrass habitats, for possible application in Shoalwater Bay and other tropical Australian localities. Test surveys were conducted in Cairns Harbour, an accessible locality which supports a range of coastal seagrass habitats typical of tropical Australia. Seagrasses were surveyed using two methods: the acoustic remote sensing technique, and a visual estimation technique (adapted from Mellors (1991)). The results from the two methods were then compared. Logistics are considered in a simple cost-benefit analysis and recommendations on applicability of this technique are made. The objectives of the study were:

- 1. To determine the viability of an acoustic technique for mapping edges of tropical seagrass meadows in selected intertidal and subtidal sites.*
- 2. To assess the effectiveness of an acoustic technique for determining the biomass of seagrass in intertidal and subtidal sites.*
- 3. To determine the effectiveness of an acoustic surveying technique for describing sediment type in intertidal and subtidal sites.*
- 4. To assess the efficiency in mapping tropical seagrass habitats using acoustic techniques against current dive survey methods.*

2. METHODS

2.1 Site details

Three areas in Cairns Harbour (Figure 1) were chosen for testing the acoustic survey technique:

- 1) Bessie Point
- 2) Cairns Esplanade
- 3) Ellie Point.

Survey areas were selected from previous studies (Lee Long *et al.* 1996), current aerial photographs and diver reconnaissance, to include a range of seagrass and sediment types. Survey areas extended across meadows and depth profiles, into bare substrate, to test the acoustic techniques ability to differentiate habitat types and locate meadow boundaries. The survey areas measured 250-1300 m length and 50-200 m wide and were marked with surface buoys. An echo-sound swath width of approximately 50 m was used, based on previous acoustic survey experience in temperate seagrass meadows.

Seagrass habitat and sediment type were heterogenous between and within each survey area. Seagrass species included *Halophila ovalis*, *Halodule pinifolia*, *Halodule uninervis* (wide and narrow leaves), *Zostera capricorni* and *Cymodocea serrulata*. Seagrass habitats with above-ground biomass less than 5 g dry wt m⁻² were specifically included for testing, as they can be important food sources for dugongs. Sediments ranged from fine mud to coarse sand / shell (grain size classes <63µm to >2000µm).

2.2 Experimental design

Surveys of the selected areas were conducted between 8 - 17 May 1996. Each area was first surveyed by acoustic techniques, followed immediately after by diving. Differential GPS was used to record the position of each acoustic data point accurate to within 15-20 m and each seagrass and sediment sampling site, accurate to within 3 m. Biomass and sediment data was spatially linked to acoustic data for statistical analyses (eg., calibration of acoustic data).

2.3 Acoustic surveying

A general description of the acoustic technique is provided below and details of the technology appear in Appendix 1. Seagrass and sediments were surveyed using two acoustic systems: a conical beam transducer and a fan beam transducer. Combinations of the character and amplitude of the recorded echoes and the geometry of the transducer output allow 3 interpretations of the acoustic data

1. habitat boundary mapping (from fan beam transducer)
2. seagrass biomass estimation (from conical beam with grazing angle of approximately 10°).
3. sediment type (from conical beam with grazing angle at 45° or 90°).

For these trials the transducer was mounted in a fixed position over the side of the vessel (Figure 2a). An alternative rig which uses the fan beam transducer attached to a "towfish", towed a fixed distance and depth behind the vessel, was used at Ellie Point. The acoustic system uses high-frequency (420 kHz) pulses of sound which, when reflected or scattered from sediments or seagrass, return to a receiver to be recorded digitally. The geometry of the interaction between the acoustic beam and the environment is used to calculate the correct position and strength of acoustic signals received from the target environment. Echosound

time-series data was recorded on two systems: a) as a real-time hardcopy printout on an EPC 9800 Thermal Chart Recorder and b) stored to computer hard disk (Figure 2b).

A total of twenty-nine (29) acoustic survey transects (approx. 9 at each survey area) were conducted to ensure adequate coverage of the survey areas and to allow for some redundancy of data.

2.3.1 Mapping seagrass habitat edges

Seagrass habitats were mapped in all survey areas using the fan beam system. This technique uses a beam of sound that is very narrow (2°) in the horizontal plane, and broad (60° to 90°) in the vertical plane. This geometry has the effect of a sonar “sweep” of a sea-floor area typically 1 m wide by 70 m long in a direction perpendicular to the vessel track.

The fan beam output provides an “acoustic map image” of the environment, which includes seagrass, sediments and any other sea-floor features. The spatially located acoustic data (recorded in decibels) was plotted using a colour scale to represent acoustic signal intensity. Background knowledge and experience (by Offshore Scientific Pty. Ltd) was required to interpret the processed acoustic data in map form because this data is partly qualitative in nature. Interpretation of the acoustic images involved monitoring the depth-sounder on board the survey vessel and interpretation of raw data from the fan beam sonar to identify seabed features which could affect the interpretation of the acoustic image (Appendix 1).

Acoustic map images were generated by Surfer[®] software. Seagrass meadow edges were interpreted on the acoustic maps from the distribution of acoustic intensity (decibels) over the survey area and from biomass information obtained from dive surveys.

2.3.2 Seagrass biomass

A conical beam acoustic system was used for surveying seagrass biomass at each of the three sites. A very narrow beam of sound at a low grazing angle (10°) was emitted from the transducer and reflected from above-ground biota. Echo intensity (decibels) received by the transducer is affected by the density of seagrass (ie., high plant density results in higher echo amplitude) and other sea-bed factors. To calibrate the acoustic data, mean echo responses were plotted and tested against seagrass biomass data at a range of spatial scales from 10 m radius up to one hectare. Seagrass above-ground biomass data in this case was obtained by visual estimates, calibrated to measures of above-ground biomass g dry wt m⁻² (section 2.4.2).

2.3.3 Sediment type

Sediment type was surveyed along transects using either a backscatter technique (conical beam at fixed grazing angle of 45°) or multiple reflection technique (conical beam at grazing angle of 90°).

Acoustic data points were collected at 1 m intervals for the length of the survey transects and ground-truth samples were taken very close to these transects. Acoustic intensity (decibels) provided a relative scale (not absolute) measure of sediment grain size parameters, and were tested against 1) percentage coarse sand composition 2) percentage mud composition and 3) “weighted averages” of sediment grain size, taken from ground-truth samples.

2.4 Dive-based Surveying

All data from the dive-based surveys was entered onto a Geographic Information System (GIS). The GIS basemap used an aerial photograph of Trinity Inlet (provided by the Beach

Protection Authority) rectified to Australian Map Grid (AMG) co-ordinates. A GIS of above-ground seagrass biomass, and another of sediment type, was created in MapInfo[®].

2.4.1 Mapping Seagrass Habitat Edges

Boundaries of seagrass meadows were determined based on the GPS fix at each survey site. The error in determining the edge of the seagrass meadow was set at ± 10 m either side of the meadow edge and was based on the distance between survey sites. Other errors associated with mapping, such as GPS and position of diver under the vessel, were assumed to be embedded within this range.

2.4.2 Seagrass Biomass

Estimates of above-ground seagrass biomass (5 replicates of a 0.25 m² quadrat), seagrass species composition, % cover of algae and sediment characteristics were recorded at each haphazardly placed site (approx. 5 m in radius). The relative proportion of biomass of each seagrass species within each survey quadrat was also recorded.

Above-ground biomass was determined by a "visual estimates of biomass" technique described by Mellors (1991). At each site, divers recorded an estimated rank of seagrass biomass. Height of seagrass leaves, leaf morphology and shoot density influence the above-ground seagrass biomass rank estimated by the diver. At times of low visibility an illuminated underwater seagrass viewer was used. Each diver's ranking scale of seagrass biomass was calibrated against a set of quadrats which were harvested and the above-ground dry biomass measured (g DW m⁻²).

Seagrass species were identified according to Kuo and McComb (1989). A differential Global Positioning System (GPS) was used to determine geographic location of all sites (post-processed for differential correction to accuracy's better than 3 m), so that seagrass biomass at any site could be related to acoustic data at that site.

2.4.3 Sediment Type

45 sediment samples were obtained from the three survey areas using a standard 0.0625m² van Veen grab. Grain size analysis was determined by sieving each sample through a series of standard meshes. Percent composition (of dry weight) was determined for each grain size category: shell grit, rock gravel (>2000 μ m), coarse sand (>500 μ m), sand (>250 μ m), fine sand (>63 μ m) and mud (<63 μ m). An average sediment grain size for each sediment sample, was calculated from the sediment composition data and numerical rank "weightings" assigned to each grain size class.

2.5 Comparison of methods

2.5.1 Mapping Seagrass Habitat Edges

Seagrass habitat edges determined by the acoustic and dive-based technique were compared visually by placing spatially located layers of both acoustic and dive-based survey data on one GIS. Meadow boundaries from a previous diver based survey (December 1993) were also referred to for comparison.

2.5.2 Estimating Seagrass Biomass

Conical beam acoustic data was tested against seagrass biomass using correlation and regression analysis. Tests were conducted using data from two spatial scales: 1) acoustic data averaged within a 10 m radius from each dive location (fine scale), 2) data pooled within locations (ie., Ellie Point, Bessie Point and Esplanade). Tests were also conducted using data

at three abundance scales: 1) biomass $>5 \text{ g DW m}^{-2}$, 2) biomass $>10 \text{ g DW m}^{-2}$ and 3) all biomasses pooled.

2.5.3. Sediment type

Acoustic survey trials for sediments were undertaken only at Bessie Point and Ellie Point. Acoustic data was pooled every 10 m along the survey transects and plotted against

- 1) proportion of mud (% weight of sediment sample of grain size $<63\mu\text{m}$),
- 2) proportion of coarse sand (% weight of sediment sample of grain size 500-2000 μm) and
- 3) the “weighted averages” of sediment grain size. Acoustic data were tested against each of these sediment parameters for correlation and regression.

Tests were conducted between acoustic and diver based data to determine if they were correlated, and if so, how much of the variation could be explained by the relationship.



Figure 1. Areas surveyed in Trinity Inlet by an acoustic technique and dive based survey, May 1996.

A)

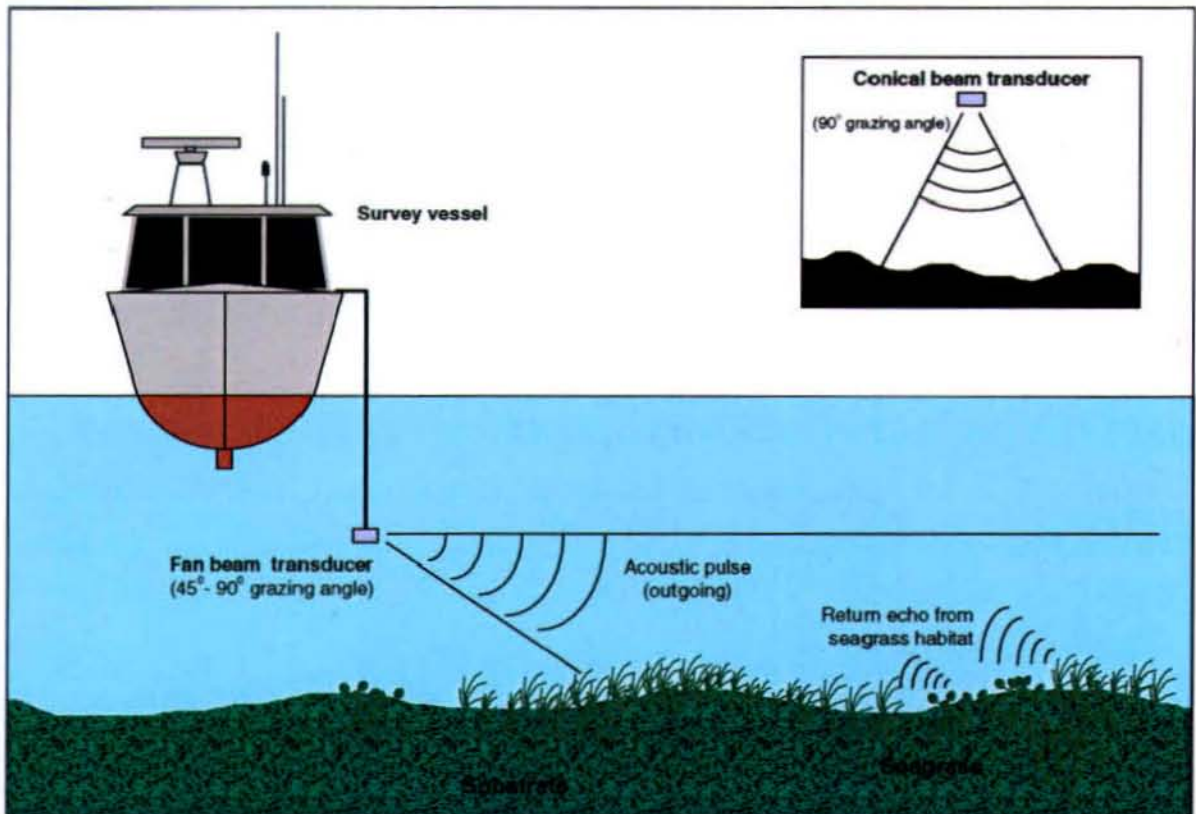

B)

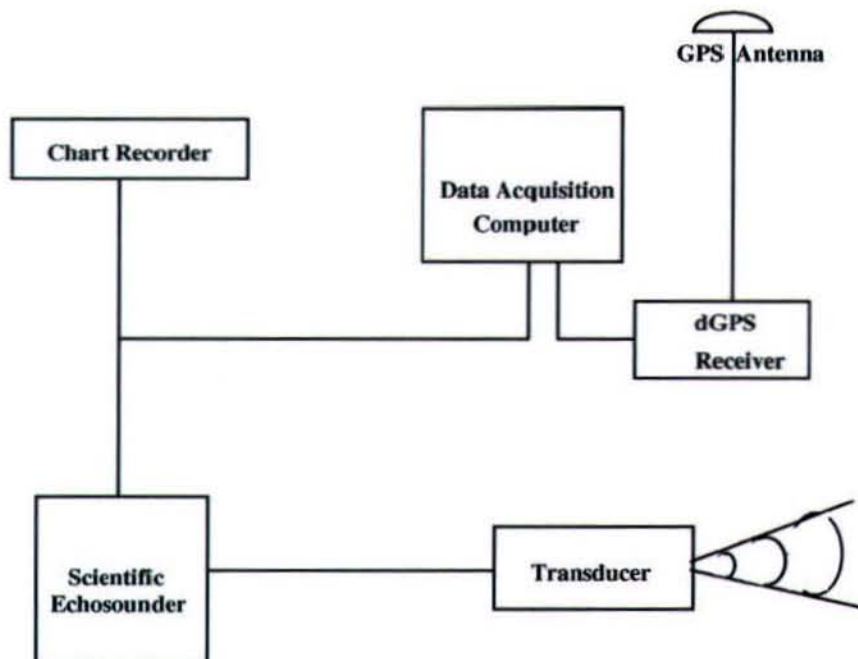

Figure 2. Equipment used in acoustic survey of benthic environments: a) configuration of fan beam transducer when deployed from survey vessel and b) hardware of acoustic systems.

3. RESULTS

3.1 Mapping seagrass habitat edges

A total of 123 sites within the three survey areas were ground-truthed by divers. Ellie Point and Bessie Point seagrass habitat edges were interpreted from the images created by acoustic data and seagrass biomass ground-truth (diver) data. Acoustic survey data were collected at a much higher spatial frequency than dive-based data (Figures 3, 4 and 5). No meadow edge existed within the Esplanade survey area (Figure 3).

3.1.1. Fan beam mapping using a transducer on a "towfish"

The Ellie Point meadow edge interpreted from acoustic mapping corresponded closely with the edge defined from diver data in the present survey. There were however, insufficient dive sites in the present survey to clearly define a meadow edge for the Ellie Point meadow. Acoustic images of the Ellie Point survey area identified a 40 x 40 m area of bare substrate which the dive-based survey did not sample in the present survey. The same area was identified as low biomass (<5 g DW. m⁻²) *Halophila ovalis* habitat in December 1993 (Lee Long *et al.* 1996) (Figure 4).

3.1.2. Fan beam mapping using a fixed transducer

At Bessie Point, an area of low biomass *Halodule pinifolia* (3 sites with <5 g DW m⁻²) ground-truthed by divers was not detected using the acoustic method, and therefore not interpreted as within the seagrass habitat (Figure 4). These three sites represent 13 % of low-density (<5g DW m²) sites where both acoustic and ground truth data were collected.

At the Esplanade, both the acoustic method and divers identified a seagrass habitat with no meadow boundary within the survey area (Figure 3). The acoustic method also mapped the Esplanade meadow as a patchy habitat, but divers in the present survey always found some seagrass present in quadrats. In December 1993 however, divers recorded a patchy *Zostera capricorni* habitat with a meadow edge just inside the area surveyed by acoustic methods in the present survey (Figure 4).

3.2 Estimating seagrass biomass

66 sites were examined by both diver and acoustic methods (Table 1, Figure 6). Ground-truthed (diver) biomass was significantly higher at the Esplanade survey area than at the other 2 survey areas (Table 1) (ANOVA $F=16.27$; d.f.=63, 2; $P=0.001$).

Table 1. Seagrass species, ground-truthed mean above ground biomass and the number of sites examined by both acoustic technique and divers at each survey area in Cairns Harbour.

| Survey area | # sites | Species | Mean biomass ±SE (range) |
|-------------|---------|--|-----------------------------|
| Bessie Pt | 35 | <i>Halodule pinifolia</i> | 7.12 ±0.71 (0 - 31.53) |
| Ellie Pt | 18 | <i>Zostera capricorni</i> / <i>Halodule uninervis</i> (thin & wide) / <i>Halodule pinifolia</i> / <i>Halophila ovalis</i> / <i>Cymodocea serrulata</i> | 9.40 ±0.76 (0.1 - 22.92) |
| Esplanade | 13 | <i>Zostera capricorni</i> / <i>Cymodocea serrulata</i> | 21.93 ±1.00 (8.94 - 40.13) |

3.2.1. Finescale (sites with 10 m radius)

The only statistically significant correlations between acoustic (conical beam transducer data) and ground-truthed above-ground seagrass biomass were at Bessie Point, when biomass was >5 g (Table 2).

Table 2. Results of correlation and regression analysis between acoustic data (decibels) and above-ground seagrass biomass (g DW m⁻²) at each survey area using conical beam (grazing angle 10°). Asterisk = significant

| Grain size | Correlation coefficient | r ² | d.f | F | P | Relationship |
|------------------------|-------------------------|----------------|-------|-------|--------|----------------------------|
| Bessie Pt | | | | | | |
| All quadrats/site | 0.1443 | | 34 | | | nil |
| Quadrat biomass >5.0g | 0.4754* | 0.23 | 16, 1 | 4.67 | 0.0462 | = 0.5193x decibel + 6.4540 |
| Quadrat biomass >10.0g | 0.7979* | 0.64 | 13, 1 | 22.77 | 0.0004 | = 102.07x decibel - 6883.3 |
| Ellie Pt | | | | | | |
| All samples | 0.1941 | | 17 | | | nil |
| Quadrat biomass >5.0g | 0.2541 | | 15 | | | nil |
| Quadrat biomass >10.0g | -0.0044 | | 6 | | | nil |
| Esplanade | | | | | | |
| All samples | 0.1120 | | 12 | | | nil |
| Quadrat biomass >10.0g | 0.0979 | | 12 | | | nil |

Seagrass abundance was plotted on GIS for each site dived (Figures. 3, 4 & 5), however as there was no correlation between the acoustic and biomass data, acoustic maps of seagrass biomass could not be generated with the same resolution of biomass as obtained by divers.

3.2.2. Broadscale (regions >1 hectare)

Seagrass above-ground biomass data (all sites pooled) was significantly different between regions (>1 ha) at Ellie Point and Bessie Point. However, as acoustic signal intensity was highly variable throughout each of the survey areas, no significant difference between regions could be detected (Table 3).

Table 3. Results of two-sample T-tests analysis between regions within each survey area for acoustic (decibels) and diver (g DW m⁻²) methods. Asterisk = significant

| Method | T | d.f | P |
|------------------|------|------|---------|
| Bessie Pt | | | |
| Acoustic method | 0.68 | 33 | 0.50 |
| Diver method | 5.16 | 25.3 | ●0.001* |
| Ellie Pt | | | |
| Acoustic method | 0.75 | 16 | 0.47 |
| Diver method | 3.89 | 16.7 | 0.003* |
| Esplanade | | | |
| Acoustic method | 1.48 | 11 | 0.17 |
| Diver method | 0.62 | 11 | 0.55 |

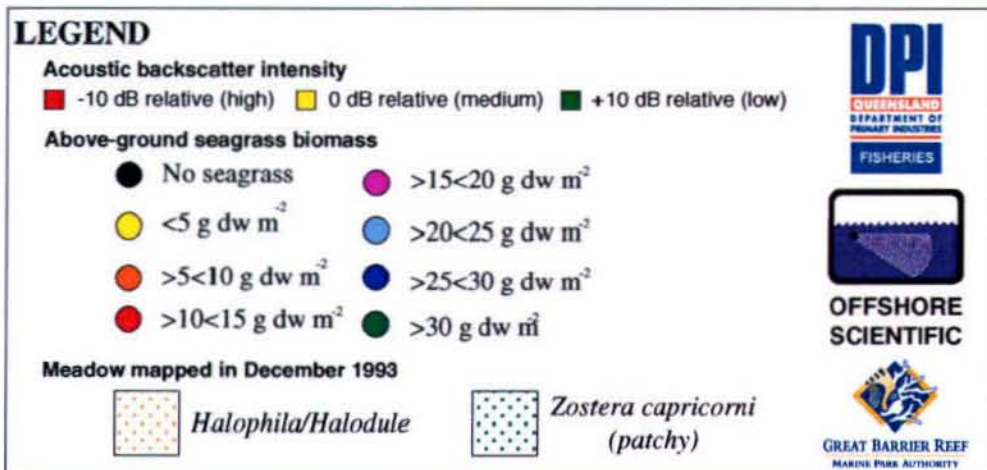
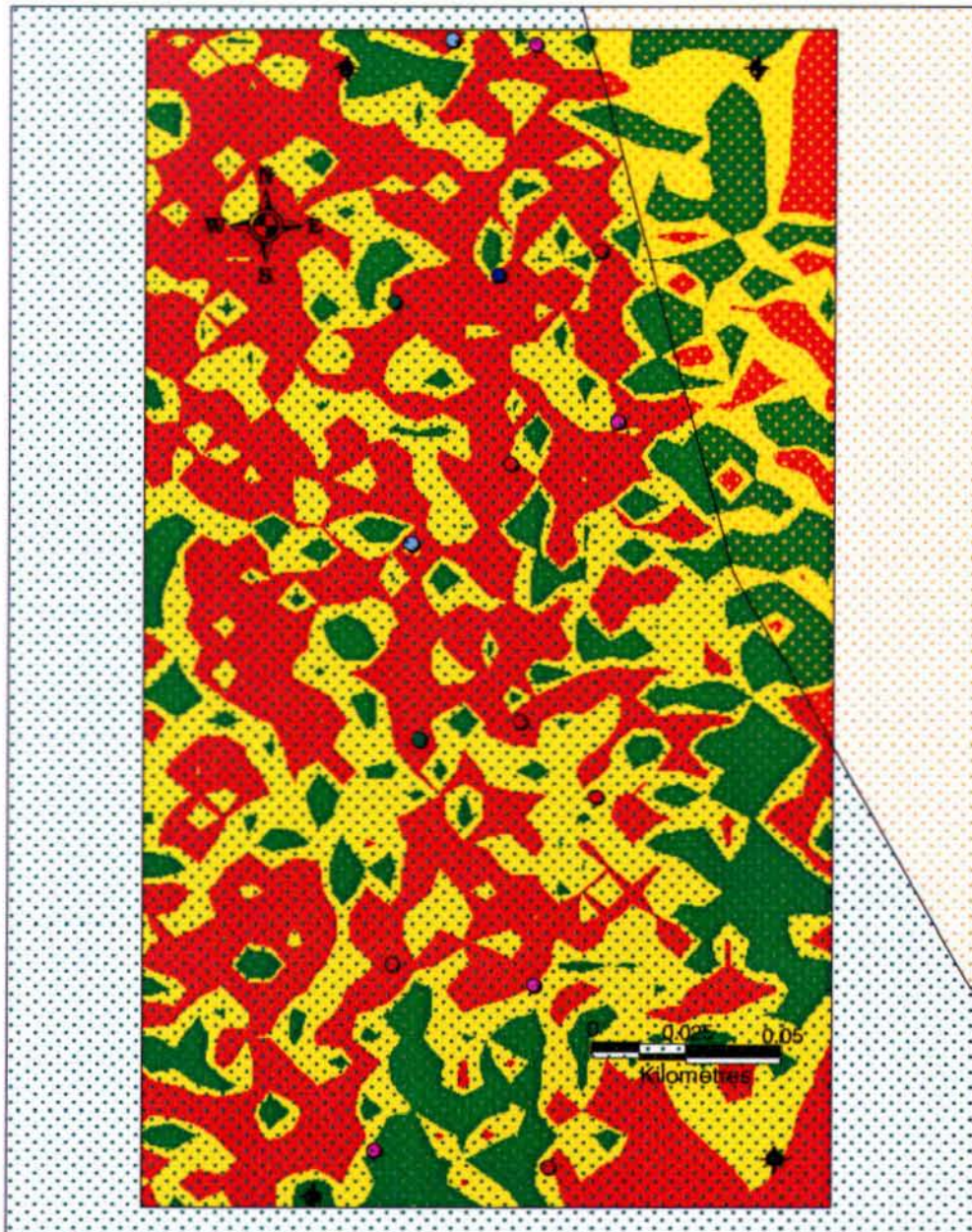

Figure 3. Acoustic map of Esplanade seagrass habitat, May 1996.

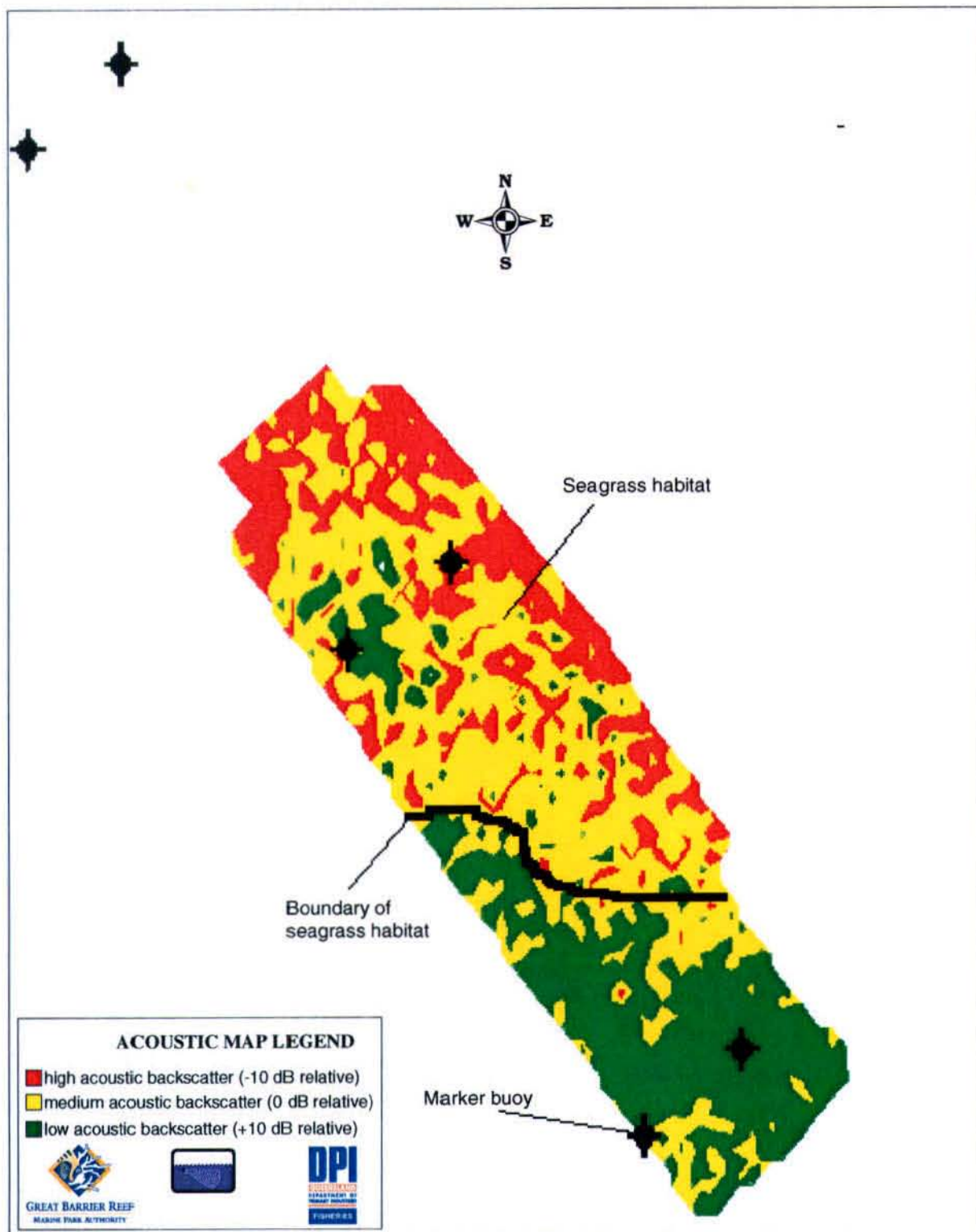
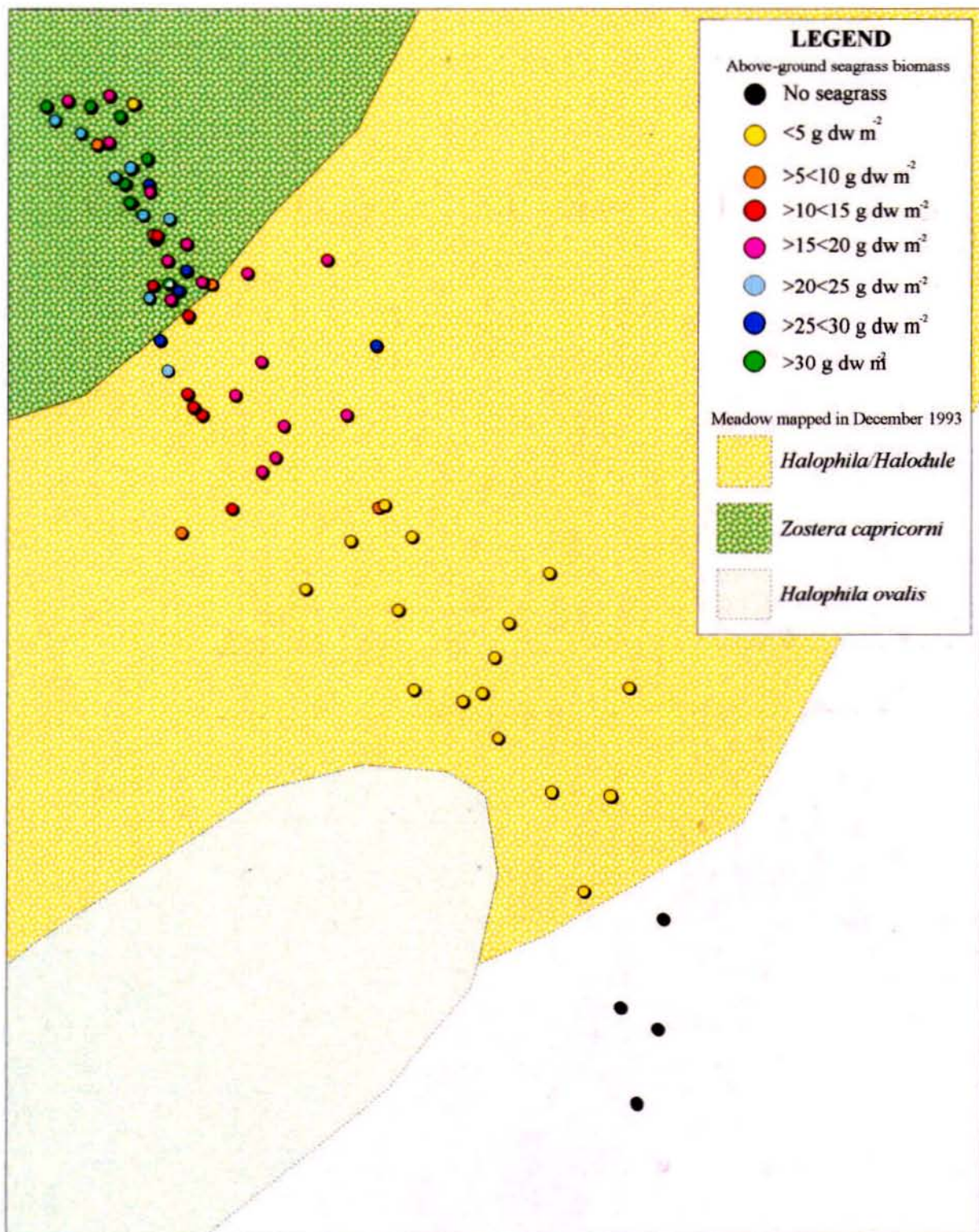
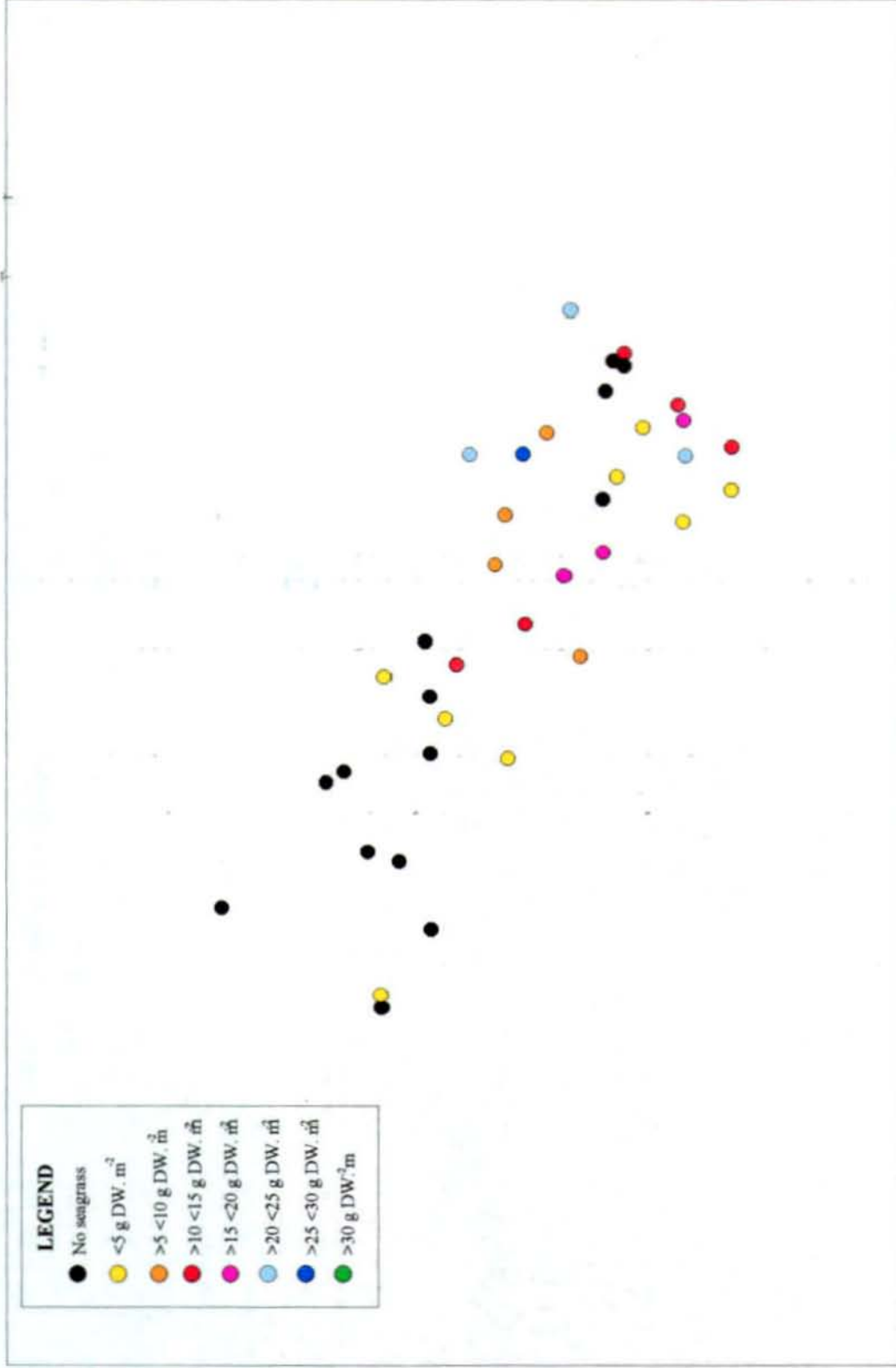

Figure 4. Acoustic map of Ellie Point seagrass habitat, May 1996.
(dark line is interpreted edge of seagrass meadow)



Transparency = ground truthed (diver) sites with above-ground seagrass biomass (May 1996) and meadow boundaries (December 1993).



Transparency = ground truthed (dive) sites with above-ground seagrass biomass.

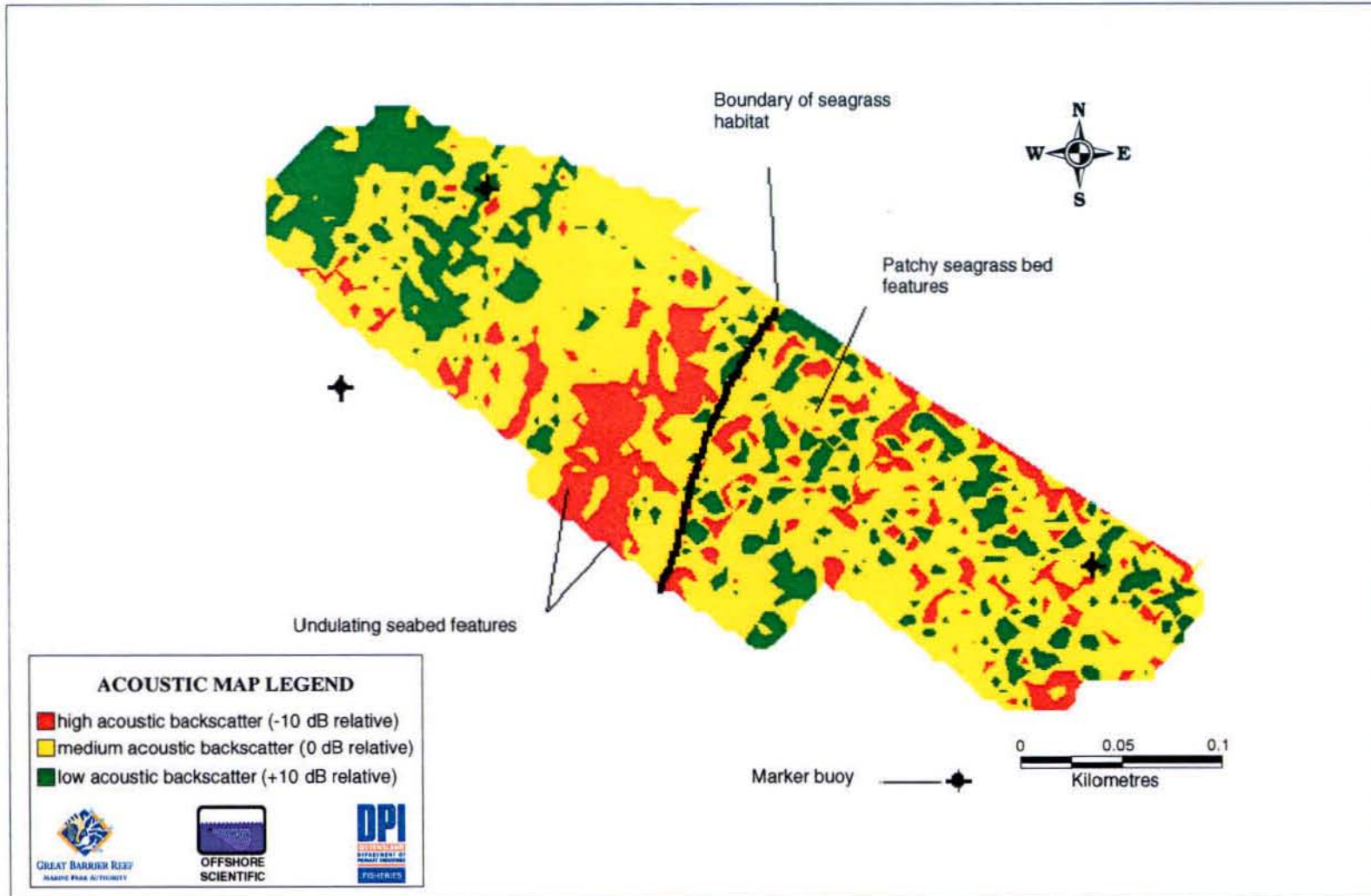

Figure 5 Acoustic map of seagrass areas at Bessie Point, May 1996.
(dark line is interpreted edge of seagrass habitat)

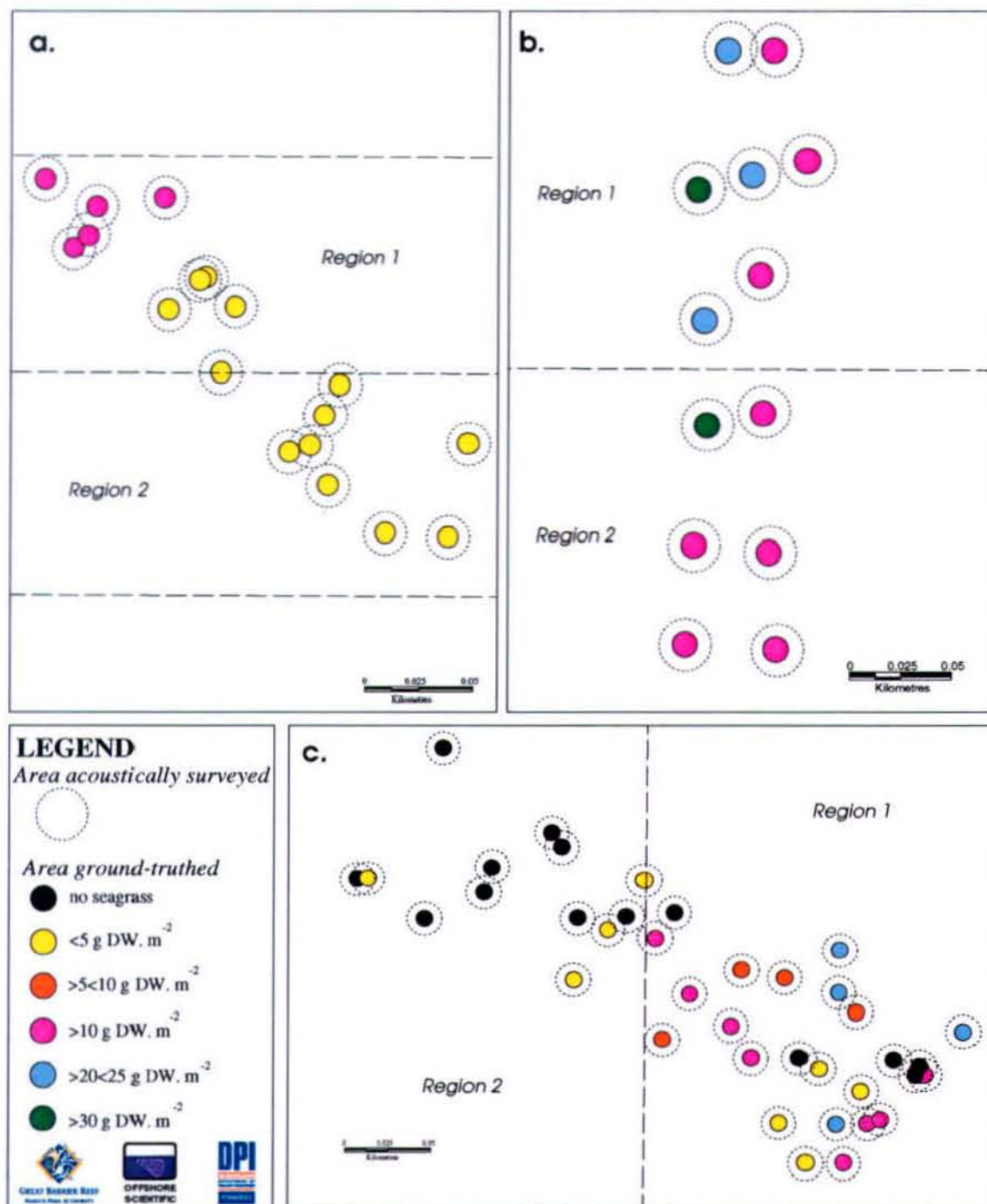

Figure 6. Sites in each survey area at which above-ground seagrass biomass was ground-truthed by divers and examined using acoustic conical beam (10 deg grazing angle).
 a. Ellie Point; b. Esplanade; c. Bessie Point.

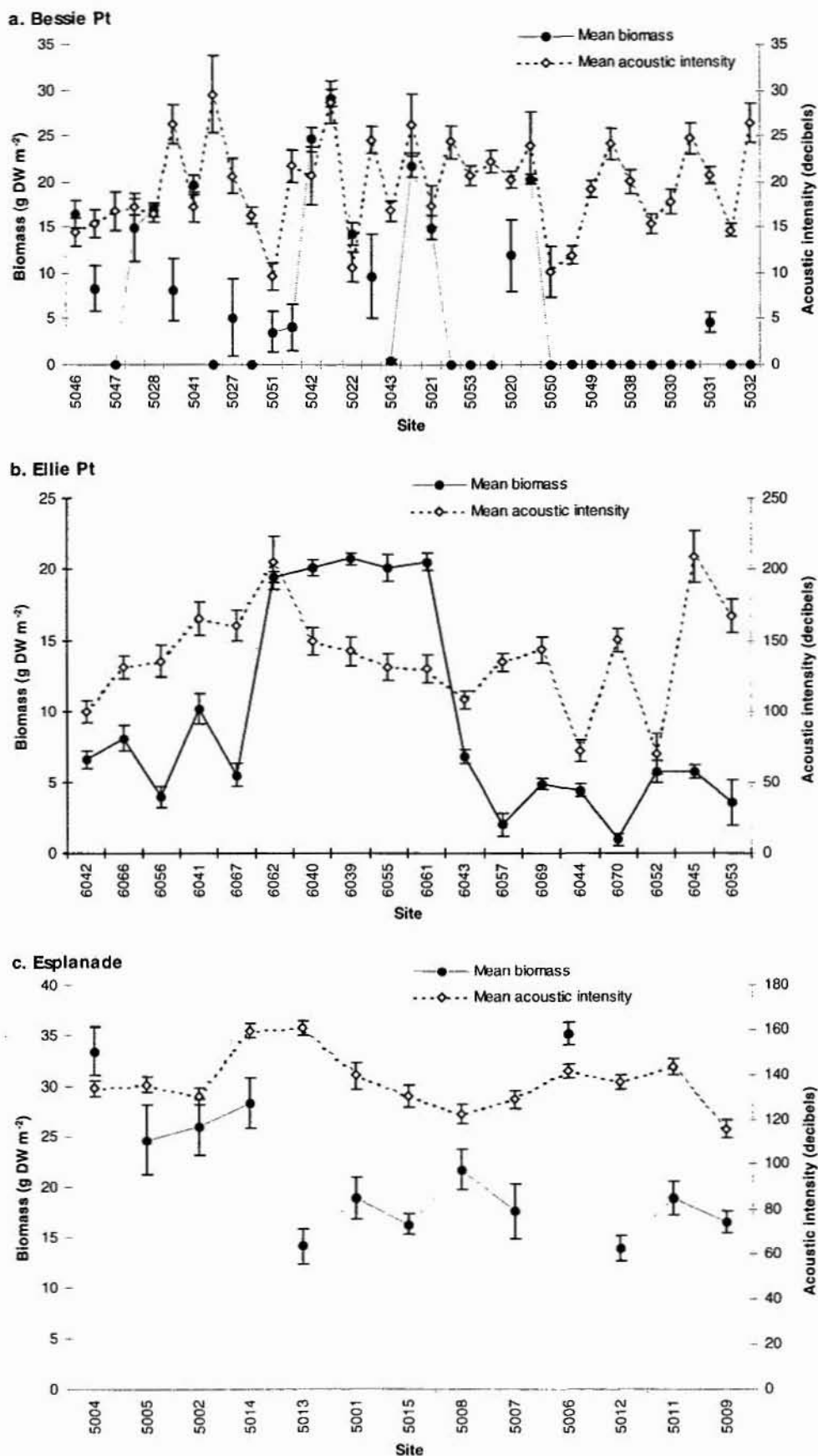

Figure 7. Mean acoustic intensity (decibels) and ground-truthed biomass (g DW m⁻²) at each site examined at each survey area in Cairns Harbour.

3.3 Describing sediment type

Acoustic data was tested against

- a) percent coarse-sand (sediment fraction between 500 and 2000 μ m),
- b) percent mud (sediment fraction less than 63 μ m) and
- c) “weighted averages” of grain size.

The multiple reflection technique (grazing angle 90°) and acoustic backscatter technique (grazing angle 45°) were tested at Bessie Point and Ellie Point, respectively. As neither technique was tested at both survey sites, no comparison of techniques is possible.

Acoustic data from the multiple reflection conical beam technique used at Bessie Point was significantly correlated with percent coarse sand, percent mud and the “weighted average” of sediment grain size (Table 4, Figure 8). 67% of the variance in the percentage of coarse sand was explained by a positive relationship with acoustic signal strength (decibels). A positive relationship was also found between acoustic signal strength and weighted average of sediment grain size (64% of the variance explained). For percent mud however, the relationship with acoustic signal strength was inverse and only explained 32 % of the variance.

Table 4. Results of correlation and regression analysis between acoustic data (decibels) and sediment grain size at Bessie Point using multiple reflection technique (conical beam grazing angle 90°). Critical $r_{(14)}=0.426$, asterisk = significant

| Grain size | Correlation coefficient | r^2 | d.f | F | P | Relationship |
|------------------|-------------------------|-------|-------|-------|--------|----------------------------|
| % coarse sand | 0.8155* | 0.67 | 13, 1 | 25.82 | 0.0002 | = 5.8441x decibel - 399.4 |
| % mud | -0.5684* | 0.32 | 13, 1 | 6.20 | 0.0271 | = -3.954x decibel + 306.05 |
| Weighted average | 0.7979* | 0.64 | 13, 1 | 22.77 | 0.0004 | = 102.07x decibel - 6883.3 |

Acoustic data (decibels) from the acoustic backscatter technique used at Ellie Point was significantly correlated with percent mud only (Table 5, Figure 9). The acoustic signal was inversely related to mud (41% of the variance explained).

Table 5. Results of correlation and regression analysis between acoustic data (decibels) and sediment grain size at Ellie Point using backscatter technique (conical beam grazing angle 45°). Critical $r_{(11)}=0.476$, asterisk = significant

| Grain size | Correlation coefficient | r^2 | d.f | F | P | Relationship |
|------------------|-------------------------|-------|-------|------|-------|----------------------------|
| % coarse sand | -0.4198 | | | | | nil |
| % mud | -0.6420* | 0.41 | 13, 1 | 7.01 | 0.024 | = 4711.6 - 69.094x decibel |
| Weighted average | 0.4728 | | | | | nil |

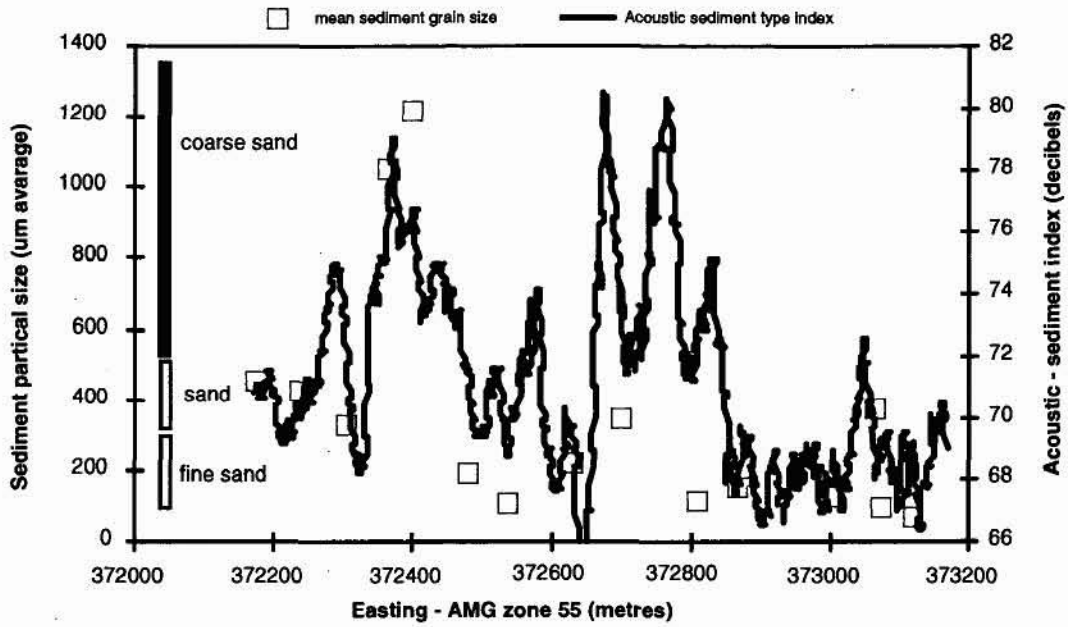

Figure 8. Acoustic response measured in decibels (blue line) and mean sediment grain-size (magenta squares) along survey transect at Bessie Point.

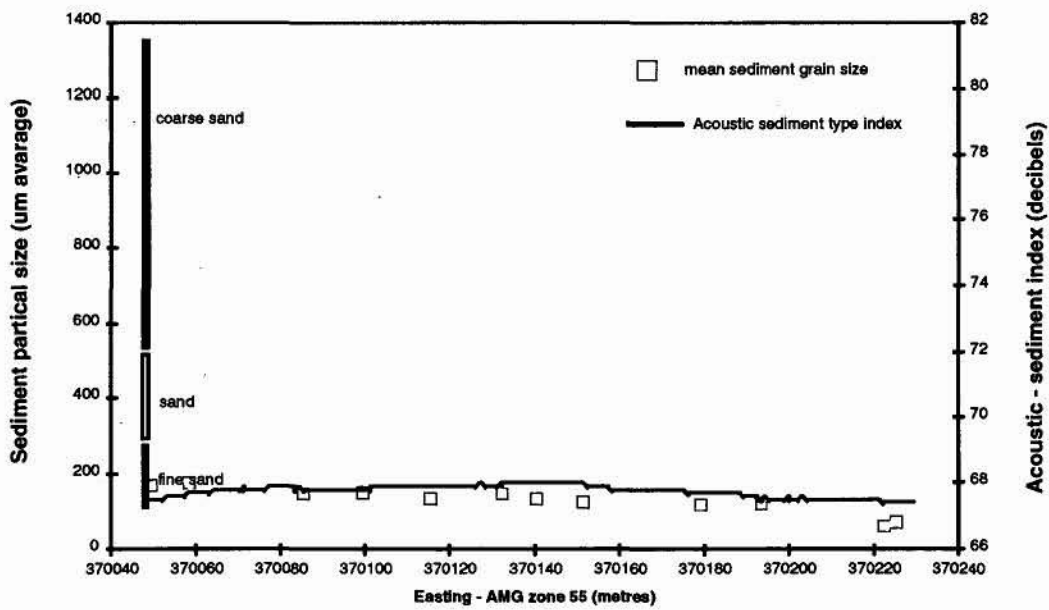

Figure 9. Acoustic response measured in decibels (blue line) and mean sediment grain-size (magenta squares) along survey transect at Ellie Point.

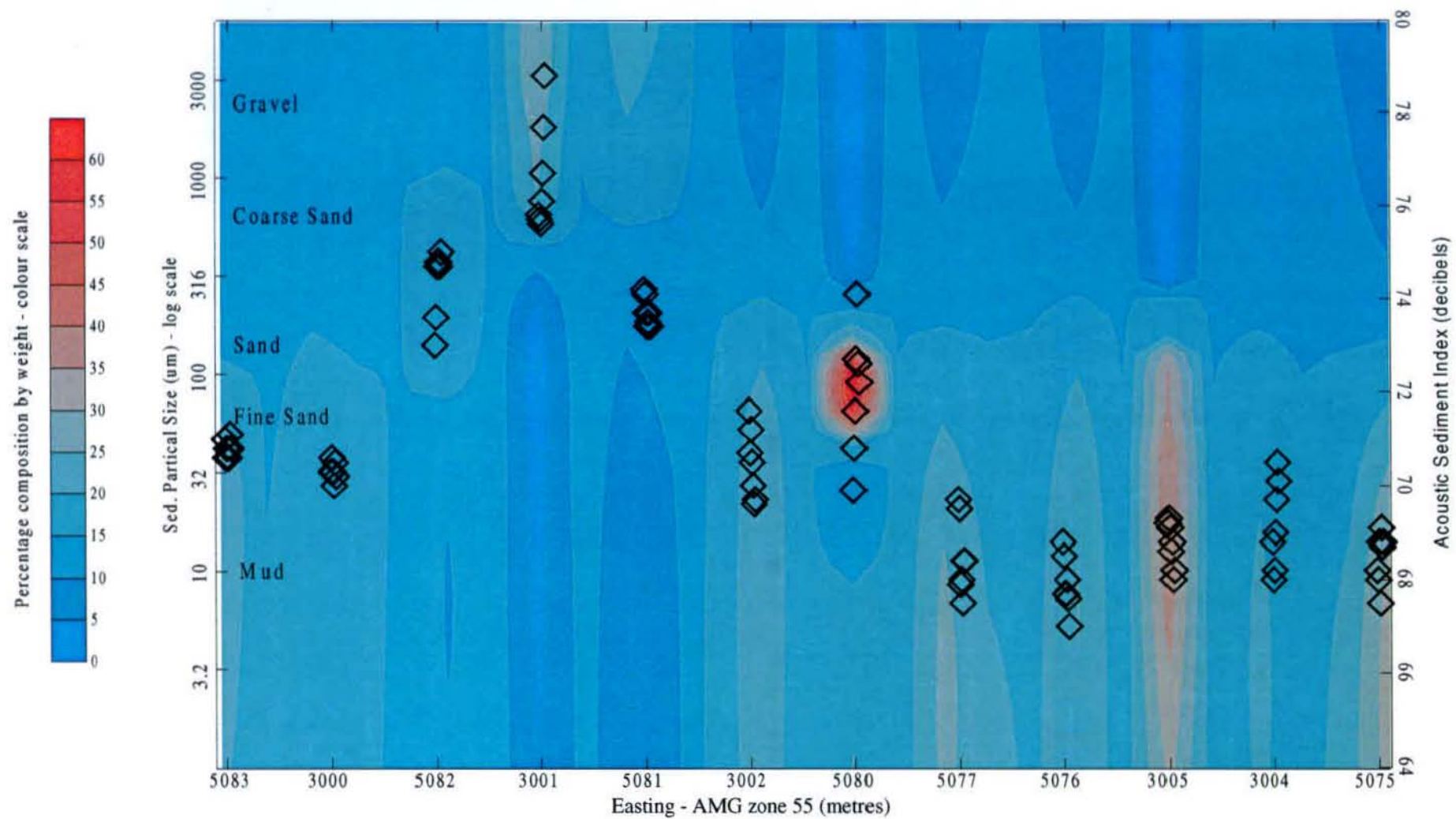

Figure 10. Comparison of acoustic intensity and ground-truthed sediment composition for each sediment sampling site at Bessie Point.

4. DISCUSSION

4.1 Mapping seagrass meadow edges

Edges of seagrass meadows interpreted from acoustic methods (fan-beam technique) corresponded closely to boundaries interpreted from dive-based surveying. Low biomass (<5 g DW.m⁻²) sites at Ellie Point were successfully interpreted as seagrass habitat from the acoustic method. But three low biomass sites at the edge of the Bessie Point meadow were interpreted from acoustic images as bare substrate. This mis-interpretation of the three seagrass sites may be due to one or a combination of factors:

1. the sites were too small in area to be detected by the sonar in the configuration used at Bessie Point;
2. the sites were too low in density to be detected by the sonar in the configuration used at Bessie Point (*Halodule pinifolia* has very narrow leaves and possibly reflect very little acoustic energy).
3. the resolution of the data at these sites was corrupted by factors such as errors in positioning data and data processing; causing data “smear” and increasing the difficulty of the interpretation of the fan beam data;
4. irregular bottom topography (sand rows and blow-outs) may have decreased the detection capability of the acoustic system and interpretation process.

A combination of these factors is the most likely cause for this result. Low biomass sites were identified at Ellie Point using the fan beam technique and transducer attached to a “towfish”. Ellie Point data quality after processing was high and it is likely that the “towfish” dampens transducer motion (rolling and pitching) and hence increased the detection capability of the acoustic system and interpretation process.

Bathymetry, transducer instability, seagrass morphology and sediment type all influence fan-beam acoustic data, and information on all of these is used when interpreting fan-beam data to draw seagrass meadow boundaries. Successful application of acoustic techniques for mapping seagrass meadow boundaries in tropical Australia will require further advances in minimising the influence of bathymetry, transducer movement, seagrass morphologies, sediment type, etc. on acoustic data.

Low biomass *Halophila* and *Halodule* communities dominate many localities in northeastern Australia, (Lee Long *et al.* 1993), and are important habitat for dugongs and green sea turtles. Our trials indicate that acoustic surveying techniques may be appropriate for mapping low-biomass habitat in areas with flat bottom, but of limited use on undulating and deeply channelled banks. Large areas of Shoalwater Bay for example, support low-biomass seagrass habitat which is restricted to intertidal pools and drainage channels up to 1.5 m deep (Lee Long *et al.* 1997). Acoustic techniques would need to be modified to accommodate such variable bottom topography.

The efficiency of the fan beam system in distinguishing between seagrass and macro-algae habitat was not tested in this survey. Algae (eg., *Caulerpa*, *Halimeda*, *Dictyota*, *Udotea*, and *Padina*) and seagrass communities can appear similar in habitat structure and are not easily differentiated using most remote sensing methods. Acoustic survey techniques, as with other remote sensing techniques, require intensive ground-truthing in some areas to avoid misrepresenting algae as seagrasses.

4.2 Seagrass biomass

Seagrass biomass in Cairns Harbour could not be determined with any accuracy by the conical beam mapping technique in this survey. Although correlations with biomass >5 g DW. m^{-2} were detected at Bessie Point, the technique could not replicate the results using identical methods at the other survey areas. The lack of any significant correlation between acoustic data and seagrass biomass data is probably the result of a combination of many sources of error. Spatial errors in the data (smearing) can be caused by GPS position-fixing and the influence of surface chop on the orientation of the transducer. Irregular bottom topography and variation (patchiness at all scales) in seagrass species composition may also contribute to variability in the acoustic data.

Bessie Point acoustic images included large positioning errors because of large gaps in GPS data. Ellie Point images were correctly positioned, but shallow, rough waters caused large variation in the transducer angle and hence large errors in signal strength received from the target environment.

A large area of high-density seagrass habitat in shallow water was included for study, but became inaccessible to the acoustic survey vessel, and seagrass habitat greater than 20 g DW. m^{-2} was not included in the analyses. Seagrass density has been successfully mapped using acoustic methods in temperate (Offshore Scientific P/L, 1994) and tropical (Anon. 1995) marine areas. Temperate species of grasses (*Posidonia spp*, *Amphibolis spp*, and *Zostera marina*) and wide-bladed tropical seagrasses are generally large in structure and height, and acoustic signals reflected from densely vegetated habitat can be easily distinguished against background changes in sediment, bottom topography, etc.

With little statistically significant correlations to describe seagrass biomass from acoustic data, the minimum above-ground biomass detectable by the acoustic method could not be determined. The capacity of remote sensing information to discern low biomass habitat from bare substrate is important in mapping tropical seagrasses (section 4.1). In northern Australia large areas of low-biomass habitat dominated by the tropical seagrass species *Halophila ovalis*, *Halodule uninervis* (thin) and *Halodule pinifolia* are important food resources for dugong, a species declared as vulnerable. Information on these habitat types is important for conservation management of dugong in northern Australia. Acoustic and other remote sensing methods will continue to require technical improvements and extensive ground truthing (by diving or grab samples) to become reliable tools for mapping low-biomass seagrass habitats.

Acoustic and other remote-sensing techniques can potentially improve the spatial and abundance resolution of habitat surveys, but reliable measures and maps of seagrass abundance will require further technical developments to minimise spatial and measurement errors. Sources of error in conical beam mapping of seagrass biomass include: vessel positioning error, vertical and horizontal movement of the transducer (influenced by wind and surface chop), seagrass species (variations in plant morphology affecting backscatter strength), seagrass patchiness, sediment type, bathymetry and positioning error in differential GPS fixes (approximately 1 - 5 m). The influence of surface chop and seabed undulations are also exacerbated in shallow water (<2 m), but they can be reduced by using a towfish sonar transducer instead of mounting the transducer onto a vessel which is rocking and pitching. The use of a static or stable transducer at single points to collect acoustic data would also greatly reduce these errors. Finally, acoustic reflectors could be used to verify/quantify any positioning errors.

The difference in acoustic signal strength from one seagrass community (eg., *Zostera* at Ellie Point) to another (eg., *Halodule pinifolia* at Bessie Point), irrespective of biomass, illustrates an effect of seagrass plant morphologies on acoustic survey data. Fibrous and wide-blade seagrasses may result in a stronger acoustic response than delicate and narrow-bladed leaves. Seagrass patchiness is also a source of error in acoustic surveying as it is in any sampling technique.

The influence of sediment type on acoustic measures of seagrass biomass has not been determined, and may have an effect when seagrass biomass is very low.

4.3 Other seagrass mapping information

Detailed information on seagrasses, such as general seagrass health, epiphyte cover, canopy height, dugong feeding trails, fruiting and flowering, and fine scale changes in community structure, are not recorded in an acoustic survey and still require observation and sampling by divers or video. Once this type of information is obtained for a monitoring locality, sampling by divers can be stratified and minimised in future monitoring events.

4.4 Sediment mapping

Grain size distribution is an important influence on distributions of infauna species in the tropics (Jones 1984; Chevillon and de-Forges 1988; Dall *et al.* 1990; Long and Poiner 1994), but ecological significance has also been attached to simple parameters, such as the proportion of mud, in marine sediments. For example, some penaeid prawn species show preference to sediments consisting of more than 25% mud (Somers 1987, 1994).

Percent mud was significantly correlated (inversely) with acoustic data and is probably one of the most useful parameters for calibrating against acoustic data when mapping sediments for marine ecology purposes. Conical beam surveying techniques appear to be very efficient at identifying changes in percent mud, but even better at predicting percent coarse sand. Increasing percentage of coarse sand (and decreasing proportion of muds) corresponded with higher decibel readings.

Coastal and marine sediments are usually mapped by collecting grab samples of sediment, but limitations in sample storage and laboratory processing time render this method very expensive. Acoustic techniques which are adequately calibrated against single parameters of sediment type can economically provide sediment maps at higher than normal resolution. The limitation is that acoustic backscatter signal represents an average of the acoustic reflectivity of the target area. This value is also calibrated to a single parameter of sediment type such as "mean grain size" or percent mud and cannot describe the distribution of sediment grain size. A single value cannot reflect important information on the range and variance of sediment grain size in sediments, ie., it cannot distinguish a well-sorted from a well-mixed grain size distribution. Sediment grain size composition data overlaid with acoustic data for sites at Bessie Point (Figure 10) visually illustrates some similarities between acoustic measurements and actual sediment grain size composition, but also confirms that acoustic data is usually clumped about a mean value irrespective of whether grain size distribution is clumped (eg., well sorted) or spread (eg., well mixed sediments).

The most robust technique for sediment mapping appears to be the vertical incidence (90°, multiple reflection) technique, which correlated better than the backscatter (45° incidence) technique to parameters of sediment type. Acoustic signals correlated to sediment type much more strongly than to seagrass biomass. Sediments may often be less patchy than vegetated habitat, but to ensure reliable calibration of acoustic data, ground-truth or calibration samples still need to be collected as close as possible to the acoustic survey track.

4.5 Efficiencies of survey methods

Acoustic surveying (fan beam and conical beam) can obtain data at high spatial resolution over 500-600 ha per day (60 ha per hour, based on a 10 hour day) with 4 days of analyses and reporting per field day (completed by 2 acoustic personnel, and excluding ground-truth divers). The extent of ground truthing is determined by the scale of the survey and frequency of changes in habitat type. Dive-based surveys obtain data at a much lower resolution to that from acoustic methods, but are able to cover large areas quickly (eg., for medium- to broad-scale surveys). Using the Shoalwater Bay April 1996 survey (Lee Long *et al.* 1997) as a guide, two vessels with 7 dive personnel can cover up to 11 km of coastline (approximately 2,100 ha of seabed) per day. For each field day, approximately 6 person-days are needed for analysis and writing of the report. When acoustic technology is further refined for tropical environments, the technology can be made more accessible and cost effective for seagrass survey teams via technology transfer, equipment hire, etc..

Acoustic surveying may not detect very low seagrass biomass habitat, but high biomass habitat may be mapped at higher spatial resolution than from dive surveying. Areas of low biomass can only be reliably mapped using divers. A combination of acoustic and dive survey methods in large scale surveys may help to improve the spatial resolution of mapping high density meadows, and ensure that low biomass habitat is mapped and variations in seagrass habitat type are detected.

Variation in seagrass species, patchiness of the meadow, sediments and bottom topography all influence acoustic backscatter signals. Acoustic data needs to be ground-truthed during each survey event and the intensity of ground-truthing of acoustic data depends on the scale at which these influencing factors vary over the survey area. Initial surveys of new areas will require frequent ground-truth sampling. Once the spatial pattern of these influencing factors is known, the level of ground-truth sampling in subsequent monitoring surveys can be moderated.

The acoustic techniques trialed here show potential advantages against dive-based surveys. With further improvements, and with ground-truth sampling, acoustic survey techniques can provide high-resolution maps of tropical seagrass habitat boundaries. They potentially reduce the need for large numbers of dives in turbid, sub-tidal waters where other remote sensing methods are limited and where dangerous marine animals and other safety risks can occur. Advantages of these acoustic techniques may be greatest in fine-scale mapping and monitoring of small areas of high density habitat, where acoustic techniques can be intensively ground-truthed and the influence of seagrass species, sediment type and bottom topography on acoustic signals can be economically measured.

Improvements in acoustic techniques are recommended. Integrating real-time dGPS (position and time) data into the acoustic recording system and ensuring reliable data capture from satellites should reduce data redundancy and errors in positioning of acoustic data points. Acoustic reflectors or markers in known positions can also provide spatial reference points within the acoustic survey data. Techniques which stabilise the transducer (eg., use of a

towfish or fixed-point platforms) will help to reduce errors in signal strength and position of data points. For current acoustic survey techniques the minimum acceptable water depth is approximately 0.7m, and for fixed transducers the maximum acceptable surface chop is approximately 0.8m wave height.

↳ 5. CONCLUSIONS AND RECOMMENDATIONS

There is an increasing need to find remote sensing techniques which will help minimise time spent by divers in waters, where a) survey costs are high, b) spatial resolution of mapping requires improvement and c) dangerous marine animals and other potential safety risks occur. Our preliminary trials show that acoustic techniques can be applied to mapping seagrass meadow boundaries, but not for determining seagrass biomass in tropical northern Australia.

Boundaries of seagrass meadows were successfully mapped using a fan beam system, combined with ground-truth information. Obvious changes in the backscatter when checked with seagrass ground-truth data can help identify seagrass habitat boundaries, however patchy cover of low-density seagrass habitat cannot be mapped with confidence.

Meadow boundaries drawn from fan beam data can be continuous and at a much higher resolution than is normally possible from dive-based surveys alone. In turbid, sub-tidal waters where the aid of aerial photography is not possible, the accuracy of meadow boundaries drawn from dive surveys are usually dependant on the distance between survey sites.

Acoustic survey methods and techniques require further development before they can be used to reliably map seagrass biomass distribution in tropical seagrasses. We recommend that modifications be made to reduce transducer instability, ensure the use of real-time dGPS systems and reliable satellite data capture, and measure the effects of seagrass species, sediment type and bottom topography on acoustic signal strength.

Remote sensing techniques can only be applicable to monitoring seagrass biomass if they can measure changes which are statistically defensible and which are considered ecologically important. Present conical beam transponder/transducer hardware and signal processing software appear able to measure fine-resolution differences in acoustic signal response, however this acoustic-signal resolution for measuring seagrass biomass is masked by the large errors caused by transducer instability, environment patchiness, sediment type and bottom topography. Refinement of the conical beam technique is also required to discern low-biomass seagrass habitat from bare substrate.

Acoustic techniques can provide sediment mapping information at spatial resolutions better than normally available from traditional sediment mapping methods. Acoustic data shows strong statistical relationships with some parameters of sediment composition, but cannot be used to describe details of sediment grain-size composition (eg., grain size range, variance and distribution). Acoustic data can be used in some situations as a proxy for percent mud - a useful sediment parameter in marine ecology studies. Acoustic data also correlated to a weighted average of sediment grain size, but valuable ecological information on grain-size composition is missed when this parameter is used alone.

Acoustic signals provide a relative measure of changes in benthic habitat parameters. Absolute data on these habitat parameters must be obtained from ground truth sampling and be used to calibrate the conical and fan beam acoustic data. Ground-truthing is necessary for every survey event to interpret graphs and images created with the acoustic technique. The

frequency and intensity of ground-truth sampling required to interpret acoustic images and plots will depend on the spatial scales at which influencing parameters change.

Advantages of the acoustic techniques for habitat mapping could be greatest in monitoring small areas where the variation in seagrass species, sediment type and bottom topography are known and ground truth sampling can be minimised. For large scale mapping, a combination of acoustic and dive survey methods, might help improve spatial resolution of mapping high density habitat and ensure low biomass and variations in habitat type are still detected.

Acknowledgments

We thank Paul Leeson, Anthony Roelofs, Leane Makey, Mark Connell (DPI, Northern Fisheries Centre) and Nick Tidswell (Offshore Scientific Services) for their assistance in the field. We also thank David Reid for statistical advice and Dr Rob Coles for valuable comments on the draft manuscript. This study was funded by the Great Barrier Reef Marine Park Authority and the Department of Primary Industries, Queensland. The Australian Cooperative Research Centre Program through the CRC for the Ecological Sustainable Development of the GBR also contributed with in-kind and salary support for two of the authors.

6. REFERENCES

- Anonymous (1995). Automatic Detection and Mapping of Submerged Aquatic Vegetation - the SAV Early Warning System (SAVEWS) - U.S. Army Engineer Waterways Experiment Station Information Package, Vicksburg, MS. 3pp.
- Chevillon, C. and de-Forges, B.R. (1988). Sediments and bionomic mapping on soft bottom communities in the south-western lagoon of New Caledonia. *Proceedings of the Sixth International Coral Reef Symposium. Townsville, Australia. 2*, 589-94.
- Coles, R.G. and Lee Long, W.J. (1985). Juvenile prawn biology and the distribution of seagrass prawn nursery grounds in the south-eastern Gulf of Carpentaria. In 'Second Australian National Prawn Seminar, Cleveland.' (Eds P. P. Rothlisberg, D. J. Hill and D. J. Staples.) pp. 55-60. (NPS2: Cleveland, Australia.).
- Coles, R.G., Lee Long, W.J., Watson, R.A. and Derbyshire, K.J. (1993). Distribution of seagrasses, and their fish and penaeid prawn communities, in Cairns Harbour, a tropical estuary, northern Queensland, Australia. In 'Tropical Seagrass Ecosystems; Structure and Dynamics in the Indo-West Pacific.' *Australian Journal of Marine and Freshwater Research 44*, 193-210.
- Collins, W. & Gregory, R. (1996). A Digital Approach to Seabed Classification. *Sea Technology*. August 1996. pp 83-89.
- Dall, W., Hill, B.J., Rothlisberg, P.C. and Staples, D.J. (1990). The Biology of the Penaeidae. In *Advances in Marine Biology Vol 27* (Eds., J.H.S. Blaxter and A.J. Southward). Academic Press, London, San Diego. 489 pp.
- Higginbottom, I., Hundley, A. and Pauly, T. (1995). A Desktop Study of Some Acoustic Seabed Classification Systems. Unpublished report by Sonar Data Tasmania/Offshore Scientific Pty Ltd. 21 pp.
- Hundley, A. and Denning, K. (1994). Report on the Use of an Acoustic Method for Mapping Seagrass Density and Location. Unpublished report by Offshore Scientific Pty Ltd, Report No. 940401. 11 pp.
- Hundley, A., Zabloudil, K. and Norall, T. (1994). A Review of Acoustic Applications for Marine Resource Examination and Monitoring. In 'Proceedings of the Sixth Pacific Congress on Marine Science & Technology, Townsville QLD. July 1994.'
- Jones, A.R. (1984). Sedimentary relationships and community structure of benthic crustacean assemblages of reef associated sediments at Lizard Island, Great Barrier Reef. *Coral Reefs 3*(2), 101-11.
- Kuo, J. and McComb, A.J. (1989). Seagrass taxonomy, structure and development. In 'Biology of seagrasses: A treatise on the biology of seagrasses with special reference to the Australian region.' (Eds A.W.D. Larkum, A.J. McComb and S.A. Shepherd) Chpt.2. pp.6-73. (Elsevier, New York).
- Lanyon, J., Limpus, C.J. and Marsh, H. (1989). Dugongs and turtles: grazers in the seagrass system. In 'Biology of seagrasses: A treatise on the biology of seagrasses with special reference to the Australian region.' (Eds A.W.D. Larkum, A.J. McComb and S.A. Shepherd) Chpt.18. pp.610-634. (Elsevier, New York).

- Lee Long, W.J., Mellors, J.E. and Coles, R.G. (1993). Seagrasses between Cape York and Hervey Bay, Queensland, Australia. *Australian Journal of Marine and Freshwater Research*. **44**(1), 19-31.
- Lee Long, W.J., McKenzie, L.J. and Coles, R.G. (1996). Seagrass communities in the Shoalwater Bay region, Queensland - Spring (September) 1995 and Autumn (April) 1996. Queensland Department of Primary Industries Information Series QI96042 (QDPI, Brisbane) 36 pp.
- Long, B.G. and Poiner, I.R. (1994). Infaunal benthic community structure and function in the Gulf of Carpentaria, northern Australia. *Australian Journal of Marine and Freshwater Research*. **45** (3), 293-316.
- Mellors, J.E. (1991). An evaluation of a rapid visual technique for estimating seagrass biomass. *Aquatic Botany* **42**, 67-73.
- Short, F.T. (1987). Effects of sediment nutrients on seagrasses: Literature review and mesocosm experiment. *Aquatic Botany* **27**, 41-57.
- Somers, I.F. (1987). Sediment type as a factor in the distribution of commercial prawn species in the Western Gulf of Carpentaria, Australia. *Australian Journal of Marine and Freshwater Research*. **38**, 133-149.
- Somers, I.F. (1994). Species composition and distribution of commercial penaeid prawn catches in the Gulf of Carpentaria, Australia, in relation to depth and sediment type. *Australian Journal of Marine and Freshwater Research*. **45** (3), 317-35.
- Urick, R.J. (1983). Principles of Underwater Sound. 3rd Edn. McGraw-Hill, New York. 423 pp.
- Watson, R.A., Coles, R.G. and Lee Long, W.J. (1993). Simulation estimates of annual yield, and landed value for commercial penaeid prawns from a tropical estuary, northern Queensland, Australia. *Australian Journal of Marine and Freshwater Research* **44**(1), 211-219.

APPENDIX 1. DETAILS OF THE ACOUSTIC TECHNIQUE

Acoustic surveying

In these trials, acoustic survey transects were repeated (approx. 9 times) in each survey area to ensure adequate coverage of the survey areas and to allow for some redundancy of data. Seagrass and sediments were surveyed acoustically using two echo-sounding systems: a conical beam transducer and a fan beam transducer. Combinations of the character and amplitude of the recorded echoes and the geometry of the transducer output provided 3 interpretations of the acoustic data - broad habitat mapping (fan beam), seagrass density estimation (conical beam at grazing angle of approximately 10 degrees) and sediment type (conical beam).

Two transducer rigs can be used: 1) fixed transducer “mounted over the side” of the vessel, and 2) transducer attached to a towfish, towed a fixed distance behind the vessel. Minimum water depths acceptable for both rigs is approximately 0.7 m. The acoustic system emits high frequency (420 kHz) pulses of sound which, after reflecting or scattering from sediments or seagrass, return to a receiver to be recorded digitally. The geometry of the interaction between the acoustic beam and the environment was later used to calculate the mapping position and strength of each returned signal (see below: Processing of Digital Data). Echosound data was recorded on two systems: a) as a real-time hardcopy printout on an EPC 9800 Thermal Chart Recorder and b) stored to a computer hard disk.

All acoustic data was tagged with Universal Time data and linked to dGPS data which was collected simultaneously. Geographic position of the transducer and all acoustic data was calculated using the geometry of transducer and acoustic signals relative to the GPS antenna. Each acoustic technique used is described below.

Mapping seagrass habitat boundaries

The fan beam system was used for broad habitat mapping to obtain seagrass habitat boundaries. This technique uses a beam of sound that is very narrow in the horizontal plane (2°), and wide in the vertical plane (60° to 90°). This geometry has the effect of a sonar “sweep” of a seafloor area typically 1 metre wide by 70 metres long in a direction perpendicular to vessel track. The methods used here are described by Hundley et al (1994) and technical details of scanning sonars are discussed by Urick (1983).

Fan beam outputs provide an “acoustic map image” of the environment, which include seagrass and any other seafloor features. These acoustic map images are made up of colour contours representing decibel levels of the echo signal from the environment. Processed acoustic data in map form is only semi-quantitative and requires background knowledge and experience to interpret. Interpretation of the acoustic image requires monitoring the depth-sounder on board the survey vessel and interpreting unusual features in the raw data from the fan beam sonar. Processing and interpreting the fan beam data involve the following steps.

1) Examination of raw data and log notes taken during data collection

All features in the raw data are examined and log notes on depth, bottom topography and other visible seabed features are used to identify the location of features such as piers, seawalls, rock outcrops and even seagrass beds.

2) Processing of digital data

The digital data (recorded on hard disk) is (or pooled) into areas (“bins”) of approximately 3 metres by 3 metres square. This data then has a “transmission loss” correction applied to it to remove effects of signal reduction with distance. This correction equalises the signal strength so that a given target, for example, at a distance of 40 metres (for example) will have an equal backscatter strength as that same target at 5 metres. These “bins” are then merged with navigation/positioning data to yield a X and Y coordinates for each bin. Each bin therefore has a X, Y and Z coordinate, with the X and Y coordinates as spatial and the Z coordinate as the “backscatter strength” of that bin.

3) Acoustic Image / Map generation

“SURFER” software is used to generate an acoustic contour image with the X, Y and Z coordinate data mentioned above. This geo-coded data can be presented in any image format, using contours, colours or surface plots to represent the decibel strength for each bin area.

4) Interpretation of Map Image

Interpretation of the map image requires examination of the raw data and any significant auxiliary information on bathymetry and other seabed features identified in Step 1. This process requires background technical knowledge and experience with acoustic/echosounding data and is similar to interpretation of aerial photographs. Seagrass biomass or seagrass density data, obtained from ground-truth sampling, is used to verify the interpretation of this acoustic (remote sensing) data. This interpretation yields seagrass bed (habitat) boundaries by identifying areas with seagrass against areas with no seagrass (bare substrate).

This method does not yield information on seagrass or algae species composition or other factors such as abundance of epiphytic algae. This information must be derived from ground-truth sampling.

Mapping Sediment type

Several acoustic techniques are available for mapping sediments (Higginbottom et al. 1994). Urick (1983) outlines basic technical aspects of acoustic-sediment interactions. The strength of the recorded acoustic signal is influenced by the grain sizes of the sediment within the sound beam footprint (ie., larger grain sizes, including coarse sands, reflect at a higher decibel frequency). Two techniques were attempted in these trials. The (downward-looking) vertical conical beam technique uses a narrow conical beam of sound (similar to a flashlight beam) projected at a fixed angle of 90°. Echo strength data is collected from the first and second bottom echoes. Comparison of these two echoes yields information on sediment type (Collins and Gregory 1996). Calibration of the acoustic data (with sediment data obtained from grab samples) is necessary for accurate description of the range of sediment types found during a given survey. Collection and processing of acoustic data for sediment mapping with the **vertical (90°) incidence technique** includes the following steps.

1) Data collection

Acoustic echo information from the seafloor is collected at intervals of approximately 1 metre along the survey transect, and is recorded to hard disk.

2) Data processing/display

Acoustic data is processed and merged with the positioning data. These values are averaged for each 5-10 m interval are then reduced to decibel levels. and the averaged data are tested against ground-truth data.

The 45° conical beam technique (with the conical beam sonar as described above projected at 45° downward) relies on the backscatter strength (at 45° incidence) to be an indicator of sediment type as described in Urick(1983). The technique involves:

1)Data Collection

The acoustic backscatter from the sediment is recorded to hard disk at approximately 1 metre intervals along the survey transect.

2)Data Processing / Display

The recorded echo strength from the 45° sediment acoustic backscatter is isolated and a moving average function may then be applied to the data which acts as a smoothing operator. This operation has the effect of averaging the backscatter on a scale of between 5 and 10 metres, and reduces any possible effects of transducer motion and seabed topography. This sediment indicator is then reduced to a decibel level. The acoustic sediment indicators are then merged with the positioning data and these data are calibrated to ground-truth data.