

УДК 621.316

A PROBLEM OF POWER SUPPLY OF MICROPROCESSOR-BASED PROTECTIVE RELAYS AT EMERGENCY MODE

Gurevich Vladimir, Ph.D.

Israel Electric Corp., Central Electric Laboratory

POB 10, Haifa 31000, Israel

Fax: (+1) 603-308-5909, E-mail: gurevich2@bezeqint.net

Розглянуто проблему електроживлення мікропроцесорних пристроїв релейного захисту на підстанціях зі змінною та постійною оперативною напругою в аварійних режимах. Рекомендовано застосовувати конденсатори великої ємності та суперконденсатори як накопичувачі енергії для короткочасного живлення захисних реле в аварійних режимах.

Рассматривается проблема электропитания микропроцессорных устройств релейной защиты на подстанциях с переменным и постоянным оперативным напряжением в аварийных режимах. Рекомендуется использовать конденсаторы большой емкости и суперконденсаторы в качестве накопителей энергии для кратковременного питания защитных реле в аварийных режимах.

As is known, both auxiliary AC and DC voltages are used at power substations. Use of DC auxiliary voltage increases the essential reliability of relay protection due to use of a powerful battery, capable of supporting the required voltage level on the crucial elements of the substation at emergency mode with the AC power network disconnected. However, this increase of reliability comes at the cost of an essential rise in price of the substation and its maintenance. On the other hand, electromechanical relays of all types do not demand an external auxiliary power supply for proper operation, as their operation requires input signals only. There may be some problem when it is necessary to energize the trip coil of the high-voltage circuit breaker at loss of auxiliary voltage in the emergency mode, but this problem has been solved for a long time and simply enough through use of a storage capacitor. It is constantly charged at the normal operating mode from the AC auxiliary power supply through a rectifier and provides a power current pulse to the trip coil on operation of the protective relay in the emergency mode.



Fig. 1. One of the modern capacitor trip unit providing accumulation and long storage of energy for a feed of trip coil of circuit breaker at absence of an auxiliary voltage

A modern capacitor trip unit contains, in addition, little nickel-cadmium cells and a low-power solid state inverter for an output voltage of 250 V, through which

the main capacitor is constantly recharged from a battery while auxiliary voltage is disconnected.

The power capacity of the inverter makes mill watts which are spent only for compensation of self-discharging of the capacitor. Such compact devices (Fig. 1) are issued by many companies and allow keeping the capacitor charged for several days. Clearly, in such conditions, sufficient reliability of relay protection, even on an operative alternating current, is provided. For this reason, the operative alternating current is applied very widely.

The situation began to change with the introduction of microprocessor-based relays and the mass replacement of electromechanical relays by them. To the many problems caused by this transition [1, 2], one more problem was added. As is known, the internal switching-mode power supply, admitting use as auxiliary AC and DC voltages, has an overwhelming majority of microprocessor-based protective relays (MPR). Therefore, at first sight, there should be no reasons to interfere with the use of an auxiliary AC voltage on substations with MPR. The problem arises when there is not enough power for normal operation of an overwhelming majority of MPR and only the presence of corresponding input signals (as for electromechanical relays) and also requires a feed from an auxiliary supply. How will the MPR behave at loss of this feed at failure mode when the hard work of the microprocessor and other internal elements is required? How will the complex relay protection (containing some of MPR, incorporated in the common system by means of the network communication when there are also losses of auxiliary feed) function? How will the MPR behave during voltage sags (brief reductions in voltage, typically lasting from a cycle to a second or so, or tens of milliseconds to hundreds of milliseconds) during failure? We shall try to understand these questions.

The internal switching-mode power supply of the MPR contains, as a rule, a smoothing capacitor of rather large capacity, capable of supporting the function of the relay during a short time period. According to research which has been lead by General Electric [3] for various types of MPR this time interval takes 30 - 100 ms. In view of that time of reaction, the MPR for emergency op-

eration lays in the same interval and depends on that type of emergency mode, it is impossible to tell definitely, whether protection will have sufficient time to work properly. At any rate, it is not possible to guarantee its reliable work. It is a specially problematic functioning of protection relays with the time delay, for example the distance protection with several zones (steps of time delay, reaching up to 0.5 – 1.0 s and more). Also it is possible to only guess what will take place with the differential protection containing two remote complete sets of the relay, at loss of a feed of one of them only.

Voltage sags are the most common power disturbance. At a typical industrial site, it is not unusual to see several sags per year at the service entrance, and far more at equipment terminals.

These voltage sags can have many causes, among which may be peaks of magnetization currents, most often at inclusion of power transformers. Recessions and the rises of voltage arising sometimes at failures and in transient modes are especially dangerous when coming successively with small intervals of time. The level and duration of sags depend on a number of external factors, such as capacity of the transformer, impedance of a power line, remoteness of the relay from the substation transformer, the size of a cable through which feed circuits are executed, etc. MPR also have a wide interval of characteristics on allowable voltage reductions. As mentioned in [3], various types of MPR keeps working capability at auxiliary voltage reduction from the rated value of up to 70 - 180 V. Thus MPR with a rated voltage of 240 V supposes a greater (in percentage terms) voltage reduction than devices with a rated voltage 120 V. It is also known that any microprocessor device demands a long time from the moment of applying of a feed (auxiliary voltage) to full activation at normal mode. For a modern MPR with a built-in system of self-checking this time can reach up to 30 sec. It means that even after a short-term failure with auxiliary voltage (voltage sag) and subsequent restoring of voltage level, relay protection still will not function for a long time.

What is the solution to the problem offered by the experts [3] from General Electric? Fairly marking, that existing capacitor trip devices obviously are not sufficient to feed MPR, as reserved energy in them has enough only for creation of a short duration pulse of a current and absolutely not enough to feed MPR, the author comes to the conclusion that it is necessary to use an uninterrupted power supply (UPS) for feeding the MPR in an emergency mode. The second recommendation of the author - to add an additional blocking element (a timer, for example, or internal logic of MPR) will prevent closing of the circuit breaker before the MPR completely becomes activated. Both recommendations are quite legitimate. Here only usage UPS with a built-in battery is well known as a solution for maintenance of a feed of crucial consumers in an emergency mode. This solution has obvious foibles and restrictions (both economic and technical). Use of blocking for switching-on of the circuit breakers can be a very useful idea which should be undoubtedly used, however it does not always solve the problem as failures of

voltage feeding connected to operation of the circuit breaker is always a possibility.

In our opinion, a more simple and reliable solution of the problem is use of a special capacitor with large capacity connected in parallel to the feed circuit of every MPR instead of UPS usage. High-quality capacitors with large capacity and rated voltage of 450 - 500 V are sold today by many companies under the price, approximately, €150 - 200 and are not deficient, see the table below.

Table 1
Parameters of capacitors with large capacity and rated voltage of 450 - 500 V

Capacity, μF	Rated Voltage, V	Dimensions (diameter, height), mm	Manufacturer and capacitor type
6000	450	75 x 220	EVOX-RIFA PEH200YX460BQ
4700	450	90 x 146	BHC AEROVOX ALS30A472QP450
10.000	450	90 x 220	EVOX-RIFA PEH200YZ510TM
4000	500	76.2 x 142	Mallory DuraCap 002-3052
4000	450	76.2 x 142	CST-ARWIN HES402G450X5L
6900	500	76.2 x 220	CST-ARWIN CGH692T500X8L

Elementary calculation shows that when charged up to a 250 V one 5000 μF capacitor is capable of feeding a load with consumption power 30 - 70 VA up to voltage decreasing to a minimum level of 150 V during 3 - 5 s, that is quite enough for operation of the MPR in the emergency mode. Use of such capacitor for auxiliary voltage of 220 V AC requires, naturally, a rectifier and some more auxiliary elements (Fig. 2).

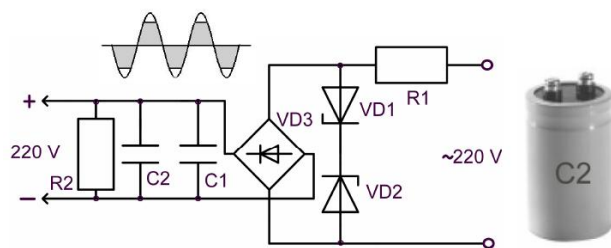

Fig. 2. The device for reserve feed of MPR at emergency mode with AC auxiliary voltage

In this device a capacitor of large capacity is designated, such as C2. The C1 auxiliary-not- electrolytic capacitor with capacity in some microfarads serves for smoothing pulsations on electrolytic capacitor C2. It is possible to include also in parallel to C1 one more ceramic capacitor with a capacity of some thousand picofarads, for protection of C2 against the high-frequency harmonics contained in mains AC voltage. A R1 (200 - 250 Ohm) resistor limits the charging current of C2 at a level near 1A. The same resistor also limits pulse currents proceeding through back-to-back connected Zener diodes VD1 and VD2. Resistor R2 has high resistance and serves to accelerate the discharging capacitor up to a safe volt-

age at switching-off of the auxiliary voltage. Zener diodes are intended for the maximal value voltage limits of capacitor C2 at a level of 240 V. Without such limitations on the device output voltage would reach a value of more than 300 V due to the difference between r.m.s. and peak values of voltage. That is undesirable both for MPR and for C2. The Zener diodes slices part of a voltage sinusoid in which amplitude exceeds 240 V, forming a voltage trapeze before rectifying. As powerful Zeners for rating voltage above 200 V are not at present on the market, it is necessary to use two series connected Zeners with dissipation power of 10 W and rating voltage of 120 V, as each of Zeners (VD1, DD2 - for example types 1N1810, 1N3008B, 1N2010, NTE 5223A, etc).

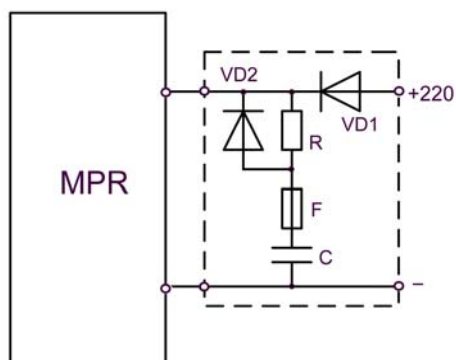

Fig. 3. The device for reserve feed of MPR at emergency mode with DC auxiliary voltage.

As further research of this type of situation clarified, the problem of maintenance of reliable feed MPR is relevant not only for substations with AC auxiliary voltage, but also for substations with DC voltage. Many situations where the main substation battery becomes switched-off from the DC bus bars are known. In this case nothing terrible occurs, as the voltage on the bus bar is supported by charger. However, if during this period an emergency mode occurs in a power network, the situation appears to be no better, since use of an AC auxiliary voltage as charger feeds from the same AC network. Usually an electrolytic capacitor with some hundreds of microfarads for smoothing voltage pulsations is included on the charger output. Since not only many MPRs, but also set of other consumers are connected to charger output it is abundantly clear that this capacity is not capable of supporting the necessary voltage level on the bus bars during the time required for proper operation of the MPRs. For maintenance of working capability of MPRs in these conditions it is possible to use the same technical solution with the individual storage capacitor connected in parallel to each MPR feeding circuit. Now the design of the device will be much easier, due to a cut- out from the circuit diagram of Zeners and rectifier bridge (Fig. 3). The resistor R (100 Ohm) is necessary for limiting of the charging current of the capacitor at switching-on auxiliary voltage with a fully discharged capacitor. Diode VD1 should be for a rated current of not less than 10 A. High capability quick blow fuse F (5 A/1500 A, 500 V) intended for protection both: feeding circuit of MPR and external DC circuit at damaging of the capacitor.

One more variant of the solution of this problem for substations with DC auxiliary voltage is to not use an individual capacitor for each MPR, but rather a special "supercapacitor" capable of feeding a complete relay protection system set together with conjugate electronic equipment within several seconds. Such supercapacitors are can already be found on the market under brand names such as: "supercapacitors", "ultracapacitors", "double-layer capacitors", and also "ionistors" (for Russian-speaking technical literature). There are electrochemical components intended for storage of electric energy. On specific capacity and speed of access to the reserved energy they occupy an intermediate position between large electrolytic capacitors and standard accumulator batteries, differing both from one and the others in their principle of action, based on redistribution of charges in electrolyte and their concentration on the border between the electrode and electrolyte. Today, supercapacitors are produced by many Western companies (Maxwell Technologies; NessCap; Cooper Bussmann; Epcos; etc.) and also some Russian enterprises (ESMA; ELIT; etc.). The capacity of modern supercapacitors reaches hundreds and even thousand of Farads, however the rated voltage of one element does not exceed, as a rule, 2.3 - 2.7 V. For higher voltage separate elements connecting among themselves in parallel and series as consistent units (Fig. 4).



Fig. 4. Internal design of high-voltage (ten voltages) supercapacitor, assembled from number of low-voltage elements

Unfortunately, supercapacitors are not so simply incorporated among themselves as ordinary capacitors, demand leveling resistors at series cells connection and special electronic circuits for alignment of currents at parallel cells connection. As a result, such units turn out to be rather "weighty", expensive and not so reliable (there could be enough damage to one of the internal auxiliary elements to cause failure of the entire unit). For example combined supercapacitor manufactured by the NessCap firm, with a capacity of 51 F and voltage of 340 V, weighs 384 kg! One unique company known to us which produces individual modules (that is not containing too many low-voltage cells inside) for high voltage, fig. 5, is the Canadian firm "Tavrma". Its ESCap90/300 type supercapacitor (see table below) approaches our purposes quite well.