



# Boundary effects in large deviation problems

I.A. Ignatyuk, Vadim A. Malyshev, V.V. Scherbakov

► **To cite this version:**

I.A. Ignatyuk, Vadim A. Malyshev, V.V. Scherbakov. Boundary effects in large deviation problems. [Research Report] RR-1999, INRIA. 1993. inria-00074673

**HAL Id: inria-00074673**

**<https://hal.inria.fr/inria-00074673>**

Submitted on 24 May 2006

**HAL** is a multi-disciplinary open access archive for the deposit and dissemination of scientific research documents, whether they are published or not. The documents may come from teaching and research institutions in France or abroad, or from public or private research centers.

L'archive ouverte pluridisciplinaire **HAL**, est destinée au dépôt et à la diffusion de documents scientifiques de niveau recherche, publiés ou non, émanant des établissements d'enseignement et de recherche français ou étrangers, des laboratoires publics ou privés.



INSTITUT NATIONAL DE RECHERCHE EN INFORMATIQUE ET EN AUTOMATIQUE

*Boundary Effects in  
Large Deviation Problems*

I.A. IGNATYUK  
V. MALYSHEV  
V.V. SCHERBAKOV

N° 1999

Juillet 1993

PROGRAMME 1

Architectures parallèles,  
bases de données,  
réseaux et systèmes distribués

*R*apport  
*de recherche*

1993

# Effets de bord dans les problèmes de grandes déviations

I.A.Ignatyuk \*    V.Malyshev †    V.V.Scherbakov\*

July 9, 1993

## Abstract

Nous obtenons des formules explicites pour les problèmes de grandes déviations sur  $Z_+^1$ ,  $Z_+^1 \times Z^\mu$ ,  $Z^\mu$  muni d'une discontinuité planaire, et sur  $Z_+^2$ . Ces résultats inattendus sont obtenus à l'aide de nouvelles méthodes probabilistes assez simples.

---

\*Postal address: Laboratory of Large Random Systems, Moscow State University, Moscow, 119899, Russia

†Postal address: I.N.R.I.A.- Domaine de Voluceau- Rocquencourt-B.P.105-78153, Le Chesnay Cedex, France

# Boundary Effects in Large Deviation Problems

I.A.Ignatyuk \*    V.Malyshev †    V.V.Scherbakov\*

July 12, 1993

## Abstract

We get explicit formulas for large deviation problems in  $Z_+^1$ ,  $Z_+^1 \times Z^\mu$ ,  $Z^\mu$  with a discontinuity along an hyperplane, and on  $Z_+^2$ . These quite unexpected results are obtained by using new simple probabilistic techniques.

---

\*Postal address: Laboratory of Large Random Systems, Moscow State University, Moscow, 119899, Russia

†Postal address: I.N.R.I.A.- Domaine de Voluceau- Rocquencourt-B.P.105-78153, Le Chesnay Cedex, France

# 1 General introduction.

Large deviation theory for Markov processes is now a well developed field with excellent expositions (see [7], [8], etc.) Nevertheless, this mainly concerns the cases where transition rates (or coefficients, for diffusion processes) vary continuously in space under appropriate scaling. We consider here some typical examples when there is a discontinuity with (generalised) reflection. We give the definition of (defined in [1]) deflected random walks  $S(t), t = 0, 1, \dots$  in  $Z_+^\nu$ , or more generally in  $Z_+^\nu \times Z^\mu$ . In the next sections we give separate definitions for all the examples we consider, so the reader can skip this introduction. Denote the points of  $Z_+^\nu$  by  $x = (n_1, \dots, n_\nu)$ . Let  $\Lambda \subset \{1, \dots, \nu\}$ . We denote by  $\Lambda$  also the face  $\{(n_1, \dots, n_\nu) : n_i > 0, i \in \Lambda; n_i = 0, i \notin \Lambda\}$ . Define discrete time homogeneous Markov chain with state space  $Z_+^\nu$  and transition probabilities  $p_{x,y}$ , satisfying the following maximal homogeneity condition :

$$p_{x,y} = p(\Lambda; y - x), x \in \Lambda \quad (1)$$

That is, the transition probabilities depend only on the face to which  $x$  belongs and also on the difference between the points.

We assume also boundedness of jumps :  $p_{x,y} \neq 0$  can occur only if for all  $i$  we have  $-1 \leq y_i - x_i \leq d$  for some  $d \geq 1$ . Note that it is an exercise to generalise our results to the case when  $d = \infty$  but all exponential moments exist.

The parameter space for these random walks is the direct product

$$\mathcal{P} = \times \mathcal{P}_\Lambda \quad (2)$$

(over all faces  $\Lambda$ ) of  $\mathcal{P}_\Lambda$ , where  $\mathcal{P}_\Lambda = \{p(\Lambda, \cdot)\}$  is the parameter space for the face  $\Lambda$ .

We consider large deviation problems for such random walks. Examples of such problems are the following:

- (i) asymptotics of  $\log P(S(N) = [xN]), N \rightarrow \infty$  for some  $x \in R_+^\nu$ ;
- (ii) logarithmic asymptotics of the stationary probabilities  $\pi([xN])$  for ergodic deflected random walks;

(iii) asymptotics of  $\log P(\sup_{i \leq N\tau} |S(i) - N\varphi(\frac{i}{N})| < \delta N)$  for some function  $\varphi(t) : [0, \tau] \rightarrow R_+^\nu$ .

We shall see that example (iii) is the most general and (i) and (ii) appear as corollaries from (iii). Moreover, we shall see that it is sufficient to consider piecewise linear functions  $\varphi(t) : [0, \tau] \rightarrow R_+^\nu$ .

There are important results concerning these problems ( see for example [2] and [3]). However, we provide here a new insight to them. First of all we try (via a simple probabilistic approach and new tricks) to get the results as explicitly as possible using our experience (see [1], [4], [5]) in studying deflected random walks in  $Z_+^\nu$ .

Secondly, we study an influence of the boundary parameters on the asymptotics. For example, we consider the following problems.

A. For which  $x$  does the limit

$$\lim_{N \rightarrow \infty} \frac{1}{N} \log \pi([Nx]) = l = l(x) \quad (3)$$

not depend on the boundary jumps ? More exactly, when does  $l(x)$  not depend on parameters  $\mathcal{P}_\Lambda, \Lambda \neq \{1, \dots, \nu\}$  ?

B. We study "critical surfaces" in  $\mathcal{P} \times \{x\}$ , where  $l$  is no more differentiable with respect to parameters,  $l$  is smooth outside these critical surfaces.

We compare earlier analytic results for a quarter plane (see [6]) with our results. But we have not revealed deep connections between the analytic approach (through complex spaces) and probabilistic approach (through real space).

Similar to stability problems (see [1]) the complexity of large deviation problem strongly depends on the codimension of boundaries, i.e. on  $\nu$ . Here we consider codimension 1 and 2. For larger codimensions our methods also work in many particular cases but we have no a complete picture at the present moment.

To make the paper readable for beginners in large deviations we included an introductory section 2.1.

## 2 Analytic methods.

## 2.1 Steepest descent and Legendre transform for sums of independent random variables.

In this subsection we give a brief introduction to the analytic methods for large deviation problems.

Let  $S(t), t = 0, 1, \dots$ , be a homogeneous random walk in  $Z^{\nu}$  with bounded jumps, starting from 0.

Consider  $S(N)$  as the sum of i.i.d. random variables :  $S(N) = \xi_1 + \dots + \xi_N$ .

Then we have

$$P(S(N) = [xN]) = \frac{1}{2\pi i} \int_{|z|=1} \frac{1}{z^{[xN]+1}} E z^{S(N)} dz \quad (4)$$

Put  $z = \exp \lambda$  and note that  $E z^{S(N)} = (E \exp(\lambda \xi))^N = \exp(NH(\lambda))$ , where

$$H(\lambda) = \log E \exp(\lambda \xi) \quad (5)$$

is the semiinvariant generating function. Rewriting the integral (3) as

$$\frac{1}{2\pi i} \int_{|z|=1} \exp(N(H(\lambda) - x\lambda)) \exp(-\lambda + \epsilon_N) dz, \quad (6)$$

where  $\epsilon_N = -[xN] + xN$ , we want to use the method of steepest descent for this integral (5) and so we have to look for the critical points of the function  $H(\lambda) - x\lambda$ . The function  $H(\lambda)$  is convex and analytic in the complex plane, so for  $z > 0$  the critical point  $\lambda_{cr} = \lambda(x)$  is unique or none and we can use the contour (when  $\lambda_{cr}$  exists)

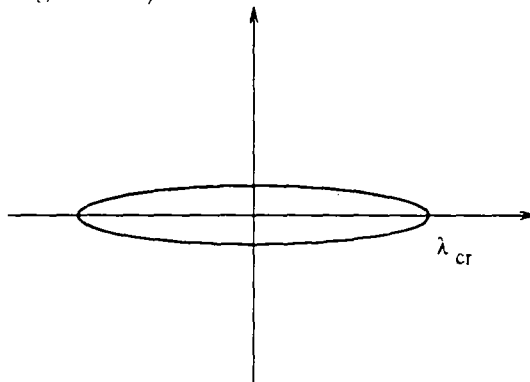

We are interested here only in the exponent in the integrand of (5):

$$L(x) = -H(\lambda(x)) + x\lambda(x) = \sup(-H(\lambda) + x\lambda)$$

which is called the Legendre transform of  $H(x)$ . So the method of steepest descent gives us the following result.

**Theorem 2.1.1**

$$\log P(S(N) = [xN]) \sim -L(x)N, \quad (7)$$

as  $N \rightarrow \infty$

Let uniformly bounded  $\xi_t$  be dependent but strongly mixing, for example assume them to be Gibbs with translation invariant two-point interaction

$$U = \sum_{t,s} V(t-s)\xi_t\xi_s$$

with exponential decrease. Then as it is well known the “partition function”  $E \exp(\lambda S(N))$ , which is the ratio of two partition functions

$$E \exp(\lambda S(N)) = \frac{\sum_{\{\xi\}} \exp(-U + \lambda \sum_{t=1}^N \xi_t)}{\sum_{\{\xi\}} \exp(-U)}$$

has the asymptotics

$$\log E \exp(\lambda S(N)) \sim N(H(U, \lambda) - H(U, 0)) + \text{const} + o(1)$$

where  $H(U, \lambda)$  is called the free energy of the “partition function” of the numerator. Moreover it is known to be analytic and convex for real  $\lambda$ . There are several methods (see [10], [11]) to prove all these assertions and calculate the free energy in one dimension: renormalisation group with cluster expansions, transfer matrix method etc. They are applicable for all  $\lambda$ . So the theorem 2.1.1 holds for this case as well. For Markov chains (or when the interaction has a finite radius, to get a Markov chain we can assume the radius equal 1 )

$$H(U, \lambda) = \rho_1(U, \lambda) \quad (8)$$

where  $\rho_1(U, \lambda)$  is the maximal eigenvalue of the (positive) transfer-matrix  $(p_{ij} \exp(\lambda(j-i)))$  where  $p_{ij}$  are the transition probabilities for the Markov chain  $\xi_t$ . Note that  $\rho_1(U, 0) = 1$ .



## 2.2 Analytic methods in a quarter plane.

In this subsection we formulate the main results of [6] on the asymptotic behaviour of stationary probabilities for random walks in the quarter plane in terms of zeros of some simple polynomial equations in the complex plane.

Denote points of  $Z_+^2$  by  $(k, l)$  and consider a discrete time homogeneous Markov chain with this state space. Let  $P((k, l) \rightarrow (k', l'))$  be its one step transition probabilities. Assume that they can be different from zero only if  $-1 \leq k' - k \leq d$  and  $-1 \leq l' - l \leq d$  for some  $d > 0$ . Also assume homogeneity conditions (putting  $i = k' - k, j = l' - l$ )

$$P((k, l) \rightarrow (k', l')) = \begin{cases} p_{i,j} & \text{if } k, l > 0 \\ p'_{i,j} & \text{if } l = 0, k > 0 \\ p''_{i,j} & \text{if } l > 0, k = 0 \\ p^0_{i,j} & \text{if } l = 0, k = 0. \end{cases}$$

We recall here the results of [6] where it was assumed also that

- (i)  $d = 1$ .
- (ii) inside the quarter plane only the transition probabilities  $p_{0,1}, p_{1,0}, p_{-1,0}, p_{0,-1}$  are different from zero.
- (iii) components of the inside mean jump vector

$$M = (M_1, M_2) = \left( \sum_{i,j} i p_{i,j}, \sum_{i,j} j p_{i,j} \right)$$

are negative, and

$$\sum_i p'_{i1} \neq 0, \sum_j p''_{1j} \neq 0$$

Assumption (ii) is not crucial for the applicability of the analytical methods but simplifies computations considerably. Besides the case (iii) there is also the case when only one of  $M_1, M_2$  is negative. This case can be considered similarly.

Introduce the polynomial generating functions

$$Q(x, y) = xy \left( 1 - \sum_{i,j} p_{i,j} x^i y^j \right),$$

$$q(x, y) = x \left( \sum_{i,j} p'_{i,j} x^i y^j - 1 \right).$$

$$q'(x, y) = y \left( \sum_{i,j} p''_{i,j} x^i y^j - 1 \right).$$

Consider the Riemann surface  $\mathcal{S}$  of the algebraic functions  $y(x)$  (or  $x(y)$ ) defined by the equation

$$Q(x, y) = 0$$

Let  $x(s), y(s)$  be meromorphic functions on  $\mathcal{S}$  defining the coverings of the  $x$ -plane and  $y$ -plane respectively of  $\mathcal{S}$ . We formulate here some results from [6]

1. There are exactly four branching points  $x_i$  of the algebraic function  $y(x)$  (or of  $x^{-1} : 0 < x_1 < x_2 < 1 < x_3 < x_4$ . Similarly for  $x(y)$ ).

2. We call  $S_r = \{s : x(s) \text{ and } y(s) \text{ are real}\}$  the set of real points of  $\mathcal{S}$ .  $S_r$  consists of two disjoint analytic closed curves homologous to one of the elements of the normal homology basis on  $\mathcal{S}$  (more exactly to the one different from  $x^{-1} (\{x : |x| = 1\})$ ). One of them, call it  $F_0$ , has the property that on it :  $x_2 \leq x(s) \leq x_3, y_2 \leq y(s) \leq y_3$ . Denote the other one by  $F_1$ .  $F_0$  has an ordered set of eight characteristic points  $s_0, \dots, s_7$ .

We show circles on the  $x$ -plane and on the  $y$ -plane : point  $s_0 = (1, 1)$  is indicated and the arrows show the further correspondence between the values of  $x(s_i)$  and  $y(s_i)$ .

$$x(s_7) = x_2, x(s_6) = x(s_0) = 1, x(s_5) = x(s_1) = \sqrt{\frac{p_{0,-1}}{p_{0,1}}}, x(s_4) = x(s_2) = \frac{p_{0,-1}}{p_{0,1}}, x(s_3) = x_3$$

$$y(s_7) = y_2, y(s_6) = y(s_0) = 1, y(s_5) = y(s_1) = \sqrt{\frac{p_{-1,0}}{p_{1,0}}}, y(s_4) = y(s_2) = \frac{p_{-1,0}}{p_{1,0}}, y(s_3) = y_3$$

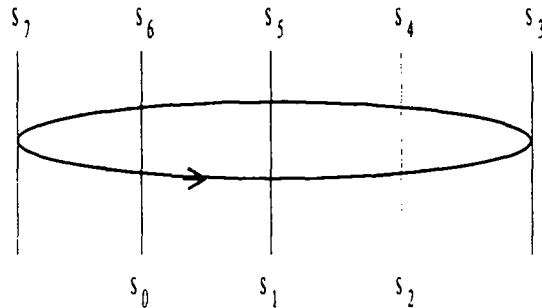

3. The function  $\phi_\gamma(s) = |xy^\gamma|, 0 \leq \gamma < 1$ , has (in the domain  $\phi_\gamma^{-1}((0, \infty))$ ) four nondegenerate critical points  $s_i(\gamma), i = 1, \dots, 4$ . Any  $s_i(\gamma)$  continuously depends on  $\gamma$  that uniquely defines these points if we agree that  $x(s_i(0)) = x_i$ .

Moreover,  $s_2(\gamma), s_3(\gamma) \in F_0$  and  $x_i(\gamma) = x(s_i(\gamma)), y_i(\gamma) = y(s_i(\gamma))$  are real. For  $\gamma = 1$ , one can put  $s_1(1) = 0, s_4(1) = \infty$ , and for the critical points  $s_2(1), s_3(1)$  the above assertions hold. Equations defining these critical points are

$$Q(x, y) = 0, \quad (9)$$

and

$$\frac{y}{\gamma x} = \frac{\frac{d}{dx}Q(x, y)}{\frac{d}{dy}Q(x, y)} \quad (10)$$

We have also

$$1 < x_3(1) < x_3(\gamma) < x_3(0) = x_3$$

$$y_3(0) = \sqrt{\frac{p_{0,-1}}{p_{0,1}}} < y_3(\gamma) < y_3(\gamma).$$

It appears that the asymptotics of the stationary probabilities is defined either by the critical points  $s_3(\gamma)$  or by the poles in the points  $s_0(\gamma)$  and  $s'_0(\gamma)$  where correspondingly  $q(\zeta s_0) = 0$  or  $q'(\eta s'_0) = 0$ . The Galois automorphisms  $\zeta$  and  $\eta$  on  $S$  are defined by

$$\zeta(x, y) = \left(x, \frac{p_{0,-1}}{p_{0,1}y}\right), \quad \eta(x, y) = \left(\frac{p_{-1,0}}{p_{1,0}x}, y\right)$$

In the parameter space  $\mathcal{P} \times \{\gamma : 0 < \gamma \leq 1\}$  define the subsets

$$\mathcal{P}_{--} = \left\{ (p, \gamma) : q\left(x_3(\gamma), \frac{p_{0,-1}}{p_{0,1}y_3(\gamma)}\right) \leq 0, q'\left(\frac{p_{-1,0}}{p_{1,0}x_3(\gamma)}, y_3(\gamma)\right) \leq 0 \right\},$$

$$\mathcal{P}_{+-} = \left\{ (p, \gamma) : q\left(x_3(\gamma), \frac{p_{0,-1}}{p_{0,1}y_3(\gamma)}\right) > 0, q'\left(\frac{p_{-1,0}}{p_{1,0}x_3(\gamma)}, y_3(\gamma)\right) \leq 0 \right\}$$

and  $\mathcal{P}_{-+}, \mathcal{P}_{++}$  correspondingly.

**Theorem 2.2.1** (See [6]). Let  $m, n \rightarrow \infty$  so that  $\frac{n}{m} = \gamma$ . Then in  $\mathcal{P}_{--}$  we have

$$\pi(m, n) \sim \frac{\text{const}}{\sqrt{m}} (x_3(\gamma)y_3(\gamma))^{-m}$$

Otherwise

$$\pi(m, n) \sim \begin{cases} \text{const}(x_0(\gamma)y_0^\gamma(\gamma))^{-m} & \text{in } \mathcal{P}_{-+} \\ \text{const}(x_5(\gamma)y_5^\gamma(\gamma))^{-m} & \text{in } \mathcal{P}_{+-} \\ \text{const}(x_0(\gamma)y_0^\gamma(\gamma))^{-m} + \text{const}(x_5(\gamma)y_5^\gamma(\gamma))^{-m} & \text{in } \mathcal{P}_{++} \end{cases}$$

where  $1 < x_0(\gamma) < x_3(\gamma)$ ,  $1 < y_0(\gamma) < \frac{p_0-1}{p_{0,1}y_3(\gamma)}$  and  $1 < x_5(\gamma) < \frac{p-1,0}{p_{1,0}x_3(\gamma)}$ ,  $1 < y_5(\gamma) < y_3(\gamma)$  are defined from the systems

$$Q(x, y) = 0, q(x, \zeta y) = 0 \quad (11)$$

$$Q(x, y) = 0, q'(\eta x, y) = 0 \quad (12)$$

correspondingly.

### 3 Probabilistic method.

#### 3.1 General definitions.

The main goal of this paper is to prove the large deviation principle and to find explicitly the action functionals for the class of random walks defined below. This large deviation principle will be used to get asymptotics of the stationary probabilities in a quarter plane.

**Random walks** We consider the random walk  $S_t(x)$  in  $Z_+^\nu \times Z^\mu$  starting at the point  $x$ . Let  $\Lambda \subset \{1, \dots, \nu\}$ . We denote by  $\Lambda$  also the face  $\{(x_1, \dots, x_\nu) : x_i > 0, i \in \Lambda; x_i = 0, i \notin \Lambda\} \times R^\mu \subset R_+^\nu \times R^\mu$ . Define discrete time homogeneous Markov chain with the state space  $Z_+^\nu \times Z^\mu$  and transition probabilities  $p_{x,y}$ , satisfying the following maximal homogeneity condition :

$$p_{x,y} = p(\Lambda; y - x), x \in \Lambda \quad (13)$$

That is, the transition probabilities depend only on the face to which  $x$  belongs and on the difference between the points.

We assume also boundedness of jumps :  $p_{x,y} \neq 0$  can occur only if for all  $i = 1, \dots, \nu$  we have for the  $R_+^\nu$ -components :  $-1 \leq y_i - x_i \leq d$  and for  $R^\mu$ -components  $-d \leq y_i - x_i \leq d$  for some  $d \geq 1$ .

**Large deviation principle** For any  $\tau \in R_+$  consider the set  $C([0, \tau], R_+^\nu \times R^\mu)$  of all continuous functions  $\varphi : [0, \tau] \rightarrow R_+^\nu \times R^\mu$ . Let be given functionals  $\mathcal{L}_\tau$ , mapping the space  $C([0, \tau], R_+^\nu \times R^\mu)$  into  $[0, +\infty]$ . Consider for any  $s \geq 0$  and for any  $x \in R_+^\nu \times R^\mu$  the set

$$\Phi_{x,\tau}(s) = \{\varphi \in C([0, \tau], R_+^\nu \times R^\mu) : \varphi(0) = x \text{ and } \mathcal{L}_\tau(\varphi) \leq s\}$$

**Definition 3.1.1** We say that the random walk  $S_t$  satisfies the large deviation principle with action functionals  $\mathcal{L}_\tau$  if for any  $\tau \geq 0$  and for any  $x \in R_+^\nu \times R^\mu$  the following three conditions hold.

(i) (compactness .) For any  $s \geq 0$  the set  $\Phi_{x,\tau}(s)$  is compact.

(ii) (large deviation lower bound.) For any  $\delta > 0$ ,  $s_0 > 0$ ,  $\delta' > 0$  there exists  $N_0$  such that for any  $N > N_0$ ,  $\varphi \in \Phi_{x,\tau}(s_0)$ , the following estimate holds

$$P\left\{ \sup_{t=0, \dots, [N\tau]} \left| \frac{1}{N} S_t([Nx]) - \varphi\left(\frac{t}{N}\right) \right| < \delta \right\} \geq \exp\{-\delta'N - N\mathcal{L}_\tau(\varphi)\} \quad (14)$$

(iii) (large deviation upper bound.) For any  $\delta > 0$ ,  $\delta' > 0$ ,  $s_0 > 0$ , there exists  $N_0$  such that for any  $N > N_0$ ,  $0 < s < s_0$  the following estimate holds

$$\begin{aligned} P\left\{ \sup_{t=0, \dots, [N\tau]} \left| \frac{1}{N} S_t([Nx]) - \varphi\left(\frac{t}{N}\right) \right| \geq \delta \text{ for any } \varphi \in \Phi_{x,\tau}(s) \right\} \leq \\ \leq \exp\{\delta'N - Ns\} \end{aligned} \quad (15)$$

Let us note that, due to the boundedness of the jumps of the random walk  $S_t$ , for any path  $\varphi \in C([0, \tau], R_+^\nu \times R^\mu)$  (and even for discontinuous  $\varphi$ ) for which there exist  $0 < t < t' < \tau$  such that

$$|\varphi(t) - \varphi(t')| > d(t' - t)$$

we have

$$P\left\{ \sup_{t=0, \dots, [N\tau]} \left| \frac{1}{N} S_t([Nx]) - \varphi\left(\frac{t}{N}\right) \right| < \delta \right\} = 0$$

for sufficiently small  $\delta > 0$  and sufficiently large  $N$ , and consequently if the random walk satisfies the large deviation principle with the action functionals  $\mathcal{L}_\tau$  then for such  $\varphi$

$$\mathcal{L}_\tau(\varphi) = +\infty$$

### Lagrangians

In the next sections we shall prove the large deviation principle for linear paths (in a stronger version, see conditions (ii) and (iii) of Theorem 3.1.1). We shall find also explicit expressions of the action functional for linear paths. We shall see that it will have the following form.

Let for any face  $\Lambda$  of  $R^\nu$  a function

$$L(\cdot; \Lambda) : R^k \times R^\mu \rightarrow R_+ \cup \{+\infty\}$$

be defined, where  $k$  is the dimension of  $\Lambda$ . Define the lagrangian, i.e. the function  $L : (R_+^\nu \times R^\mu) \times R^{\nu+\mu} \rightarrow R_+ \cup \{+\infty\}$  such that for all  $\Lambda$  and for all  $x \in \Lambda$

$$L(x, v) = L(v_\Lambda; \Lambda),$$

where  $v_\Lambda$  is the projection of  $v$  onto  $\Lambda$ .

For a linear path  $\varphi : [0, \tau] \rightarrow R_+^\nu \times R^\mu$  define its speed vector

$$v(\varphi) = \frac{\varphi(\tau) - \varphi(0)}{\tau}$$

and the face  $\Lambda = \Lambda(\varphi)$  to which this path belongs. Then we shall prove that  $\mathcal{L}_\tau(\varphi) = \tau L_{\Lambda(\varphi)}(v(\varphi))$ . In other words to find the action functional we should find the constants  $L(\Lambda, v)$ .

To satisfy condition (iv) of theorem 3.1.1 we should, for any  $\tau > 0$ , define the functional

$$\mathcal{L}_\tau(\varphi) = \int_0^\tau L(\varphi(t), \dot{\varphi}(t)) dt,$$

if  $\varphi$  is absolutely continuous, and

$$\mathcal{L}_\tau(\varphi) = +\infty$$

otherwise. Then from nice properties of the functions  $L(\Lambda, v)$  the conditions (i) and (iv) of theorem 3.1.1 will follow.

**From linear to arbitrary paths**

**Theorem 3.1.1** *Let for the random walk  $S_t$  the functionals  $\mathcal{L}_\tau$  be given such that for any  $\tau > 0$  the following conditions are satisfied:*

(i) *the functionals  $\mathcal{L}_\tau$  are lower semicontinuous.*

(ii) *for any  $\delta > 0$ ,  $\delta' > 0$  one can find  $\sigma > 0$  such that for any  $x, y \in R_+^\nu \times R^\mu$  such that  $|x - y| < \sigma$  and for any linear path  $\varphi \in \Phi_{x,\tau}$  the following estimate holds*

$$P\left\{ \sup_{t=0, \dots, [N\tau]} \left| \frac{1}{N} S_t([Ny]) - \varphi\left(\frac{t}{N}\right) \right| < \delta \right\} \geq \exp\{-\delta'N - N\mathcal{L}_\tau(\varphi)\} \quad (16)$$

*for all sufficiently large  $N$ .*

(iii) *for any  $\delta' > 0$  one can find  $\delta > 0$ ,  $\sigma > 0$  such that for any  $x, y \in R_+^\nu \times R^\mu$  such that  $|x - y| < \sigma$  and for any linear path  $\varphi \in \Phi_{x,\tau}$  the following estimate holds*

$$P\left\{ \sup_{t=0, \dots, [N\tau]} \left| \frac{1}{N} S_t([Ny]) - \varphi\left(\frac{t}{N}\right) \right| < \delta \right\} \leq \exp\{+\delta'N - N\mathcal{L}_\tau(\varphi)\} \quad (17)$$

*for all sufficiently large  $N$ .*

(iv) *for any  $x \in R_+^\nu \times R^\mu$ ,  $\varphi \in \Phi_{x,\tau}$  and for any  $\epsilon > 0$  there exists a piecewise linear path  $\tilde{\varphi} \in \Phi_{x,\tau}$  such that*

$$\sup_{0 \leq t \leq \tau} |\varphi(t) - \tilde{\varphi}(t)| < \epsilon \text{ and } |\mathcal{L}_\tau(\varphi) - \mathcal{L}_\tau(\tilde{\varphi})| < \epsilon$$

*Then the random walk satisfies the large deviation principle with the action functionals  $\mathcal{L}_\tau$ .*

**Proof.** Denote by  $\Phi_{x,\tau}$  the set of all continuous paths  $\varphi : [0, \tau] \rightarrow R_+^\nu \times R^\mu$  for which  $\mathcal{L}_\tau(\varphi) < \infty$ . Since for any  $\varphi \in \Phi_{x,\tau}$

$$\sup_{0 \leq t < t' \leq \tau} \frac{|\varphi(t) - \varphi(t')|}{t' - t} \leq d$$

then the set  $\Phi_{x,\tau}$  is relatively compact. So if the for any  $\tau > 0$  the functional  $\mathcal{L}_\tau$  is lower semicontinuous then the sets  $\Phi_{x,\tau}(s)$  are compact.

To get large deviations bounds we go first from linear paths to piecewise linear and then to arbitrary paths.

For any piecewise linear path  $\varphi : [0, \tau] \rightarrow R_+^\nu \times R^\mu$  consider its linear pieces  $\varphi_1, \dots, \varphi_k$ :

let  $0 = \tau_0 < \tau_1 < \dots < \tau_{k-1} < \tau_k = \tau$  and let  $\varphi$  be linear on each interval  $(\tau_j, \tau_{j+1})$ ,  $j = 0, \dots, k-1$  then

$$\varphi_j(t) = \varphi(t + \tau_j), \quad 0 \leq t \leq \tau_{j+1} - \tau_j$$

**Lemma 3.1.1** *Let for any  $\tau \geq 0$ ,  $x \in R_+^{\nu} \times R^{\mu}$  and for any linear path  $\varphi \in \Phi_{x,\tau}$  the following two conditions hold:*

(i) *for any  $\delta > 0$ ,  $\delta' > 0$  one can find  $\sigma > 0$  such that for any  $y \in R_+^{\nu} \times R^{\mu}$  such that  $|x - y| < \sigma$  the following estimate holds*

$$P\left\{ \sup_{t=0, \dots, [N\tau]} \left| \frac{1}{N} S_t([Ny]) - \varphi\left(\frac{t}{N}\right) \right| < \delta \right\} \geq \exp\{-\delta'N - N\mathcal{L}_{\tau}(\varphi)\}$$

for all sufficiently large  $N$ .

(ii) *for any  $\delta' > 0$  one can find  $\delta > 0$ ,  $\sigma > 0$  such that for any  $y \in R_+^{\nu} \times R^{\mu}$  such that  $|x - y| < \sigma$  the following estimate holds*

$$P\left\{ \sup_{t=0, \dots, [N\tau]} \left| \frac{1}{N} S_t([Ny]) - \varphi\left(\frac{t}{N}\right) \right| < \delta \right\} \leq \exp\{+\delta'N - N\mathcal{L}_{\tau}(\varphi)\}$$

for all sufficiently large  $N$ .

Then for any  $\tau > 0$  the following conclusions hold

(ii) *for any  $\delta > 0$ ,  $\delta' > 0$  one can find  $\sigma > 0$  such that for any  $x, y \in R_+^{\nu} \times R^{\mu}$  such that  $|x - y| < \sigma$  and for any piecewise linear path  $\varphi \in \Phi_{x,\tau}$  the following estimate holds*

$$P\left\{ \sup_{t=0, \dots, [N\tau]} \left| \frac{1}{N} S_t([Ny]) - \varphi\left(\frac{t}{N}\right) \right| < \delta \right\} \geq \exp\{-\delta'N - N\mathcal{L}_{\tau}(\varphi)\} \quad (18)$$

for all sufficiently large  $N$

(iii) *for any  $\delta' > 0$  one can find  $\delta > 0$ ,  $\sigma > 0$  such that for any  $x, y \in R_+^{\nu} \times R^{\mu}$  such that  $|x - y| < \sigma$  and for any piecewise linear path  $\varphi \in \Phi_{x,\tau}$  the following estimate holds*

$$P\left\{ \sup_{t=0, \dots, [N\tau]} \left| \frac{1}{N} S_t([Ny]) - \varphi\left(\frac{t}{N}\right) \right| < \delta \right\} \leq \exp\{+\delta'N - N\mathcal{L}_{\tau}(\varphi)\} \quad (19)$$

for all sufficiently large  $N$

with the action functional

$$\mathcal{L}_{\tau}(\varphi) = \sum_{j=1}^k \mathcal{L}_{\tau_{j+1}-\tau_j}(\varphi_j)$$

where  $\varphi_1, \dots, \varphi_k$  are the linear pieces of  $\varphi$ .



One can easily prove this lemma using the induction with respect to the number of linear pieces.

■

**Lemma 3.1.2** *Let for any  $\tau \geq 0, x \in R_+^\nu \times R^\mu$  for any  $\varphi \in \Phi_{x,\tau}$  and for any  $\epsilon > 0$  there exists a piecewise linear path  $\check{\varphi} \in \Phi_{x,\tau}$  such that*

$$\sup_{0 \leq t \leq \tau} |\varphi(t) - \check{\varphi}(t)| < \epsilon \text{ and } |\mathcal{L}_\tau(\varphi) - \mathcal{L}_\tau(\check{\varphi})| < \epsilon$$

and let for any  $\tau > 0$  and for any piecewise linear path  $\varphi \in \Phi_{x,\tau}$  lower large deviation bound (18) and upper large deviation bound (19) hold.

Then lower large deviation bound (14) and upper large deviation bound (15) hold.

**Proof.** Let  $x \in R_+^\nu \times R^\mu$ ,  $\varphi \in \Phi_\tau$ ,  $\delta > 0, \delta' > 0$  be fixed. Choose a piecewise linear path  $\check{\varphi} \in \Phi_{x,\tau}$  such that

$$\sup_{0 \leq t \leq \tau} |\varphi(t) - \check{\varphi}(t)| < \frac{\delta}{2} \text{ and } |\mathcal{L}_\tau(\varphi) - \mathcal{L}_\tau(\check{\varphi})| < \frac{\delta'}{2}$$

Then

$$\begin{aligned} & \frac{1}{N} \log P \left\{ \sup_{t=0, \dots, [N\tau]} \left| \frac{S_t([xN])}{N} - \varphi\left(\frac{t}{N}\right) \right| < \delta \right\} \\ & \geq \frac{1}{N} \log P \left\{ \sup_{t=0, \dots, [N\tau]} \left| \frac{S_t([xN])}{N} - \check{\varphi}\left(\frac{t}{N}\right) \right| < \frac{\delta}{2} \right\} \end{aligned}$$

and so to prove (ii) one should prove (ii)'.

Consider the upper bound. From compactness of the set  $\Phi_{x,\tau}$  it follows that for any  $s > 0, \delta > 0, \delta > \sigma > 0$  one can find finite number of paths

$$\varphi_1, \dots, \varphi_k \in \Phi_{x,\tau} \setminus \Phi_{x,\tau}(s)$$

such that

$$\begin{aligned} & \left\{ \sup_{t=0, \dots, [N\tau]} \left| \frac{S_t([xN])}{N} - \varphi\left(\frac{t}{N}\right) \right| > \delta \text{ for any } \varphi \in \Phi_\tau(s) \right\} \subseteq \\ & \subseteq \bigcup_{j=1}^k \left\{ \sup_{t=0, \dots, [N\tau]} \left| \frac{S_t([xN])}{N} - \varphi_j\left(\frac{t}{N}\right) \right| < \sigma \right\} \end{aligned}$$

Moreover, as for each  $\varphi \in \Phi_{x,\tau}$  and any  $\epsilon > 0$  one can find a piecewise linear path  $\tilde{\varphi} \in \Phi_{x,\tau}$  such that

$$\sup_{0 \leq t \leq \tau} |\varphi(t) - \tilde{\varphi}(t)| < \frac{\delta}{2} \text{ and } |\mathcal{L}_\tau(\varphi) - \mathcal{L}_\tau(\tilde{\varphi})| < \frac{\delta'}{2}$$

then the paths  $\varphi_1, \dots, \varphi_k \in \Phi_{x,\tau} \setminus \Phi_{x,\tau}(s)$  can be chosen to be piecewise linear.

In other words for any  $s > 0, \delta > 0, \delta' > 0$  one can find a finite number of piecewise linear paths  $\varphi_1, \dots, \varphi_k \in \Phi_{x,\tau} \setminus \Phi_{x,\tau}(s)$  such that

$$\begin{aligned} P\left\{ \sup_{t=0, \dots, [N\tau]} \left| \frac{S_t([\varphi(0)N])}{N} - \varphi\left(\frac{t}{N}\right) \right| > \delta \text{ for any } \varphi \in \Phi_\tau(s) \right\} &\leq \\ &\leq \sum_{j=1}^k P\left\{ \sup_{t=0, \dots, [N\tau]} \left| \frac{S_t([N\varphi_j(0)])}{N} \right| < \sigma \right\} \end{aligned}$$

So, (iii) follows from (iii)'. Lemma 3.1.2 is thus proved.

■

Theorem 3.1.1 is proved.

### 3.2 One-dimensional random walk.

Consider a random walk in  $Z_+^1$  with transition probabilities  $p_{ij}, i, j \in Z_+^1$  such that

$$p_{ij} = p_{j-i} \text{ for all } i > 0, j \in Z_+^1 \quad (20)$$

$$p_{ij} = 0 \text{ if either } -1 > j - i \text{ or } j - i > d \text{ for some finite } d \geq 1 \quad (21)$$

Note that there are only two constants  $L_\emptyset = L(v, \emptyset)$  and  $L(v) = L(v, \{1\})$  to be determined. The second one  $L(v)$  coincides with the corresponding constant for the homogeneous random walk on  $Z$  with transition probabilities  $p_{j-i}$  and is defined below. The first one,  $L_\emptyset$ , is zero for recurrent random walks, i.e. when the mean drift  $M = \sum_i i p_i \leq 0$ .

More interesting is the case when the random walk is transient (i.e. when the mean drift  $M = \sum_i i p_i > 0$ ). In this case  $L_\emptyset$  undergoes a kind of phase

transition with respect to change of parameters. We study this case in the rest of this section.

Assume the initial random walk defined on the probability space  $(\Omega, \Sigma, P)$ . In the sequel we use the following family of random walks  $S_t^\alpha, t \in Z_+, \alpha \in R$ , with transition probabilities

$$p_{ij}^\alpha = \frac{p_{ij} e^{\alpha(j-i)}}{\sum_j p_{ij} e^{\alpha(j-i)}}, p_{ij}^0 = p_{ij}$$

We can define these random walks on the space  $(\Omega, \Sigma)$  and shall denote the corresponding distributions and expectations by  $P_\alpha, E_\alpha$  and the random walk itself by  $S_t^\alpha$ . Let

$$H_i(\alpha) = \log \sum_j p_{ij} e^{\alpha(j-i)}.$$

Then  $H_i(\alpha) = H_1(\alpha)$  for all  $i > 0$ . Note that

$$M_i(\alpha) = \frac{d}{d\alpha} H_i(\alpha)$$

is the mean drift for  $S_t^\alpha$  from the point  $i$ , and

$$D_i(\alpha) = \frac{d^2}{d\alpha^2} H_i(\alpha)$$

is the variance.

Now we can define the function  $L(\cdot)$ . It is the Legendre transform of the function  $H_1$ .

The graphs of  $H_1(\alpha)$  and  $H_0(\alpha)$  can either intersect each other on the negative  $\alpha$ -axis (case 2) or not (case 1)

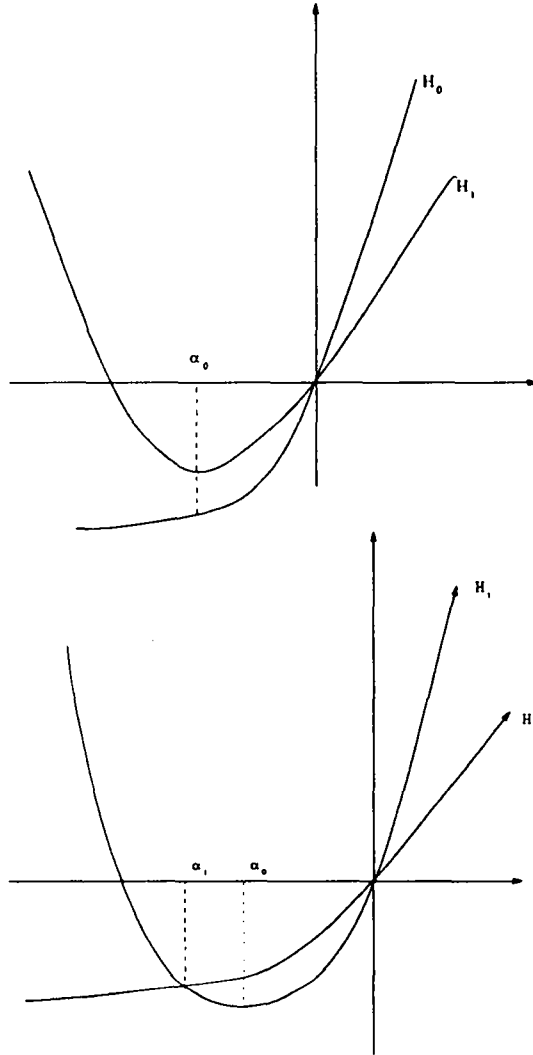

Here  $\alpha_0$  is such that  $H_1(\alpha_0) = \min_{\alpha} H_1(\alpha)$ . In case 2, i.e. when

$$H_0(\alpha_0) > H_1(\alpha_0),$$

there exists  $\alpha_1 \in \mathbb{R}$  such that

$$H_0(\alpha_1) = H_1(\alpha_1) \text{ and } \frac{d}{d\alpha} H_1(\alpha_1) < 0$$

**Theorem 3.2.1** *The large deviation principle holds for our random walk with the action functionals defined by the constant*

$$L_\emptyset = \begin{cases} H_1(\alpha_0) & \text{if } H_0(\alpha_0) \leq H_1(\alpha_0) \\ H_1(\alpha_1) & \text{if } H_0(\alpha_0) > H_1(\alpha_0) \end{cases}$$

**Proof.** Choose  $\delta > 0$  sufficiently small and let  $|x| < \frac{\delta}{2}$ . Consider the random walk  $S_t$  starting at the point  $[xN]$ . Denote  $A_{N\delta} = \{ \sup_{t=0, \dots, [N\tau]} S_t \leq N\delta \}$ . Then

$$P_0(A_{N\delta}) = E_0 I_{A_{N\delta}} \exp\{-\alpha S_{[N\tau]} + \sum_{t=0}^{[N\tau]-1} H_{S_t}(\alpha)\}$$

where  $I_{A_{N\delta}}$  is the indicator of  $A_{N\delta}$ .

Case 2. Putting  $\alpha = \alpha_1$  we get the lower bound

$$\begin{aligned} P_0(A_{N\delta}) &= E_{\alpha_1} I_{A_{N\delta}} \exp\{-\alpha_1 S_{[N\tau]} + [N\tau]H_1(\alpha_1)\} \\ &\geq \exp\{-|\alpha_1| \delta N + [N\tau]H_1(\alpha_1)\} E_{\alpha_1} I_{A_{N\delta}} \end{aligned} \quad (22)$$

Note that

$$E_{\alpha_1}[S_{t+1} - S_t \mid S_t = i] = M_i(\alpha_1) < 0, \quad (23)$$

and thus the random walk  $S_t^{\alpha_1}$  is ergodic, and

$$E_{\alpha_1} I_{A_{N\delta}} \rightarrow 1 \text{ as } N \rightarrow \infty \quad (24)$$

From (22) and (24) we get the lower bound.

In case 2 the upper bound follows from

$$P_0(A_{N\delta}) = E_{\alpha_1} I_{A_{N\delta}} \exp\{-\alpha_1 S_{[N\tau]} + [N\tau]H_1(\alpha_1)\} \leq \exp\{[N\tau]H_1(\alpha_1) + |\alpha_1| \delta N\} \quad (25)$$

Case 1.

The upper bound is again trivial

$$\begin{aligned}
P_0(A_{N\delta}) &= E_{\alpha_1} I_{A_{N\delta}} \exp\{-\alpha_0 S_{[N\tau]} + \sum_{t=0}^{[N\tau]-1} H_{S(t)}(\alpha_0)\} \\
&\leq \exp\{[N\tau]H_1(\alpha_0) + |\alpha_0| \delta N\}
\end{aligned} \tag{26}$$

To get the lower bound consider the event

$$B_{N\delta} = A_{N\delta} \cap \{S_t \neq 0 \text{ for } t = 0, \dots, [N\tau]\}$$

Then

$$\begin{aligned}
P_0(A_{N\delta}) &\geq P_0(B_{N\delta}) = E_{\alpha_1} I_{B_{N\delta}} \exp\{-\alpha_0 S_{[N\tau]} + \sum_{t=0}^{[N\tau]-1} H_{S_t}(\alpha_0)\} \\
&\geq \text{const} \exp\{-|\alpha_0| \delta N + N\tau H_1(\alpha_0)\} E_{\alpha_1} I_{B_{N\delta}}
\end{aligned}$$

But due to

$$E_{\alpha_0}\{S_{t+1} - S_t \mid S_t = i\} = M_i(\alpha_0) = 0, i > 0.$$

it is easy to show that for some constant  $\gamma > 0$

$$E_{\alpha_0} I_{B_{N\delta}} \geq \gamma \exp\{-\delta' N\}$$

**Remark 1** *The surface  $\mathcal{R} = \{H_1(\alpha_0) = H_0(\alpha_0)\}$  is called a Reynolds surface separating the two phases. The domain of parameters, where  $L_\theta$  does not depend on the parameters  $p_{0j}$ , defines phase 1. Phase 2 is when  $L_\theta$  depends on the parameters  $p_{0j}$ .  $L_\theta$  depends continuously on the parameters but in general it is not differentiable at the points of  $\mathcal{R}$ .*

### 3.3 Random walk in $Z_+^1 \times Z^\mu$

Consider a random walk  $S_t(i, x)$  in  $Z_+^1 \times Z^\mu$  starting at the point  $(i, x)$  and having the following transition probabilities  $p((i, x) \rightarrow (j, y)) = p_{i,j}(x, y)$ ,  $i, j \in Z_+^1$ ,  $x, y \in Z^\mu$ . We shall assume that

$\mathcal{A}_1$ :

(i) (boundedness of jumps)

$p_{i,j}(x, y) = 0$ , if either  $j - i < -1$ , or  $\max\{|i - j|, |x - y|\} > d$ .

for some fixed  $d > 0$ .

(ii) (homogeneity)

$$p_{i,j}(x, y) = p_{1, j-i+1}(y - x) \text{ for any } i > 0, j \in Z_+^1, x, y \in Z^\mu,$$

$$p_{0,j}(x, y) = p_{0,j}(y - x) \text{ for any } j \in Z_+^1, x, y \in Z^\mu,$$

(iii) the induced Markov chain with the set of states  $Z_+^1$  and transition probabilities

$$p_{i,j} = \sum_{y \in Z^\mu} p_{i,j}(y), \quad i, j \in Z_+^1$$

is irreducible and aperiodic.

Consider

$$H_i(\alpha, \beta) = \log \left\{ \sum_{y, j} p_{i,j}(y) \exp\{\alpha(j - i) + \beta y\} \right\}$$

$i \in Z_+^1, \alpha \in R, \beta \in R^\mu$ .

Due to the homogeneity assumption

$$H_i(\alpha, \beta) = H_1(\alpha, \beta)$$

for any  $i > 0$ . Denote by  $\partial_\alpha, \partial_\beta$  the partial derivatives with respect to  $\alpha$  and  $\beta$  correspondingly. Here  $\partial_\beta = (\partial_{\beta_1}, \dots, \partial_{\beta_\mu})$ . We shall assume that jacobians of  $H_0$  and  $H_1$  are nowhere zero:

for any  $\alpha, \beta$

$$\det \begin{pmatrix} \frac{\partial^2}{(\partial \alpha)^2} H_0(\alpha, \beta) & \frac{\partial^2}{\partial \alpha \partial \beta} H_0(\alpha, \beta) \\ \frac{\partial^2}{\partial \alpha \partial \beta} H_0(\alpha, \beta) & \frac{\partial^2}{(\partial \beta)^2} H_0(\alpha, \beta) \end{pmatrix} \neq 0$$

and

$$\det \begin{pmatrix} \frac{\partial^2}{(\partial \alpha)^2} H_1(\alpha, \beta) & \frac{\partial^2}{\partial \alpha \partial \beta} H_1(\alpha, \beta) \\ \frac{\partial^2}{\partial \alpha \partial \beta} H_1(\alpha, \beta) & \frac{\partial^2}{(\partial \beta)^2} H_1(\alpha, \beta) \end{pmatrix} \neq 0.$$

Let us consider the equations

$$\partial_\alpha H_1(\alpha, \beta) = 0 \tag{27}$$

$$H_0(\alpha, \beta) = H_1(\alpha, \beta) \quad (28)$$

One can easily show that for any  $\beta \in R^u$  there exists a unique  $\alpha_0(\beta)$  for which ( 27) holds. Let us note that for any  $\beta$  for which

$$H_1(\alpha_0(\beta), \beta) < H_0(\alpha_0(\beta), \beta)$$

there exists the unique  $\alpha_1(\beta)$  for which ( 28 ) holds and

$$\partial_\alpha H_1(\alpha, \beta) < 0. \quad (29)$$

Consider the following function

$$\alpha(\beta) = \begin{cases} \alpha_0(\beta) & \text{if } H_1(\alpha_0(\beta), \beta) \geq H_0(\alpha_0(\beta), \beta) \\ \alpha_1(\beta) & \text{if } H_1(\alpha_0(\beta), \beta) < H_0(\alpha_0(\beta), \beta) \end{cases}$$

**Lemma 3.3.1** *The function  $\mathcal{H}(\beta) = H_1(\alpha(\beta), \beta)$  is convex and it has continuous first derivatives.*

**Proof.** Consider the sets

$$\mathcal{C}_0 = \{\beta \in R^u : H_0(\alpha_0(\beta), \beta) \leq H_1(\alpha_0(\beta), \beta)\}$$

$$\mathcal{C}_1 = \{\beta \in R^u : H_0(\alpha_0(\beta), \beta) > H_1(\alpha_0(\beta), \beta)\}$$

It is easy to see that the function  $H_1(\alpha_0(\beta), \beta)$  is convex and it has a continuous first derivatives. Moreover one can easily show that the function  $H_1(\alpha_1(\beta), \beta)$  defined on the set  $\mathcal{C}_1$  is also convex and it also has continuous first derivatives inside of  $\mathcal{C}_1$ .

So to prove the lemma it is sufficient to show that for any  $\beta$  for which

$$H_0(\alpha_0(\beta), \beta) = H_1(\alpha_0(\beta), \beta)$$

the following equalities hold

$$H_1(\alpha_0(\beta), \beta) = \lim_{\beta' \rightarrow \beta, \beta' \in \mathcal{C}_1} H_1(\alpha_1(\beta'), \beta')$$

$$\partial_\beta H_1(\alpha_0(\beta), \beta) = \lim_{\beta' \rightarrow \beta, \beta' \in \mathcal{C}_1} \partial_{\beta'} H_1(\alpha_1(\beta'), \beta') = \partial_\beta H_1(\alpha_1(\beta), \beta)$$



The first one is obvious. The second one can easily be shown by a simple calculation.

■

Consider the Legendre transforms of the functions  $H_1(\cdot, \cdot)$  and  $\mathcal{H}(\cdot)$

$$L_1(v^0, \bar{v}) = \sup_{\alpha \in R, \beta \in R^\mu} \{\alpha v^0 + \beta \bar{v} - H_1(\alpha, \beta)\}$$

$$L_0(\bar{v}) = \sup_{\beta \in R^\mu} \{\beta \bar{v} - \mathcal{H}(\beta)\}$$

Let

$$L((x^0, \bar{x}), (v^0, \bar{v})) = \begin{cases} L_1(v^0, \bar{v}) & \text{if } x^0 = 0 \\ L_0(\bar{v}) & \text{otherwise} \end{cases}$$

For each continuous path  $\varphi : [0, \tau] \rightarrow R_+^1 \times R^\mu$  we define

$$\mathcal{L}_\tau(\varphi) = \begin{cases} \int_0^\tau L(\dot{\varphi}(t), \varphi(t)) dt, & \text{if } \varphi \text{ is absolutely continuous,} \\ +\infty & \text{otherwise.} \end{cases}$$

**Theorem 3.3.1** *The random walk  $S_t$  satisfies the large deviation principle with the action functionals  $\mathcal{L}_\tau$ .*

**Proof.** Due to the theorem 3.1.1 we should show that for any  $\tau > 0$  the following conclusions hold.

1. The functional  $\mathcal{L}_\tau$  is lower semicontinuous.
2. For any  $x \in R_+^1 \times R^\mu$ ,  $\varphi \in \Phi_{x, \tau}$  and for any  $\epsilon > 0$  there exists a piecewise linear path  $\tilde{\varphi} \in \Phi_{x, \tau}$  such that

o

$$\sup_{0 \leq t \leq \tau} |\varphi(t) - \tilde{\varphi}(t)| < \epsilon \text{ and } |\mathcal{L}_\tau(\varphi) - \mathcal{L}_\tau(\tilde{\varphi})| < \epsilon$$

3. The lower large deviation bound ( 16) and the upper large deviation bound ( 17) hold for any linear path  $\varphi$ .

The proof of the two first conclusions is quite standard. Let us prove the lower large deviation bound ( 16) and upper large deviation bound ( 17).

**Lemma 3.3.2** *Let  $\varphi : [0, \tau] \rightarrow R_+^1 \times R^\mu$ ,  $\varphi(t) = (\varphi^0(t), \bar{\varphi}(t))$  be a linear path such that for any  $0 < t < \tau$   $\varphi^0(t) \neq 0$  and  $\dot{\varphi}(t) = v$*

*Then the lower large deviation bound ( 16) and the upper large deviation bound ( 17) hold with*

$$\mathcal{L}_\tau(\varphi) = \tau L_1(v)$$

This lemma easily follows from the large deviation principle for homogeneous random walks in  $Z^{\mu+1}$  (see [9])

**Lemma 3.3.3** *Let  $\varphi : [0, \tau] \rightarrow R_+^1 \times R^\mu$ ,  $\varphi(t) = (\varphi^0(t), \bar{\varphi}(t))$  be a linear path such that for any  $t \in [0, \tau]$   $\varphi^0(t) = 0$  and  $\dot{\bar{\varphi}}(t) = \bar{v}$ .*

*Then the lower large deviation bound ( 16) and the upper large deviation bound ( 17) hold with*

$$\mathcal{L}_\tau(\varphi) = \tau L_0(\bar{v})$$

where  $\bar{v} = \dot{\bar{\varphi}}(t)$

**Proof.** Let  $\bar{v} = \dot{\bar{\varphi}}(t)$ ,  $\varphi(0) = 0$ ,  $x \in R_+^1 \times R^\mu$ ,  $|x| < \frac{\delta}{2}$ . Consider the random walk  $S_t = (S_t^0, \bar{S}_t)$  starting at the point  $[x, N]$ . Denote

$$A_{N\delta}^0 = \left\{ \sup_{t=0, \dots, N\tau} |S_t^0| < N\delta \right\}.$$

$$A_{N\delta}^1 = \left\{ \sup_{t=0, \dots, N\tau} |\bar{S}_t - \bar{v}t| < N\delta \right\}.$$

and

$$A_{N\delta} = \left\{ \sup_{t=0, \dots, N\tau} \left| S_t - \varphi\left(\frac{t}{N}\right) \right| < N\delta \right\} = A_{N\delta}^0 \cap A_{N\delta}^1$$

Consider a family of random walks in  $Z_+^1 \times Z^\mu$  with transition probabilities

$$\begin{aligned} p^{\alpha, \beta}((i, x), (j, y)) &= p_{i,j}^{\alpha, \beta}(x, y) = \\ p_{i,j}(x, y) \exp\{\alpha(j - i) + \beta(y - x) - H_i(\alpha, \beta)\} &= \\ = \frac{p_{i,j}(x, y) \exp\{\alpha(j - i) + \beta(y - x)\}}{\sum_y p_{i,j}(x, y) \exp\{\alpha(j - i) + \beta(y - \bar{x})\}}. \end{aligned}$$

Then

$$p_{i,j}^{0,0}(x,y) = p_{i,j}(x,y), \quad i,j \in Z_+^1, \quad x,y \in Z^\mu$$

We shall denote the corresponding distributions and expectations by  $P_{\alpha,\beta}, E_{\alpha,\beta}$ . One can easily show that for any  $\alpha \in R^1, \beta \in R^\mu$

$$\begin{aligned} P\{A_{N\delta}\} &= P_{0,0}\{A_{N\delta}\} = \\ &= E_{\alpha,\beta}(I_{A_{N\delta}} \exp\{-\alpha S_{[N\tau]}^0 - \beta \bar{S}_{[N\tau]} + \sum_{t=0}^{[N\tau]-1} H_{S_t^0}(\alpha, \beta)\}) \end{aligned} \quad (30)$$

where  $I_{A_{N\delta}}$  is an indicator of  $A_{N\delta}$ .

Let us consider  $\beta_{\bar{v}} = (\beta_{\bar{v}}^1, \dots, \beta_{\bar{v}}^\mu)$ ,  $\beta_{\bar{v}}^j \in R^1 \cup \{\pm\infty\}$   $j = 1, \dots, \mu$  such that

$$\begin{aligned} L_0(\bar{v}) &= \inf_{\beta} \{\bar{v}\beta - H_1(\alpha(\beta), \beta)\} = \\ &= \bar{v}\beta_{\bar{v}} - H_1(\alpha(\beta_{\bar{v}}), \beta_{\bar{v}}) \end{aligned} \quad (31)$$

Let us first prove the lower large deviation bound and upper large deviation bound for the case when

$$|\beta_{\bar{v}}^j| < \infty \text{ for any } j = 1, \dots, \mu \quad (32)$$

Then from the definition of the function  $\alpha(\beta)$  it follows that

$$|\alpha(\beta_{\bar{v}})| < \infty$$

From (30) for  $\beta = \beta_{\bar{v}}, \alpha = \alpha(\beta_{\bar{v}})$  we get

$$P(A_{N\delta}) \leq \exp\{-[N\tau]L_0(\bar{v}) + |\beta_{\bar{v}}| N\delta + |\alpha(\beta_{\bar{v}})| N\delta\} \quad (33)$$

So for the case when (32) holds the upper large deviation bound is proved.

Let us prove now the lower large deviation bound for the case when (32) holds. We consider here two cases:

Case 1.

$$H_0(\alpha(\beta_{\bar{v}}), \beta_{\bar{v}}) \leq H_1(\alpha(\beta_{\bar{v}}), \beta_{\bar{v}}) \quad (34)$$

Case 2.

$$H_0(\alpha(\beta_{\bar{v}}), \beta_{\bar{v}}) > H_1(\alpha(\beta_{\bar{v}}), \beta_{\bar{v}}) \quad (35)$$

Let ( 34) be satisfied. Then by definition

$$\alpha(\beta_{\bar{v}}) = \alpha_0(\beta_{\bar{v}})$$

and consequently for  $\alpha_{\bar{v}} = \alpha(\beta_{\bar{v}})$

$$\begin{aligned} \partial_{\alpha} H_1(\alpha_{\bar{v}}, \beta_{\bar{v}}) &= 0 \\ \partial_{\beta} H_1(\alpha_{\bar{v}}, \beta_{\bar{v}}) &= \bar{v} \end{aligned} \tag{36}$$

From ( 36) it follows that

$$\begin{aligned} E_{\alpha(\beta_{\bar{v}}), \beta_{\bar{v}}} (S_{t+1}^0 - S_t^0 \mid S_t^0 = i, \bar{S}_t) &= 0 \\ E_{\alpha(\beta_{\bar{v}}), \beta_{\bar{v}}} (\bar{S}_{t+1} - \bar{S}_t \mid S_t^0 = i, \bar{S}_t) &= \bar{v} \end{aligned} \tag{37}$$

for any  $i \in Z_+^1$ .  $i > 0$ . Consider  $i_0 \in Z_+^1$ ,  $i_0 > 0$  and  $y \in Z^m$  such that

$$p_{\Lambda}(i_0, y) > 0$$

Let

$$p_{\Lambda}(i_0, y) = q$$

Then for  $N_1 = \lfloor \sqrt{N} \rfloor$

$$\begin{aligned} P(A_{N\delta}) &= E_{\alpha_0(\beta_{\bar{v}}), \beta_{\bar{v}}} (I_{A_{N\delta}} \exp\{-\alpha_0(\beta_{\bar{v}})S_{[N\tau]}^0 - \beta_{\bar{v}}\bar{S}_{[N\tau]} + \\ &\quad + \sum_{t=0}^{[N\tau]-1} H_{S_t^0}(\alpha_0(\beta_{\bar{v}}), \beta_{\bar{v}})\}) \geq \\ &\geq q^{N_1} \exp\{-[N\tau]L_0(\bar{v}) - |\beta_{\bar{v}}| N\delta - |\alpha(\beta_{\bar{v}})| N\delta\} \times \\ &\times P_{\alpha_0(\beta_{\bar{v}}), \beta_{\bar{v}}} \{B_{N_1, N\delta} \mid S_{N_1}^0 = \epsilon_0 N_1, \bar{S}_{N_1} = N_1 y\} \end{aligned} \tag{38}$$

where

$$\begin{aligned} B_{N_1, N\delta} &= \left\{ \inf_{t=N_1, \dots, N\tau} |S_t^0| > 0, \sup_{t=N_1, \dots, N\tau} |S_t^0| < N\delta, \right. \\ &\quad \left. \sup_{t=N_1, \dots, N\tau} |\bar{S}_t - \bar{v}t| < \delta N \right\} \end{aligned}$$

From ( 37) it easily follows that there exists  $c > 0$  such that

$$P_{\alpha_0(\beta_{\bar{v}}), \beta_{\bar{v}}} \{B_{N_1, N\delta} \mid S_{N_1}^0 = \epsilon_0 N_1, \bar{S}_{N_1} = N_1 y\} \geq c \tag{39}$$

From ( 38) and ( 39) we get for the case 1 the lower large deviation bound.

Let us consider now the case 2. For this case by definition

$$\alpha(\beta_{\bar{\tau}}) = \alpha_1(\beta_{\bar{\tau}})$$

where  $\alpha(\beta_{\bar{\tau}})$  is defined by the system

$$\begin{cases} H_0(\alpha_1(\beta_{\bar{\tau}}), \beta_{\bar{\tau}}) = H_1(\alpha_1(\beta_{\bar{\tau}}), \beta_{\bar{\tau}}) \\ \partial_\alpha H_1(\alpha_1(\beta_{\bar{\tau}}), \beta_{\bar{\tau}}) < 0. \end{cases}$$

Therefore from ( 30) for  $\alpha = \alpha_1(\beta_{\bar{\tau}})$ ,  $\beta = \beta_{\bar{\tau}}$  one can easily get

$$\begin{aligned} P(A_{N\delta}) &= E_{\alpha_1(\beta_{\bar{\tau}}), \beta_{\bar{\tau}}}(I_{A_{N\delta}} \exp\{-\alpha_1(\beta_{\bar{\tau}})S_{[N\tau]}^0 - \beta_{\bar{\tau}}\bar{S}_{[N\tau]} + [N\tau]H_1(\alpha_1(\beta_{\bar{\tau}}), \beta_{\bar{\tau}})\}) \geq \\ &\geq \exp\{-N\tau L_0(\bar{\tau}) - N\delta(|\alpha_1(\beta_{\bar{\tau}})| + |\beta_{\bar{\tau}}|)\} \times \\ &\quad \times P_{\alpha_1(\beta_{\bar{\tau}}), \beta_{\bar{\tau}}}(A_{N\delta}) \end{aligned}$$

Let us prove now the following lemma.

**Lemma 3.3.4** *Let ( 35) holds then*

$$P_{\alpha_1(\beta_{\bar{\tau}}), \beta_{\bar{\tau}}}(A_{N\delta}) \rightarrow 1 \text{ as } N \rightarrow \infty$$

**Proof** Consider for any  $\alpha, \beta$  the induced Markov chain with the set of states  $Z_+$  and transition probabilities

$$p_{i,j}^{\alpha,\beta} = \sum_y p_{i,j}^{\alpha,\beta}(y).$$

Let ( 35) be satisfied. Then for  $\alpha = \alpha_1(\beta_{\bar{\tau}}), \beta = \beta_{\bar{\tau}}$  the induced Markov chain is ergodic. Consider for any  $\alpha, \beta$  for which the induced Markov chain is ergodic the stationary probabilities of this chain

$$\pi_j^{\alpha,\beta}, j \in Z_+$$

and consider the vector

$$V_0(\alpha, \beta) = \pi_0^{\alpha,\beta} \sum_{y,j} y p_{0,j}^{\alpha,\beta}(y) + (1 - \pi_0^{\alpha,\beta}) \sum_{y,j} y p_{1,j}^{\alpha,\beta}(y)$$

From the theorem 4.1.1 it easily follows that to prove the lemma 3.3.4 it is sufficient to show that

$$\bar{v} = V_0(\alpha_1(\beta_{\bar{v}}), \beta_{\bar{v}})$$

Let us calculate  $V_0(\alpha, \beta)$ . For this let us first note that for any  $\alpha, \beta$

$$\sum_{j,y} y p_{i,j}^{\alpha,\beta}(y) = \partial_\alpha H_i(\alpha, \beta) \quad (40)$$

Moreover using the method of generating functions one can easily show that for each  $\alpha, \beta$  for which the induced Markov chain is ergodic

$$\pi_0^{\alpha,\beta} = \frac{\partial_\alpha H_1(\alpha, \beta)}{\partial_\alpha H_0(\alpha, \beta) - \partial_\alpha H_1(\alpha, \beta)} \quad (41)$$

From (40) and (41) we get

$$V_0(\alpha, \beta) = \frac{\partial_\alpha(H_0(\alpha, \beta) - H_1(\alpha, \beta))}{\partial_\alpha H_1(\alpha, \beta) \partial_\beta H_0(\alpha, \beta) - \partial_\alpha H_0(\alpha, \beta) \partial_\beta H_1(\alpha, \beta)} \quad (42)$$

By a simple calculation one can easily show that for those  $\beta$  for which

$$\mathcal{H}_0(\beta) = H_0(\alpha_1(\beta), \beta) = H_0(\alpha_1(\beta), \beta)$$

the following equality holds

$$\frac{d}{d\beta} \mathcal{H}_0(\beta) = \frac{\partial_\alpha(H_0(\alpha, \beta) - H_1(\alpha, \beta))}{\partial_\alpha H_1(\alpha, \beta) \partial_\beta H_0(\alpha, \beta) - \partial_\alpha H_0(\alpha, \beta) \partial_\beta H_1(\alpha, \beta)} \quad (43)$$

But for  $\beta = \beta_{\bar{v}}$  from the definition of  $\beta_{\bar{v}}$  it follows that

$$\frac{d}{d\beta} \mathcal{H}_0(\beta_{\bar{v}}) = \bar{v}.$$

Consequently from (42) and (43) we get

$$V_0(\alpha_1(\beta_{\bar{v}}), \beta_{\bar{v}}) = \bar{v}.$$

Lemma 3.3.4 is proved.  $\blacklozenge$

We have proved the lower large deviation bound and upper large deviation bound for the case when for any  $j = 1, \dots, \mu$

$$|\beta_{\bar{v}}^j| < \infty$$

To consider the case when for some  $1 \leq j \leq \mu$

$$|\beta_v^j| = \infty$$

let us note that for any  $j = 1, \dots, \mu$ , for which  $\beta_v^j = \infty$ , if the trajectory belongs to the event  $A_{N\delta}$  then

$$S_t^j = tv^j \text{ for any } t = 0, \dots, [N\tau]$$

Considering now conditional distributions under the condition

$$S_t^j = tv^j \text{ for any } t = 0, \dots, [N\tau] \text{ for any } j \text{ for which } |\beta_v^j| = \infty.$$

and using for these conditional distributions the same arguments as in previous case one can easily get the lower and upper large deviation bounds.

The lemma 3.3.3 is proved.

■

### 3.4 Random walk in $Z_+^{\mu+1}$ with a discontinuity on a hyperplane

Let us consider the Markov chain with the set of states  $Z^{\mu+1}$  ( denote its state at time  $t$  by  $S_t(i, x)$  if the Markov chain starts from the point  $(i, x)$ ) and having the following transition probabilities

$$p((i, x) \rightarrow (j, y)) = p((i, x), (j, y)), i, j \in Z^1, x, y \in Z^\mu.$$

We shall assume that

(i) (boundedness of jumps)

$$p_{i,j}(x, y) = 0. \text{ if either } \max\{|i - j|, |x - y|\} > d. \text{ or } (j - i)\text{sign}(i) < -1$$

for some  $d > 0$  ;

(ii) (homogeneity) for all  $(i, x), (j, y), (k, z)$  such that  $\text{sign}(i) = \text{sign}(j)$  we have

$$p((i, x), (j, y)) = p((i + k, x + z), (j + k, y + z))$$

Put

$$p((i, x), (j, y)) = p_{ij}(y - x)$$

(iii) the induced Markov chain having the set of states  $Z^1$  and transition probabilities

$$p_{i,j} = \sum_y p_{i,j}(y)$$

is irreducible and aperiodic.

Define the following functions

$$H_+(\alpha, \beta) = \log\left(\sum_{j,y} p_{i,j}(y) \exp\{\alpha(j-i) + \beta y\}\right)$$

where  $i > 0$ ,  $\alpha \in R^1$ ,  $\beta = (\beta^1, \dots, \beta^\mu) \in R^\mu$ , and for  $y = (y^1, \dots, y^\mu)$  we put

$$\beta y = \sum_{k=1}^{\mu} \beta^k y^k,$$

$$H_-(\gamma, \beta) = \log\left(\sum_{j,y} p_{i,j}(y) \exp\{-\gamma(j-i) + \beta y\}\right)$$

where  $i < 0$ ,  $\gamma \in R$ , and

$$H_0(\alpha, \beta, \gamma) = \log\left(\sum_{y,j \geq 0} p_{0,j}(y) \exp\{\alpha j + \beta y\} + \sum_{y,j < 0} p_{0,j}(y) \exp\{-\gamma j + \beta y\}\right)$$

Assume that the jacobians of  $H_+$ ,  $H_0$  and  $H_-$  are nowhere zero.

Let us consider the following equations

$$\partial_\alpha H_+(\alpha, \beta) = 0 \tag{44}$$

$$\partial_\gamma H_-(\gamma, \beta) = 0 \tag{45}$$

It is easy to see that for each  $\beta \in R^\mu$  there exists a unique solution  $(\alpha_0(\beta), \beta)$  of the equation (44) and a unique solution  $(\gamma_0(\beta), \beta)$  of the equation (45).

**Lemma 3.4.1** *Let*

$$\max\{H_+(\alpha_0(\beta), \beta), H_-(\alpha_0(\beta), \beta)\} < H_0(\alpha_0(\beta), \beta, \gamma_0(\beta))$$

*Then one of the following conclusions holds*



1. either

$$H_+(\alpha_0(\beta), \beta) < H_-(\gamma_0(\beta), \beta) < H_0(\alpha_0(\beta), \beta, \gamma_0(\beta))$$

and there exists  $\alpha_1(\beta)$  such that

$$H_+(\alpha_1(\beta), \beta) < H_-(\gamma_0(\beta), \beta) = H_0(\alpha_1(\beta), \beta, \gamma_0(\beta))$$

and

$$\partial_\alpha H_+(\alpha_1(\beta), \beta) < 0$$

2. or

$$H_-(\gamma_0(\beta), \beta) < H_+(\alpha_0(\beta), \beta) < H_0(\alpha_0(\beta), \beta, \gamma_0(\beta))$$

and there exists  $\gamma_1(\beta)$  such that

$$H_-(\gamma_1(\beta), \beta) < H_+(\alpha_0(\beta), \beta) = H_0(\alpha_0(\beta), \beta, \gamma_1(\beta))$$

and

$$\partial_\gamma H_-(\gamma_1(\beta), \beta) < 0$$

3. or there exist  $\alpha_2(\beta)$  and  $\gamma_2(\beta)$  such that

$$H_+(\alpha_2(\beta), \beta) = H_-(\gamma_2(\beta), \beta) = H_0(\alpha_2(\beta), \beta, \gamma_2(\beta))$$

and

$$\partial_\alpha H_+(\alpha_2(\beta), \beta) < 0$$

$$\partial_\gamma H_-(\gamma_2(\beta), \beta) < 0$$

### **Proof of the lemma 3.4.1**

Let us consider the case when

$$H_+(\alpha_0(\beta), \beta) \leq H_-(\gamma_0(\beta), \beta) < H_0(\alpha_0(\beta), \beta, \gamma_0(\beta))$$

The case when

$$H_-(\gamma_0(\beta), \beta) < H_+(\alpha_0(\beta), \beta) < H_0(\alpha_0(\beta), \beta, \gamma_0(\beta))$$

can be considered similarly.

Note that  $H_0(\alpha, \beta, \gamma)$  is monotone increasing in  $\alpha$  for all  $\beta, \gamma$ , and the function  $H_+(\alpha, \beta)$  is convex in  $\alpha$  for all  $\beta$ . From this it follows that either there exists  $\alpha_1(\beta) < \alpha_0(\beta)$  such that

$$H_+(\alpha_1(\beta), \beta) < H_-(\gamma_0(\beta), \beta) = H_0(\alpha_1(\beta), \beta, \gamma_0(\beta))$$

and

$$\partial_\alpha H_+(\alpha_1(\beta), \beta) < 0$$

or there exists  $\hat{\alpha}(\beta) < \alpha_0(\beta)$  such that

$$H_+(\hat{\alpha}(\beta), \beta) = H_-(\gamma_0(\beta), \beta) \leq H_0(\hat{\alpha}(\beta), \beta, \gamma_0(\beta)) \quad (46)$$

Let us show that from (46) it follows that there exist  $\alpha_2(\beta)$  and  $\gamma_2(\beta)$  such that

$$H_+(\alpha_2(\beta), \beta) = H_-(\gamma_2(\beta), \beta) = H_0(\alpha_2(\beta), \beta, \gamma_2(\beta)) \quad (47)$$

and

$$\partial_\alpha H_+(\alpha_2(\beta), \beta) < 0$$

$$\partial_\gamma H_-(\gamma_2(\beta), \beta) < 0$$

For this let us consider the equation

$$H_+(\alpha, \beta) = H_-(\gamma, \beta) \quad (48)$$

If (46) holds then one can easily show that for each  $\gamma < \gamma_0(\beta)$  there exists the unique  $\alpha(\beta, \gamma) < \hat{\alpha}(\beta)$  such that  $(\alpha(\beta, \gamma), \beta, \gamma)$  is a solution of (48), and moreover  $\alpha(\beta, \gamma)$  is monotone increasing in  $\gamma$ , and

$$\alpha(\beta, \gamma) \rightarrow -\infty \text{ as } \gamma \rightarrow -\infty$$

Note that

$$H_-(\gamma, \beta) = H_+(\alpha(\beta, \gamma), \beta) \rightarrow +\infty$$

as  $\gamma \rightarrow -\infty$  and the function  $H_0(\alpha(\beta, \gamma), \beta, \gamma)$  is monotone decreasing as  $\gamma \rightarrow -\infty$ . Then there exists the unique  $\gamma_2(\beta) < \gamma_0(\beta)$  such that

$$H_+(\alpha(\beta, \gamma_2(\beta)), \beta) = H_-(\gamma_2(\beta), \beta) = H_0(\alpha(\beta, \gamma_2(\beta)), \beta, \gamma_2(\beta))$$

Since  $\gamma_2(\beta) < \gamma_0(\beta)$  and  $\alpha(\beta, \gamma_2(\beta)) \leq \delta(\beta) < \alpha_0(\beta)$  then

$$\partial_\alpha H_+(\alpha(\beta, \gamma_2(\beta)), \beta) < 0$$

$$\partial_\alpha H_-(\gamma_2(\beta), \beta) < 0$$

So, putting  $\alpha_2(\beta) = \alpha(\beta, \gamma_2(\beta))$  we get ( 47).

Lemma 3.4.1 is proved.

■

Let us define the function  $\mathcal{H}(\beta)$  by putting

$$\mathcal{H}(\beta) = \max\{H_+(\alpha_0(\beta), \beta), H_-(\alpha_0(\beta), \beta)\}$$

if

$$\max\{H_+(\alpha_0(\beta), \beta), H_-(\alpha_0(\beta), \beta)\} \geq H_0(\alpha_0(\beta), \beta, \gamma_0(\beta))$$

Otherwise we put

$$\mathcal{H}(\beta) = H_-(\gamma_0(\beta), \beta)$$

if the case 1 of the lemma 3.4.1 holds, or

$$\mathcal{H}(\beta) = H_+(\alpha_0(\beta), \beta)$$

if the case 2 of the lemma 3.4.1 holds, or

$$\mathcal{H}(\beta) = H_-(\gamma_2(\beta), \beta) = H_+(\alpha_2(\beta), \beta)$$

if the case 3 of the lemma 3.4.1 holds. Then the function  $\mathcal{H}$  is defined for all  $\beta$ .

**Lemma 3.4.2** *The function  $\mathcal{H}$  is convex and belongs to  $C^1(R^\mu)$ .*

**Proof of the lemma 3.4.2.**

Introduce the following sets

$$\mathcal{C}_+ = \{\beta \in R^\mu : \mathcal{H}(\beta) = H_+(\alpha_0(\beta), \beta)\},$$

$$\mathcal{C}_- = \{\beta \in R^\mu : \mathcal{H}(\beta) = H_-(\gamma_0(\beta), \beta)\},$$

$$\mathcal{C}_0 = \{\beta \in R^\mu : \mathcal{H}(\beta) = H_+(\alpha_2(\beta), \beta) = H_-(\gamma_2(\beta), \beta)\}.$$

Inside of each of these sets  $\mathcal{H}$  is convex and smooth.

Let  $\mathcal{C}_+ \cap \mathcal{C}_0 \neq \emptyset$ . Consider  $\beta^* \in \mathcal{C}_+ \cap \mathcal{C}_0$ . It can be verified by the direct calculation that the function  $\mathcal{H}$  is continuous in  $\beta^*$  and

$$\lim_{\beta \rightarrow \beta^*, \beta \in \mathcal{C}_+} \nabla \mathcal{H}(\beta) = \lim_{\beta \rightarrow \beta^*, \beta \in \mathcal{C}_0} \nabla \mathcal{H}(\beta)$$

Then the function  $\mathcal{H}$  is convex on the set  $\mathcal{C}_+ \cap \mathcal{C}_0$  and it has continuous first derivatives inside this set.

Similarly, one can show that  $\mathcal{H}$  is convex on the set  $\mathcal{C}_- \cap \mathcal{C}_0$  and also has continuous first derivatives inside this set.

Note also that  $\mathcal{C}_+ \cap \mathcal{C}_- = \emptyset$ . Then  $\mathcal{H}$  is convex on the set

$$\mathcal{C}_+ \cap \mathcal{C}_0 \cup \mathcal{C}_- \cap \mathcal{C}_0 = R^\mu$$

and it is of the class  $C^1(R^\mu)$ .

Lemma 3.4.2 is proved.

■

Let  $L_+$ ,  $L_-$  and  $L_0$  be the Legendre transforms of the functions  $H_+$ ,  $H_-$  and  $\mathcal{H}$  correspondingly.

$$L_+(u, v) = \sup_{\alpha, \beta} \{\alpha u + \beta v - H_+(\alpha, \beta)\}$$

$$L_-(u, v) = \sup_{\gamma, \beta} \{\gamma u + \beta v - H_-(\gamma, \beta)\}$$

$$L_0(v) = \sup_{\beta} \{\beta v - \mathcal{H}(\alpha, \beta)\}$$

Consider the following function  $L : R^{\mu+1} \times R^{\mu+1} \rightarrow R$

$$L((u, v), (x_0, x)) = \begin{cases} L_+(u, v) & \text{if } x^0 > 0 \\ L_-(u, v) & \text{if } x^0 < 0 \\ L_0(v) & \text{if } x^0 = 0 \end{cases}$$

For each  $\tau \geq 0$  let us define on the set of all continuous paths

$$\varphi : [0, \tau] \rightarrow R^{\mu+1}$$

the functional  $\mathcal{L}_\tau$

$$\mathcal{L}_\tau(\varphi) = \int_0^\tau L(\dot{\varphi}(t), \varphi(t)) dt$$

if the path  $\varphi$  is absolutely continuous, and

$$\mathcal{L}_\tau(\varphi) = \infty$$

otherwise.

**Theorem 3.4.1** *For the random walk  $S_t$  the large deviation principle holds with the action functionals  $\mathcal{L}_\tau$ .*

### 3.5 Optimal paths.

Consider a random walk  $S_t, t \in Z_+$  in  $Z_+^\nu \times Z^\mu$  defined in section 3.1. Assume that this random walk satisfies the large deviation principle with the action functionals  $\mathcal{L}_\tau$ .

For any  $x, y \in R_+^\nu \times R^\mu$  let us consider the set of all continuous paths going from  $x$  to  $y$ . We shall denote it by  $\Phi^{x,y}$ .

**Definition 3.5.1** *Consider two points  $x, y \in R_+^\nu \times R^\mu$ .*

*A path  $\varphi : [0, \tau] \rightarrow R_+^\nu \times R^\mu$ ,  $\varphi \in \Phi^{x,y}$ , is called to be an optimal path from the point  $x$  to the point  $y$  if for any  $\tau'$  and for any path  $\varphi' : [0, \tau'] \rightarrow R_+^\nu \times R^\mu$ ,  $\varphi' \in \Phi^{x,y}$ , the following inequality holds*

$$\mathcal{L}_\tau(\varphi) \leq \mathcal{L}_{\tau'}(\varphi')$$

Define

$$\mathcal{L}_{x,y} = \inf_{\tau} \inf_{\varphi : [0, \tau] \rightarrow R_+^\nu \times R^\mu, \varphi \in \Phi^{x,y}} \mathcal{L}_\tau(\varphi).$$

If there exists an optimal path  $\varphi : [0, \tau] \rightarrow R_+^\nu \times R^\mu$  from the point  $x$  to the point  $y$  then

$$\mathcal{L}_{x,y} = \mathcal{L}_\tau(\varphi)$$

Consider some properties of the optimal paths.

**Lemma 3.5.1** *(Additivity.) Let  $\varphi : [0, \tau] \rightarrow R_+^\nu \times R^\mu$  be an optimal path from the point  $x$  to the point  $y$ . Then for any  $t \in [0, \tau]$  the path  $\varphi : [0, t] \rightarrow R_+^\nu \times R^\mu$  is optimal from  $x$  to  $z = \varphi(t)$ , the path  $\varphi : [t, \tau] \rightarrow R_+^\nu \times R^\mu$  is optimal from  $z$  to  $y$ , and*

$$\mathcal{L}_{x,y} = \mathcal{L}_{x,z} + \mathcal{L}_{z,y}$$

This lemma easily follows from the integral representation of the action functional.

**Definition 3.5.2** *We shall say that an affine mapping*

$$G : R_+^\nu \times R^\mu \rightarrow R_+^\nu \times R^\mu$$

*is a proper mapping iff for any face  $\Lambda$*

$$G(\Lambda) = \Lambda$$

It is easy to see that for any proper mapping  $G$  there exist  $k \in R_+$  and  $b = (0, b^2) \in R_+^\nu \times R^\mu$  such that

$$G(x) = kx + b.$$

**Lemma 3.5.2** *(Invariance with respect to proper mappings.) Let  $\varphi : [0, \tau] \rightarrow R_+^\nu \times R^\mu$  be an optimal path from  $x$  to  $y$ .*

*Then for any proper mapping  $G(x) = kx + b$  the path  $\varphi' : [0, k\tau] \rightarrow R_+^\nu \times R^\mu$ , where  $\varphi'(t) = k\varphi(kt) + b$ ,  $t \in R_+$ , is an optimal path from the point  $G(x)$  to the point  $G(y)$*

This lemma easily follows from the definition of the random walk  $S_t$ . Let  $p((x, y) \rightarrow (x', y'))$ ,  $(x, y), (x', y') \in Z_+^\nu \times Z^\mu$  be the transition probabilities of the random walk  $S_t$ . Then, by definition, for any face  $\Lambda$  and for any  $(x, y) \in \Lambda \cap Z_+^\nu \times Z^\mu$

$$p((x, y) \rightarrow (x', y')) = p(\Lambda, (x' - x, y' - y)), \quad (x', y') \in Z_+^\nu \times Z^\mu.$$

For each face  $\Lambda$  consider the function

$$H_\Lambda^{\nu, \mu}(\alpha, \beta) = \sum_{x \in Z_+^\nu, y \in Z^\mu} p(\Lambda, (x, y)) \exp\{\alpha x + \beta y\}$$

For  $\nu = 0$  we should consider only the face  $\Lambda = \{\emptyset\}$  and then

$$H_{\{\emptyset\}}^{0, \mu}(\alpha, \beta) = H^\mu(\beta)$$

Consider the Legendre transform  $L^\mu(\cdot)$  of the function  $H^\mu(\cdot)$ .

For  $\nu = 0$  the random walk  $S_t$  in  $Z^\mu$  is homogeneous by definition and it satisfied the large deviation principle with the action functionals  $\mathcal{L}_\tau$  where

$$\mathcal{L}_\tau(\varphi) = \int_0^\tau L^\mu(\dot{\varphi}(t))dt$$

if the path  $\varphi : [0, \tau] \rightarrow R^\mu$  is absolutely continuous and

$$\mathcal{L}_\tau(\varphi) = \infty$$

otherwise (see [9] ).

**Theorem 3.5.1** *Let  $\nu = 0$ , and*

$$\nabla H^\mu(0) \neq 0.$$

*Then for any  $x \neq y \in R^\mu$  there exists the unique optimal path  $\varphi : [0, \tau] \rightarrow R^\mu$  from the point  $x$  to the point  $y$ . This optimal path is linear*

$$\varphi(t) = x + \frac{t}{\tau}(y - x),$$

and

$$\mathcal{L}_{x,y} = \mathcal{L}_\tau(\varphi) = (\beta, y - x)$$

where  $(\beta, \tau)$  is a unique solution of the system

$$\begin{cases} H^\mu(\beta) = 0, \\ \tau \nabla H^\mu(\beta) = y - x \\ \tau > 0. \end{cases} \quad (19)$$

**Proof.** From the lemma 3.5.1 and lemma 3.5.2 it easily follows that if the optimal path from the point  $x$  to the point  $y$  exists then it is linear. For any linear path

$$\varphi(t) = x + \frac{t}{\tau}(y - x)$$

one has

$$\mathcal{L}_\tau(\varphi) = \tau L^\mu\left(\frac{y-x}{\tau}\right)$$

Therefore for an optimal path  $\varphi : [0, \tau] \rightarrow R^\mu$

$$\tau L^\mu\left(\frac{y-x}{\tau}\right) = \inf_{t>0} \left\{ t L^\mu\left(\frac{y-x}{t}\right) \right\}$$

Let us note that the function  $tL^\mu\left(\frac{y-x}{t}\right)$  is convex with respect to  $t$  for any  $y \neq x$  and

$$tL^\mu\left(\frac{y-x}{t}\right) \rightarrow \infty \text{ as } t \rightarrow 0 \text{ or } t \rightarrow \infty.$$

From this it follows that  $\tau$  is a unique solution of the equation

$$\frac{d}{dt} \left( t L^\mu\left(\frac{y-x}{t}\right) \right) = 0 \quad (50)$$

It is easy to see that  $t = \tau$  is a solution of the equation (50) if  $(\tau, \beta)$ , where  $\beta = \nabla L^\mu\left(\frac{y-x}{\tau}\right)$ , is a solution of the system (49). Due to the convexity of the function  $H^\mu(\cdot)$  this system has a unique solution. From this it follows the theorem 3.5.1. ■

Let us consider now the case  $\nu = 1$ . Consider the following equation

$$\partial_\alpha H_{\{1\}}^{1,\mu}(\alpha, \beta) = 0 \quad (51)$$

For any  $\beta$  there exists a unique solution  $(\alpha_0(\beta), \beta)$  of the equation (51). Note that for any  $\beta$  for which

$$H_{\{1\}}^{1,\mu}(\alpha_0(\beta), \beta) < H_{\{\emptyset\}}^{1,\mu}(\alpha_0(\beta), \beta)$$

there exists a unique solution  $(\alpha_1(\beta), \beta)$  of the system

$$\begin{cases} H_{\{1\}}^{1,\mu}(\alpha, \beta) = H_{\{\emptyset\}}^{1,\mu}(\alpha, \beta) \\ \partial_\alpha H_{\{1\}}^{1,\mu}(\alpha, \beta) < 0 \end{cases} \quad (52)$$

Consider the function

$$\mathcal{H}_\emptyset^{1,\mu}(\beta) = \begin{cases} H_{\{1\}}^{1,\mu}(\alpha_0(\beta), \beta) & \text{if } H_{\{1\}}^{1,\mu}(\alpha_0(\beta), \beta) \geq H_{\{\emptyset\}}^{1,\mu}(\alpha_0(\beta), \beta) \\ H_{\{1\}}^{1,\mu}(\alpha_1(\beta), \beta) & \text{otherwise.} \end{cases}$$



**Theorem 3.5.2** *Let  $\nabla \mathcal{H}_\theta^{1,\mu}(0) \neq 0$ . Then for any  $x = (x^0, \bar{x}), y = (y^0, \bar{y}) \in R_+^1 \times R^\mu$  such that  $x^0 = y^0 = 0$  and  $\bar{x} \neq \bar{y}$  there exists the unique optimal path  $\varphi : [0, \tau] \rightarrow R_+^1 \times R^\mu$  from  $x$  to  $y$ , this optimal path is linear*

$$\varphi(t) = x + \frac{t}{\tau}(y - x)$$

and

$$\mathcal{L}_{x,y} = \mathcal{L}_\tau(\varphi) = (\beta, \bar{y} - \bar{x})$$

where  $(\beta, \tau)$  is a unique solution of the system

$$\begin{cases} \mathcal{H}_\theta^{1,\mu}(\beta) = 0, \\ \tau \nabla \mathcal{H}_\theta^{1,\mu}(\beta) = \bar{y} - \bar{x}. \end{cases} \quad (53)$$

To prove this theorem note first that for any linear path  $\varphi : [0, \tau] \rightarrow R_+^1 \times R^\mu$  such that  $\varphi(t) = (\varphi^0(t), \bar{\varphi}(t)), \varphi^0(t) = 0$ , we have

$$\mathcal{L}_\tau(\varphi) = \tau L_\theta \left( \frac{\varphi(\tau) - \varphi(0)}{\tau} \right),$$

where  $L_\theta(\cdot)$  is the Legendre transform of the function  $\mathcal{H}_\theta^{1,\mu}(\cdot)$ . Then it is sufficient to repeat the proof of the theorem 3.5.1.

For arbitrary  $x, y \in R_0^1 \times R^\mu$  one can easily get the following theorem.

**Theorem 3.5.3** *Let  $\nabla \mathcal{H}_\theta^{1,\mu}(0) \neq 0$ . Then for any  $x = (x^0, \bar{x}), y = (y^0, \bar{y})$  there exists an optimal path  $\varphi : [0, \tau] \rightarrow R_+^1 \times R^\mu$  from  $x$  to  $y$ , this optimal path is piecewiselincar*

$$\varphi(t) = \begin{cases} x + \frac{t}{\tau_1}(x_1 - x) & \text{for } 0 \leq t \leq \tau_1 \\ x_1 + \frac{t - \tau_1}{\tau_2}(x_2 - x_1) & \text{for } \tau_1 \leq t \leq \tau_1 + \tau_2 \\ x_2 + \frac{t - \tau_2 - \tau_1}{\tau_3}(y - x_2) & \text{for } \tau_1 + \tau_2 \leq t \leq \tau_1 + \tau_2 + \tau_3 \end{cases}$$

where  $x_1 = (0, \bar{x}_1), x_2 = (0, \bar{x}_2)$ , and

$$\mathcal{L}_{x,y} = \tau_1 L_{\{1\}}^{1,\mu} \left( \frac{x_1 - x}{\tau_1} \right) + \tau_2 L_\theta^{1,\mu} \left( \frac{\bar{x}_2 - \bar{x}_1}{\tau_2} \right) + \tau_3 L_{\{1\}}^{1,\mu} \left( \frac{y - x_2}{\tau_3} \right) =$$

$$= \inf_{t_1 \geq 0, t_2 \geq 0, \tau_3 \geq 0, \bar{x}_1, \bar{x}_2} t_1 L_{\{1\}}^{1,\mu}\left(\frac{x_1 - x}{t_1}\right) + t_2 L_{\emptyset}\left(\frac{\bar{x}_2 - \bar{x}_1}{t_2}\right) + t_3 L_{\{1\}}\left(\frac{y - x_2}{t_3}\right)$$

where  $L_{\{1\}}(\cdot)$  is the Legendre transform of the function  $H_{\{1\}}^{1,\mu}(\cdot)$ .  $L_{\emptyset}(\cdot)$  is the Legendre transform of the function  $\mathcal{H}_{\emptyset}^{1,\mu}(\cdot)$ .

Let us consider the case  $\nu = \mu = 1$ . We shall assume that

$$\frac{d}{d\beta} \mathcal{H}_{\emptyset}^{1,1}(0) \neq 0 \quad (54)$$

Then from the construction of the function  $\mathcal{H}_{\emptyset}^{1,1}(0)$  it follows that

$$\nabla H_{\{1\}}^{1,1}(0, 0) \neq 0.$$

Consider the following equation

$$\mathcal{H}_{\emptyset}^{1,1}(\beta) = 0.$$

Due to (54) this equation has exactly two different real solutions  $\beta_1 \leq 0 \leq \beta_2$ ,  $\beta_1 \neq \beta_2$ . Consider also the system

$$\begin{cases} H_{\{1\}}^{1,1}(\alpha, \beta) = 0 \\ \tau \nabla H_{\{1\}}^{1,1}(\alpha, \beta) = x \\ \tau > 0. \end{cases} \quad (55)$$

For any  $x = (x^0, x^1) \neq 0$  this system has the unique solution  $\alpha^*(x), \beta^*(x), \tau^*(x)$ .

**Theorem 3.5.4** *Let (54) be satisfied. Then for any  $x = (x^0, x^1) \in R_+^1 \times R^1$  the following conclusions hold :*

(i) *Let  $\beta_1 \leq \beta^*(x) \leq \beta_2$  then*

$$\mathcal{L}_{0,x} = \alpha^*(x)x^0 + \beta^*(x)x^1$$

*and the optimal path from 0 to  $x$  is linear*

$$\varphi(t) = \frac{t}{\tau^*(x)}x, \quad t \in [0, \tau^*(x)].$$

(ii) Let  $\beta^*(x) < \beta_1$ , then

$$\mathcal{L}_{0,x} = \alpha_1 x^0 + \beta_1 x^1$$

where  $\alpha_1$  is defined by the system

$$\begin{cases} H_{\{1\}}^{1,1}(\alpha_1, \beta_1) = 0, \\ \partial_\alpha H_{\{1\}}^{1,1}(\alpha_1, \beta_1) > 0 \end{cases} \quad (56)$$

and the optimal path from 0 to  $x$  is piecewise linear

$$\varphi(t) = \begin{cases} \frac{t}{\tau_-^0} z_- & \text{if } 0 \leq t \leq \tau_-^0, \\ z_- + \frac{t - \tau_-^0}{\tau_-^*} (x - z_-) & \text{if } \tau_-^0 \leq t \leq \tau_-^0 + \tau_-^* \end{cases}$$

where  $z_- = (0, z_-^1)$ ,  $z_-^1 < 0$ ,  $\tau_-^0 > 0$ ,  $\tau_-^* > 0$  are defined by the system

$$\begin{cases} \nabla H_{\{1\}}^{1,1}(\alpha_1, \beta_1) = \frac{x - z_-}{\tau_-^*}, \\ \partial_\beta \mathcal{H}_\emptyset^{1,1}(\beta_1) = \frac{z_-^1}{\tau_-^0}. \end{cases}$$

(iii) Let  $\beta_2 < \beta^*(x)$ , then

$$\mathcal{L}_{0,x} = \alpha_2 x^0 + \beta_2 x^1$$

where  $\alpha_2$  is defined by the system

$$\begin{cases} H_{\{1\}}^{1,1}(\alpha_2, \beta_2) = 0, \\ \partial_\alpha H_{\{1\}}^{1,1}(\alpha_2, \beta_2) > 0 \end{cases} \quad (57)$$

and the optimal path from 0 to  $x$  is piecewise linear

$$\varphi(t) = \begin{cases} \frac{t}{\tau_+^0} z_+ & \text{if } 0 \leq t \leq \tau_+^0, \\ z_+ + \frac{t - \tau_+^0}{\tau_+^*} (x - z_+) & \text{if } \tau_+^0 \leq t \leq \tau_+^0 + \tau_+^* \end{cases}$$

where  $z_+ = (0, z_+^1)$ ,  $z_+^1 > 0$ ,  $\tau_+^0 > 0$ ,  $\tau_+^* > 0$  are defined by the system

$$\begin{cases} \nabla H_{\{1\}}^{1,1}(\alpha_2, \beta_2) = \frac{x - z_+}{\tau_+^*}, \\ \frac{d}{d\beta} \mathcal{H}_0^{1,1}(\beta_2) = \frac{z_+^1}{\tau_+^0}. \end{cases}$$

Before starting the proof of the theorem 3.5.4 let us give a geometric interpretation to the conditions (i),(ii) and (iii) of this theorem. For this let us introduce the polar coordinates in  $R_+^1 \times R^1 \setminus \{0\}$ .

$$x^1 = r(x) \cos \gamma(x), \quad x^0 = r(x) \sin \gamma(x)$$

$$r(x) > 0, \quad 0 \leq \gamma(x) \leq \pi.$$

Let us consider two angles  $\gamma_2 < \gamma_1$  such that

$$\text{ctg} \gamma_1 = \frac{\partial_\beta H(\alpha_1, \beta_1)}{\partial_\alpha H(\alpha_1, \beta_1)}$$

and

$$\text{ctg} \gamma_2 = \frac{\partial_\beta H(\alpha_2, \beta_2)}{\partial_\alpha H(\alpha_2, \beta_2)}$$

$\gamma_1$  is the angle between the positive direction of the axis  $x^1$ , ( $x^0 = 0$ ) and the normal vector to the curve

$$H(\alpha, \beta) = 0$$

at the point  $(\alpha_1, \beta_1)$ .

$\gamma_2$  is the angle between the positive direction of the axis  $x^1$  and the normal vector to the curve

$$H(\alpha, \beta) = 0$$

at the point  $(\alpha_2, \beta_2)$ .

One can easily show that  $0 \leq \gamma_2 < \gamma_1 \leq \pi$ .

Let us note now that for any  $x \in R_+^1 \times R^1$

$$\beta^*(x) = \beta_1 \iff \gamma(x) = \gamma_1,$$

$$\beta^*(x) = \beta_2 \iff \gamma(x) = \gamma_2,$$

and moreover

$$\beta_1 \leq \beta^*(x) \leq \beta_2 \iff \gamma_2 \leq \gamma(x) \leq \gamma_1.$$

$$\beta^*(x) < \beta_1 \iff \gamma(x) > \gamma_1.$$

$$\beta^*(x) > \beta_2 \iff \gamma(x) < \gamma_2.$$

Due to the theorem 3.5.4 for any  $x \in R_+^1 \times R^1$  the following conclusions hold.

(i) Let  $\gamma_2 \leq \gamma(x) \leq \gamma_1$ . Then the optimal path from the point 0 to the point  $x$  is linear.

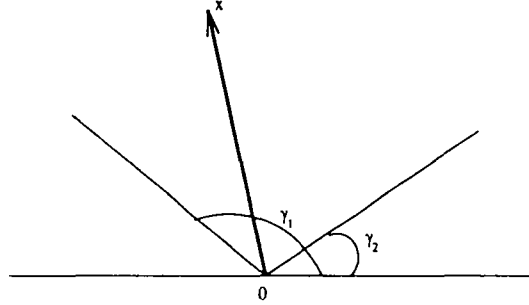

(ii) Let  $\gamma(x) > \gamma_1$ . Then the optimal path from the point 0 to the point  $x$  is the piecewiselinear path  $\varphi_1$  consisting of two linear segments: the optimal path from 0 to  $z_- = (0, z_-^1)$  and the optimal path from  $z_-$  to  $x$ , where  $z_- = (0, z_-^1)$ ,  $z_-^1 < 0$  is uniquely defined by the equality

$$\gamma(x - z_-) = \gamma_1$$

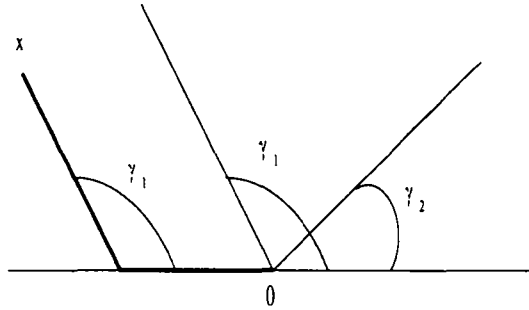

(iii) Let  $\gamma(x) < \gamma_1$ . Then the optimal path from the point 0 to the point  $x$  is the piecewiselinear path  $\varphi_1$  consisting of two linear segments: the optimal path from 0 to  $z_+ = (0, z_+^1)$  and the optimal path from  $z_+$  to  $x$ , where  $z_+ = (0, z_+^1)$ ,  $z_+^1 < 0$  is uniquely defined by the equality

$$\gamma(x - z_+) = \gamma_2$$

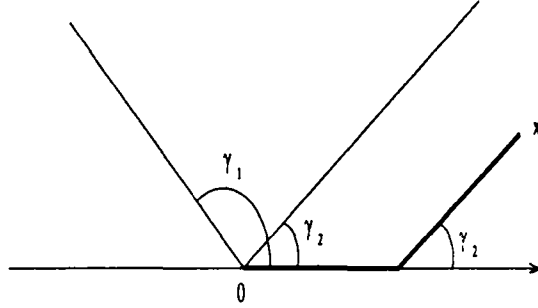

**Proof of theorem 3.5.4.** For any  $x = (x^0, x^1)$  for which  $x^0 = 0$  this theorem easily follows from the theorem 3.5.2.

Consider  $x = (x^0, x^1) \in R_+^1 \times R^1$ ,  $x^0 \neq 0$ . Due to the theorem 3.5.3 there exists a piecewiselinear optimal path from 0 to  $x$

$$\varphi(t) = \begin{cases} \frac{t}{\tau^\emptyset} z & \text{if } 0 \leq t \leq \tau^\emptyset. \\ z + \frac{t - \tau^\emptyset}{\tau^*} (x - z) & \text{if } \tau^\emptyset \leq t \leq \tau^\emptyset + \tau^* \end{cases}$$

and

$$\begin{aligned} \mathcal{L}_{0,x} &= \tau^\emptyset L_{\{\emptyset\}}^{1,1} \left( \frac{z^1}{\tau^\emptyset} \right) + \tau^* L_{\{1\}}^{1,1} \left( \frac{x^1 - z^1}{\tau^*} \right) = \\ &= \inf_{t_1 \geq 0, t_2 \geq 0, z = (0, z^1)} t_1 L_{\{\emptyset\}}^{1,1} \left( \frac{z^1}{t_1} \right) + t_2 L_{\{1\}}^{1,1} \left( \frac{x^1 - z^1}{t_2} \right) \end{aligned} \quad (58)$$

where  $z = (0, z^1)$ ,  $\tau^\emptyset \geq 0$ ,  $\tau^* \geq 0$  are defined by (58).

Consider for any  $z = (0, z^1) \neq 0$

$$F(z) = \inf_{t_1 > 0, t_2 > 0} \left\{ t_1 L_{\{\emptyset\}}^{1,1} \left( \frac{z^1}{t_1} \right) + t_2 L_{\{1\}}^{1,1} \left( \frac{x^1 - z^1}{t_2} \right) \right\}$$

and

$$F(0) = \inf_{t \geq 0} \left\{ t L_{\{1\}}^{1,1} \left( \frac{x^1}{t} \right) \right\}$$

Then

$$\mathcal{L}_{0,x} = \inf_{z = (0, z^1)} F(z) \quad (59)$$

One can easily show that

$$F(0) = \tau^*(x) L_{\{1\}}^{1,1} \left( \frac{x^1}{\tau^*(x)} \right) =$$

$$= \alpha^*(x)x^0 + \beta^*(x)x^1$$

and

$$\begin{aligned} F(z) &= \tau^\emptyset(z)L_\emptyset\left(\frac{z^1}{\tau^\emptyset(z)}\right) + \tau^*(x-z)L_{\{1\}}^{1,1}\left(\frac{x-z}{\tau^*(x-z)}\right) = \\ &= \beta^\emptyset(z)z^1 + \alpha^*(x-z)x^0 + \beta^*(x-z)(x^1 - z^1) \end{aligned}$$

where  $\alpha^*(x-z)$ ,  $\beta^*(x-z)$ ,  $\tau^*(x-z)$  is a unique solution of the system

$$\begin{cases} H_{\{1\}}^{1,1}(\alpha, \beta) = 0 \\ \nabla H_{\{1\}}^{1,1}(\alpha, \beta) = \frac{x-z}{\tau} \end{cases}$$

and  $\beta^\emptyset(z)$ ,  $\tau^\emptyset(z)$  is a unique solution of the system

$$\begin{cases} \mathcal{H}_{\{\emptyset\}}^{1,1}(\beta) = 0, \\ \frac{d}{d\beta} \mathcal{H}_{\{\emptyset\}}^{1,1}(\beta) = \frac{z^1}{\tau} \end{cases}$$

Note that

$$\beta^\emptyset(z) = \begin{cases} \beta_1 & \text{if } z^1 > 0 \\ \beta_2 & \text{if } z^1 < 0. \end{cases}$$

Therefore

$$F(z) = \begin{cases} \beta_1 z^1 + \alpha^*(x-z)x^0 + \beta^*(x-z)(x^1 - z^1) & \text{if } z^1 < 0 \\ \alpha^*(x)x^0 + \beta^*(x)x^1 & \text{if } z = 0 \\ \beta_2 z^1 + \alpha^*(x-z)x^0 + \beta^*(x-z)(x^1 - z^1) & \text{if } z^1 > 0 \end{cases}$$

Note also that

$$\beta^*(x-z) \rightarrow \bar{\beta} > 0 \text{ as } z = (0, z^1), z^1 \rightarrow -\infty$$

and

$$\beta^*(x-z) \rightarrow \underline{\beta} < 0 \text{ as } z = (0, z^1), z^1 \rightarrow +\infty$$

where  $(\underline{\alpha}, \underline{\beta}), (\bar{\alpha}, \bar{\beta})$  are the two different solutions of the system

$$\begin{cases} H_{\{1\}}^{1,1}(\alpha, \beta) = 0 \\ \partial_{\alpha} H_{\{1\}}^{1,1}(\alpha, \beta) = 0. \end{cases}$$

It is easy to see that the function  $F(\cdot)$  is continuous and it is convex on each of the sets  $\{z^1 \leq 0\}$  and  $\{z^1 \geq 0\}$ , but it should not be convex on  $R^1$ . Therefore

$$F(z) \rightarrow \infty \text{ as } z^1 \rightarrow \pm\infty$$

So to get the infimum ( 57) we must consider

$$F'_-(0) = \lim_{z \rightarrow 0^-} \frac{d}{dz^1} F(z) = \beta_1 - \beta^*(x),$$

and

$$F'_+(0) = \lim_{z \rightarrow 0^+} \frac{d}{dz^1} F(z) = \beta_2 - \beta^*(x).$$

Let us consider three cases.

(i) Let  $\beta_1 \leq \beta^*(x) \leq \beta_2$ . Then  $F'_-(0) \leq 0$  and  $F'_+(0) \geq 0$ .

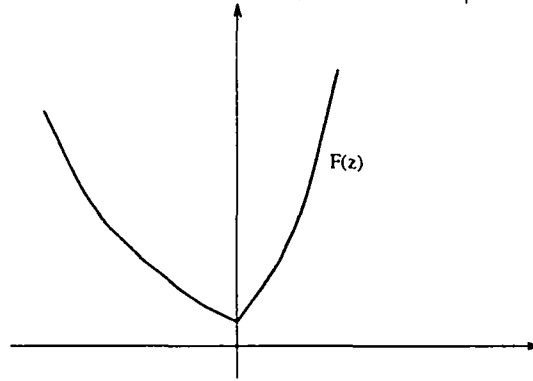

In this case the function  $F(\cdot)$  is convex on  $R^1$  and it has a unique infimum in the point  $z = 0$ .

(ii) Let  $\beta^*(x) < \beta_1$ . Then  $F'_-(0) > 0$ , and  $F'_+(0) \geq 0$ .



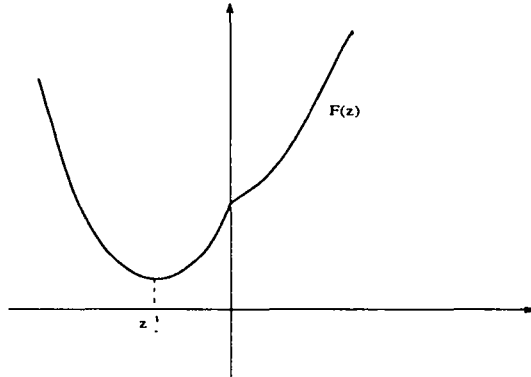

In this case the function  $F(\cdot)$  has a unique infimum in the point  $z_- = (0, z_-^1)$ ,  $z_-^1 < 0$  which is defined by the following equation

$$J^*(x - z) = \beta_1, \quad z = (0, z_-^1).$$

(iii) Let  $\beta_2 < J^*(x)$ . Then  $F'_-(0) \leq 0$ , and  $F'_+(0) < 0$ .

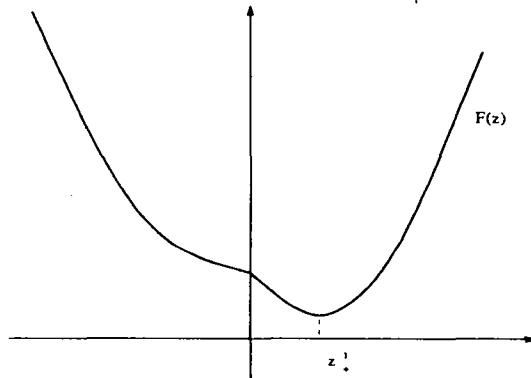

In this case the function  $F(\cdot)$  has a unique infimum in the point  $z_+ = (0, z_+^1)$ ,  $z_+^1 > 0$  which is defined by the following equation

$$J^*(x - z) = \beta_2, \quad z = (0, z_+^1).$$

In the first case

$$\mathcal{L}_{0,x} = F(0) = \alpha^*(x)x^0 + \beta^*(x)x^1$$

and the optimal path from 0 to  $x$  is linear

$$\varphi(t) = \frac{t}{\tau^*(x)}x, \quad t \in [0, \tau^*]$$

In the second case

$$\mathcal{L}_{0,x} = \alpha_1 x^0 + \beta_1 x^1$$

where  $\alpha_1$  is defined by the system ( 56) and the optimal path from 0 to  $x$  is piecewise linear

$$\varphi(t) = \begin{cases} \frac{t}{\tau_-^\theta} z_- & \text{if } 0 \leq t \leq \tau_-^\theta, \\ z_- + \frac{t - \tau_-^\theta}{\tau_-^*} (x - z_-) & \text{if } \tau_-^\theta \leq t \leq \tau_-^\theta + \tau_-^* \end{cases}$$

where  $z_- = (0, z_-^1)$ ,  $z_-^1 < 0$ ,  $\tau_-^\theta > 0$ ,  $\tau_-^* > 0$  are defined by the system

$$\begin{cases} \nabla H_{\{1\}}^{1,1}(\alpha_1, \beta_1) = \frac{x - z_-}{\tau_-^*}, \\ \partial_3 \mathcal{H}_\theta^{1,1}(\beta_1) = \frac{z_-^1}{\tau_-^\theta}. \end{cases}$$

In the case (iii)

$$\mathcal{L}_{0,x} = \alpha_2 x^0 + \beta_2 x^1$$

where  $\alpha_2$  is defined by the system ( 57) and the optimal path from 0 to  $x$  is piecewise linear

$$\varphi(t) = \begin{cases} \frac{t}{\tau_+^\theta} z_+ & \text{if } 0 \leq t \leq \tau_+^\theta, \\ z_+ + \frac{t - \tau_+^\theta}{\tau_+^*} (x - z_+) & \text{if } \tau_+^\theta \leq t \leq \tau_+^\theta + \tau_+^* \end{cases}$$

where  $z_+ = (0, z_+^1)$ ,  $z_+^1 > 0$ ,  $\tau_+^\theta > 0$ ,  $\tau_+^* > 0$  are defined by the system

$$\begin{cases} \nabla H_{\{1\}}^{1,1}(\alpha_2, \beta_2) = \frac{x - z_+}{\tau_+^*}, \\ \partial_3 \mathcal{H}_\theta^{1,1}(\beta_2) = \frac{z_+^1}{\tau_+^\theta}. \end{cases}$$

The theorem 3.5.4 is proved.

**Theorem 3.5.5** *Let (54) be satisfied. Then for any  $x = (x^0, x^1) \in R_+^1 \times R^1$  the following conclusions hold.*

(i) *Let  $\beta_1 \leq \beta^*(-x) \leq \beta_2$  then*

$$\mathcal{L}_{x,0} = -\alpha^*(-x)x^0 - \beta^*(-x)x^1$$

*and the optimal path from  $x$  to 0 is linear*

$$\varphi(t) = x - \frac{t}{\tau^*(-x)}x, \quad t \in [0, \tau^*(-x)],$$

(ii) *Let  $\beta^*(-x) < \beta_1$ , then*

$$\mathcal{L}_{x,0} = -\alpha_1^\zeta x^0 - \beta_1 x^1$$

*where  $\alpha_1^\zeta$  is defined by the system*

$$\begin{cases} H_{\{1\}}^{1,1}(\alpha_1^\zeta, \beta_1) = 0, \\ \partial_\alpha H_{\{1\}}^{1,1}(\alpha_1^\zeta, \beta_1) < 0 \end{cases}$$

*and the optimal path from  $x$  to 0 is piecewise linear*

$$\varphi(t) = \begin{cases} x + \frac{t}{\tau_+^*}(z_+ - x) & \text{if } 0 \leq t \leq \tau_+^*. \\ z_+ - \frac{t - \tau_+^*}{\tau_+^\emptyset}z_+ & \text{if } \tau_+^* \leq t \leq \tau_+^\emptyset + \tau_+^* \end{cases}$$

*where  $z_+ = (0, z_+^1)$ ,  $z_+^1 > 0$ ,  $\tau_+^\emptyset > 0$ ,  $\tau_+^* > 0$  are defined by the system*

$$\begin{cases} \nabla H_{\{1\}}^{1,1}(\alpha_1^\zeta, \beta_1) = \frac{z_+ - x}{\tau_+^*}, \\ \partial_\beta \mathcal{H}_\emptyset^{1,1}(\beta_1) = \frac{-z_+^1}{\tau_+^\emptyset}. \end{cases}$$

(iii) *Let  $\beta_2 < \beta^*(-x)$ , then*

$$\mathcal{L}_{x,0} = -\alpha_2^\zeta x^0 - \beta_2 x^1$$

where  $\alpha_2^\zeta$  is defined by the system

$$\begin{cases} H_{\{1\}}^{1,1}(\alpha_2^\zeta, \beta_2) = 0, \\ \partial_\alpha H_{\{1\}}^{1,1}(\alpha_2^\zeta, \beta_2) < 0 \end{cases}$$

and the optimal path from  $x$  to 0 is piecewise linear

$$\tilde{\gamma}(t) = \begin{cases} x + \frac{t}{\tau_-^*}(z_- - x) & \text{if } 0 \leq t \leq \tau_-^*, \\ z_- - \frac{t - \tau_-^*}{\tau_-^\theta} z_- & \text{if } \tau_-^* \leq t \leq \tau_-^\theta + \tau_-^* \end{cases}$$

where  $z_- = (0, z_-^1)$ ,  $z_-^1 < 0$ ,  $\tau_-^\theta > 0$ ,  $\tau_-^* > 0$  are defined by the system

$$\begin{cases} \nabla H_{\{1\}}^{1,1}(\alpha_2^\zeta, \beta_2) = \frac{z_- - x}{\tau_-^*}, \\ \partial_\beta \mathcal{H}_\emptyset^{1,1}(\beta_2) = -\frac{-z_-^1}{\tau_-^\theta}. \end{cases}$$

One can easily prove this theorem using the same argument as in the proof of the theorem 3.5.4.

### 3.6 Stationary probabilities for an ergodic random walk in $Z_+^2$

Let us consider a random walk  $S_t(i, j)$ ,  $t \in Z_+$  in  $Z_+^2$ , starting at the point  $(i, j) \in Z_+^2$ :

$$S_0(i, j) = (i, j)$$

and having the transition probabilities as defined in the section 2.2. We do not assume here that  $d = 1$ .

Consider the following functions

$$H(\alpha, \beta) = \log \left\{ \sum_{(i,j)} p_{ij} \exp\{\alpha i + \beta j\} \right\}$$

$$h_1(\alpha, \beta) = \log \left\{ \sum_{(i,j)} p'_{ij} \exp\{\alpha i + \beta j\} \right\}$$

$$h_2(\alpha, \beta) = \log\left\{\sum_{i,j} p_{ij}'' \exp\{\alpha i + \beta j\}\right\}$$

For any  $\alpha$  let us consider  $\beta_0(\alpha)$  such that

$$\partial_\beta H(\alpha, \beta_0(\alpha)) = 0.$$

and for any  $\beta$  let us consider  $\alpha_0(\beta)$  such that

$$\partial_\alpha H(\alpha_0(\beta), \beta) = 0.$$

Consider

$$\mathcal{H}_{\{1\}}(\alpha) = \begin{cases} H(\alpha, \beta_0(\alpha)) & \text{if } H(\alpha, \beta_0(\alpha)) \geq h_1(\alpha, \beta_0(\alpha)) \\ H(\alpha, \beta(\alpha)) & \text{otherwise,} \end{cases}$$

where  $\beta(\alpha)$  is defined from the system

$$\begin{cases} H(\alpha, \beta) = h_1(\alpha, \beta(\alpha)) \\ \partial_\beta H(\alpha, \beta(\alpha)) < 0 \end{cases} \quad (60)$$

Consider also

$$\mathcal{H}_{\{2\}}(\beta) = \begin{cases} H(\alpha_0(\beta), \beta) & \text{if } H(\alpha_0(\beta), \beta) \geq h_2(\alpha_0(\beta), \beta) \\ H(\alpha(\beta), \beta) & \text{otherwise,} \end{cases}$$

where  $\alpha(\beta)$  is defined from the system

$$\begin{cases} H(\alpha(\beta), \beta) = h_2(\alpha(\beta), \beta) \\ \partial_\alpha H(\alpha(\beta), \beta) < 0 \end{cases} \quad (61)$$

Let  $L(\cdot)$ ,  $L_1(\cdot)$ ,  $L_2(\cdot)$  be the Legendre transforms of the functions  $H(\cdot)$ ,  $\mathcal{H}_{\{1\}}(\cdot)$ ,  $\mathcal{H}_{\{2\}}(\cdot)$  correspondingly. Consider the following function

$$L((i, j), v) = \begin{cases} L_{1,2}(v) & \text{if } i > 0, j > 0 \\ L_1(v^1) & \text{if } i > 0, j = 0 \\ L_2(v^2) & \text{if } i = 0, j > 0 \\ 0 & \text{if } i = j = 0 \end{cases}$$

where  $v = (V^1, v^2)$ .

From the large deviation principle for the random walk in  $Z_+^1 \times Z^1$  (3.3.1) it easily follows the large deviation principle for an ergodic random walk in  $Z_+^2$ . For the transient case in the quarter plane there is an open problem for the path identically equal to  $(0, 0)$ . We do not touch this case in our paper.

**Theorem 3.6.1** *Let the random walk  $S_t$  be ergodic. Then it satisfies the large deviation principle with the action functionals  $\mathcal{L}_\tau$  such that for any  $\tau \geq 0$  and for any continuous path*

$$\varphi : [0, \tau] \rightarrow R_+^2$$

$$\mathcal{L}_\tau(\varphi) = \int_0^\tau L(\varphi(t), \dot{\varphi}(t)) dt$$

if the path  $\varphi$  is absolutely continuous, and

$$\mathcal{L}_\tau(\varphi) = \infty$$

otherwise.

Let the random walk  $S_t$  be ergodic. Consider the stationary probabilities  $\pi(x)$ ,  $x \in Z_+^2$  of this random walk. Using the large deviation principle we shall get now a logarithmic asymptotics of  $\pi(\{x^N\})$  as  $N \rightarrow \infty$  for any  $x \in R_+^2$ .

We shall assume here that

( $H_0$ ):

(0) The Markov chain corresponding to the random walk  $S_t$  is irreducible and aperiodic.

(1) The induced Markov chain with the set of states  $Z_+$  and transition probabilities

$$p_1(l, l') = \sum_{k'} p((1, l) \rightarrow (1 + k', l'))$$

is irreducible and aperiodic :

(2) The same for the other induced Markov chain with transition probabilities

$$p_2(k, k') = \sum_{l'} p((k, 1) \rightarrow (k', 1 + l'))$$

( $H$ ):

$$\nabla H(0, 0) \neq 0,$$

$$\begin{aligned}\frac{d}{d\alpha} \mathcal{H}_{\{1\}}(0) &\neq 0 \\ \frac{d}{d\beta} \mathcal{H}_{\{2\}}(0) &\neq 0\end{aligned}$$

Using the same arguments as in the section 3.5 one can easily show that for any two point there exists an optimal path from one point to another. Consider for any  $x \in R_+^2$  an optimal path to go from the point 0 to the point  $x$

$$\varphi_x : [0, \tau_x] \rightarrow R_+^2$$

and consider

$$\mathcal{L}_{0,x} = \mathcal{L}_{\tau_x}(\varphi_x)$$

**Theorem 3.6.2** For any  $x \in R_+^2$

$$\lim_{N \rightarrow \infty} \frac{1}{N} \log \pi([xN]) = -\mathcal{L}_{0,x}$$

**Proof.**

It's easy to see that:

$$\pi([xN]) \geq \pi(0)P(S_{N\tau}(0) = [xN])$$

Using the lower bound for the last factor we obtain the following bound:

$$\frac{1}{N} \log \pi([xN]) \geq -\mathcal{L}_{0,x} - \varepsilon \quad (62)$$

To get the upper bound:

$$\frac{1}{N} \log \pi([xN]) \leq -\mathcal{L}_{0,x} + \varepsilon$$

we consider the interval  $[0, Nr + N\tau]$  for some large  $r$  and  $\tau \geq \tau_x$ , where  $\tau_x$  is the time of optimal way from point 0 to point  $x$ .

Let  $\gamma_0$  be the last moment of time when random walk hits 0, such that

$$\gamma_0 \in [1, 1 + Nr + N\tau]$$

Then we have:

$$P(S_{1+Nr+N\tau}(0) = [xN]) = \sum_{k=1}^{Nr} P(\gamma_0 = k), \quad (63)$$

$$S_{1+Nr+N\tau}(0) = [xN]) + P(\gamma_0 \geq 1 + Nr, S_{1+Nr+N\tau}(0) = [xN])$$

Let us note that for each term of first sum we have:

$$\frac{1}{N} \log(P(\gamma_0 = k, S_{1+Nr+N\tau}(0) = [xN])) \leq -\mathcal{L}_{0,x} + \varepsilon \quad (64)$$

for  $N \geq N(\varepsilon)$ , and  $N(\varepsilon)$  doesn't depend from  $k$ . In order to estimate the second term in ( 63) we note that for our case of ergodic random walk in quarter of plane the following bound takes place:

$$P(\gamma_0 \geq Nr) \leq \exp(-\alpha rN), \quad (65)$$

$-\alpha$  is some fixed constant. The upper bound ( 65) was proved in ([5]). Note that  $r$  may be taken sufficiently large. Then keeping in mind exponential convergence to the stationary measure we can obtain the upper bound for  $\frac{1}{N} \log \pi([xN])$  by simple reasoning. Thus the statement of theorem 3.6.2 is proved.

■

Let us calculate for any  $x \in R_+^2$  the value  $\mathcal{L}_{0,x}$ . For this let us consider the system

$$\begin{cases} H(\alpha, \beta) = 0, \\ \tau \nabla H(\alpha, \beta) = x, \\ \tau > 0. \end{cases} \quad (66)$$

For any  $x \in R_+^2$  there exists a unique solution of this system  $\alpha^*(x), \beta^*(x), \tau^*(x)$ .

Consider also the following equations

$$\mathcal{H}_{\{1\}}(\alpha) = 0 \quad (67)$$

and

$$\mathcal{H}_{\{2\}}(\beta) = 0 \quad (68)$$

Due to the convexity of the functions  $\mathcal{H}_{\{1\}}(\cdot)$  and  $\mathcal{H}_{\{2\}}(\cdot)$  from the assumptions ( $H$ ) it follows that each of these equations has exactly two different solutions. Let  $\alpha_{\{1\}}^1 < \alpha_{\{1\}}^2$  and  $\beta_{\{2\}}^1 < \beta_{\{2\}}^2$  be the solutions of the equations ( 67), and ( 68) correspondingly. One can easily show that

$$\alpha_{\{1\}}^1 \leq 0 \leq \alpha_{\{1\}}^2$$



$$\beta_{\{2\}}^1 \leq 0 \leq \beta_{\{2\}}^2$$

$$\frac{d}{d\alpha} \mathcal{H}_{\{1\}}(\alpha_{\{1\}}^1) < 0, \quad \frac{d}{d\alpha} \mathcal{H}_{\{1\}}(\alpha_{\{1\}}^2) > 0$$

and

$$\frac{d}{d\beta} \mathcal{H}_{\{2\}}(\beta_{\{2\}}^1) < 0, \quad \frac{d}{d\beta} \mathcal{H}_{\{2\}}(\beta_{\{2\}}^2) > 0$$

**Theorem 3.6.3** For any  $x \in R_+^2$  the following conclusions hold

(i) Let  $\alpha^*(x) \leq \alpha_{\{1\}}^2$  and  $\beta^*(x) \leq \beta_{\{2\}}^2$  then

$$\mathcal{L}_{0,x} = \alpha^*(x)x^1 + \beta^*(x)x^2$$

and the optimal path from 0 to  $x$  is linear

$$\varphi_x(t) = \frac{t}{\tau^*(x)}x, \quad t \in [0, \tau^*(x)],$$

(ii) Let  $\alpha^*(x) > \alpha_{\{1\}}^2$  and  $\beta^*(x) \leq \beta_{\{2\}}^2$  then

$$\mathcal{L}_{0,x} = \alpha_{\{1\}}^2 x^1 + \beta_{\{1\}}^2 x^2$$

where  $\beta_{\{1\}}^2$  is defined by the system

$$\begin{cases} H(\alpha_{\{1\}}^2, \beta_{\{1\}}^2) = 0, \\ \partial_\beta H(\alpha_{\{1\}}^2, \beta_{\{1\}}^2) \geq 0 \end{cases} \quad (69)$$

For  $x^2 = 0$  the optimal path from 0 to  $x$  is linear

$$\varphi_x^1(t) = \frac{t}{\tau^1}x, \quad t \in [0, \tau^1],$$

where  $\tau^1 > 0$  is defined from the equation

$$\frac{d}{d\alpha} \mathcal{H}_{\{1\}}(\alpha_{\{1\}}^2) = \frac{x^1}{\tau^1}.$$

For  $x^2 > 0$  the optimal path from 0 to  $x$  is piecewise linear

$$\varphi_x^1(t) = \begin{cases} \frac{t}{\tau_1^1} z_1 & \text{if } 0 \leq t \leq \tau_1^1, \\ z_1 + \frac{t - \tau_1^1}{\tau_1^2} (x - z_1) & \text{if } \tau_1^1 \leq t \leq \tau_1^1 + \tau_1^2 \end{cases}$$

where  $z_1 = (z_1^1, 0)$ ,  $z_1^1 > 0$ ,  $\tau_1^1 > 0$ ,  $\tau_1^2 > 0$  are defined from the system

$$\begin{cases} \nabla H(\alpha_{\{1\}}^2, \beta_{\{1\}}^2) = \frac{x - z_1}{\tau_1^2}, \\ \frac{d}{d\alpha} \mathcal{H}_{\{1\}}(\alpha_{\{1\}}^2) = \frac{z_1^1}{\tau_1^2}. \end{cases}$$

(iii) Let  $\alpha^*(x) \leq \alpha_{\{1\}}^2$  and  $\beta^*(x) > \beta_{\{2\}}^2$  then

$$\mathcal{L}_{0,x} = \alpha_{\{2\}}^2 x^1 + \beta_{\{2\}}^2 x^2$$

where  $\alpha_{\{2\}}^2$  is defined by the system

$$\begin{cases} H(\alpha_{\{2\}}^2, \beta_{\{2\}}^2) = 0, \\ \frac{\partial}{\partial \alpha} H(\alpha_{\{2\}}^2, \beta_{\{2\}}^2) \geq 0 \end{cases} \quad (70)$$

For  $x^1 = 0$  the optimal path from 0 to  $x$  is linear

$$\varphi_x^2(t) = \frac{t}{\tau_2^2} x, \quad t \in [0, \tau_2^2],$$

where  $\tau_2^2 > 0$  is defined from the equation

$$\frac{d}{d\beta} \mathcal{H}_{\{2\}}(\beta_{\{2\}}^2) = \frac{x^2}{\tau_2^2}.$$

For  $x^1 > 0$  the optimal path from 0 to  $x$  is piecewise linear

$$\varphi_x^2(t) = \begin{cases} \frac{t}{\tau_1^2} z_2 & \text{if } 0 \leq t \leq \tau_1^2, \\ z_2 + \frac{t - \tau_1^2}{\tau_2^2} (x - z_2) & \text{if } \tau_1^2 \leq t \leq \tau_1^2 + \tau_2^2 \end{cases}$$

where  $z_2 = (0, z_2^2)$ ,  $z_2^2 > 0$ ,  $\tau_2^1 > 0$ ,  $\tau_2^2 > 0$  are defined from the system

$$\begin{cases} \nabla H(\alpha_{\{2\}}^2, \beta_{\{2\}}^2) = \frac{x - z_2}{\tau_2^2}, \\ \frac{d}{d\beta} \mathcal{H}_{\{2\}}(\beta_{\{2\}}^2) = \frac{z_2^2}{\tau_2^2}. \end{cases}$$

(iv) Let  $\alpha^*(x) > \alpha_{\{1\}}^2$  and  $\beta^*(x) > \beta_{\{2\}}^2$ , then

$$\mathcal{L}_{0,x} = \min\{\alpha_{\{1\}}^2 x^1 + \beta_{\{1\}}^2 x^2, \alpha_{\{2\}}^2 x^1 + \beta_{\{2\}}^2 x^2\}$$

and the optimal path from 0 to  $x$  is the following

$$\varphi_x(t) \equiv \begin{cases} \varphi_x^1(t) & \text{if } \alpha_{\{1\}}^2 x^1 + \beta_{\{1\}}^2 x^2 > \alpha_{\{2\}}^2 x^1 + \beta_{\{2\}}^2 x^2 \\ \varphi_x^2(t) & \text{if } \alpha_{\{1\}}^2 x^1 + \beta_{\{1\}}^2 x^2 > \alpha_{\{2\}}^2 x^1 + \beta_{\{2\}}^2 x^2 \end{cases}$$

One can easily prove this theorem using the same arguments as in the proof of the theorem 3.5.4.

It is useful to consider the following conditions which are equivalent to the conditions (i),(ii),(iii) and (iv) of the theorem 3.6.3

1.  $\sim$  (i)  $h_1(\alpha^*(x), \beta^*(x)) \leq 0, \quad h_2(\alpha^*(x), \beta^*(x)) \leq 0.$
2.  $\sim$  (ii)  $h_1(\alpha^*(x), \beta^*(x)) > 0, \quad h_2(\alpha^*(x), \beta^*(x)) \leq 0.$
3.  $\sim$  (iii)  $h_1(\alpha^*(x), \beta^*(x)) \leq 0, \quad h_2(\alpha^*(x), \beta^*(x)) > 0.$
4.  $\sim$  (iv)'  $h_1(\alpha^*(x), \beta^*(x)) > 0, \quad h_2(\alpha^*(x), \beta^*(x)) > 0$

This equivalence easily follows from the definition of the functions  $\mathcal{H}_{\{1\}}$  and  $\mathcal{H}_{\{2\}}$ .

Let us give geometric interpretation to the conditions (i) - (iv). For this let us introduce the polar coordinates in  $R_+^2 \setminus \{0\}$ .

$$x^1 = r(x) \cos \gamma(x), \quad x^2 = r(x) \sin \gamma(x)$$

$$r(x) > 0, \quad 0 \leq \gamma(x) \leq \frac{\pi}{2}.$$

Let us consider  $0 \leq \gamma_1 \leq \frac{\pi}{2}$  and  $0 \leq \gamma_2 \leq \frac{\pi}{2}$  such that

$$tg \gamma_1 = \frac{\frac{\partial}{\partial \beta} H(\alpha_{\{1\}}^2, \beta_{\{1\}}^2)}{\frac{\partial}{\partial \alpha} H(\alpha_{\{1\}}^2, \beta_{\{1\}}^2)}$$

and

$$\operatorname{tg} \gamma_2 = \frac{\frac{\partial}{\partial \beta} H(\alpha_{\{2\}}^2, \beta_{\{2\}}^2)}{\frac{\partial}{\partial \alpha} H(\alpha_{\{2\}}^2, \beta_{\{2\}}^2)}$$

Note that for any  $x \in R_+^2$

$$\alpha^*(x) = \alpha_{\{1\}}^2 \iff \gamma(x) = \gamma_1,$$

$$\beta^*(x) = \beta_{\{2\}}^2 \iff \gamma(x) = \gamma_2,$$

and moreover

$$\alpha^*(x) < \alpha_{\{1\}}^2 \iff \gamma(x) > \gamma_1,$$

$$\alpha^*(x) > \alpha_{\{1\}}^2 \iff \gamma(x) < \gamma_1,$$

$$\beta^*(x) < \beta_{\{2\}}^2 \iff \gamma(x) < \gamma_2,$$

$$\beta^*(x) > \beta_{\{2\}}^2 \iff \gamma(x) > \gamma_2.$$

Due to the theorem 3.6.3 for any  $x \in R_+^2$  the following conclusions hold.

(i) Let  $\gamma_1 \leq \gamma(x) \leq \gamma_2$ . Then the optimal path from the point 0 to the point  $x$  is linear.

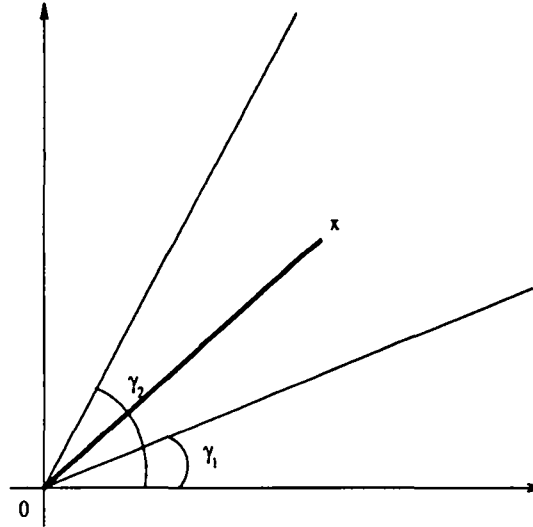

(ii) Let  $\gamma(x) < \gamma_1$  and  $\gamma(x) \leq \gamma_2$ . Then the optimal path from the point 0 to the point  $x$  is the piecewiselinear path  $\varphi_1$  consisting of two linear segments:

the optimal path from 0 to  $z_1 = (z^1, 0)$  and the optimal path from  $z_1$  to  $x$ , where  $z_1 = (z^1, 0)$ ,  $z^1 > 0$  is uniquely defined by the equality

$$\gamma(x - z_1) = \gamma_1$$

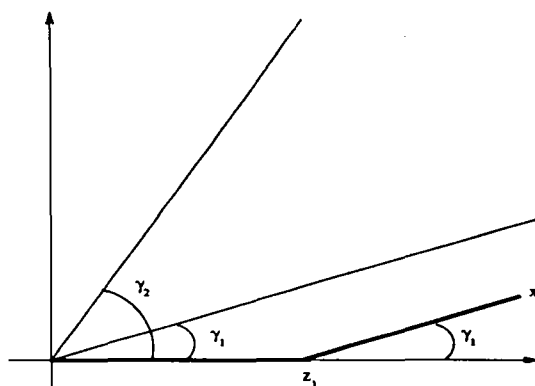

(iii) Let  $\gamma(x) \geq \gamma_1$  and  $\gamma(x) > \gamma_2$ . Then the optimal path from the point 0 to the point  $x$  is the piecewiselinear path  $\varphi_2$  consisting of two linear segments: the optimal path from 0 to  $z_2 = (0, z^2)$  and the optimal path from  $z_2$  to  $x$ , where  $z_2 = (0, z^2)$ ,  $z^2 > 0$  is uniquely defined by the equality

$$\gamma(x - z_2) = \gamma_2$$

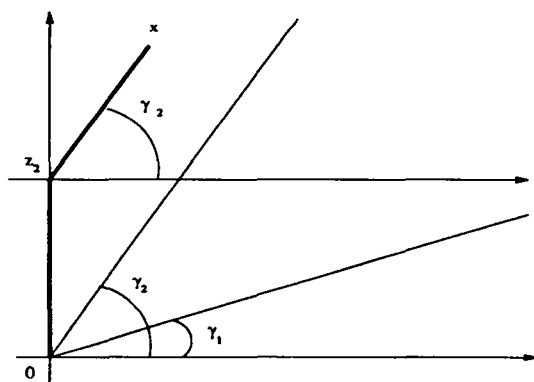

(iv) Let  $\gamma(x) < \gamma_1$  and  $\gamma(x) > \gamma_2$ . Then the optimal path from the point 0 to the point  $x$  is the path  $\varphi_x^1$  or  $\varphi_x^2$  which provides the minimum of the action functional.

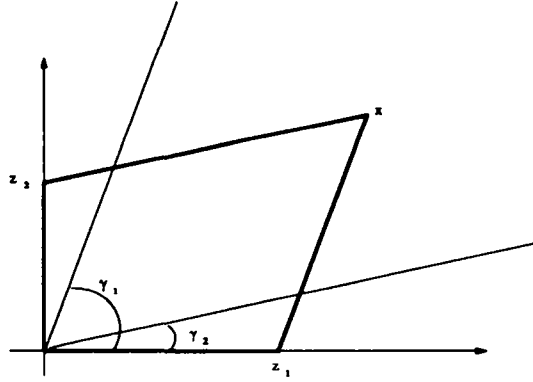

Define the sets

$$\mathcal{P}_{--} = \{x \in \mathbb{R}_+^2 : \gamma_1 \leq \gamma(x) \leq \gamma_2\}$$

$$\mathcal{P}_{+-} = \{x \in \mathbb{R}_+^2 : \gamma(x) < \gamma_1, \gamma(x) \leq \gamma_2\}$$

$$\mathcal{P}_{-+} = \{x \in \mathbb{R}_+^2 : \gamma_1 \leq \gamma(x), \gamma_2 < \gamma(x)\}$$

$$\mathcal{P}_{++} = \{x \in \mathbb{R}_+^2 : \gamma(x) < \gamma_1, \gamma_2 < \gamma(x)\}$$

From theorem 3.6.3 it follows

**Theorem 3.6.4** For any  $x \in \mathbb{R}_+^2$

$$\frac{1}{N} \log \pi([Nx]) \sim -\min\{\alpha_{\{1\}}^2(x)x^1 + \beta_{\{1\}}^2(x)x^2, \alpha_{\{2\}}^2(x)x^1 + \beta_{\{2\}}^2(x)x^2\}$$

if  $x \in \mathcal{P}_{++}$  and

$$\frac{1}{N} \log \pi([Nx]) \sim \begin{cases} -\alpha^*(x)x^1 - \beta^*(x)x^2 & \text{if } x \in \mathcal{P}_{--} \\ -\alpha_{\{1\}}^2(x)x^1 - \beta_{\{1\}}^2(x)x^2 & \text{if } x \in \mathcal{P}_{+-} \\ -\alpha_{\{2\}}^2(x)x^1 - \beta_{\{2\}}^2(x)x^2 & \text{if } x \in \mathcal{P}_{-+} \end{cases}$$

One can see that these results coincide with the results of the theorem 2.2.1. It is suggestive to find deeper connections between analytic and probabilistic approaches.

## 4 Appendix.

### 4.1

Let us consider a countable Markov chain with a set of states  $X$  and transition probabilities  $p_{i,j}$ ,  $i, j \in X$ .

We shall assume that the following conditions are satisfied

$D$ :

- (i) This Markov chain is irreducible and aperiodic.
- (ii) There exist functions  $f : X \rightarrow \mathbb{R}_+$  and  $k : X \rightarrow \mathbb{Z}_+$  such that
  - (a) for any  $b > 0$

$$\sum_{j \in X} \exp\{-bf(j)\} < \infty$$

- (b) there exists  $d > 0$  such that for any  $i, j \in X$

$$p_{i,j} = 0 \text{ if } |f(j) - f(i)| > d$$

- (c)

$$\sup_i k(i) < \infty$$

- (d) there exists a finite subset  $X_0 \subset X$  such that for any  $i \in X \setminus X_0$

$$\sum_j p_{i,j}^{(k(i))} f(j) \leq f(i) - \epsilon$$

where  $\epsilon$  does not depend on  $i \in X \setminus X_0$ .

From these assumptions it follows (see [5] ) that this Markov chain is ergodic and moreover the two following propositions hold.

1. for any  $h > 0$  there exist  $c > 0$  and  $h' > 0$  such that for any  $i, j \in X$  and for any  $t \in \mathbb{Z}_+$

$$p_{i,j}^{(t)} \leq ce^{hf(i)-h'f(j)} \quad (71)$$

2. for any  $h > 0$  there exist  $c > 0$  and  $\alpha > 0$ , such that for any  $i \in X$  and for any  $t \in \mathbb{Z}_+$

$$\sum_{j \in X} |p_{i,j}^{(t)} - \pi(j)| \leq ce^{hf(i)-\alpha t} \quad (72)$$

where  $\pi(j)$ ,  $j \in X$  are the stationary probabilities for this Markov chain.

Let consider a Markov chain having the set of states  $Z_+$  and transition probabilities  $p_{i,j}$ ,  $i, j \in Z_+$  such that

$$p_{i,j} = p_{j-i} \text{ and } \sum_j p_{j-i}(j-i) < 0$$

for all  $i > d_1$ , and

$$p_{i,j} = 0 \text{ if } |j-i| > d_2$$

with some positive constants  $d_1, d_2$ . Then this Markov chain in ergodic and satisfies the conditions  $D$  with the following functions

$$f(j) = j \text{ and } k(j) = 1, j \in Z_+$$

The Markov chain with the set of states  $Z^1$  and transition probabilities  $p_{i,j}$ ,  $i, j \in Z^1$  such that

$$p_{i,j} = p_{+,j-i} \text{ and } \sum_j p_{+,j-i}(j-i) < 0 \text{ for all } i > d_1 > 0,$$

$$p_{i,j} = p_{-,j-i} \text{ and } \sum_j p_{-,j-i}(j-i) > 0 \text{ for all } i < -d_1 < 0,$$

and

$$p_{i,j} = 0 \text{ if } |j-i| > d_2$$

with some positive constants  $d_1, d_2$ , is also ergodic and satisfies the conditions  $D$ .

These two examples are trivial. To get not trivial examples one can consider the almost homogeneous random walk in  $Z_+^r$  satisfying some additional conditions (see [1], [4], and [5] for examples ).

Let  $\xi_t(i)$ ,  $i \in X$ , be a random walk in  $X$  corresponding to our Markov chain starting at the point  $i$ .

**Theorem 4.1.1 Kolmogorov inequality** *Let  $V_t(i, j), i, j \in X, t \in Z_+$ , be independent random vectors with the values in  $R^\mu$ , such that for any  $i, j \in X$  the vectors  $V_t(i, j), t \in Z_+$  are identically distributed and*

$$\|V_t(i, j)\| \leq C_0 < \infty \text{ a.s} \tag{73}$$

where  $C_0 > 0$  does not depend on  $i, j$ .



Then for any  $i \in X$  there exists  $c = c(i) > 0$  such that for any  $\delta > 0$  and for any  $T \in Z_+$

$$P\left\{ \sup_{\tau=1, \dots, T} \left\| \sum_{n=0}^{\tau} V_n(\xi_n(i), \xi_{n+1}(i)) - EV_n(\xi_n(i), \xi_{n+1}(i)) \right\| > \delta T \right\} \leq \frac{c}{\delta^2 T} \quad (74)$$

To prove this theorem we shall need the following

**Lemma 4.1.1** For any  $i \in X$  there exist  $c_1 > 0$  and  $\alpha_1 > 0$  such that for any  $n, m \in Z_+$

$$\begin{aligned} & | E(V_n(\xi_n(i), \xi_{n+1}(i)) - EV_n(\xi_n(i), \xi_{n+1}(i)), V_m(\xi_m(i), \xi_{m+1}(i)) - \\ & - EV_m(\xi_m(i), \xi_{m+1}(i))) | \leq c_1 e^{-\alpha_1 |n-m|} \end{aligned} \quad (75)$$

where  $(\cdot, \cdot)$  is a scalar product in  $R^\mu$ ,

$$(x, y) = \sum_{j=1}^{\mu} x^j y^j, \quad x, y \in R^\mu.$$

**Proof of lemma 4.1.1**

Let  $i \in X$  be fixed, and

$$V_n = V_n(\xi_n(i), \xi_{n+1}(i)), \quad a_n = EV_n, \quad n \in Z_+.$$

For any  $n, m \in Z_+, n > m$ , one can easily get

$$\begin{aligned} E(V_n - a_n, V_m - a_m) &= \sum_{i', i'' \in X} p_{i, i'}^{(m)} p_{i', i''} \times \\ &\times \sum_{j', j'' \in X} (p_{i'', j'}^{(n-m-1)} - \pi(j')) p_{j', j''} \times \\ &\times (EV_m(i', i'') - a_m, EV_n(j', j'') - a_n) \end{aligned} \quad (76)$$

From 76 by 73 it follows that

$$| E(V_n - a_n, V_m - a_m) | \leq 4C_0^2 \sum_{i', j' \in X} p_{i', i'}^{(m+1)} \times \quad (77)$$

$$\cdot | p_{i', j'}^{(n-m-1)} - \pi(j') |$$

From ( 77), ( 71) and ( 72) one can easily get ( 75).  
 Lemma 4.1.1 is proved.

■

**Proof of theorem 4.1.1**

Let  $i \in X$  be fixed,  $V_n = V_n(\xi_n(i), \xi_{n+1}(i))$ ,

$$a_n = EV_n \text{ and } S_n = \sum_{j=0}^n (V_j - a_j), n \in Z_+ .$$

For given  $\delta > 0$  and  $T \in Z_+$  let us consider the following events

$$A_n = \{ \| S_{n+1} \| > \delta T, \| S_0 \| < \delta T, \dots, \| S_n \| < \delta T \} , n = 0, \dots, T.$$

Let  $I_n$  be an indicator of the event  $A_n$ . Then

$$E \| S_t \|^2 \geq \sum_{n=0}^{t-1} \| S_n \|^2 - 2 \sum_{n=0}^{t-1} \sum_{j=n+1}^{t-1} | E(S_n I_n, V_j - a_j) | = J_1(t) - J_2(t) \quad (78)$$

**Lemma 4.1.2** *There exists  $C > 0$  such that for any  $t$*

$$J_2(t) \leq C \quad (79)$$

**Proof.** From ( 78) and ( 73) it follows that for any  $h > 0$  there exists  $C_1 > 0$  such that

$$\sum_{j=n+1}^{t-1} | E(S_n I_n, V_j - a_j) | \leq C_1 E(| S_n | I_n \exp\{h\xi_x^\Lambda(n)\}) \quad (80)$$

Note that due to ( 73)

$$I_n = 0 \text{ a.s. for } n \leq \frac{\delta t}{2C_0} \quad (81)$$

Then from ( 73),( 80) and ( 81) we get

$$I_2 \leq C_1 \sum_{n=\theta t}^{t-1} n E(I_n \exp\{h\xi_x^\Lambda(n)\}) \quad (82)$$

where  $\theta = \frac{\delta}{2C_0}$ .

Consider the following event

$$B_n = \{\xi_x^\Lambda(n) > \epsilon t\}$$

Let  $I_{B_n}$  be its indicator. Consider

$$J_2'(t) = \sum_{n=\theta t}^{t-1} n E(I_{A_n} I_n \exp\{h\xi_x^\Lambda(n)\})$$

$$J_2''(t) = \sum_{n=\theta t}^{t-1} n E((1 - I_{A_n}) I_n \exp\{h\xi_x^\Lambda(n)\})$$

For  $J_2''(t)$  for small  $\epsilon > 0$  one can easily get

$$J_2'' \leq \sum_{n=\theta t}^{t-1} n E(I_n \exp\{\epsilon t\}) \leq C_2 \exp(-\beta t) \quad (83)$$

because of

$$E(I_n) \leq C_2' \exp(-\beta' t)$$

For  $J_2'$  we have

$$J_2' \leq \sum_{n=\theta t}^{t-1} n E(I_{A_n} \exp\{h\xi_x^\Lambda(n)\}) \leq C_3 \exp(-\gamma t) \quad (84)$$

because of

$$E(\exp(h\xi_x^\Lambda(n))) < \infty$$

for small  $h > 0$ .

From ( 82),( 83) and ( 84) it follows ( 79).

Lemma 4.1.2 is proved.

■

From ( 78) using lemma 4.1.1 we get

$$E \| S_t \|^2 \geq \sum_{n=0}^{t-1} E \| S_n \|^2 I_n - C \quad (85)$$

where  $c' = c'(x) > 0$ .

Let us note now that

$$\sum_{n=0}^{t-1} E \| S_n \|^2 I_n \geq \delta^2 t^2 P\{ \max_{n=1, \dots, t} \| S_n \| > \epsilon t \} \quad (86)$$

From ( 85) and ( 86) we get

$$P\{ \max_{n=1, \dots, t} \| S_n \| > \epsilon t \} \leq \frac{E \| S_t \|^2 + C}{\epsilon^2 t^2} \quad (87)$$

Let us now estimate the value  $E \| S_t \|^2$ .

$$E \| S_t \|^2 \leq \sum_{j=1}^t E \| V_j - a_j \|^2 + 2 \sum_{j=1}^t \sum_{e=j+1}^t | E(V_j - a_j, V_e - a_e) | \quad (88)$$

From ( 88) using ( 73) and lemma 4.1.1 we get

$$E \| S_t \|^2 \leq c'' t, \quad (89)$$

where  $c'' = c''(x) > 0$

From ( 87) and ( 89) we get ( 74)

The theorem 4.1.1 is proved.

■

From the theorem 4.1.1 by the ergodicity of the chain  $\mathcal{L}_\wedge$  it easily follows

**Theorem 4.1.2** *Let the conditions of theorem 4.1.1 be satisfied, and*

$$V = \sum_{i, j \in X} \pi_i p_{i, j} E V_0(i, j).$$

*Then for any  $i \in X$  there exists  $c = c(i) > 0$  such that for any  $\delta > 0$  and for any  $t \in Z_+$  the following estimation holds*

$$P\{ \sup_{\tau=1, \dots, t} \left\| \sum_{n=0}^{\tau} V_n(\xi_n(i), \xi_{n+1}(i)) - V\tau \right\| > \delta t \} \leq \frac{c}{\delta^2 t} \quad (90)$$

## References

- [1] V.A.Malyshev. "Networks and Dynamical Systems". Adv. Appl. Probab., 25, pp.140-175, 1993.
- [2] P.Dupuis and R.Ellis. "Large deviations for Markov Processes with discontinuous statistics,II: random walks". Probab.Theory Relat. Fields ,91, pp.153-194, 1992.
- [3] P.Dupuis, H.Ishii and H.Mete Soner. "A viscosity solution approach to the asymptotic analysis of queueing systems". The Annals of Probability , 18, No.1, pp. 226-255. 1990.
- [4] I.Ignatyuk, V.Malyshev. " Classification of Random Walks in  $Z_+^4$  ". Selecta Mathematica (formerly Sovietica), Vol.12, No. 2, pp. 129-194, 1993.
- [5] V.Malyshev, M.V.Menshikov. "Ergodicity, continuity and analyticity of countable Markov chains", Trans. Moscow Math. Soc. v.39, pp. 3- 48, 1979.
- [6] V.Malyshev. " Asymptotic behaviour of stationary probabilities for two dimensional positive random walks", Siberian Math. Journal, v. 14. No. 1, pp. 156-169, 1972.
- [7] A.Venttsel. "Limit theorems on Large Deviations for Markov stochastic processes". Kluwer Academic Press. 1990.
- [8] J.-D. Deuschel, D.W.Stroock. Large Deviations. Acad.Press,Inc.1989.
- [9] R.S.Ellis. "Entropy, Large Deviations, and Statistical Mechanics." Springer-Verlag.1985.
- [10] R.L.Dobrushin. "Analyticity of correlation functions in one-dimensional classical systems with slowly decreasing potentials." Comm.Math.Phis., vol.32, 1973, 269-289.
- [11] M.Campanino, D.Capocaccia, E.Olivieri. "Analyticity for one-dimensional systems with long-range superstable interactions. J.Statist. Phis., vol.33, No.2, 1983, 437-476.



---

Unité de Recherche INRIA Rocquencourt  
Domaine de Voluceau - Rocquencourt - B.P. 105 - 78153 LE CHESNAY Cedex (France)  
Unité de Recherche INRIA Lorraine Technopôle de Nancy-Brabois - Campus Scientifique  
615, rue du Jardin Botanique - B.P. 101 - 54602 VILLERS LES NANCY Cedex (France)  
Unité de Recherche INRIA Rennes IRISA, Campus Universitaire de Beaulieu 35042 RENNES Cedex (France)  
Unité de Recherche INRIA Rhône-Alpes 46, avenue Félix Viallet - 38031 GRENOBLE Cedex (France)  
Unité de Recherche INRIA Sophia Antipolis 2004, route des Lucioles - B.P. 93 - 06902 SOPHIA ANTIPOLIS Cedex (France)

---

EDITEUR  
INRIA - Domaine de Voluceau - Rocquencourt - B.P. 105 - 78153 LE CHESNAY Cedex (France)

ISSN 0249 - 6399



★ R R . 1 9 9 9 ★