



Weakened conditions of admissibility of surface forces applied to linearly elastic membrane shells

Robert Luce, Cécile Poutous, Jean-Marie Thomas

► To cite this version:

Robert Luce, Cécile Poutous, Jean-Marie Thomas. Weakened conditions of admissibility of surface forces applied to linearly elastic membrane shells. *Analysis and Applications*, World Scientific Publishing, 2008, 6 (3), pp.247-267. inria-00341897

HAL Id: inria-00341897

<https://hal.inria.fr/inria-00341897>

Submitted on 26 Nov 2008

HAL is a multi-disciplinary open access archive for the deposit and dissemination of scientific research documents, whether they are published or not. The documents may come from teaching and research institutions in France or abroad, or from public or private research centers.

L'archive ouverte pluridisciplinaire **HAL**, est destinée au dépôt et à la diffusion de documents scientifiques de niveau recherche, publiés ou non, émanant des établissements d'enseignement et de recherche français ou étrangers, des laboratoires publics ou privés.

Weakened conditions of admissibility of surface forces applied to linearly elastic membrane shells

Robert Luce, Cécile Poutous, Jean-Marie Thomas

robert.luce@univ-pau.fr, cecile.poutous@univ-pau.fr, jean-marie.thomas@univ-pau.fr

Laboratoire de Mathématiques Appliquées, UMR 5142, Université de Pau et des Pays de l'Adour, BP 1155, 64013 Pau Cedex, France

Abstract

We consider a family of linearly elastic shells of the first kind (as defined in Ciarlet [2]), also known as non inhibited pure bending shells (Sanchez-Hubert and Sanchez-Palencia [7]). This family is indexed by the half-thickness ε . When ε approaches zero, the averages across the thickness of the shell of the covariant components of the displacement of the points of the shell converge strongly towards the solution of a "2D generalized membrane shell problem" provided the applied forces satisfy admissibility conditions (Ciarlet and Lods [3], Chapelle and Bathe [1]). The identification of the admissible applied forces usually requires delicate analysis.

In the first part of this paper we simplify the general admissibility conditions when applied forces \mathbf{h} are surface forces only, and obtain conditions that no longer depend on ε (Luce, Poutous and Thomas [5]) : find $h^{\alpha\beta} = h^{\beta\alpha}$ in $L^2(\omega)$ such that for all $\eta = (\eta_i)$ in $\mathbf{V}(\omega)$, $\int_{\omega} h^i \eta_i d\omega = \int_{\omega} h^{\alpha\beta} \gamma_{\alpha\beta}(\eta) d\omega$ where ω is a domain of \mathbb{R}^2 , θ is in $C^3(\bar{\omega}, \mathbb{R}^3)$ and $S = \theta(\bar{\omega})$ is the middle surface of the shells, where $(\gamma_{\alpha\beta}(\eta))$ is the linearized strain tensor of S and $\mathbf{V}(\omega) = \{\eta \in \mathbf{H}^1(\omega), \eta = \mathbf{0} \text{ on } \gamma_0\}$, the shells being clamped along $\Gamma_0 = \theta(\gamma_0)$.

In the second part, since the simplified admissibility formulation does not allow to conclude directly to the existence of $h^{\alpha\beta}$, we seek sufficient conditions on \mathbf{h} for $h^{\alpha\beta}$ to exist in $L^2(\omega)$. In order to get them, we impose more regularity to $h^{\alpha\beta}$ and boundary conditions. Under these assumptions, we can obtain from the weak formulation a system of PDE with $h^{\alpha\beta}$ as unknowns. The existence of solutions depends both on the geometry of the shell and on the choice of \mathbf{h} . We carry through the study of four representative geometries of shells and identify in each case a special admissibility functional space for \mathbf{h} .

1 Introduction and notations

In this paper, greek indices take their values in $\{1, 2\}$, whereas latin indices belong to $\{1, 2, 3\}$ and the repeated index summation convention is used.

Let us first consider the "2D" ill-posed scaled variational problem

$$\mathcal{P}(\omega) : \begin{cases} \zeta \in \mathbf{V}(\omega) := \{\eta = (\eta_i) \in \mathbf{H}^1(\omega); \eta = \mathbf{0} \text{ on } \gamma_0\}, \forall \eta \in \mathbf{V}(\omega) \\ \int_{\omega} a^{\alpha\beta\sigma\tau} \gamma_{\sigma\tau}(\zeta) \gamma_{\alpha\beta}(\eta) \sqrt{a} dy = \int_{\omega} h^i v_i \sqrt{a} dy \end{cases}$$

where the bilinear form is not coercive on $\mathbf{V}(\omega)$, the surface functions $h^i \in L^2(\omega)$ are independent of ε , ω is a domain in \mathbb{R}^2 (open, bounded, connected subset with a Lipschitz-continuous boundary, the set ω being locally on one side of its boundary), $\theta : \bar{\omega} \rightarrow \mathbb{R}^3$ ($\theta \in C^3(\bar{\omega}; \mathbb{R}^3)$) is an injective mapping such that the two vectors $\mathbf{a}_\alpha := \partial_\alpha \theta(y)$ are linearly independent at each point $y \in \bar{\omega}$, where $\mathbf{a}_3 := \frac{\mathbf{a}_1 \wedge \mathbf{a}_2}{|\mathbf{a}_1 \wedge \mathbf{a}_2|}$, and $a_{\alpha\beta} := \mathbf{a}_\alpha \cdot \mathbf{a}_\beta$ denote the covariant components of the metric tensor of $S := \theta(\bar{\omega})$, and $a := \det((a_{\alpha\beta})_{\alpha\beta})$, $a^{\alpha\beta}$ denote the contravariant components of the metric tensor of

$S := \theta(\bar{\omega})$, where $a^{\alpha\beta\sigma\tau}$ which denote the contravariant components of the scaled 2D elasticity tensor are defined by

$$a^{\alpha\beta\sigma\tau} := \frac{4\lambda\mu}{\lambda + 2\mu} a^{\alpha\beta} a^{\sigma\tau} + 2\mu (a^{\alpha\sigma} a^{\beta\tau} + a^{\alpha\tau} a^{\beta\sigma}) \quad \text{with } \lambda > 0, \mu > 0$$

where $\Gamma_{\alpha\beta}^\sigma$ are the surface Christoffel symbols i.e. $\Gamma_{\alpha\beta}^\sigma := \mathbf{a}^\sigma \cdot \partial_\alpha \mathbf{a}_\beta$ with $\mathbf{a}^i \cdot \mathbf{a}_j = \delta_{ij}$, and where, for any vector field $\eta = (\eta_i) \in \mathbf{H}^1(\omega)$, the covariant components of the 2D linearized change of metric tensor $\gamma_{\alpha\beta}(\eta) \in L^2(\omega)$ are defined by

$$\gamma_{\alpha\beta}(\eta) := \frac{1}{2} (\partial_\beta \eta_\alpha + \partial_\alpha \eta_\beta) - \Gamma_{\alpha\beta}^\sigma \eta_\sigma - b_{\alpha\beta} \eta_3 \quad \text{with } b_{\alpha\beta} := \mathbf{a}_3 \cdot \partial_\alpha \mathbf{a}_\beta. \quad (1)$$

Let us also consider the 3D scaled variational problem

$$\mathcal{P}(\varepsilon; \Omega) : \begin{cases} \mathbf{u}(\varepsilon) \in \mathbf{V}(\Omega) := \{\mathbf{v} = (v_i) \in \mathbf{H}^1(\Omega); \mathbf{v} = \mathbf{0} \text{ on } \Gamma_0 := \gamma_0 \times [-1, 1]\}, \forall \mathbf{v} \in \mathbf{V}(\Omega) \\ \int_\Omega A^{ijkl}(\varepsilon) e_{k||l}(\varepsilon; \mathbf{u}(\varepsilon)) e_{i||j}(\varepsilon; \mathbf{v}) \sqrt{g(\varepsilon)} dx = \int_{\Gamma^+ \cup \Gamma^-} h^{i\pm} v_i \sqrt{g(\varepsilon)} d\Gamma \end{cases} \quad (2)$$

where the functions $h^{i\pm} \in L^2(\Gamma^+ \cup \Gamma^-)$ are independent of ε , $\Omega := \omega \times]-1, 1[$, $\Gamma^+ := \omega \times \{1\}$, $\Gamma^- := \omega \times \{-1\}$, and $\Omega_\varepsilon := \omega \times]-\varepsilon, \varepsilon[$, $\Theta : \bar{\Omega}_\varepsilon \rightarrow \mathbb{R}^3$ is the canonical extension of θ and thus verifies $\Theta(y, x_3) := \theta(y) + x_3 a_3$ and $\det(\mathbf{g}_1, \mathbf{g}_2, \mathbf{g}_3) > 0$ (where $\mathbf{g}_i := \partial_i \Theta$), where, for any vector field $\mathbf{v} = (v_i) \in \mathbf{H}^1(\Omega)$, the scaled linearized strains $e_{i||j}(\varepsilon; \mathbf{v}) = e_{j||i}(\varepsilon; \mathbf{v}) \in \mathbf{L}^2(\Omega)$ are defined by

$$e_{\alpha||\beta}(\varepsilon; \mathbf{v}) := \frac{1}{2} (\partial_\beta v_\alpha + \partial_\alpha v_\beta) - \Gamma_{\alpha\beta}^p(\varepsilon) v_p \\ e_{\alpha||3}(\varepsilon; \mathbf{v}) := \frac{1}{2} \left(\frac{1}{\varepsilon} \partial_3 v_\alpha + \partial_\alpha v_3 \right) - \Gamma_{\alpha 3}^\sigma(\varepsilon) v_\sigma, \quad e_{3||3}(\varepsilon; \mathbf{v}) := \frac{1}{\varepsilon} \partial_3 v_3$$

with $\Gamma_{ij}^p(\varepsilon) : \bar{\Omega} \rightarrow \mathbb{R}$ being the scaled 3D Christoffel symbols i.e.

$$\Gamma_{ij}^p(\varepsilon)(x_1, x_2, x_3) := \Gamma_{ij}^{\varepsilon,p}(x_1, x_2, \varepsilon x_3) \quad \text{and} \quad \Gamma_{ij}^{\varepsilon,p} := \mathbf{g}^p \cdot \partial_i \mathbf{g}_j \quad \text{with } \mathbf{g}^i \cdot \mathbf{g}_j = \delta_{ij},$$

with also, $g(\varepsilon) : \bar{\Omega} \rightarrow \mathbb{R}$ being the scaled function of $g^\varepsilon := \det(\mathbf{g}_i \cdot \mathbf{g}_j)$, i.e. $g(\varepsilon)(x_1, x_2, x_3) := g^\varepsilon(x_1, x_2, \varepsilon x_3)$, and where, at last, the contravariant components $A^{ijkl}(\varepsilon) : \bar{\Omega} \rightarrow \mathbb{R}$ of the scaled 3D elasticity tensor satisfy

$$A^{ijkl}(\varepsilon) = A^{jikl}(\varepsilon) = A^{klij}(\varepsilon), \quad A^{ijkl}(\varepsilon) = A^{ijkl}(0) + O(\varepsilon) \quad \text{and} \quad A^{\alpha\beta\sigma 3}(\varepsilon) = A^{\alpha 333}(\varepsilon) = 0,$$

where the order symbol is meant with respect to the norm $\|w\|_{0,\infty,\bar{\Omega}} := \sup\{|w(x)|, x \in \bar{\Omega}\}$ and

$$A^{\alpha\beta\sigma\tau}(0) : = \lambda a^{\alpha\beta} a^{\sigma\tau} + \mu (a^{\alpha\sigma} a^{\beta\tau} + a^{\alpha\tau} a^{\beta\sigma}), \quad A^{\alpha\beta 33}(0) := \lambda a^{\alpha\beta}, \quad A^{\alpha 333}(0) := \mu a^{\alpha\sigma} \\ A^{3333}(0) : = \lambda + 2\mu, \quad A^{\alpha\beta\sigma 3}(0) = A^{\alpha 333}(0) := 0.$$

Let us now assume that the semi norm $|\cdot|_\omega^M$ defined by $|\eta|_\omega^M := (\sum_{\alpha,\beta} |\gamma_{\alpha\beta}(\eta)|_{0,\omega}^2)^{1/2}$ is a norm over the space $\mathbf{V}(\omega)$ which

is not equivalent to the norm $\|\cdot\|_{1,\omega}$ (Slicaru [9]) and let $\mathbf{V}_M^\#(\omega)$ be the completion of $\mathbf{V}(\omega)$ with respect to $|\cdot|_\omega^M$. Let $|\cdot|_\Omega^M$ be the norm over $\mathbf{V}(\Omega)$ defined by

$$|\mathbf{v}|_\Omega^M = \left\{ |\partial_3 \mathbf{v}|_{0,\Omega}^2 + \left(|\bar{\mathbf{v}}|_\omega^M \right)^2 \right\}^{1/2} \quad \text{where } \bar{\mathbf{v}} := \frac{1}{2} \int_{-1}^1 \mathbf{v} dx_3$$

and let $\mathbf{V}_M^\#(\Omega)$ be the completion of $\mathbf{V}(\Omega)$ with respect to $|\cdot|_\Omega^M$.

Let $B_M(\zeta, \eta) := \int_\omega a^{\alpha\beta\sigma\tau} \gamma_{\sigma\tau}(\zeta) \gamma_{\alpha\beta}(\eta) \sqrt{a} dy$ and $L_M(\eta) := \int_\omega h^i \eta_i \sqrt{a} dy$ and let $B_M^\#$ and $L_M^\#$ denote the unique continuous extensions from $\mathbf{V}(\omega)$ to $\mathbf{V}_M^\#(\omega)$ of the bilinear form B_M and the linear form L_M .

Under all these assumptions, Ph. Ciarlet and V. Lods proved that

Theorem 1 *There exist \mathbf{u} in $\mathbf{V}_M^\#(\Omega)$ and ζ in $\mathbf{V}_M^\#(\omega)$ such that*

$$\mathbf{u}(\varepsilon) \longrightarrow \mathbf{u} \text{ in } \mathbf{V}_M^\#(\Omega) \text{ as } \varepsilon \rightarrow 0 \text{ and } \overline{\mathbf{u}(\varepsilon)} \longrightarrow \zeta \text{ in } \mathbf{V}_M^\#(\omega) \text{ as } \varepsilon \rightarrow 0.$$

and the limit ζ satisfies the scaled 2D variational problem of a linearly elastic generalized membrane shell of the first kind

$$\mathcal{P}_{\mathcal{M}}^\#(\omega) : \begin{cases} \zeta \in \mathbf{V}_M^\#(\omega), \forall \eta \in \mathbf{V}_M^\#(\omega) \\ B_M^\#(\zeta, \eta) = L_M^\#(\eta) \end{cases} \quad (3)$$

if the density of surface force \mathbf{h} is admissible, that is, if there exist for each ε , $0 < \varepsilon < \varepsilon_0$, functions $F^{ij}(\varepsilon) = F^{ji}(\varepsilon) \in L^2(\Omega)$ and there exist functions $F^{ij} = F^{ji} \in L^2(\Omega)$ such that $F^{ij}(\varepsilon) \longrightarrow F^{ij}$ in $L^2(\Omega)$ as $\varepsilon \rightarrow 0$ and

$$\int_{\Gamma^+ \cup \Gamma^-} h^{i\pm} v_i \sqrt{g(\varepsilon)} d\Gamma = \int_{\Omega} F^{ij}(\varepsilon) e_{i||j}(\varepsilon; \mathbf{v}) \sqrt{g(\varepsilon)} dx \text{ for all } 0 < \varepsilon < \varepsilon_0 \text{ and for all } \mathbf{v} \in \mathbf{V}(\Omega).$$

Remark 1 *Because of the previous strong convergency results, it seems natural to carry on with the study of admissibility conditions. But it is not the only option, an alternative is to study the behaviour of the solution $\mathbf{u}(\varepsilon)$ when the forces are not admissible. V. Lods and C. Mardare have proved in [4] that, provided the shell is totally clamped, the solutions $\mathbf{u}(\varepsilon)$ strongly converge, in the energy norm, towards the displacement given by Koiter or Naghdi's models.*

2 Main results

In what follows we assume that all the assumptions above are satisfied. Let us now simplify the second part of the previous theorem and prove that

Theorem 2 *There exist \mathbf{u} in $\mathbf{V}_M^\#(\Omega)$ and ζ in $\mathbf{V}_M^\#(\omega)$ such that*

$$\mathbf{u}(\varepsilon) \longrightarrow \mathbf{u} \text{ in } \mathbf{V}_M^\#(\Omega) \text{ as } \varepsilon \rightarrow 0 \text{ and } \overline{\mathbf{u}(\varepsilon)} \longrightarrow \zeta \text{ in } \mathbf{V}_M^\#(\omega) \text{ as } \varepsilon \rightarrow 0$$

and the limit ζ satisfies the scaled 2D variational problem $\mathcal{P}_{\mathcal{M}}^\#(\omega)$ if there exist functions $h^{\alpha\beta} = h^{\beta\alpha} \in L^2(\omega)$ such that the density of surface force \mathbf{h} satisfies :

$$\int_{\omega} h^i \eta_i \sqrt{a} dy = \int_{\omega} h^{\alpha\beta} \gamma_{\alpha\beta}(\eta) \sqrt{a} dy \text{ for all } \eta \in \mathbf{V}(\omega). \quad (4)$$

The proof is given for a density applied on the upper surface so that we can identify $h^{i\pm}$ with h^i . The general case is then proved by linearity. In Ciarlet and Lods [3], the proof is divided in ten parts. To prove our theorem, we keep the same pattern of proof. But we only have to change the proof of parts (ii), (iii), (v) and (vii) since these are the parts concerned with the admissibility of the forces. The proof of the other parts remains unchanged. For a better understanding of the whole proof, we remind them and use their results when required.

Before proving **Theorem 2**, let us first remind two usefull propositions already proved in Ciarlet [2].

Proposition 1 *We have the following 3D Inequality of Korn's type : there exist constants $C > 0$ and $\varepsilon_0 > 0$ such that*

$$\|\mathbf{v}\|_{1,\Omega} \leq \frac{C}{\varepsilon} \left\{ \sum_{i,j} \|e_{i||j}(\varepsilon; \mathbf{v})\|_{0,\Omega}^2 \right\}^{1/2} \text{ for all } \mathbf{v} \in \mathbf{V}(\Omega) \text{ and all } 0 < \varepsilon < \varepsilon_0. \quad (5)$$

Proposition 2 *If $w \in L^2(\Omega)$ satisfies*

$$\int_{\Omega} w \partial_3 v dx = 0 \text{ for all } v \in H^1(\Omega) \text{ that vanish on } \Gamma_0, \text{ then } w = 0. \quad (6)$$

We now prove two preliminary results that will be used in the proof of **Theorem 2**.

Lemma 1 For $v \in H^1(\Omega)$, let $v_{|\Gamma^+}$ denote the trace of v on Γ^+ and \bar{v} denote the mean value of v in the thickness. Then we have

$$v_{|\Gamma^+} = \bar{v} + \frac{1}{2} \int_{-1}^1 (1+x_3) \partial_3 v dx_3. \quad (7)$$

Proof. The result is obtained after the following integration by parts:

$$\begin{aligned} \bar{v} &= \frac{1}{2} \int_{-1}^1 v dx_3 = \frac{1}{2} \left(\int_{-1}^1 \partial_3 ((1+x_3)v) dx_3 - \int_{-1}^1 (1+x_3) \partial_3 v dx_3 \right) \\ &= \frac{1}{2} \left((1+1)v_{|\Gamma^+} - (1-1)v_{|\Gamma^-} - \int_{-1}^1 (1+x_3) \partial_3 v dx_3 \right). \end{aligned}$$

■

Lemma 2 There exist constants $c > 0$, $\varepsilon_0 > 0$ and a function $G(\varepsilon, x_1, x_2, x_3)$ such that for all $0 < \varepsilon < \varepsilon_0$,

$$\sqrt{g(\varepsilon)} = \sqrt{a} + \varepsilon G \text{ with } \|G\|_{0,\infty,\bar{\Omega}} \leq c \quad (8)$$

Proof. In Ciarlet [2], p156, it is proved that $g_{\alpha\beta}(\varepsilon) = a_{\alpha\beta} - 2\varepsilon x_3 b_{\alpha\beta} + O(\varepsilon^2)$. Then, since $g(\varepsilon) = \det((g_{ij}(\varepsilon))_{i,j})$ and $a = \det((a_{\alpha\beta})_{\alpha\beta})$, we have the result by using a first order Taylor development. ■

We can now give the proof of **Theorem 2**.

Proof.

Part (i): (no proof) There exist constants $c_0 > 0$ and $\varepsilon_0 > 0$ such that

$$|\mathbf{v}|_{\Omega}^M \leq c_0 \left\{ \sum_{i,j} \|e_{i\|j}(\varepsilon; \mathbf{v})\|_{0,\Omega}^2 \right\}^{1/2} \text{ for all } \mathbf{v} \in \mathbf{V}(\Omega) \text{ and all } 0 < \varepsilon < \varepsilon_0. \quad (9)$$

Part (ii): (partial proof) There is a subsequence, still denoted $(\mathbf{u}(\varepsilon))_{\varepsilon > 0}$ for convenience, and there exist $\mathbf{u} \in \mathbf{V}_M^\#(\Omega)$, $\mathbf{u}^{-1} = (u_i^{-1}) \in \mathbf{V}(\Omega)$, $e_{i\|j} \in L^2(\Omega)$, and $\zeta \in \mathbf{V}_M^\#(\omega)$ such that

$$\begin{aligned} \mathbf{u}(\varepsilon) &\rightharpoonup \mathbf{u} && \text{in } \mathbf{V}_M^\#(\Omega), \\ \varepsilon \mathbf{u}(\varepsilon) &\rightharpoonup \mathbf{u}^{-1} && \text{in } \mathbf{H}^1(\Omega), \\ e_{i\|j}(\varepsilon) &\rightharpoonup e_{i\|j} && \text{in } L^2(\Omega), \\ \varepsilon e_{3\|3}(\varepsilon) &\longrightarrow e_{3\|3} && \text{in } L^2(\Omega), \\ \mathbf{u}(\varepsilon) &\rightharpoonup \zeta && \text{in } \mathbf{V}_M^\#(\omega) \text{ as } \varepsilon \rightarrow 0. \end{aligned}$$

In order to prove that, it is sufficient to prove that there exist constants $c > 0$ and $\varepsilon_1 > 0$ such that for all $0 < \varepsilon < \varepsilon_1$,

$$\left| \int_{\Gamma^+} h^{i+} u_i(\varepsilon) \sqrt{g(\varepsilon)} d\Gamma \right| \leq c \left\{ \sum_{i,j} \|e_{i\|j}(\varepsilon)\|_{0,\Omega}^2 \right\}^{1/2}.$$

From (8) we know that

$$\int_{\Gamma^+} h^{i+} u_i(\varepsilon) \sqrt{g(\varepsilon)} d\Gamma = \int_{\Gamma^+} h^{i+} u_i(\varepsilon) \sqrt{a} d\Gamma + \int_{\Gamma^+} h^{i+} u_i(\varepsilon) \varepsilon G d\Gamma. \quad (10)$$

Then, with the help of (4) and (7), we can write the first integral of the righthside of (10) this way:

$$\int_{\Gamma^+} h^{i+} u_i(\varepsilon) \sqrt{a} d\Gamma = \int_{\omega} h^{\alpha\beta} \gamma_{\alpha\beta}(\bar{\mathbf{u}}(\varepsilon)) \sqrt{a} dy + \frac{1}{2} \int_{\Omega} (1+x_3) \mathbf{h} \partial_3 \mathbf{u}(\varepsilon) \sqrt{a} dx.$$

Hence, applying Cauchy-Schwarz inequality first, using the definition of $|\mathbf{u}(\varepsilon)|_\Omega^M$ afterwards, and lastly using (9) we have the following inequalities

$$\begin{aligned} \left| \int_{\Gamma^+} h^{i+} u_i(\varepsilon) \sqrt{a} d\Gamma \right| &\leq \|h^{\alpha\beta} \sqrt{a}\|_{0,\omega} \left\| \gamma_{\alpha\beta} \left(\overline{\mathbf{u}(\varepsilon)} \right) \right\|_{0,\omega} + \frac{1}{2} \|(1+x_3) \mathbf{h} \sqrt{a}\|_{0,\Omega} \|\partial_3 \mathbf{u}(\varepsilon)\|_{0,\Omega} \\ &\leq c |\mathbf{u}(\varepsilon)|_\Omega^M \leq c \left\{ \sum_{i,j} \|e_{i||j}(\varepsilon)\|_{0,\Omega}^2 \right\}^{1/2}. \end{aligned}$$

At this point, let us insist on the fact that the $h^{\alpha\beta}$ have to be in $L^2(\omega)$ which can be more restrictive than \mathbf{h} being in the dual of $\mathbf{V}_M^\#(\omega)$. That is why, the results obtained by E. Sanchez-Palencia in [8] and [7] about this space are not enough to insure the convergence of $\overline{\mathbf{u}(\varepsilon)}$. To majorate the second integral of the righthside of (10), we use again the Cauchy-Schwarz inequality, then the continuity of the trace on Γ^+ and the majoration of (8), we conclude with inequality (5). Therefore,

$$\left| \int_{\Gamma^+} h^{i+} u_i(\varepsilon) \varepsilon G d\Gamma \right| \leq \varepsilon \|\mathbf{h}^+ G\|_{0,\Gamma^+} \|\mathbf{u}(\varepsilon)\|_{0,\Gamma^+} \leq c\varepsilon \|\mathbf{u}(\varepsilon)\|_{0,\Omega} \leq c\varepsilon \|\mathbf{u}(\varepsilon)\|_{1,\Omega} \leq c \left\{ \sum_{i,j} \|e_{i||j}(\varepsilon)\|_{0,\Omega}^2 \right\}^{1/2}.$$

Part (iii): (proof) The limits $e_{i||j}$ found in part (ii) satisfy

$$e_{1||3} = 0, \quad e_{2||3} = 0 \quad \text{and} \quad e_{3||3} = -\frac{\lambda}{\lambda + 2\mu} a^{\alpha\beta} e_{\alpha||\beta}.$$

In $\mathcal{P}(\varepsilon; \Omega)$ we let $\mathbf{v} := \varepsilon \mathbf{w}$, \mathbf{w} being an arbitrary function in the space $\mathbf{V}(\Omega)$, and we let ε approach zero; we obtain the equation

$$\int_{\Omega} \{2\mu a^{\alpha\sigma} e_{\sigma||3} \partial_3 w_\alpha + (\lambda a^{\sigma\tau} e_{\sigma||\tau} + (\lambda + 2\mu) e_{3||3} \partial_3 w_3)\} \sqrt{a} dx = 0,$$

which, combined with (6), implies the result.

Part (iv): (no proof) The whole family $(\mathbf{u}(\varepsilon))_{\varepsilon>0}$ satisfies:

$$\left\{ \overline{e_{\alpha||\beta}(\varepsilon)} - \gamma_{\alpha\beta} \left(\overline{\mathbf{u}(\varepsilon)} \right) \right\} \longrightarrow 0 \text{ in } L^2(\omega) \text{ as } \varepsilon \rightarrow 0;$$

consequently, the subsequence considered in part (ii) satisfies:

$$\gamma_{\alpha\beta} \left(\overline{\mathbf{u}(\varepsilon)} \right) \rightharpoonup \overline{e_{\alpha||\beta}} \text{ in } L^2(\omega).$$

Part (v): (partial proof) The limits $e_{\alpha||\beta}$ found in part (ii) satisfy

$$\int_{\omega} a^{\alpha\beta\sigma\tau} \overline{e_{\sigma||\tau}} \gamma_{\alpha\beta}(\eta) \sqrt{a} dy = \int_{\omega} h^{\alpha\beta} \gamma_{\alpha\beta}(\eta) \sqrt{a} dy \text{ for all } \eta \in \mathbf{V}(\omega),$$

the functions $h^{\alpha\beta} \in L^2(\omega)$ being those used in the definition of admissible forces in **Theorem 2**. To prove the previous equation, we just need to check that

$$\int_{\omega} h^{\alpha\beta} \gamma_{\alpha\beta}(\mathbf{v}) \sqrt{a} dy = \lim_{\varepsilon \rightarrow 0} \int_{\Gamma^+} h^{i+} v_i \sqrt{g(\varepsilon)} d\Gamma \text{ for all } \mathbf{v} \in \mathbf{V}(\Omega) \text{ independent of the transverse variable.}$$

A function $\mathbf{v} \in \mathbf{V}(\Omega)$ independent of the transverse variable x_3 satisfies $\partial_3 \mathbf{v} = \mathbf{0}$. That is why, using the same decomposition as in the proof of part (ii), we have

$$\int_{\Gamma^+} h^{i+} v_i \sqrt{g(\varepsilon)} d\Gamma = \int_{\omega} h^{\alpha\beta} \gamma_{\alpha\beta}(\mathbf{v}) \sqrt{a} dy + \varepsilon \int_{\Gamma^+} h^{i+} v_i G d\Gamma$$

and the expected result when we let $\varepsilon \rightarrow 0$.

Part (vi): (no proof) The subsequence $(\mathbf{u}(\varepsilon))_{\varepsilon>0}$ found in part (ii) is such that

$$\begin{aligned}\varepsilon \mathbf{u}(\varepsilon) &\rightarrow \mathbf{0} \text{ in } \mathbf{H}^1(\Omega), \\ \partial_3 u_\alpha(\varepsilon) &\rightarrow 0 \text{ in } L^2(\Omega),\end{aligned}$$

as $\varepsilon \rightarrow 0$. Furthermore, $e_{\alpha\|\beta}$ is independent of the transverse variable x_3 .

Part (vii): (partial proof) The following strong convergences hold as $\varepsilon \rightarrow 0$:

$$\begin{aligned}e_{i\|j}(\varepsilon) &\rightarrow e_{i\|j} \text{ in } L^2(\Omega), \\ \varepsilon \mathbf{u}(\varepsilon) &\rightarrow \mathbf{0} \text{ in } \mathbf{H}^1(\Omega), \\ \gamma_{\alpha\beta}(\overline{\mathbf{u}(\varepsilon)}) &\rightarrow \overline{e_{\alpha\|\beta}} \text{ in } L^2(\omega), \\ \overline{\mathbf{u}(\varepsilon)} &\rightarrow \zeta \text{ in } \mathbf{V}_M^\#(\omega).\end{aligned}$$

To prove part (vii), we only need to prove the following result

$$\lim_{\varepsilon \rightarrow 0} \int_{\Gamma^+} h^{i+} u_i(\varepsilon) \sqrt{g(\varepsilon)} d\Gamma = \int_{\omega} h^{\alpha\beta} \overline{e_{\alpha\|\beta}} \sqrt{a} dy.$$

From the proof of part (ii), we know that

$$\int_{\Gamma^+} h^{i+} u_i(\varepsilon) \sqrt{g(\varepsilon)} d\Gamma = \int_{\omega} h^{\alpha\beta} \gamma_{\alpha\beta}(\overline{\mathbf{u}(\varepsilon)}) \sqrt{a} dy + \frac{1}{2} \int_{\Omega} (1+x_3) \mathbf{h} \partial_3 \mathbf{u}(\varepsilon) \sqrt{a} dx + \int_{\Gamma^+} h^{i+} \varepsilon u_i(\varepsilon) G d\Gamma \quad (11)$$

and because of (vi), (iv) and (ii) we have:

$$\lim_{\varepsilon \rightarrow 0} \frac{1}{2} \int_{\Omega} (1+x_3) \mathbf{h} \partial_3 \mathbf{u}(\varepsilon) \sqrt{a} dx = 0, \lim_{\varepsilon \rightarrow 0} \int_{\omega} h^{\alpha\beta} \gamma_{\alpha\beta}(\overline{\mathbf{u}(\varepsilon)}) \sqrt{a} dy = \int_{\omega} h^{\alpha\beta} \overline{e_{\alpha\|\beta}} \sqrt{a} dy \text{ and } \lim_{\varepsilon \rightarrow 0} \int_{\Gamma^+} h^{i+} \varepsilon u_i(\varepsilon) G d\Gamma = 0.$$

Hence, we just have to let $\varepsilon \rightarrow 0$ in (11) to get the announced result.

Part (viii): (no proof) The limit $\zeta \in \mathbf{V}_M^\#(\omega)$ found in part (ii) satisfies the equations

$$B_M^\#(\zeta, \eta) = L_M^\#(\eta) \text{ for all } \eta \in \mathbf{V}_M^\#(\omega),$$

which have a unique solution. Consequently, the convergence

$$\overline{\mathbf{u}(\varepsilon)} \rightarrow \zeta \text{ in } \mathbf{V}_M^\#(\omega)$$

established in part (vii) holds for the whole family $(\overline{\mathbf{u}(\varepsilon)})_{\varepsilon>0}$.

Part (ix): (no proof) The following strong convergences hold:

$$\begin{aligned}\mathbf{u}(\varepsilon) &\rightarrow \mathbf{u} \text{ in } \mathbf{V}_M^\#(\Omega), \\ \partial_3 u_\alpha(\varepsilon) &\rightarrow 0 \text{ in } L^2(\Omega).\end{aligned}$$

Part (x): (no proof) The whole family $(\mathbf{u}(\varepsilon))_{\varepsilon>0}$ converges strongly to \mathbf{u} in the space $\mathbf{V}_M^\#(\Omega)$. ■

3 Some applications

In this section we first obtain a general system of PDE from the weak formulation (4), and afterwards, we carry through the study of this system in four representative cases. Since $(\gamma_{\alpha\beta})$, the linearized change of metric tensor of S , depends on the geometry of the shell through the Christoffel symbols $\Gamma_{\alpha\beta}^\sigma$ and the curvature tensor $(b_{\alpha\beta})$, see (1), the formulation

of the PDE system depends on the geometry too. The choice of the coordinates set is very important to simplify the coupling between the unknowns. Indeed, if the geometry is hyperbolic, a parametrisation along the asymptotic lines leads to the following curvature tensor : $(b_{\alpha\beta}) = \begin{pmatrix} 0 & b_{12} \\ b_{12} & 0 \end{pmatrix}$, whereas if the geometry is parabolic, the tensor becomes $(b_{\alpha\beta}) = \begin{pmatrix} b_{11} & 0 \\ 0 & 0 \end{pmatrix}$ when the first coordinate is along the asymptotic line (Sanchez-Hubert and Sanchez-Palencia [7]).

Let us remind that an asymptotic line of a surface S is a curve on S having the property that at every point, the tangent vector is collinear with one of the asymptotic directions (directions for which the normal curvature is null).

Theorem 3 *If the problem of unknowns $(h^{\alpha\beta})$ (with $h^{21} = h^{12}$):*

$$\begin{cases} -\partial_\beta(h^{\alpha\beta}\sqrt{a}) - \Gamma_{\sigma\beta}^\alpha(h^{\sigma\beta}\sqrt{a}) = h^\alpha\sqrt{a} & \text{for } \alpha = 1, 2 \\ -b_{11}h^{11} - 2b_{12}h^{12} - b_{22}h^{22} = h^3 \end{cases} \quad (12)$$

admits at least one solution such that

$$\begin{cases} h^{11} \in L^2(\omega), \partial_1 h^{11} \in L^2(\omega), h^{11}n_1 = 0 \text{ on } \partial\omega \setminus \gamma_0, \\ h^{22} \in L^2(\omega), \partial_2 h^{22} \in L^2(\omega), h^{22}n_2 = 0 \text{ on } \partial\omega \setminus \gamma_0, \\ h^{12} \in H^1(\omega), h^{12} = 0 \text{ on } \partial\omega \setminus \gamma_0 \end{cases} \quad (13)$$

then \mathbf{h} is admissible.

Proof. Let us assume that $h^{\alpha\beta}$ satisfy the regularity and boundary conditions (13). We integrate by part $\int_\omega h^{\alpha\beta}\gamma_{\alpha\beta}(\eta)\sqrt{a}dy$ with $\eta \in \mathbf{V}(\omega)$. The border integrals vanish because of the boundary conditions. By using the equations (12), we obtain $\int_\omega h^{\alpha\beta}\gamma_{\alpha\beta}(\eta)\sqrt{a}dy = \int_\omega h^i\eta_i\sqrt{a}dy$, so (4) is satisfied. ■

Before studying the existence of solutions for the PDE systems in four representative cases of partially or totally clamped, hyperbolic or parabolic shells, let us first remind two useful properties.

Property 1 *Let $\omega :=]a, b[\times]c, d[$ be an open bounded subset of \mathbb{R}^2 and h be a function of $L^2(\omega)$. The function f defined almost everywhere in ω by*

$$f(x, y) := \int_a^x h(t, y)dt$$

is in $L^2(\omega)$ and satisfies

$$\partial_x f = h \text{ in } L^2(\omega), \quad f = 0 \text{ on } x = a.$$

A proof is given in Sanchez-Hubert and Sanchez-Palencia [7], p64.

Property 2 *Let $\omega :=]a, b[\times]c, d[$ be an open bounded subset of \mathbb{R}^2 and h be a function of $L^2(\omega)$ such that $\partial_y h$ is in $L^2(\omega)$ too. Then, the function f defined almost everywhere in ω by*

$$f(x, y) := \int_a^x h(t, y)dt$$

is in $H^1(\omega)$ and satisfies

$$\partial_x f = h \text{ in } L^2(\omega), \quad \partial_y f = \int_a^x \partial_y h(t, y)dt \text{ in } L^2(\omega) \text{ and } f = 0 \text{ on } x = a.$$

Proof. Because of **Property 1**, we just need to prove that $\partial_y f = \int_a^x \partial_y h(t, y)dt$. To do so, we first prove the equality in the space of distributions $\mathcal{D}'(\omega)$, that is, we prove that for any φ in $\mathcal{D}(\omega)$:

$$\int_\omega \partial_y f(x, y)\varphi(x, y)dxdy = \int_\omega \left(\int_a^x \partial_y h(t, y)dt \right) \varphi(x, y)dxdy$$

Let φ be in $\mathcal{D}(\omega)$, h and $\partial_y h$ be in $L^2(\omega)$ and $f(x, y) := \int_a^x h(t, y) dt$. By definition of the derivation in $\mathcal{D}'(\omega)$ and by definition of f ,

$$\int_{\omega} \partial_y f(x, y) \varphi(x, y) dx dy = - \int_{\omega} f(x, y) \partial_y \varphi(x, y) dx dy = - \int_{\omega} \left(\int_a^x h(t, y) dt \right) \partial_y \varphi(x, y) dx dy$$

From the Ostrogradsky formula $\int_{\omega} \partial_x u v dx dy = - \int_{\omega} u \partial_x v dx dy + \int_{\partial\omega} u v \nu_x dl$, that can be used as soon as $\partial_x u$ and $\partial_x v$ are in $L^2(\omega)$, we deduce that

$$- \int_{\omega} \left(\int_a^x h(t, y) dt \right) \partial_y \varphi(x, y) dx dy = \int_{\omega} \left(\int_b^x \partial_y \varphi(t, y) dt \right) h(x, y) dx dy - \int_{\partial\omega} \left(\int_a^x h(t, y) dt \right) \left(\int_b^x \partial_y \varphi(t, y) dt \right) \nu_x dl$$

But, on the borders $y = c$ and $y = d$, $\nu_x = 0$, on the border $x = a$, $\int_a^x h(t, y) dt = 0$ and on the border $x = b$, $\int_b^x \partial_y \varphi(t, y) dt = 0$, so that the border integral vanishes. Because of φ 's regularity, we can permutate \int and ∂_y and use once more an Ostrogradsky formula so that

$$\int_{\omega} \partial_y \left(\int_b^x \varphi(t, y) dt \right) h(x, y) dx dy = - \int_{\omega} \left(\int_b^x \varphi(t, y) dt \right) \partial_y h(x, y) dx dy + \int_{\partial\omega} h(x, y) \left(\int_b^x \varphi(t, y) dt \right) \nu_y dl.$$

On the borders $x = a$ and $x = b$, $\nu_y = 0$, on the borders $y = c$ and $y = d$, $\varphi = 0$, so that the border integral vanishes again. We integrate by parts again and obtain

$$- \int_{\omega} \left(\int_b^x \varphi(t, y) dt \right) \partial_y h(x, y) dx dy = \int_{\omega} \left(\int_a^x \partial_y h(t, y) dt \right) \varphi(t, y) dx dy - \int_{\partial\omega} \left(\int_a^x \partial_y h(t, y) dt \right) \left(\int_b^x \varphi(t, y) dt \right) \nu_x dl.$$

Since the border integral is again equal to 0, we have the expected equality in $\mathcal{D}'(\omega)$. To conclude, from **Property 1**, we know that $\int_a^x \partial_y h(t, y) dt$ is in $L^2(\omega)$, so the equality takes place in $L^2(\omega)$. ■

3.1 Hyperbolic shell totally clamped

Let us suppose that the middle surface of the shell is the following portion of a hyperbolic paraboloid

$$\mathcal{HP} := \left\{ (x_1, x_2, x_3) \in \mathbb{R}^3, \frac{x_3}{a_3} = \frac{x_1^2}{a_1^2} - \frac{x_2^2}{a_2^2} \text{ with } -x_0 < x_1 < x_0 \text{ and } -y_0 < x_2 < y_0 \right\}$$

and that the shell is totally clamped. We choose a parametrisation of \mathcal{HP} along the asymptotic lines, so that the mapping θ is

$$\theta : \begin{array}{l} \bar{\omega} \longrightarrow \mathbb{R}^3 \\ (\varphi, \psi) \longmapsto \left(\frac{a_1}{2} (\varphi + \psi), \frac{a_2}{2} (\varphi - \psi), a_3 \varphi \psi \right) \end{array}$$

where ω is the subset

$$\omega := \left\{ (\varphi, \psi) \in \mathbb{R}^2, \varphi - \frac{2y_0}{a_2} < \psi < \varphi + \frac{2y_0}{a_2} \text{ and } -\varphi - \frac{2x_0}{a_1} < \psi < -\varphi + \frac{2x_0}{a_1} \right\}.$$

The border is then represented by

$$\partial\omega := \left\{ \begin{array}{l} \left(\varphi, \varphi - \frac{2y_0}{a_2} \right), \varphi \in \left[-\frac{x_0}{a_1} + \frac{y_0}{a_2}, +\frac{x_0}{a_1} + \frac{y_0}{a_2} \right] \\ \left(\varphi, \varphi + \frac{2y_0}{a_2} \right), \varphi \in \left[-\frac{x_0}{a_1} - \frac{y_0}{a_2}, +\frac{x_0}{a_1} - \frac{y_0}{a_2} \right] \\ \left(\varphi, -\varphi - \frac{2x_0}{a_1} \right), \varphi \in \left[-\frac{x_0}{a_1} - \frac{y_0}{a_2}, -\frac{x_0}{a_1} + \frac{y_0}{a_2} \right] \\ \left(\varphi, -\varphi + \frac{2x_0}{a_1} \right), \varphi \in \left[+\frac{x_0}{a_1} - \frac{y_0}{a_2}, +\frac{x_0}{a_1} + \frac{y_0}{a_2} \right] \end{array} \right\} \cup$$

In these coordinates, the second fundamental form $(b_{\alpha\beta})_{\alpha\beta}$ verifies,

$$b_{11} = b_{22} = 0 \text{ and } b_{12} \neq 0,$$

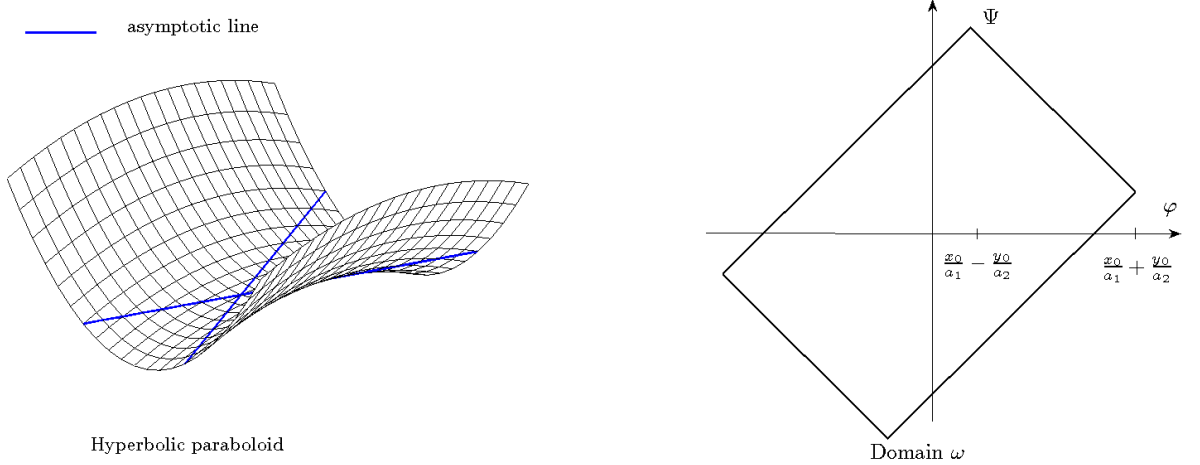

Figure 1: Hyperbolic shell totally clamped

the Christoffel symbols are such that,

$$\Gamma_{11}^1 = \Gamma_{22}^2 = \Gamma_{22}^1 = \Gamma_{11}^2 = 0, \Gamma_{12}^1 \neq 0 \text{ and } \Gamma_{12}^2 \neq 0,$$

and the Jacobian \sqrt{a} is different from 0. The displacement field $\eta = (\eta_i)$ is looked for in $\mathbf{H}_0^1(\omega)$. Under these assumptions, the admissibility condition given by (4) becomes : find $h^{\alpha\beta}$ in $L^2(\omega)$, such that for all $\eta = (\eta_i) \in \mathbf{H}_0^1(\omega)$,

$$\int_{\omega} h^i \eta_i \sqrt{a} dy = \int_{\omega} (h^{11} \partial_{\varphi} \eta_1 + h^{22} \partial_{\psi} \eta_2 + h^{12} (\partial_{\psi} \eta_1 + \partial_{\varphi} \eta_2 - 2\Gamma_{12}^1 \eta_1 - 2\Gamma_{12}^2 \eta_2 - 2b_{12} \eta_3)) \sqrt{a} dy \quad (14)$$

Theorem 4 *The surface force $\mathbf{h} = (h^i) \in \mathbf{L}^2(\omega)$ is admissible if h^3 is in $H^1(\omega)$.*

Proof. Let h^1, h^2 be in $L^2(\omega)$, h^3 be in $H^1(\omega)$. Let

$$V_{\varphi}(\omega) := \{h \in L^2(\omega), \partial_{\varphi} h \in L^2(\omega)\},$$

$$V_{\psi}(\omega) := \{h \in L^2(\omega), \partial_{\psi} h \in L^2(\omega)\}.$$

From **Theorem 3**, we know that \mathbf{h} is admissible if there exist h^{11} in $V_{\varphi}(\omega)$, h^{22} in $V_{\psi}(\omega)$ and h^{12} in $H^1(\omega)$ such that :

$$\begin{cases} -\partial_{\beta}(h^{\alpha\beta} \sqrt{a}) - \Gamma_{12}^{\alpha}(h^{12} \sqrt{a}) = h^{\alpha} \sqrt{a} & \text{for } \alpha = 1, 2 \\ -2b_{12} h^{12} = h^3 \end{cases}$$

$h^{12} = -\frac{h^3}{2b_{12}}$ is appropriate since it is in $H^1(\omega)$. We substitute this function for h^{12} and thus obtain two uncoupled PDE

$$\partial_{\varphi}(h^{11} \sqrt{a}) = \hat{f}_1 \text{ in } L^2(\omega)$$

where

$$\hat{f}_1 := -h^1 \sqrt{a} + \partial_{\psi} \left(\frac{1}{2b_{12}} h^3 \sqrt{a} \right) + \frac{\Gamma_{12}^1}{b_{12}} h^3 \sqrt{a} \in L^2(\omega),$$

and,

$$\partial_\psi (h^{22}\sqrt{a}) = \hat{f}_2 \text{ in } L^2(\omega)$$

where

$$\hat{f}_2 := -h^2\sqrt{a} + \partial_\varphi \left(\frac{1}{2b_{12}} h^3\sqrt{a} \right) + \frac{\Gamma_{12}^2}{b_{12}} h^3\sqrt{a} \in L^2(\omega).$$

For almost all $(\varphi, \psi) \in \omega$, let

$$g(\varphi, \psi) := \frac{1}{\sqrt{a}} \int_0^\varphi \hat{f}_1(\eta, \psi) d\eta,$$

then of course $\partial_\varphi (g\sqrt{a}) = \hat{f}_1$ in $L^2(\omega)$. So, we just need to prove that g is in $L^2(\omega)$ to have g in $V_\varphi(\omega)$ and thereby get the result by letting $h^{11} = g$. From the Cauchy-Schwarz inequality, for almost all $(\varphi, \psi) \in \omega$, we have :

$$\int_0^\varphi \hat{f}_1(\eta, \psi) d\eta \leq \sqrt{\left| \int_0^\varphi \hat{f}_1^2(\eta, \psi) d\eta \right|} \sqrt{\left| \int_0^\varphi 1^2 d\eta \right|}$$

so that

$$\left(\int_0^\varphi \hat{f}_1(\eta, \psi) d\eta \right)^2 \leq |\varphi| \left| \int_0^\varphi \hat{f}_1^2(\eta, \psi) d\eta \right|. \quad (15)$$

Let $\tilde{\omega}$ be the following open subset which contains ω

$$\tilde{\omega} := \left] -\frac{x_0}{a_1} - \frac{y_0}{a_2}, \frac{x_0}{a_1} + \frac{y_0}{a_2} \right[\times \left] -\frac{x_0}{a_1} - \frac{y_0}{a_2}, \frac{x_0}{a_1} + \frac{y_0}{a_2} \right[.$$

and let \tilde{f}_1 be the extension by zeros of \hat{f}_1 to $\tilde{\omega}$. Since \hat{f}_1 is in $L^2(\omega)$ then \tilde{f}_1 is in $L^2(\tilde{\omega})$ too and obviously, if the integrals exist, they verify

$$\int_\omega \left(\int_0^\varphi \hat{f}_1(\eta, \psi) \partial\eta \right)^2 dy \leq \int_{\tilde{\omega}} \left(\int_0^\varphi \tilde{f}_1(\eta, \psi) \partial\eta \right)^2 dy$$

For all $(\varphi, \psi) \in \tilde{\omega}$, $|\varphi| \leq \frac{x_0}{a_1} + \frac{y_0}{a_2}$, so, after integrating (15) on $\tilde{\omega}$, we obtain the following bounding :

$$\int_{\tilde{\omega}} \left(\int_0^\varphi \tilde{f}_1(\eta, \psi) \partial\eta \right)^2 dy \leq \left(\frac{x_0}{a_1} + \frac{y_0}{a_2} \right) \int_{\tilde{\omega}} \left(\int_{-\frac{x_0}{a_1} - \frac{y_0}{a_2}}^{\frac{x_0}{a_1} + \frac{y_0}{a_2}} \tilde{f}_1^2(\eta, \psi) d\eta \right) dy.$$

From the Tonelli Theorem we have :

$$\int_{\tilde{\omega}} \left(\int_{-\frac{x_0}{a_1} - \frac{y_0}{a_2}}^{\frac{x_0}{a_1} + \frac{y_0}{a_2}} \tilde{f}_1^2(\eta, \psi) d\eta \right) dy = \int_{-\frac{x_0}{a_1} - \frac{y_0}{a_2}}^{\frac{x_0}{a_1} + \frac{y_0}{a_2}} \left(\int_{\tilde{\omega}} \tilde{f}_1^2(\eta, \psi) dy \right) d\eta = \left(\frac{x_0}{a_1} + \frac{y_0}{a_2} \right) \|\tilde{f}_1\|_{0, \tilde{\omega}}^2,$$

So, since \tilde{f}_1 is in $L^2(\tilde{\omega})$, we have the expected bounding

$$\int_\omega \left(\int_0^\varphi \hat{f}_1(\eta, \psi) \partial\eta \right)^2 dy < \infty.$$

which insures that g is in $L^2(\omega)$, and, consequently, in $V_\varphi(\omega)$. We proceed the same way to build h^{22} in $V_\psi(\omega)$. ■

3.2 Hyperbolic shell partially clamped

Let us suppose that the middle surface of the shell is a portion of hyperboloid \mathcal{H} and that it is clamped along its entire "lower" face Γ_0 . Let the cartesian equations of \mathcal{H} be

$$\frac{x_1^2}{a_1^2} + \frac{x_2^2}{a_2^2} - \frac{x_3^2}{a_3^2} = 1 \text{ and } z_0 \leq x_3 \leq z_1.$$

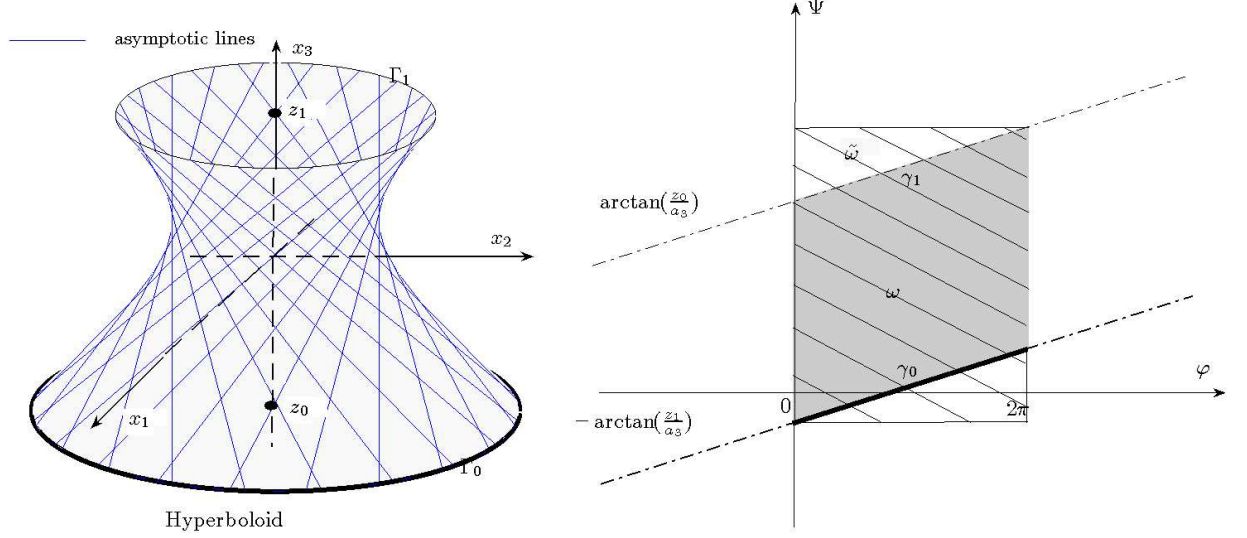

Figure 2: Hyperbolic shell partially clamped

We choose a parametrisation of \mathcal{H} along the asymptotic lines, so that

$$\begin{aligned} \theta : \bar{\omega} &\longrightarrow \mathbb{R}^3 \\ (\varphi, \psi) &\longmapsto \left(a_1 \frac{\cos(\varphi + \psi)}{\cos(\varphi - \psi)}, a_2 \frac{\sin(\varphi + \psi)}{\cos(\varphi - \psi)}, a_3 \tan(\varphi - \psi) \right) \end{aligned}$$

where

$$\begin{aligned} \omega &:= \left\{ (\varphi, \psi), \varphi \in]0, \pi[, \psi \in \left] \varphi - \arctan \frac{z_1}{a_3}, \varphi - \arctan \frac{z_0}{a_3} \right] \right\} \\ &:= \left\{ (\varphi, \psi), \psi \in \left] -\arctan \frac{z_1}{a_3}, \pi - \arctan \frac{z_0}{a_3} \right[, \varphi \in \left[\max \left(\psi + \arctan \frac{z_0}{a_3}, 0 \right), \min \left(\psi + \arctan \frac{z_1}{a_3}, \pi \right) \right] \right\}, \end{aligned}$$

the upper border Γ_1 is represented by

$$\gamma_1 := \left\{ \left(\varphi, \varphi - \arctan \frac{z_1}{a_3} \right), \varphi \in]0, \pi[\right\} := \left\{ \left(\psi + \arctan \frac{z_1}{a_3}, \psi \right), \psi \in \left] -\arctan \frac{z_1}{a_3}, \pi - \arctan \frac{z_0}{a_3} \right[\right\},$$

and where the lower border Γ_0 is represented by

$$\gamma_0 := \left\{ \left(\varphi, \varphi - \arctan \frac{z_0}{a_3} \right), \varphi \in]0, \pi[\right\} := \left\{ \left(\psi + \arctan \frac{z_0}{a_3}, \psi \right), \psi \in \left] -\arctan \frac{z_1}{a_3}, \pi - \arctan \frac{z_0}{a_3} \right[\right\}.$$

Let $\tilde{\omega}$ be the open subset

$$\tilde{\omega} := \left] \arctan \frac{z_0}{a_3} - \arctan \frac{z_1}{a_3}, \pi \right[\times \left] \arctan \frac{z_0}{a_3} - \arctan \frac{z_1}{a_3}, \pi - \arctan \frac{z_0}{a_3} \right[.$$

The displacement field is looked for in $\mathbf{V}(\omega) = \{ \mathbf{v} \in \mathbf{H}^1(\omega), \mathbf{v} \text{ } \pi\text{-periodic, } \mathbf{v} = \mathbf{0} \text{ on } \gamma_0 \}$. The second fundamental form $(b_{\alpha\beta})_{\alpha\beta}$ is π -periodic, such that,

$$b_{11} = b_{22} = 0 \text{ and } b_{12} \neq 0,$$

the Christoffel symbols are π -periodic, such that,

$$\Gamma_{11}^1 = -\Gamma_{22}^2 = 2 \tan(\varphi - \psi), \Gamma_{22}^1 = \Gamma_{11}^2 = 0, \Gamma_{12}^1 \neq 0 \text{ and } \Gamma_{12}^2 \neq 0,$$

and the jacobian \sqrt{a} is π -periodic, different from 0. Under these assumptions, the admissibility condition (4) becomes $h^{\alpha\beta} \in L^2(\omega)$, such that :

$$\int_{\omega} h^i \eta_i \sqrt{a} dy = \int_{\omega} (h^{11} (\partial_{\varphi} \eta_1 - 2 \tan(\varphi - \psi) \eta_1) + h^{22} (\partial_{\psi} \eta_2 + 2 \tan(\varphi - \psi) \eta_2)) \sqrt{a} dy + \int_{\omega} h^{12} (\partial_{\psi} \eta_1 + \partial_{\varphi} \eta_2 - 2\Gamma_{12}^1 \eta_1 - 2\Gamma_{12}^2 \eta_2 - 2b_{12} \eta_3) \sqrt{a} dy \text{ for all } \eta \in \mathbf{V}(\omega). \quad (16)$$

Theorem 5 *The π -periodic surface force $\mathbf{h} = (h^i) \in \mathbf{L}^2(\omega)$ is admissible if*

$$\begin{cases} h^3 \in H^1(\omega), \partial_{\varphi\psi} h^3 \in L^2(\omega), h^3 = 0 \text{ on } \gamma_1 \\ \partial_{\varphi} h^1 \in L^2(\omega), \\ \partial_{\psi} h^2 \in L^2(\omega). \end{cases} \quad (17)$$

Proof. Let $\mathbf{h} = (h^i)$ be a π -periodic function of $\mathbf{L}^2(\omega)$ satisfying (17) and let

$$V_{\varphi}(\omega) := \{h \in L^2(\omega), \partial_{\varphi} h \in L^2(\omega), h \text{ } \pi\text{-periodic and } h\nu_{\varphi} = 0 \text{ on } \gamma_1\},$$

$$V_{\psi}(\omega) := \{h \in L^2(\omega), \partial_{\psi} h \in L^2(\omega), h \text{ } \pi\text{-periodic and } h\nu_{\psi} = 0 \text{ on } \gamma_1\}.$$

From **Theorem 3** we know that \mathbf{h} is admissible if there exist h^{11} in $V_{\varphi}(\omega)$, h^{22} in $V_{\psi}(\omega)$ and h^{12} in $V_{\varphi}(\omega) \cap V_{\psi}(\omega)$ such that :

$$\begin{cases} -\partial_{\varphi}(h^{11}\sqrt{a}) - \partial_{\psi}(h^{12}\sqrt{a}) - \Gamma_{11}^1 h^{11}\sqrt{a} - 2\Gamma_{12}^1 h^{12}\sqrt{a} = h^1\sqrt{a} \\ -\partial_{\varphi}(h^{12}\sqrt{a}) - \partial_{\psi}(h^{22}\sqrt{a}) - \Gamma_{22}^2 h^{22}\sqrt{a} - 2\Gamma_{12}^2 h^{12}\sqrt{a} = h^2\sqrt{a} \\ -2b_{12}h^{12} = h^3 \end{cases}$$

$h^{12} = -\frac{h^3}{2b_{12}}$ is appropriate since it is in $V_{\varphi}(\omega) \cap V_{\psi}(\omega)$. We substitute h^{12} and thus obtain two uncoupled PDE :

$$-\partial_{\varphi}(h^{11}\sqrt{a}) - 2 \tan(\varphi - \psi)(h^{11}\sqrt{a}) = (h^1\sqrt{a}) - \partial_{\psi}\left(\frac{1}{2b_{12}}h^3\sqrt{a}\right) - \frac{\Gamma_{12}^1}{b_{12}}h^3\sqrt{a}$$

and

$$-\partial_{\psi}(h^{22}\sqrt{a}) + 2 \tan(\varphi - \psi)(h^{22}\sqrt{a}) = (h^2\sqrt{a}) - \partial_{\varphi}\left(\frac{1}{2b_{12}}h^3\sqrt{a}\right) - \frac{\Gamma_{12}^2}{b_{12}}h^3\sqrt{a}.$$

Let us notice that

$$\partial_{\varphi}(h^{11}\sqrt{a}) + 2 \tan(\varphi - \psi)(h^{11}\sqrt{a}) = \cos^2(\varphi - \psi) \partial_{\varphi}\left(\frac{h^{11}\sqrt{a}}{\cos^2(\varphi - \psi)}\right),$$

and that

$$\partial_{\psi}(h^{22}\sqrt{a}) - 2 \tan(\varphi - \psi)(h^{22}\sqrt{a}) = \cos^2(\varphi - \psi) \partial_{\psi}\left(\frac{h^{22}\sqrt{a}}{\cos^2(\varphi - \psi)}\right),$$

so if we let

$$\hat{f}_1 := \frac{1}{\cos^2(\varphi - \psi)} \left(-(h^1\sqrt{a}) + \partial_{\psi}\left(\frac{1}{2b_{12}}(h^3\sqrt{a})\right) + \frac{\Gamma_{12}^1}{b_{12}}(h^3\sqrt{a}) \right)$$

and

$$\hat{f}_2 := \frac{1}{\cos^2(\varphi - \psi)} \left(-(h^2\sqrt{a}) + \partial_{\varphi}\left(\frac{1}{2b_{12}}(h^3\sqrt{a})\right) + \frac{\Gamma_{12}^2}{b_{12}}(h^3\sqrt{a}) \right).$$

\hat{f}_1 and \hat{f}_2 are both π -periodic and, because of (17), both in $L^2(\omega)$. Therefore, \mathbf{h} is admissible if we can find $h^{11} \in V_{\varphi}(\omega)$ such that

$$\partial_{\varphi}\left(\frac{h^{11}\sqrt{a}}{\cos^2(\varphi - \psi)}\right) = \hat{f}_1 \text{ in } L^2(\omega)$$

and $h^{22} \in V_\psi(\omega)$ such that

$$\partial_\psi \left(\frac{h^{22} \sqrt{a}}{\cos^2(\varphi - \psi)} \right) = \hat{f}_2 \text{ in } L^2(\omega).$$

Let \tilde{f}_1 be the extension by zeros of \hat{f}_1 to $\tilde{\omega}$. Since \hat{f}_1 is in $L^2(\omega)$ then \tilde{f}_1 is in $L^2(\tilde{\omega})$. For almost all $(\varphi, \psi) \in \omega$, let

$$g(\varphi, \psi) := \frac{\cos^2(\varphi - \psi)}{\sqrt{a}} \int_{\psi + \arctan \frac{z_0}{a_3}}^\varphi \hat{f}_1(\eta, \psi) d\eta,$$

and let us prove that g is in $V_\varphi(\omega)$. In order to do that, we just have to prove that the integral $\int_{\psi + \arctan \frac{z_0}{a_3}}^\varphi \hat{f}_1(\eta, \psi) d\eta$ is in $L^2(\omega)$ and vanishes on γ_1 . The second point is obvious. From the Cauchy-Schwarz inequality, for almost all $(\varphi, \psi) \in \omega$, we have :

$$\left(\int_{\psi + \arctan \frac{z_0}{a_3}}^\varphi \hat{f}_1(\eta, \psi) d\eta \right)^2 \leq \left| \int_{\psi + \arctan \frac{z_0}{a_3}}^\varphi \hat{f}_1^2(\eta, \psi) d\eta \int_{\psi + \arctan \frac{z_0}{a_3}}^\varphi 1^2 d\eta \right|.$$

Since for all $(\varphi, \psi) \in \omega$, $\left| \varphi - \psi - \arctan \frac{z_0}{a_3} \right| \leq \pi$ and since \hat{f}_1 is π -periodic then,

$$\left(\int_{\psi + \arctan \frac{z_0}{a_3}}^\varphi \hat{f}_1(\eta, \psi) d\eta \right)^2 \leq \pi \int_0^\pi \hat{f}_1^2(\eta, \psi) d\eta$$

moreover, as $\omega \subset \tilde{\omega}$, we have the following bounding :

$$\int_\omega \left(\int_{\psi + \arctan \frac{z_0}{a_3}}^\varphi \hat{f}_1(\eta, \psi) d\eta \right)^2 dy \leq \pi \int_{\tilde{\omega}} \left(\int_0^\pi \hat{f}_1^2(\eta, \psi) d\eta \right) dy.$$

We conclude with the Tonelli Theorem that :

$$\pi \int_{\tilde{\omega}} \left(\int_0^\pi \hat{f}_1^2(\eta, \psi) d\eta \right) dy = \pi^2 \|\tilde{f}_1\|_{0, \tilde{\omega}}^2 < \infty,$$

so, $h^{11} = g$ is a suitable solution. We proceed the same way to find h^{22} in $V_\psi(\omega)$. ■

3.3 Parabolic shell totally clamped

Let us suppose the shell \mathcal{C} is a portion of a cone which is subjected to a boundary condition of place along its whole lateral face.

$$\mathcal{C} := \{(x_1, x_2, x_3) \in \mathbb{R}^3, x_1 = r \cos \theta, x_2 = r \sin \theta, x_3 = r \cot \varphi, (r, \theta) \in \tilde{\omega}\}$$

where

$$\omega :=]r_0, r_1[\times]\theta_0, \theta_1[\text{ and } \varphi \in]0, \pi/2[.$$

The admissibility condition (4) becomes : find $h^{\alpha\beta}$ in $L^2(\omega)$, such that for all $\eta = (\eta_i) \in \mathbf{H}_0^1(\omega)$,

$$\int_\omega h^i \eta_i \sqrt{a} dy = \int_\omega \left(h^{11} \partial_r \eta_1 + h^{22} (\partial_\theta \eta_2 + r \sin^2 \varphi \eta_2 - r \cos \varphi \eta_3) + h^{12} \left(\partial_\theta \eta_1 + \partial_r \eta_2 - \frac{2}{r} \eta_2 \right) \right) \sqrt{a} dy \quad (18)$$

where $\sqrt{a} = \frac{r}{\sin \varphi}$.

Theorem 6 *The surface force $\mathbf{h} = (h^i) \in \mathbf{L}^2(\omega)$ is admissible as soon as*

$$\partial_\theta h^2, \partial_\theta h^3 \text{ and } \partial_{\theta\theta} h^3 \text{ are in } L^2(\omega). \quad (19)$$

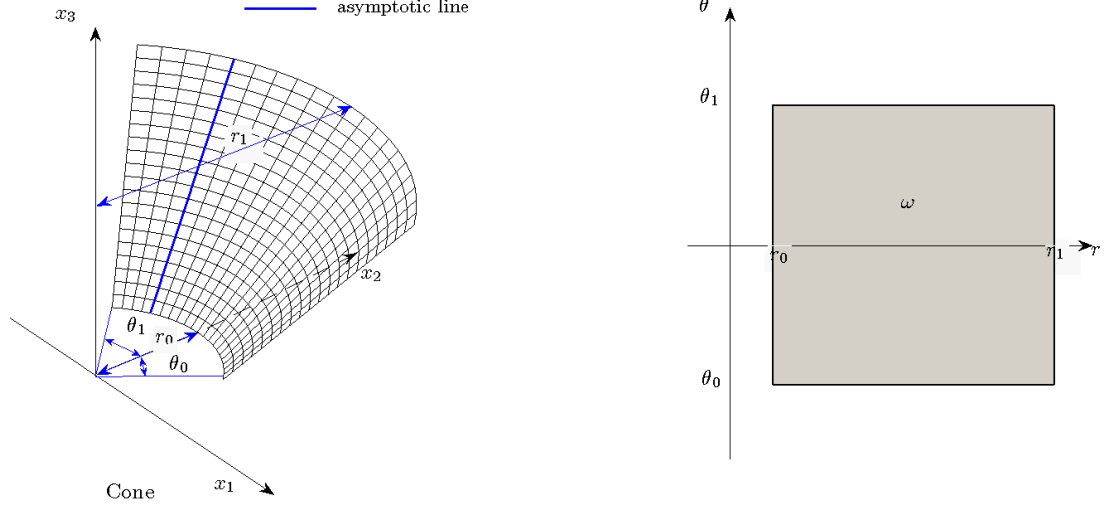

Figure 3: Parabolic shell totally clamped

Proof. Let $\mathbf{h} = (h^i)$ be a function of $\mathbf{L}^2(\omega)$ satisfying (19). If we can find h^{11}, h^{22} in $L^2(\omega)$ such that $\partial_r h^{11}$ and $\partial_\theta h^{22}$ are in $L^2(\omega)$, and h^{12} in $H^1(\omega)$ satisfying

$$\begin{cases} -\partial_r(h^{11}\sqrt{a}) - \partial_\theta(h^{12}\sqrt{a}) + r \sin^2 \varphi h^{12}\sqrt{a} = h^1\sqrt{a} \\ -\partial_r(h^{12}\sqrt{a}) - \partial_\theta(h^{22}\sqrt{a}) - \frac{2}{r}h^{12}\sqrt{a} = h^2\sqrt{a} \\ -r \cos \varphi h^{22} = h^3 \end{cases} \quad (20)$$

then \mathbf{h} is admissible. Let $h^{22} = -\frac{h^3}{r \cos \varphi}$, both h^{22} and $\partial_\theta h^{22}$ are in $L^2(\omega)$. Let us point out that $\partial_r \eta - \frac{2}{r}\eta = r^2 \partial_r(\frac{\eta}{r^2})$ and substitute h^{22} in (20), then, h^{12} satisfies

$$-\partial_r(r^3 h^{12}) = h^2 r^3 - \frac{r^2}{\cos \varphi} \partial_\theta h^3 \text{ in } L^2(\omega),$$

A possibility for h^{12} is

$$h^{12} = \frac{1}{r^3} \int_{r_0}^r \left(-h^2 r^3 + \frac{r^2}{\cos \varphi} \partial_\theta h^3 \right) dr.$$

With this choice, $h^{12}, \partial_r h^{12}$ and $\partial_\theta h^{12}$ are in $L^2(\omega)$ as shown by **Property 1** and **Property 2**. Finally, replacing h^{12} and h^{22} in (20) and integrating by parts, we notice that if there exists $h^{11} \in L^2(\omega)$ such that

$$-\partial_r(r h^{11}) = r h^1 + \frac{1}{r^2} \int_{r_0}^r \partial_\theta \left(-h^2 r^3 + \frac{r^2}{\cos \varphi} \partial_\theta h^3 \right) dr + r \frac{\sin^2 \varphi}{\cos \varphi} h^3 \text{ in } L^2(\omega),$$

the admissibility conditions are fulfilled. So, we just have to let

$$h^{11} = -\frac{1}{r} \int_{r_0}^r \left(r h^1 + \frac{1}{r^2} \int_{r_0}^r \partial_\theta \left(-h^2 r^3 + \frac{r^2}{\cos \varphi} \partial_\theta h^3 \right) dr + r \frac{\sin^2 \varphi}{\cos \varphi} h^3 \right) dr.$$

to conclude. ■

Remark 2 If we suppose that the shell is subjected to a boundary condition of place along a portion its lateral face, for example on $r = r_1$ we have to add the following border conditions to \mathbf{h} :

$$h^2_{|\theta=\theta_0} = h^2_{|\theta=\theta_1} = h^3_{|\theta=\theta_0} = h^3_{|\theta=\theta_1} = \partial_\theta h^3_{|\theta=\theta_0} = \partial_\theta h^3_{|\theta=\theta_1} = 0.$$

These equations are obtained by canceling the border integrals during the integration by parts.

3.4 Parabolic shell partially clamped

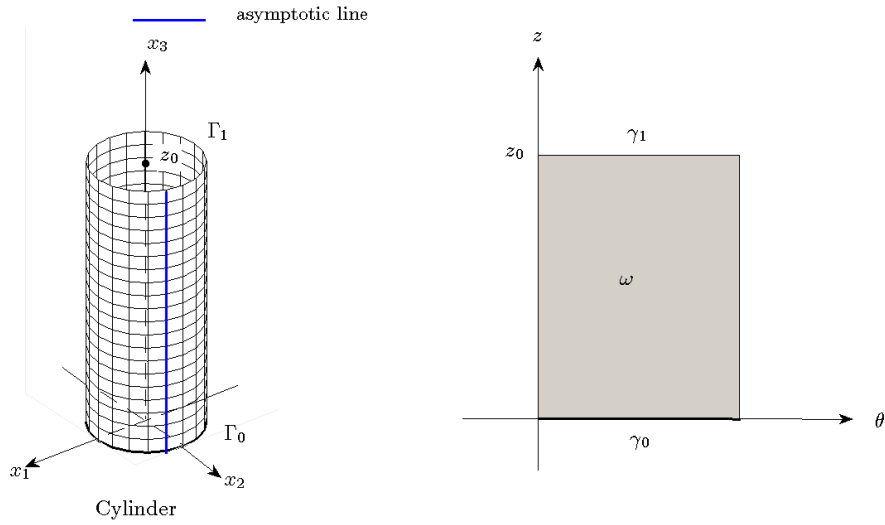

Figure 4: Parabolic shell partially clamped

Let us suppose that the middle surface of the shell is a portion of cylinder \mathcal{C}

$$\mathcal{C} := \{(x_1, x_2, x_3) \in \mathbb{R}^3, x_1 = \cos \theta, x_2 = \sin \theta, x_3 = z \text{ for } (\theta, z) \in \bar{\omega}\}$$

where

$$\omega :=]0, 2\pi[\times]0, z_0[\text{ and } z_0 > 0,$$

and that the shell is subjected to a boundary condition of place along its entire "lower" face

$$\Gamma_0 := \{(x_1, x_2, x_3) \in \mathbb{R}^3, x_1 = \cos \theta, x_2 = \sin \theta, x_3 = 0 \text{ for } \theta \in [0, 2\pi[\}.$$

In these coordinates, the second fundamental form $(b_{\alpha\beta})_{\alpha,\beta}$ is

$$b_{11} = -1, b_{12} = 0 \text{ and } b_{22} = 0,$$

all the Christoffel symbols are equal to 0 whereas the jacobian \sqrt{a} is equal to 1. Let $\gamma_0 := \{(\theta, 0) \text{ for } \theta \in]0, 2\pi[\}$ and $\gamma_1 := \{(\theta, z_0) \text{ for } \theta \in]0, 2\pi[\}$. The displacement field is looked for in

$$\mathbf{V}(\omega) := \{\mathbf{v} \in \mathbf{H}^1(\omega), \mathbf{v} \text{ } 2\pi\text{-periodic with respect to the first variable, } \mathbf{v} = \mathbf{0} \text{ on } \gamma_0 \}.$$

The admissibility condition (4) becomes : find $h^{\alpha\beta} \in L^2(\omega)$ such that for all $\eta = (\eta_i) \in \mathbf{V}(\omega)$

$$\int_{\omega} h^i \eta_i dy = \int_{\omega} (h^{11} (\partial_\theta \eta_1 + \eta_3) + h^{12} (\partial_z \eta_1 + \partial_\theta \eta_2) + h^{22} \partial_z \eta_2) dy \quad (21)$$

Theorem 7 *The surface force $\mathbf{h} = (h^i) \in \mathbf{L}^2(\omega)$, 2π -periodic with respect to the first variable, is admissible if*

$$\partial_\theta h^1, \partial_\theta h^3 \text{ and } \partial_{\theta\theta} h^3 \text{ are in } L^2(\omega). \quad (22)$$

Proof. Let η be in $V(\omega)$ and let $\mathbf{h} = (h^i)$ be a 2π -periodic with respect to the first variable function of $\mathbf{L}^2(\omega)$ satisfying (22). Taking successively as test function $\eta = (\eta, 0, 0)$, $(0, \eta, 0)$ and $(0, 0, \eta)$ in (21) we obtain the three following equations satisfied by all $\eta \in V(\omega)$:

$$\begin{aligned} \int_\omega h^1 \eta dy &= \int_\omega (h^{11} \partial_\theta \eta + h^{12} \partial_z \eta) dy \\ \int_\omega h^2 \eta dy &= \int_\omega (h^{12} \partial_\theta \eta + h^{22} \partial_z \eta) dy \\ \int_\omega h^3 \eta dy &= \int_\omega h^{11} \eta dy \end{aligned}$$

These equations are satisfied by

$$h^{11} = h^3, \quad h^{12} = \int_z^{z_0} (h^1 + \partial_\theta h^3) dz \text{ and } h^{22} = \int_z^{z_0} \left(h^2 + \int_z^{z_0} \partial_\theta (h^1 + \partial_\theta h^3) dz \right) dz.$$

■

4 Conclusion

The method developed to obtain, from **Theorem 2** and **Theorem 3**, sufficient admissibility conditions gives rather simple results (conditions of regularity and behaviour on the border). The difficulty to get these conditions depends on the geometry of the shell and on its clamping. For example, for elliptic partially clamped shells, it doesn't work. Nevertheless, **Theorem 2** can be the start of other methods which lead to different sufficient admissibility conditions. One of them is developed in one example in Poutous [6].

References

- [1] D. Chapelle and K. J. Bathe, *The Finite Element Analysis of Shells Fundamentals*, Computational Fluid and Solid Mechanics (Springer-Verlag Berlin Heidelberg, 2003).
- [2] P. G. Ciarlet, *Mathematical Elasticity, Vol. III. Theory of Shells*, Studies in Mathematics and Its Applications, Vol. 29 (North-Holland Publishing Co., Amsterdam, 2000).
- [3] P. G. Ciarlet and V. Lods, Asymptotic analysis of linearly elastic shells: "Generalized membrane shells", *J. Elasticity* **43**(2) (1996) 147-188.
- [4] V. Lods and C. Mardare, Justification des modèles linéaires de Koiter et de Naghdi pour des coques totalement encastrées soumises des forces "non admissibles", *C. R. Acad. Sci. Paris, Ser I* **333** (2001) 151-154.
- [5] R. Luce, C. Poutous and J.-M. Thomas, Weakened conditions of admissibility of surface forces applied to linearly elastic membrane shells, *C. R. Acad. Sci. Paris, Ser I* **334** (2007) 721-726 .
- [6] C. Poutous, Modélisation asymptotique et analyse numérique d'un problème de couplage fluide-structure, Thèse de doctorat, Université de Pau et des Pays de l'Adour, (2006).
- [7] J. Sanchez-Hubert and E. Sanchez-Palencia, *Coques élastiques minces. Propriétés asymptotiques*, (Masson, Paris, 1997).

- [8] E. Sanchez-Palencia, On the membrane approximation for thin elastic shells in the hyperbolic case, *Revista Matematica de la Universidad Complutense de Madrid* **6**(2) (1993) 311-331 .
- [9] S. Slicaru, On the ellipticity of the middle surface of a shell and its application to the asymptotic analysis of "membrane shells", *J. Elasticity* **46**(1) (1997) 33-42 .