



Synchronous design of avionic applications based on model refinements

Abdoulaye Gamatié, Thierry Gautier, Paul Le Guernic

► To cite this version:

Abdoulaye Gamatié, Thierry Gautier, Paul Le Guernic. Synchronous design of avionic applications based on model refinements. Journal of Embedded Computing (IOS Press), IOS Press, 2006, 2 (3-4), pp.273-289. hal-00541523

HAL Id: hal-00541523

<https://hal.archives-ouvertes.fr/hal-00541523>

Submitted on 30 Nov 2010

HAL is a multi-disciplinary open access archive for the deposit and dissemination of scientific research documents, whether they are published or not. The documents may come from teaching and research institutions in France or abroad, or from public or private research centers.

L'archive ouverte pluridisciplinaire **HAL**, est destinée au dépôt et à la diffusion de documents scientifiques de niveau recherche, publiés ou non, émanant des établissements d'enseignement et de recherche français ou étrangers, des laboratoires publics ou privés.

Synchronous Design of Avionic Applications based on Model Refinement

Abdoulaye Gamatié*[†], Thierry Gautier[‡] and Paul Le Guernic[§]

Abstract

In this article, we address the design of avionic applications based on an approach, which relies on model refinement. This study is done within the synchronous framework, which has solid mathematical foundations enabling formal methods for specification, verification and analysis, transformations, etc. In the proposed approach, we first consider a functional description of a given application using the SIGNAL language. This description is independent of a specific implementation platform. Then, some transformations that fully preserve the semantics of manipulated SIGNAL programs are applied to the description such that a representation reflecting an *integrated modular avionics* architecture results.

Keywords: Integrated Modular Avionics, ARINC, synchronous design, SIGNAL, model refinement.

*Corresponding author. Phone: +33 3 59 57 78 16; Fax: +33 3 28 77 85 38; E-mail: Abdoulaye.Gamatie@lifl.fr

[†]INRIA FUTURS, Synergie Park, 6bis avenue Pierre et Marie Curie, 59260 Lezennes

[‡]IRISA, Campus de Beaulieu, 35042 Rennes, France. Email: Thierry.Gautier@irisa.fr

[§]IRISA, Campus de Beaulieu, 35042 Rennes, France. Email: Paul.LeGuernic@irisa.fr

1 Introduction

Avionics play an important role in the overall cost of modern aircrafts (e.g., in civil aeronautics, it is estimated around 35% of the global cost). By avionics, we mean electronic systems, equipment, and other devices aboard aircrafts, which achieve functions like the treatment of information received from sensors, the autopilot, the management of fuel level, communication with an operator during a flight, etc. Today, we notice that avionics have significantly evolved. In particular, the following observations can be made about modern avionics [31] [34] [15]:

- functionalities are increasing in these systems: maintenance and on-board diagnostic, mission simulation, need of autonomy, etc. On the other hand, the integration level of functions is getting higher for an efficient cooperation;
- contrarily to the traditional approach where functions are loosely coupled (e.g., the autopilot and navigation functions are achieved by applications using different computing resources), avionics progressively adopt an integrated approach, where functions (even of different criticality levels) can be achieved through applications that share common computing resources;
- the industry of avionics tends to use more and more commercial material components, which are not *a priori* designed for these systems. While this could help to reduce the development cost and increase functionalities, there is the risk of guarantee lack of such products (as

a matter of fact, they rapidly become obsolete or unavailable);

- the correctness and reliability requirements call for the use of formal methods in order to efficiently cope with validation problems.

Therefore, the increasing complexity and high criticality of embedded real-time systems in the avionic domain raise some challenging issues about their development. Among these issues, we mention the correctness of designed systems against requirements, development effort, correctness and reliability of implementations (e.g. the costs of minor and major bugs respectively range from \$100K to \$500K and from \$1M to \$500M), time-to-market (which is between three and four years). Therefore, there is the need of suitable methodologies that efficiently address above issues. According to Pnueli [32], such methodologies must enable at least formal specifications, verification and analysis, and automatic (possibly distributed) code generation.

In this article, we address the design of avionic applications based on model refinement within the development environment POLYCHRONY, associated with the synchronous language SIGNAL. Synchronous technologies are interesting because of their formal basis, which favors validation. The remainder of the article is organized as follows: Section 2 first introduces avionics architectures: *federated architectures* and *integrated modular avionics* - IMA (our study relies on the latter); then, Section 3 presents related work; after a short introduction to the SIGNAL language in Section 4, we expose our approach to describe IMA applications using the SIGNAL language in Section 5 and 6; finally, concluding remarks are given in Section 7.

2 Architecture design for avionics

We present the two basic approaches for architecture design in the avionic domain: the *federated* approach (Section 2.1) and the *integrated modular* approach (Section 2.2).

2.1 Federated architectures

Traditionally in avionics, each control function is associated with its own material resources (e.g. computer system). These resources are most often replicated for fault tolerance and they vary from one function to another. Hence, it results a loosely-coupled and heterogeneous architecture where every function can be almost executed independently of other functions. It is not the case locally to a function, where concerned components strongly cooperate in order to achieve the mission affected to that function. Such an architecture of avionics is called *federated architecture* [3]. For instance, the *Airbus* A330 and A340 adopt this kind of architecture. The numeric equipments that implement the concerned on-board functions are linked by a mono-emitter bus.

Besides their simplicity, a great advantage of federated architectures is the minimization of the risk for error propagation, which can occur during the execution of a function in the system. Another advantage of these architectures is their inherent heterogeneity (computing resources required by one function may differ from those needed by another). As a result, this enables to use computer systems with variable performance characteristics depending on functions.

However, a major drawback of federated architectures lies in the high risk of massive usage of computing resources (replicated for fault tolerance) since each function requires its dedicated computer system. Consequently, the overall design costs get increased: enough space is required on-board aircrafts in order to support the computing resources (typically, their associated weight), one must cope with the resulting install and maintenance issues, etc.

2.2 Integrated modular avionics (IMA)

More recently, another vision emerged concerning avionics design. This vision aims at dealing with the major obstacles inherent to federated architectures by proposing a system organization where several functions (even of different criticality level) can share now computing and communication resources. This new architecture is referred to as *integrated modular avionics* (IMA) [3]. The *Airbus A380* and *Boeing B777* are examples of aircrafts that adopt this kind of architecture.

IMA enables resource savings, thus reasonably limits the global development costs. However, it may introduce a high error propagation probability, which no longer exists in federated architectures (e.g., an abnormal executing application that achieves some function in the system may monopolize the communication system or may provoke inappropriate commands; it is not easy to preserve each function from such an erroneous behavior). The solution that has been proposed in order to solve this problem consists in a functional decomposition of the system, which takes into account the available memory space and time budget. The logical allocation unit resulting

from the decomposition is called a *partition* [3]. In practice, the *spatial partitioning* of systems relies on the use of material components in charge of memory management, in order to prevent every memory area from corruption during modifications of its neighbored areas. The *temporal partitioning* rather depends on expected system functionalities (e.g., it is crucial to execute regularly the function achieving the refreshment of critical parameters such as the fuel level). Finally, we can notice that partitioning facilitates the verification, validation and certification of avionics.

High-level IMA infrastructures. IMA platforms consist of *core processing modules* (CPM) grouped in *cabinets* throughout the aircraft. Message exchanges between cabinets is achieved through multiplex networks, which are composed of buses (e.g. of ARINC 629 type [1]) or Ethernet strands linked by commutators. The IMA communication networks interacts with its external environment (e.g. sensors and actuators) via gateway modules (GWMs). Fig. 1 and 2 respectively illustrate two kinds of IMA infrastructures [9]. The first one shows an architecture for the Boeing B777 (CPMs exchange messages within cabinets via ARINC 659 buses [2]) while the second one depicts an architecture for the Airbus 380 (here, CPMs communicate via an Ethernet network switched at nodes SW).

Module level. A core processing module contains one or more partitions that possibly belong to functions of different criticality levels. Mechanisms are provided in order to prevent a partition from having “abnormal” access to the memory area of another partition. A processor is allocated to each par-

tition for a fixed time window within a major time frame maintained by the *module-level operating system* (OS). A partition cannot be distributed over multiple processors either in the same module or in different modules. Finally, partitions communicate asynchronously via logical *ports* and *channels*. Message exchanges rely on two transfer modes: *sampling* mode and *queuing* mode. In the former, no message queue is allowed. A message remains in the source port until it is transmitted via the channel or it is overwritten by a new occurrence of the message. A received message remains in the destination port until it is overwritten. A refresh period attribute is associated with each sampling port. When reading a port, a *validity* parameter indicates whether the age of the read message is consistent with the required refresh period attribute of the port. In the queuing mode, ports are allowed to store messages from a source partition in queues until they are received by the destination partition (the queuing discipline is First-In First-Out).

Partition level. Partitions are composed of *processes* that represent executive units (in fact, an IMA partition/process is akin a UNIX process/task). Processes run concurrently and achieve the functions associated with their containing partitions. Each process is uniquely characterized by information (typically, its period, priority or deadline time) useful to the *partition-level OS*, which is responsible for the correct execution of processes within a partition. The scheduling policy for processes is priority preemptive. Communications between processes are achieved by three basic mechanisms. The bounded *buffer* allows to send and receive messages following a FIFO policy. The *event* permits the application to notify processes of the occurrence of

a condition for which they may be waiting. The *blackboard* is used to display and read messages: no message queues are allowed, and any message written on a blackboard remains there until the message is either cleared or overwritten by a new instance of the message. Synchronizations are achieved using a *semaphore*.

The APEX-ARINC 653 standard [4] that codifies the “time/space partitioning” concept of IMA is now adopted by various real-time operating systems, both proprietary and off-the-shelf (e.g. *VxWorks AE653*). It defines an interface allowing IMA applications to access the underlying OS functionalities. This interface includes services for communication between partitions on the one hand and between processes on the other hand, synchronization services for processes, and partition and process management services, etc.

3 Related work

We first give a quick overview of works that specifically focus on IMA design. Then, we present three approaches aiming to address more general issues on avionic software development: AADL (Avionic Architecture Description Language), COTRE (Real Time Components) and SCADE (Safety Critical Application Development Environment). All these approaches promote model-based and formal techniques. In particular, SCADE relies on the synchronous approach, which is also adopted in our study.

A few studies on IMA. We first mention studies that concern the two-

level hierarchical scheduling aspects of IMA systems. In [30] Lee *et al.* present algorithms that provide cyclic partition and channel schedules for IMA systems. In the same context, Audsley and Wellings analyze response times of IMA applications [7]. They point out the possibility of large amount of jitter and discuss possible ways to reduce the jitter by checking process periods with respect to partitions periods. In [23], we illustrate a SIGNAL-based technique for temporal analysis that provides information about the execution time of partitions. Typically, this information is useful when taking decisions about processor allocation to partitions. Another benefit of defining such a technique in a formal framework is the availability of techniques and tools that help to address critical issues such as partitioning of IMA, which still remains to be thoroughly explored. One outstanding study about partitioning has been done by Di Vito [17]. He proposes a formal description of partitioning requirements using the language associated with PVS (Prototype Verification System). However, this description only concerns space partitioning and does not address time partitioning. Communication is another important topic in IMA systems. For this, we merely mention a communication network designed for the Airbus A380 presented by Sánchez-Puebla and Carretero in [35]. Finally, a study addressing certification issues is done by Conmy and McDermid [16] in which they propose a high level failure analysis for IMA that is part of an overall IMA certification strategy.

AADL. The *Avionics Architecture Description Language* is a standard developed by the international Society of Automotive Engineers (SAE) [19]. It is dedicated to the design of the software and hardware components of

avionics and interfaces between these components. The definition of AADL is based on METAH, an Architecture Description Language (ADL) developed by Honeywell [36]. AADL permits the description of the structure of an embedded system as an assembly of software and hardware components in a similar way as in METAH. It also includes a dedicated UML profile. This enables the access to its underlying analysis and code generation tools from UML graphical specifications. While AADL combines various formalisms and tools for the design of embedded real-time systems, our approach relies on the single semantic model of the SIGNAL language. This favors a uniform framework, which facilitates system validation.

COTRE. The COTRE approach [13] is also devoted to the design of embedded real-time systems in the avionic domain. Its main objective consists in providing the designer with a methodology, an ADL called *Cotre* and an environment to describe, verify and implement embedded real-time systems. The *Cotre* language distinguishes two different views for descriptions: a user view expressed using the *Cotre for User* language (termed *U-Cotre*) and a view for verification (termed *V-Cotre*). In fact, the latter plays the role of an intermediate language between U-Cotre and existing verification formalisms (e.g. timed automata, timed Petri nets). Authors of [13] argue that the use of formal techniques is one of the main differences between the Cotre language and other ADLs. COTRE is closely related to AADL.

SCADE. SCADE proposes one of the most popular formal design environments in avionics domain [18] [14]. It supports *correct by construction*

methodology [5] and automated generation of implementation from a high-level formal model of embedded applications (cf. Fig. 3). As a result, drastic savings of the development and validation effort are enabled.

Basically, SCADE provides developer with two kinds of formalism for specification: *graphical block diagrams* - GBDs (familiar to control engineers) and hierarchical *safe state machines* - SSMs (based on the ESTEREL language [12] and the SYNCCHARTS state machine [6]). The former is used for continuous control while the latter is used for discrete control. In this context, *continuous control* means sampling sensors at regular time intervals, performing signal-processing computations on their values, and producing values often using complex mathematical formulas. *Discrete control* means modifying behavior according to events coming either from discrete sensors and user inputs or from internal program events. GBDs and SSMs can be combined in order to define descriptions including both continuous and discrete aspects. SCADE adopts the synchronous computation model [10], which is a fully precise representation of the well-known cycle-based computation model. Roughly speaking, the cycle-based computation model consists of a loop where a program (or a system) repeatedly achieves the following actions: first read inputs from the environment, then compute them, and finally write corresponding outputs (which the environment is waiting for). In particular, SCADE is based on the LUSTRE [26] and ESTEREL languages. Its associated compilers and verifiers can be used to check the consistency of specifications (e.g. detection of missing definitions, coherence of production/consumption rates of data), and to validate them with respect to system requirements. Finally, documentation and embeddable code can be automat-

ically generated from specifications-level descriptions by the SCADE qualifiable code generator (level A with respect to DO-178B guidelines). This is a major advantage of SCADE compared to other synchronous design tools. Among important avionic projects in which the SCADE suite has been used, we can mention the Airbus A380 and Eurocopter.

4 An introduction to the SIGNAL language

The underlying theory of the synchronous approach is that of discrete event systems and automata theory. Time is *logical*: it is handled according to partial order and simultaneity of observed events. Actual execution durations are considered as constraints to be checked during implementation phase. Typical synchronous languages are ESTEREL [12], LUSTRE [26] and SIGNAL [11]. They mainly differ from each other by their programming style (ESTEREL is imperative while LUSTRE and SIGNAL are dataflow oriented). However, joint efforts have been made to provide a common format [8] in order to facilitate interoperability.

SIGNAL [11] is a dataflow oriented language. It handles infinite sequences of typed values that are implicitly indexed by discrete logical time and called *signals*. At a given logical instant, a signal may be present (then it holds a value of some type, e.g., boolean, integer, real, etc.) or absent. There is a particular type of signal called **event**. A signal of this type always carries the value **true**. The set of instants where a signal is present is called its *clock*. Signals that have the same clock are said to be *synchronous*. A SIGNAL *program* also termed a “*process*” (see Fig. 4), is a system of equations

over signals.

SIGNAL relies on a handful of primitive constructs which are combined using a composition operator noted “|”. These core constructs are sufficiently expressive to derive other constructs for comfort and structuring. In the next, we only mention operators used in the next sections:

- **Under-sampling** $y := x \text{ when } b$; signal y takes the value of x when boolean b is *true*. The statements $x := \text{when } b$ and $x := b \text{ when } b$ are equivalent.
- **Deterministic merging** $y := u \text{ default } v$; signal y takes the value of u when u is present; otherwise y takes the value of v .
- **Clock extraction** $c := \hat{x}$; signal c (of type `event`) carries the value *true* whenever x is present.
- **Synchronization**: $x_1 \hat{=} \dots \hat{=} x_n$; signals x_1, \dots, x_n have the same clock.

For more information on SIGNAL, we invite the reader to see [28], which gives a detailed formal presentation of basic concepts of the language.

5 Synchronous modeling of IMA concepts

This section first exposes the design of the basic concepts (introduced in Section 2.2), also referred to as the *building blocks* required for the description of IMA applications in the synchronous multi-clock (or *polychronous*) semantic model [28] of the SIGNAL language (Section 5.1). Then, it gives

a brief presentation of an ongoing work (see Section 5.2) that consists in defining a *modeling paradigm* based on the resulting library of components within a *Generic Modeling Environment* (GME) [29]. The intent is to facilitate the access to the library together with the polychronous development platform through very general modeling environments like GME.

5.1 Basic building blocks

The synchronous design of avionic applications using SIGNAL relies on a few basic blocks [22], which allow us to model partitions: APEX-ARINC 653 services, an RTOS and executive entities (i.e. processes). In the following, we show for each building block, how its corresponding SIGNAL model is obtained.

Modeling of APEX services. To illustrate the approach that has been adopted here, let us consider a typical APEX service: the *read_blackboard* service [4]. It enables messages to be displayed and read in a blackboard. The inputs are the blackboard *identifier* and a *time-out* duration that limits the waiting time on a request, when the blackboard is empty. The outputs are a *message* defined by its address and size, and a *return code* for the diagnostics of the service request. An informal specification of the service is given in [22].

We start by defining an abstract formal description that corresponds to the service (see Fig. 4). This description expresses properties such as logical instants at which a return code is produced (**s.2**). The variable **C_return_code** is a local boolean signal with the value *true* whenever a

return code is received on a read request, i.e. `C_return_code` represents the clock of the return code¹ signal. For the moment, `C_return_code` appears in the description as a local signal. It is defined during refinements of the abstract description. At this stage, we assume that there only exist signals such that properties in which it is involved are satisfied. Property (s.1) states that `C_return_code` and all inputs are synchronous i.e. whenever there is read request, `C_return_code` indicates whether or not a return code is to be produced. Property (s.3) says that messages are received on a read request only when the return code value is `NO_ERROR`.

Lines (d.1) and (d.2) are dependency relations between inputs and outputs. In `SIGNAL`, the notation `x --> y` expresses a dependency relation between two signals `x` and `y` within a logical instant (read: `y` is preceded by `x`). For instance, (d.2) states that `message` and `length` are preceded by `timeout` and `board_ID`, at the logical instants where the return code carries the value `NO_ERROR`.

Descriptions such as the one in Fig. 4 are expressive enough to check, for instance, the conformance of a component model during its integration into a system described within the same formalism. Here, the description exhibits the interface properties of the *read_blackboard* service. More specifically, it states conditions that describe when a message is received by a process on a read request. However, the description does not mention **how** messages can

¹The retrieval of a return code is not always immediate when calling the *read_blackboard* service. Typically, when the blackboard is empty and the `timeout` parameter carries some positive value, the calling process is suspended. In this case, `C_return_code` carries the value *false*. The suspended process must wait: either a message is displayed on the blackboard, or the expiration of the activated time counter, which produces the return code `TIMED_OUT`.

be obtained.

The specifications given in [4] are somewhat imprecise. This gives rise to ambiguities, which are not easy to see. As an example we can think of two possible implementations for the *read_blackboard* service. They mainly depend on the interpretation of message retrieval. Consider a process P_1 , previously blocked on a read request in a blackboard and now released on a display request by another process P_2 :

1. some implementations assume that the message read by the suspended process P_1 is the same as the one just displayed on the blackboard P_2 ;
2. there are other implementations that display the message retrieved by P_1 when the execution of P_1 is resumed. This is because a higher priority process could be ready to execute when P_1 gets released. So, P_1 does not necessarily read the message displayed by P_2 since the message may have been overwritten while it was suspended.

As one can notice, the level of detail of the model described in Fig. 4, although somewhat abstract, allows to cover both interpretations of the service. In practice, we observe that these interpretations can be useful depending on the context.

- Implementations of type (1) may be interesting when all the messages displayed on the blackboard are relevant to the process P_1 . Every message must be retrieved. However, even if using a blackboard for such message exchanges appears cheaper than using a buffer (in terms of memory space required for message queuing, and of blocked processes

management), it would be more judicious to consider a buffer for such communications since it guarantees that no message is lost.

- On the other hand, implementations of type (2) are useful when P_1 does not need to retrieve all displayed messages. For instance, P_1 only needs to read *refreshed data* of the same type. In that case, only the latest occurrence of message is relevant.

The presence of ambiguities as illustrated above justifies a model refinement design approach, where abstract descriptions are sufficiently general and can be refined progressively in order to derive a particular implementation. Here, the way messages are retrieved during the *read_blackboard* service call is not clear. The model given in Fig. 4 allows to describe such a situation.

A more detailed version of the service model is shown in Fig. 5. This model relies on the second interpretation of the *read_blackboard* service. Its internal properties can now be explicitly specified with respect to interface properties defined in Fig. 4. For that, we start with a functional decomposition of the informal specification of the service [22], and this leads to four main sub-parts as illustrated in Fig. 5. Sub-parts `CHECK_BOARD_ID` and `CHECK_TIMEOUT` verify the validity of inputs `board_ID` and `timeout`. If these inputs are valid, `PERFORM_READ` tries to read the specified blackboard. Only after this it sends the latest message displayed on the blackboard. It also transmits all necessary information to `GET_RETURN_CODE`, which defines the final diagnostic message of the service request. The intermediate signals exchanged by these sub-parts allow us to derive a complete definition of the local signal `C_return_code`, which was only declared previously (see Fig. 4).

In addition, further properties such as clock relations between all identified signals are specified. Finally, each sub-part is developed in a similar way so as to define every signal. The resulting model of the service, which gives the complete SIGNAL code of the service can be found in [21].

The modeling of the other APEX-ARINC services follows the approach. The corresponding models allow us to describe process management, communication and synchronization between processes, etc. The next section presents the definition of the *partition-level OS*, which is in charge of controlling the execution of processes within a partition.

Modeling of the partition-level OS. The role of the partition level OS is to ensure the correct concurrent execution of processes within the partition; each process must have exclusive control on the processor. An example model of the partition level OS is shown in Fig. 6.

The notions taken into account for the modeling of the *partition level OS* are mainly: *process management* (e.g. create, suspend a process), *scheduling* (including the definition of process descriptors and a scheduler), *time management* (e.g. update time counters), *communications*, and *synchronizations* between processes. The APEX interface provides a major part of required services to achieve the notions mentioned above. However, in order to have a complete description of the *partition level OS* functionalities, we added additional services to our library. These services allow us to describe process scheduling within a partition and they also allow to update time counters. Their description can be found in [22]. A case study using these services is presented in [23]. Here, we only present the generic interface of the *partition*

level OS (cf. Fig. 6). We explain how it interacts with the other subparts of its containing partition, in particular processes.

In Fig. 6, the input `Active_partition_ID` represents the identifier of the running partition selected by the module-level OS, and it denotes an execution order when it identifies the current partition. The activation of all partitions depends on this signal. It is produced by the module-level OS, which is in charge of the management of partitions within a module. The presence of the input signal `initialize`, which corresponds to the initialization phase of the partition: creation of all the mechanisms and processes contained in the partition. Whenever the partition executes, the `PARTITION_LEVEL_OS` selects an active process within the partition. The process is identified by the value carried by the output `Active_process_ID`, which is sent to each process. The signal `dt` denotes duration information corresponding to process execution. This is the duration of the current “block” of actions executed by an active process. It is used to update time counter values. The signal `timedout` produced by the partition-level OS carries information about the current status of the time counters used within the partition. For instance, a time counter is used for a wait when a process gets interrupted on a service request with time-out. As the partition-level OS is responsible for the management of time counters, it notifies each interrupted process of the partition with the expiration of its associated time counter. This is reflected by the signal `timedout`.

Modeling of IMA processes. The definition of an IMA process model consists of its computation and control parts. This is depicted in Fig. 7

with the sub-components *CONTROL* and *COMPUTE*. Any process is seen as a reactive component that reacts whenever an execution order (denoted by the input `Active_process_ID`) is received. The input `timeout` notifies processes of time-out expiration. In addition, there are other inputs (respectively outputs) needed for (respectively produced by) the process computations. The *CONTROL* and *COMPUTE* sub-components cooperate in order to achieve the correct execution of the process model.

The *CONTROL* sub-component of the IMA process is a transition system that indicates which statements have to be executed when the process model reacts. It can be encoded quite naturally by an automaton in *SIGNAL*. A process executes whenever it is identified by the numeric input `Active_process_ID`. Depending on the current state of the transition system representing the execution flow of the process, a *block* of actions in the *COMPUTE* sub-component is selected to be executed *instantaneously* (this is represented by the arrow pointing from *CONTROL* to *COMPUTE* in the figure). The *COMPUTE* sub-component is composed of *blocks* of actions that represent elementary pieces of code to be executed without interruption. The statements associated with a block are assumed to *complete within a bounded amount of time*. In the model, a block is executed instantaneously. Therefore, one must take care of what kinds of statements can be put together in a block [20]. An execution of IMA process is a sequence of blocks, and preemption occurs when there are two consecutive blocks that belong to different processes in a sequence. Finally, the execution duration associated with blocks is provided through `dt`. This information can be obtained before or during the execution of the model using *wcet* calculation techniques [33]

or a profiling technique based on SIGNAL [27], as illustrated in [23].

Global view of a partition model. Fig. 8 shows a coarse overview of a partition composed of three processes. In this model, the component GLOBAL_OBJECTS is created for structuring purposes. It mainly includes communication and synchronization mechanisms used by the processes such as `buff`, `sema`.

5.2 A modeling paradigm based on the building blocks

Now, we briefly discuss ongoing efforts in order to carry out our library of components in the *General Modeling Environment* (GME) [29]. The primary purpose is to increase the usability of the library by proposing the same concepts within a non domain-specific tool such as GME. Therefore, without being an expert of synchronous technologies, a user could still be able to design applications based on the IMA modeling approach proposed in POLYCHRONY. Today, we observe that the attention of the industry tends to shift to frameworks based on general-purpose modeling formalisms (e.g. the Unified Modeling Language), in response to a growing industry demand for higher abstraction-levels in the system design process and an attempt to fill the so-called productivity gap. This calls for an effort toward the convergence between the theory of formal methods and the industrial practice and trends in the design of embedded real-time systems.

GME [29] is a configurable object-oriented toolkit, which supports the creation of domain-specific modeling and program synthesis environments. *Metamodels* are proposed in the environment to describe *modeling paradigms*

for specific domains: basic concepts required for model representation from a syntactical viewpoint to a semantical one.

Our modeling paradigm for IMA design in GME, called MIMAD, is represented by the layer on the top in Fig. 9. The layers on the bottom are dedicated to domain-specific technologies. Here, we consider the POLYCHRONY environment, which is associated with the SIGNAL language. However, one can observe that the idea is extensible to further technologies that offer specific useful functionalities to the MIMAD layer (e. g., the integrated environment UPPAAL, which enables validation and verification of real-time systems using timed automata). As GME enables to import and export XML files, information exchange between layers relies on this intermediate format. This favors a high flexibility and interoperability.

The MIMAD layer aims at providing a user with a graphical framework allowing to model applications using a component-based approach. Application architectures can be easily described by just selecting these components via drag and drop. Component parameters (e.g. period or deadline of an IMA process model) can be specified. The resulting GME model is transformed in SIGNAL (referred to as *Mimad2Sig* in Fig. 9) based on the XML intermediate format.

In the synchronous data-flow layer, the XML description obtained from the upper layer is used to generate a corresponding SIGNAL model of the initial application description. This is achieved by using the IMA-based components already defined in POLYCHRONY [22]. Thereon, the formal analysis and transformation techniques available in the platform can be applied to the generated SIGNAL specification. Finally, a feedback is sent to the MI-

MAD layer to notify the user with possible incoherences in initial descriptions.

By defining the MIMAD layer, users can easily design applications based on the IMA modeling approach proposed in POLYCHRONY without being experts of synchronous technologies.

In the next section, a methodology is proposed in order to generalize our design approach for IMA applications in SIGNAL. The key idea is to consider initial SIGNAL program representing an application. This program does not reflect any implementation architecture. By applying some conservative transformations (i.e. they strictly preserve the semantics of manipulated programs) to the program, we obtain a new program that can be instantiated on the IMA architecture using our predefined building blocks.

6 Design by model refinement

By refinement, we mean a set of transformations allowing to define progressively, from an initial SIGNAL description P , further descriptions in the following way: at each step, a new description Q is obtained through the “instantiation” of intermediate variables by adding supplementary equations to P . Typically, this refinement process could modify non-functional properties of P such as temporal properties, by introducing delays during the execution or by relaxing some synchronization relations, but its functional properties are strictly preserved.

6.1 Basic notions

The notions presented below have been introduced during the European project SACRES [24]. Its goal was to define ways for generating distributed code from synchronous specifications (particularly SIGNAL programs). In the following, an application is represented by a SIGNAL program $P = P_1 \mid P_2 \mid \dots \mid P_n$, where each sub-program P_i can be itself recursively composed of other sub-programs (i.e., $P_i = P_{i1} \mid P_{i2} \mid \dots \mid P_{im}$). We assume the following hypotheses:

1. considered programs P are initially *endochronous* [28], hence temporally deterministic (roughly speaking, an endochronous program is temporally insensitive to its environment behavior);
2. they do not contain any circular definitions;
3. a set of processors $q = \{q_1, q_2, \dots, q_m\}$; and
4. a function $locate : \{P_i\} \longrightarrow \mathcal{P}(q)$, which associates with each subpart of an application $P = P_1 \mid P_2 \mid \dots \mid P_n$ a non empty set of processors (the allocation can be done either manually or automatically).

First transformation. Let us consider a SIGNAL program $P = P_1 \mid P_2$, as illustrated in Fig. 10. Each sub-program P_i (represented by a circle) is itself composed of four sub-programs P_{i1} , P_{i2} , P_{i3} and P_{i4} . The program P is distributed on two processors q_1 and q_2 as follows:

$$\begin{aligned} \forall i \in \{1, 2\} \forall k \in \{1, 2\}, \quad locate(P_{ik}) &= \{q_1\} \quad \text{and} \\ \forall i \in \{1, 2\} \forall k \in \{3, 4\}, \quad locate(P_{ik}) &= \{q_2\} \end{aligned}$$

Hence, P can be rewritten into $P = Q_1 \mid Q_2$, where

$$\begin{aligned} Q_1 &= P_{11} \mid P_{12} \mid P_{21} \mid P_{22} \quad \text{and} \\ Q_2 &= P_{13} \mid P_{14} \mid P_{23} \mid P_{24} \end{aligned}$$

The sub-programs Q_1 and Q_2 resulting from the partitioning of P are called *s-tasks* [24]. This transformation yields a new form of the program P that reflects a multi-processor architecture. It also preserves the semantics of the transformed program (since it simply consists of program rewriting).

Second transformation. We want to refine the level of granularity resulting from the above transformation. For that we consider descriptions at processor level, so called s-tasks. We are now interested in how to decompose s-tasks into fine grain entities. An s-task can be seen as a set of *nodes* (e.g. P_{11}, P_{12}, P_{21} and P_{22} in Q_1). In order to get an optimized execution at the s-task level, nodes are gathered in a way such that they can be executed atomically. We therefore distinguish two possible ways to define such subsets of nodes, also referred to as *clusters*: either they are composed of a single SIGNAL primitive construct, or they contain more than one primitive construct. The former yields a finer granularity than the latter. However, from the execution point of view, the latter is more efficient since more actions can be achieved at a same time (i.e. atomically).

The definition of atomic nodes use the following criterion: all expressions contained in a node depend on the same set of inputs. The verification of this condition relies on a *sensitivity analysis*. There exists a causality path

between a node N_1 and a node N_2 if there is at least one situation where the execution of N_2 depends on the execution of N_1 . If this is the case, all possible intermediate nodes are also scheduled to be executed.

Definition 1 *Two nodes N_1 and N_2 are sensitively equivalent iff for each input i : there is a causality path from i to $N_1 \Leftrightarrow$ there is a causality path from i to N_2 .*

Sensitively equivalent nodes belong to the same cluster. Inputs always precede outputs within a cluster. Also, if a transformed program is initially endochronous, the resulting clusters are also endochronous (this ensures a deterministic execution of each cluster). Fig. 11 shows a decomposition of the s-task Q_1 into two clusters L_1 and L_2 . The input of the sub-program P_{11} (bold-faced arrow) is originally an input of P . The other arrows represent communications between s-tasks (These message exchanges are local to P). We can notice that after this second transformation, the semantic equivalence of the initial program and the resulting one is strictly preserved.

The two transformations presented above describe a partitioning of SIGNAL programs following a multi-task multi-processor architecture. The instantiation of such a description in the IMA model consists in using the ARINC component models we have introduced in Section 5.1 (APEX services, processes, partitions).

6.2 Instantiation of SIGNAL programs in the IMA model

We present this instantiation at processor level but the approach can be generalized for the multi-processor level. From the above transformations, a processor can be considered as a graph where nodes are represented by clusters. Therefore, the partitioning of a given SIGNAL program following the IMA architecture model is obtained through the following steps :

- **Step 0: Distribution on available processors.** Here, we assume a given distribution function. The program is transformed into s-tasks. In practice, this step is often an expert matter. However, there exist tools that can help to achieve this kind of task (e.g SYNDEX [25]).
- **Step 1: For each processor, transform the associated s-task into a graph of clusters.** This task is done automatically by the SIGNAL compiler.
- **Step 2: For each processor, associate clusters with partitions/processes.** The first decision about the graph of clusters resulting from the previous step consists in choosing a partitioning of clusters into IMA partitions/processes. In other words, we have to identify clusters that can be executed within the same partition/process. In our simple example, we decide to model the graph associated with $Q1$ (cf. Fig. 11) by one partition. Once partitions are chosen, each graph corresponding to a partition is decomposed into sub-graphs. These contain the clusters that should be executed by the same process. In the example, clusters associated with the “partition $Q1$ ” form

the set of instruction blocks of a single process. The decomposition of a graph of clusters into partitions and processes has to be done with respect to coherent criteria. For instance, it can be very interesting to put clusters that strongly depend on each other together in a same partition/process. This would greatly reduce inter-process communication costs. In the next step, the program can be effectively instantiated using our building blocks.

- **Step 3: Instantiate the program in the IMA model.** Two phases are considered: we first instantiate processes then partitions. An overview of used basic components is given in Fig. 12. The symbol “|” denotes the synchronous composition. The following transformations are defined:

1. Description of the process associated with a set of clusters:
 - The definition of the CONTROL part of the process relies on dependencies between clusters. Clusters are executed sequentially with respect to these dependencies.
 - Each cluster is “embedded” in a block within the COMPUTE part of the process.
 - Internal communications between the clusters of a sub-graph associated with a process are modeled using local state variables (i.e. those defined by the *delay* primitive construct). These variables enable to memorize exchanged data. On the other hand, communications between sub-graphs of clusters from different processes are modeled with APEX services. For

each entry point (resp. exit point) of a sub-graph, a block containing a suitable communication or synchronization service call is added in the COMPUTE part of the associated process model. When the process becomes active, this block is executed just before (resp. after) the block that contains the cluster concerned by the entry point (resp. the exit point). The choice of the suitable service to call here depends on the desired type of communication. For instance, if one needs to use a bounded message queue, services associated with a buffer are preferred to those related to a blackboard, which are more appropriate for message exchanges via one memory-place. Services associated with semaphore are used for synchronization.

2. Description of the partition associated with a set of clusters:
 - The component corresponding to the partition-level OS (containing among other things the scheduler, which manages process execution within the partition) is added to processes defined at the previous phase.
 - The communication and synchronization mechanisms used by the APEX services added in the previous phase are created (for instance, for a *send_buffer* service call, a *buffer* should be created in which messages can be stored). This creation is done for example within the GLOBAL_OBJECTS sub-part of the partition, as illustrated on Fig. 8.

Example *Fig. 13 outlines a process model resulting from the transformation of Q1. There are six blocks two of which contain the clusters L1 and L2. The other blocks have been added for communication: r , s and w respectively denote a read request (receive_buffer or read_blackboard), an event notification (set_event), and an event notification waiting (wait_event). The automaton described in the control part gives the execution order of the blocks with respect to the precedence constraints of the cluster graph. It is derived following the identified dependencies. The corresponding partition is obtained by considering the phase 2 of **Step 3**, in the current section.*

For each processor with multiple partitions, a model of partition scheduler is required. Partition management is done based on a time sharing strategy, so we have to compose a component (corresponding to the module-level OS - see Section 2.2) with partition models. A model of such a component is similar to the partition-level OS in that its definition relies on the use of APEX services, except that the scheduling policy differs.

6.3 Discussion

One major characteristic of our study is the use of formal techniques in order to address design obstacles in safety-critical domains such as avionics. In the proposed solution, we advocate a correctness by construction philosophy, which facilitates validation issues. As a result, global design costs can be significantly reduced. More generally, we use the synchronous technology, which provides designers with tools and techniques with solid mathematical foundations for specification, verification and analysis, and automatic code

generation. In particular, we consider the SIGNAL language associated with its synchronous multi-clock (or polychronous) semantic model to describe avionic applications. We primarily define SIGNAL models of basic architectural concepts based on the ARINC standard: execution entities and real-time operating system functionalities (see Section 2.2). These models are specific to IMA. They are used in our global design methodology, which consists in *i*) refining SIGNAL specifications that represent applications, and *ii*) instantiating the resulting descriptions using the models so as to feature an IMA architecture.

We note that our methodology combines both component-based approach and model refinement approach. While the latter favors correctness by construction, the former enables re-usability. These are essential to the safe and cost-effective design activity in critical domains. In this context, the Radio Technical Commission for Aeronautics (RTCA) and the European Organization for Civil Aviation Equipment (EUROCAE) have been working on a standard document with the draft title, "Integrated Modular Avionics (IMA) Development Guidelines and Certification Considerations" where special emphasis is put on the dependable development of IMA modules, applications, and systems using reusable components.

Our methodology enables to address the scalability issue. Typically, for large applications, one may need to redefine the granularity for clusters. This can be achieved by putting together clusters (as described in Section 6) within a new version of cluster based on a coherent criterion (e.g., clusters that strongly depend on each other are put together). The overall resulting description can be thereon instantiated in the IMA model (following **step**

3 in the methodology).

Another important issue is usability. Our methodology is entirely developed within POLYCHRONY, the design environment associated with the SIGNAL language. This means that some knowledge of synchronous programming is a prerequisite to use the provided models. However, as illustrated in Section 5.2, we are currently modeling the same concepts within the GME environment, which is not a domain-specific tool. This supplementary layer will be connected to POLYCHRONY so as to provide users with access to our SIGNAL models.

Compared to existing related work, we can mention common points between our study and di Vito's work [17] in that guaranteeing the correctness of partitioning is a major objective. However, in [17], the author first considers a given application partitioning and then addresses correctness issues. Here, we rather use the data-flow representation offered by the SIGNAL language to get a correct-by-construction partitioning, based on the sensitivity analysis. Akin to COTRE [13] and AADL [19], our work aims at providing a solution to design and validation problems for avionic applications. However, our approach entirely relies on the single semantic model of the SIGNAL language. This is not the case in COTRE and AADL where different kinds of formalism are considered for specification, verification, and analysis. Using different formalisms can lead to difficult validation activity. Finally, we mention the SCADE approach [14], which is close to our approach. While both rely on the synchronous technology, they do not have the same vision of a system execution: the approach exposed in this article considers an operating system based computation whereas SCADE uses the cycle-based

computation model.

7 Conclusions

In this article, we present a design methodology based on model refinement for avionic applications deployed on integrated modular avionics architectures (IMA). This methodology relies, on the one hand, on systematic and conservative transformations of SIGNAL programs and, on the other hand, on the use of a library of component models (also described in SIGNAL) specified by the avionic standard ARINC. For a given application, an associated initial SIGNAL specification is first considered, which is independent of a specific implementation platform. This application is distributed on a multi-processor architecture with the help of a specific distribution function. Each resulting sub-part is now refined using transformations that strictly preserve the semantics of the application. Finally, on each processor, our ARINC component models are used to instantiate the transformed application sub-parts such as to reflect IMA architecture.

Beyond the fact that our approach promotes a design activity within a formal framework and therefore simplifies validation issues, it suggests a solution to critical issues in partitioning of avionics. Indeed, the lack of techniques that efficiently cope with these issues makes federated architectures still very attractive from IMA ones. As a result, IMA architectures and operating systems do not currently extend to the most critical avionic functions. For instance, flight-critical systems such as the aircraft environment surveillance system (AESS) or the flight management system (FMS)

employ separate hardware assemblies and operating systems. The sensitivity analysis described in our approach provides a correct by construction way enabling an easy identification of dependencies between sub-parts of an application, which favors a reliable partitioning of the application.

Our methodology is defined within the POLYCHRONY platform that offers a set of tools and techniques for model transformation and analysis based on the SIGNAL language (<http://www.irisa.fr/espresso/Polychrony>). A library of APEX-ARINC component models is available within the platform.

Acknowledgments

This work has been partly supported by the European project IST SAFEAIR (*Advanced Design Tools for Aircraft Systems and Airborne Software* - see the following address: <http://www.safeair.org>).

References

- [1] Airlines Electronic Engineering Committee. ARINC 629: IMA Multi-transmitter databus parts 1-4. Technical Report 629, Aeronautical radio, Inc., Annapolis, Maryland, October 1990.
- [2] Airlines Electronic Engineering Committee. ARINC 659: Backplane data bus. Technical Report 659, Aeronautical radio, Inc., Annapolis, Maryland, December 1993.

- [3] Airlines Electronic Engineering Committee. ARINC report 651-1: Design guidance for integrated modular avionics. Technical Report 651, Aeronautical radio, Inc., Annapolis, Maryland, November 1997.
- [4] Airlines Electronic Engineering Committee. ARINC specification 653: Avionics application software standard interface. Technical Report 653, Aeronautical radio, Inc., Annapolis, Maryland, January 1997.
- [5] P. Amey. Correctness by construction: Better can also be cheaper. *CrossTalk Magazine, The journal of Defense Software Engineering*, March 2002.
- [6] C. André. Computing syncharts reactions. In *Proc. of Synchronous Lang., Applications, and Programming (SLAP'03), Porto - Portugal*, July 2003.
- [7] N.C. Audsley and A.J. Wellings. Analysing APEX Applications. In *Proceedings of Real Time Systems Symposium (RTSS'96), Washington, DC, USA, IEEE Computer Society*, December 1996.
- [8] P. Beaufreton, H. Granier, X. Méhaut, and E. Rutten. The SACRES approach to embedded systems applied to aircraft engine controllers. In *Proc. of the 22nd IFAC/IFIP Workshop on Real-Time Program., Lyon - France*, Sep. 1997.
- [9] G. Bel, F. Boniol, G. Durrieu, C. Fraboul, J. Foisseau, and V. Wiels. Modèles comportementaux pour l'avionique modulaire intégrée. In *1er Congrès pluri-sectoriel - Logiciel Temps Réel Embarqués - Météo France, Toulouse*, pages 677–691, January 2002.
- [10] A. Benveniste, P. Caspi, S. Edwards, N. Halbwachs, P. Le Guernic, and R. de Simone. The synchronous languages twelve years later. *Proceedings of the IEEE*, 91(1):64–83, January 2003.
- [11] A. Benveniste, P. Le Guernic, and C. Jacquemot. Programming with events and relations: the SIGNAL language and its semantics. *Science of Computer Programming*, 16(2):103–149, November 1991.

- [12] G. Berry and G. Gonthier. The ESTEREL synchronous programming language : design, semantics, implementation. *Science of Computer Programming*, 19(2):87–152, November 1992.
- [13] B. Berthomieu *et al.* Towards the Verification of Real-Time Systems in Avionics: the Cotre Approach. In *8th International workshop for industrial critical systems, ROROS, Thomas Arts, Wan Fokkink (eds)*, pages 201–216, June 2003.
- [14] J.-L. Camus and B. Dion. Efficient development of airborne software with SCADE suite. In *Esterel Technologies white paper*, 2003. <http://www.esterel-technologies.com>.
- [15] D. Cofer and M. Rangarajan. Formal modeling and analysis of advanced scheduling features in an avionics RTOS. In *proceedings of Conference on Embedded Software (EMSOFT'02)*, J. Sifakis and A. Sangiovanni-Vincentelli, Eds, LNCS 2491, Springer Verlag, p. 138-152, 2002.
- [16] P. Conmy and J. McDermid. High Level Failure Analysis for Integrated Modular Avionics. In *Proceedings of the 6th Australian Workshop on Industrial Experience with Safety Critical Systems and Software, Brisbane, Australia*, June 2001.
- [17] B.L. Di Vito. A Model of Cooperative Noninterference for Integrated Modular Avionics. In *Proceedings of Dependable Computing for Critical Applications (DCCA-7)*, San Jose, CA, January 1999.
- [18] Esterel Technologies. SCADE language reference manual. 2004. <http://www.esterel-technologies.com>.
- [19] P.H. Feiler, B. Lewis, and S. Vestal. The SAE Avionics Architecture Description Language (AADL) Standard: A Basis for Model-Based Architecture-Driven Embedded Systems Engineering. In *Proceedings of Workshop on Model-Driven Embedded Systems, Washington D.C., USA*, May 2003.

- [20] A. Gamatié. *Modélisation polychrone et évaluation de systèmes temps réel*. PhD thesis, Université de Rennes I, Rennes, France, May 2004.
- [21] A. Gamatié and T. Gautier. Synchronous modeling of modular avionics architectures using the SIGNAL language. Technical Report 4678, INRIA, December 2002. Available at <http://www.inria.fr/rrrt/rr-4678.html>.
- [22] A. Gamatié and T. Gautier. Synchronous modeling of avionics applications using the SIGNAL language. In *Proc. of the 9th IEEE Real-time/Embedded technology and Applications symposium (RTAS'03)*. Washington D.C., USA, May 2003.
- [23] A. Gamatié, T. Gautier, and P. Le Guernic. An example of synchronous design of embedded real-time systems based on IMA. In *Proceedings of the 10th International Conference on Real-time and Embedded Computing Systems and Applications (RTCSA'04)*. Gothenburg - Sweden, August 2004.
- [24] T. Gautier and P. Le Guernic. Code generation in the SACRES project. In *Safety-critical Systems Symposium (SSS'99)*, Springer. Huntingdon, UK, February 1999.
- [25] T. Grandpierre and Y. Sorel. From algorithm and architecture specifications to automatic generation of distributed real-time executives: a seamless flow of graphs transformations. In *Formal Methods and Models for Codesign Conference (MEMOCODE'03)*, Mont Saint-Michel, France, June 2003.
- [26] N. Halbwachs, F. Lagnier, and C. Ratel. Programming and verifying real-time systems by means of the synchronous data-flow programming language LUSTRE. *IEEE Trans. on Software Engineering*, 18(9):785–793, Sep. 1992.
- [27] A. Kountouris and P. Le Guernic. Profiling of SIGNAL programs and its application in the timing evaluation of design implementations. In *IEE Colloq.*

- on HW-SW Cosynthesis for Reconfigurable Systems, IEE*, pages 6/1–6/9. HP Labs, Bristol, UK, February 1996.
- [28] P. Le Guernic, J.-P. Talpin, and J.-C. Le Lann. Polychrony for system design. *Journal for Circuits, Systems and Computers*, 12(3):261–304, April 2003.
- [29] A. Ledeczi and al. The Generic Modeling Environment. In *Proc. of the IEEE Workshop on Intelligent Signal Processing (WISP'01)*, May 2001. For more details, see www.isis.vanderbilt.edu/Projects/gme.
- [30] Y.-H. Lee *et al.* Resource Scheduling in Dependable Integrated Modular Avionics. In *Proceedings of the International Conference on Dependable Systems and Networks*, April 2000.
- [31] B. Lewis, S. Vestal, and D. McConnell. Modern avionics requirements for the disubuted system annex. In *Ada-Europe'98, L. Asplund, Ed, LNCS 1411, Springer Verlag, p. 201-212*, 1998.
- [32] A. Pnueli. Embedded Systems: Challenges in Specification and Verification. In *2002 Conference on Embedded Software, J. Sifakis and A. Sangiovanni-Vincentelli, Eds, LNCS 2491, Spr. Verlag., p. 252-265*, 2002.
- [33] P. Puschner and A. Burns. A review of worst-case execution-time analysis. *Journal of Real-Time Systems*, 18(2/3):115–128, May 2000.
- [34] J. Rushby. Partitioning in avionics architectures: Requirements, mechanisms, and assurance. Technical Report CR-1999-209347, NASA Langley Research Center, June 1999. Available at <http://www.csl.sri.com/users/rushby/partitioning.html>.
- [35] M.A. Sánchez-Puebla and J. Carretero. A new Approach for Distributed Computing in Avionics Systems. In *Proceedings of the 1st International Symposium on Information and Communication Technologies, Dublin, Ireland, 2003*.

- [36] S. Vestal. METAH Support for Real-Time Multi-Processor Avionics. In *Proceedings of the IEEE Workshop on Parallel and Distributed Real-Time Systems*, April 1997.

Fig. 1: Example of IMA infrastructure for the Boeing B777.

Fig. 2: Example of IMA infrastructure for the Airbus A380.

Fig. 3: A sketch of the model-based development with SCADE.

Fig. 4: Abstract SIGNAL description of *read_blackboard*.

Fig. 5: Refined description of *read_blackboard* and clock relations between signals.

Fig. 6: Interface of the partition level OS model.

Fig. 7: IMA process model.

Fig. 8: An example of partition model composed of three processes.

Fig. 9: A component-oriented modeling framework for IMA design.

Fig. 10: Decomposition of a SIGNAL process into two s-tasks Q_1 and Q_2 .

Fig. 11: Decomposition of an s-task into two clusters L_1 and L_2 .

Fig. 12: Modeling rules for IMA partitions.

Fig. 13: A process model resulting from the transformation of Q_1 .

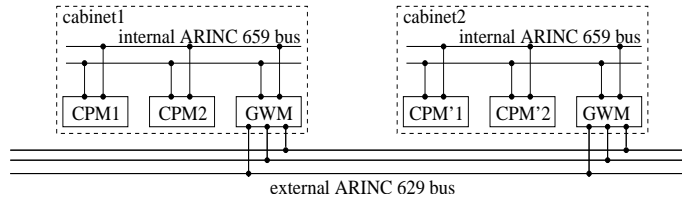

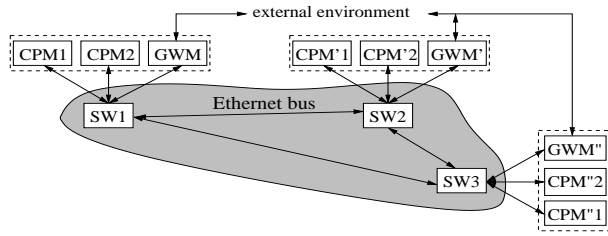

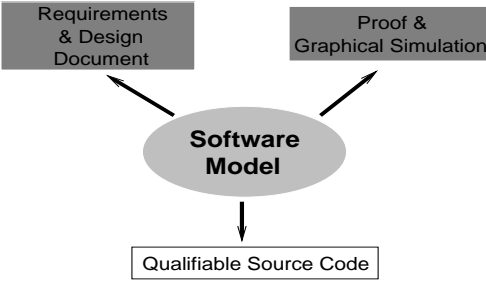

```

process READ_BLACKBOARD =
{ ProcessID_type process_ID; }
( ? Comm_ComponentID_type board_ID;
  SystemTime_type timeout;
  ! MessageArea_type message;
  MessageSize_type length;
  ReturnCode_type return_code; )
(| (| { {board_ID, timeout} -->
      return_code } when C_return_code      (d.1)
  | { {board_ID, timeout} --> {message, length} }
      when (return_code = #NO_ERROR)        (d.2)
  |)
| (| board_ID ^= timeout ^= C_return_code   (s.1)
  | return_code ^= when C_return_code       (s.2)
  | message ^= length ^= when (return_code = #NO_ERROR) (s.3)
  |)
|) where boolean C_return_code

```

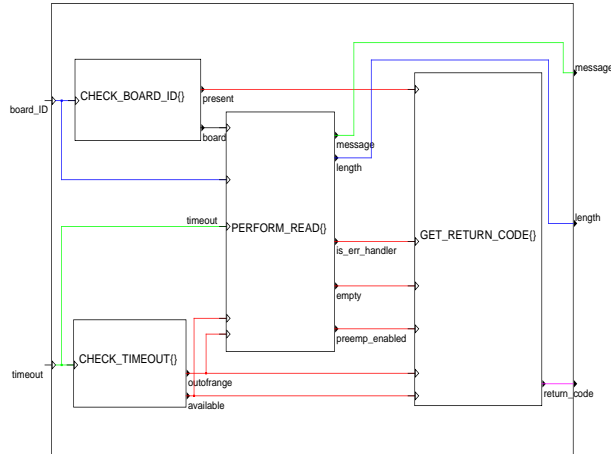

```

(| board_ID ^= timeout ^= present ^= outofrange ^= available
    ^= C_return_code
| board ^= empty ^= when present
| message ^= length ^= when (not empty)
| is_err_handler ^= when empty when available
| preemp_enabled ^= when (not is_err_handler)
| C_return_code := (when ((not present) or outofrange)) default
    (when empty when (not available)) default
    (when ((not preemp_enabled) default is_err_handler)) default
    (when (not empty)) default
    false
| return_code ^= when C_return_code
|)

```

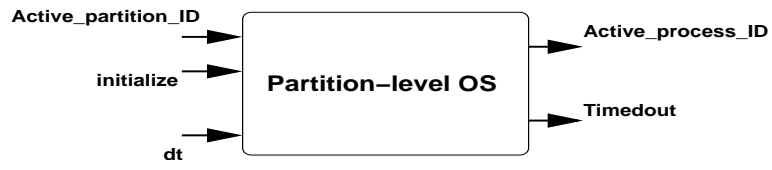

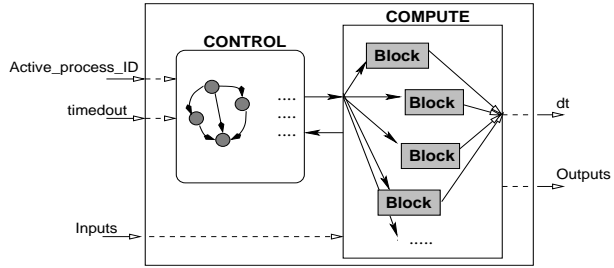

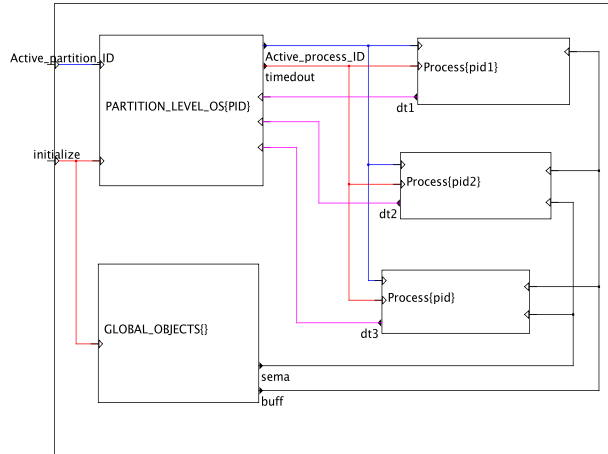

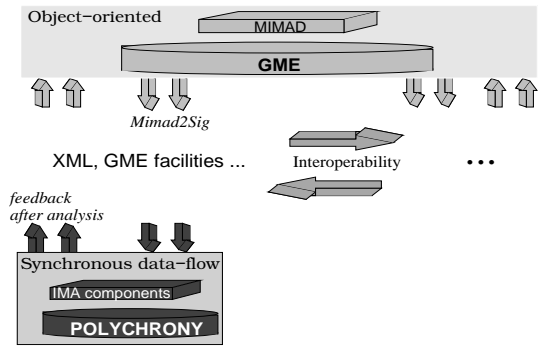

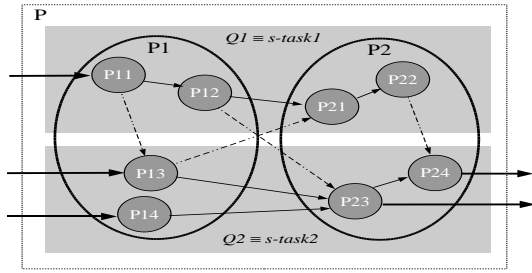

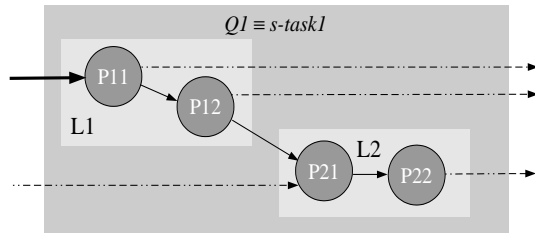



	$p - OS$	(partition-level OS)
	$cont_i$	(“control“ part of a process p_i)
	b_{ij}	(block)
$comp_i$	$::= b_{i1} \mid \dots \mid b_{im_i}$	(“compute“ part of a process p_i)
p_i	$::= cont_i \mid comp_i$	(process)
p	$::= p - OS \mid p_1 \mid \dots \mid p_n$	(partition)

