



# Extended interface ID for virtual link selection in GeoNetworking to IPv6 Adaptation Sub-layer (GN6ASL)

Manabu Tsukada, Masatoshi Kakiuchi, Thierry Ernst

## ► To cite this version:

Manabu Tsukada, Masatoshi Kakiuchi, Thierry Ernst. Extended interface ID for virtual link selection in GeoNetworking to IPv6 Adaptation Sub-layer (GN6ASL). 2012. hal-00763640

**HAL Id: hal-00763640**

**<https://hal.inria.fr/hal-00763640>**

Submitted on 11 Dec 2012

**HAL** is a multi-disciplinary open access archive for the deposit and dissemination of scientific research documents, whether they are published or not. The documents may come from teaching and research institutions in France or abroad, or from public or private research centers.

L'archive ouverte pluridisciplinaire **HAL**, est destinée au dépôt et à la diffusion de documents scientifiques de niveau recherche, publiés ou non, émanant des établissements d'enseignement et de recherche français ou étrangers, des laboratoires publics ou privés.

# Extended interface ID for virtual link selection in GeoNetworking to IPv6 Adaptation Sub-layer (GN6ASL)

11th December 2012

**Manabu Tsukada**, INRIA, France  
**Masatoshi Kakiuchi**, NAIST, Japan  
**Thierry Ernst**, Mines ParisTech, France

## Contents

<b>1</b>	<b>Background</b>	<b>1</b>
<b>2</b>	<b>Problem statement</b>	<b>2</b>
<b>3</b>	<b>Identifier in each layer</b>	<b>4</b>
3.1	MAC address . . . . .	4
3.2	GeoNetworking Address . . . . .	4
3.3	IPv6 unicast addresses . . . . .	4
3.4	IPv6 Address on GN6ASL virtual interfaces . . . . .	5
<b>4</b>	<b>Extended interface ID format to identify virtual links</b>	<b>6</b>
4.1	Generation of Extended interface ID . . . . .	6
4.2	GN6ASL operation with Extended interface ID . . . . .	7
<b>5</b>	<b>Consideration</b>	<b>7</b>
<b>6</b>	<b>Conclusion</b>	<b>8</b>

## 1 Background

Intelligent Transportation Systems (ITS) are systems deployed to optimize the road traffic and realize safe, efficient and comfortable human mobility. Cooperative ITS is a new vision of ITS where vehicles, the roadside infrastructure, traffic control centers, road users, road authorities, road operators, etc. exchange and share information based on a common communication architecture — known as the ITS station reference architecture [[ISO-21217-CALM-Arch](#), [ETSI-EN-302-665-Arch](#)] — supporting all types of ITS use cases

over a diversity of access technologies (11p, 11n, 3G/4G, infra-red, ...). The building blocks of the ITS station are specified within ISO, ETSI, IETF and IEEE.

[ETSI-TS-102-636-6-1-GN6] specifies the transmission of IPv6 packets over ETSI GeoNetworking protocol [ETSI-TS-102-636-4-1-GN] via a protocol adaptation sub-layer referred as the GN6ASL (GeoNetworking to IPv6 Adaptation Sub-layer) (See Figure 1).

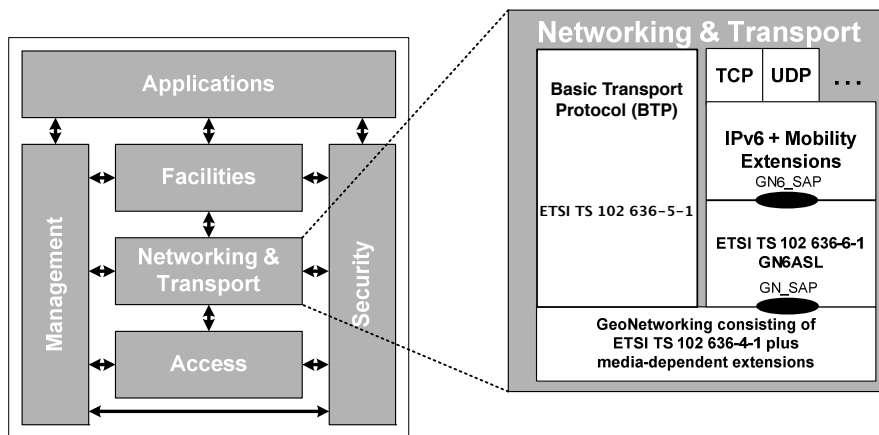

Figure 1: GN6ASL in the ITS station architecture

## 2 Problem statement

We describe the limitation of Draft EN 302 636-6-1 V0.1.2 (2012-11) in this Section. Note that this study is based on year December 2012 versions of the ETSI Standards and that the standards constantly evolve. As a result, parameters, primitives and virtual links on GN6ASL may have changed at the time of reading.

Figure 2 illustrates the overview of the addressing scheme in each layer from access layer to IPv6 layer in ITS Station Architecture. As illustrated in the figure, a 48bits MAC address is used for ITS-G5A media in the access layer in order to identify the physical communication interface (detailed in section 3.1). In the GeoNetworking layer, a GeoNetworking (GN) address is used in order to identify the node. The GeoNetworking address is generated based on the MAC address used in the access layer [ETSI-TS-102-636-4-1-GN] (detailed in section 3.2).

A GeoNetworking node may have several Geographical Virtual Links (GVL) and a Topological Virtual Interface (TVL) in GN6ASL. Each virtual link may be seen as an virtual interface in the IPv6 layer. The current specification [ETSI-TS-102-636-6-1-GN6] defines that the IPv6 link-local address assigned to the virtual interfaces contain interface identifier (IID) generated from MAC address (see section 3.3 for detail).

The issue of the current specification is that the GN6ASL cannot distinguish destination GVL/TVL for incoming packets by checking the destination address of IPv6 header. Let's see what happens when an incoming packet is received in the node in Figure 2. First, the destination MAC address is checked in the access layer, then if it matches to the MAC address of the received communication interface (MAC address "M"), the packet are

## 2. PROBLEM STATEMENT

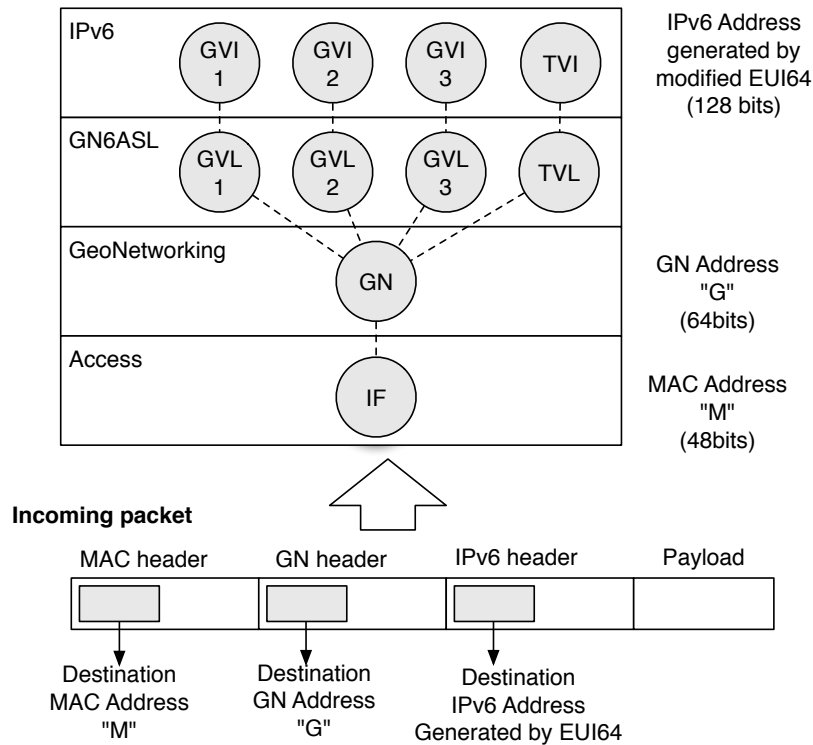

Figure 2: Problem Statement

delivered to the GeoNetworking layer. The GeoNetworking layer checks the destination GeoNetworking address (if GeoUnicast), and if the destination GeoNetworking address is matched to the received node's one (GN address "G"), the packet is sent to the upper layer. GN6ASL needs to select the virtual interface to the IPv6 layer, however one problem arises here. GN6ASL cannot select the destination virtual interface because all the virtual interfaces have same link-local address generated by modified EUI64 as in the GN6 specification.

The current specification of GN6 gives some solution for this issues. It examines the source node position vector in order to determine the GVL to send the packets to the IPv6 layer.

Typically this solution gives a problem in the situation illustrated in Figure 3. Node X sends ICMPv6 echo request to an specific GVL area, however the ICMPv6 echo reply is received in different interface.

Thus it requires the way to allocate different IPv6 address on each virtual interface in order to distinguish them without changing the addressing scheme in MAC address and GeoNetworking address.

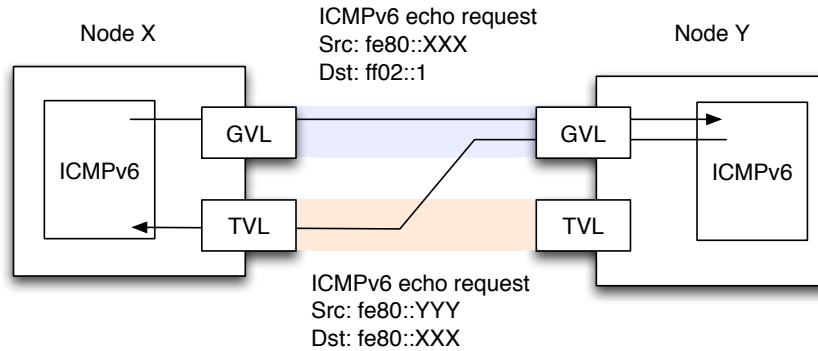

Figure 3: Problem of link-local communications

### 3 Identifier in each layer

#### 3.1 MAC address

Media Access Control address (MAC address) is a unique identifier assigned to network interfaces for communications on the physical network segment.

#### 3.2 GeoNetworking Address

Every GeoAdhoc router shall have a unique GeoNetworking address. This address shall be used in the header of a GeoNetworking packet and identify the communicating GeoNetworking entities. The format of the GeoNetworking address is described in figure 4.

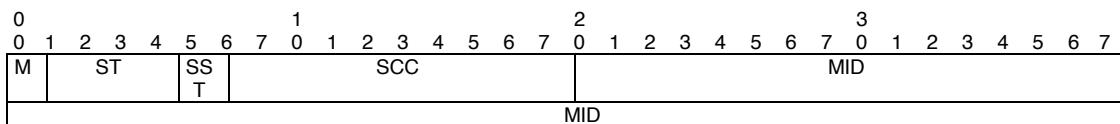

Figure 4: GeoNetworking address format[ETSI-TS-102-636-4-1-GN]

The GeoNetworking address shall be comprised of the fields specified in table 1.

#### 3.3 IPv6 unicast addresses

IPv6 addresses are 128-bit identifiers for interfaces and sets of interfaces. There are three types of addresses: Unicast, Anycast and Multicast. IPv6 addresses of all types are assigned to interfaces, not nodes. An IPv6 unicast address refers to a single interface. In IPv6 nodes, all interfaces are required to have at least one Link-Local unicast address [rfc4291].

IPv6 unicast address consists of subnet prefix and interface identifier. Interface identifiers in IPv6 unicast addresses are used to identify interfaces on a link. They are required to be unique within a subnet prefix. Generally, Interface IDs are required to be 64 bits long and to be constructed in Modified EUI-64 format.

Modified EUI-64 format-based interface identifiers may have universal scope when derived from an universal token (e.g., IEEE 802 48-bit MAC or IEEE EUI-64 identifiers

### 3. IDENTIFIER IN EACH LAYER

Field #	Field name	Octet/bit position		Type	Description
		First	Last		
1	M	Octet 0 Bit 0	Octet 0 Bit 0	1 bit unsigned integer	This bit allows distinguishing between manually configured network address and the initial GeoNetworking address. M is set to 1 if the address is manually configured otherwise it equals 0.
2	ST	Octet 0 Bit 1	Octet 0 Bit 4	4 bit unsigned integer	ITS Station Type. To identify the ITS Station type. Bit 1: 0 - Vehicle ITS station. 1 - Roadside ITS station. Bit 2 to Bit 4: <b>For Roadside ITS station:</b> 0 - Traffic light. 1 - Ordinary Roadside ITS station. <b>For Vehicle ITS station:</b> 0 - Bike. 1 - Motorbike. 2 - Car. 3 - Truck. 4 - Bus.
3	SST	Octet 0 Bit 5	Octet 0 Bit 5	1 bit unsigned integer	ITS Station sub-type. To distinguish between public transport and private ITS stations. 0 - Public (e.g. school bus, public safety vehicle). 1 - Private (e.g. non-public transport vehicle).
4	SCC	Octet 0 Bit 6	Octet 1 Bit 7	10 bit unsigned integer	ITS Station Country Code.
5	MID	Octet 2	Octet 7	48 bit address	This field represents the LL_ADDR.

Table 1: Fields of the GeoNetworking address[[ETSI-TS-102-636-4-1-GN](#)]

[[IEEE-EUI-64](#)]) or may have local scope where a global token is not available (*e.g.*, serial links, tunnel end-points) or where global tokens are undesirable (*e.g.*, temporary tokens for privacy [[rfc4941](#)]).

Modified EUI-64 format interface identifiers are formed by inverting the "u" bit (universal/local bit in IEEE EUI-64 terminology) when forming the interface identifier from IEEE EUI-64 identifiers. In the resulting Modified EUI-64 format, the "u" bit is set to one (1) to indicate universal scope, and it is set to zero (0) to indicate local scope. [[IEEE-EUI-64](#)] defines a method to create an IEEE EUI-64 identifier from an IEEE 48-bit MAC identifier. This is to insert two octets, with hexadecimal values of 0xFF and 0xFE, in the middle of the 48-bit MAC (between the company ID and vendor-supplied ID).

#### 3.4 IPv6 Address on GN6ASL virtual interfaces

ITS-G5A media have IEEE 802 48-bit MAC addresses. GN6ASL assumes interface identifiers for virtual interfaces are modified EUI-64 format-based interface identifiers constructed from 48-bit MAC addresses.

## 4 Extended interface ID format to identify virtual links

We propose a solution to allocate different IPv6 address on each virtual interface in order to distinguish them without changing the addressing scheme in MAC address and GeoNetworking address. The proposition complies also with Dynamic Geographical Virtual Link (DVL) proposed in [INRIA-report-DVL] that is going to be applied to [ETSI-TS-102-636-6-1-GN6].

### 4.1 Generation of Extended interface ID

Instead of inserting 0xFF 0xFE in the middle of the 48-bit MAC between the company ID and vendor-supplied ID in the modified EUI-64 format, our proposition inserts the ID to distinguish the virtual link (Figure 5). The company ID and vendor-supplied ID of MAC address is treated as EUI-64 does. In other words, the only change from MAC address is inverting the value of the universal/local bit in company ID (indicated as “B” bit in Figure 5).

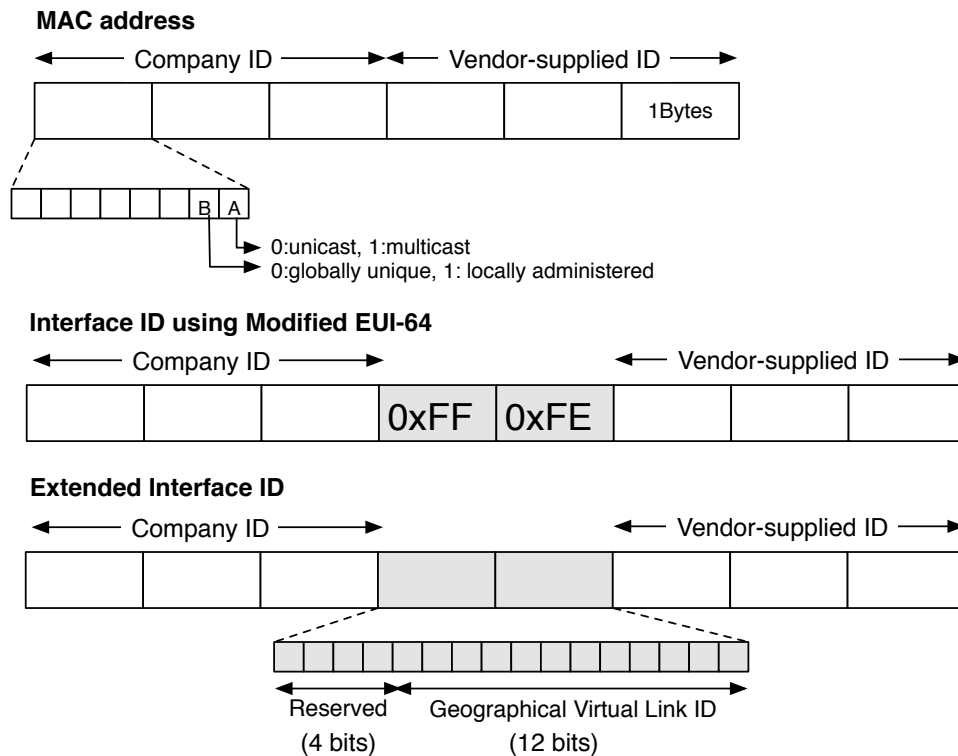

Figure 5: Generation of Extended Interface ID

Proposed Extended interface ID has Reserved bits (4 bits) and Geographic Virtual Link ID (12bits) in the middle of company ID and vendor supplied ID.

**Geographical Virtual Link ID** A 12 bits ID assigned to a virtual link in order to distinguish the virtual link. Virtual link ID is unique in the all the virtual link created from a single physical interface. GN6ASL allocates ID 0 to DVL [INRIA-report-DVL]

(which is created only one per a single physical interface) and from ID 1 to ID 4095 are allocated GVLs when it is created upon reception of RA. When number of GVL created in a GVL exceed 4095, the ID of unused GVL can be reused.

**Reserved bits** 4 bits are reserved in order to record the property of the links. The bits are not yet specified, however they will indicates whether global uniqueness of ID or locally administrated, and whether the link is multicast-capable or not.

The interface ID by EUI-64 (with 0xFFFFE) is allocated to TVL in order to keep compatibility with unsupported nodes. Table 2 summarized the assignment of interface ID to TVL, DVL and GVL.

Type of Link	Assignment of Interface ID
TVL	TVL is created only one to a single physical interface upon enabling the interface. EUI-64 (with 0xFFFFE) is assigned in order to keep compatibility with unsupported node.
DVL	DVL is created only one to a single physical interface upon enabling the interface. GVL ID = 0 is allocated.
GVL	GVL is created upon each reception of different RA. An unique GVL ID from 1 to 4095 is assigned. The ID of unused GVL can be reused.

Table 2: Assignment of Interface ID on virtual links

## 4.2 GN6ASL operation with Extended interface ID

When a outbound packet is sent, GN6ASL resolves the destination MAC address by exactly same way described in section 10.3 in [ETSI-TS-102-636-6-1-GN6] (Non-ND-based address resolution) for both packets which has the IPv6 destination with Interface ID by EUI64 and the proposed scheme.

When a inbound packet is received, GN6ASL selects the virtual link matched to the destination IPv6 address (if exists). If the matched virtual link is not found, GN6ASL passes the packet to the IPv6 layer with default virtual link (this is proposed to be DVL in [INRIA-report-DVL]). In the case that the IPv6 destination address is not on the virtual link, the importance of selected virtual link is low, because these packets are forwarded or dropped in the IPv6 layer, and not passed to upper layer than the IPv6 layer.

## 5 Consideration

The 4bits reserved bits shall indicate the property of the virtual link. Further discussion is necessary what is important property in the virtual link. This maybe whether global uniqueness of ID or locally administrated, and whether the link is multicast-capable or not.



## 6 Conclusion

In the document, we presented the limitation of Draft EN 302 636-6-1 V0.1.2 (2012-11) at this moment. In order to overcome all of these issues, extended interface ID is proposed. We propose a solution to allocate different IPv6 address on each virtual interface in order to distinguish them without changing the addressing scheme in MAC address and GeoNetworking address. The proposition complies also with Dynamic Geographical Virtual Link (DVL) proposed in [INRIA-report-DVL] that is going to be applied to [ETSI-TS-102-636-6-1-GN6]. Instead of inserting 0xFF 0xFE in the middle of the 48-bit MAC between the company ID and vendor-supplied ID in the modified EUI-64 format, our proposition inserts the ID to distinguish the virtual link. Proposed Extended interface ID has Reserved bits (4 bits) and Geographic Virtual Link ID (12bits) in the middle of company ID and vendor supplied ID.

As considerations, we leave the reserved bits undefined at this moment. We consider that further discussion is necessary in ETSI ITS\_WG3 (*ITS\_WG3@LIST.ETSI.ORG*) for approval of the specification of [ETSI-TS-102-636-6-1-GN6].

## References

- [ETSI-EN-302-665-Arch] Intelligent Transport Systems (ITS); Communications Architecture, September 2010. ETSI EN 302 665 V1.1.1 (2010-09). pages 1
- [ETSI-TS-102-636-4-1-GN] Intelligent Transport Systems (ITS); Vehicular Communications; Part 4: Geographical Addressing and Forwarding for Point-to-Point and Point-to-Multipoint Communications; Sub-part 1: Media-Independent Functionality, June 2011. ETSI TS 102 636-4-1 V1.1.1 (2011-06). pages 2, 4, 5
- [ETSI-TS-102-636-6-1-GN6] Intelligent Transport Systems (ITS); Vehicular Communications; GeoNetworking; Part 6: Internet Integration; Sub-part 1: Transmission of IPv6 Packets over GeoNetworking Protocols, March 2011. ETSI TS 102 636-6-1 V1.1.1 (2011-03). pages 2, 6, 7, 8
- [IEEE-EUI-64] Guidelines for 64-bit Global Identifier (EUI-64) Registration Authority, March 1997. pages 5
- [INRIA-report-DVL] Manabu Tsukada, Masatoshi Kakiuchi, and Thierry Ernst. Proposition of Dynamic Virtual Link for IPv6 GeoNetworking (GN6) in ETSI. Technical report, INRIA, November 2012. Proposition to ETSI EN 302 636-6-1 V0.1.2 (2012-11). pages 6, 7, 8
- [ISO-21217-CALM-Arch] ISO 21217:2010 Intelligent transport systems – Communications access for land mobiles (CALM) – Architecture, April 2010. pages 1
- [rfc4291] R. Hinden and S. Deering. IP Version 6 Addressing Architecture. RFC 4291 (Draft Standard), February 2006. Updated by RFCs 5952, 6052. pages 4

- [rfc4941] T. Narten, R. Draves, and S. Krishnan. Privacy Extensions for Stateless Address Autoconfiguration in IPv6. RFC 4941 (Draft Standard), September 2007. pages 5

## Authors' Address

1. **Manabu Tsukada**

INRIA Paris - Rocquencourt Domaine de Voluceau Rocquencourt - B.P. 105 78153  
Le Chesnay Cedex France  
*manabu.tsukada@inria.fr*

2. **Masatoshi Kakiuchi**

Nara Institute of Science and Technology (NAIST), 8916-5, Takayama-cho, Ikoma,  
Nara 630-0192, Japan  
*masato@itc.naist.jp*

3. **Thierry Ernst**

Mines ParisTech, 60, Boulevard Saint-Michel 75272 PARIS cedex 06, France  
*thierry.ernst@inria.fr*