



Numerical simulation for the MHD system in 2D using OpenCL

Michel Massaro, Philippe Helluy, Vincent Loechner

► To cite this version:

Michel Massaro, Philippe Helluy, Vincent Loechner. Numerical simulation for the MHD system in 2D using OpenCL. ESAIM: Proceedings, EDP Sciences, 2014, 45, pp.485-492. 10.1051/proc/201445050 . hal-00919751

HAL Id: hal-00919751

<https://hal.archives-ouvertes.fr/hal-00919751>

Submitted on 20 Dec 2013

HAL is a multi-disciplinary open access archive for the deposit and dissemination of scientific research documents, whether they are published or not. The documents may come from teaching and research institutions in France or abroad, or from public or private research centers.

L'archive ouverte pluridisciplinaire **HAL**, est destinée au dépôt et à la diffusion de documents scientifiques de niveau recherche, publiés ou non, émanant des établissements d'enseignement et de recherche français ou étrangers, des laboratoires publics ou privés.

NUMERICAL SIMULATION FOR THE MHD SYSTEM IN 2D USING OPENCL

MICHEL MASSARO¹, PHILIPPE HELLUY² AND VINCENT LOECHNER³

Abstract. In this work we compute the MHD equations with divergence cleaning on GPU. The method is based on the finite volume approach and Strang dimensional splitting. The simplicity of the approach makes it a good candidate for a GPU implementation with OpenCL. With adequate memory optimization access, we achieve very high speedups, compared to a classical sequential implementation.

Résumé. Dans ce travail, nous résolvons les équations de la MHD avec correction de divergence sur carte graphique. La méthode est basée sur les volumes finis et le splitting directionnel de Strang. La simplicité de l'algorithme en fait un bon candidat pour la programmation sur carte graphique sous OpenCL. Avec de bonnes optimisations des accès mémoire, nous obtenons de très bonnes accélérations, comparé à une programmation séquentielle classique.

INTRODUCTION

The aim of this work is to propose an efficient algorithm for solving the two-dimensional MHD equations. The Magneto-Hydro-Dynamics (MHD) system is a model to describe the behavior of conducting fluids inside a magnetic field. It is useful for instance for simulating the edge plasma in tokamak simulations or astrophysics plasmas. For one-dimensional computations, we can assume that the magnetic field in the x -direction is constant. In this case the divergence free condition on the magnetic field B , which reads $\nabla \cdot B = 0$, is automatically satisfied. In higher dimensions, it is important to impose the divergence free condition in order to ensure a good precision of the scheme for long time simulations. We impose the condition through a divergence cleaning technique described in [3, 5].

Our numerical method is based on a the finite volume approach. We have implemented two different fluxes for solving the problem: the Rusavov flux, the VFRoe flux [2].

One objective of our work is to compute plasma reconnection in astrophysics. Such computations require very fine meshes and thus lead to long computations. Therefore, we have implemented our algorithm on GPU using the OpenCL environment. We use several techniques in order to achieve very high memory bandwidth: optimized transposition algorithm, cache prefetch, *etc.* We test our algorithms on one-dimensional and two-dimensional well-known test cases: a Riemann problem with a strong shock and the Orzag-Tang vortex.

¹ IRMA, 7 rue René Descartes, 67084 Strasbourg, michel.massaro@unistra.fr

² IRMA, 7 rue René Descartes, 67084 Strasbourg, helluy@unistra.fr

³ ICPS - LSIIT, Boulevard Sébastien Brant, 67400 Illkirch-Graffenstaden, loechner@icps.u-strasbg.fr

1. MODEL

The Magneto-Hydro-Dynamics (MHD) system a useful model for describing the behavior of astrophysical plasmas, or conducting fluids in a magnetic fields. The unknowns are the density ρ , the velocity $\mathbf{u} \in \mathbb{R}^3$, the internal energy e , the pressure p and the magnetic field $\mathbf{B} \in \mathbb{R}^3$. All of these unknowns depend on the time t and on the space variable $x \in \mathbb{R}^3$. For numerically enforcing the zero divergence condition on the magnetic field, it was proposed [6] to modify the original MHD equations by considering an additional variable ψ . With this "divergence cleaning" the equations read:

$$\partial_t \begin{pmatrix} \rho \\ \rho \mathbf{u} \\ E \\ \mathbf{B} \\ \psi \end{pmatrix} + \nabla \cdot \begin{pmatrix} \rho \mathbf{u} \\ \rho \mathbf{u} \otimes \mathbf{u} + (p + \frac{\mathbf{B} \cdot \mathbf{B}}{2}) \mathbf{I} - \mathbf{B} \otimes \mathbf{B} \\ (E + p + \frac{\mathbf{B} \cdot \mathbf{B}}{2}) \mathbf{u} - (\mathbf{B} \cdot \mathbf{u}) \mathbf{B} \\ \mathbf{u} \otimes \mathbf{B} - \mathbf{B} \otimes \mathbf{u} - \psi \mathbf{I} \\ c_h^2 \mathbf{B} \end{pmatrix} = 0, \quad (1)$$

$$E = \rho e + \frac{\rho \mathbf{u} \cdot \mathbf{u}}{2} + \frac{\mathbf{B} \cdot \mathbf{B}}{2}. \quad (2)$$

$$p = P(\rho, e) = (\gamma - 1)\rho e, \quad \gamma > 1. \quad (3)$$

$$\nabla \cdot \mathbf{B} = 0 \quad (4)$$

This system is a little bit different from the classical MHD system. It contains an additional variable ψ and a constant parameter c_h in order to impose the condition $\nabla \cdot \mathbf{B} = 0$ numerically. The parameter c_h must be an upper bound of the characteristic velocities of the system.

For all vector $\mathbf{n} = (n_1, n_2, n_3)^T \in \mathbb{R}^3$ and $\mathbf{W} = (\rho, \rho \mathbf{u}^T, E, \mathbf{B}^T, \psi)^T$ the vector of conservatives variables, we define the flux

$$\mathcal{F}(\mathbf{W}, \mathbf{n}) = \begin{pmatrix} \rho \mathbf{u} \cdot \mathbf{n} \\ \rho(\mathbf{u} \cdot \mathbf{n}) \mathbf{u} + (p + \frac{\mathbf{B} \cdot \mathbf{B}}{2}) \mathbf{n} - (\mathbf{B} \cdot \mathbf{n}) \mathbf{B} \\ (E + p + \frac{\mathbf{B} \cdot \mathbf{B}}{2}) \mathbf{u} \cdot \mathbf{n} - (\mathbf{B} \cdot \mathbf{u})(\mathbf{B} \cdot \mathbf{n}) \\ (\mathbf{u} \cdot \mathbf{n}) \mathbf{B} - (\mathbf{B} \cdot \mathbf{n}) \mathbf{u} + \psi \mathbf{n} \\ c_h^2 \mathbf{B} \cdot \mathbf{n} \end{pmatrix}. \quad (5)$$

The system is hyperbolic and the eigenvalues can be computed explicitly. We note a the speed of sound, c_A the Alfven's velocity, c_f and c_s the fast and slow magneto-acoustic velocity and λ_i the eigenvectors sorted in ascending order.

$$\begin{aligned} b &= \mathbf{B} \cdot \mathbf{n} \\ c_A &= \frac{b}{\sqrt{\rho}}, \\ a &= \sqrt{\frac{\gamma p}{\rho}}, \\ c_{f,s} &= \sqrt{\frac{1}{2} \left(\frac{b^2 + B^2}{\rho} + a^2 \right) \pm \sqrt{\frac{1}{4} \left(\frac{b^2 + B^2}{\rho} + a^2 \right)^2 - \frac{a^2 b^2}{\rho}}}, \\ \lambda_1 &= -c_h \\ \lambda_2 &= \mathbf{u} \cdot \mathbf{n} - c_f \quad \lambda_3 = \mathbf{u} \cdot \mathbf{n} - c_A \quad \lambda_4 = \mathbf{u} \cdot \mathbf{n} - c_s \\ \lambda_5 &= \mathbf{u} \cdot \mathbf{n} \\ \lambda_6 &= \mathbf{u} \cdot \mathbf{n} + c_s \quad \lambda_7 = \mathbf{u} \cdot \mathbf{n} + c_A \quad \lambda_8 = \mathbf{u} \cdot \mathbf{n} + c_f \\ \lambda_9 &= c_h \end{aligned} \quad (6)$$

2. FINITE VOLUME APPROXIMATION

2.1. Numerical scheme

In this work, we solve the two-dimensional MHD equations which read:

$$\partial_t \mathbf{W} + \partial_x \mathcal{F}(\mathbf{W}, \mathbf{n}_x) + \partial_y \mathcal{F}(\mathbf{W}, \mathbf{n}_y) = 0,$$

with $\mathbf{n}_x = (1, 0, 0)^T$ and $\mathbf{n}_y = (0, 1, 0)^T$.

We propose to use a dimensional Strang splitting. For advancing a time step Δt we first solve the 1D problem along x -direction

$$\begin{aligned} \partial_t \mathbf{V} + \partial_x \mathcal{F}(\mathbf{V}, \mathbf{n}_x) &= 0, \\ \mathbf{V}(t=0) &= \mathbf{W}_0, \end{aligned}$$

then along y -direction

$$\begin{aligned} \partial_t \mathbf{W} + \partial_y \mathcal{F}(\mathbf{W}, \mathbf{n}_y) &= 0, \\ \mathbf{W}(t=0) &= \mathbf{V}(t=\Delta t). \end{aligned}$$

For solving the one-dimensional problems, we use a finite volume scheme:

$$\mathbf{W}_i^{n+1} - \mathbf{W}_i^n + \frac{\Delta t}{h_i} (\mathcal{F}(\mathbf{W}_i^n, \mathbf{W}_{i+1}^n, \mathbf{n}) - \mathcal{F}(\mathbf{W}_{i-1}^n, \mathbf{W}_i^n, \mathbf{n})) = 0 \quad (7)$$

where \mathbf{W}_i^n is a constant approximation of \mathbf{W} on the cells $[x_{i-1/2}, x_{i+1/2}]$ at time t_n , and $h_i = x_{i+1/2} - x_{i-1/2}$ and where $\mathcal{F}(\mathbf{W}_i^n, \mathbf{W}_{i+1}^n, \mathbf{n})$ represents the numerical flux.

2.2. Numerical flux

The vector of primitive variables is defined by $\mathbf{Y} = (\rho, u_x, u_y, u_z, B_y, B_z, p)^T$. For smooth solutions, the one dimensional MHD system can also be written under the non conservative form

$$\partial_t \mathbf{Y} + \mathbf{A}(\mathbf{Y}, \mathbf{n}_x) \partial_x \mathbf{Y} = 0.$$

Let \mathbf{W}_L and \mathbf{W}_R be the left and right states at an interface between two cells. Let \mathbf{Y}_L and \mathbf{Y}_R be the left and right associated primitive variables. The VFRoe numerical flux [5] is given by

$$\mathcal{F}(\mathbf{W}_L, \mathbf{W}_R, \mathbf{n}) = \mathcal{F}(\mathcal{R}(\mathbf{Y}_R, \mathbf{Y}_L, 0, \mathbf{n})),$$

where $\mathcal{R}(\mathbf{Y}_L, \mathbf{Y}_R, \frac{x}{t}) = \mathbf{Y}(x, t)$ is the solution of the following linearized Riemann problem:

$$\begin{aligned} \partial_t \mathbf{Y} + \mathbf{A}(\bar{\mathbf{Y}}, \mathbf{n}) \partial_x \mathbf{Y} &= 0 \\ \mathbf{Y}(x, 0) &= \mathbf{Y}_L \text{ if } x < 0 \\ \mathbf{Y}(x, 0) &= \mathbf{Y}_R \text{ if } x > 0 \\ \bar{\mathbf{Y}} &= \frac{\mathbf{Y}_L + \mathbf{Y}_R}{2} \end{aligned}$$

The solution of the linearized Riemann problem is given by

$$\mathcal{R}(\mathbf{Y}_L, \mathbf{Y}_R, \frac{x}{t}) = \bar{\mathbf{Y}} - \frac{1}{2} \text{sgn}(A(\bar{\mathbf{Y}}) \cdot \mathbf{n} - \frac{x}{t} \mathbf{I})(\mathbf{Y}_R - \mathbf{Y}_L).$$

2.3. Entropy fix

The VFRoe flux has the advantage to be more accurate than other more diffusive fluxes such as the HLL or HLLC fluxes. One drawback is that it causes the apparition of non entropic shocks when the left and right eigenvalues (λ_L) and (λ_R) change of sign. To overcome this problem, we consider an entropy correction described in [2]. The previously defined numerical flux is replaced by

$$\mathcal{F}(\mathbf{W}_L, \mathbf{W}_R, \mathbf{n}) = \mathcal{F}(\mathcal{R}(\mathbf{Y}_R, \mathbf{Y}_L, 0, \mathbf{n})) - \frac{\min(|\lambda_L|, |\lambda_R|)(\mathbf{W}_R - \mathbf{W}_L)}{2}. \quad (8)$$

3. PROGRAMING ON GPU

3.1. Environment

In order to solve the MHD system, we need to compute 9 variables at each grid point. It is easy to see that in dimension 2 or 3, the number of operation is huge. For this reason, we decided to program the algorithm with OpenCL for running the code on graphic cards.

As opposed to a CPU which owns 2, 4, 8 or 16 cores, a Graphic Processing Unit (GPU) owns thousands of cores.

In the OpenCL abstraction, a typical GPU has several groups of computing units (CU) also called work-groups. Each work-group has several processing elements (PE) called work-items and its own fast-access cache memory. Each work-item in a given work-group can access to the cache memory of the work-group. In addition, the GPU has a slower-access global memory shared by all the work-items of all the work-groups. See Figure 1.

In our case, the GPU is managed by the CPU through the C library OpenCL.

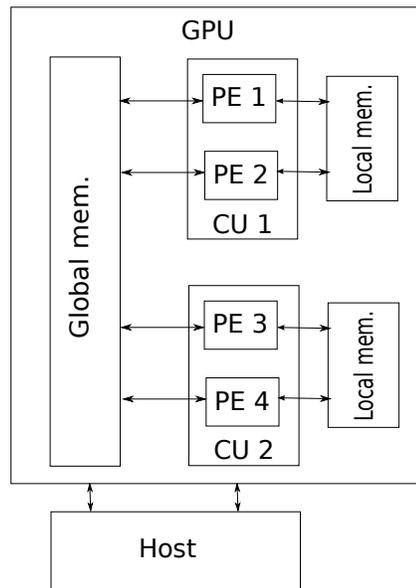

FIGURE 1. Architecture of a GPU

3.2. Programing strategy

In our algorithm, we associate to each work-item, the computation of one grid-point. The algorithm for one time step is made of the following stages

- (1) Computation of the finite volume algorithm along x .
- (2) Transposition of the grid data into the GPU memory.
- (3) Computation of the finite volume algorithm along y .
- (4) Transposition of data.

Because of the architecture of the GPU, managing the memory is the key point of the algorithm. Indeed, the transfer of data into the memory of the work-group is much faster if two successive work-items access successive memory locations. Such access are called coalescing access. Our data are initially organized in a two-dimensional array in x and then in y . When we compute the one-dimensional algorithm along x , the work-items access memory in a coalescing way and thus the memory bandwidth is optimal. With the same data organization we would perform the y memory access in a non-coalescing way. To improve efficiency, we thus apply an efficient transposition algorithm [8] between the x and y steps.

4. RESULT

4.1. Result in 1D

On Figure 2, we present the profile of the density at time $t = 1$ with a strong shock test case (see Table 1 for the initial conditions). Computation is done on 2048 grid points. We can see that the VFRoe scheme is really more accurate than the Rusanov scheme. We also verify the importance of the entropy fix. We clearly observe the appearance of a wrong shock when the flux is not corrected.

Variables	Left states	Right states
ρ	3	1
p	3	1
u_x	1.3	1.3
u_y	0	0
u_z	0	0
B_x	1.5	1.5
B_y	1	$\cos(1.5)$
B_z	1	$\sin(1.5)$

TABLE 1. Initials states for the strong schock test case

4.2. Result in 2D

The Orzag-Tang Vortex is a well-known test case for MHD codes. The results of this two-dimensional test case are given at time $t = 1$ and $t = 3$ on Figures 3 and 4. The computation is done on a 4096×4096 grid points with the Rusanov flux. The domain is $[0, 2\pi] \times [0, 2\pi]$ and the boundaries conditions are periodic in x and y . The initial conditions are given in Table 2.

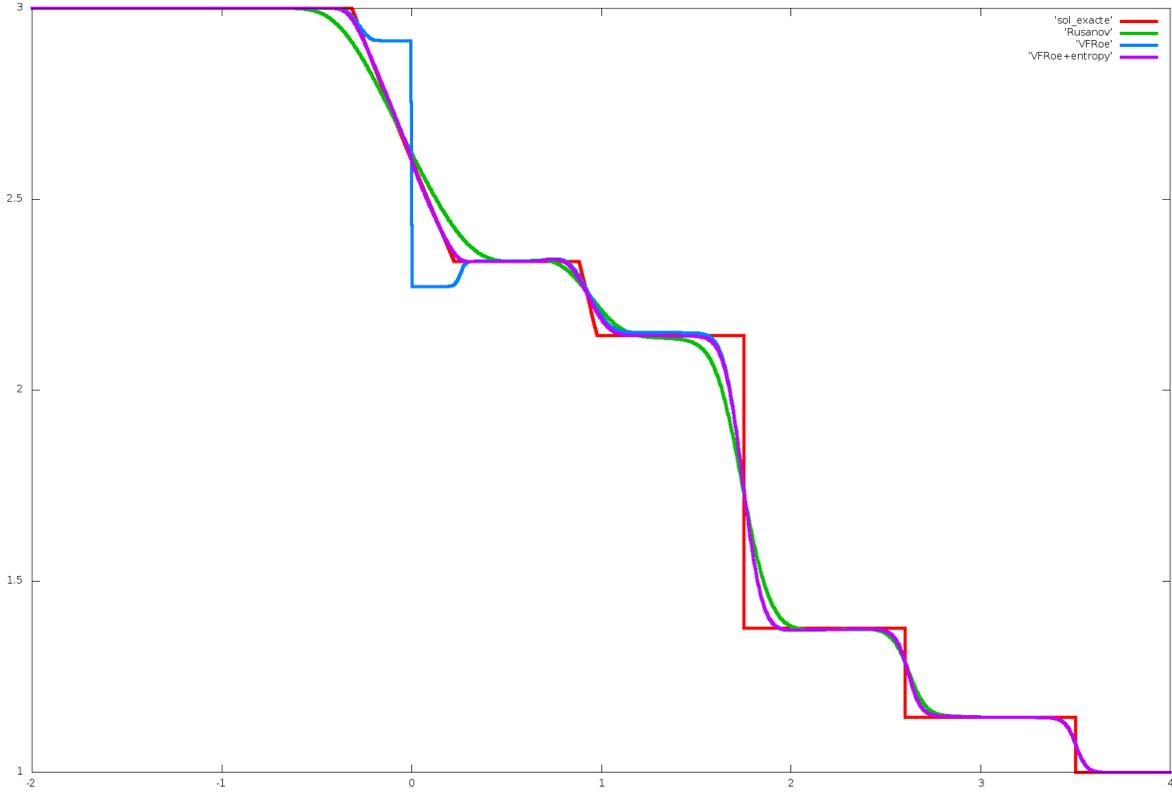

FIGURE 2. Comparison of the numerical fluxes with a one-dimensional Riemann problem. Red: exact, Green: Rusanov, Blue: VFRoe, Purple: VFRoe+entropy fix.

Variables	States
γ	$5/3$
ρ	γ^2
p	γ
u_x	$-\sin(y)$
u_y	$\sin(x)$
u_z	0
B_x	$-\sin(y)$
B_y	$\sin(2x)$
B_z	0

TABLE 2. Initial states for the strong shock test case

4.3. Speedup

OpenCL is a generic tool for programming GPUs or multicore CPUs. It is thus possible to compare the same algorithm running on these two architectures or on single core of one CPU. The results are given in Table 3.

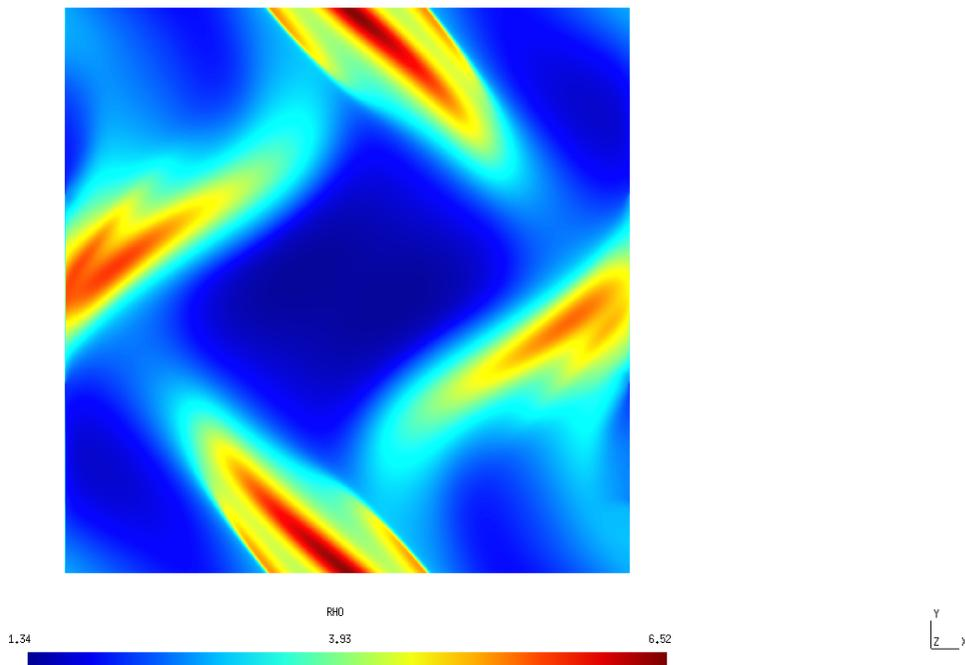

FIGURE 3. Density at time $T=1$, obtained with the Rusanov flux on a 4096×4096 grid for the Orszag-Tang’s test case [7]

	Time	Speedup
Intel Xeon 2,3GHz (1 thread)	9.6 days	1
Intel Xeon 2,3GHz (24 threads)	18.8 hours	12
AMD Radeon HD 7970	2.4 hours	93

TABLE 3. Computation times and speedups obtained on different architectures

5. CONCLUSION

We have proposed an efficient algorithm, based on directional splitting, for solving the two-dimensional MHD equations. The resulting algorithm is very well adapted to GPU architecture, because it allows optimal bandwidth memory access. We have implemented the method in OpenCL. On the Orszag-Tang vortex case, with a rather fine mesh, we have obtained very interesting speedups compared to the sequential algorithm.

REFERENCES

[1] F. BOUCHUT, C. KLINGENBERG, K. WAAGEN, *A multiwave approximate Riemann solver for ideal MHD based on relaxation II*, Numer. Math., 115(4):647–679, 2010.
 [2] P. HELLUY, J.-M. HÉRARD, H. MATHIS, S. MÜLLER, *A simple parameter-free entropy correction for Approximate Riemann solver*, Comptes rendues mécanique ISSN 1631-0721, vol 338, no. 9, 493-498, 2010.
 [3] C. ALTMANN, T. BELAT, M. GUTNIC, P. HELLUY, H. MATHIS, E. SONNENDRÜCKER, W. ANGULO, J.-M. HÉRARD, *A local time-stepping discontinuous Galerkin Algorithm for the MHD system*, ESAIM: Proc.28 33-54, 2009.

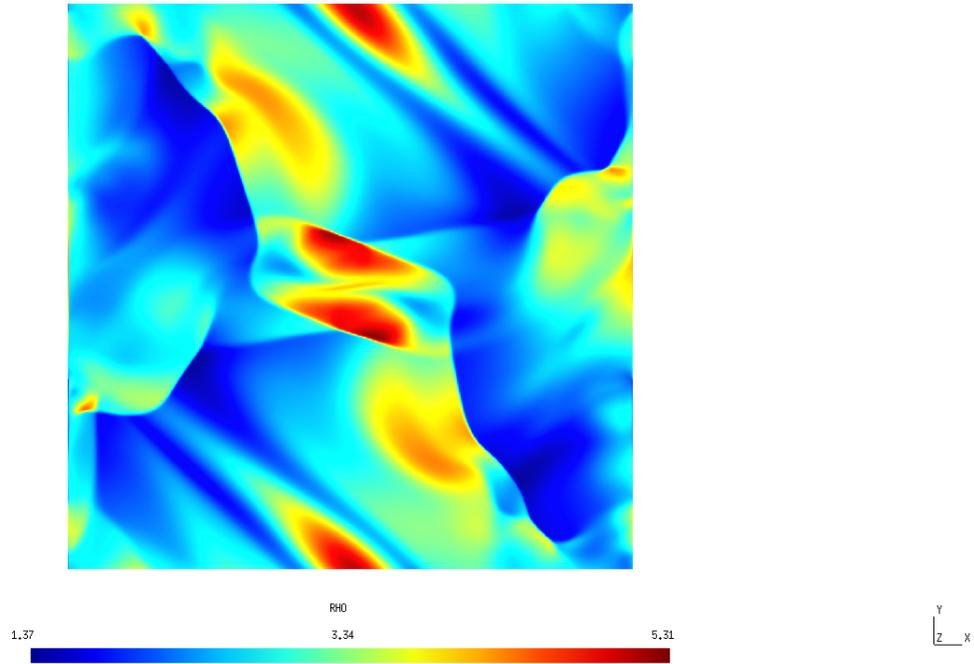

FIGURE 4. Density at time $T=3$, obtained with the Rusanov flux on a 4096×4096 grid for the Orzag-Tang's test case [7]

- [4] P. HELLUY, J. JUNG, *OpenCL numerical simulations of two-fluid compressible flows with a 2D random choice method*, IJFV International Journal on Finite Volumes, 10:1-38, 2013.
- [5] J.-M. MASELLA, I. FAILLE, T. GALLOUËT, *On an approximate Godunov scheme.*, Int. J. Comput. Fluid Dyn. 12, no. 2, 133-149, 1999
- [6] A. DEDNER, F. KEMM, D. KROENER, C.-D. MUNZ, T. SCHNITZER AND M. WESENBERG *Hyperbolic divergence cleaning for the MHD equations. J. Comput. Phys.*, 175(2):645-673, 2002
- [7] A. ORZAG, C.-M. TANG, *Small-scale structure of two-dimensional magnetohydrodynamic turbulence*, J. Fluid Mech, vol 90, 129-143, 1979.
- [8] G. RUETSCH, P. MICKEVICIUS, *Optimizing matrix transpose in Cuda*, NVidia GPU Computing SDK, 1-24, 2009.