

Purdue University

Purdue e-Pubs

Historical Documents of the Purdue
Cooperative Extension Service

Department of Agricultural Communication

11-1-1966

Selecting A Grain Drying Method

Bruce A. McKenzie

Follow this and additional works at: <https://docs.lib.purdue.edu/agext>

McKenzie, Bruce A., "Selecting A Grain Drying Method" (1966). *Historical Documents of the Purdue Cooperative Extension Service*. Paper 43.

<https://docs.lib.purdue.edu/agext/43>

For current publications, please contact the Education Store: <https://mdc.itap.purdue.edu/>

This document is provided for historical reference purposes only and should not be considered to be a practical reference or to contain information reflective of current understanding. For additional information, please contact the Department of Agricultural Communication at Purdue University, College of Agriculture: <http://www.ag.purdue.edu/agcomm>

This document has been made available through Purdue e-Pubs, a service of the Purdue University Libraries. Please contact epubs@purdue.edu for additional information.

SELECTING A GRAIN DRYING METHOD

COOPERATIVE EXTENSION SERVICE
PURDUE UNIVERSITY
LAFAYETTE, INDIANA

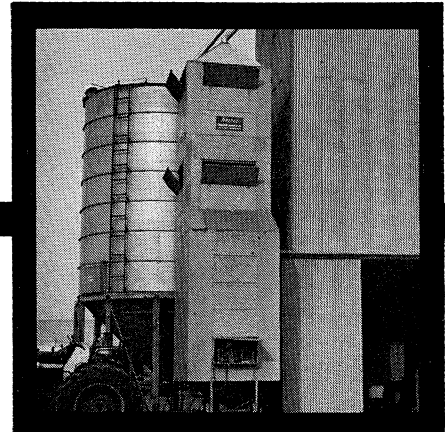
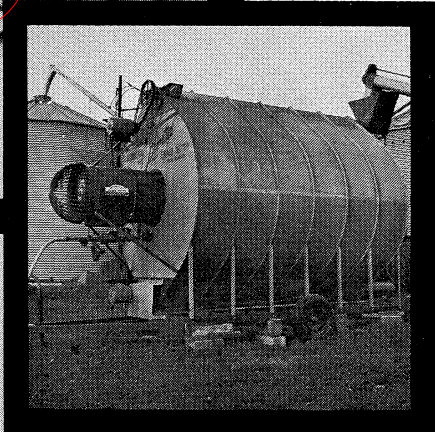

SELECTING A GRAIN DRYING METHOD

by

Bruce A. McKenzie

Extension Agricultural Engineer

The three basic methods available today for drying grain on the farm didn't just "happen along." There are sound engineering and economic reasons for layer, batch and continuous flow drying methods. No one of these drying methods is superior to all others considering the entire range of circumstances in the Corn Belt. Each has its place, and it is to your advantage as a farm operator to understand how each method works and how it fits the circumstances on your farm. A brief description of each of the drying methods and how they work should help you select a grain drying method.

Drying Methods

In-Storage Layer Drying. This method is exactly what the name implies—grain is dried in layers in place in the storage structure. Each layer is partially dried before the next is added. The rate at which the structure can be filled depends on the moisture content of the grain, the drying unit capacity and the operating procedure. The entire depth of grain is ultimately dried in place.

Batch Drying. There are two forms of batch dryers which are called column batch and batch-in-bin. In column batch the grain stands in a vertical column, usually 12 to 24 inches thick. In batch-in-bin the grain is spread over a perforated floor and dried in a shallow layer, usually 2 to 4 feet deep.

Both batch drying methods involve placing a quantity of grain in the dryer, drying and cooling it and then removing it to a separate storage structure. In the case of batch-in-bin, the drying bin is finally filled in layers and dried in place after other storage structures are full.

Continuous Flow. Again, this process is just what the name implies—grain flows continuously through the dryer. It enters wet at the top and is discharged dry and cool at the lower section. An adjustable grain flow device on the output regulates the rate of flow according to the amount of moisture removal required.

Characteristics of Drying Methods

Drying methods are frequently compared in terms of drying temperature, air flow, labor requirements, handling, initial cost, operating cost,

management, feed and market value of dried grain, and drying capacity. The two most important factors or characteristics for comparing alternative drying methods are the **drying capacity**, and the **investment necessary to get that capacity**.

To concentrate on these two characteristics passes over a number of factors that many people consider as determining the drying method. However, these factors will not generally force the decision. The differences will be so small that they will be of no real consequence. Or the factor cannot be meaningfully measured or evaluated with current information and depends on personal preference. Special product requirements, such as seed drying, may cause a different rating.

Fuel and power. Assuming fuel and power costs and drying temperature as nonforcing factors is probably the most difficult idea to accept. Speed costs money whether in cars, tractors, rockets or grain dryers. The higher speed methods of drying will usually be some less efficient in the use of fuel and power. But this loss in efficiency when weighed against the **total** efficiency of a large volume corn harvesting operation is of little consequence. A large operator might choose a deep layer drying method, but have a drying capacity that will continually delay harvest. He simply cannot get enough air and heat energy through the deep layer of grain to get an economical drying speed. To invest in sufficient deep layer units to get the capacity will run investment cost in drying equipment out of line. Efficiency must obviously consider more than just dryer operating cost.

Air Flow. Much discussion is frequently centered around the air delivery of a particular drying fan. This has been especially true in discussing bin drying methods. Actually, most agricultural drying fans today are good quality. The difference in air flow per horsepower between two units of comparable size and type will generally be very small. On this basis air flow efficiency will not generally force the decision.

There are, however, some industry rating practices that are confusing. Fan motors, for instance, frequently deliver more horsepower than their nameplate rating, or the nameplate carries a dual rating indicating a range of horsepower.

These practices make it seem that a given "five horsepower" fan delivers more air than the competitor's. The fact is that the fan probably delivers more air flow because the fan motor delivers more horsepower. The air flow per horsepower will be essentially like any other comparable fan-motor combination.

Heat Input. Assuming air flow is adequate for the drying method involved, drying systems normally fail, not on the basis of air flow, but rather on heat and management. System failure due to heat can come from too little or too much. Correct management is important. Inadequate heat slows drying capacity; excessive heat damages quality. There are desirable and workable air-heat ratios for each drying method, and they vary between methods. There is currently a tendency in the trade to overrate the burner output of bin drying units. The use of higher drying temperatures, as in batch-in-bin drying methods, has forced increased burner input. But actual burner delivery on a wide range of farm circumstances has not always kept pace with the burner output ratings listed. Or, burner rating may be correct but exceed the gas yield of a typical farm LP gas tank installation.

Liquid petroleum gas tanks (LP Gas) can be rigged to either draw vapor from the top of the tank, or liquid from the bottom. Agricultural drying burners are available for both fuel forms. But a 1,000 gallon LP Gas tank will generally not yield sufficient vapor to supply 1,000,000 BTU/hr. at outside temperatures below 30° to 40° F. Yet many burners are currently rated in the 1.5 to 4 million BTU range for vapor withdrawal.

One solution is to connect several tanks in parallel, drawing vapor from all tanks simultaneously. There are also gas vaporizers available. Typical units look like a 30 gallon water heater and burn a small quantity of gas to heat the solution to increase vaporization rate. They are free standing and are installed between the tank and the burner. Finally, some burners can be equipped with a vaporizer.

You should recognize that the presence of liquid in the burner presents some added hazard over the presence of vapor. This is because the liquid expands over 250:1 when released, whereas the vapor has already expanded. Hence, a small leak involving liquid liberates a much greater quantity of vapor than the same leak liberating vapor directly. This is to suggest that if you do not need the higher burner output requiring liquid with-

drawal, consider a vapor withdrawal unit. But recognize that many crop dryers have used liquid withdrawal successfully for many years.

Drying temperature. Drying temperature has received much discussion. The heat damage in corn that the wet millers are concerned about is apparently a time-temperature relationship. It is how much heat (temperature) for how long, which is actually the **total heat applied**. The longer the heat is applied the more likely is damage to occur at critical limits. Consequently, corn at 30 percent is more likely to be damaged than 20 percent at the same drying temperature.

Research generally indicates that there is no significant change in feed value of grain dried at kernel temperature up to 180°. Grain dried for the wet milling trade (milled for corn starch, gluten, oil, by solvent processes) is generally limited to 140° kernel temperatures. Air temperatures may be considerably in excess of kernel temperatures if the kernel is not exposed long enough to reach air temperature or pass critical limits. High drying temperature does not categorically brand a given drying method or dryer as "damaging grain." All of the present commercial drying methods will produce quality corn with correct management. Drying temperature will not alone force the choice of drying method except in very special cases.

A joint USDA-Purdue research project currently underway is studying the effect of drying temperature on corn quality. It has uncovered several interesting facts. First, the stress cracks associated with heated air dried corn occur in all drying methods. In fact, studies indicate that any time a kernel of corn is removed from the cob at moisture contents above 20 percent, the kernel will likely develop a stress crack. The studies also demonstrate that cracking and breakage in corn is tied to drying speed—the faster the corn is dried, the more cracks that develop. Stress cracks contribute to breakage during handling, and to smaller and lower quality grits made in the dry milling process.

Laboratory studies of stress crack formation in this same USDA-Purdue project indicated that many of the cracks were formed during the final stages of drying and during the fast cooling period. The shattering might be analogous to heating a rock and then cooling by throwing water on it. A new process, called Dryeration, was developed using tempering and slow cooling to re-

duce shattering. The corn is removed from the drying chamber at some moisture content above finish condition and placed in a tempering-cooling bin. After tempering, the grain is cooled slowly, utilizing the stored heat in the corn to vaporize the remaining moisture to be removed. Quality is increased by reducing stress crack formation, and brittleness is also reduced. The capacity of high temperature dryers can be doubled if corn handling time is minimized. A 60 percent increase is easily attained with a good handling layout.

Handling and Labor Requirements. The alternative drying methods are obviously different in the amount of handling equipment, rehandling of grain, and labor-management involved. In-storage layer drying involves only two handling operations—in-to-storage at harvest and storage unloading at market. Batch and continuous flow processes involve an extra handling operation in-to and out-of the dryer, in addition to receiving and unloading.

The fact remains, however, that every farm has to have handling equipment, whether it is used on two or three operations per year. Furthermore, the larger the volume of grain to be handled, the less desirable is a totally portable handling system. As volume increases, the need becomes apparent for a stationary handling system tied in with a centralized drying process and storage layout. Sequenced operations must be ready to go, to minimize down time and keep the process flowing smoothly.

The higher capacity drying methods, involving batch or continuous flow processes, are generally associated with these large volume operations. The large receiving volume tends to require a high capacity, ready-to-go handling system. It also happens that this handling system is readily adaptable to batch or continuous flow drying processes. Thus, it is generally the large volume of material to be handled at a high rate that determines the handling equipment cost, not the choice of drying method.

It is important to note that the grain livestock farmer may carry a higher level of mechanization, particularly on storage unloading, than the cash grain operator. The livestock farmer unloads storages almost daily in making and distributing feed. Storage unloading equipment must be ready to go. Any significant time loss on the highly repetitive operation will accumulate fast throughout the year. In contrast, the cash grain farmer

probably unloads once per year. If he spent one-half day getting ready, this may be insignificant, assuming he unloads his entire crop.

Drying capacity. The capacity of the drying system should be one of the prime characteristics which you compare on alternative methods. Each of the methods will produce quality corn with the correct management. It is a question of whether the method offers a workable procedure for your operation. Daily drying capacity is one of the prime factors to consider in selecting a method.

Investment cost. The amount of money needed to get the desired drying capacity is the primary cost item to consider. Differences in fuel and power costs will usually not be great enough to force the decision either way. But with ownership costs running roughly half of the total cost of drying a bushel of grain, doubling the drying equipment investment sharply increases the total cost of drying. If you invest excessively in drying capacity, costs are bound to be high.

Performance Relationships

Having selected the drying method or methods that seem to fit your situation, you can then add the necessary handling and storage equipment in your estimate and gain a more complete view of how the unit might work and fit your farm.

Table 1 presents performance and drying cost relationships for the most common drying methods. Data are presented for in-bin layer drying in a five horsepower size; three sizes of batch-in-bin dryers; three sizes of batch dryers; and two sizes of continuous flow dryers.

It is important to note the difference in **air flow rate per bushel and drying temperature** for the different methods. Air flow ranges from 5 cfm/bu to 100 cfm/bu, 20 times difference. Temperatures range from 10-20° above outside air to 225°—about 10 times difference in 50° outside temperature. If you double the air flow and heat the air to the same temperature, you **double** the fuel input. Or, leave airflow constant and double the temperature, you double the heat input. Since it is basically the heat added that does the drying, particularly in the higher temperature units, you would expect capacity to increase. Increased temperatures may require a change in shape of the dryer to control kernel exposure time. All of these changes increase the cost of the dryer, and the question is whether the capacity is worth the cost.

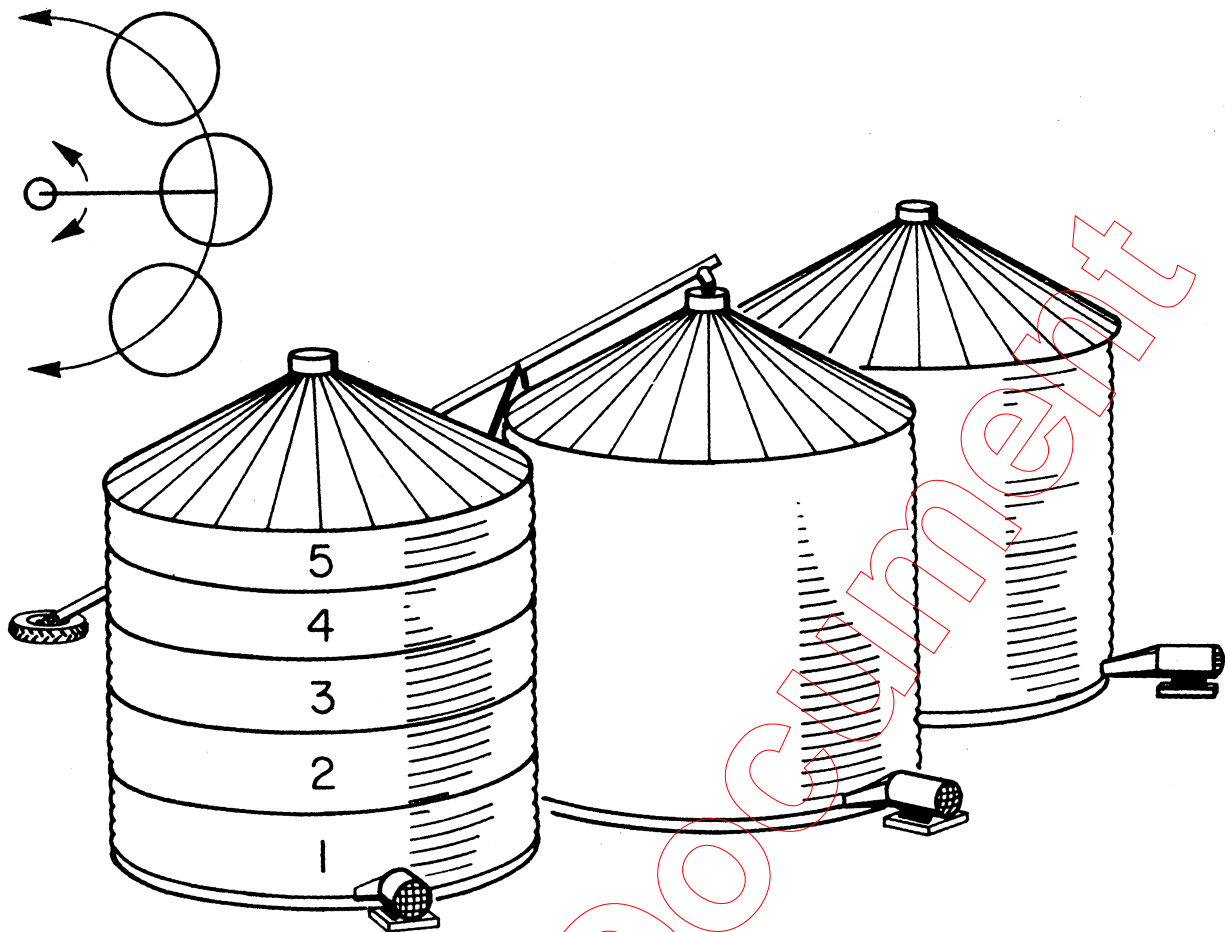

Figure 1. In-Bin Layer Drying with Supplemental Heat. Bins are filled in rotation, one layer at a time. As each layer partially dries, successive layers are added until storage is full and the grain is dried in place. Layer quantity depends on moisture content of grain and fan-heater output. Unit is set to deliver 10-15 degrees of heat, usually humidistat controlled.

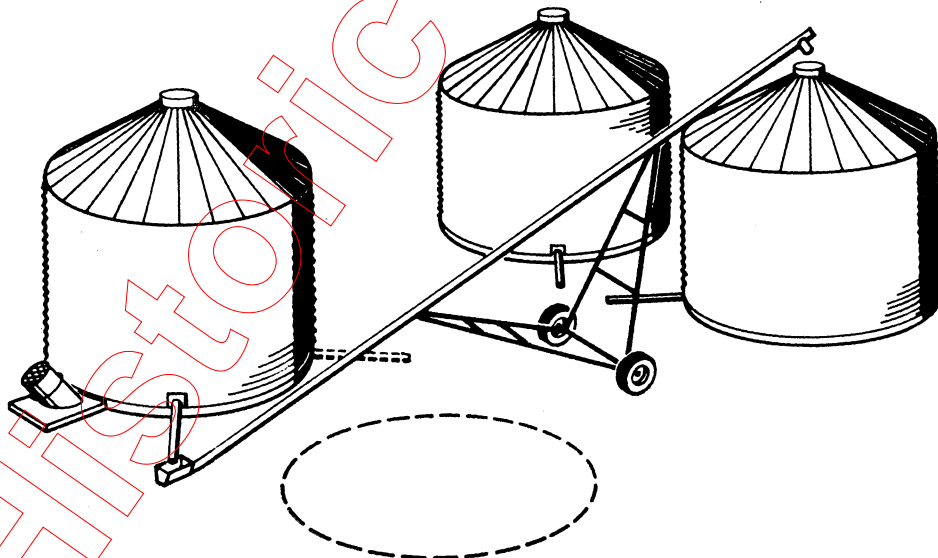

Figure 2. Batch-In Bin Drying. A shallow layer of grain, 2 to 4 feet deep, from one day's harvest is dried in 24 hours and transferred to storage. When storage bins are full the drying bin is filled in layers and dried. Drying temperature is normally 110-130 degrees F. No wet grain storage is needed since a batch is one day's harvest. The layout shown is planned so that a vertical elevator may be substituted in the future. A second unload tube (shown in dotted lines) would be installed in the drying bin to deliver grain to the vertical elevator located in the center area between the bin rows. The two rows of bins would be 24 feet apart to receive a future 20-foot wide center structure.

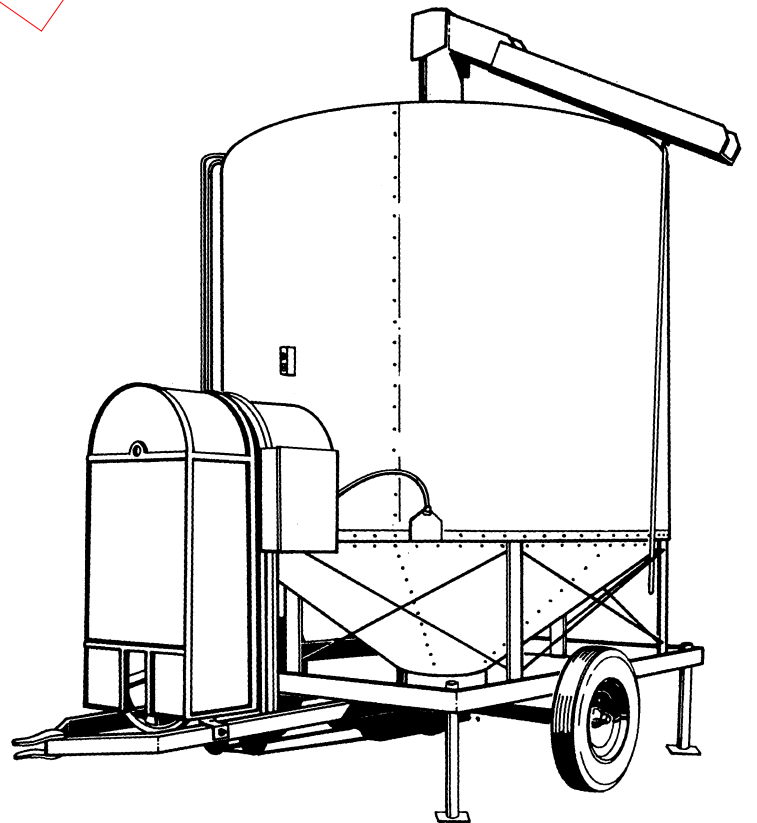
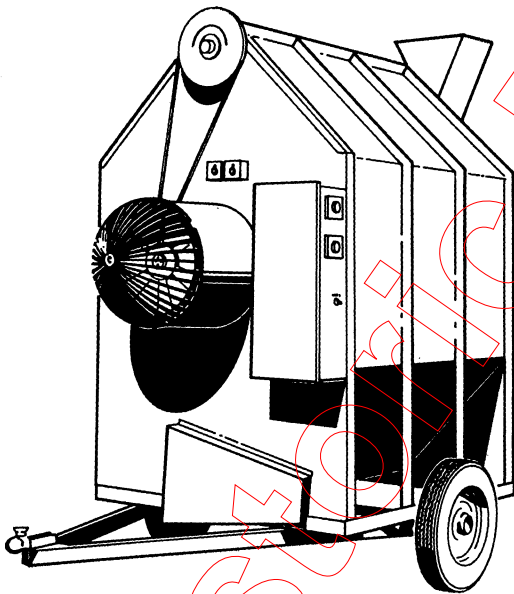
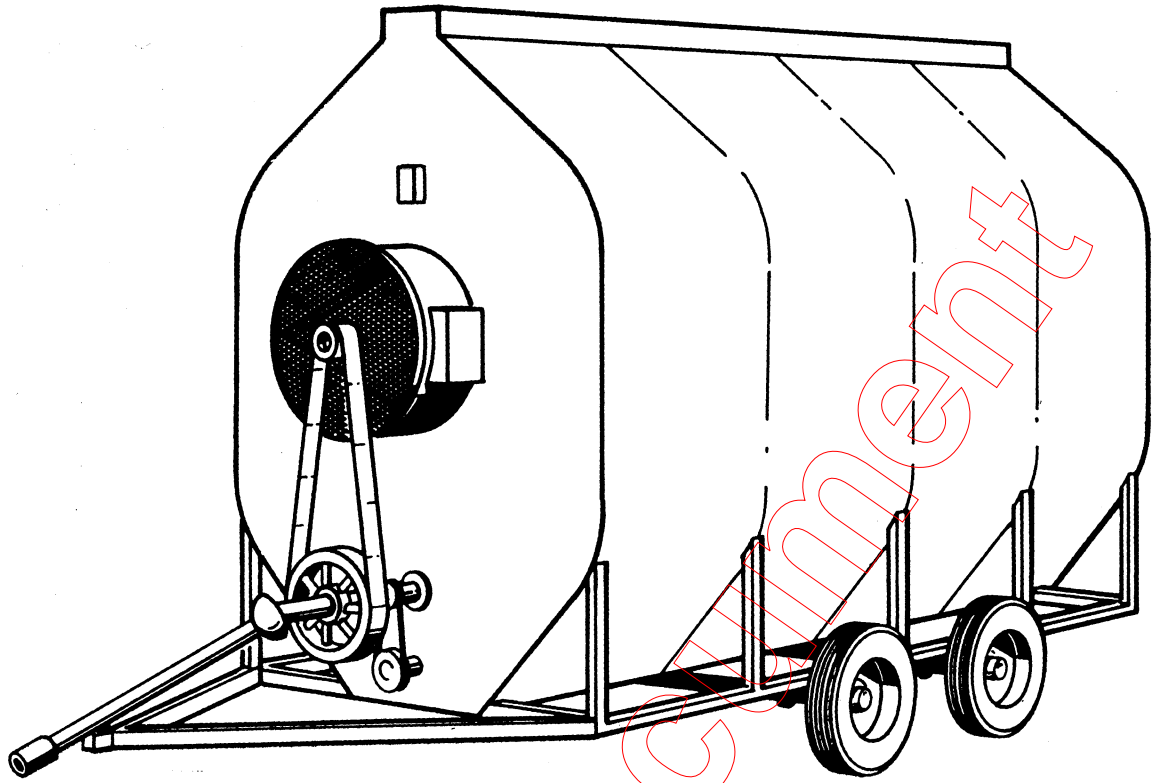

Figure 3. Batch Dryers. Batch units dry a fixed amount of grain, cool it and then unload. Self-loading and unloading is common and re-circulation of grain during the drying cycle is an optional feature on many units. Units are also available in fully automatic and semi-automatic cycle control, so the unit will perform unattended. Wet grain storage ahead of the dryer is very desirable.

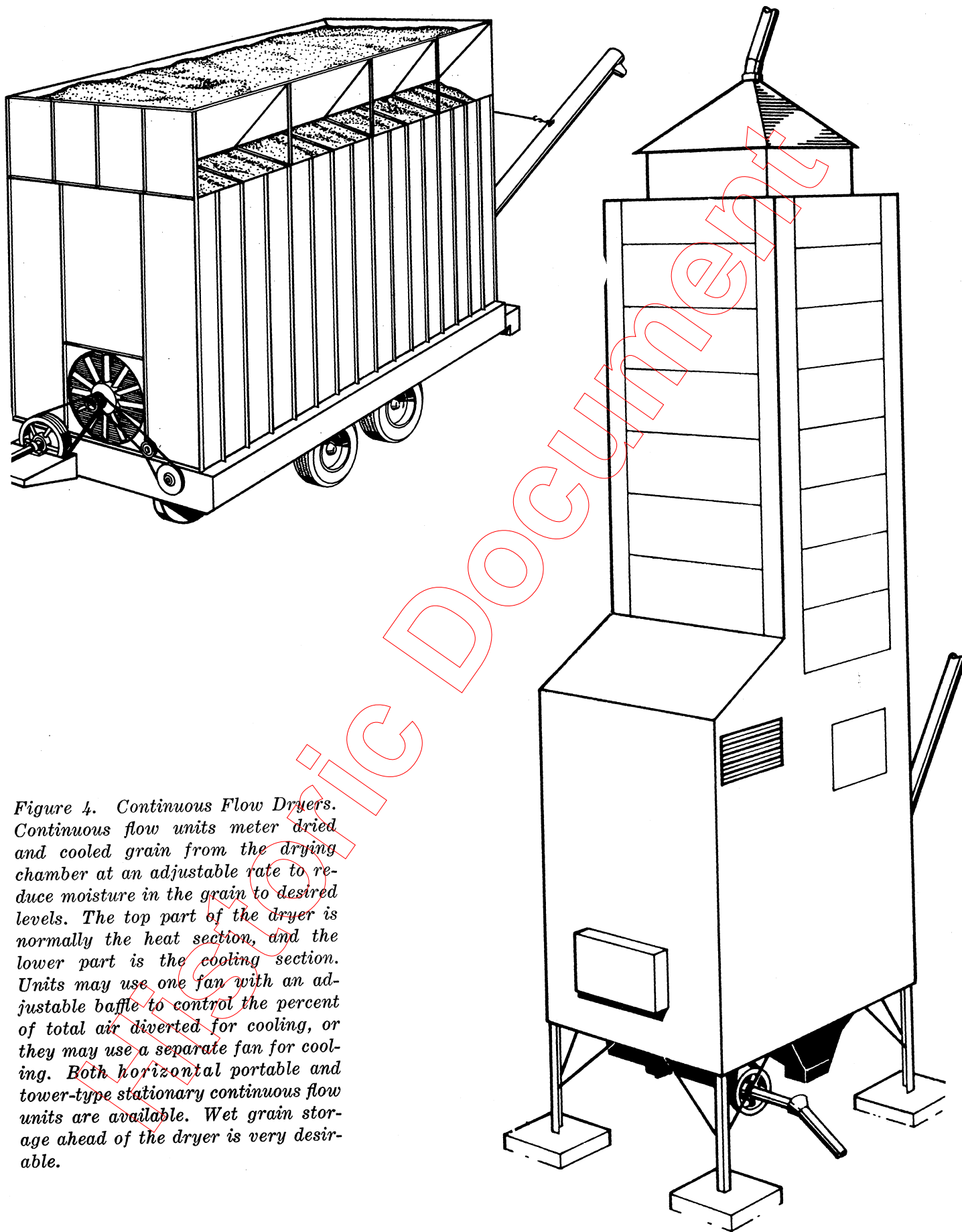

Figure 4. Continuous Flow Dryers. Continuous flow units meter dried and cooled grain from the drying chamber at an adjustable rate to reduce moisture in the grain to desired levels. The top part of the dryer is normally the heat section, and the lower part is the cooling section. Units may use one fan with an adjustable baffle to control the percent of total air diverted for cooling, or they may use a separate fan for cooling. Both horizontal portable and tower-type stationary continuous flow units are available. Wet grain storage ahead of the dryer is very desirable.

Table 1. Estimated cost and performance relationships of grain dryers on shelled corn drying from 25% to 13½% w.b.¹

ITEM	In-storage layer	Batch-in-bin			Portable batch dryers			Continuous flow dryers	
		Small	Medium	Large	Small	Medium	Large	Small	Medium
Dryer specifications, size	5,000 bu bin (21' dia)	5,000 bu bin (21' dia)	6,500-8,000 bu (24-27' dia) bin	10,000 bu bin (27-30' dia)	72 bu batch	250 bu batch	500-700 bu batch	250-400 bu	350-600 bu
Fan	5 hp fan	5 hp fan	7½ hp fan	10 hp fan	2-3 hp fan	10-15 hp fan	20-30 hp fan	20-30 hp fan	40-50 hp fan
Heater	3-600,000 btu	1,000,000 btu	1.5-2 mil btu	4.5 mil btu	2 mil btu	2-3 mil btu	4-5 mil btu	4-6 mil btu	5-7 mil btu
Approximate air flow	3-5 cfm/bu	10-15 cfm/bu	10-15 cfm/bu	12-25 cfm/bu	100+ cfm/bu	50-70 cfm/bu	50-70 cfm/bu	75-100 cfm/bu	75-100 cfm/bu
Approximate drying temperature	Add 20° heat to outside air	120°F (110°-140°)	120°F (110°-140°)	120°F (110°-140°)	140-200°F	140-180°F	140-180°F	140-225°F	140-225°F
Estimated drying capacity 25% to 13½% corn	300 bu/bin/day	800-1,000 bu/24 hr.	10-1,200 bu/24 hr.	12-1,600 bu/24 hr.	600-700 bu/16 hr.	1,000 bu/16 hr.	12-1,600 bu/16 hr.	125 bu/hr. or 2,000 bu/16 hr.	200 bu/hr. or 3,200 bu/16 hr.
Estimated investment cost Drying equipment only	\$1,000/bin	\$2,000/bin	\$2,500/bin	\$3,500/bin	\$1,500	\$3,000	\$4,000-5,500	\$5,500-6,500	\$8-10,000
Drying capacity vs investment Bushels per \$1,000	300 bu/\$1,000	400 bu/\$1,000	400 bu/\$1,000	400 bu/\$1,000	400 bu/\$1,000	300 bu/\$1,000	300 bu/\$1,000	300 bu/\$1,000	300 bu/\$1,000
Estimated annual fixed cost % new cost	12%	13%	13%	13%	15%	15%	15%	15%	15%
Estimated annual ownership cost Drying equipment only	\$120/unit, bin	\$260/unit, bin	\$325/unit	\$455/unit	\$225	\$450	\$675	\$900	\$1,350
Estimated variable cost/bu (25%-12½%)	2.5-4.0¢	2.5-4.0¢	2.5-4.0¢	2.5-4.0¢	2.5-4.0¢	2.5-4.0¢	2.5-4.0¢	2.5-4.0¢	2.5-4.0¢
Estimated ownership cost/bu ² / 5,000 bu	2.4¢ (1 unit)	5.2¢ (1 unit)	6.5¢ (1 unit)	9.1¢	4.5¢ (1 unit)	9.0¢	13.5¢	18.0¢	27.0¢
10,000 bu	2.4¢ (2 units)	2.6¢ (1 unit)	3.3¢ (1 unit)	4.6¢	2.25¢ (1 unit)	4.5¢	6.75¢	9.0¢	13.5¢
15,000 bu	2.4¢ (3 units)	1.7¢ (1 unit)	2.2¢ (1 unit)	3.0¢	1.5¢ (1 unit)	3.0¢	4.5¢	6.0¢	9.0¢
25,000 bu	2.4¢ (5 units)	2.1¢ (2 units)	2.6¢ (2 units)	1.8¢	1.8¢ (2 units)	3.6¢ (2 units)	2.7¢	3.6¢	5.4¢
50,000 bu	2.4¢ (10 units)	1.6¢ (3 units)	2.0¢ (3 units)	1.8¢ (2 units)	1.35¢ (3 units)	1.8¢ (2 units)	1.35¢	1.8¢	2.7¢

¹ Data are based on equipment currently available. Some specifications exceed the minimum requirements for the capacity shown. An alternate drying procedure might utilize this reserve capacity.

² The ownership cost/bu values are not directly comparable unless drying capacity is also considered. The lowest cost/bu for a given method and volume may also give reduced capacity. Multiple units indicated are based on arbitrary capacity requirements for that volume.

The key comparison is the capacity-cost ratio in Table 1. It is interesting to note that all methods are reasonably constant on this basis. This says that it costs about so much to evaporate a pound of water, and it doesn't make too much difference how you do it in grain dryers, assuming all are sound designs. This suggests the volume of corn to be dried is the critical factor.

You should observe that some drying methods require adding units to get additional capacity. If the investment is increased enough times, the ownership costs of several smaller units may equal that of a single unit of higher first cost. Three 5 hp layer drying units, for instance, would be required to obtain 900 bu per day drying

capacity. At a drying equipment cost of \$1,000 per bin, investment would be \$3,000. This output-cost ratio equals that of a medium size batch dryer. This suggests that a break-even concept should be applicable to choose between methods.

The drying methods are presented graphically in Figure 5 in relation to the volume of grain on which each might be expected to fit. The volume limits of a given method are not by any means absolutely fixed, but are rather suggested ranges for the drying method. The range indicated is a judgment of the author based on a combination of fixed costs, handling equipment, and operation and management considerations.

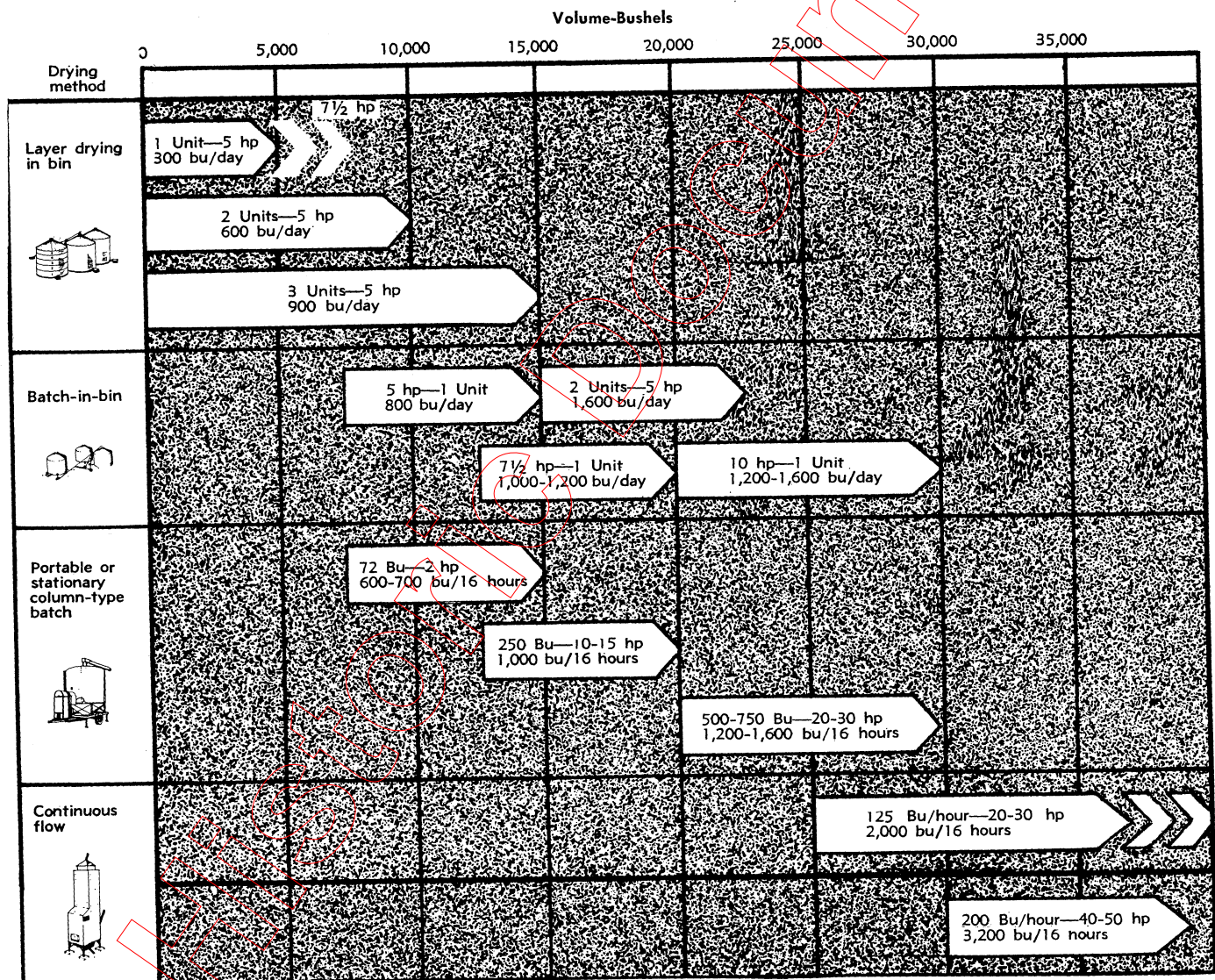

Figure 5. Suggested volume ranges for alternative drying methods based primarily on drying capacity and management considerations. Drying units listed here correspond to specifications in Table 1. Methods overlapping specific volume ranges are not necessarily of equal fixed cost. Fixed costs can be estimated from Table 1. This graph visualizes the main points brought out in Table 1. The volume ranges have been selected so that two methods can overlap in part of the volume range. This has been done on a judgment basis to compensate for the fact that one method of drying may require a more complex handling system for its best performance.

Choosing the Drying Method

The data in Table 1 and the bar graphs in Figure 5 should help bring the alternative drying methods into clearer perspective. Several other considerations should help narrow the choice of drying method for your farm.

Weather. Agricultural climatologists suggest that the Corn Belt farmer has approximately 22 operating days out of the 6 weeks "Indian Summer" period, in which to harvest his crop. The 22 days is determined by subtracting Sundays, plus the number of days with 1/10" or more rainfall that would occur 9 out of 10 years. A day of 1/10" or more rainfall has been judged to prevent field operation; subtracting such days occurring 9 out of 10 years gives a 90 percent chance of realizing the remaining days. Hence, 9 out of 10 years you can expect at least 22 operating days.

The 22 operating days will be further reduced on some farms by 1) soybean harvesting; 2) livestock tending time; and 3) machine breakdown.

Ideally, harvest and drying rate would be based on the 22 available harvest days. Assuming a 22,000 bushel crop, a daily harvest-drying rate of 1,000 bushels might be adequate. Actually, basing the design on 15 days at 1,500 bushels per day for a 22,500 bushel season capacity may be more realistic for many farms.

The large farm probably cannot afford to hold harvest just to the Indian Summer period. It would seem that the cost of increased harvest-drying capacity should be weighed against the cumulative value of increased field loss of the extended harvest.

Drying methods. There are some differences in drying methods that have not been discussed before that have some bearing on the final decision. For instance, the layer drying process has a very strict limitation on the amount of heat that can be used. The method is basically a low cost, go slow approach. The amount of heat used must not over dry the lower layers of grain before the top layers are dried. You cannot simply turn up the heat to go faster because this may seriously overdry the lower layers.

The amount of corn that can be placed on a layer dryer is determined by the amount that can be dried before molds develop. The mold growth is a function of the grain moisture and temperature.

Thus, the operator must follow the rules laid down by the manufacturer **very explicitly**. He has a system with a very low reserve capacity. He

should not use more heat because this will unbalance the system.

Contrary to what is frequently stated about layer drying, it is the author's judgment that it requires superior management. The equipment system is simple. But the necessity for knowledge of the drying process is increased to compensate for the fact that extra horsepower and energy cannot be used to get out of trouble.

The length of the drying period in layer drying normally eliminates the chance of drying two bins full in the same harvest season with the same equipment. Thus, the operator has only one learning experience per bin per year. Experiences learned have to be carried forward to next year. This means that correct procedures and management as the corn goes into the bin are essential.

Batch processes, in contrast, offer an opportunity to correct mistakes at the end of every batch. The longest cycle time would normally be 24 hours on batch-in-bin and much shorter on conventional batch. This gives the operator a learning experience with quick, daily results to judge the wisdom of his procedure. He should be able to determine a procedure that will produce quality corn.

Both the batch and the continuous flow process have the disadvantage that all corn must be handled at least twice—once through the dryer and then to storage. The point was made earlier that the mechanization desirable to do this is probably needed for the volumes of corn adapted to batch and continuous flow drying. But the fact remains that neither method will work well without a well coordinated handling arrangement.

Both the portable batch dryer and continuous flow units also require wet grain storage ahead of the dryer for the best performance. The minimum wet grain storage would usually be at least 1½ times the batch size, or 1½ times the largest hauling vehicle, whichever is larger. Thus, the holding bin does not have to be exactly full or empty before it can be filled or unloaded into the dryer. Most farmers like a wet grain storage that holds at least two batches. This will let the dryer run for an extended period of time after nightfall or a harvest breakdown.

Wet grain storage on wheels is usually not very satisfactory unless it is a special design holding at least one batch. On specially designed vehicles the running gear is only made to carry the bin when it is empty so it can be moved to a new dry location. Wet grain bins may be adapted from

bulk feed tanks, round metal bins, or built into existing crib or building sections.

Layer dryers and batch-in-bin units normally operate on a 24 hour cycle, day and night. Night time operation is unsupervised, with automatic heat and fan shut off when the grain is dry and cool now available for batch-in-bin units. Since the normal moisture removal rate is approximately $\frac{1}{2}$ percentage point per hour for batch-in-bin, a slight error in estimating dry time is not critical. In contrast, most batch and continuous flow process designs are based on a 16 hour day. This obviously involves some time in the late evening or night. This can get tiresome if you have also harvested and hauled corn all day, for 10-12 hours. Automatic controls and malfunction warning devices have made it possible to run both units for extended periods of time without supervision, including overnight operation. Good safety controls are a must for such operation.

A centralized drying facility, for both portable and stationary dryer designs, is generally desirable. The idea of drying with a portable unit in the field, or at numerous farmstead locations, usually fails because of the corn handling problem. Wet grain storage is difficult, and the number of portable conveyors necessary is a burden. The layouts are frequently characterized as full of "busy work."

A centralized grain handling and storage facility has several advantages on many farms. All handling is concentrated at one site permitting permanent installation of handling equipment. Drying also is centralized for easier observation. In drying methods involving re-handling of grain, wet grain-dryer-Dryeration-storage operations can be organized for "ready-to-go" handling practically and economically. Further, on livestock farms, feed processing can be added to the same facility, utilizing working bins and handling equipment. The central location, if at the main farmstead, gives efficient supervision of feed preparation.

Grain produced on remote farmsteads is frequently still hauled to the central site. Truck hauling 2-5 or more miles may be less trouble than operating the dryer at two locations with poor

handling organization. Some farmers even return-haul dry corn back to the production site as they return to the field.

Continuous flow dryers usually require handling both wet and dry corn at the same time. The handling equipment will frequently include a high capacity elevator for receiving wet corn and feeding the dryer, plus a small dry corn elevator. The use of two elevators can be avoided if surge bins are installed for wet corn ahead of the dryer and for dry corn on the output side. The transfer of dry corn to the storage is usually done on a manually supervised basis in the latter design.

It should not be inferred from the previous discussion of drying methods that layer drying will not work. Nothing could be further from the truth. There are thousands of layer drying units all over Indiana and the Corn Belt doing good jobs. If the equipment application is sound and the correct management is applied, the results can be excellent.

The problems with all dryers come about when the equipment is misrepresented, misapplied, misused or the management is not there. There has been too much of each of these, covering all brands and types of dryers.

Similarly, some of the disadvantages cited for other drying methods, such as night time operation of batch or continuous flow units, should not be overemphasized. There are many drying installations throughout Indiana and the Corn Belt that are doing excellent jobs. Some of these farmers were early shelled corn adopters and may be on their second or third drying unit, still choosing the same basic design.

So how do you know which one to choose? One of the best methods is to visit and talk with people who have a drying unit like the one you're considering. The only thing is, be sure you include some good designs for the method in question in your visits. No point in adding confusion. And, start early—this is a big decision and it takes time.

Your local Cooperative Extension Agent should be a good source for finding locations of good system designs.

Historic Document

10M 10/66

Cooperative Extension Work in Agriculture and Home Economics, State of Indiana, Purdue University and U. S. Department of Agriculture Cooperating. H. G. Diesslin, Director, Lafayette, Indiana. Issued in furtherance of the Acts of May 8 and June 30, 1914.